

AlphaServer 1000

Technical Summary

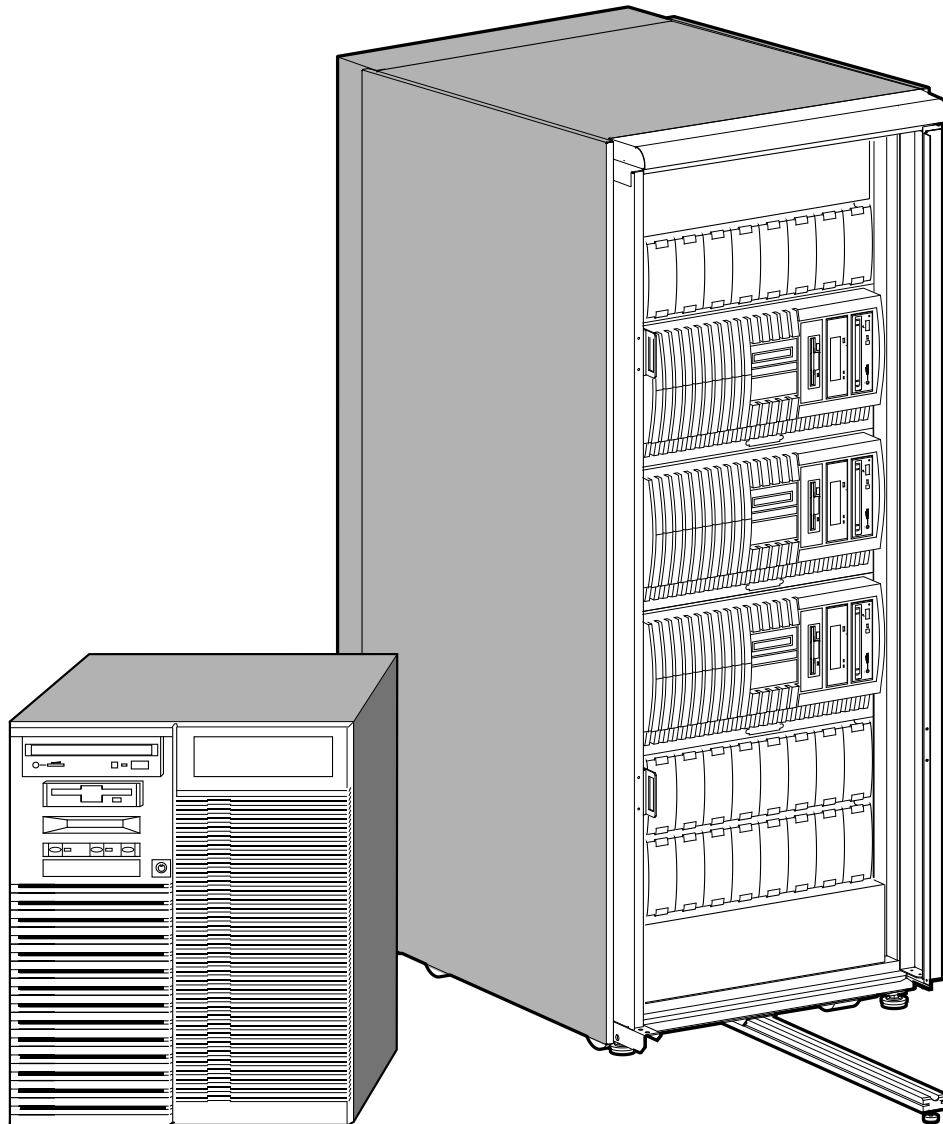

Table of Contents

1

Investment Protection

Flexible System Packages

AlphaServer 1000 4/266 System

AlphaServer 1000 4/266 Cabinet System

2

AlphaServer 1000 4/266 Rackmount System

Features and Benefits

Alpha Processor Card

Model 4/266 CPU Card Features

SIMM Memory Modules

System Board

3

I/O Buses

PCI Bus

EISA Bus

Xbus

Storage Architecture

Removable Storage

Disk Storage

SCSI Storage Expansion

RAID (Redundant Array of Inexpensive Disks)

Clustering for UNIX and OpenVMS

Internet Server on Windows NT and UNIX

Availability and Reliability

Power-Up Self-Test

Power Control System

Dual SCSI Backplanes

Disk Hot Swap

4

Thermal Management

Maintenance

Performance

Sources of Performance Information

Information for Digital Partners

System Features at a Glance

5

System Architecture

6

Physical Characteristics and Operating Environment

7

AlphaServer 1000 System Components

AlphaServer 1000 System Front View

8

AlphaServer 1000 System Side View

9

AlphaServer 1000 System Rear View

10

AlphaServer 1000 Cabinet System Components

Cabinet System Configuration

11

AlphaServer 1000 Rackmount System

Rackmount System Configuration

AlphaServer 1000 4/266 System

The Digital AlphaServer 1000 system is a low-cost, single-processor, PCI/EISA-based server. It is suitable for general-purpose commercial, high-performance application and database, PC LAN, and Internet server environments. With the AlphaServer 1000 server, you can choose from three operating environments—Windows NT, DEC OSF/1, and OpenVMS.

Guaranteed to provide high reliability and availability, the AlphaServer 1000 is ideally suited for organizations with little or no MIS support.

Investment Protection

Based on the 64-bit Alpha RISC architecture, the AlphaServer 1000 server provides investment protection you can count on. You can choose from three popular operating environments—UNIX, Windows NT, and OpenVMS. These operating systems and thousands of applications run more efficiently on the Alpha platform. Designed to be compatible with higher performance microprocessors, the system is in-cabinet CPU upgradeable.

Flexible System Packages

The AlphaServer 1000 system is available in three separate packages—standard, cabinet, and rackmount—to suit a range of computing needs.

AlphaServer 1000 4/266 System

A uniprocessor server, the AlphaServer 1000 4/266 system is a deskside, low-noise system designed to fit easily in office environments where a compact footprint and low to medium disk storage capacities are required. It supports PCI and EISA I/O, up to 1 GB of main memory, and up to 28 gigabytes of in-cabinet storage.

Figure 1 AlphaServer 1000 Deskside System

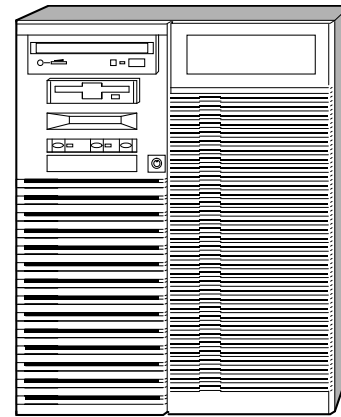

AlphaServer 1000 4/266 Cabinet System

The AlphaServer 1000 4/266 CAB system puts multiple systems in a single cabinet. It is designed for office or satellite equipment rooms where floor space is at a premium, where large disk storage arrays are required, and where high availability is imperative. This system houses up to seven internal drives and provides hot swap capabilities.

AlphaServer 1000 4/266 Rackmount System

The AlphaServer 1000 4/266 RM system is a rackmountable unit with the same features as the standard system, except that most of the storage resides outside the main system. The rackmount unit mounts easily in a standard ANSI/EIA 19-inch rack and can accommodate four storage shelves from the SCSI expansion.

Figure 3 AlphaServer 1000 Rackmount System

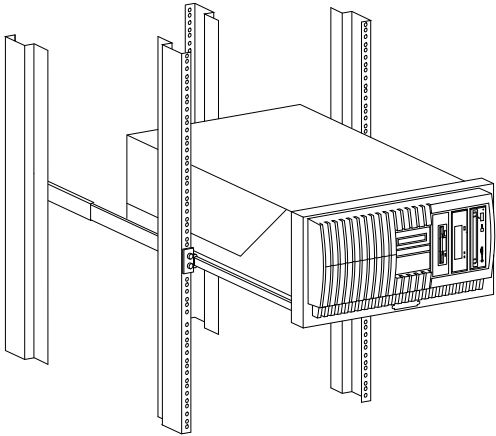

Features and Benefits

The AlphaServer 1000 4/266 provides the following features for fast application processing, high availability, and low maintenance.

- **System Performance**

The system design uses industry-standard SIMMs, disk drives, and PCI and EISA I/O buses to deliver maximum system performance.

- **Reliability and Availability**

Built-in fan, power, and temperature sensors monitor the server, and the LCD control panel indicates system status. The ECC memory allows recovery from most cache and memory errors. A dual SCSI backplane allows fully redundant disk subsystems. Fully redundant power supplies distinguish this low-end server from all other servers on the market.

- **System Expansion**

System memory can be upgraded from 16 megabytes to 1 GB using SIMM options. Up to three PCI and up to eight EISA slots accommodate industry-standard options. An on-board Fast SCSI-2 controller allows direct connection to CD-ROM, tape, and disk drives. An on-board SVGA controller supports enhanced graphics without use of an expansion slot.

- **Server Management**

Remote management is handled through a serial modem link. A system administrator can dial through a modem, remotely run diagnostics, configure the system, and recommend a fix.

- **Reduced Service Costs**

Because of its high reliability, the system requires minimal MIS support. In most cases, it can be self-serviced by the customer. The system also comes with a warranty.

Figure 2 AlphaServer 1000 CAB System

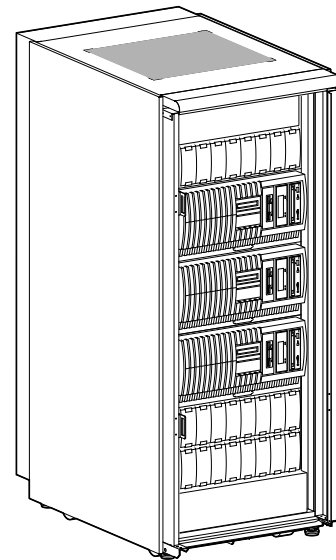

- **Warranty**

A three-year, on-site server hardware warranty is standard. The warranty provides on-site, next business day response time—the best hardware warranty in the industry.

Alpha Processor Card

The AlphaServer 1000 system CPU is designed to be upgradeable with future Alpha microprocessors. The card contains the processor, a second-level cache, and the chipset that interfaces the CPU to the 128-bit wide ECC-protected memory subsystem and to the 32-bit PCI bus. Both the memory and the PCI-based I/O subsystem are located on the motherboard.

The Alpha CPU chip has the following features:

- All instructions 32 bits long with a regular instruction format
- Floating-point unit, supports DEC and IEEE floating-point data types
- 32 integer registers, 64 bits wide
- 32 floating-point registers, 64 bits wide
- On-chip, direct-mapped, write-through physical data cache
- On-chip, direct-mapped, read-only virtual instruction cache
- On-chip I-stream translation buffer
- On-chip D-stream translation buffer

Model 4/266 CPU Card Features

The CPU card has the following features:

- 266-MHz processing speed
- 8 KB of serial ROM, which provides the CPU with power-up code
- 2 MB of direct-mapped, ECC-protected second-level cache

SIMM Memory Modules

The system supports 20 single in-line memory module (SIMM) connectors on the system board. System memory can be configured for up to 1 Gbytes. The SIMM connectors are

grouped in four memory banks consisting of five memory modules, including one for ECC (error correction code).

- The system supports 16-MB, 32-MB, 64-MB, and 128-MB and 256 MB modules.
- When a memory option is installed in a bank, a memory module must be installed in all of the connectors in that bank.
- All modules within a bank must be of the same capacity.
- Bank 0 must contain a memory option.

System Board

The AlphaServer 1000 server provides the following I/O functionality:

- SVGA controller supports high-resolution graphics and text display for a variety of color CRT monitors without using an expansion slot
- PCI-to-EISA Intel bridge chip set
- PCI-based SCSI controller provides a Fast SCSI-2 interface
- 1 MB of FlashROM, which contains the diagnostics and firmware
- Bi-directional parallel port, two serial ports, and floppy disk controller
- Keyboard and mouse interface
- Time of year (TOY) clock
- 8 KB of NVRAM to store system configuration
- PC-style speaker

I/O Buses

PCI and EISA I/O accommodate industry-standard option cards.

PCI Bus

The PCI (Peripheral Component Interconnect) is the preferred I/O bus for high-performance I/O options. The PCI bus has the following characteristics:

- Fully compliant with *PCI Version 2 Specification*
- Operates at 33 MHz
- Supports up to three PCI option slots
- Supports on-board SCSI-2 controller

EISA Bus

The EISA (Extended Industry Standard Architecture) bus is used for several medium-performance options, such as modems and other peripherals. It also controls the Xbus interface. The EISA bus is backward-compatible with ISA bus options, provided the operating system supports the device.

The EISA bus has the following characteristics:

- Operates at 8.33 MHz
- Supports up to eight EISA/ISA slots
- All slots are bus master slots

Xbus

The Xbus includes the real time clock, the NVRAM, the FlashROM, and the operator control panel interface.

Storage Architecture

The AlphaServer 1000 server storage architecture is designed for maximum performance and easy operation. All storage bays are accessible from the front of the system. If the system

is configured with RAID, modules can be added or removed while the system is running.

Removable Storage

The system supports a 3.5-inch floppy drive, 5.25-inch CD-ROM drive, a number of optional tape drives for a 5.25-inch bay.

Disk Storage

The system has one internal BA350 StorageWorks shelf that supports up to seven 3.5-inch storage devices. The SCSI backplane can be configured to run as a single bus or a dual bus. The backplane is "wide ready" and can accommodate faster performing wide disks.

SCSI Storage Expansion

The system supports optional external SCSI expansion. SCSI bus expansion ports on the rear of the system enable the bus to extend outside the system. StorageWorks modules add up to 440 GB of storage.

RAID (Redundant Array of Inexpensive Disks)

The system can be configured with optional RAID controllers to organize disk data cost-effectively, improve performance, and provide high levels of storage integrity. Optional RAID controllers have the following features:

- Support of drive hot swap
- Automatic rebuild after hot swap
- Optional write cache

Clustering for UNIX and OpenVMS

As performance and availability requirements grow, the AlphaServer 1000 server can support full clustering capabilities. Clustering allows multiple computer system to share disks and spread the computing load across multiple CPUs. Through clustering, a collection of processors and storage elements can operate as one system, and you can integrate PC-based clients and applications for increased data availability.

Internet Server on Windows NT and UNIX

The AlphaServer 1000 system comes ready with all popular modes of connection to the Internet. It can also be pre-configured with the most commonly used Internet applications, allowing customers immediate access to Internet information, news groups, and electronic mail.

Availability and Reliability

The AlphaServer 1000 system is the only low-end server in the industry to offer ECC cache, optionally available fully redundant power supplies, and a dual SCSI backplane.

Power-Up Self-Test

At initialization, the system performs a self-test that verifies its functionality.

Power Control System

The power system uses several power conditioning functions to protect against high-voltage transients. The power system is capable of withstanding under-voltage conditions and power

interruptions of any duration on one or more current phases without causing physical damage. The power system continuously monitors the AC power line at the AC input box for AC line spikes, voltage fluctuations, and so forth.

For further protection, an optional second power supply provides redundant power should the first power supply fail.

Dual SCSI Backplanes

Using additional SCSI controllers allows for fully redundant disk subsystems within a dual-SCSI backplane configuration.

Disk Hot Swap

In-cabinet disks support disk hot swap. Hot swap is the removal of the disk or disks from any one of the storage compartments while the rest of the system remains powered on and continues to operate.

This feature contributes significantly to system availability. Since many disk problems can be resolved without shutting down the entire system, users lose access only to the disks that are removed. The hot swap feature is available only within RAID configurations.

Thermal Management

The system's thermal management is designed to maximize system reliability. Sensors monitor internal system temperature, fan failure, and power supply temperature and shut down the system if necessary.

Maintenance

The system covers are designed to slide off, making components easy to access. To protect users, a power interlock switch automatically shuts down the system if the top cover is removed. The CPU, memory, PCI, and EISA options are plug-in cards that require no special switch or jumper settings for normal operation.

Performance

Digital evaluates the performance of the AlphaServer 1000 server in an ongoing program of performance engineering, using industry-standard benchmarks that allow comparisons across major vendors' systems. These benchmarks against competitive systems are based on comparable or close CPU performance, coupled with comparable memory and disk expandability.

Remember that system performance depends on application characteristics. Thus, benchmark information is one helpful "data point" to be used in conjunction with other purchase criteria such as features, service, and price.

Sources of Performance Information

You can access performance information from Digital using your fax machine as well as several online sources.

- *InstaFACTS*. The InstaFACTS fax service delivers information directly to your fax machine. Call 1-800-723-4431 (through a touch-tone phone in the U.S.A. and Canada) and 908-885-6426 (outside the U.S.A. and Canada). A catalog of documents is available from which you can order an abbreviated table of performance

information, including Digital's performance briefs and flashes, TPC results, AIM results, and graphic results.

- *Internet*. Access performance documents from gatekeeper.dec.com. The directory name is pub/DEC/DECinfo/performance/sys.
- *CompuServe*. Type GO VAXFORUM and look in the "hardware" library. For more information contact Doyle Myers at Internet address doyle@wrq.com or 76703.4403@compuserve.com.
- *World Wide Web*. The document URL (Uniform Resource Locator) is <http://www.digital.com/info/performance/sys>.

Information for Digital Partners

Digital partners can access Digital's Integrated Repository from DECGenisis V1.2. *Digital Today, Business Partner Edition*, occasionally contains articles on performance of Alpha systems and announcements of available documents.

System Features at a Glance

Table 1 summarizes the AlphaServer 1000 4/266 system features and specifications.

Table 1 AlphaServer 1000 4/266 Server Features

Hardware	
Environment	Office environment (Class B)
Processor	One Alpha 21064, 64-bit RISC
Processor clock rate	266 MHz
Bcache size	2 MB
Memory (min./max.)	16MB/1 GB
Max. I/O throughput	132 MB/s (PCI) 33 MB/s (EISA)
Floppy disk	1.44 MB
CD-ROM	600 MB
I/O support	2 PCI slots 7 EISA/ISA slots 1 PCI or EISA/ISA slot
High Availability	
System	Optional redundant power, hot swap disk, ECC cache, ECC memory, RAID, thermal management
Server management	Remote access to system, unique system ID, error logs, firmware upgradeable
Operating systems	Windows NT, OpenVMS, DEC OSF/1
OpenVMS clusters	Ethernet, DSSI, FDDI
AdvantageClusters (UNIX)	Yes
Networking	Ethernet, Token Ring, FDDI
Storage	Fast SCSI-2, RAID
Maintenance	
Three-year on-site warranty	

System Architecture

Figure 4 shows the AlphaServer 1000 system architecture.

Figure 4 System Architecture

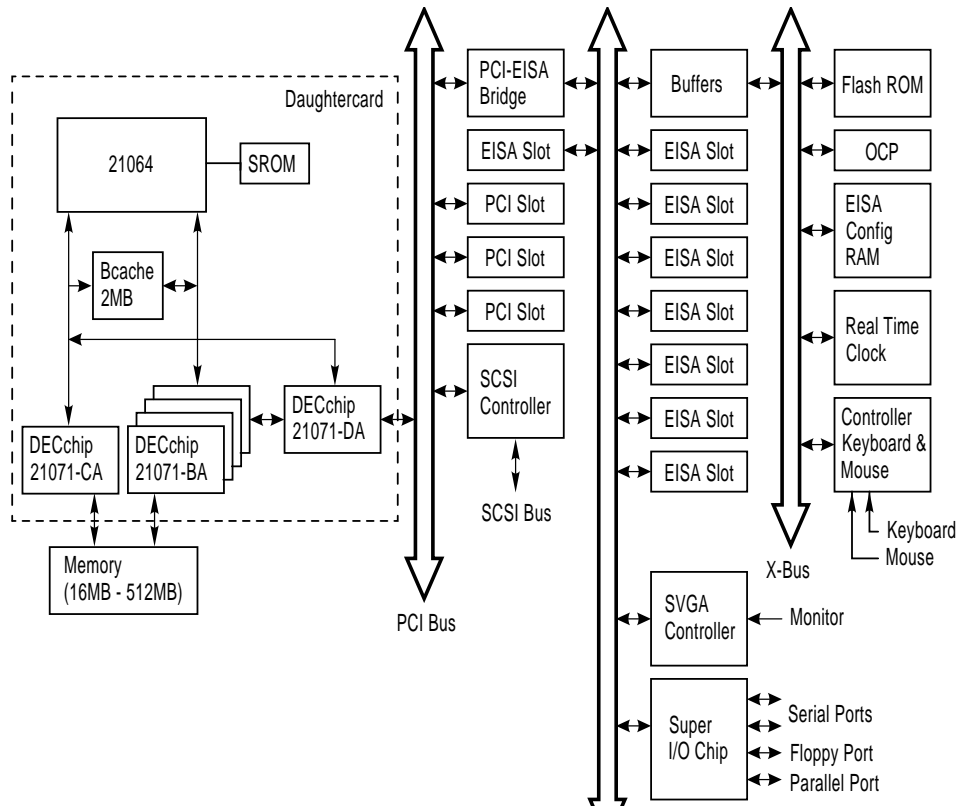

Physical Characteristics and Operating Environment

Table 2 lists the physical characteristics and operating conditions for the AlphaServer 1000 4/266 system and AlphaServer 1000 4/266 RM and CAB systems.

Table 2 AlphaServer 1000 Physical Characteristics

Characteristic	AlphaServer 1000 Base Model	AlphaServer 1000 RM and CAB
Width	35.3 cm (14.1 in)	48.2 cm (19 in)
Length	53 cm (21 in)	63.5 cm (25 in) system chassis only; 73.7 cm (29 in) system chassis and rackmount assembly
Height	44 cm (17.4 in)	26.7 cm (10.5 in)
Weight – maximum	42 kg (93 lbs)	24.9 kg (55 lbs) system only; 29 kg (65 lbs) system and rackmount assembly
Operating environment	Class B	Class B
Operating temperature	10°C–40°C 50°F–104°F	10°C–35°C 50°F–95°F
Operating humidity	20%–80%	20%–80%
Nominal voltage	110–120 V 220–240 V	110–120 V 220–240 V
Frequency range	50–60 Hz	50–60 Hz
Current	8.5/4.0 Amperes (one power cord); 7.0/3.5 Amperes (two power cords)	8.5/4.0 Amperes (one power cord); 7.0/3.5 Amperes (two power cords)

AlphaServer 1000 System Components

Figures 5 to 9 show the main components of the AlphaServer 1000 4/266 system.

Figure 5 AlphaServer 1000 System Front View

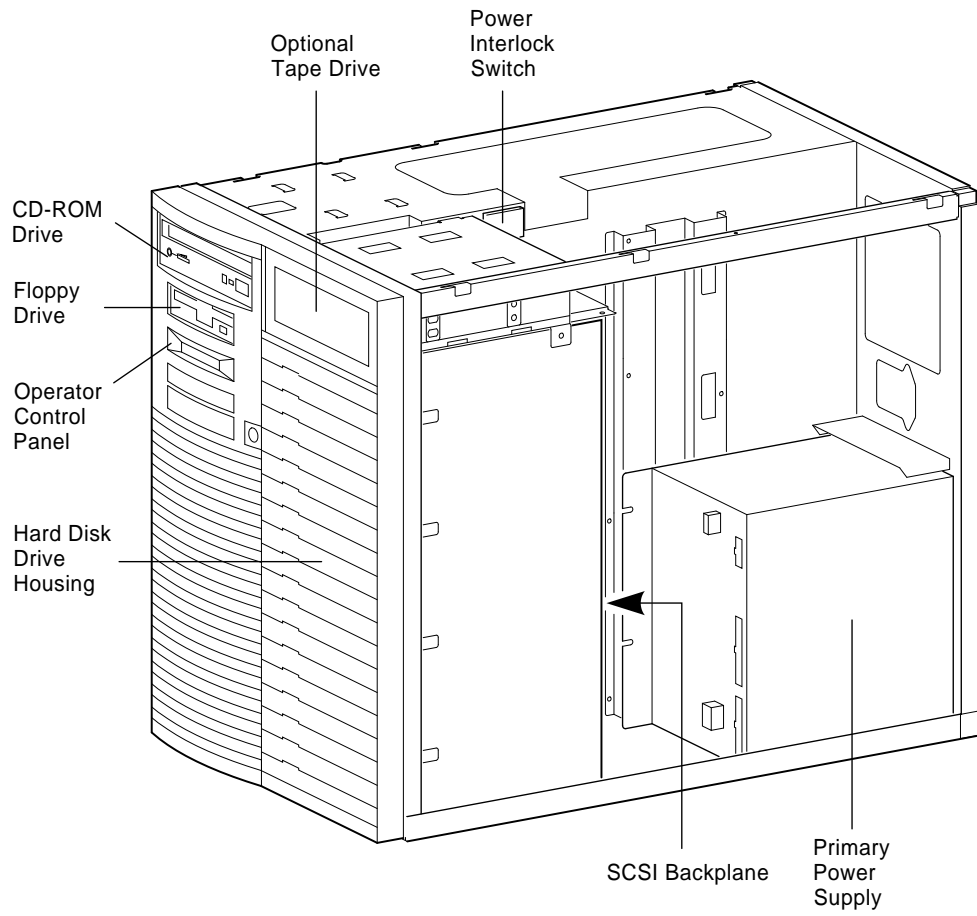

Figure 6 AlphaServer 1000 System Side View

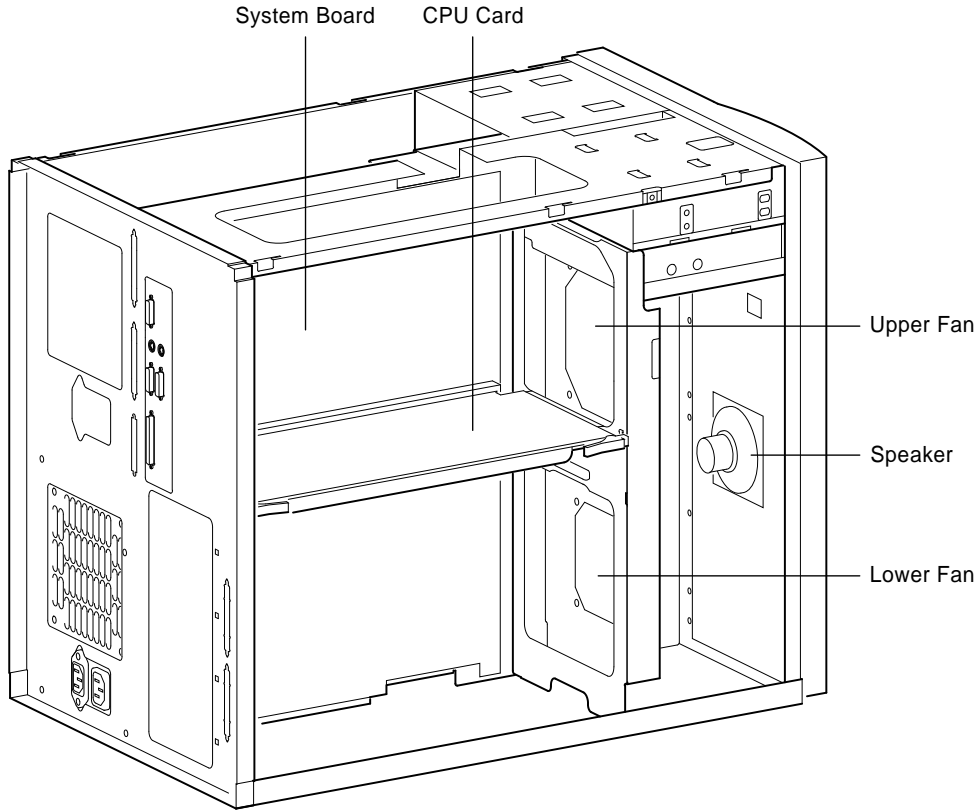
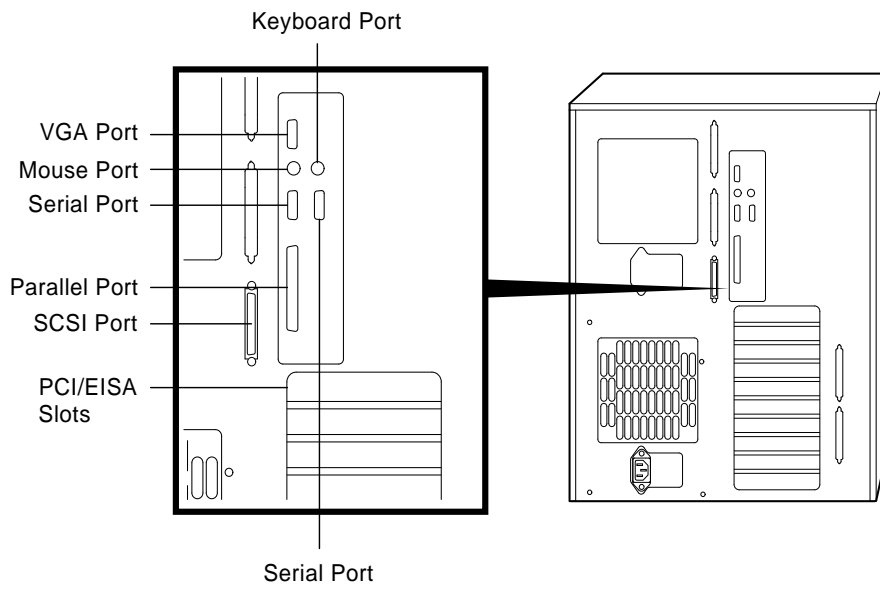

Figure 7 AlphaServer 1000 System Rear View



AlphaServer 1000 Cabinet System Components

Figure 8 shows the AlphaServer 1000 4/266 CAB system.

Figure 8 AlphaServer 1000 CAB System Components

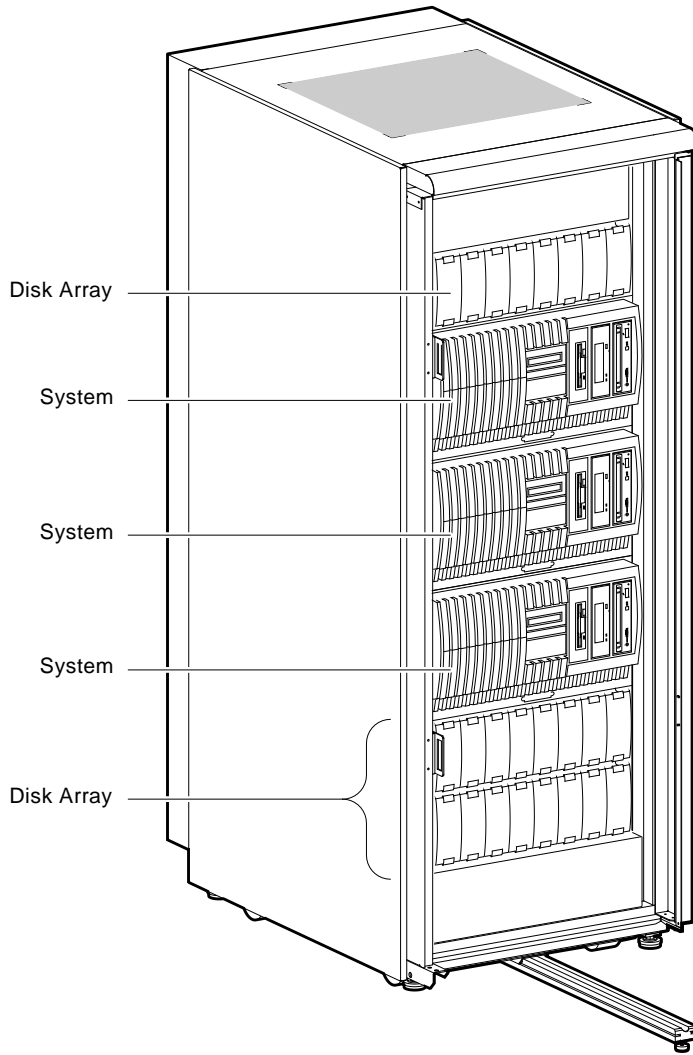

Cabinet System Configuration

Configuration	Cabinet System
Chassis	Widetower
Internal drives	7
Hot swap	Yes

AlphaServer 1000 Rackmount System

Figure 9 shows the AlphaServer 1000 4/266 RM system.

Figure 9 AlphaServer 1000 RM System

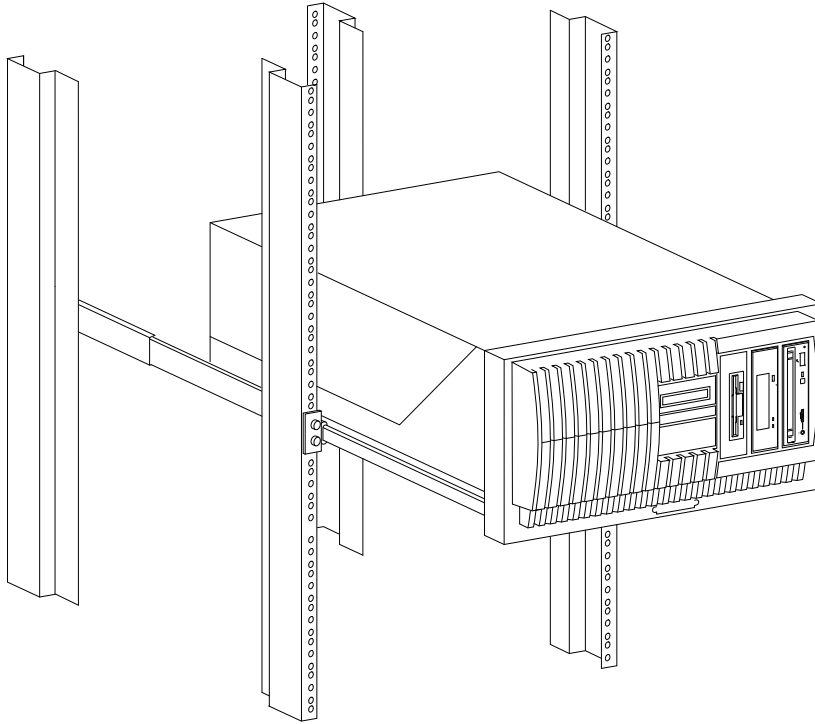

Rackmount System Configuration

Configuration	Cabinet System
Chassis	Tower
Internal drives	3
Hot swap	No



Digital believes the information in this publication is accurate as of its publication date; such information is subject to change without notice. Digital is not responsible for any inadvertent errors. Digital will conduct its business in a manner that conserves the environment and protects the safety and health of its employees, customers, and the community.

The following are trademarks of Digital Equipment Corporation: AlphaServer, AlphaGeneration, the AlphaGeneration logo, the DIGITAL logo, DEC 7000, DSSI, OpenVMS, POLYCENTER, StorageWorks, ULTRIX and VAX 7000. OSF/1 is a registered trademark of the Open Software Foundation. SPEC, SPECint92, and SPECfp92 are registered trademarks of Standard Performance Evaluation Corporation. UNIX is a registered trademark, licensed exclusively through X/Open Company. Windows and Windows NT are trademarks of Microsoft Corporation.