

VT 220

Pocket Service Guide

1st Edition, August 1983
2nd Edition, August 1984
3rd Edition, August 1986

Copyright © 1983, 1984, 1986
by Digital Equipment Corporation.
All Rights Reserved.

Printed in U.S.A.

The reproduction of this material, in part or whole, is strictly prohibited. For copy information, contact the Educational Services Department, Digital Equipment Corporation, Maynard, Massachusetts 01754.

The information in this document is subject to change without notice. Digital Equipment Corporation assumes no responsibility for any errors that may appear in this document.

AT&T is a trademark of American Telephone and Telegraph Company.

The following are trademarks of Digital Equipment Corporation, Maynard, Massachusetts.

digital	DECwriter	RSTS
DEC	DIBOL	RSX
DECmate	MASSBUS	UNIBUS
DECnet	PDP	VAX
DECsystem-10	P/OS	VMS
DECSYSTEM-20	Professional	VT
DECUS	Rainbow	Work Processor

CONTENTS

INTRODUCTION

1 TESTING AND TROUBLESHOOTING

1.1	General	1
1.2	Testing and Troubleshooting	1
1.3	Power-Up Self-Test	1
1.4	EIA Port Data Lines Loopback Self-Test	4
1.5	Printer Port External Loopback Self-Test	6
1.6	EIA Port Control Lines Loopback Self-Test	7
1.7	20 mA Port Loopback Self-Test	8
1.8	Screen Alignment Test	9
1.9	VT22X Modem Option Problems	9
1.9.1	Analog Loop Test	10
1.9.2	Remote Loop Test	12
1.10	Printer Problems	14
1.11	Self-Test Error Codes	15
1.12	Troubleshooting General Problems	16

2 REMOVING AND REPLACING FRUs (MODELS A, B, AND C)

2.1	General	20
2.2	Access Cover (All Models)	21
2.3	Terminal Controller Board	25
2.4	Power Supply/Monitor Board	26
2.5	Flyback Transformer	30
2.6	CRT Assembly	34
2.7	Keyboard (All Models)	35
2.8	VT22X Modem Option (All Models)	38
2.8.1	Installing the VT22X Modem	38
2.8.2	Installing the VT22X Modem Cabling	40
2.9	Recommended Spares List (Models A, B, and C)	43

**3 REMOVING AND REPLACING FRUs
(MODELS D, E, AND F)**

3.1	General	44
3.2	Access Cover	45
3.3	Terminal Controller Board	45
3.4	Power Supply/Monitor Board	46
3.5	Transformer	52
3.6	CRT/Bezel Assembly	55
3.7	Keyboard	55
3.8	VT22X Modem Option	55
3.9	Recommended Spares List (Models D, E, and F)	55

4 VIDEO MONITOR ALIGNMENT

4.1	General	57
4.2	Monitor Adjustments	57
4.2.1	Initial Preparations	58
4.2.2	Character Quality	60
4.2.2.1	Brightness	60
4.2.2.2	Contrast	60
4.2.2.3	Vertical Linearity	61
4.2.2.4	Focus	61
4.2.3	Horizontal Hold (Display Instability Adjustment)	61
4.2.4	Display Centering	62
4.2.4.1	Horizontal Centering	62
4.2.4.2	Vertical Centering	62
4.2.5	Display Size	63
4.2.5.1	Horizontal Width	63
4.2.5.2	Vertical Height	64

5 SET-UP REFERENCE MATERIAL

5.1	Using Set-Up	65
5.2	Saving or Recalling Set-Up Values	65

A VT220 DOCUMENTATION

B FRU EXPLODED VIEW DRAWING

C CABLE INFORMATION

D PHYSICAL/FUNCTIONAL DIAGRAM

FIGURES

1-1	Indication of Successful Power-Up Self-Test	1
1-2	VT220 Rear Connector Panel	5
1-3	VT22X Modem	9
1-4	Analog Loop Test	11
1-5	Remote Loop Test	12
2-1	Identifying the VT220 Model	20
3-1	Identifying the VT220 Model	44
4-1a	Video Adjustment Locations (Models A, B, and C)	58
4-1b	Video Adjustment Locations (Models D, E, and F)	59
4-2	Brightness, Contrast, and Tilt Controls ...	60
4-3	Centering Adjustments	63
4-4	Horizontal Width Adjustment	64
B-1	VT220 FRUs, Models A, B, and C (Exploded View)	68
B-2	VT220 FRUs, Models D, E, and F (Exploded View)	69
C-1	Cable Summary	70
D-1	Physical/Functional Diagram (Models A, B, and C)	73
D-2	Physical/Functional Diagram (Models D, E, and F)	74

TABLES

1-1	Self-Test Chart	2
1-2	VT220 Monitor Display Error Codes	15
1-3	VT220 LED Error Codes	16
1-4	VT220 Troubleshooting Chart	17
2-1	Recommended Spares List (Models A, B, and C)	43
3-1	Recommended Spares List (Models D, E, and F)	56
C-1	Interface Cables	71
C-2	Modem Control Selections	72

INTRODUCTION

ABOUT THIS GUIDE

This pocket service guide describes the following topics on servicing the VT220 video terminal.

Testing and troubleshooting the field replaceable units (FRUs)

FRU removal and replacement

Video monitor alignment

Set-up reference material

Related documentation

Cable information

Physical/functional diagram

WARNINGS, CAUTIONS, AND NOTES

Warnings, cautions, and notes appear throughout this pocket service guide. They are defined as follows.

- | | |
|----------------|---|
| WARNING | Contains information essential to the safety of personnel. |
| CAUTION | Contains information essential to the safety of the equipment and software. |
| NOTE | Contains an important message alerting you to information you should be aware of. |

Information you type at the keyboard appears in **bold** type.

Information that appears on the screen appears in **this** type.

THE VT220

The VT220 is a general-purpose video terminal for text. The VT220 is compatible with the VT102. An optional VT22X modem mounts under the terminal.

The VT220 supports different language versions of the LK201 corporate keyboard and works in three operating states, selected from the keyboard: set-up, on-line, and local.

The antiglare, 12-inch (305 mm) monochrome monitor can display 24 rows of text in an 80- or 132-column format. The monitor tilt mechanism lets the user adjust the screen for optimum viewing comfort.

The VT220 has three standard interface connectors: two asynchronous serial ports and one 20 mA port. You can use the EIA host port or 20 mA host port to connect the terminal to a host computer. The EIA host port is a 25-pin (EIA RS232C) male connector that connects the terminal to the VT22X modem option. The 20 mA host port is an 8-pin 20 mA female connector. The third interface connector is the printer port. This port is a 9-pin (EIA RS232C) male connector used to connect the terminal to a printer. The VT220 terminal operates only on full-duplex, asynchronous communication lines.

HOW TO IDENTIFY VT220 MODELS

The VT220 comes in two basic variations.

- Models A, B, and C
- Models D, E, and F

Both variations operate the same. The differences are internal.

To identify the model you are servicing, check the model number on the rear of the terminal (Figure I-1).

NOTE

If the letter C (or any successive letter, such as D) appears in the serial number, the terminal is a VT220 D, E, or F model.

Examples:

TA629C0001, TA641D0001, TA712E0001

Chapter 2 describes the removal and replacement procedures for VT220 models A, B, and C. Some of these procedures are the same for models D, E, and F.

Chapter 3 describes the removal and replacement procedures that are different for models D, E, and F.

Testing and troubleshooting procedures (Chapter 1) and monitor alignment procedures (Chapter 4) are the same for all VT220 models.

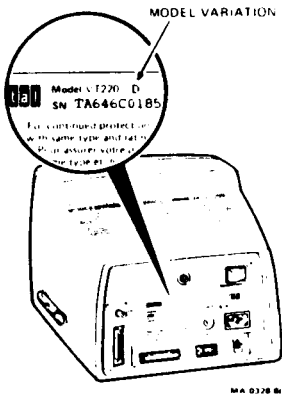

Figure I-1 Identifying the VT220 Model

TOOLS REQUIRED

You need the following tools to service the VT220.

Tool	Part Number
Slotted screwdriver, 1/4 inch	29-10983-00
Phillips screwdriver, no. 2	29-11005-00
Tuning wand	29-23189-00
Video alignment tool	29-23190-00
Digital screen cleaner	49-01607-01
Diagonal cutters	29-10206-00
Anode discharge tool	29-24717-00
Scribe	None
Ruler	29-25342-00
Video alignment template	29-24371-00

1 TESTING AND TROUBLESHOOTING

1.1 GENERAL

This chapter contains the information needed to perform the self-test functions and troubleshoot the VT220 video terminal.

1.2 TESTING AND TROUBLESHOOTING

There are a series of internal self-tests to help you isolate failures to the field replaceable units (FRUs). (See Appendix B.) Table 1-1 lists the self-tests.

If a test finds a faulty FRU, adjust or replace the faulty unit. Then repeat all of the tests listed in Table 1-1 to ensure that the terminal operates correctly.

1.3 POWER-UP SELF-TEST

This test checks the terminal's internal memory, the keyboard, and the video circuitry. The test also makes a partial check of the communication and printer ports to see if they are operating correctly.

A successful power-up self-test ends when the following occur.

1. The keyboard LED indicators (Figure 1-1) are off.
2. The keyboard generates a bell tone.
3. A VT220 OK message enclosed by a rectangle appears on the screen (Figure 1-1). This message disappears from the screen (1) the moment any character except XON is received by your terminal, (2) if you press the Set-Up key, or (3) if you let 30 minutes elapse.

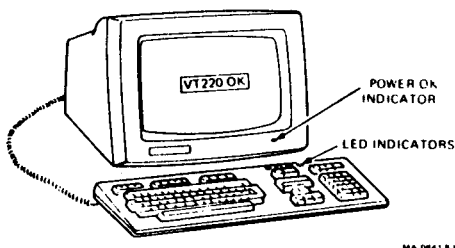

Figure 1-1 Indication of Successful Power-Up Self-Test

2 TESTING AND TROUBLESHOOTING

Table 1-1 Self-Test Chart

Self-Tests	Prerequisites	Sequence*
Power-up (Para. 1.3)	None	Turn terminal power on.
Power-up (invoked after terminal is operating)	<ul style="list-style-type: none"> ● Set-up <ul style="list-style-type: none"> - Local - VT100 	Once: ESC [4 ; 1 y Continuously: ESC [4 ; 1 ; 9 y
EIA port data lines loopback (Para. 1.4)	<ul style="list-style-type: none"> ● Set-up <ul style="list-style-type: none"> - Local - VT100 ● EIA loopback connector 	Once: ESC [4 ; 2 y Continuously: ESC [4 ; 2 ; 9 y
Printer port external loopback (Para. 1.5)	<ul style="list-style-type: none"> ● Set-up <ul style="list-style-type: none"> - Local - VT100 ● Printer port loopback connector 	Once: ESC [4 ; 3 y Continuously: ESC [4 ; 3 ; 9 y
EIA port control lines loopback (Para. 1.6)	<ul style="list-style-type: none"> ● Set-up <ul style="list-style-type: none"> - Local - VT100 ● EIA loopback connector 	Once: ESC [4 ; 6 y Continuously: ESC [4 ; 6 ; 9 y
20 mA port loopback (Para. 1.7)	<ul style="list-style-type: none"> ● Set-up <ul style="list-style-type: none"> - Local - VT100 ● 20 mA loopback connector 	Once: ESC [4 ; 7 y Continuously: ESC [4 ; 7 ; 9 y
Screen alignment (Para. 1.8)	-	ESC # 8
Execute all above tests except 20 mA port loopback test and screen alignment.	See individual tests.	ESC [4 ; 0 y

* Do not type spaces between the parameters of any escape sequence. The parameters are shown with spaces for clarity only.

If an error occurs, check your monitor first. Your screen will display VT220 and an error message. Table 1-2 defines the error message. (See Paragraph 1.11.)

If an error occurs that makes it impossible for you to continue operating your monitor, the keyboard LED indicators will display an error code. Table 1-3 defines these error codes. (See Paragraph 1.11.)

If other problems occur, see Paragraph 1.12. Table 1-4 lists common symptoms and their probable causes, and suggests corrective actions.

Start the power-up self-test with one of the following two methods.

1. Turn the power to the VT220 on. (The power-up self-test runs automatically each time the terminal is turned on.)
2. Type one of the following sequences to run the power-up self-test. (Read the following note first.)

NOTE

If you are already operating your terminal, enter set-up. Then put your terminal in local and in VT100 mode.

ESC [4 ; 1 y (Performs test once.)

ESC [4 ; 1 ; 9 y (Performs test continuously.)

NOTE

The continuously running test ends only if an error occurs or you turn off the power. The keyboard does not generate a bell tone during a continuously running test.

When you run the power-up self-test, the following occurs.

- All keyboard LED indicators blink on and off intermittently.
- A bell tone sounds if the test is completed successfully.
- A VT220 OK message appears on the screen.

1.4 EIA PORT DATA LINES LOOPBACK SELF-TEST

For this test, you connect the terminal's transmit and receive lines together with a data loopback connector (Figure 1-2). The terminal sends a predefined set of characters on its transmit line and receives them on its receive line. Then the terminal compares the output characters to the input characters. If the characters do not match, an error message appears on the screen. (See Paragraph 1.10.)

A successful test ends when the following occur.

1. The keyboard LED indicators are off.
2. The keyboard generates a bell tone.
3. A VT220 OK message appears on the screen.

Run the EIA data lines loopback self-test as follows.

1. Enter set-up and put your terminal in local and in VT100 mode. Then exit set-up.
2. Connect the data loopback connector (PN 12-15336-00) to the host port (Figure 1-2).
3. Type one of the following sequences to perform the data loopback self-test.

ESC [4 ; 2 y (Performs test once.)

ESC [4 ; 2 ; 9 y (Performs test continuously.)

NOTE

The continuously running test ends only if an error occurs or you turn off the power. The keyboard does not generate a bell tone during a continuously running test.

If the EIA port data lines loopback self-test finds an error, your screen displays the following message. (See Paragraph 1.11.)

VT220 EIA Port Data Error - 2

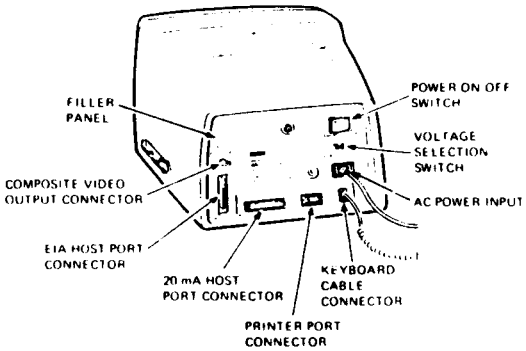

20mA LOOPBACK CONNECTOR

PN 70 15503 00



FROM PIN	TO PIN
1	3
2	7
5	8

PRINTER PORT LOOPBACK CONNECTOR

PN 29 24794 00



FROM PIN	TO PIN
2	3
5	6

DATA LOOPBACK CONNECTOR

PN 12 15336 00

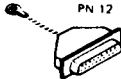

FROM PIN	TO PIN	TO PIN
2	3	15
4	5	8
20	6	22
19	12	17

WA 0846 03A

Figure 1-2 VT220 Rear Connector Panel

1.5 PRINTER PORT EXTERNAL LOOPBACK SELF-TEST

For this test, you connect the printer port transmit and receive lines together with the printer port loopback connector (Figure 1-2). The terminal sends a predefined set of characters on its transmit line and receives them on its receive line. Then the terminal compares the input characters with the output characters. If the characters do not match, an error message appears on the screen. (See Paragraph 1.11.)

A successful test ends when the following occur.

1. The keyboard LED indicators are off.
2. The keyboard generates a bell tone.
3. A VT220 OK message appears on the screen.

Run the printer port loopback self-test as follows.

1. Enter set-up and put your terminal in local and in the VT100 mode. Then exit set-up.
2. Connect the printer port loopback connector (PN 29-24794-00) to the printer port (Figure 1-2).
3. Type one of the following sequences to perform the printer port external loopback test.

ESC [4 ; 3 y (Performs test once.)

ESC [4 ; 3 ; 9 y (Performs test continuously.)

NOTE

The continuously running test ends only if an error occurs or you turn off the power. The keyboard does not generate a bell tone during a continuously running test.

If the printer port loopback self-test finds an error, your screen displays the following message. (See Paragraph 1.11.)

VT220 Printer Port Error - 6

1.6 EIA PORT CONTROL LINES LOOPBACK SELF-TEST

This test checks data terminal ready, request to send, carrier detect, data set ready, and clear to send.

A successful test ends when the following occur.

1. The keyboard LED indicators are off.
2. The keyboard generates a bell tone.
3. A VT220 OK message appears on the screen.

Run the EIA port control lines loopback self-test as follows.

1. Enter set-up and put your terminal in local and in VT100 mode. Then exit set-up.
2. Install an EIA loopback connector (PN 12-15336-00) to the EIA host port (Figure 1-2).
3. Type one of the following sequences to perform the EIA port control lines loopback self-test.

ESC [4 ; 6 y (Performs test once.)

ESC [4 ; 6 ; 9 y (Performs test continuously.)

NOTE

The continuously running test ends only if an error occurs or you turn off the power. The keyboard does not generate a bell tone during a continuously running test.

If the EIA port control lines loopback self-test finds an error, your screen displays the following message. (See Paragraph 1.11.)

VT220 EIA Port Controls Error - 3

1.7 20 mA PORT LOOPBACK SELF-TEST

For this test, you connect the terminal's transmit and receive lines together with a 20 mA data loopback connector (Figure 1-2). The terminal sends a predefined set of characters on its transmit line and receives them on its receive line. Then the terminal compares the output characters to the input characters. If the characters do not match, an error message appears on the screen. (See Paragraph 1.11.)

A successful test ends when the following occur.

1. The keyboard LED indicators are off.
2. The keyboard generates a bell tone.
3. A VT220 OK message appears on the screen.

Run the 20 mA port loopback self-test as follows.

1. Enter set-up and put your terminal in local and in VT100 mode. Then exit set-up.
2. Connect the 20 mA loopback connector (PN 70-15503-00) to the 20 mA port (Figure 1-2).
3. Type one of the following sequences.

ESC [4 ; 7 y (Performs test once.)

ESC [4 ; 7 ; 9 y (Performs test continuously.)

NOTE

The continuously running test ends only if an error occurs or you turn off the power. The keyboard does not generate a bell tone during a continuously running test.

If the 20 mA port loopback self-test finds an error, your screen displays the following message. (See Paragraph 1.11.)

VT220 20 mA Port Error - 5

1.8 SCREEN ALIGNMENT TEST

The screen alignment test fills the screen with uppercase E's for making display height, width, and linearity adjustments.

Run the screen alignment self-test as follows.

1. Enter set-up and select the following.
 - a. 80 columns per line
 - b. VT100 mode
 - c. Local
 - d. Reverse video

Then exit set-up.

2. Type **ESC # 8**. (Your screen will display all capital E's in reverse video.)
3. See Chapter 3 for a complete description of all monitor adjustments used with this test pattern.
4. To remove the test pattern from the screen, enter set-up and select **Clear Display**.

1.9 VT22X MODEM OPTION PROBLEMS

The VT22X modem (Figure 1-3) has a test indicator (labeled **TEST**) and two test pushbuttons (labeled **ANALOG LOOP** and **REMOTE LOOP**).

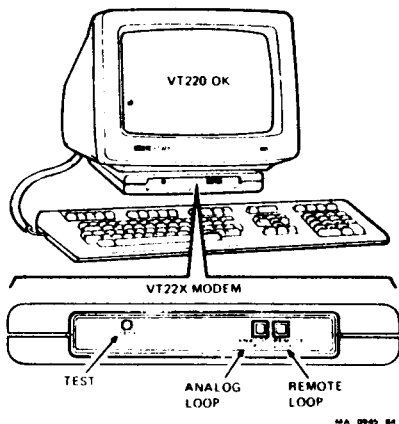

Figure 1-3 VT22X Modem

If there are problems with VT22X modem communication, perform the following steps.

NOTE

The VT22X modem does not have autodial, and does not interpret pushbutton telephone codes (DTMF codes). Do not troubleshoot failures of these nonfunctions.

1. Perform the analog loop test in Paragraph 1.9.1. If this test fails, perform step 2. If the test is successful, perform step 3.
2. If the analog loop test fails, perform the EIA host port loopback test in Paragraph 1.4. If this loopback test fails, follow directions in Paragraph 1.4 to further isolate the VT220 terminal fault. If this loopback test is successful, replace either the cable connecting the VT22X modem to the VT220 terminal, or the VT22X modem to isolate the FRU at fault.
3. If the analog loop test is successful, perform the remote loop test in Paragraph 1.9.2 for both modems in a faulty communication link. You must run separate remote loop tests, one test for each modem, to test the remote communications in both directions.

1.9.1 Analog Loop Test

The analog loop test verifies the operation of the VT22X modem communication link through the VT220 terminal, the cable connecting the VT220 terminal to the VT22X modem option, and the transmit and receive circuits in the VT22X modem option.

NOTE

Before you run the analog loop test, make sure the terminal is on-line and

EIA Port, Modem Control

is selected in the Communications Set-Up screen.

1. Press the **ANALOG LOOP** pushbutton in.
2. Verify that the **TEST** indicator is on and the modem is connected in a loop.

NOTE

To verify the connection, enter set-up and check the status line (the bottom line of the Set-Up Directory screen). If the connection was made, the right side of the status line will read

Modem: DSR, Connected

3. Type a message on the keyboard. The data you type is looped back by the modem and displayed on the terminal (Figure 1-4). This lets you compare the received data with the transmitted data for accuracy.
4. If the test fails, go to the EIA host port loopback test in Paragraph 1.4. This test helps you isolate a fault to either the VT220 terminal, or to the connecting cable and VT22X modem. If the analog loop test is successful, go to the remote loop test in Paragraph 1.9.2 to further isolate the fault.

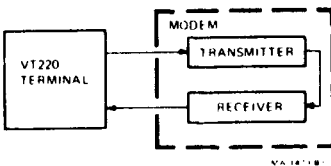

Figure 1-4 Analog Loop Test

1.9.2 Remote Loop Test

This test lets you test the communication link with a remote modem. You must run the analog loop test (Paragraph 1.9.1) successfully before you run this test.

Perform the remote loop test for both modems in a communications link. Each remote loop test is run individually. You cannot run these tests at the same time.

After you make a connection with a remote modem (another VT22X, a Digital DF03, or an AT&T 212A with the Response to Digital Loop option enabled), pressing the **REMOTE LOOP** pushbutton on the *local* VT22X modem sends a signal that places the *remote* modem in a loopback state. The **TEST** indicator on the local modem will turn on. At this point, any data typed on the local VT220 keyboard is sent to the remote modem and looped back (Figure 1-5). Then you can check the data for accuracy. Run the remote loop test as follows.

1. Verify that the **ANALOG LOOP** pushbutton and the **REMOTE LOOP** pushbutton are out.
2. Verify that the **TEST** indicator is off.
3. Put the VT22X modem in talk mode.

NOTE

To verify that the VT22X modem is in talk mode, enter set-up and check the status line (the bottom line of the Set-Up Directory screen). The right side of the status line should read

Modem: No DSR, Talk

If it reads

Modem: No DSR, Data

take these steps. Hold the **Ctrl** key and press **Data/Talk** to put the VT22X modem in talk mode. Then exit set-up.

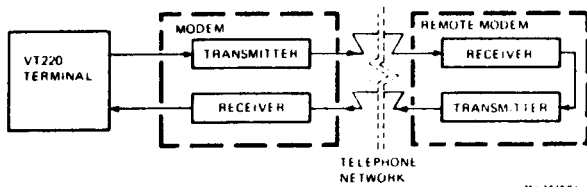

Figure 1-5 Remote Loop Test

4. Pick up the telephone and listen for the dial tone. Then dial the location you want to communicate with.

NOTE

The right side of the status line must read

Modem: No DSR, Talk

before the dial tone on your telephone can be heard.

If a person answers your call, have the modem at the remote site set to receive data. The modem then generates an answer tone.

5. When you hear the answer tone, press **Data/Talk** to put the VT22X modem in data mode. Then hang up the telephone.
6. Wait for the connection. Then press the **REMOTE LOOP** pushbutton in.

NOTE

To verify the connection, enter set-up and check the status line (the bottom line of the Set-Up Directory screen). If the connection was made, the right side of the status line will read

Modem: DSR, Connected

After the connection is made, exit set-up.

7. Verify that the TEST indicator is on.
8. Type a message on your keyboard. The data you type is sent to the remote modem. Then the data is looped back from the remote modem and displayed on your terminal (Figure 1-5). You can compare the received data with the transmitted data for accuracy.

To test the remote side of the link, put the local VT22X modem in data mode and have the remote end perform steps 1 through 8.

1.10 PRINTER PROBLEMS

If the printer does not print, perform the following steps to isolate the problem to the printer or to the video terminal.

1. Perform the power-up self-test (Paragraph 1.3). If the terminal passes the self-test, go to step 2.
2. Perform the printer port external loopback self-test (Paragraph 1.5). If your terminal passes this test, go to step 3.

NOTE

If your terminal passes the above tests, it is running correctly; the problem is not a malfunctioning terminal.

3. Test the printer. (See your printer pocket service guide for the correct procedure.) If your printer is operating, go to step 4.
4. Check the following set-up features to make sure that your VT220 terminal and printer are compatible.
 - Baud rate (VT220 and printer)
 - Data bits per character (VT220 and printer)
 - Parity (VT220 and printer)
 - **Printer Ready** must appear on the VT220 set-up status line.
 - Printer must be set to **Full Duplex** in set-up.
5. Check for the correct cable between your terminal and the printer (Appendix C). Make sure the connectors are securely fastened at both ends of the cable.
6. Put your terminal in local and in VT100 mode. Then exit set-up. Type the following sequence.

ESC # 8

Your video screen should display a test pattern of uppercase E's.

7. Press the **Print Screen** key. The video display should print out if the printer is operating correctly.

1.11 SELF-TEST ERROR CODES

If your screen displays an error message, refer to Table 1-2. Each error message includes the FRU you must replace to correct the problem.

If a video problem occurs, refer to Table 1-3 for error codes shown by the LED indicators (Figure 1-1). The LED indicators always display the error code for the test currently running. This test must run successfully before your VT220 terminal clears the error readout.

Refer to Table 1-4 for other troubleshooting procedures.

Table 1-2 VT220 Monitor Display Error Codes

Error Message	Corrective Action
VT220 NVR Error - 1	<ol style="list-style-type: none"> 1. Enter set-up. 2. Check default values. 3. Power down, then power up. 4. If error continues, replace terminal controller board.
VT220 EIA Port Data Error - 2	Replace terminal controller board.
VT220 EIA Port Controls Error - 3	Replace terminal controller board.
VT220 Keyboard Error - 4	<ol style="list-style-type: none"> 1. Check to see if keyboard is plugged in. 2. Replace keyboard. 3. Replace terminal controller board. 4. Replace power supply/monitor board.
VT220 20 mA Port Error - 5	<ol style="list-style-type: none"> 1. Replace terminal controller board. 2. Replace power supply/monitor board.
VT220 Printer Port Error - 6	<ol style="list-style-type: none"> 1. Replace terminal controller board. 2. Replace power supply/monitor board.

NOTE

Keyboard LED indicators flash repeatedly: on for one second, off for one-third of a second, in the following patterns.

Table 1-3 VT220 LED Error Codes

L1 Hold	L2 Lock	L3 Compose	L4 Wait	Replace	
○	○	○	○	Controller (Para. 2.3)	
○	○	○	●	↓	
○	○	●	○		
○	○	●	●		
●	○	○	○		
●	○	○	●		
●	○	●	○		
●	○	●	●		
●	●	○	○		
●	●	○	●		
●	●	●	○		
●	●	●	●		
x	x	x	x		Keyboard (Para. 2.7)

- = on
 ○ = off
 x = varying LED display that repeats one of the above patterns

1.12 TROUBLESHOOTING GENERAL PROBLEMS

Table 1-4 lists some common problem symptoms and their probable causes, and suggests corrective actions.

Table I-4 VT220 Troubleshooting Chart

Symptom	Probable Cause	Corrective Action
No VT220 OK display, power OK indicator off, no bell tone.	Not plugged in, or no power at wall outlet.	Plug in VT220, or try another wall outlet.
	Power fuse	Replace fuse.
	AC power cord	Check for opens/shorts.
	Power supply	Replace power supply/monitor board.
No VT220 OK display, power OK indicator on, no bell tone.	Terminal controller board	Replace terminal controller board.
No VT220 OK display, power OK indicator on, bell tone present.	Brightness set too low.	Adjust contrast and brightness controls.
	Terminal controller board	Replace terminal controller board.
	Monitor board	Replace power supply/monitor board.
	Flyback transformer	Replace flyback transformer.
	CRT and yoke	Replace the VT200 terminal.
VT220 OK display present, power OK indicator on, bell tone present VT220 cannot communicate with host.	VT220 to host port connection loose.	Check to see if host plugged in.
	Host port circuits faulty	Run EIA or 20 mA loopback test.
	Terminal controller to power supply/monitor board connection.	Check terminal controller to power supply/monitor board connector.
Random characters appear on screen.	Terminal controller board	Replace terminal controller board.

Table 1-4 VT220 Troubleshooting Chart (Cont)

Symptom	Probable Cause	Corrective Action
Horizontal or vertical line appears on screen.	Monitor connectors	Check and reconnect.
	Monitor circuit	Replace power supply/monitor board.
	CRT and yoke	Replace the VT220 terminal.
Screen display distorted.	Monitor is out of alignment.	Align monitor.
	Monitor circuit	Replace power supply/monitor board.
	Terminal controller board	Replace terminal controller board.
	CRT and yoke	Replace the VT220 terminal.
Screen display jittery.	Flyback transformer	Replace flyback transformer.
No bell tone.	Keyboard speaker faulty.	Replace keyboard.
Different characters appear on screen than were typed in local.	Alternate character set selected.	Clear with <code>Reset</code> field in set-up.
	Keyboard	Replace keyboard.
	Terminal controller board	Replace terminal controller board.
Different characters appear on screen than were typed while on-line with host. (Terminal works in local.)	Transmit and receive speeds are set wrong.	Set speeds to match host.
	Bits per character is set wrong.	Set bits to match host.
	Parity is set wrong.	Set parity to match host.
	Stop bits is set wrong.	Set to match host.

Table I-4 VT220 Troubleshooting Chart (Cont)

Symptom	Probable Cause	Corrective Action
Terminal display does not scroll, Hold Screen indicator on.	Hold screen mode enabled.	Press the Hold Screen key to disable.
Terminal appears locked, does not respond to data from host.		Clear terminal with Clear Comm field in set-up. Turn ac power off, then on again.
Screen goes blank after successful power-up, then is inactive for one-half hour. Power OK indicator on.	CRT saver feature on.	Press any key to reactivate screen.
Messages are incomplete.	XON/XOFF not selected.	Enable in set-up.
	Terminal controller board	Replace terminal controller board.
	Host port connections.	Check host ports.
Terminal does not respond to escape sequences.	Incorrect mode selected.	Select VT100 mode in set-up.

2 REMOVING AND REPLACING FRUs (MODELS A, B, AND C)

2.1 GENERAL

This chapter shows you how to remove and replace FRUs for VT220 models A, B, and C. Some procedures also apply to models D, E, and F. Chapter 3 lists the procedures that are different for models D, E, and F.

The following procedures apply to all VT220 terminals.

Access cover	Para. 2.2
Keyboard*	Para. 2.7
VT2XX modem	Para. 2.8

To identify the model you are servicing, check the model number on the rear of the terminal (Figure 2-1).

Paragraph 2.9 provides the recommended spares list for models A, B, and C.

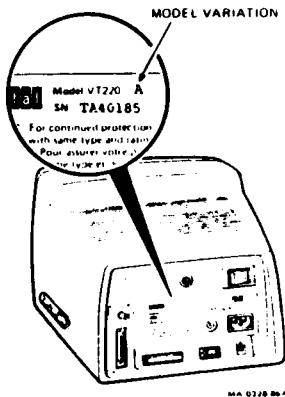

Figure 2-1 Identifying the VT220 Model

* See note at Paragraph 3.7.

2.2 ACCESS COVER (ALL MODELS)

Remove the terminal access cover as follows.

1. Turn the power to the terminal off.
2. Disconnect the power cord from the wall outlet. Remove the power cord from the terminal's power cord connector.
3. Disconnect the keyboard cable connector and the connector from the video output jack, if applicable.
4. Disconnect all other cables from the rear panel of your terminal, including the following.
 - EIA host port cable
 - 20 mA host port cable
 - printer port cable

NOTE

Before you go to step 5, place a piece of paper on a flat work surface to avoid scratching the monitor bezel. Carefully place the monitor face down on this paper.

You must clean the face of the CRT after you service the monitor. Use the cleaning solution supplied with the monitor or use isopropyl alcohol.

22 REMOVING/REPLACING FRUs (MODELS A B, C)

5. With a scribe, remove the plastic cap on the rear panel of the access cover.

REMOVE THE
PLASTIC CAPS (3)

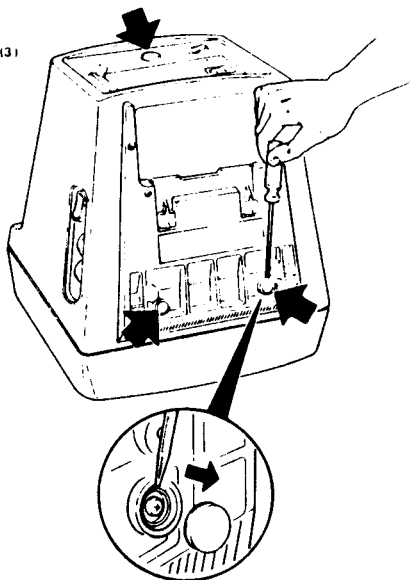

MA 0246 R 2P

6. With a phillips screwdriver, remove the screw and washer that were exposed when you removed the cap. This screw helps hold the access cover to the terminal's chassis.
7. With the scribe, remove the two caps on the bottom side of the access cover.
8. Remove the screws and washers that were exposed when you removed these caps.

REMOVE THE PHILLIPS SCREWS (3)
AND WASHERS (3)

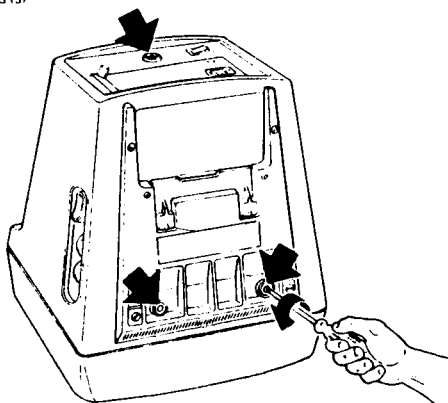

MA 0846 BJA

WARNING

The next step exposes you to the CRT anode, which may contain a stored high voltage. Use caution while the access cover is off the terminal.

9. Remove the access cover by sliding it straight up.

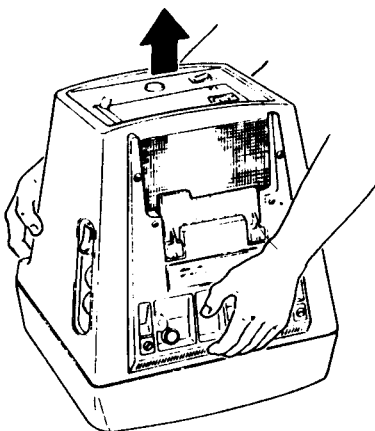

MA 0847 8J

To install the access cover, reverse steps 1 through 9.

CAUTION

During installation, the access cover may require careful positioning to align the screw holes.

2.3 TERMINAL CONTROLLER BOARD

Remove the terminal controller board as follows.

1. Remove the access cover (Paragraph 2.2).
2. Disconnect the flat cable going to the power supply/monitor board.
3. Loosen the knurled captive grounding screw on the terminal controller board until it is held only by its retaining spring.
4. Free the controller board from the three standoff fasteners by simultaneously lifting the board and squeezing each standoff fastener with needlenose pliers.

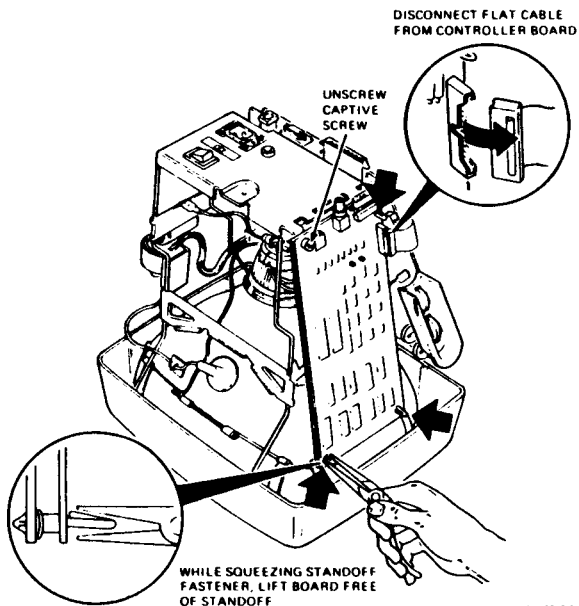

To install the terminal controller board, reverse steps 1 through 4.

NOTE

When replacing the terminal controller board, you should also replace the three standoffs used to mount the board to the chassis. New standoffs come with each controller board.

2.4 POWER SUPPLY/MONITOR BOARD

Remove the power supply/monitor board as follows.

WARNING

This procedure exposes you to the high voltage of the CRT and the power supply. Use caution while the access cover is off the terminal.

1. Remove the access cover (Paragraph 2.2).
2. Disconnect the 26-pin flat cable connector from the terminal controller board.
3. Disconnect the following cables in order from the power supply/monitor board.
 - a. The 2-wire cable that runs to the power OK indicator on the front bezel

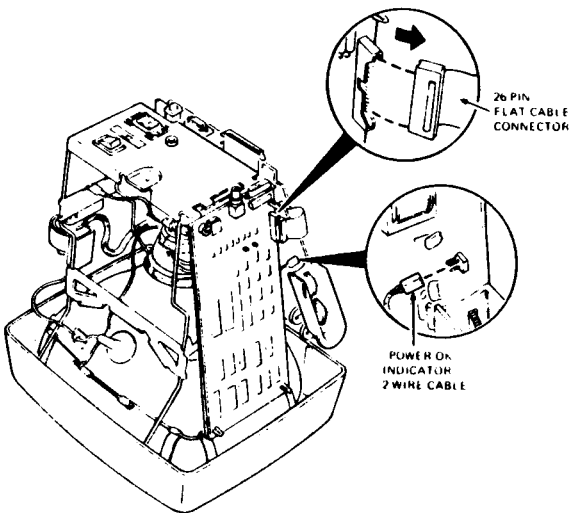

- b. The 6-wire input cable that runs to the rear chassis panel
- c. The 7-wire cable that runs to the flyback transformer

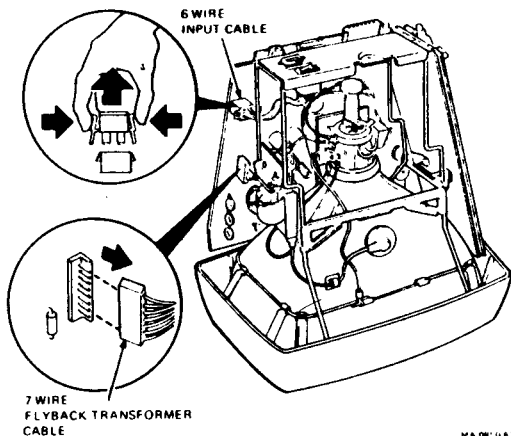

28 REMOVING/REPLACING FRUs (MODELS A, B, C)

4. Remove the white ground wire from the tab on the CRT ground loop clamp. This wire runs to the round CRT connector.
5. Remove the round CRT connector from the base of the CRT.

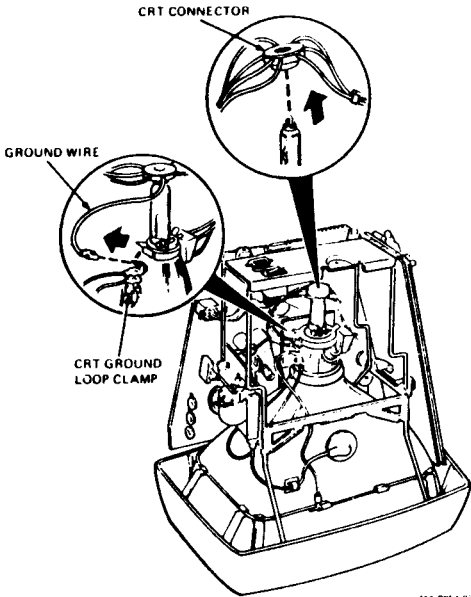

6. Remove the four phillips screws on the power supply/monitor board that hold the board to the chassis.

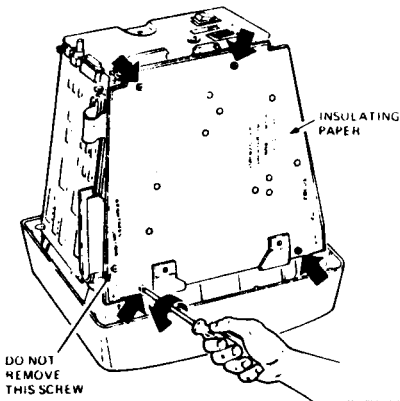

7. Cautiously move the power supply/monitor board away from the chassis so you can see the remaining connectors.
8. Untwist the white plastic clamp that holds the CRT round connector cable to the chassis.
9. Disconnect the 4-wire cable that runs to the yoke of the CRT to free the power supply/monitor board.

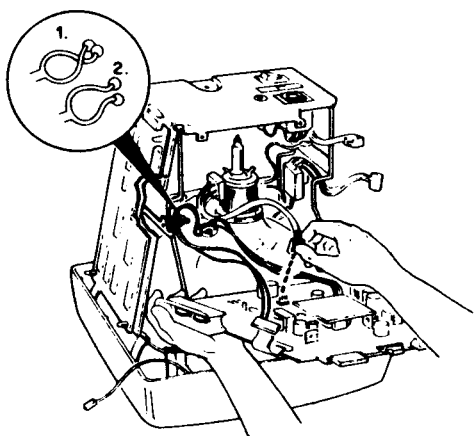

MA 081,303

To install the power supply/monitor board, reverse steps 1 through 11.

NOTE

Make sure you can reach the CRT round connector cable to install it after you secure the power supply/monitor board to the chassis with screws. When replacing the CRT round connector, make sure it is seated firmly on the neck of the CRT.

CAUTION

To protect the components on the power supply/monitor board from short circuiting, make sure you reinstall the insulating paper.

2.5 FLYBACK TRANSFORMER

Remove the flyback transformer as follows.

1. Remove the access cover (Paragraph 2.2).

WARNING

The following step exposes you to the CRT anode, which may contain a stored high voltage.

2. Discharge the CRT anode by performing the following steps.
 - a. Attach the clip end of the anode discharge tool (PN 29-24717-00) to the metal chassis.
 - b. Push the probe end under the soft plastic anode connector cap until you feel the probe touching the anode connector.

CAUTION

Do not scratch the glass of the CRT when discharging the anode.

- c. Hold the probe against the anode connector for at least 3 seconds, then remove the probe.

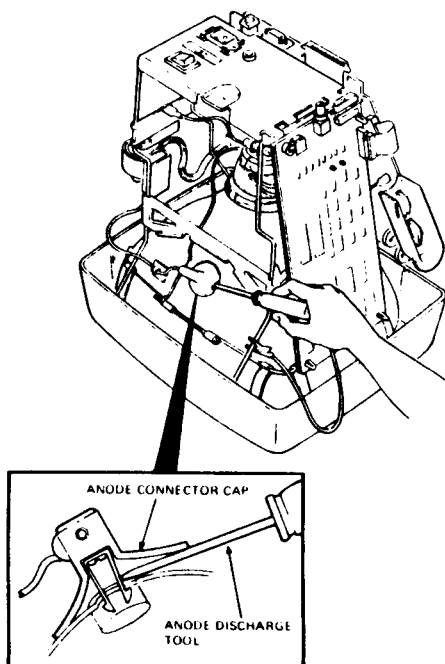

3. Cut the tie wrap that holds the CRT anode wire to the CRT.

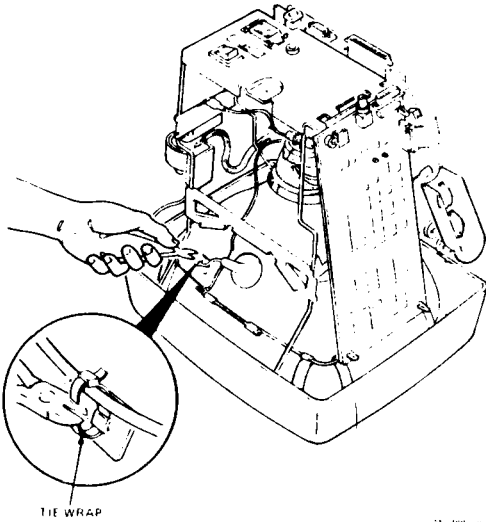

32 REMOVING/REPLACING FRUs (MODELS A, B, C)

4. Remove the CRT anode connector from the CRT.

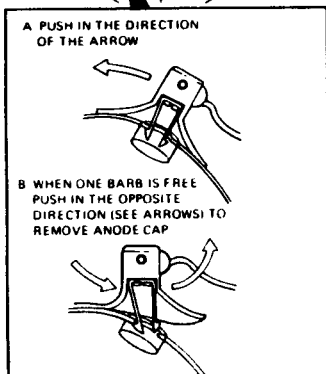
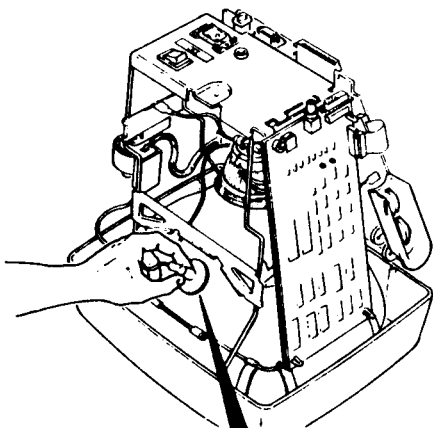

5. Disconnect the 7-wire connector from the power supply/monitor board.

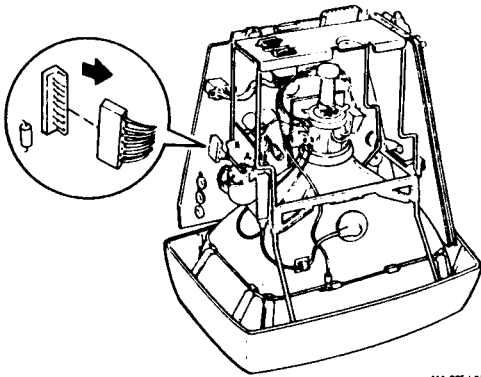

MA 085 / 83

6. Use a 1/4-inch nut driver to remove the two nuts and two washers that hold the flyback transformer to the chassis. Remove the flyback transformer.

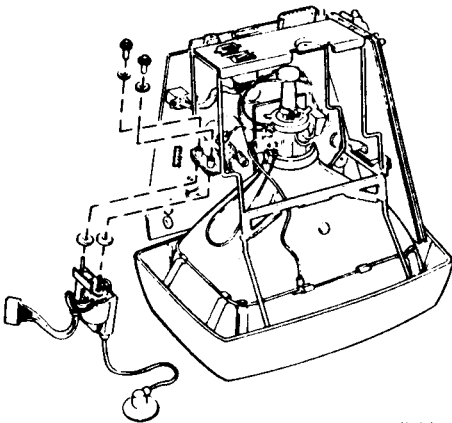

MA 085B / 83

To install the flyback transformer, reverse steps 1 through 6.

CAUTION

Do not forget to replace the tie wrap that holds the anode wire to the CRT.

2.6 CRT ASSEMBLY

If you cannot repair the VT220 monitor with the video alignment and adjustment procedures (Chapter 4) replace the complete VT220 terminal (whole option swap). Do not try to remove or repair any part of the CRT assembly in the field.

Remove the terminal as follows.

1. Set the power switch to 0 (off position) before disconnecting cables from the rear panel of your terminal.

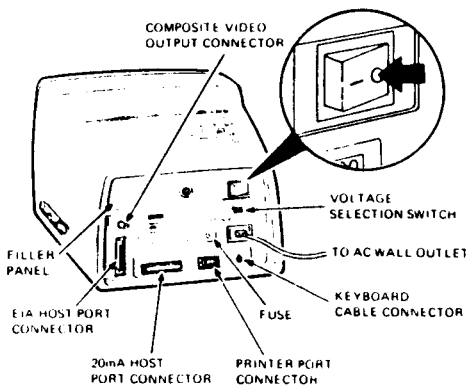

MA 0966 24

2. Disconnect the following cables from the rear panel of your terminal, if applicable.
 - AC power cord
 - EIA host port cable
 - 20 mA host port cable
 - composite video output cable
 - video monitor cable
 - printer cable
 - keyboard cable

To install your new VT220 terminal, reverse steps 1 and 2.

2.7 KEYBOARD (ALL MODELS)*

If the keyboard is faulty, replace the entire keyboard (whole option swap). Remove the keyboard as follows.

1. Disconnect the keyboard cable from the cable connector on the rear panel of your VT220.
2. Remove the keyboard cable from the keyboard.

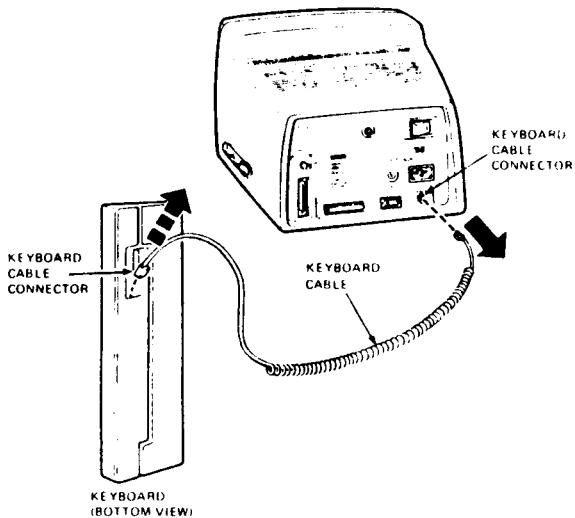

Perform the following steps to install the new keyboard.

Install the Legend Strip

1. Open the clear plastic window.

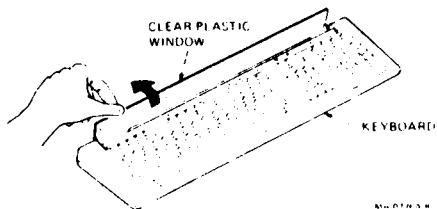

* See note at Paragraph 3.7.

36 REMOVING/REPLACING FRUs (MODELS A, B, C)

2. Remove the legend strip from the defective keyboard.
3. Insert the old legend strip directly over the one already on the new keyboard.

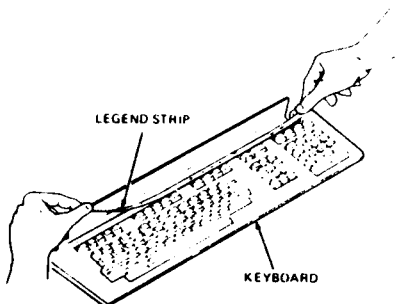

MA 0777A 01

4. Close the clear plastic window.

Install the Keyboard Standoffs

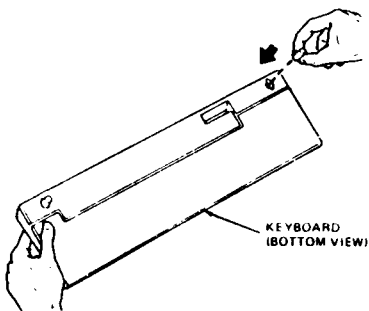

MA 0778A 01

Connect the Keyboard to the Video Terminal

1. Turn the terminal power switch off.
2. Insert the longer end of the keyboard cable into the connector on the bottom of the keyboard.
3. Press the cable into the long groove if routing to the left.
4. Press the cable into the short groove if routing to the right.
5. Insert the keyboard cable into the connector on the rear of the terminal.

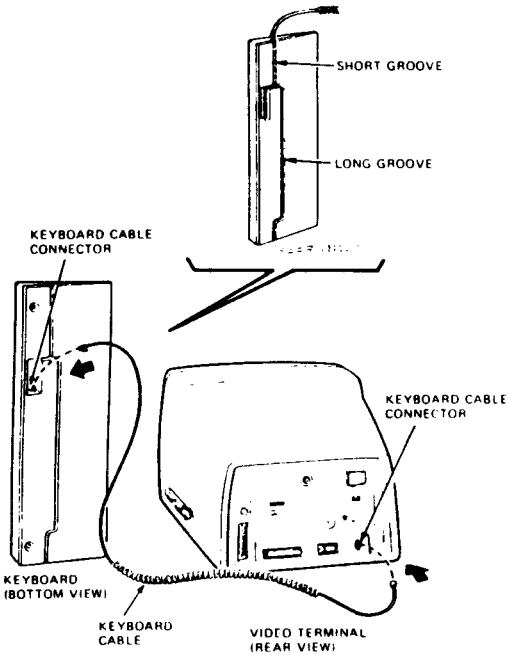

2.8 VT22X MODEM OPTION (ALL MODELS)

The VT22X modem consists of three FRUs: the VT22X modem, the EIA cable with shorting plug, and the telephone cable.

2.8.1 Installing the VT22X Modem

Install a VT22X modem as follows.

1. Turn the terminal switch power off.
2. Disconnect these cables (if connected).
 - power cable
 - keyboard cable
 - EIA communications
 - 20 mA port cable
 - printer port cable
 - video output cable
3. Lay the terminal on a flat surface (bottom side up).

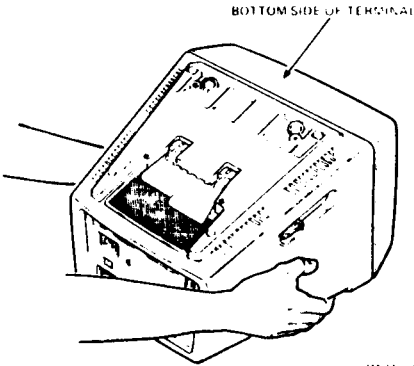

4. Identify the modem mounting holes.

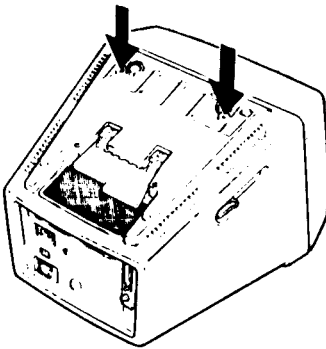

5. Align the mounting holes in the modem and terminal.

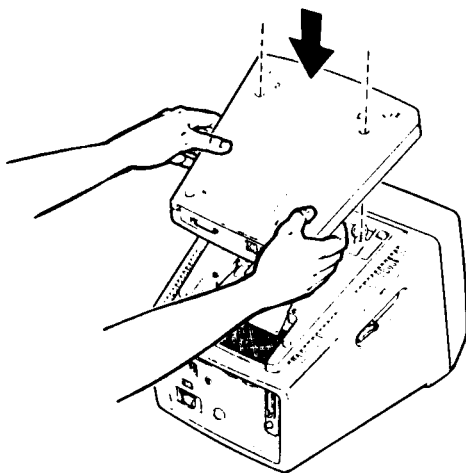

6. Attach the modem to the terminal with the screwdriver and screws provided.

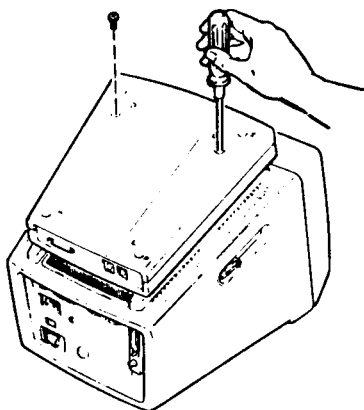

To remove the modem, perform steps 1 through 3. Then remove the screws holding the modem to the terminal.

2.8.2 Installing the VT22X Modem Cabling

Install the EIA cable with shorting plug (PN 70-21475-01) and the telephone cable (PN 17-00089-01) as follows.

1. Turn the terminal and modem upright as shown.

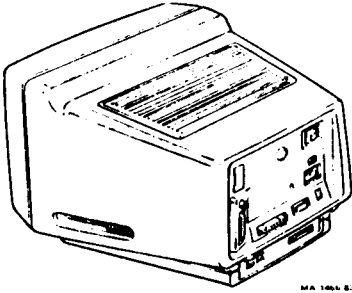

2. Locate the EIA cable and shorting plug.

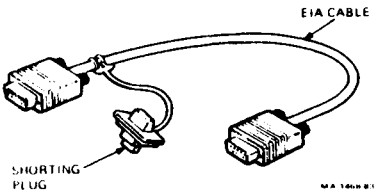

3. Identify the connectors on the rear panel of the modem and terminal.

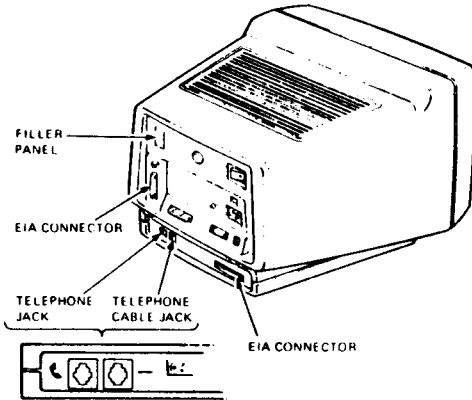

MA 1467 R1

4. Remove the filler panel on the terminal.

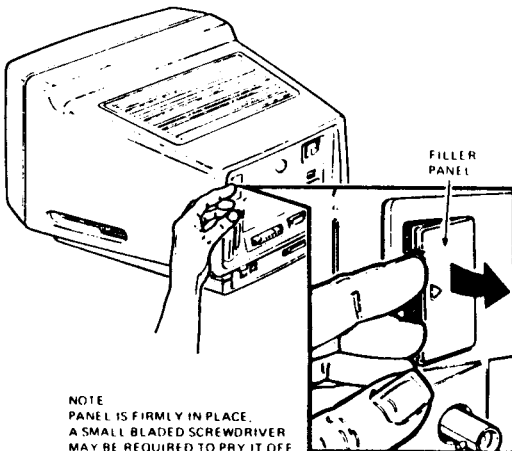

NOTE
PANEL IS FIRMLY IN PLACE.
A SMALL BLADED SCREWDRIVER
MAY BE REQUIRED TO PRY IT OFF

MA 1467 R1

42 REMOVING/REPLACING FRUs (MODELS A, B, C)

5. Connect the EIA cable and shorting plug as shown.

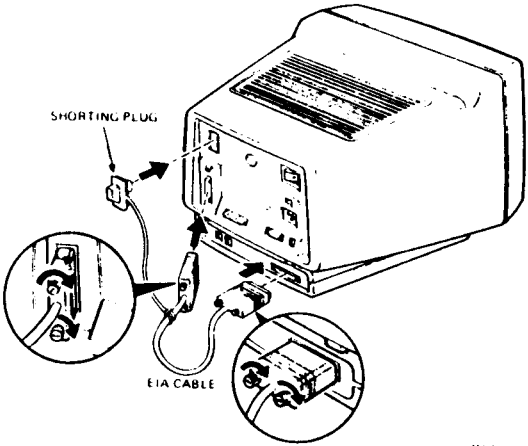

MA 14 11 P

6. Connect the telephone to the modem.
7. Connect the telephone cable to the modem and RJ11C wall jack.

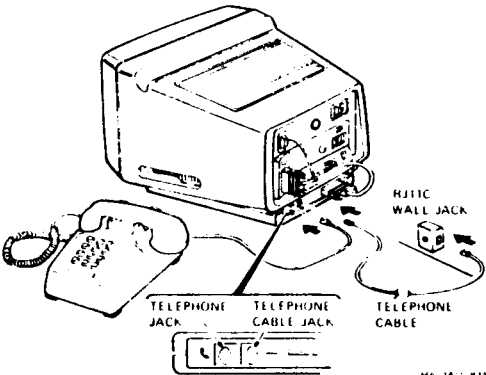

MA 14 11 B3A

To remove the EIA cable, reverse step 5. To remove the telephone cable, reverse step 7.

2.9 RECOMMENDED SPARES LIST (MODELS A, B, AND C)

Table 2-1 lists the recommended spares for VT220 models A, B, and C. Refer to Table 3-1 for models D, E, and F.

Table 2-1 Recommended Spares List (Models A, B, and C)

Description	Part Number
Terminal controller	70-20814-02
Power supply/monitor board	70-20624-01
Flyback transformer	70-20772-01
CRT/bezel/yoke (white)	70-20622-04
(green)	70-20622-05
(amber)	70-20622-06
VT22X modem (with EIA cable and telephone cable)	70-21205-01
EIA cable with shorting plug (modem cable)	70-21475-01
Telephone cable	17-00089-01
EIA loopback connector	12-15336-00
20 mA loopback connector	70-15503-00
Printer port loopback	29-24794-00
United States keyboard	LK201-AA
French Canadian keyboard	LK201-AC
Danish keyboard	LK201-AD*
British keyboard	LK201-AE*
Finnish keyboard	LK201-AF
Austrian/German keyboard	LK201-AG
Dutch keyboard	LK201-AH
Italian keyboard	LK201-AI
Swiss (French) keyboard	LK201-AK
Swiss (German) keyboard	LK201-AL
Swedish keyboard	LK201-AM
Norwegian keyboard	LK201-AN
French/Belgium keyboard	LK201-AP
Spanish keyboard	LK201-AS
Australian keyboard	LK201-AZ
Keycap removal tool	74-27314-01
Video alignment tool	29-23190-00
Tuning wand	29-23189-00
Fuse (U.S.), 2 amps	90-07215-00
Fuse carrier (U.S.)	12-21126-03
Fuse holder	12-21126-01
Fuse (European), 2 amps	12-19285-03
Fuse carrier (European)	12-21126-04
Tie wraps	90-09996-00

* Do not use with VT220 models D, E, and F.
See Table 3-1.

3 REMOVING AND REPLACING FRUs (MODELS D, E, AND F)

3.1 GENERAL

This chapter shows you how to remove and replace FRUs for VT220 models D, E, and F. Some of the procedures are the same as for models A, B, and C. Chapter 2 contains the procedures that are the same.

Access cover	Para. 2.2
Keyboard*	Para. 2.7
VT2XX modem	Para. 2.8

To identify the model you are servicing, check the model number on the rear of the terminal (Figure 3-1). For models A, B, and C, refer to Chapter 2.

Paragraph 3.9 provides the recommended spares list for models D, E, and F.

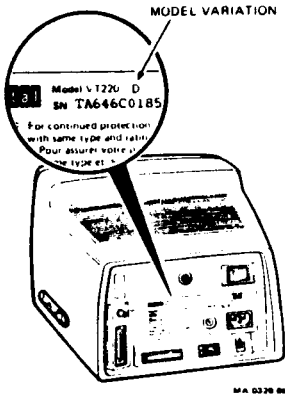

Figure 3-1 Identifying the VT220 Model

* See note at Paragraph 3.7.

3.2 ACCESS COVER

Refer to Paragraph 2.2.

3.3 TERMINAL CONTROLLER BOARD

Remove the terminal controller board as follows.

1. Remove the access cover (Paragraph 2.2).
2. Disconnect the flat cable that goes to the power supply/monitor board.
3. Loosen the four phillips screws from the terminal controller board.
4. Lift the board to release it from the slotted brackets and remove.

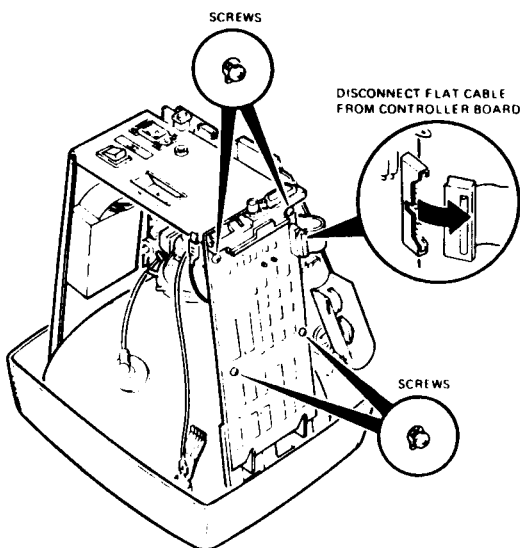

M.A. 0246 B1

To install the terminal controller board, reverse steps 1 through 4.

3.4 POWER SUPPLY/MONITOR BOARD

Remove the power supply/monitor board as follows.

WARNING

This procedure exposes you to the high voltage of the CRT and the power supply.

1. Remove the access cover (Paragraph 2.2).

WARNING

The following step exposes you to the CRT anode, which may contain a stored high voltage.

2. Discharge the CRT anode by performing the following steps.
 - a. Attach the clip end of the anode discharge tool (PN 29-24717-00) to the metal chassis.
 - b. Push the probe end under the soft plastic anode connector cap, until you feel the probe touching the anode connector.

CAUTION

Do not scratch the glass of the CRT when discharging the anode.

- c. Hold the probe against the anode connector for at least 3 seconds, then remove the probe.

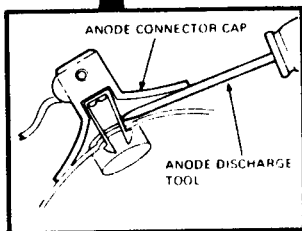
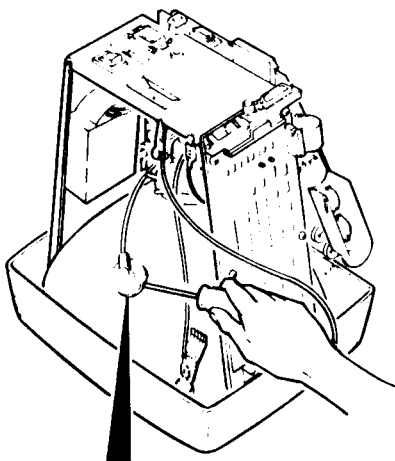

MA 019 6

3. Remove the anode from the CRT.

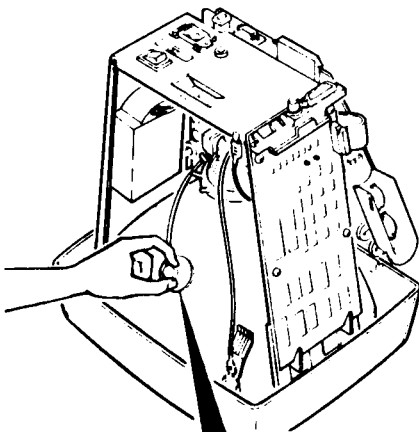

A PUSH IN THE DIRECTION OF THE ARROW

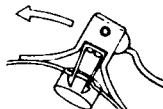

B WHEN ONE BARB IS FREE PUSH IN THE OPPOSITE DIRECTION (SEE ARROWS) TO REMOVE ANODE CAP

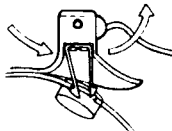

4. Disconnect the CRT connector from the CRT neck. Push the connector so that it rests between the power supply/monitor board and the CRT neck.
5. Disconnect the ground wire from the ground clip on the CRT. This wire runs to the CRT connector. Disconnect the white ground wire from the chassis. This wire runs to the power supply/monitor board.

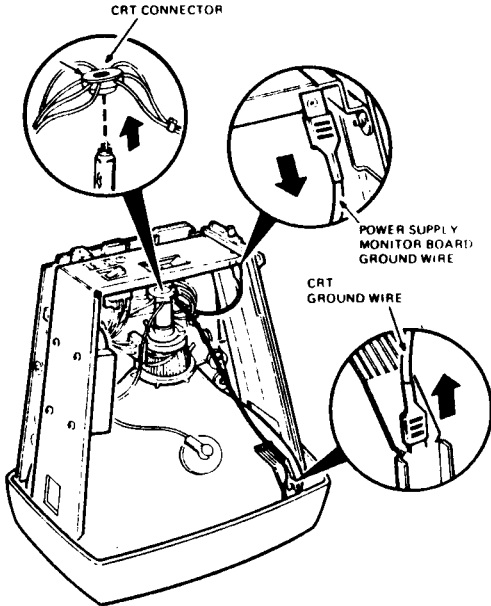

50 REMOVING/REPLACING FRUs (MODELS D, E, F)

6. Disconnect the 26-pin flat cable connector from the terminal controller board.
7. Disconnect the 2-wire cable that runs to the power OK indicator on the front bezel (J7).
8. Use a phillips screwdriver to loosen the two screws from the top of the board. The screws are in keyholes.

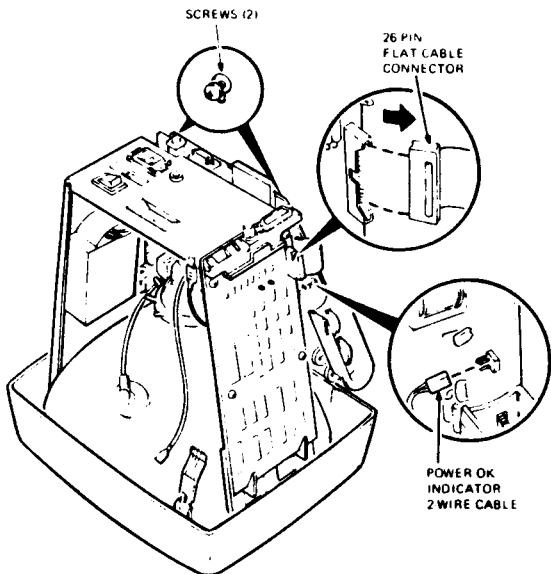

9. Pull the board up and forward to disconnect the following cables.
 - a. The 2-wire cable that runs to the transformer
 - b. The 4-wire cable that runs from J1 to the deflection yoke (J1)

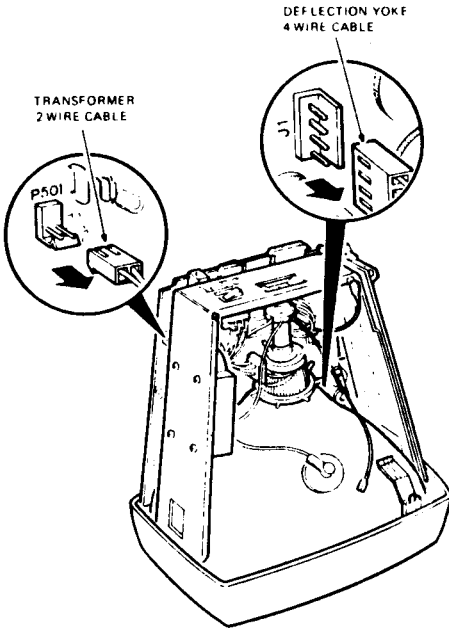

To install the power supply/monitor board, reverse steps 1 through 9.

3.5 TRANSFORMER

Remove the transformer as follows.

1. Remove the access cover (Paragraph 2.2).

WARNING

The following step exposes you to the CRT anode, which may contain a stored high voltage.

2. Discharge the CRT anode by performing the following steps.
 - a. Attach the clip end of the anode discharge tool (PN 29-24717-00) to the metal chassis.
 - b. Push the probe end under the soft plastic anode connector cap, until you feel the probe touching the anode connector.

CAUTION

Do not scratch the glass of the CRT when discharging the anode.

- c. Hold the probe against the anode connector for at least 3 seconds, then remove the probe.

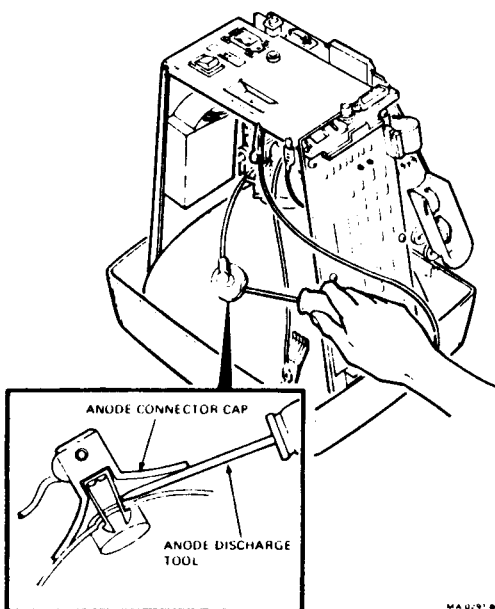

3. Disconnect the 2-wire cable from the power supply/monitor board.
4. Turn the terminal so the transformer is on your left. Use a flat blade screwdriver to pry off the right rear plug from the power I/O switch. (This transformer wire branches between the voltage select switch and the power I/O switch.)

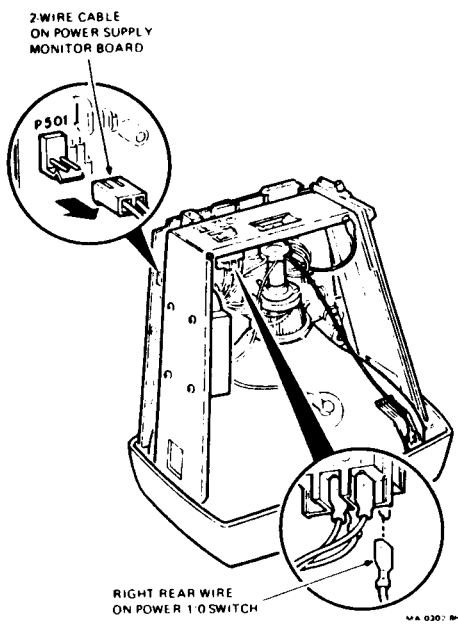

54 REMOVING/REPLACING FRUs (MODELS D, E, F)

5. Pry off the four connectors from the back of the voltage select switch.
6. Disconnect the transformer wire from the side of the fuse.

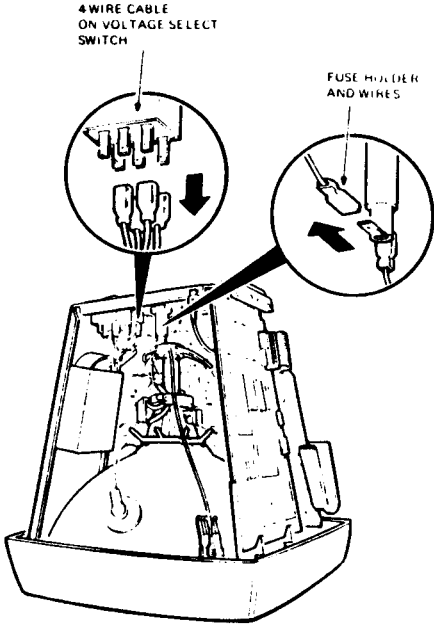

WARNING

Be careful not to drop the transformer on the CRT neck, or to hit the CRT as you remove the transformer.

7. Remove the four screws that hold the transformer to the chassis.
Hold on to the transformer to prevent it from dropping to the table as you release it.

To install the transformer, reverse steps 1 through 7.

3.6 CRT/BEZEL ASSEMBLY

The CRT/bezel assembly is one FRU. Do not try to remove or repair any part of this assembly in the field. To replace the assembly, remove and save the following FRUs.

1. Remove the access cover (Paragraph 2.2).
2. Remove the terminal controller board (Paragraph 3.3).
3. Remove the power supply/monitor board (Paragraph 3.4).
4. Remove the transformer (Paragraph 3.5).

To install a new CRT/bezel assembly, reverse steps 1 through 4. Place a piece of paper on a flat working surface. Carefully place the new monitor face down on the paper. The paper prevents scratches to the monitor bezel.

3.7 KEYBOARD

Refer to Paragraph 2.7.

NOTE

There are two versions of United Kingdom, Danish, and Norwegian keyboards. You must use the correct version of the United Kingdom and Danish keyboards. See Tables 2-1 and 3-1 for part numbers.

3.8 VT22X MODEM OPTION

Refer to Paragraph 2.8.

3.9 RECOMMENDED SPARES LIST (MODELS D, E, and F)

Table 3-1 lists the recommended spares for VT220 models D, E, and F. Refer to Table 2-1 for models A, B, and C.

Table 3-1 Recommended Spares List (Models D, E, and F)

Item	Part Number
Terminal controller	70-23363-01
Power supply/monitor board	70-23361-01
Transformer	70-23362-01
CRT/bezel/yoke (white)	70-23360-01
(green)	70-23360-02
(amber)	70-23360-03
VT22X modem (with EIA cable and telephone cable)	70-21205-01
EIA cable with shorting plug (modem cable)	70-21475-01
Telephone cable	17-00089-01
EIA loopback connector	12-15336-00
20 mA loopback connector	70-15503-00
Printer port loopback	29-24794-00
United States keyboard	LK201-AA
French Canadian keyboard	LK201-AC
Danish keyboard	LK201-ED*
British keyboard	LK201-EE*
Finnish keyboard	LK201-AF
Austrian/German keyboard	LK201-AG
Dutch keyboard	LK201-AH
Italian keyboard	LK201-AI
Swiss (French) keyboard	LK201-AK
Swiss (German) keyboard	LK201-AL
Swedish keyboard	LK201-AM
Norwegian keyboard	LK201-EN
French/Belgium keyboard	LK201-AP
Spanish keyboard	LK201-AS
Australian keyboard	LK201-AZ
Video alignment tool	29-23190-00
Tuning wand	29-23189-00
Fuse (U.S.), 2 amps	90-07215-00
Fuse carrier (U.S.)	12-21126-03
Fuse holder	12-21126-01
Fuse (European), 2 amps	12-19285-03
Fuse carrier (European)	12-21126-04
Tie wraps	90-09996-00

* Do not use with VT220 models A, B, and C.
See Table 2-1.

4 VIDEO MONITOR ALIGNMENT

4.1 GENERAL

This chapter shows you how to align the VT220 monitor. You do not have to make every adjustment each time you align your monitor. However, you should check all adjustments, because many adjustments affect the other settings. If you find a correct setting, you can skip that adjustment and go on to check the next setting.

You must make all adjustments under the following conditions.

Enter set-up and select the following.

- Reverse video mode (black characters on a white background)
- 80 columns per line
- VT100 mode
- Local

Use a flexible metric ruler for determining alignment adjustments. Make sure all adjustments are made under the above conditions.

4.2 MONITOR ADJUSTMENTS

Figure 4-1 shows the locations for most of the adjustments.

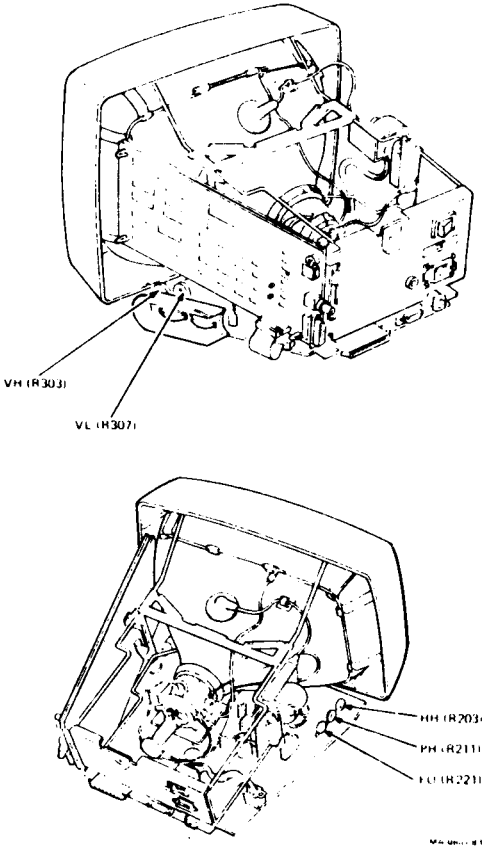

Figure 4-1a Video Adjustment Locations (Models A, B, and C)

4.2.1 Initial Preparations

Before you perform adjustments, complete the following steps.

1. Remove the access cover (Paragraph 2.2).
2. Place your terminal as shown in Figure 4-1. Make sure your monitor is on a nonconductive surface.
3. Reconnect the keyboard cable and power cord.
4. Turn the power switch on.

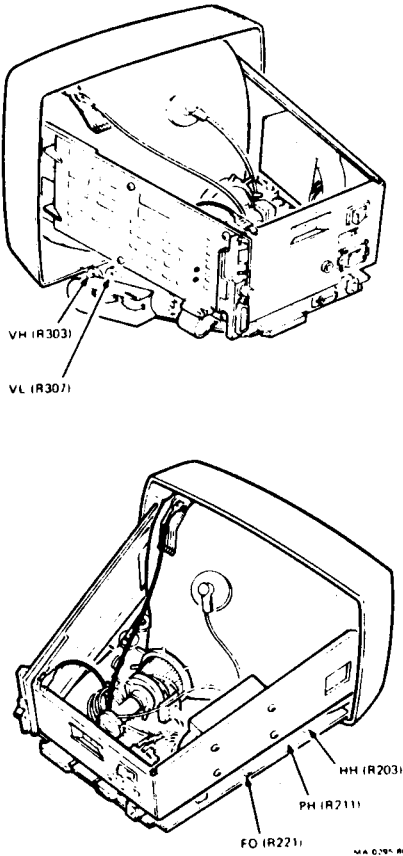

Figure 4-1b Video Adjustment Locations
(Models D, E, and F)

5. After VT220 OK appears on your screen, type ESC # 8. Your screen will display all capital E's. This is your alignment pattern.

NOTE

Your alignment pattern may not be distinct. Start with the following alignment procedures to correct the problem.

4.2.2 Character Quality

This section covers brightness, contrast, vertical linearity, and focus adjustments.

4.2.2.1 Brightness - Adjust the brightness as follows.

1. Let the terminal warm up for at least five minutes.
2. Increase the brightness and the contrast controls to maximum (Figure 4-2).
3. Decrease the brightness until the white diagonal lines (raster) just disappear.
4. Go to Paragraph 4.2.2.2.

4.2.2.2 Contrast - Set the contrast control for the desired screen intensity.

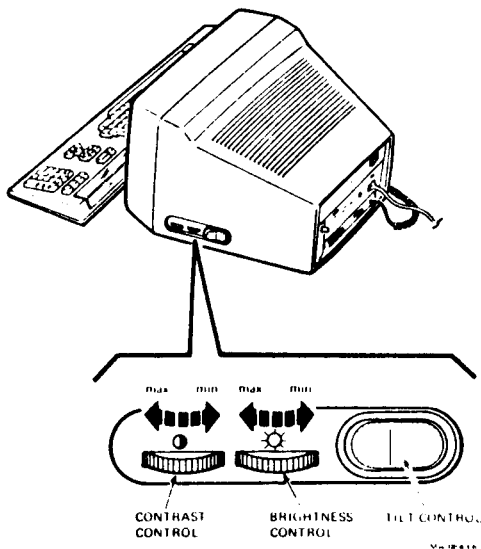

Figure 4-2 Brightness, Contrast, and Tilt Controls

4.2.2.3 Vertical Linearity – Check and adjust the vertical linearity as follows.

1. Check character heights at the four corners and center of the screen. All characters should be the same height (3.7 ± 0.4 mm).
2. If necessary, adjust the vertical linearity (VL) control (Figure 4-1) until all characters are the same height.
3. Go to Paragraph 4.2.2.4.

4.2.2.4 Focus – Check and adjust the focus as follows.

1. Check the characters at the four corners and center of the screen. You should be able to see the individual dots in the vertical segments of each E.

NOTE

Make sure the screen is clean. This condition can appear to affect the focus.

In some cases, the operator may want the focus adjusted to suit personal preference. If the focus is adjusted as desired, go to step 3.

2. Adjust the focus (FO) control (Figure 4-1) for the best overall character presentation, if necessary.
3. Go to Paragraph 4.2.3.

4.2.3 Horizontal Hold (Display Instability Adjustment)
Check and adjust the horizontal hold as follows.

1. Examine the screen for tearing or any other signs of horizontal instability.
2. If necessary, adjust the horizontal hold (HH) control (Figure 4-1) to stabilize the display.
3. Go to Paragraph 4.2.4.

NOTE

There is no vertical hold adjustment.

4.2.4 Display Centering

This section covers horizontal and vertical centering adjustments.

4.2.4.1 Horizontal Centering – Check and adjust the horizontal centering as follows. Use your flexible ruler.

1. Measure the distance between the center of the left edge of the alignment pattern of E's on the screen and the monitor bezel. Make a note of the result.
2. Measure the distance between the center of the right edge of the alignment pattern of E's and the monitor bezel. Make a note of the result.
3. Compare the measurements in steps 1 and 2. If the difference between the two measurements is greater than 6 mm, adjust the horizontal centering control (PH in Figure 4-1).
4. Perform steps 1 and 2 again to verify the adjustment.

NOTE

If the PH control adjusts the horizontal centering correctly, go to Paragraph 4.2.5.

5. Go to Paragraph 4.2.4.2.

4.2.4.2 Vertical Centering – Check and adjust the vertical centering as follows. Use your flexible ruler.

1. Measure the distance between the center character in the top row of E's and the monitor bezel. Make a note of the result.
2. Measure the distance between the center character in the bottom row of E's and the monitor bezel. Make a note of the result.
3. If the distance is less than 3 mm in either case, center the screen display by rotating the centering rings on the neck of the CRT. Use the ring tabs to rotate these rings (Figure 4-3).
4. Repeat Paragraph 4.2.4.1 to bring the horizontal centering control (PH) within range.

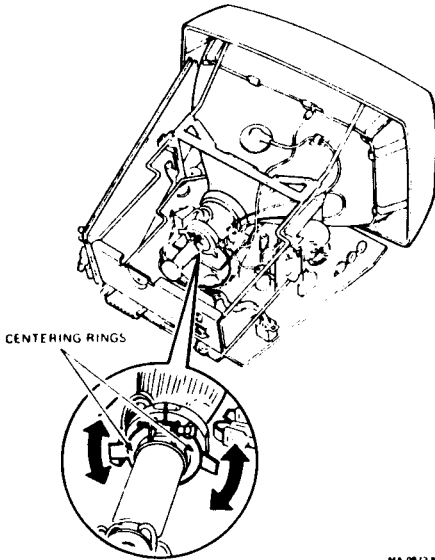

MA 087382

Figure 4-3 Centering Adjustments

4.2.5 Display Size

This section covers horizontal width and vertical height adjustments.

4.2.5.1 Horizontal Width - Check and adjust the horizontal width as follows.

Use your flexible ruler to measure the width of one row in the alignment pattern of E's. If the row does not measure 203.2 mm, adjust the horizontal width (HW) control (L201 in Figure 4-4) with the tuning wand tool (PN 29-23189-00). Go to Paragraph 4.2.5.2.

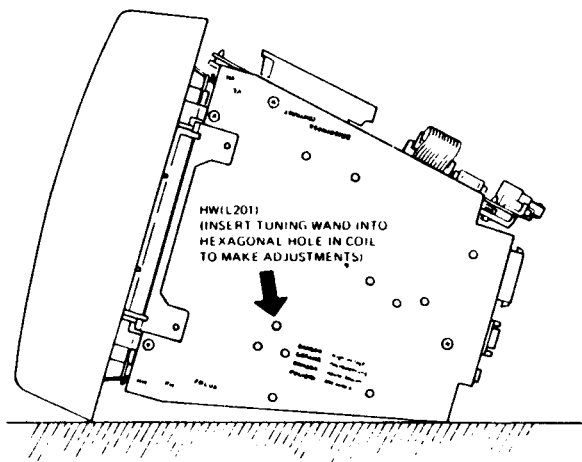

M.A. 081. 83

Figure 4-4 Horizontal Width Adjustment

4.2.5.2 Vertical Height – Check and adjust the vertical height as follows.

1. Use your flexible ruler to measure the height of one column in the alignment pattern of E's. If the column does not measure 127 mm, adjust the vertical height (VH) control (Figure 4-1).
2. Readjust the vertical linearity, if necessary (Paragraph 4.2.2.3).

5 SET-UP REFERENCE MATERIAL

Refer to the *VT220 Owner's Manual* for the set-up summaries for the VT220 video terminal.

5.1 USING SET-UP

You enter set-up by pressing the **Set-Up** key (F3) on the top row of the VT220 keyboard. You move to different fields in each set-up menu by using the arrow keys. The field you are in is highlighted in reverse video.

You use the **Enter** key to select any of the following.

- A set-up menu – Move to the field selecting the menu. Then press **Enter**, and the new menu will appear on the screen.
- An action field – Move to the desired field. Then press **Enter**, and the terminal will perform the action.
- A parameter field – These fields have more than one value. Move to the desired field. Then use **Enter** to step through the values for the field. When the desired value is displayed, move to a new field (or exit set-up) to select that value.

You exit set-up by pressing the **Set-Up** key.

5.2 SAVING OR RECALLING SET-UP VALUES

You can save values selected in set-up, or recall the last saved values, as follows.

1. Move to the **Set-Up Directory** screen.
2. Move to the **Save** or **Recall** field.
3. Press **Enter**.

Save stores the current values of most set-up features in all set-up screens. The terminal uses these values until you change them. **Recall** changes the current values to the last saved values.

A VT220 DOCUMENTATION

The following documents on the VT220 are available from Digital.

VT220 Owner's Manual EK-VT220-UG

This manual provides the user with the information needed to operate and service the VT220 terminal. The manual includes an overview of the VT220's physical and functional structure. Specific operational features such as set-up procedures, controls and indicators, communication interfaces, and test functions are also described.

Installation Guide EK-VT220-IN

This guide provides the user with the information needed to unpack, assemble, and bring the VT220 terminal to operating status.

VT220 Programmer Reference Manual EK-VT220-RM

This manual provides the programmer with the information needed to use the communication and character processing features of the VT220 video terminal.

VT220 Programmer Pocket Guide EK-VT220-HR

This guide provides the programmer with a summary of the information needed to program the VT220 video terminal.

VT220 Pocket Service Guide EK-VT220-PS

This guide provides service personnel with the information needed to test, troubleshoot, and repair the VT220 video terminal.

VT220 Technical Manual

EK-VT220-TM

This manual provides the user with a technical description to isolate and repair VT220 problems that go beyond the FRU replacement level of repair. This manual is for models A, B, and C. An addendum to the manual covers models D, E, and F. The manual includes an overview of both hardware and software components, and detailed descriptions of communication components and subsystems to the major circuit level.

VT220 Video Terminal IPB

EK-VT220-IP

This document is a detailed parts breakdown of the VT220 field replaceable units. This document does not contain part numbers for components on the printed circuit boards. However, these components are listed in the *VT220 Field Maintenance Print Set*, ordered separately.

VT220 Field Maintenance Print Set

MP-01732-01

This document provides the user with a complete set of electrical and mechanical schematic diagrams for the VT220 terminal.

VT220 Modem User Guide

EK-VT22M-UG

This guide describes how to install, operate, and test the VT22X modem.

B FRU EXPLODED VIEW DRAWING

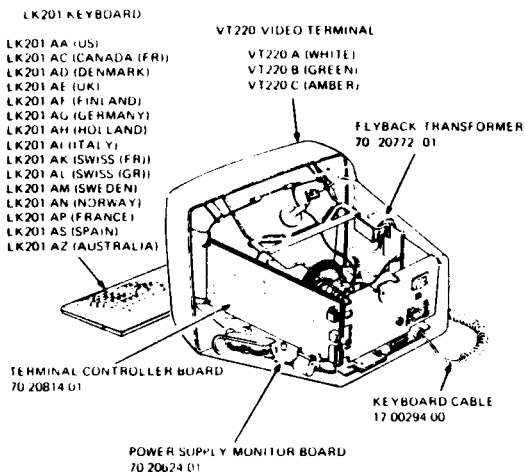

NOTE
THE MODEM OPTION (VT22X), EIA CABLE WITH SHORTING PLUG (70 21475 01), AND TELEPHONE CABLE (17 00089 01) ARE NOT SHOWN.

VT220 FRU 01
MA 047 88

Figure B-1 VT220 FRUs, Models A, B, and C (Exploded View)

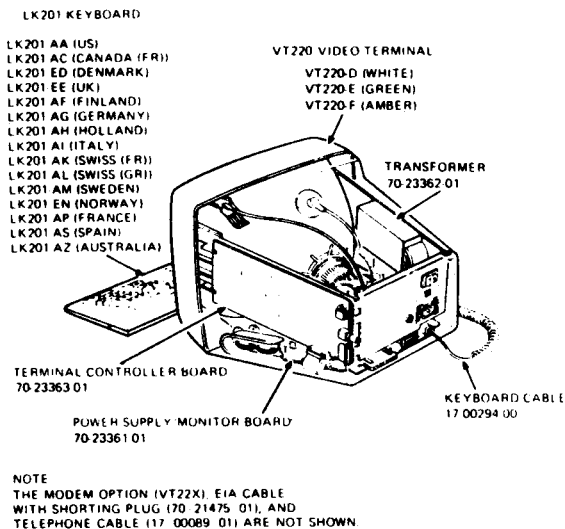

Figure B-2 VT220 FRUs, Models D, E, and F
 (Exploded View)

C CABLE INFORMATION

Figure C-1 shows the cable connections for the VT220. Table C-1 lists the interface cables, and Table C-2 lists the modem control selections.

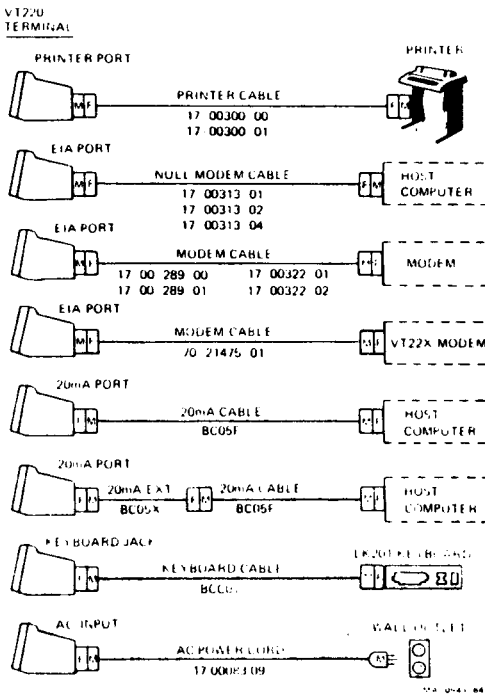

Figure C-1 Cable Summary

Table C-1 Interface Cables

Part Number	Length	Connector
Printer Cable (VT220 to printer)		
17-00300-00	3 m (10 ft)	9-pin F RS232
17-00300-01	7.6 m (25 ft)	to 25-pin F RS232
Null Modem Cable (VT220 to host)		
17-00313-01	3 m (10 ft)	25-pin F RS232
17-00313-02	7.6 m (25 ft)	to 25-pin F RS232
17-00313-04	15.2 m (50 ft)	
Modem Cable (VT220 to host)		
17-00289-00	3 m (10 ft)	25-pin F RS232
17-00289-01	7.6 m (25 ft)	to 25-pin M RS232
Modem Cable (VT220 to modem)		
17-00322-01	3 m (10 ft)	25-pin F RS232
17-00322-02	7.6 m (25 ft)	to 25-pin M RS232
Modem Cable (VT200 to VT22X modem)		
70-21475-01	-	25-pin F RS232 to 25-pin M RS232
20 mA Cable (VT220 to host)		
BC05F-15	4.5 m (15 ft)	8-pin M to 8-pin M
BC05F-50	15.2 m (50 ft)	
20 mA Extension (VT220 to 20 mA cable)		
BC05X-15	4.5 m (15 ft)	8-pin to 8-pin
BC05X-50	15.2 m (50 ft)	
Keyboard Cable (VT220 to keyboard)		
17-00294-00	1.8 m (6 ft)	Telephone jack
AC Power Cable		
17-00083-09	-	Output to ac input

Table C-2 Modem Control Selections

Selection	Description	Usual Application
EIA data leads only	Full duplex, no EIA modem control (data leads only)	Full-duplex communication with a null modem (direct) connection to the computer, or with a modem that does not use modem control signals
EIA modem control	Full duplex with EIA modem control	Full-duplex communication with a modem that uses modem control signals, or with a port on the host computer supporting modem controls

D PHYSICAL/FUNCTIONAL DIAGRAM

Figures D-1 and D-2 are physical/functional diagrams showing how VT220 components work together. Figure D-1 is for models A, B, and C. Figure D-2 is for models D, E, and F.

NOTE

All voltage readings are based on a line voltage of 115 Vac. Your readings may differ in accordance with any variations in your line voltage.

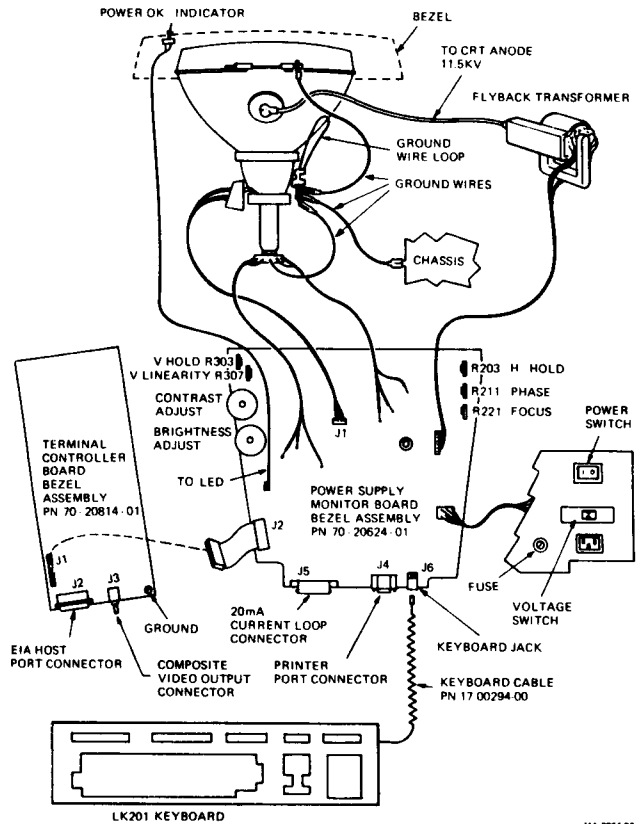

Figure D-1 Physical/Functional Diagram (Models A, B, and C)

POWER SUPPLY/MONITOR BOARD

J1 CRT Yoke Cable Connector

- Pin 1 Vertical (Yellow)
- 2 Horizontal (Red)
- 3 Horizontal (Green)
- 4 Vertical (Brown)

J2 Power Supply/Monitor Board to J1 Controller Connector

- Pin 1 Test/status
- 2 -20 mA transmit -
- 3 +20 mA transmit +
- 4 Keyboard transmit data
- 5 Printer transmit data
- 6 Printer data set ready
- 7 +5 Vdc
- 8 +5 Vdc
- 9 Ground
- 10 Ground
- 11 Video
- 12 Horizontal
- 13 Video ground
- 14 Video ground
- 15 Vertical
- 16 Ground
- 17 Ground
- 18 +5 Vdc
- 19 +5 Vdc
- 20 +12 Vdc
- 21 -12 Vdc
- 22 + Printer receive data
- 23 Keyboard receive data
- 24 20 mA receive +
- 25 20 mA receive -
- 26 Production reset

J4 Printer Port Connector

- Pin 1 Protective ground
- 2 Printer transmit data
- 3 Printer receive data
- 4 Request to send
- 5 Data terminal ready
- 6 Printer data set ready
- 7 Signal ground
- 8 Not used
- 9 Not used

J5 20 mA Current Loop Connector

- Pin 1 Not used
- 2 Transmit -
- 3 Receive -
- 4 Not used
- 5 Transmit +
- 6 Not used
- 7 Receive +
- 8 Protective ground

J6 Keyboard Connector

- Pin 1 Keyboard receive
- 2 Ground
- 3 +12 Vdc
- 4 +5 transmit

TERMINAL CONTROLLER BOARD

J2 (EIA Connector)

- Pin 1 (AA)Protective ground
- 2 (BA) Transmitted data
- 3 (BB) Received data
- 4 - Request to send
- 5 (CB) Clear to send
- 6 (CC) Data set ready
- 7 (AB) Signal ground (common ground)
- 8 (CF) Received line signal detector
- 9 - +12 Vdc
- 10 - -12 Vdc
- 11 - Not used
- 12 (CI) Speed mode indicate
- 13 - +5 Vdc
- 14 - Data/talk
- 15 - Not used
- 16 - Not used
- 17 - Not used
- 18 (LL) Local loopback test
- 19 - Not used
- 20 (CD) Data terminal ready
- 21 - Not used
- 22 - Not used
- 23 (CH) Data rate select
- 24 - Not used
- 25 (TM) Test mode indicate

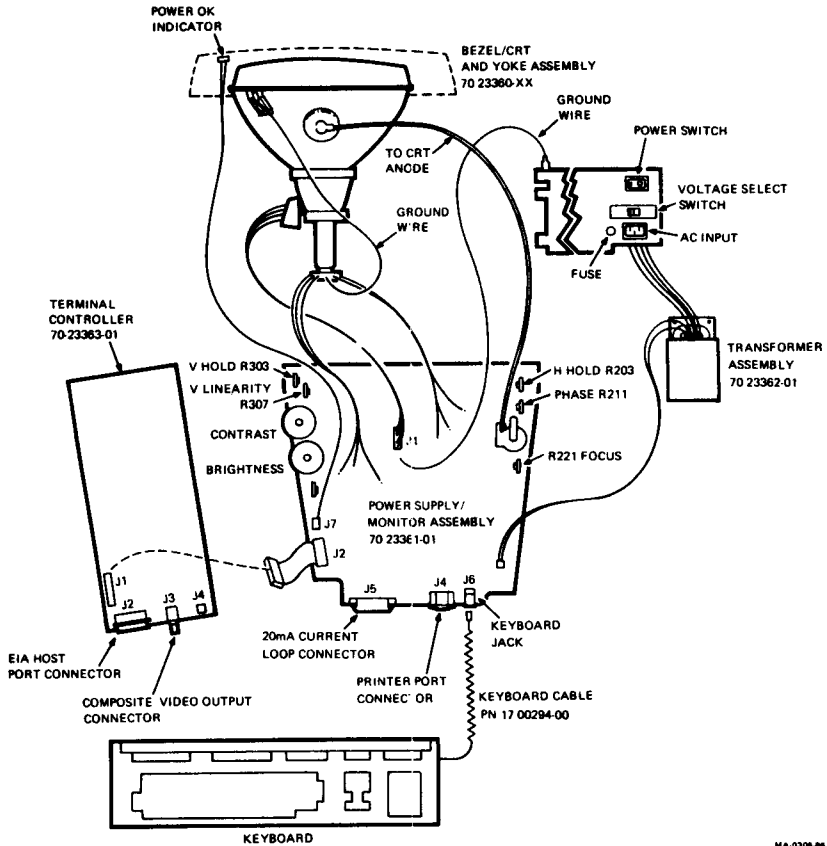

MA 0308-86

Figure D-2 Physical/Functional Diagram (Models D, E, and F)

POWER SUPPLY/MONITOR BOARD

J1 CRT Yoke Cable Connector

- Pin 1 Vertical (Yellow)
- 2 Horizontal (Red)
- 3 Horizontal (Green)
- 4 Vertical (Brown)

J2 Power Supply/Monitor Board to J1 Controller Connector

- Pin 1 Test/status
- 2 -20 mA transmit -
- 3 +20 mA transmit +
- 4 Keyboard transmit data
- 5 Printer transmit data
- 6 Printer data set ready
- 7 +5 Vdc
- 8 +5 Vdc
- 9 Ground
- 10 Ground
- 11 Video
- 12 Horizontal
- 13 Video ground
- 14 Video ground
- 15 Vertical
- 16 Ground
- 17 Ground
- 18 +5 Vdc
- 19 +5 Vdc
- 20 +12 Vdc
- 21 -12 Vdc
- 22 + Printer receive data
- 23 Keyboard receive data
- 24 20 mA receive +
- 25 20 mA receive -
- 26 Production reset

J4 Printer Port Connector

- Pin 1 Protective ground
- 2 Printer transmit data
- 3 Printer receive data
- 4 Request to send
- 5 Data terminal ready
- 6 Printer data set ready
- 7 Signal ground
- 8 Not used
- 9 Not used

J5 20 mA Current Loop Connector

- Pin 1 Not used
- 2 Transmit -
- 3 Receive -
- 4 Not used
- 5 Transmit +
- 6 Not used
- 7 Receive +
- 8 Protective ground

J6 Keyboard Connector

- Pin 1 Keyboard receive
- 2 Ground
- 3 +12 Vdc
- 4 +5 transmit

TERMINAL CONTROLLER BOARD

J2 (EIA Connector)

- Pin 1 (AA)Protective ground
- 2 (BA)Transmitted data
- 3 (BB) Received data
- 4 (CA)Request to send
- 5 (CB) Clear to send
- 6 (CC)Data set ready
- 7 (AB)Signal ground (common ground)
- 8 (CF) Received line signal detector
- 9 - +12 Vdc
- 10 - -12 Vdc
- 11 - Not used
- 12 (CI) Speed mode indicate
- 13 - +5 Vdc
- 14 - Data/talk
- 15 - Not used
- 16 - Not used
- 17 - Not used
- 18 - Not used
- 19 - Not used
- 20 (CD)Data terminal ready
- 21 - Not used
- 22 - Not used
- 23 (CH)Data rate select
- 24 - Not used
- 25 - Not used