

DEChub

Network Configuration

Part Number: EK-CONFIG-CG. A01

October 1996

This manual describes platforms and modules used to build networks.

Digital Equipment Corporation makes no representations that the use of its products in the manner described in this publication will not infringe on existing or future patent rights, nor do the descriptions contained in this publication imply the granting of licenses to make, use, or sell equipment or software in accordance with the description.

Possession, use, or copying of the software described in this publication is authorized only pursuant to a valid written license from Digital or an authorized sublicensor.

© Digital Equipment Corporation 1996. All rights reserved. Printed in U.S.A

The following are trademarks of Digital Equipment Corporation:

clearVISN, the clearVISN logo, DEC, DECagent, DECbridge, DECbrouter, DECchub, DECpacketprobe, DECreeper, DECserver, DECswitch, Digital, the Digital logo, Digital MultiStack System, enVISN, GIGAswitch, HUBwatch, MANAGEWORKS, OpenVMS, PATHWORKS, POLYCENTER, RoamAbout, RouteAbout, ThinWire, and ULTRIX.

The following are third-party trademarks:

AppleTalk is a registered trademark of Apple Computer, Inc.

Bay Networks and Wellfleet are trademarks of Bay Networks, Inc.

Cisco is a registered trademark of Cisco Systems, Inc.

DynaText is a registered trademark of Electronic Book Technologies, Inc.

IBM is a registered trademark of International Business Machines Corporation.

HP is a trademark and OpenView is a registered trademark of Hewlett-Packard Company.

Microsoft Windows, Windows NT, Windows, and Windows 95 are trademarks of Microsoft Corporation.

NetView is a registered trademark of International Business Machines Corporation.

Novell and Netware are registered trademarks and ManageWise and NMS are trademarks of Novell Inc.

UNIX is a registered trademark of X/Open Company Ltd.

VINES is a registered trademark of Banyan Systems Incorporated.

3Com is a registered trademark of 3Com Corporation.

All other trademarks and registered trademarks are the property of their respective holders.

Contents

Preface	ix
----------------------	----

1 Platforms

1.1 Platform Types	1-1
1.2 DEChub 90	1-2
1.3 DEChub 900 MultiSwitch	1-4
1.4 Digital MultiStack System	1-7
1.5 DEChub ONE	1-9
1.6 DEChub ONE-MX	1-10

2 Selecting Products

2.1 Platform Selection	2-1
2.2 Repeater Module Selection	2-2
2.3 PORTswitch Module Selection	2-6
2.4 Bridge Module Selection	2-8
2.5 Switch Module Selection	2-9
2.6 Concentrator Module Selection	2-11
2.7 Brouter Module Selection	2-12
2.8 Router Module Selection	2-14
2.9 Network Access Server Module Selection	2-15
2.10 Token Ring Module Selection	2-17

3 Network Modules

3.1 Network Module Types	3-1
3.2 Repeaters	3-2
3.3 Port Switches	3-27
3.4 Bridges	3-38
3.5 Switches	3-45
3.6 Routers	3-59

3.7	Routers	3-62
3.8	Concentrators	3-65
3.9	Network Access Servers	3-74
3.10	Management Agents	3-91
3.11	Token Ring	3-94
3.12	Probes	3-107

4 Management Methods

4.1	Introduction	4-1
4.2	In-Band Management	4-1
4.3	Out-of-Band Management	4-7

5 Management Tools

5.1	Introduction	5-1
5.2	clearVISN Applications	5-2
5.3	Router Configurator	5-4
5.4	Router Manager	5-6
5.5	MultiChassis Manager	5-8
5.6	Stack Manager	5-10
5.7	VLAN Manager	5-11
5.8	Flash Loader	5-14
5.9	Recovery Manager	5-15
5.10	RMON Manager	5-18

6 Configuration Examples

6.1	Introduction	6-1
6.2	Case 1: Managed 10BaseT Workgroup	6-2
6.3	Case 2: Small Mixed Media Ethernet Workgroup	6-4
6.4	Case 3: Multi-Ethernet Hub	6-6
6.5	Case 4: Multi-Ethernet (Building) Backbone	6-9
6.6	Case 5: Collapsed Fiber Optic (Campus) Ethernet Backbone	6-14
6.7	Case 6: Shared FDDI Backbone	6-19
6.8	Case 7: Switched FDDI Backbone	6-22
6.9	Case 8: Remote Access Using Routers and Access Servers	6-25
6.10	Case 9: Connecting Remote Sites to a Cisco Backbone	6-27

A FDDI Configuration Capabilities

A.1	Configuration Guidelines and Rules	A-2
-----	----------------------------------------------	-----

A.2	Dual Ring Configurations	A-4
A.3	Tree Configurations.	A-5
A.4	DECconcentrator 900MX	A-6
A.5	DECconcentrator 900TH.	A-7
A.6	DECconcentrator 900FH.	A-8
A.7	DECswitch 900EF.	A-9
A.8	PEswitch 900TX	A-10
A.9	FDDI in the Hub Backplane	A-11
A.10	Default Configurations	A-14
A.11	FDDI Tree Configuration Examples.	A-17
A.12	Dual Ring Configuration Examples	A-25
A.13	Fault Tolerance in Dual Rings	A-31
A.14	Fault Tolerance in Trees	A-33
A.15	Token Ordering of Trees or Dual Rings	A-35
A.16	Quick PC Trace Option for Concentrators	A-38
A.17	Summary of Important Configuration Features	A-39

B FDDI Overview

B.1	The Dual Ring.	B-1
B.2	Station Types.	B-3
B.3	Media Types and Maximum Distances.	B-5
B.4	Station Configurations.	B-6
B.5	Physical Topologies	B-8
B.6	Station States.	B-11
B.7	FDDI Connection Rules	B-12
B.8	Ring Operation	B-16

C Accessing Online Information

C.1	Network Product Business Web Site	C-1
C.2	Using Electronic Mail	C-1

Glossary

Index

Figures

1-1	DEChub 90	1-3
1-2	DEChub 900 MultiSwitch	1-5
1-3	Digital MultiStack System	1-7
1-4	DEChub ONE	1-9
1-5	DEChub ONE-MX	1-11
3-1	DECrepeater 90T+	3-4
3-2	DECrepeater 90T-16	3-6
3-3	DECrepeater 90TS	3-8
3-4	DECrepeater 900GM	3-11
3-5	DECrepeater 900TM	3-14
3-6	DECrepeater 90FA	3-17
3-7	DECrepeater 90FL	3-20
3-8	DECrepeater 90FS	3-22
3-9	DECrepeater 90C	3-25
3-10	PORTswitch 900TP	3-29
3-11	PORTswitch 900CP	3-32
3-12	PORTswitch 900FP	3-35
3-13	DECbridge 90	3-39
3-14	DECbridge 90FL	3-42
3-15	PEswitch 900TX	3-46
3-16	DECswitch 900EE	3-49
3-17	DECswitch 900EF	3-53
3-18	DECswitch 900FO	3-56
3-19	DECbrouer 90T1 and DECbrouer 90T2	3-60
3-20	DECwanrouter 90 and 90EW	3-62
3-21	DECconcentrator 900MX	3-66
3-22	DECconcentrator 900TH	3-68
3-23	DECconcentrator 900FH	3-71
3-24	DECserver 90TL	3-75
3-25	DECserver 90L+	3-79
3-26	DECserver 90M	3-82
3-27	DECserver 900TM	3-85
3-28	DECserver 900GM	3-88
3-29	DECagent 90	3-91
3-30	DECmau 900TH	3-95
3-31	DECswitch 900ET	3-98
3-32	DECrepeater 900SL	3-101
3-33	DECrepeater 900TL	3-103
3-34	DECrepeater 900FL	3-105
3-35	DECpacketprobe 90	3-107
3-36	DECpacketprobe 900RR	3-110
6-1	Managed 10BaseT Workgroup	6-3
6-2	Small Mixed Media Ethernet Workgroup	6-5
6-3	Multi-Ethernet Hub	6-7

6-4	Multi-Ethernet Hub, LAN Interconnect Window	6-8
6-5	Multi-Ethernet Backbone Network	6-11
6-6	Central Department LAN Interconnect Window	6-12
6-7	Department 4 LAN Interconnect Window	6-13
6-8	Collapsed Fiber Optic Ethernet Backbone	6-16
6-9	Central Department LAN Interconnect Window	6-17
6-10	Building 3 LAN Interconnect Window	6-18
6-11	Shared FDDI Backbone	6-20
6-12	Shared FDDI Backbone, LAN Interconnect Window	6-21
6-13	Large Network with Switched Backbone	6-23
6-14	Large Network with Switched Backbone, LAN Interconnect Window	6-24
6-15	Remote Access Using Routers and Access Servers	6-26
6-16	Connecting Remote Sites to a Cisco Backbone	6-28
A-1	Dual Ring Port Configurations	A-4
A-2	Tree Port Configurations	A-5
A-3	DECconcentrator 900MX Port Configuration Capabilities	A-6
A-4	DECconcentrator 900TH Port Configuration Capabilities	A-7
A-5	DECconcentrator 900FH Port Configuration Capabilities	A-8
A-6	DECswitch 900EF Port Configuration Capabilities	A-9
A-7	PEswitch 900TX Port Configuration Capabilities	A-10
A-8	Ring Building Blocks	A-12
A-9	Tree Building Blocks	A-13
A-10	DECconcentrator Tree Connections in Hub Backplane	A-18
A-11	Building Block Representation of Example 1	A-18
A-12	Tree Connections with Switches and Concentrators	A-19
A-13	Building Block Representation of Example 2	A-20
A-14	Tree Connections to an External FDDI Network	A-21
A-15	Building Block Representation of Example 3	A-21
A-16	External Dual Homed Connections to an FDDI Network	A-22
A-17	Building Block Representation of Example 4	A-23
A-18	Hub-Based Tree Connections to an External FDDI Network	A-24
A-19	Building Block Representation of Example 5	A-24
A-20	DECconcentrator Dual Ring Connected to an FDDI Network	A-26
A-21	Building Block Representation of Example 1	A-26
A-22	Dual Ring Connections for DECswitch 900EF	A-27
A-23	Building Block Representation of Example 2	A-28
A-24	Dual Ring Connections for PEs switch 900TX	A-29
A-25	Building Block Representation of Example 3	A-29
A-26	Self-Contained Dual Ring in the Backplane	A-30
A-27	Ring Configuration	A-32
A-28	Tree Configuration	A-34
A-29	Token Flow through Dual Ringed DEChub 900 Modules	A-36
A-30	Token Flow through Treed DEChub 900 Modules	A-37
A-31	Legal Dual Ring of Trees Topology	A-40
A-32	Illegal Dual Ring of Trees Topology	A-41
A-33	Valid FDDI Configurations for DEChub FDDI Modules	A-43

B-1	FDDI Dual Ring	B-1
B-2	FDDI Station Types	B-3
B-3	FDDI Port Types	B-6
B-4	FDDI Topologies.	B-10
B-5	Wrapped FDDI Ring.	B-11
B-6	FDDI Connection Rules	B-12
B-7	Connecting to Similar Ports	B-14

Tables

2-1	Platform Selection	2-1
2-2	DECrepeater Half-Height Modules (Twisted Pair and Coaxial)	2-2
2-3	DECrepeater Half-Height Modules (Fiber).	2-3
2-4	DECrepeater Full-Height Modules	2-5
2-5	PORTswitch Full-Height Modules	2-6
2-6	DECbridge Half-Height Modules	2-8
2-7	PEswitch/DECswitch Modules	2-9
2-8	DECconcentrator Modules	2-11
2-9	DECbrouter Modules	2-12
2-10	DECwanrouter Modules	2-14
2-11	DECserver Half-Height Modules	2-15
2-12	DECserver Full-Height Modules	2-16
2-13	Token Ring Modules.	2-17
3-1	Comparison of Supported Serial Line Standards	3-59
4-1	Modules that Provide IP Services	4-3
5-1	clearVISN Applications:	5-2
B-1	FDDI Connection Rules and Station States	B-15

Preface

About this Manual

This manual describes the products used to build and configure networks. The intent is to provide a summary of the products that are available.

Intended Audience

This manual has two major audiences:

- Pre-sales technical support—includes Digital’s technical sales force and Value Added Resellers (VARs).
- Post-sales support—includes Digital’s Multivendor Customer Service personnel and Digital’s customers.

What Is in This Manual

This manual contains the following information:

- A summary of the DEChub and Digital MultiStack System products.
- An overview of software management methods and tools.
- Some network examples showing how DEChub and Digital MultiStack System products are used to build networks.

What Is Not in This Manual

This manual does not contain detailed hardware specifications, installation information, or user instructions.

Structure of This Manual

This book is structured as follows:

- Chapter 1 presents an overview of the available platforms.
- Chapter 2 provides selection information for the products.
- Chapter 3 lists and describes network modules available for use with the platforms.
- Chapter 4 describes network management methods used.
- Chapter 5 describes the network management software tools available to manage the network.
- Chapter 6 contains example networks.
- Appendix A describes FDDI configuration rules.
- Appendix B describes FDDI basics.
- Appendix C tells you how to access MIBS, RFCs, and online release notes.

Other Books in This Series

Following is a list of associated documents:

Title	Document Number
DEChub Network Modules 900-Series Switch Reference	EK-SWTCH-HR
DEChub Network Modules 900-Series Concentrator Reference	EK-CONTR-HR
DEChub Network Modules Repeater Reference	EK-REPTR-HR
DEChub Network Products Problem Solving	EK-PRBSV-PS

Correspondence

Documentation Comments

If you have comments or suggestions about this document, send them to the Network Products Business Organization.

Attn.: Documentation Project Manager
FAX: (508) 486-6093
E-MAIL:doc_feedback@lkg.mts.dec.com

Online Services

To locate product specific information, refer to the following online services:

- BBS** To read the Bulletin Board System, set your modem to 8 bits, no parity, 1 stop bit and dial 508-486-5777 (U.S.)
- WWW** The Digital Equipment Corporation Network Products Business Home Page on the World Wide Web is located at the following addresses:

North America:	http://www.networks.digital.com
Europe:	http://www.networks.europe.digital.com
Australia:	http://www.digital.com.au/networks

How to Order Additional Documentation

To order additional documentation, use the following information:

To Order:	Contact:
By Telephone	USA (except Alaska, New Hampshire, and Hawaii): 1-800-DIGITAL (1-800-344-4825) Alaska, New Hampshire, and Hawaii: 1-603-884-6660 Canada: 1-800-267-6215
Electronically (USA. only)	Dial 1-800-DEC-DEMO (For assistance, call 1-800-DIGITAL)
By Mail (USA and Puerto Rico)	DIGITAL EQUIPMENT CORPORATION P.O. Box CS2008 Nashua, New Hampshire 03061 (Place prepaid orders from Puerto Rico with the local Digital subsidiary: 809-754-7575)
By Mail (Canada)	DIGITAL EQUIPMENT of CANADA LTD. 940 Belfast Road Ottawa, Ontario, Canada K1G 4C2 Attn.: A&SG Business Manager
Internationally	DIGITAL EQUIPMENT CORPORATION Attn.: A&SG Business Manager c/o local Digital subsidiary or approved distributor
Internally	U.S. Software Supply Business (SSB) DIGITAL EQUIPMENT CORPORATION 10 Cotton Road Nashua, New Hampshire 03063

Firmware Updates

Digital continuously improves the quality of products through periodic firmware releases. To ensure the high quality and interoperability of products, you should always use the latest available versions of firmware.

FTP Location

You can get information about the latest firmware releases from your local Digital reseller or your local Digital Sales Office. You can also get this information by reading the README file found in the

`/pub/DEC/hub900` directory at `ftp.digital.com`.

How to Register for Release Notification

Firmware updates are customer installable. To register for automatic notification of new firmware releases, return the Business Reply Card supplied with the switch product. Alternatively, you can use the Internet by sending your Name, Title, and Mailing Address to

`dechub_notice@lkg.dec.com`.

How To Load New Firmware

New firmware can be loaded using the clearVISN Flash Loader.

This chapter describes the DEChub and Digital MultiStack System hardware platforms.

1.1 Platform Types

Digital provides a variety of hardware platforms including:

- The DEChub 90
- The DEChub 900 MultiSwitch
- The Digital MultiStack System
- The DEChub ONE
- The DEChub ONE-MX.

1.2 DEChub 90

1.2 DEChub 90

The DEChub 90 chassis is designed to support the communication needs of small to mid-size work groups. Figure 1–1 displays the DEChub 90 with modules installed.

Built as an Ethernet-based backplane, the DEChub 90 chassis provides mounting, power, and backplane ThinWire Ethernet connection to accommodate up to eight half-height modules. These modules include repeaters, network access servers, bridges, and wide area routers. Network management capability is provided by the DECagent 90 and SNMP-based network management software.

Any DEChub 90 configuration that includes a DECbridge 90 or a DECrepeater 90FA network module can connect to the Ethernet backbone using the standard attachment unit interface (AUI) connector on the bridge or repeater. Two DEChub 90 chassis can be interconnected using the BNC port to create a sixteen-slot hub, which can operate and be managed as a single entity.

Features

- Supports both industry and de facto standards for seamless connection of DEChub products to non-Digital networks
- Provides plug-and-play functionality.
- Provides hot swap module replacement.
- Features a variety of modules, including repeater and bridge fiber optic support and wide area routing.
- Offers an easy migration path for scalable growth from the DEChub 90 chassis or Digital MultiStack System, to the DEChub 900 MultiSwitch enterprise hub.

1.2 DEChub 90

Figure 1-1 DEChub 90

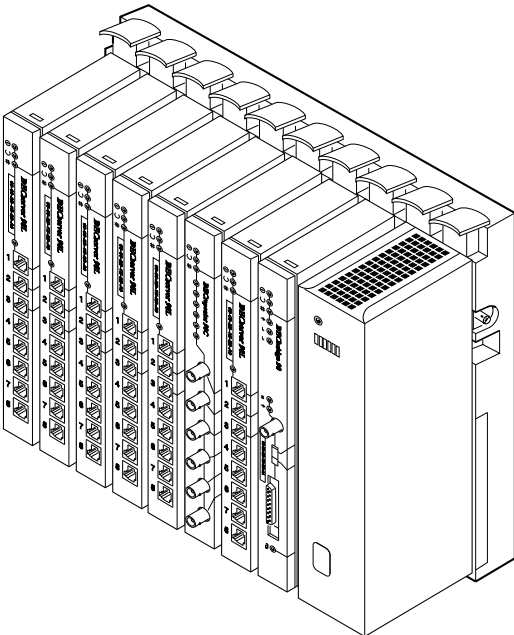

NPB-0401-96F

1.3 DEChub 900 MultiSwitch

1.3 DEChub 900 MultiSwitch

The DEChub 900 MultiSwitch chassis is a multitechnology hub that provides support ranging from simple LAN connectivity to high-speed switching. It offers high-performance network access, flexible configuration, superior network management, and security. Figure 1–2 displays the DEChub 900 with modules installed.

It is a high performance enterprise hub with a technology independent backplane. This means that Ethernet, Token Ring, FDDI, and ATM can all run on the same backplane. The hub supports large numbers of bus, ring, and cell-based connections in many combinations. Support for high throughput allows for the implementation of emerging higher bandwidth technologies such as ATM.

The DEChub 900 supports up to eight network modules, commonly referred to as full-height modules. Additionally, the hub also supports half-height modules.

The DEChub 900 integral hub management agent manages DECRepeater 90s without a DECagent 90. The DEChub 900 MultiSwitch requires an installed module to act as an IP services module. Refer to Chapter 4 for a complete listing of network modules that provide IP Services. If there are no IP services modules in a DEChub 900, it cannot be managed in-band.

You can install up to four power-supply modules in the DEChub 900. That is enough power to support most configurations with redundancy. This ensures that the hub continues to operate without interruption even if one of the power modules fails. If a power module fails, you can hot-swap the module without powering down the hub.

1.3 DEChub 900 MultiSwitch

Figure 1-2 DEChub 900 MultiSwitch

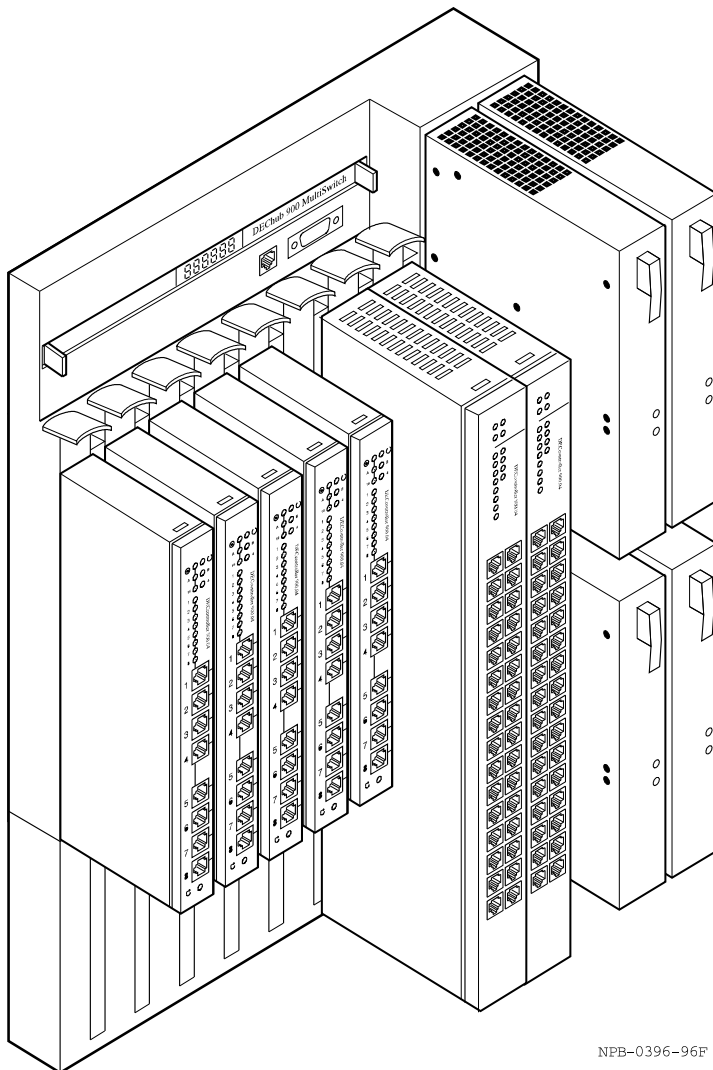

NPB-0396-96F

1.3 DEChub 900 MultiSwitch

Features

- Provides bandwidth on demand with an aggregate throughput of more than 3Gb/s.
- Supports multiple bus, ring, and cell-based connections in a several combinations (Ethernet, Token Ring, FDDI, and ATM). Including:
 - One ThinWire Ethernet, two Token Rings, and one flexible channel on the upper (48-pin) connector.
 - Fourteen flexible channels on the lower (160-pin) connector.
- Software reconfigurable backplane connections.
- Provides an open hardware architecture. No configuration restrictions or slot dependence.
- Modular power supplies (up to four supplies). Provides true hot-swap, load sharing and redundancy to prevent power-related problems, and power module failures from taking down the network.
- Integral(SNMP) hub management agent.
- Supports half-height and full-height network modules in any combination.
- Hot-swappable.

1.4 Digital MultiStack System

1.4 Digital MultiStack System

The Digital MultiStack System is a stackable hub system that allows you to use repeaters, internetworking, wireless, LAN monitoring, and management modules in stackable network configurations. The Digital MultiStack System can stack up to sixteen modules, commonly referred to as half-height modules. It can be rack mounted in a standard 19-inch rack, or distributed throughout a building. Figure 1–3 displays the Digital MultiStack System with modules installed.

Figure 1–3 Digital MultiStack System

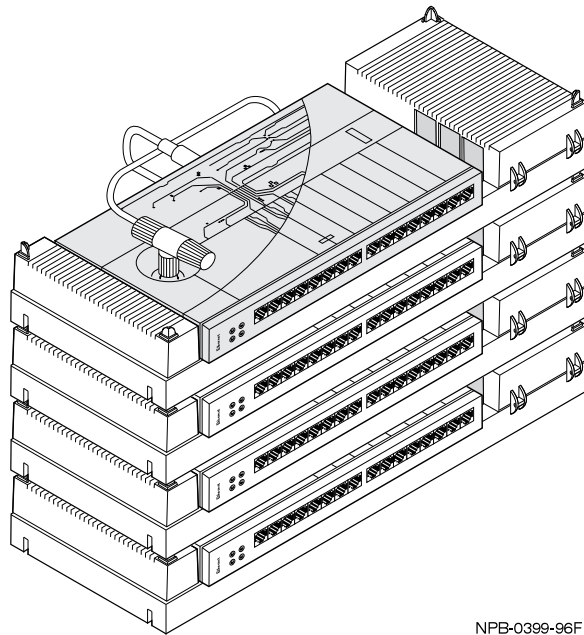

NPB-0399-96F

In the Digital MultiStack System sixteen network modules can be managed as a single SNMP management domain using network management software. In addition, the same network modules are easily removed from the Digital MultiStack System for use in a DEChub 90 or DEChub 900.

The Digital MultiStack System supports and provides hot-swap capability for any module in a stacking unit. The stacking unit comes with a stackable backplane, power supply, and ThinWire and Unshielded Twisted Pair management cables.

1.4 Digital MultiStack System

An optional attachment unit interface (AUI) connector is available for the DECrepeater 90T-16 to facilitate connections to a network backbone. Because the Digital MultiStack System integrates SNMP management via a separate management channel, it ensures management access by maintaining a continuously available management connection, even if a connection is lost to one of the stackable hubs.

Features

- Flexible, hot-swappable stackable hub system for small workgroups up to switched enterprise networks. Provides everything needed to build stackable networks quickly and cost-effectively. Allows incremental growth and increases network availability.
- Scales up to 232 managed ports in a single management domain. Lowers overall network equipment costs. Provides investment protection as network requirements grow.
- Supports SNMP management for up to sixteen stackable modules. Unique management cabling ensures continuous management uptime.
- Provides low-cost, high-speed connections to network backbones.
- Provides configuration flexibility. These hub modules work in a stack, in a rack, in a hub chassis, or as a standalone unit.

1.5 DEChub ONE

1.5 DEChub ONE

The DEChub ONE is an Ethernet-only single-slot hub that provides standalone capability for full-height network modules. The DEChub ONE provides dc power to the attached module. An attachment unit interface (AUI) on the DEChub ONE can be used to connect the attached module to a standard Ethernet backbone. An optional medium attachment unit (MAU) can be connected to the DEChub ONE AUI to connect it to a fiber-optic, ThinWire, or twisted-pair Ethernet LAN.

The DEChub ONE provides an out-of-band management (OBM) port with an associated LED for remote network management support. A setup port on the DEChub ONE enables you to configure the attached network module using a terminal device, personal computer, or terminal. Figure 1–4 displays the DEChub ONE.

Although this is an Ethernet-only hub, it can be used to supply power to FDDI and Token Ring modules.

Features

- Enables full-height network modules to operate as standalone devices.
- Suitable for desktop or rack-mounting.
- Supports Simple Network Management Protocol (SNMP) using the Serial Line Internet Protocol (SLIP).

Figure 1–4 DEChub ONE

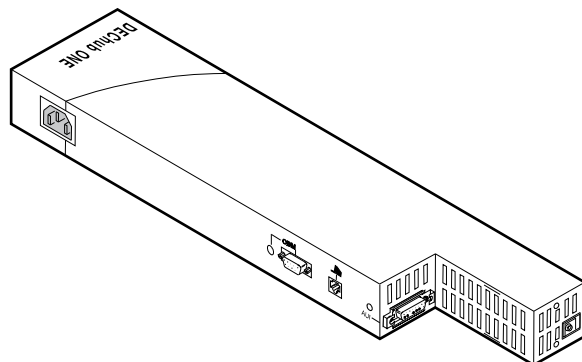

NPG-9106-95F

1.6 DEChub ONE-MX

1.6 DEChub ONE-MX

The DEChub ONE-MX is a single-slot hub that provides standalone capability for full-height network modules. An attachment unit interface (AUI) on the DEChub ONE-MX can connect an attached network module to a standard Ethernet backbone. An optional medium attachment unit (MAU) can be connected to the DEChub ONE-MX AUI to connect it to a fiber-optic, ThinWire, or twisted-pair Ethernet LAN.

Using the optional Single-Mode Fiber (SMF), Multimode Fiber (MMF), or Twisted Pair (TWP) Modular Physical Media Dependent (ModPMD) cards, the DEChub ONE-MX can connect to an FDDI network via its A and B ports. Figure 1–5 displays the DEChub ONE MX.

The DEChub ONE-MX provides an out-of-band management (OBM) port with an associated LED for remote network management support. A setup port on the DEChub ONE-MX enables you to configure the attached network module using a terminal device, personal computer, or terminal.

The DEChub ONE-MX is designed to provide power-failover capability, and can be configured into a redundant power system (optional kit required).

It includes a 6-pin MJ optical bypass relay port for connecting to an OBR device.

The DEChub ONE-MX can also be used to supply power to Token Ring modules.

Features

- Enables full-height network modules to operate as standalone devices.
- Suitable for desktop or rack-mounting.
- Can connect to an Fiber Distributed Data Interface (FDDI).
- Supports FDDI optical bypass relay (OBR) feature.
- Supports Simple Network Management Protocol (SNMP) using the Serial Line Internet Protocol (SLIP).

1.6 DEChub ONE-MX

Figure 1-5 DEChub ONE-MX

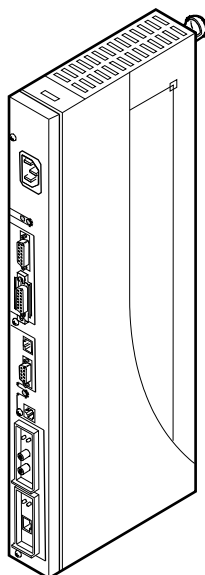

NPB-09646-96F

2

Selecting Products

This chapter contains tables that list the platform and network module characteristics.

2.1 Platform Selection

Use Table 2–1 to select the platform that meets your requirements.

Table 2–1 Platform Selection

Criteria	Digital MultiStack System	DEChub 900	DEChub 90	DEChub ONE	DEChub ONE-MX
Ethernet	Yes	Yes	Yes	Yes	Yes
FDDI	No	Yes	No	No	Yes
Token Ring	No	Yes	No	No	Yes
Backplane LANs	Cabled interconnect	Flexible channels	1	No	No
Modules Installed	16	8	8 (16)	1	1
Module size	Half height	Half and full height	Half height	Full height	Full height

2.2 Repeater Module Selection

2.2 Repeater Module Selection

Use Tables 2-2, 2-3, and 2-4 to select the repeater module that meets your requirements.

Table 2–2 DECRepeater Half-Height Modules (Twisted Pair and Coaxial)

Criteria	DECRepeater 90T16	DECRepeater 90TS	DECRepeater 90C	DECRepeater 90T+
Platform	DEChub 90, DEChub 900, standalone, or Digital MultiStack.	DEChub 90, DEChub 900, standalone, or Digital MultiStack.	DEChub 90, DEChub 900, standalone, or Digital MultiStack.	DEChub 90, DEChub 900, standalone, or Digital MultiStack.
Port Configuration	Sixteen 10BaseT, one 10Base2 when standalone or in a stack, one AUI in a stack.	Eight 10BaseT, one 10Base2 when standalone or in a stack, one AUI when standalone.	Six 10Base2, one additional 10Base2 when standalone or in a stack.	Eight 10BaseT, one 10Base2 when standalone or in a stack.
Manageability	Proxy agent in the DEChub 90 and Digital MultiStack and integral hub management agent in the DEChub 900. No standalone management.	Embedded SNMP agent. Fully manageable in any platform. Manageable via its own IP address or the integral hub manager in the DEChub 900.	Proxy agent in the DEChub 90 and Digital MultiStack and integral hub management agent in the DEChub 900. No standalone management.	Proxy agent in the DEChub 90 and Digital MultiStack and integral hub management agent in the DEChub 900. No standalone management.
IP Services	No	Yes	No	No
Traffic Counters	No	Standard repeater counters. (No internal LAN or Flex Channel counters.)	No	No
Port Switching	Module level, one internal LAN.	Module level, one internal LAN.	Module level, one internal LAN.	Module level, one internal LAN.
Intrusion Protection	No	Log error on intrusion, disable port on intrusion.	No	No

2.2 Repeater Module Selection

Criteria	DECrepeater 90T16	DECrepeater 90TS	DECrepeater 90C	DECrepeater 90T+
Eavesdrop Protection	No	Yes	No	No
Authorized Address	No	Two authorized addresses belonging to the same station per port.	No	No
Redundancy	No	No	No	No
Address Learning	Yes	Yes	Yes	Yes
Comments				No longer shipped.

Table 2–3 DECrepeater Half-Height Modules (Fiber)

Criteria	DECrepeater 90FA	DECrepeater 90FL	DECrepeater 90FS
Platform	DEChub 90, DEChub 900, standalone, or Digital MultiStack.	DEChub 90, DEChub 900, standalone, or Digital MultiStack.	DEChub 90, DEChub 900, standalone, or Digital MultiStack.
Port Configuration	One 10BaseFL/ FOIRL, one AUI, one 10Base2 when standalone or in a stack.	Four 10BaseFL/ FOIRL, one 10Base2 when standalone or in a stack.	Two 10BaseFL/ FOIRL, one AUI, one 10Base2 when standalone or in a stack.
Manageability	Proxy agent in the DEChub 90 and Digital MultiStack and integral hub management agent in the DEChub 900. No standalone management.	Proxy agent in the DEChub 90 and Digital MultiStack and integral hub management agent in the DEChub 900. No standalone management.	Embedded SNMP agent. Fully manageable in any platform. Manageable via its own IP address or the integral hub manager in the DEChub 900.
IP Services	No	No	Yes

2.2 Repeater Module Selection

Criteria	DECrepeater 90FA	DECrepeater 90FL	DECrepeater 90FS
Traffic Counters	No	No	Standard repeater counters. (No internal LAN or Flex Channel counters.)
Port Switching	Module level, one internal LAN.	Module level, one internal LAN.	Module level, one internal LAN.
Intrusion Detection	No	No	Log error on intrusion, disable port on intrusion
Eavesdrop Protection	No	No	Yes
Authorized Address	No	No	Two addresses belonging to the same station per port.
Redundancy	No	No	Yes
Address Learning	Yes	Yes	Yes
Comments	In the DEChub 90, may only be installed in slot 7 or slot 8 if the AUI is used.		In the DEChub 90, may only be installed in slot 7 or slot 8 if the AUI is used

2.2 Repeater Module Selection

Table 2–4 DECrepeater Full-Height Modules

Criteria	DECrepeater 900TM	DECrepeater 900GM
Platform	DEChub 900, DEChub ONE, or DEChub ONE-MX.	DEChub 900, DEChub ONE, or DEChub ONE-MX.
Port Configuration	Thirty two 10BaseT, one AUI in the DEChub ONE or DEChub ONE-MX.	Twenty four 10BaseT (TELCO), one AUI in the DEChub ONE or DEChub ONE-MX.
Manageability	Embedded SNMP agent. Fully manageable in any platform. Manageable via its own IP address or the integral hub manager in the DEChub 900. Use the DEChub ONE's OBM and Setup serial management ports.	Embedded SNMP agent. Fully manageable in any platform. Manageable via its own IP address or the integral hub manager in the DEChub 900. Use the DEChub ONE's OBM and Setup serial management ports.
IP Services	Yes	Yes
Traffic Counters	Standard counters (no internal LAN or Flex Channel counters).	Standard counters (no internal LAN or Flex Channel counters).
Port Switching	Module level, one internal LAN.	Module level, one internal LAN.
Intrusion Protection	Log error on intrusion, disable port on intrusion.	Log error on intrusion, disable port on intrusion.
Eavesdrop Protection	Yes	Yes
Authorized Address	Two addresses belonging to the same station, per port.	Two addresses belonging to the same station, per port.
Redundancy	No	No
Address Learning	Yes	Yes

2.3 PORTswitch Module Selection

2.3 PORTswitch Module Selection

Use Table 2–5 to select the PORTswitch module that meets your requirements.

Table 2–5 PORTswitch Full-Height Modules

Criteria	PORTswitch 900TP	PORTswitch 900CP	PORTswitch 900FP
Platform	DEChub 900, DEChub ONE, or DEChub ONE-MX.	DEChub 900, DEChub ONE, or DEChub ONE-MX.	DEChub 900, DEChub ONE, or DEChub ONE-MX.
Port Configuration	Thirty two 10BaseT, one AUI, one AUI in the DEChub ONE or DEChub ONE-MX.	Sixteen 10Base2, one AUI in the DEChub ONE or DEChub ONE-MX	Twelve 10BaseFL/FOIRL (ST-type), one AUI in the DEChub ONE or DEChub ONE-MX.
Manageability	Embedded SNMP agent. Fully manageable in any platform. Manageable via its own IP address or the integral hub manager in the DEChub 900. Use the DEChub ONE's OBM and Setup serial management ports.	Embedded SNMP agent. Fully manageable in any platform. Manageable via its own IP address or the integral hub manager in the DEChub 900. Use the DEChub ONE's OBM and Setup serial management ports.	Embedded SNMP agent. Fully manageable in any platform. Manageable via its own IP address or the integral hub manager in the DEChub 900. Use the DEChub ONE's OBM and Setup serial management ports.
IP Services	Yes	Yes	Yes
Traffic Counters	Standard counters (no internal LAN or Flex Channel counters).	Standard counters (no internal LAN or Flex Channel counters).	Standard counters (no internal LAN or Flex Channel counters).
Port Switching	Port level, six internal LANs.	Port level, six internal LANs.	Port group level, six internal LANs.
Intrusion Protection	Log error on intrusion, disable port on intrusion, pass unauthorized packet.	Log error on intrusion, disable port on intrusion, pass unauthorized packet.	Log error on intrusion, disable port on intrusion.
Eavesdrop Protection	Yes	Yes	Yes

2.3 PORTswitch Module Selection

Criteria	PORTswitch 900TP	PORTswitch 900CP	PORTswitch 900FP
Authorized Address	Sixteen addresses per 4 ports.	Sixteen addresses per 4 ports.	Two addresses belonging to the same station, per port.
Redundancy	Yes	Yes	Yes
Address Learning	Yes	Yes	Yes
Comments			Port group equals two ports.

2.4 Bridge Module Selection

2.4 Bridge Module Selection

Use Table 2–6 to select the bridge module that meets your requirements.

Table 2–6 DECbridge Half-Height Modules

Criteria	DECbridge 90	DECbridge 90FL
Platform	DEChub 90, DEChub 900, standalone, or Digital MultiStack.	DEChub 90, DEChub 900, standalone, or Digital MultiStack.
Port Configuration	One 10Base2, one AUI when standalone.	One 10BaseFL/FOIRL, one AUI when standalone.
Manageability	Fully manageable in any platform using a proxy agent.	Fully manageable in any platform using a proxy agent.
Forwarding Rate	29,694 packets per second.	29,694 packets per second.
Filtering Rate	14, 847 packets per second.	14, 847 packets per second.
Filter Type	Destination, Address, and Protocol.	Destination, Address, and Protocol.
Number of Addresses	8000 Backbone, 200 Workgroup.	8000 Backbone, 200 Workgroup.
IP Services	No	No
Address Learning	Yes	Yes

2.5 Switch Module Selection

2.5 Switch Module Selection

Use Table 2–7 to select the switch module that meets your requirements.

Table 2–7 PEs witch/DECswitch Modules

Criteria	PEswitch 900TX	DECswitch 900EE	DECswitch 900EF	DECswitch 900FO
Platform	DEChub 900, DEChub ONE, or DEChub ONE-MX.	DEChub 900, DEChub ONE, or DEChub ONE-MX.	DEChub 900, DEChub ONE, or DEChub ONE-MX.	DEChub 900, DEChub ONE, or DEChub ONE-MX.
Port Configuration	Six 10BaseT	Two AUI and four 10BaseT	Two AUI, four 10BaseT, and one DAS ANSI MIC FDDI.	Six ST-type fiber optic, and one FDDI logical rear backplane,
Manageability	Embedded SNMP agent. Fully manageable in any platform. Manageable via its own IP address or the integral hub manager in the DEChub 900.	Embedded SNMP agent. Fully manageable in any platform. Manageable via its own IP address or the integral hub manager in the DEChub 900.	Embedded SNMP agent. Fully manageable in any platform. Manageable via its own IP address or the integral hub manager in the DEChub 900.	Embedded SNMP agent. Fully manageable in any platform. Manageable via its own IP address or the integral hub manager in the DEChub 900.
Destination Address Filtering	Yes	Yes	Yes	Yes
Source Address Filtering	Yes	Yes	Yes	Yes
Protocol Address Filtering	Yes	Yes	Yes	Yes
Flash Upgradeable	Yes	Yes	Yes	Yes
User Setable Rate Limiting	Yes	Yes	Yes	Yes
Ethernet Address Table Entries	Up to 96	8,000	8,000	8,000
Secure Mode/Manual Mode	Yes	Yes	Yes	Yes

2.5 Switch Module Selection

Criteria	PEswitch 900TX	DECswitch 900EE	DECswitch 900EF	DECswitch 900FO
Supports IP Packet Fragmentation (RFC 791 and RFC 1191)	Yes	Not applicable	Yes	Yes
Supports Full Translation of Packets Between FDDI and Ethernet (IEEE802.1i)	Yes	Not applicable	Yes	Yes
Specialized Support for Nontranslating Protocols (IEEE802.1h)	Yes	Yes	Yes	Yes
IP Services	Yes	Yes	Yes	Yes

2.6 Concentrator Module Selection

2.6 Concentrator Module Selection

Use Table 2–8 to select the concentrator module that meets your requirements.

Table 2–8 DECconcentrator Modules

Criteria	DECconcentrator 900MX	DECconcentrator 900TH	DECconcentrator 900FM
Platform	DEChub 900, DEChub ONE, or DEChub ONE-MX.	DEChub 900, DEChub ONE, or DEChub ONE-MX.	DEChub 900, DEChub ONE, or DEChub ONE-MX.
Port Configuration	Six front panel ports and two backplane ports.	Fourteen front panel ports (Twelve are fixed UTP ports) and two backplane ports.	Twelve front panel ports and two backplane ports.
Manageability	Embedded SNMP agent. Fully manageable in any platform. Manageable via its own IP address or the integral hub manager in the DEChub 900.	Embedded SNMP agent. Fully manageable in any platform. Manageable via its own IP address or the integral hub manager in the DEChub 900.	Embedded SNMP agent. Fully manageable in any platform. Manageable via its own IP address or the integral hub manager in the DEChub 900.
Dual Ring Connection Supported	Yes	Yes	Yes
Tree Connection Supported	Yes	Yes	Yes
Optical Bypass Port	Yes	Yes	Yes
IP Services	Yes	Yes	Yes

2.7 Brouter Module Selection

2.7 Brouter Module Selection

Use Table 2–9 to select the brouter module that meets your requirements.

Table 2–9 DECbrouter Modules

Criteria	DECbrouter 90T1	DECbrouter 90T2	DECbrouter 90T2A
Platform	DEChub 90, DEChub 900, standalone, or Digital MultiStack.	DEChub 90, DEChub 900, standalone, or Digital MultiStack.	DEChub 90, DEChub 900, standalone, or Digital MultiStack.
Port Configuration	One 10Base2, one 10BaseT, and one 1x50 WAN port.	One 10Base2, one 10BaseT, and one 2x50 WAN ports.	One 10Base2, one 10BaseT, and one 2x50 WAN ports.
Manageability	Embedded SNMP agent. Fully manageable in any platform. Manageable via its own IP address.	Embedded SNMP agent. Fully manageable in any platform. Manageable via its own IP address.	Embedded SNMP agent. Fully manageable in any platform. Manageable via its own IP address.
Serial Line Standards	EIA-530A, RS-232/V28, RS449/RS-422/V.11, RS-449/RS422/V.10, V.35, V.36, X.21 Leased Lines.	RS-232/V28, V.35, X.21 Leased Lines.	EIA-530A, RS-232/V28, RS449/RS-422/V.11, RS-449/RS422/V.10, V.36, X.21 Leased Lines.
Protocols Routed	TCP/IP, DECnet, OSI CLMP, Novell IPX, AppleTalk, Xerox XNS, Banyan VINES.	TCP/IP, DECnet, OSI CLMP, Novell IPX, AppleTalk, Xerox XNS, Banyan VINES.	TCP/IP, DECnet, OSI CLMP, Novell IPX, AppleTalk, Xerox XNS, Banyan VINES.
Routing Protocols Supported	Integrated IS-IS, OSFP, RIP, EGO, IPX RIP, ISO IS-IS, DECnet, AppleTalk RTMP.	Integrated IS-IS, OSFP, RIP, EGO, IPX RIP, ISO IS-IS, DECnet, AppleTalk RTMP.	Integrated IS-IS, OSFP, RIP, EGO, IPX RIP, ISO IS-IS, DECnet, AppleTalk RTMP.
Data Links Supported	HDLC, X.25, Frame Relay, PPP, SDLC, SMDS.	HDLC, X.25, Frame Relay, PPP, SDLC, SMDS.	HDLC, X.25, Frame Relay, PPP, SDLC, SMDS.

2.7 Brouter Module Selection

Criteria	DECbrouter 90T1	DECbrouter 90T2	DECbrouter 90T2A
Bridging	802.1d, Filtering, LAT Compression.	802.1d, Filtering, LAT Compression.	802.1d, Filtering, LAT Compression.
IP Services	No	No	No
Comments	Best used for connecting to remote Cisco routers.	Best used for connecting to remote Cisco routers.	Best used for connecting to remote Cisco routers.

2.8 Router Module Selection

2.8 Router Module Selection

Use Table 2–10 to select the router module that meets your requirements.

Table 2–10 DECwanrouter Modules

Criteria	DECwanrouter 90	DECwanrouter 90-EW
Platform	DEChub 90, DEChub 900, standalone, or Digital Multi-Stack.	DEChub 90, DEChub 900, standalone, or Digital Multi-Stack.
Port Configuration	One 10Base2, one 10BaseT, and one 1x50 Multistandard WAN port (2x64 Kb/s).	One 10Base2, one 10BaseT, and two 1 x50 Multistandard WAN ports (2x64 Kb/s).
Manageability	Embedded SNMP agent. Manageable in any platform. Manageable via its own IP address.	Embedded SNMP agent. Manageable in any platform. Manageable via its own IP address.
Protocols Routed	TCP/IP, DECnet, OSI CLMP, Novell IPX.	TCP/IP, DECnet, OSI CLMP, Novell IPX.
Routing Protocols Supported	Integrated IS-IS, RIP, EGP, IPX RIP, ISO IS-IS, DECnet.	Integrated IS-IS, RIP, EGP, IPX RIP, ISO IS-IS, DECnet.
Data Links Supported	HDLC, X.25, DCMP (synchronous and asynchronous)	HDLC, X.25, DCMP (synchronous and asynchronous)
IP Services	No	No
Comments	Best used for connecting to DECNIS over X.25 or Frame Relay.	Best used for connecting to DECNIS over X.25 or Frame Relay.

2.9 Network Access Server Module Selection

2.9 Network Access Server Module Selection

Use Table 2–11 or Table 2–12 to select the network access server module that meets your requirements.

Table 2–11 DECserver Half-Height Modules

Criteria	DECserver 90L+	DECserver 90TL	DECserver 90M
Platform	DEChub 90, DEChub 900, standalone, or Digital MultiStack.	DEChub 90, DEChub 900, standalone, or Digital MultiStack.	DEChub 90, DEChub 900, standalone, or Digital MultiStack.
Port Configuration	Eight 6-pin MMJ.	Eight 8-pin MJ.	Eight 8-pin MJ.
Manageability	Fully manageable in any platform using a proxy agent.	Embedded SNMP agent. Fully manageable in any platform. Manageable via its own IP address.	Embedded SNMP agent. Fully manageable in any platform. Manageable via its own IP address.
Modem Control	Not applicable.	Partial two-wire.	Partial two-wire.
Software in Flash	Yes	No	Yes
Line Speed	38.4 Kb/s	57.6 Kb/s	57.6 Kb/s
Port Speed	User selectable from 1.2 Kb/s.	Autobaud or user selectable from 75 b/s up to 57.6 Kb/s.	Autobaud or user selectable from 75 b/s up to 57.6 Kb/s.
Load Balancing per Server	Yes	Not applicable	Not applicable
Load Balancing per Port	No	Yes	Yes
Protocols	LAT	LAT, TELNET, TCP/IP, UDP, ARP, SLIP, CSLIP, BOOTP/TFTP, SNMP, TD/SMP.	LAT, TELNET, TCP/IP, UDP, ARP, SLIP, CSLIP, PPP, BOOTP/TFTP, SNMP, TD/SMP, TN3270, AppleTalk, and IPX, Kerberos V4, RADIUS, SECURID.
IP Services	No	No	No

2.9 Network Access Server Module Selection

Table 2–12 DECserver Full-Height Modules

Criteria	DECserver 900TM	DECserver 900GM
Platform	DEChub 900, DEChub ONE, or DEChub ONE-MX.	DEChub 900, DEChub ONE, or DEChub ONE-MX.
Port Configuration	Thirty two 8-pin MJ.	Four 68-pin “bulk” connectors.
Manageability	Embedded SNMP agent. Fully manageable in any platform. Manageable via its own IP address.	Embedded SNMP agent. Fully manageable in any platform. Manageable via its own IP address.
Modem Control	Partial four-wire.	Selectable two or four-wire.
Software in Flash	Optional	Optional
Line Speed	115.2 Kb/s	115.2 Kb/s
Port Speed	Autobaud or user selectable from 75 b/s up to 115.2 Kb/s.	Autobaud or user selectable from 75 b/s up to 115.2 Kb/s.
Load Balancing per Server	Not applicable	Not applicable
Load Balancing per Port	Yes	Yes
Protocols	LAT, TELNET, TCP/IP, UDP, ARP, SLIP, CSLIP, BOOTP/TFTP, SNMP, TD/SMP, TN3270, PPP, Apple-Talk, and IPX, Kerberos V4, RADIUS, SECURID.	LAT, TELNET, TCP/IP, UDP, ARP, SLIP, CSLIP, BOOTP/TFTP, SNMP, TD/SMP, TN3270, PPP, Apple-Talk, and IPXKerberos V4, RADIUS, SECURID.
IP Services	Yes	Yes
Connectivity	One of six Flex Channels, or to the backplane ThinWire.	One of six Flex Channels, or to the backplane ThinWire.

2.10 Token Ring Module Selection

2.10 Token Ring Module Selection

Use Table 2–13 to select the token ring module that meets your requirements.

Table 2–13 Token Ring Modules

Criteria	DECmau 900TH	DECrepeater 900SL	DECrepeater 900TL	DECrepeater 900FL
Platform	DEChub 900	DEChub 900	DEChub 900	DEChub 900
Port Configuration	Twenty four 8-pin MJ.	Two 8-pin MJ and one 10BaseT.	Two DB9 and one 10BaseT.	Two ST-type fiber optic, and two 8-pin MJ on the rear cover.
Manageability	Embedded SNMP agent. Fully manageable in any platform. Manageable via its own IP address or the DEChub 900 integral hub management agent address.	Fully manageable in any platform. Manageable via the DEChub 900 integrate hub management agent address.	Fully manageable in any platform. Manageable via the DEChub 900 integrate hub management agent address.	Fully manageable in any platform. Manageable via the DEChub 900 integrate hub management agent address.
IP Services	No	No	No	No

Network Modules

This chapter contains detailed information about the network modules.

3.1 Network Module Types

Network modules are classified according to application, network type, and size. Applications are determined by module function. Network types are existing standards. Size indicates the module's size (full-height or half-height) and use in the platforms.

Application indicates the module functionality and includes:

- Repeaters
- PORTswitches
- Bridges
- Switches
- Concentrators
- Network Access Servers
- Routers
- Brouters
- Management agents
- Token ring Multistation Access Units (MAUs) and repeaters
- Probes

Network types include:

- Ethernet
- FDDI
- Token Ring

3.2 Repeaters

Modules are provided in two sizes:

- Half-height modules are designed for use in either the DEChub 90, the DEChub 900 MultiSwitch or the Digital MultiStack System.
- Full-height modules are designed for use in the DEChub 900 MultiSwitch.

Not all module sizes are provided for all applications and network types.

NOTE

Most half-height modules are packaged with a back cover and power supply for standalone use.

Full-height modules require the DEChub ONE or DEChub ONE-MX for standalone operation. This provides the power necessary for a standalone configuration. It must be ordered in addition to the module.

3.2 Repeaters

The DECrepeaters provide network connectivity to a variety of Ethernet devices ranging from personal computers to mainframe systems. Repeater characteristics are listed below. Not all functions are supported on all network modules.

- Support for several cable types including twisted-pair (both unshielded and shielded), ThinWire coaxial cable, thick wire (attachment unit interface, AUI) and fiber optic cable. This provides connection to devices that support IEEE 802.3 (i.e., 10Base2, 10BaseT, 10BaseFL/FOIRL).
- Modules can be used standalone, stacked, and chassis-based for easy network design and configuration.
- Full repeater functionality at the port level. Unlike products that perform retiming/repeating remotely on a separate retiming module, they handle all repeating functions on a per port basis.
- Identification of malfunctioning ports and automatically segments or restores them to avoid network disruption.
- Provision of per-port statistics, such as total collision per module or number of readable frames per port.
- Secure Ethernet capability that prevents data packets generated by unknown or unauthorized end stations from accessing the network. Authorized station addresses can be set under SNMP management control.

3.2 Repeaters

- Eavesdrop protection is provided by sending data packets to the port of the destination address only. All other ports receive scrambled data.
- Intrusion protection, logs violations or disables the port.
- Dual port redundancy.
- Integral SNMP agent.
- Hot swap capability.
- Front panel LEDs for power, network activity, and port status.
- In-band and out-of-band management capabilities.
- Automatic module self-test at power up.
- One hop when the repeater is connected to a DEChub 900 MultiSwitch flex channel. Two hops when connected to the backplane ThinWire.

DECrepeater Twisted-pair Repeaters

- DECrepeater 90T-16
- DECrepeater 90T+
- DECrepeater 90TS
- DECrepeater 900GM
- DECrepeater 900TM

DECrepeater Fiber Repeaters

- DECrepeater 90FA
- DECrepeater 90FL
- DECrepeater 90FS

DECrepeater ThinWire Coaxial Repeaters

- DECrepeater 90C

3.2 Repeaters

3.2.1 DECrepeater 90T+

The DECrepeater 90T+ is an eight port IEEE 802.3 10BaseT-compliant repeater that is used for connecting personal computers, workstations, or any twisted-pair device to an Ethernet LAN. It provides one backplane ThinWire port. It also includes a ThinWire 10Base2 port connector (ThinWire BNC) on the side panel (available when installed in the stacking unit or standalone). Figure 3–1 shows the DECrepeater 90T+ network module.

Figure 3–1 DECrepeater 90T+

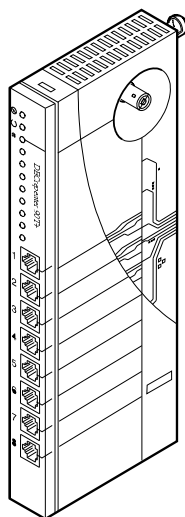

NPB-5237-96F

Platform

This half-height module is used in the:

- Digital MultiStack System
- DEChub 900 MultiSwitch
- DEChub 90
- When used standalone it requires a separate power unit.

Protocol

Ethernet 802.3

3.2 Repeaters

Media

Eight-pin MJ unshielded twisted-pair (UTP) station connectors.

LAN Connectivity

- One ThinWire BNC when in the Digital MultiStack System.
- One backplane ThinWire when installed in a DEChub 900 MultiSwitch.
- One backplane ThinWire when installed in a DEChub 90.
- One ThinWire BNC when standalone.

Upgrade Method

Not field upgradeable.

Manageability

- Digital MultiStack System—Requires the DECagent 90, the DECRepeater 90TS, or DECRepeater 90FS as the stack manager for local and remote management.
- DEChub 900 MultiSwitch—Managed through the integral hub management agent.
- DEChub 90—Requires the DECagent 90 for local or remote management.
- DEChub ONE—Not installable.
- DEChub ONE—MX—Not installable.
- Standalone—Not manageable.

Supported MIBs

- Ethernet MIB (RFC 1398)
- Repeater MIB (RFC 1516)
- Digital Extended Repeater MIB
- MIB II (RFC 1213)

IP Service

Not an IP Services provider.

3.2 Repeaters

3.2.2 DECreepeater 90T-16

The DECreepeater 90T-16 is a 16-port IEEE 802.3 10BaseT-compliant repeater that is used for connecting personal computers, workstations, or any twisted-pair device to an Ethernet LAN. It provides one backplane ThinWire port. It also includes a ThinWire 10Base2 port connector (ThinWire BNC) on the side panel (available when installed in a stacking unit or standalone). Figure 3–2 shows the DECreepeater 90T-16 network module.

Figure 3–2 DECreepeater 90T-16

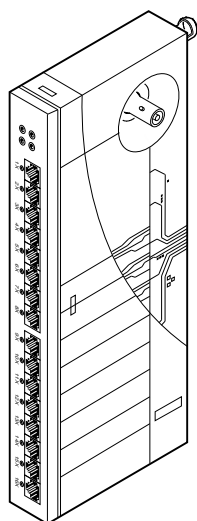

NPB-0406-96F

Platform

This half-height module is used in the:

- Digital MultiStack System
- DEChub 900 MultiSwitch
- DEChub 90
- When used standalone it requires a separate power unit.

Protocol

Ethernet 802.3

3.2 Repeaters

Media

Sixteen 8-pin MJ unshielded twisted-pair (UTP) connectors.

LAN Connectivity

- Both a ThinWire BNC and an attachment unit interface (AUI) available when installed in the Digital MultiStack System.
- One backplane ThinWire when installed in a DEChub 900 MultiSwitch.
- One backplane ThinWire when installed in a DEChub 90.
- One ThinWire BNC when standalone.

Upgrade Method

Not field upgradable.

Manageability

- Digital MultiStack System—Requires the DECagent 90, the DECrepeater 90TS, or DECrepeater 90FS as the stack manager for local and remote management.
- DEChub 900 MultiSwitch—Managed through the integral hub management agent.
- DEChub 90—Requires the DECagent 90, the DECrepeater 90TS, or DECrep-eater 90FS for local and remote management
- DEChub ONE—Not installable.
- DEChub ONE-MX—Not installable.
- Standalone—Not manageable.

Supported MIBs

- Ethernet MIB (RFC 1398)
- Repeater MIB (RFC 1516)
- Digital Extended Repeater MIB
- MIB II (RFC 1213)

IP Service

Not an IP Services provider.

3.2 Repeaters

3.2.3 DECrepeater 90TS

The DECrepeater 90TS is an eight-port 802.3 10BaseT repeater with built-in SNMP management and Ethernet port security that is used for connecting personal computers, workstations, or any twisted-pair device to an Ethernet LAN.

The unit has a ThinWire 10Base2 port connector (ThinWire BNC) on the side panel. An optional attachment unit interface (AUI) connector on the back cover provides an external network connection when used as a standalone unit or in the Digital MultiStack System. Figure 3–3 shows the DECrepeater 90TS network module.

Figure 3–3 DECrepeater 90TS

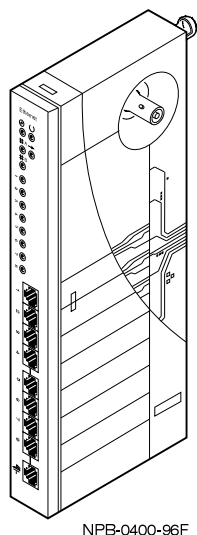

Platform

This half-height module is used in the:

- Digital MultiStack System
- DEChub 900 MultiSwitch
- DEChub 90
- When used standalone it requires a separate power unit.

Protocol

Ethernet 802.3

3.2 Repeaters

Media

Eight 8-pin MJ unshielded twisted-pair (UTP) connectors.

LAN Connectivity

- One ThinWire BNC when installed in Digital MultiStack System
- Backplane access to a ThinWire segment and/or the flex channel when installed in a DEChub 900 MultiSwitch.
- One backplane ThinWire when installed in a DEChub 90.
- One ThinWire BNC or one AUI (requires the back cover) when standalone.

Upgrade Method

- Flash Loader.
- TFTP via the setup port.

Manageability

- Digital MultiStack System—Managed through the module's built in SNMP agent or through the stack manager.
- DEChub 900 MultiSwitch—Managed through the module's built in SNMP agent or through the integral hub management agent.
- DEChub 90—Managed through the module's built in SNMP agent.
- DEChub ONE—Not installable.
- DEChub ONE-MX—Not installable.
- Standalone—Managed through the module's built in SNMP agent

Supported MIBs

- Ethernet MIB (RFC 1398)
- Repeater MIB (RFC 1516)
- Digital Extended Repeater MIB
- DEChub 900 Public Common MIB
- MIB II (RFC 1213)

IP Service

Provides IP Services.

3.2 Repeaters

Features

- Has per port security for eavesdropping and intrusion protection.
- Can serve as the stack manager and SNMP proxy agent for other repeaters.
- Supports two addresses per port, allowing for both a physical and DECnet address to be seen and recorded.
- Supports Out-of-Band Management, which provides an SNMP path in addition to normal in-band management by using the Serial Line Internet Protocol (SLIP) through the front-panel serial port on the module, when the module is installed in the Digital MultiStack System, DEChub 90, or as a standalone unit.
- Provides security and statistics capability.

3.2 Repeaters

3.2.4 DECrepeater 900GM

The DECrepeater 900GM module is an 802.3 10BaseT (two 50-pin twisted-pair Telco connectors), 24-port repeater designed for use with either 100 ohm shielded (STP) or unshielded (UTP) twisted-pair wire. In addition, an AUI connector provided on the front bezel supports connection to 10Base5 (thick wire) backbones.

When coupled with the DEChub ONE single-slot chassis and appropriate adapter, the DECrepeater 900GM supports AUI, ThinWire, twisted-pair, or 10BaseFL/FOIRL (fiber) for connection to backbone networks.

Figure 3–4 shows the DECrepeater 900GM network module.

Figure 3–4 DECrepeater 900GM

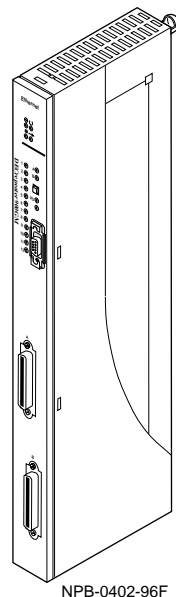

Platform

This full-height module is used in the:

- DEChub 900 MultiSwitch
- DEChub ONE
- DEChub ONE-MX.

3.2 Repeaters

Protocol

Ethernet 802.3

Media

Two 50-pin twisted pair Telco connectors supporting 24 total (2x12) STP/UTP ports, and one AUI 10Base5 port.

LAN Connectivity

- When installed in the DEChub 900 MultiSwitch, the module can be connected to the ThinWire Ethernet LAN and/or any one of the six flex channels. Also one AUI on the front panel.
- Two AUIs when installed in the DEChub ONE or DEChub ONE-MX.

Upgrade Method

- Flash Loader.
- TFTP via the Setup port.

Manageability

- Digital MultiStack System—Not installable.
- DEChub 900 MultiSwitch—Managed through the module's built in SNMP agent or through the integral hub management agent.
- DEChub 90—Not installable.
- DEChub ONE—Managed through the module's built in SNMP agent.
- DEChub ONE-MX—Managed through the module's built in SNMP agent.
- Standalone—Not installable.

Supported MIBs

- Ethernet MIB (RFC 1398)
- Repeater MIB (RFC 1516)
- Digital Extended Repeater MIB
- DEChub 900 Public Common MIB
- MIB II (RFC 1213)
- RMON

3.2 Repeaters

- Alarms
- Events

IP Service

Provides IP Services.

Features

- Has per port security for eavesdropping and intrusion protection.
- Supports two addresses per port, allowing for both a physical and DECnet address to be seen and recorded.
- Offers per port statistics for monitoring repeater traffic.
- Supports Out-of-Band Management, which provides an SNMP path in addition to normal in-band management by using the Serial Line Internet Protocol (SLIP) through the OBM port on the DEChub ONE or DEChub ONE-MX.
- Supports RMON.

3.2 Repeaters

3.2.5 DECrepeater 900TM

The DECrepeater 900TM module is an 802.3 10BaseT (twisted-pair) 32-port repeater designed for use with either 100 ohm shielded (STP) or unshielded twisted-pair (UTP) wire.

Figure 3–5 shows the DECrepeater 900TM network module.

Figure 3–5 DECrepeater 900TM

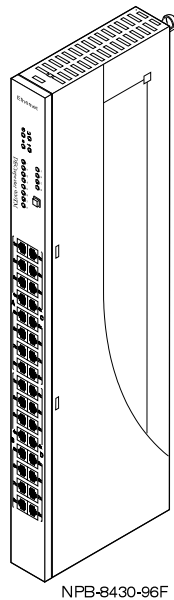

Platform

This full-height module is used in the:

- DEChub 900 MultiSwitch
- DEChub ONE
- DEChub ONE-MX.

Protocol

Ethernet 802.3

3.2 Repeaters

Media

Thirty two 8-pin MJ ports using either 100 ohm shielded or unshielded twisted-pair.

LAN Connectivity

- When installed in the DEChub 900 MultiSwitch, the module can be connected to the ThinWire Ethernet LAN and/or any one of the six flex channels.
- One AUI when installed in the DEChub ONE or DEChub ONE-MX.

Upgrade Method

- Flash Loader
- TFTP via the Setup port

Manageability

- Digital MultiStack System—Not installable.
- DEChub 900 MultiSwitch—Managed through the module's built in SNMP agent or through the integral hub management agent.
- DEChub 90—Not installable.
- DEChub ONE—Managed through the module's built in SNMP agent.
- DEChub ONE-MX—Managed through the module's built in SNMP agent.
- Standalone—Not installable.

Supported MIBs

- Ethernet MIB (RFC 1398)
- Repeater MIB (RFC 1516)
- Digital Extended Repeater MIB
- DEChub 900 Public Common MIB
- MIB II (RFC 1213)
- RMON
 - Alarms
 - Events

3.2 Repeaters

IP Service

Provides IP Services.

Features

- Has per port security for intrusion/eavesdropping protection.
- Supports two addresses per port, allowing for both a physical and DECnet address to be seen and recorded.
- Provides high port density 32 10BaseT ports (8-pin MJ)
- Offers per port statistics for monitoring repeater traffic
- Supports Out-of-Band Management, which provides an SNMP path in addition to normal in-band management by using the Serial Line Internet Protocol (SLIP) through the OBM port on the DEChub ONE or DEChub ONE-MX.
- Supports RMON.

3.2 Repeaters

3.2.6 DECrepeater 90FA

The DECrepeater 90FA module is a three-port repeater that provides low-cost connections to 10BaseFL /FOIRL fiber using ST-type fiber optic connectors, ThinWire, and an AUI connector.

Used as a standalone unit, it provides a fiber optic link between two Ethernet LANs. It can also connect a standard Ethernet backbone and ThinWire segment. In a stack or the DEChub 90 or DEChub 900 MultiSwitch backplanes, the DECrepeater 90FA module supports point-to-point connection through fiber optic cable. The AUI port provides a low-cost thick wire backbone for hub-based applications.

It also includes a ThinWire 10Base2 port connector (ThinWire BNC) on the side panel (available when installed in the stacking unit or standalone). Figure 3–6 shows the DECrepeater 90FA network module.

Figure 3–6 DECrepeater 90FA

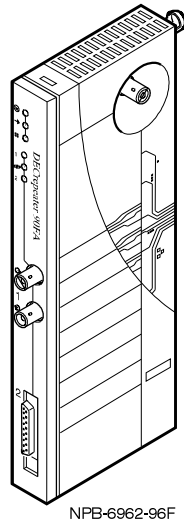

3.2 Repeaters

Platform

This half-height module is used in the:

- Digital MultiStack System
- DEChub 900 MultiSwitch
- DEChub 90
- When used standalone it requires a separate power unit.

Protocol

Ethernet 802.3

Media

One fiber optic port, one AUI connector.

LAN Connectivity

- One ThinWire BNC and either one AUI or one fiber optic (ST-type) when installed in Digital MultiStack System
- One backplane ThinWire and either one AUI or one fiber optic (ST-type) in a DEChub 900 MultiSwitch.
- One backplane ThinWire and either one AUI or one fiber optic (ST-type) when installed in a DEChub 90.
- One ThinWire BNC and either one AUI or one fiber optic (ST-type) when installed standalone.

Upgrade Method

Not field upgradeable.

Manageability

- Digital MultiStack System—Requires the DECagent 90, the DECRepeater 90TS, or DECRepeater 90FS as the stack manager for local and remote management.
- DEChub 900 MultiSwitch—Managed through the integral hub management agent.
- DEChub 90—Requires the DECagent 90, the DECRepeater 90TS, or DECRepeater 90FS for local and remote management
- DEChub ONE—Not installable.

3.2 Repeaters

- DEChub ONE-MX—Not installable.
- Standalone—Not manageable.

Supported MIBs

- Ethernet MIB (RFC 1398)
- Repeater MIB (RFC 1516)
- Digital Extended Repeater MIB
- MIB II (RFC 1213)

IP Service

Not an IP Services provider.

3.2 Repeaters

3.2.7 DECrepeater 90FL

The DECrepeater 90FL module is an 802.3 10BaseFL/FOIRL multiport fiber optic repeater with four ST-type fiber ports. It also includes a ThinWire 10Base2 port connector on the side panel (available when installed in the stacking unit or standalone). Figure 3–7 shows the DECrepeater 90FL network module

Figure 3–7 DECrepeater 90FL

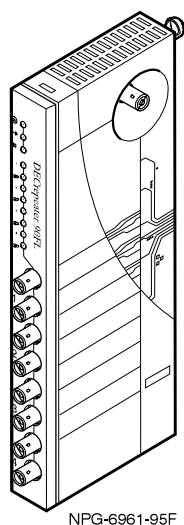

Platform

This half-height module is used in the:

- Digital MultiStack System.
- DEChub 900 MultiSwitch.
- DEChub 90.
- When used standalone it requires a separate power unit.

Protocol

Ethernet 802.3

Media

Four 10BaseFL/FOIRL-compliant ports using ST-type fiber optic connectors.

3.2 Repeaters

LAN Connectivity

- One ThinWire BNC when installed in the Digital MultiStack System
- One backplane ThinWire in a DEChub 900 MultiSwitch.
- One backplane ThinWire when installed in a DEChub 90.
- One ThinWire BNC when installed standalone.

Upgrade Method

Not field upgradeable.

Manageability

- Digital MultiStack System—Requires the DECagent 90, the DECRepeater 90TS, or DECRepeater 90FS as the stack manager for local and remote management.
- DEChub 900 MultiSwitch—Managed through the integral hub management agent.
- DEChub 90—Requires the DECagent 90, the DECRepeater 90TS, or DECRepeater 90FS for local and remote management
- DEChub ONE—Not installable.
- DEChub ONE-MX—Not installable.
- Standalone—Not manageable.

Supported MIBs

- Ethernet MIB (RFC 1398)
- Repeater MIB (RFC 1516)
- Digital Extended Repeater MIB
- MIB II (RFC 1213)

IP Service

Not an IP Services provider.

3.2 Repeaters

3.2.8 DECrepeater 90FS

The DECrepeater 90FS module is an 802.3 10BaseFL/FOIRL repeater with two fiber ports, one AUI connector, and one 10Base2 port (available when installed in the stacking unit or standalone). Figure 3–8 shows the DECrepeater 90FS network module.

The module allows you to connect three different media types. Its two 10BaseFL/FOIRL fiber ports can be configured either as a redundant port or as two separate fiber ports. Its AUI connection allows you to link the hub to thick wire.

NOTE

When installed in the DEChub 90, the DECrepeater 90FS, must be located in slot 7 or slot 8.

Figure 3–8 DECrepeater 90FS

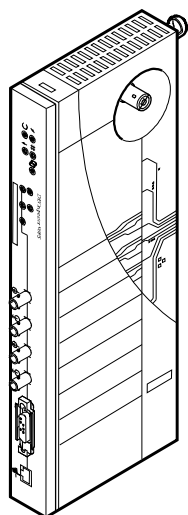

NPG-09637-95F

Platform

This half-height module is used in the:

- Digital MultiStack System
- DEChub 900 MultiSwitch

3.2 Repeaters

- DEChub 90
- When used standalone it requires a separate power unit.

Protocol

Ethernet 802.3

Media

Two 10BaseFL/FOIRL-compliant using ST-type fiber optic connectors, and one AUI.

LAN Connectivity

- One ThinWire BNC or one AUI when installed in the Digital MultiStack System
- Provides backplane access to a ThinWire segment and/or the flex channel in the DEChub 900 MultiSwitch.
- One backplane ThinWire when installed in a DEChub 90.
- One ThinWire BNC or one AUI when installed standalone.

Upgrade Method

- Flash Loader
- TFTP via the Setup port.

Manageability

- Digital MultiStack System—Managed through the module's built in SNMP agent or the stack manager.
- DEChub 900 MultiSwitch—Managed through the module's built in SNMP agent or through the integral hub management agent.
- DEChub 90—Managed through the module's built in SNMP.
- DEChub ONE—Not installable.
- DEChub ONE-MX—Not installable.
- Standalone—Managed through the module's built in SNMP agent.

Supported MIBs

- Ethernet MIB (RFC 1398)
- Repeater MIB (RFC 1516)

3.2 Repeaters

- Digital Extended Repeater MIB
- DEChub 900 Public Common MIB

IP Service

Provides IP Services.

Features

- Offers two fiber ports which may be configured as one redundant port
- Has per port security for eavesdropping and intrusion protection.
- Can serve as the stack manager and SNMP proxy agent for other repeaters.
- Supports two addresses per port, allowing for both a physical and DECnet address to be seen and recorded.
- Supports Out-of-Band Management, which provides an SNMP path in addition to normal in-band management by using the Serial Line Internet Protocol (SLIP) through the front-panel serial port on the module, when the module is installed in the Digital MultiStack System, DEChub 90, or as a standalone unit.
- Provides security and statistics capability.

3.2 Repeaters

3.2.9 DECpeater 90C

The DECpeater 90C module is a compact, seven-port repeater that connects PCs and workstations to a ThinWire 802.3/Ethernet LAN. The DECpeater 90C module has six ThinWire ports for connecting Ethernet segments, and a ThinWire port to connect to a coaxial cable Ethernet backbone. Up to 29 stations can be attached to each port.

Figure 3–9 shows the DECpeater 90C network module.

Figure 3–9 DECpeater 90C

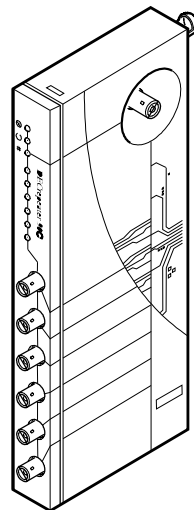

NPG-5245-95F

Platform

This half-height module is used in the:

- Digital MultiStack System
- DEChub 900 MultiSwitch
- DEChub 90
- When used standalone it requires a separate power unit.

Protocol

Ethernet 802.3

3.2 Repeaters

Media

Six 10Base2 ports (BNC coaxial connectors).

LAN Connectivity

- One ThinWire BNC when installed in the Digital MultiStack System
- One backplane ThinWire in a DEChub 900 MultiSwitch.
- One backplane ThinWire when installed in a DEChub 90.
- One ThinWire BNC when installed standalone.

Upgrade Method

Not field upgradeable.

Manageability

- Digital MultiStack System—Requires the DECagent 90, the DECrepeater 90TS, or DECrepeater 90FS as the stack manager for local and remote management.
- DEChub 900 MultiSwitch—Managed through the integral hub management agent.
- DEChub 90—Requires the DECagent 90, the DECrepeater 90TS, or DECrepeater 90FS for local and remote management
- DEChub ONE—Not installable.
- DEChub ONE-MX—Not installable.
- Standalone—Not manageable.

Supported MIBs

- Ethernet MIB (RFC 1398)
- Repeater MIB (RFC 1516)
- Digital Extended Repeater MIB
- MIB II (RFC 1213)

IP Service

Not an IP Services provider.

3.3 Port Switches

3.3 Port Switches

PORTswitch modules are high-density Ethernet modules that support configuration switching on a port group or per-port basis. Per-port configuration switching provides the flexibility to logically group any individual or combination of externally accessible ports to any of six internal LAN segments.

Additionally, using clearVISN management software, any of these six internal Ethernet segments can then be software switched, to specific Ethernet segments on the backplane of the DEChub 900 MultiSwitch. When installed in a DEChub ONE or DEChub ONE-MX the PORTswitch can be configured as a single multisegment standalone product.

Portswitch characteristics are as follows:

- Port switching capability to link a port, or pair of ports, or group of ports to a different LAN segment, as well as the functionality to change those connections under SNMP management control.
- Support for several cable types including twisted-pair (both unshielded and shielded), ThinWire coaxial cable and fiber optic cable. This provides connection to devices that support IEEE 802.3 (i.e., 10Base2, 10BaseT, 10BaseFL/FOIRL).
- Full repeater functionality at the port level.
- Ability to identify malfunctioning ports and automatically segment or restore them to avoid network disruption.
- Provision of per-port statistics, such as total collision per module or number of readable frames per port.
- Secure Ethernet capability that prevents data packets generated by unknown or unauthorized end stations from accessing the network. Authorized station addresses can be set under SNMP management control.
- Eavesdrop protection that is provided by sending data packets to the port of the destination address. All other ports receive scrambled data.
- Intrusion protection, logs violations or disables the port.
- Integral SNMP agent.
- Hot swap capability.
- Front panel LEDs for power, network activity, and port status.
- In-band and out-of-band management capabilities

3.3 Port Switches

- Automatic module self-test at power up.
- One hop when the repeater is connected to a DEChub 900 MultiSwitch flex channel. Two hops when connected to the backplane ThinWire.

The following PORTswitch modules are available.

- PORTswitch 900TP
- PORTswitch 900CP
- PORTswitch 900FP

3.3 Port Switches

3.3.1 PORTswitch 900TP

The PORTswitch 900TP module is a 32 port 802.3 10BaseT port-switching repeater. The module allows per-port switching capability to link a port or group of ports to a LAN segment in DEChub 900 MultiSwitch. Figure 3–10 shows the PORTSwitch 900TP network module.

Figure 3–10 PORTswitch 900TP

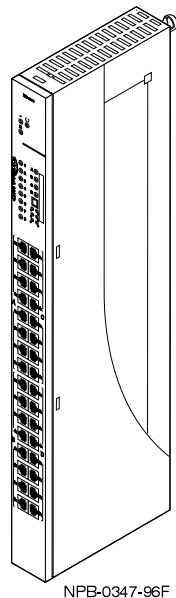

Platform

This full-height module is used in the:

- DEChub 900 MultiSwitch
- DEChub ONE
- DEChub ONE-MX.

Protocol

Ethernet 802.3

Media

Thirty two 8-pin MJ unshielded twisted-pair (UTP) connectors.

3.3 Port Switches

LAN Connectivity

- Each port or group of ports is assignable to one of six flex channels and/or the backplane ThinWire in the DEChub 900 MultiSwitch.
- One AUI when installed in a DEChub ONE or DEChub ONE-MX.

Upgrade Method

- Flash Loader
- TFTP via the Setup port.

Manageability

- Digital MultiStack System—Not installable.
- DEChub 900 MultiSwitch—Managed through the module's built in SNMP agent or through the integral hub management agent.
- DEChub 90—Not installable.
- DEChub ONE—Managed through the module's built in SNMP agent.
- DEChub ONE-MX—Managed through the module's built in SNMP agent.
- Standalone—Not installable.

Supported MIBs

- Ethernet MIB (RFC 1398)
- Repeater MIB (RFC 1516)
- Digital Extended Repeater MIB
- DEChub 900 Public Common MIB
- MIB II (RFC 1213)
- RMON
 - Alarms
 - Events

IP Service

Provides IP Services.

3.3 Port Switches

Features

- Has 32 10BaseT ports that can operate on one LAN or as up to 6 separate port pairs. The port pairs can be assigned independently to any of six backplane LANs (in the DEChub 900 MultiSwitch). Using clearVISN, you can assign the port pairs as redundant links to other devices.
- Has per port security for eavesdropping and intrusion protection.
- Supports up to 13 addresses per port, allowing for both a physical and DECnet address to be seen and recorded.
- Supports Out-of-Band Management, which provides an SNMP path in addition to normal in-band management by using the Serial Line Internet Protocol (SLIP) through the OBM port on the DEChub ONE or DEChub ONE-MX.
- Provides security and statistics capability.
- Supports RMON.
- Provides dual-port redundancy. You can configure any two ports as a redundant pair.

3.3 Port Switches

3.3.2 PORTswitch 900CP

The PORTswitch 900CP module is a 16 port 802.3 10Base2 port-switching repeater. The module allows per-port switching capability to link a port or port group to a LAN segment in a DEChub 900 MultiSwitch. Figure 3–11 shows the PORTswitch 900CP network module.

Figure 3–11 PORTswitch 900CP

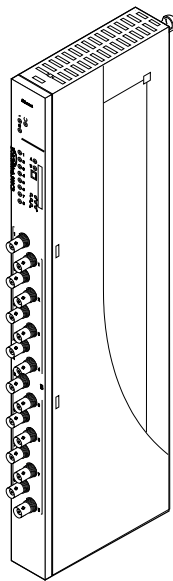

NPB-0348-95F

Platform

This full-height module is used in the:

- DEChub 900 MultiSwitch
- DEChub ONE
- DEChub ONE-MX.

Protocol

Ethernet 802.3

Media

Sixteen 10Base2 ports (BNC coaxial connectors).

3.3 Port Switches

LAN Connectivity

- Each port or group of ports is assignable to one of six flex channels and/or the backplane ThinWire in the DEChub 900 MultiSwitch.
- One AUI when installed in a DEChub ONE or DEChub ONE-MX.

Upgrade Method

- Flash Loader
- TFTP via the Setup port.

Manageability

- Digital MultiStack System—Not installable.
- DEChub 900 MultiSwitch—Managed through the module's built in SNMP agent or through the integral hub management agent.
- DEChub 90—Not installable.
- DEChub ONE—Managed through the module's built in SNMP agent.
- DEChub ONE-MX—Managed through the module's built in SNMP agent.
- Standalone—Not installable.

Supported MIBs

- Ethernet MIB (RFC 1398)
- Repeater MIB (RFC 1516)
- Digital Extended Repeater MIB
- DEChub 900 Public Common MIB
- MIB II (RFC 1213)
- RMON
 - Alarms
 - Events

IP Service

Provides IP Services.

3.3 Port Switches

Features

- Has per port security for eavesdropping and intrusion protection.
- Supports up to 13 addresses per port, allowing for both a physical and DECnet address to be seen and recorded.
- Supports Out-of-Band Management, which provides an SNMP path in addition to normal in-band management by using the Serial Line Internet Protocol (SLIP) through the OBM port on the DEChub ONE or DEChub ONE-MX.
- Provides security and statistics capability.
- Supports RMON.
- Jams unauthorized packets.

3.3 Port Switches

3.3.3 PORTswitch 900FP

The PORTswitch 900FP module is an 802.3 10BaseFL/FOIRL port-switching repeater with 12 fiber ports that can be configured as 6 pairs of redundant ports, 12 individual fiber ports, or in any combination. The module is ideally suited for collapsed fiber backbones, or where redundancy is required. When configured with redundant ports, the PORTswitch 900FP module's automatic failover capability provides additional reliability. Figure 3–12 shows the DECpeater 900FP network module.

Figure 3–12 PORTswitch 900FP

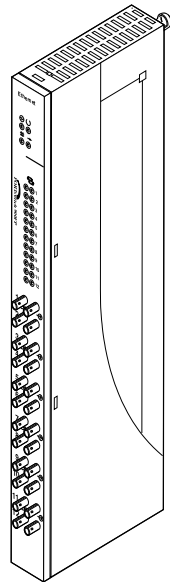

NPB-0405-96F

Platform

This full-height module is used in the:

- DEChub 900 MultiSwitch
- DEChub ONE
- DEChub ONE-MX.

3.3 Port Switches

Protocol

Ethernet 802.3

Media

Twelve ST-type fiber optic connectors.

LAN Connectivity

- Each redundant pair or group is assignable to one of six flex channels and/or the backplane ThinWire in the DEChub 900 MultiSwitch.
- One AUI when installed in a DEChub ONE or DEChub ONE-MX.

Upgrade Method

- Flash Loader
- TFTP via the Setup port.

Manageability

- Digital MultiStack System—Not installable.
- DEChub 900 MultiSwitch—Managed through the module's built in SNMP agent or through the integral hub management agent.
- DEChub 90—Not installable.
- DEChub ONE—Managed through the module's built in SNMP agent.
- DEChub ONE-MX—Managed through the module's built in SNMP agent.
- Standalone—Not installable.

Supported MIBs

- Ethernet MIB (RFC 1398)
- Repeater MIB (RFC 1516)
- Digital Extended Repeater MIB
- DEChub 900 Public Common MIB
- MIB II (RFC 1213)
- RMON
 - Alarms

3.3 Port Switches

- Events

IP Service

Provides IP Services.

Features

- Has twelve fiber-optic ports that can operate on one LAN or as up to 6 separate port pairs. The port pairs can be assigned independently to any of six backplane LANs (in the DEChub 900 MultiSwitch). Using clearVISN, you can assign the port pairs as redundant links to other devices.
- Has per port security for eavesdropping and intrusion protection.
- Supports two addresses per port, allowing for both a physical and DECnet address to be seen and recorded.
- Supports Out-of-Band Management, which provides an SNMP path in addition to normal in-band management by using the Serial Line Internet Protocol (SLIP) through the OBM port on the DEChub ONE or DEChub ONE-MX.
- Provides security and statistics capability.
- Supports RMON.

3.4 Bridges

3.4 Bridges

The DECbridge 90 family of bridges are full-performance IEEE 802.1D compliant Ethernet bridges that connect departmental work groups to larger local area network (LAN) backbones. These bridges keep local network traffic within the work group LAN as they forward traffic that has a destination elsewhere on the backbone. This minimizes work group traffic from impacting overall network performance.

The DECbridge 90 automatically configures itself for operation with any IEEE 802.1D spanning tree compliant bridge. It also automatically learns network addresses in the work group.

The DECbridge 90 filters 29,694 pps, and forwards 14,847 pps, allowing for quick access to local and remote traffic. It supports an unlimited number of nodes on the backbone side, and up to 200 addresses on the work group side.

The DECbridge 90 is also capable of filtering up to 16 protocols in 1 or in both directions. Work group communications stay local, with forwarding occurring only when packets need to be sent out on the network. Network transfer rates run at maximum Ethernet speed (10 Mb/s) enabling the DECbridge 90 to take advantage of the full Ethernet bandwidth.

The following modules are available:

- DECbridge 90
- DECbridge 90FL

3.4 Bridges

3.4.1 DECbridge 90

The DECbridge 90 connects to the backbone using ThinWire Ethernet or AUI transceiver cable. The AUI can support various transmission media such as coaxial and fiber optic cables by use of an optional MAU. Figure 3–13 shows the DECbridge 90 network module.

You can be connected to either the ThinWire or the AUI, but not both simultaneously. The active connection is determined by a slide switch on the front of the module. It also includes a ThinWire 10Base2 port connector (ThinWire BNC) on the side panel (available when installed in the stacking unit or standalone).

NOTE

When used in the hub or stack, the bridge requires a proxy agent. Also, when used in the DEChub 90 the bridge must be installed in slot 7 or 8.

Figure 3–13 DECbridge 90

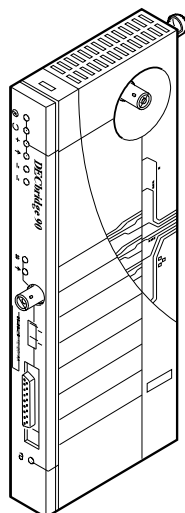

NPB-5246-96F

Platform

This half-height module is used in the:

- Digital MultiStack System

3.4 Bridges

- DEChub 900 MultiSwitch
- DEChub 90
- When used standalone it requires a separate power unit.

Protocol

Ethernet 802.3

Media

One AUI or 10Base2/ThinWire

LAN Connectivity

- One ThinWire BNC or one AUI when installed in the Digital MultiStack System
- One backplane ThinWire when installed in a DEChub 900 MultiSwitch.
- One backplane ThinWire when installed in a DEChub 90.
- One ThinWire BNC or one AUI when standalone.

Upgrade Method

MOP only.

Manageability

- Digital MultiStack System—Requires a proxy agent installed in the stack.
- DEChub 900 MultiSwitch—Requires a proxy agent installed in the chassis.
- DEChub 90—Requires a proxy agent installed in the chassis or on the LAN.
- DEChub ONE—Not installable.
- DEChub ONE-MX—Not installable.
- Standalone—Requires a proxy agent installed on the LAN.

Supported MIBs

- Ethernet MIB (RFC 1398)
- Bridge MIB (RFC 1493)

IP Service

Not an IP Services provider.

3.4 Bridges

Features

- Automatically configures itself for operation with any IEEE 802.1D or Digital spanning tree compliant bridge
- Isolates work group traffic to optimize overall network performance
- Filters 29,694 pps and forwards 14,847 pps, giving work groups high-speed Ethernet bandwidth
- Filters up to 16 protocols in one or in both directions

3.4 Bridges

3.4.2 DECbridge 90FL

The DECbridge 90FL module is a fiber optic version of the DECbridge 90 product. It is a local Ethernet-to-Ethernet 10BaseFL/FOIRL-compliant bridge that combines reliability and high-performance in one compact module. Designed to link a departmental work group to the larger LAN backbone, it features AUI and 10Base FL/FOIRL compliant ST fiber optic backbone connections, and a ThinWire coaxial connector for work groups. Figure 3–14 shows the DECbridge 90FL network module.

Backbone connections are made using ThinWire Ethernet or AUI transceiver cable. The AUI can support various transmission media such as coaxial and fiber optic cables. You can be connected to either the ThinWire or the AUI, but not both simultaneously. The active connection is determined by a slide switch on the front of the module. It also includes a ThinWire 10Base2 port connector (ThinWire BNC) on the side panel (available when installed in the stacking unit).

NOTE

When used in the hub or stack, the bridge requires a proxy agent. Also, when used in the DEChub 90 the bridge must be installed in slot 7 or 8.

Figure 3–14 DECbridge 90FL

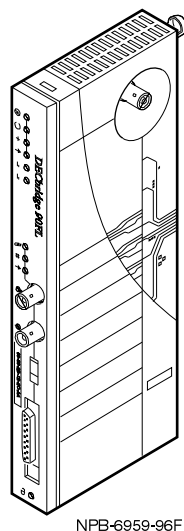

NPB-6959-96F

3.4 Bridges

Platform

This half-height module is used in the:

- Digital MultiStack System
- DEChub 900 MultiSwitch
- DEChub 90.
- When used standalone it requires a separate power unit.

Protocol

Ethernet 802.3

Media

One AUI or 10BaseFL/FOIRL.

LAN Connectivity

- One ThinWire BNC or one AUI when installed in the Digital MultiStack System
- One backplane ThinWire when installed in a DEChub 900 MultiSwitch.
- One backplane ThinWire when installed in a DEChub 90.
- One ThinWire BNC or one AUI when standalone.

Upgrade Method

MOP only.

Manageability

- Digital MultiStack System—Requires a proxy agent installed in the stack.
- DEChub 900 MultiSwitch—Requires a proxy agent installed in the chassis.
- DEChub 90—Requires a proxy agent installed in the chassis or on the LAN.
- DEChub ONE—Not installable.
- DEChub ONE-MX—Not installable.
- Standalone—Requires a proxy agent installed on the LAN.

Supported MIBs

- Ethernet MIB (RFC 1398)
- Bridge MIB (RFC 1493)

3.4 Bridges

IP Service

Not an IP Services provider.

Features

- Automatically configures itself for operation with any IEEE 802.1D or Digital spanning tree compliant bridge
- Isolates work group traffic to optimize overall network performance
- Filters 29,694 pps and forwards 14,847 pps, giving work groups high-speed Ethernet bandwidth
- Filters up to 16 protocols in one or in both directions

3.5 Switches

3.5 Switches

Switches bring the benefits of full performance 802.1D compliant switching to a range of network applications on a variety of levels - the desktop, the department, and the enterprise.

Features

- Provides full 802.1D compliant standards-based switching platforms for data integrity and interoperability.
- Supports full translation of packets between Ethernet and FDDI (IEEE 802.1i) as well as IP packet fragmentation (RFC 791 and 1191) and specialized support for non-translating protocols (IEEE 802.1h).
- Offers user-settable rate limiting of broadcast and multicast packets by address and specific protocol.
- Includes an integral SNMP management agent.

The following modules are available for use in the DEChub platforms or as standalone devices.

- PEs switch 900TX
- DECswitch 900EE (No FDDI)
- DECswitch 900EF
- DECswitch 900FO

NOTE

Appendix A contains details on FDDI Configuration Options.

3.5 Switches

3.5.1 PEswitch 900TX

The PEswitch 900TX product is a full 802.1D compliant, six-port switched (personal, 10 Mb/s) Ethernet to FDDI switch. It combines full-performance switched Ethernet and guaranteed packet integrity with high-performance FDDI server/network connectivity. Figure 3–15 shows the PEswitch 900TX network module.

The ports are:

- Six front panel 10BaseT (8-pin MJ) Ethernet ports with internal crossover. Each port is configurable, via software, to connect to the front panel connector, or alternatively, to one of six internal hub LAN segments.
- An FDDI port that connects through the DEChub 900 MultiSwitch backplane, or the DEChub ONE-MX FDDI modular PMD ports.

The PEswitch 900TX is a fully compliant IEEE 802.1D switch, and supports full performance filtering and forwarding across all ports (that is, Ethernet to Ethernet, Ethernet to FDDI, and FDDI to Ethernet). Full translation of packets between Ethernet and FDDI (IEEE 802.1i), as well as IP packet fragmentation, is also supported. In addition, specialized support is offered for non-translating protocols (IEEE 802.1h) such as AppleTalk and IPX.

Figure 3–15 PEswitch 900TX

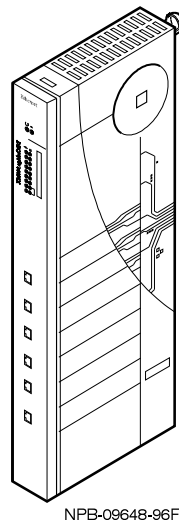

3.5 Switches

Platform

This full-height module is used in the:

- DEChub 900 MultiSwitch
- DEChub ONE
- DEChub ONE-MX.

Protocol

Ethernet 802.3 and FDDI.

Media

Six 8-pin MJ ports (either 100 ohm shielded or unshielded twisted-pair).

LAN Connectivity

- Up to six Ethernet connections on the DEChub 900 MultiSwitch flex channels. One FDDI connection in the DEChub 900 MultiSwitch backplane. Port 3 can be connected to the backplane ThinWire.
- One AUI when installed in a DEChub ONE.
- One AUI and one FDDI (modPMD) when installed in a DEChub ONE-MX.

Upgrade Method

- Flash Loader
- TFTP via the Setup port.

Manageability

- Digital MultiStack System—Not installable.
- DEChub 900 MultiSwitch—Managed through the module's built in SNMP agent or through the integral hub management agent.
- DEChub 90—Not installable.
- DEChub ONE—Managed through the module's built in SNMP agent (if installed, FDDI is unavailable).
- DEChub ONE-MX—Managed through the module's built in SNMP agent.
- Standalone—Not installable.

3.5 Switches

Supported MIBs

- Ethernet MIB (RFC 1398)
- FDDI MIB (RFC 1512)
- Bridge MIB (RFC 1493)
- DEChub 900 Public Common MIB
- MIB II (RFC 1213)

IP Service

Provides IP Services.

Features

- Offers a dedicated 10-Mb channel per user with a connection to a high-speed link (FDDI).
- Supports up to 64 addresses across the six Ethernet ports.
- Delivers aggregate Ethernet forwarding rates in excess of 62,000 packets per second, combined with full-speed filtering for FDDI and all Ethernet ports
- Provides full-performance filtering capabilities (source address, destination address, protocol type). 802.1D compliance ensures packet integrity
- Handles IP fragmentation of large packets from FDDI and 802.3/Ethernet as per RFC-791 (Internet Protocol) and RFC-1191 (Path MTU Discovery).
- Provides translation between FDDI and 802.3/Ethernet frame formats for direct transparent connections, translation of AppleTalk 1 and 2 AARP packets, and handling of “raw 802.3” Novell IPX packets.
- Supports Out-of-Band Management, which provides an SNMP path in addition to normal in-band management by using the Serial Line Internet Protocol (SLIP) through the OBM port on a DEChub ONE or DEChub ONE-MX.

3.5 Switches

3.5.2 DECswitch 900EE

The DECswitch 900EE product is a six-port, SNMP manageable Ethernet backbone switch, providing switching capability between each of the six Ethernets. It supports all the filtering capabilities (source MAC address, destination MAC address, protocol type) as well as providing a large address table (8,000 entries). It is also fully IEEE 802.1D bridge compliant. Figure 3–16 shows the DECswitch 900EE network module.

The DECswitch 900EE module consists of six Ethernets on the front panel (two AUI and four 10BaseT) and provides full-speed switching capability between each of the six Ethernets.

Each port is configurable, via clearVISN software, to connect either to:

- The front panel connector.
- One of six internal DEChub 900 MultiSwitch backplane LAN segments.

Figure 3–16 DECswitch 900EE

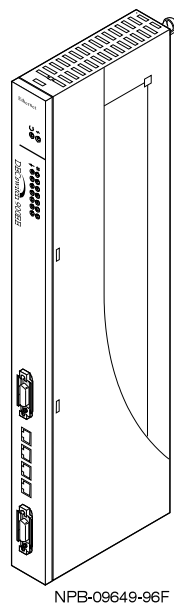

3.5 Switches

Platform

This full-height module is used in the:

- DEChub 900 MultiSwitch
- DEChub ONE
- DEChub ONE-MX.

Protocol

Ethernet 802.3

Media

Two AUI and a four 8-pin MJ.

LAN Connectivity

- Each Ethernet port is independently assignable to either one DEChub 900 Multi-Switch backplane ThinWire or flex channel, or to a dedicated front panel port. Therefore any combination of backplane and front panel connections not exceeding six is allowed. Port 2 only can be connected to the backplane Thin-Wire.
- The Standalone port 3 can be switched to the DEChub ONE AUI.
- The Standalone port 3 can be switched to the DEChub ONE-MX AUI.

Upgrade Method

- Flash Loader.
- TFTP via the Setup port.

Manageability

- Digital MultiStack System—Not installable.
- DEChub 900 MultiSwitch—Managed through the module's built in SNMP agent or through the integral hub management agent.
- DEChub 90—Not installable.
- DEChub ONE—Managed through the module's built in SNMP agent.
- DEChub ONE-MX—Managed through the module's built in SNMP agent.
- Standalone—Not installable.

3.5 Switches

Supported MIBs

- Ethernet MIB (RFC 1398)
- FDDI MIB (RFC 1512)
- Bridge MIB (RFC 1493)
- DEChub 900 Public Common MIB
- MIB II (RFC 1213)

IP Service

Provides IP Services.

Features

- Offers a user-settable rate limiting broadcast and multicast packets by address and specified protocol.
- Supports full performance filtering between all of its six ports, at full Ethernet speeds (14,880 packets /seconds/Ethernet).
- Delivers an aggregate forwarding rate of 45,500 pps (with three ports forwarding and three ports receiving), which is the maximum rate at which six Ethernets can handle traffic.
- Supports Out-of-Band Management, which provides an SNMP path in addition to normal in-band management by using the Serial Line Internet Protocol (SLIP) through the OBM port on a DEChub ONE or DEChub ONE-MX.

3.5 Switches

3.5.3 DECswitch 900EF

The DECswitch 900EF product is a high-throughput, SNMP manageable, multiport network switch solution for linking Ethernet with FDDI LANs. Figure 3–17 shows the DECswitch 900EF network module.

The DECswitch 900EF module is a “line speed” Ethernet to FDDI IEEE 802.1D-compliant switch for the backbone. It has six Ethernet switched ports and one FDDI port, providing full switching capability among each of the six Ethernets and an FDDI LAN. The DECswitch 900EF module has six Ethernet ports on the front panel (two AUI and four 10BaseT), and a DAS FDDI port with fixed ANSI multi-mode MIC connectors.

Each of these ports is configurable, using clearVISN software, to connect either through:

- The front panel ports.
- One of six backplane Ethernet segments of a DEChub 900 MultiSwitch.
- Port 3 can be connected to the backplane ThinWire
- Port 4 can be connected to the network port of a DEChub ONE single-slot chassis
- The FDDI port can be directed to one DEChub 900 MultiSwitch FDDI backplane LAN or the modPMD ports on a DEChub ONE-MX.

The DECswitch 900EF product is a true backbone network switch that supports complete filtering capabilities (source MAC address, destination MAC address, protocol type). It includes a large address table (over 8000 node addresses) and is fully IEEE 802.1D bridge compliant.

3.5 Switches

Figure 3–17 DECswitch 900EF

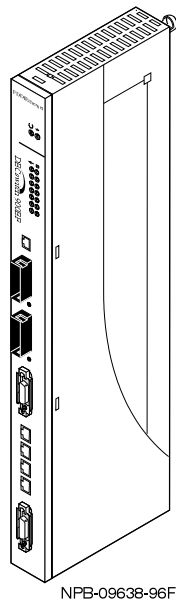

Platform

This full-height module is used in the:

- DEChub 900 MultiSwitch
- DEChub ONE
- DEChub ONE-MX.

Protocol

Ethernet 802.3 and FDDI

Media

Six total Ethernet ports, two AUI and four 8-pin MJ modular jacks (either 100 ohm shielded or unshielded twisted-pair). One DAS FDDI port.

3.5 Switches

LAN Connectivity

- Each Ethernet port is independently assignable to either one DEChub 900 Multi-Switch backplane ThinWire or flex channel, or to a dedicated front panel port. Therefore any combination of backplane and front panel connections not exceeding six is allowed. Port 3 can be switched to the backplane ThinWire
- The Standalone port 4 can be switched to the DEChub ONE AUI.
- The Standalone port 4 can be switched to the DEChub ONE-MX AUI.

Upgrade Method

- Flash Loader
- TFTP via the Setup port.

Manageability

- Digital MultiStack System—Not installable.
- DEChub 900 MultiSwitch—Managed through the module's built in SNMP agent or through the integral hub management agent.
- DEChub 90—Not installable.
- DEChub ONE—Managed through the module's built in SNMP agent.
- DEChub ONE-MX—Managed through the module's built in SNMP agent.
- Standalone—Not installable.

Supported MIBs

- Ethernet MIB (RFC 1398)
- FDDI MIB (RFC 1512)
- Bridge MIB (RFC 1493)
- DEChub 900 Public Common MIB
- MIB II (RFC 1213)
- RMON
 - Statistics
 - History
 - Alarms

3.5 Switches

- Events

IP Service

Provides IP Services.

Features

- Supplies a seven-port bridge, providing six Ethernet to Ethernet ports (2 AUI and four 8-pin MJ modular jacks) plus one DAS FDDI port
- Supports full performance filtering between all of its ports, at full Ethernet speeds (14,880 packets/seconds /Ethernet).
- Provides a minimum filtering rate of more than 460,000 pps on the FDDI port.
- Provides a high-performance forwarding rates with an aggregate output of 62,000 pps.
- Offers a user-setable rate limiting broadcast and multicast packets by address and specified protocol.
- Handles IP fragmentation of large packets from FDDI and 802.3/Ethernet as per RFC-791 (Internet Protocol) and RFC-1191 (Path MTU Discovery).
- Provides translation between FDDI and 802.3/Ethernet frame formats for direct transparent connections, translation of AppleTalk 1 and 2 AARP packets, and handling of “raw 802.3” Novell IPX packets.
- Offers multiple filtering options, including source and destination MAC addresses and protocol
- Supports over 8,000 node addresses
- Supports Out-of-Band Management, which provides an SNMP path in addition to normal in-band management by using the Serial Line Internet Protocol (SLIP) through the OBM port on a DEChub ONE or DEChub ONE-MX.
- Supports RMON.

3.5 Switches

3.5.4 DECswitch 900FO

The DECswitch 900FO six-port Ethernet to FDDI Level 2 switch provides high-performance switching between Ethernet and FDDI networks. The DECswitch 900FO has six front panel fiber optic ST-type ports and one FDDI logical rear backplane port.

Each of the six Ethernet ports is individually software configurable using clearVISN to connect either through:

- The front panel ports.
- One of six backplane Ethernet segments of a DEChub 900 MultiSwitch.
- One of the Ethernets can be configured to connect through the DEChub ONE-MX AUI.

The FDDI logical port must be connected through either the DEChub 900 MultiSwitch backplane or through the physical FDDI ports available on the DEChub ONE-MX.

Figure 3–18 DECswitch 900FO

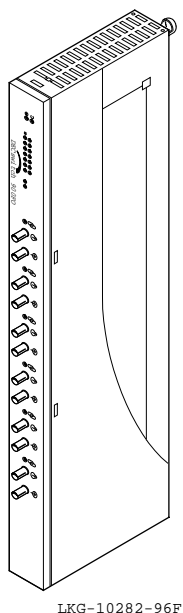

3.5 Switches

Platform

This full-height module is used in the:

- DEChub 900 MultiSwitch
- DEChub ONE
- DEChub ONE-MX.

Protocol

Ethernet 802.3 and FDDI

Media

Six total Ethernet ports (ST-type).

LAN Connectivity

- Each Ethernet port is independently assignable to either one DEChub 900 Multi-Switch backplane ThinWire or flex channel, or to a dedicated front panel port. Therefore any combination of backplane and front panel connections not exceeding six is allowed. One FDDI logical rear backplane port.
- Any one front panel Ethernet port can be switched to the DEChub ONE AUI or to the DEChub ONE-MX AUI. The FDDI port must be connected through the FDDI logical port on the DEChub ONE-MX.

Upgrade Method

- Flash Loader
- TFTP via the Setup port.

Manageability

- Digital MultiStack System—Not installable.
- DEChub 900 MultiSwitch—Managed through the module's built in SNMP agent or through the integral hub management agent.
- DEChub 90—Not installable.
- DEChub ONE—Managed through the module's built in SNMP agent.
- DEChub ONE-MX—Managed through the module's built in SNMP agent.
- Standalone—Not installable.

3.5 Switches

Supported MIBs

- Ethernet MIB (RFC 1398)
- FDDI MIB (RFC 1512)
- Bridge MIB (RFC 1493)
- DEChub 900 Public Common MIB
- MIB II (RFC 1213)
- RMON
 - Statistics
 - History
 - Alarms
 - Events

IP Service

Provides IP Services.

Features

- Switched fiber optic Ethernet to FDDI solution for DEChub 900 MultiSwitch
- Supports VLANs and four basic RMON groups
- Supports clearVISN management that offers simple “point and click” VLAN setup and configuration
- Supports Out-of-Band Management, which provides an SNMP path in addition to normal in-band management by using the Serial Line Internet Protocol (SLIP) through the OBM port on a DEChub ONE or DEChub ONE-MX.
- Supports RMON.

3.6 Routers

3.6 Routers

Digital has an interoperable family of flexible, full- function local, and wide area network multiprotocol routers. The following modules are available for use in the DEChub platforms or as standalone devices.

- DECbrouter 90T1
- DECbrouter 90T2
- DECbrouter 90T2A

3.6.1 DECbrouter 90T1, 90T2, and 90T2A

The DECbrouter 90T provides a multiprotocol internetworking solution for linking small and medium sized Ethernet networks. The module provides full-featured remote routing of the most widely implemented communication protocols. The DECbrouter T also supports concurrent bridging and bidirectional protocol translation between TCP/IP, X.25 and Local Area Transport Environments. Figure 3–19 shows the DECbrouter 90T1 and DECbrouter 90T2 network modules.

The software supports leased line, circuit switched, or packet switched networks such as X.25, Switched Multimegabit Data Service (SMDS) or Frame Relay. The module is well suited for remote applications between branch offices and district or regional offices. Three variants of the DECbrouter 90T are available. They support a wide range of Serial line standards as shown in Table 3–1.

Table 3–1 Comparison of Supported Serial Line Standards

DECbrouter 90T1	DECbrouter 90T2	DECbrouter 90T2A
EIA-530A		EIA-530A
RS-232/V.28	RS-232/V.28	RS-232-V.28
RS-449/RS-422/V.11		RS-449/RS-422/V.11
RS-449/RS-422/V.10		RS-449/RS-422 /V.10
V.35	V.35	
V.36		V.36
X.21 Leased Lines	X.21 Leased Lines	X.21 Leased Lines

3.6 Routers

Figure 3–19 DECrouter 90T1 and DECrouter 90T2

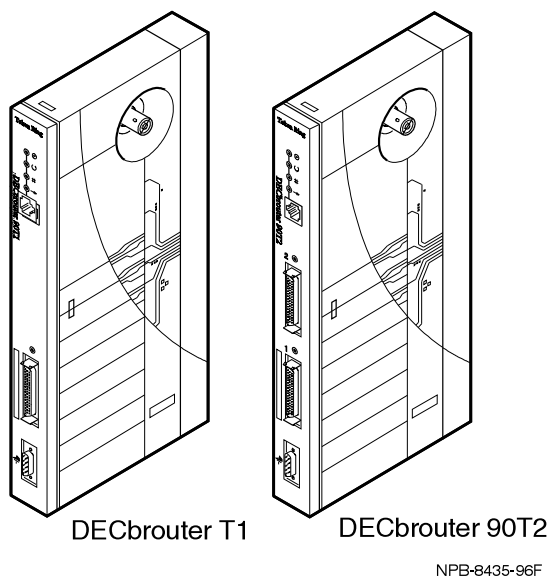

NPB-8435-96F

Platform

This half-height module is used in the:

- Digital MultiStack System
- DEChub 900 MultiSwitch
- DEChub 90
- When used standalone it requires a separate power unit.

Protocol

Ethernet 802.3 and WAN.

Media

One or two “mini-cinch” connectors using a BC12 cable. The cable supports various modem connections.

LAN Connectivity

- One ThinWire BNC when in the Digital MultiStack System.
- One backplane ThinWire when installed in a DEChub 900 MultiSwitch.

3.6 Routers

- One backplane ThinWire when installed in a DEChub 90.
- One ThinWire BNC when standalone.

Upgrade Method

- Flash Loader
- TFTP via the Setup port.

Manageability

- Digital MultiStack System—Managed through the module's built in SNMP agent.
- DEChub 900 MultiSwitch—Managed through the module's built in SNMP agent.
- DEChub 90—Managed through the module's built in SNMP agent.
- DEChub ONE—Not installable.
- DEChub ONE-MX—Not installable.
- Standalone—Managed through the module's built in SNMP agent.

Supported MIBs

- Ethernet MIB (RFC 1398)
- DEChub 900 Public Common MIB

IP Service

Not an IP Services provider.

Features

- Supports IGRP. Provides full interoperability with all installed Cisco router products.
- Provides automatic failover and dial-on-demand to ISDN and switched services.

3.7 Routers

3.7 Routers

Digital has an interoperable family of flexible, full-function local, and wide area network multiprotocol routers. The following two modules are available for use in the DEChub platforms or as a standalone device:

- DECwanrouter 90-802.3/Ethernet to a single 64 Kb/s port.
- DECwanrouter 90EW-802.3/Ethernet to two 64 Kb/s ports.

3.7.1 DECwanrouter 90 and DECwanrouter 90EW

The DECwanrouters 90 and 90EW provide synchronous and asynchronous WAN connections to an Ethernet LAN through a serial line. They offer low-cost, wide-area access for remote sites and branch office LANs with light-to-medium multiprotocol network traffic. The illustration in Figure 3–20 represents both the DECwanrouter 90 and 90EW network modules.

The modules provide connections across a variety of wide-area services including leased lines, dial-up, X.25 and ISDN (using a terminal adapter). In addition to supporting TCP/IP, DECnet, and OSI, the DECwanrouters support Novell IPX.

Figure 3–20 DECwanrouter 90 and 90EW

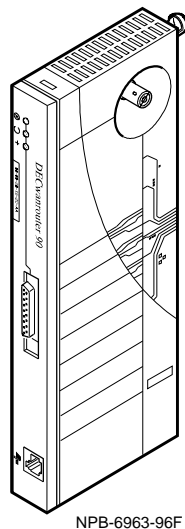

3.7 Routers

Platform

These half-height modules are used in the:

- Digital MultiStack System
- DEChub 900 MultiSwitch
- DEChub 90
- When used standalone, they require a separate power unit.

Protocol

Ethernet 802.3

Media

One “mini-cinch” connector using a BC12 cable.

LAN Connectivity

- One ThinWire BNC when in the Digital MultiStack System.
- One backplane ThinWire when installed in a DEChub 900 MultiSwitch.
- One backplane ThinWire when installed in a DEChub 90.
- One ThinWire BNC when standalone.

Upgrade Method

Not field upgradeable.

Manageability

- Digital MultiStack System—Managed through the module’s built in SNMP agent.
- DEChub 900 MultiSwitch—Managed through the module’s built in SNMP agent.
- DEChub 90—Managed through the module’s built in SNMP agent.
- DEChub ONE—Not installable.
- DEChub ONE-MX—Not installable.
- Standalone—Managed through the module’s built in SNMP agent.

3.7 Routers

Supported MIBs

- DEChub 900 Public Common MIB
- MIB II (RFC 1213)

IP Service

Not IP Services providers.

Features

- Route TCP/IP, Novell IPX, DECnet, and OSI CLNP.
- Support DDCMP, HDLC, ANS X.25 data link protocols.

3.8 Concentrators

3.8 Concentrators

The FDDI concentrators provide for the attachment of devices such as workstations, systems, bridges, routers, or other concentrators to the FDDI network. The following modules are available for use in the DEChub platforms or as standalone device.

- DECconcentrator 900MX
- DECconcentrator 900TH
- DECconcentrator 900FH

NOTE

Appendix A contains details on FDDI Configuration Options.

3.8.1 DECconcentrator 900MX

The DECconcentrator 900MX has six modular Physical Media dependent (modPMDs) FDDI ports on the front panel. The following modPMDs are available:

- Multimode fiber (ANSI MIC and SC connector)
- Single mode fiber (ST and SC connector)
- Unshielded twisted-pair (UTP)

Figure 3–21 shows the DECconcentrator 900MX network module.

3.8 Concentrators

Figure 3–21 DECconcentrator 900MX

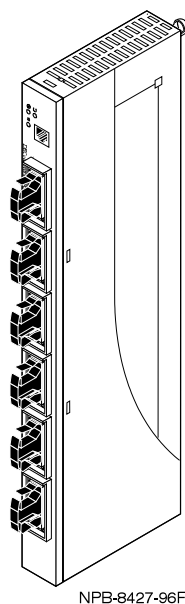

Platform

This full-height module is used in the:

- DEChub 900 MultiSwitch
- DEChub ONE
- DEChub ONE-MX.

Protocol

FDDI

Media

Single-Mode Fiber (SMF), Multi-Mode Fiber (MMF), and Unshielded twisted-pair (UTP).

LAN Connectivity

The module is configurable to connect either through:

- The front panel ports.

3.8 Concentrators

- Two backplane FDDI ports on the DEChub 900 MultiSwitch.

Upgrade Method

- Flash Loader
- TFTP via the Setup port.

Manageability

- Digital MultiStack System—Not installable.
- DEChub 900 MultiSwitch—Managed through the module's built in SNMP agent or through the integral hub management agent.
- DEChub 90—Not installable.
- DEChub ONE—Managed through the module's built in SNMP agent.
- DEChub ONE-MX—Managed through the module's built in SNMP agent.
- Standalone—Not installable.

Supported MIBs

- FDDI MIB (RFC 1512)
- DEChub 900 Public Common MIB
- MIB II (RFC 1213)

IP Service

Provides IP Services.

Features

- Can connect directly to a dual ring or a tree in a hub backplane.
- Provides flexible modular media options.
- Offers maximum configuration flexibility with eight total ports; four are software configurable as FDDI A, B, M, or S ports.
- Contains an optical bypass port (OBR) for use with OBP relays.
- Supports Out-of-Band Management, which provides an SNMP path in addition to normal in-band management by using the Serial Line Internet Protocol (SLIP) through the OBM port on a DEChub ONE or DEChub ONE-MX.

3.8 Concentrators

3.8.2 DECconcentrator 900TH

The DECconcentrator 900TH has fourteen FDDI ports on the front panel. Twelve ports are fixed Unshielded twisted-pair (UTP). Two ports are Physical Media dependent (modPMDs). The following modPMDs are available:

- Multimode fiber (ANSI MIC and SC connector)
- Single mode fiber (ST and SC connector)
- Unshielded twisted-pair (UTP)

NOTE

Refer to Appendix A for details on FDDI configuration options for the module.

Figure 3–22 shows the DECconcentrator 900TH network module.

Figure 3–22 DECconcentrator 900TH

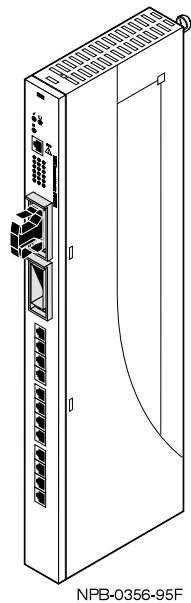

3.8 Concentrators

Platform

This full-height module is used in the:

- DEChub 900 MultiSwitch
- DEChub ONE
- DEChub ONE-MX.

Protocol

FDDI

Media

Two modPMDs and twelve Unshielded twisted-pair (UTP).

LAN Connectivity

The module is configurable to connect either through:

- The front panel ports.
- Two backplane FDDI ports on the DEChub 900 MultiSwitch.

Upgrade Method

- Flash Loader
- TFTP via the Setup port.

Manageability

- Digital MultiStack System—Not installable.
- DEChub 900 MultiSwitch—Managed through the module's built in SNMP agent or through the integral hub management agent.
- DEChub 90—Not installable.
- DEChub ONE—Managed through the module's built in SNMP agent.
- DEChub ONE-MX—Managed through the module's built in SNMP agent.
- Standalone—Not installable.

3.8 Concentrators

Supported MIBs

- FDDI MIB (RFC 1512)
- DEChub 900 Public Common MIB
- MIB II (RFC 1213)

IP Service

Provides IP Services.

Features

- Can connect directly to a dual ring or to a tree in a hub backplane.
- Provides flexible modular media options.
- Offers maximum configuration flexibility with sixteen total ports; two are software configurable as FDDI A, B, M, or S ports.
- Contains an optical bypass port (OBR) for use with OBP relays.
- Supports Out-of-Band Management, which provides an SNMP path in addition to normal in-band management by using the Serial Line Internet Protocol (SLIP) through the OBM port on a DEChub ONE or DEChub ONE-MX.

3.8 Concentrators

3.8.3 DECconcentrator 900FH

The DECconcentrator 900FH has fourteen FDDI ports on the front panel. Twelve ports are fixed Multimode fiber (SC connector). Two ports are Physical Media dependent (modPMDs). The following modPMDs are available:

- Multimode fiber (ANSI MIC and SC connector)
- Single mode fiber (ST and SC connector)
- Unshielded twisted-pair (UTP)

NOTE

Refer to Appendix A, for details on FDDI configuration options for the module.

Figure 3–23 shows the DECconcentrator 900FH network module.

Figure 3–23 DECconcentrator 900FH

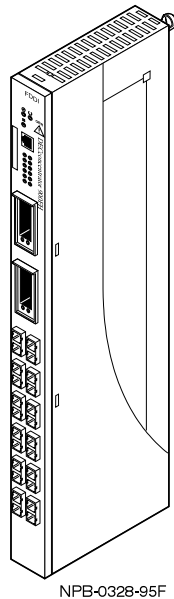

3.8 Concentrators

Platform

This full-height module is used in the:

- DEChub 900 MultiSwitch
- DEChub ONE
- DEChub ONE-MX.

Protocol

FDDI

Media

Two modPMDs and twelve Multi-Mode fiber)

LAN Connectivity

The module is configurable to connect either through:

- The front panel ports.
- Two backplane FDDI ports on the DEChub 900 MultiSwitch.

Upgrade Method

- Flash Loader
- TFTP via the Setup port.

Manageability

- Digital MultiStack System—Not installable.
- DEChub 900 MultiSwitch—Managed through the module's built in SNMP agent or through the integral hub management agent.
- DEChub 90—Not installable.
- DEChub ONE—Managed through the module's built in SNMP agent.
- DEChub ONE-MX—Managed through the module's built in SNMP agent.
- Standalone—Not installable.

Supported MIBs

- FDDI MIB (RFC 1512)
- DEChub 900 Public Common MIB

3.8 Concentrators

- MIB II (RFC 1213)

IP Service

Provides IP Services.

Features

- Can connect directly to a dual ring in a hub backplane.
- Provides flexible modular media options.
- Offers maximum configuration flexibility with six total ports; four are software configurable as FDDI A, B, or M ports.
- Contains an optical bypass port (OBR) for use with OBP relays.
- Supports Out-of-Band Management, which provides an SNMP path in addition to normal in-band management by using the Serial Line Internet Protocol (SLIP) through the OBM port on a DEChub ONE or DEChub ONE-MX.

3.9 Network Access Servers

3.9 Network Access Servers

Network Access Servers connect terminals, printers, or personal computers, to hosts on an Ethernet LAN. Communication servers connect asynchronous devices at speeds up to 115.2 Kb/s to local nodes. They can also provide remote access (dial-in) and modem pool (dial-out) support for remote personal computers.

The following modules are available for use in the DEChub platforms or as standalone devices.

- DECserver 90L+
- DECserver 90TL
- DECserver 90M
- DECserver 900TM
- DECserver 900GM

3.9 Network Access Servers

3.9.1 DECserver 90TL

The DECserver 90TL access server is designed for high-speed asynchronous connections to UNIX, ULTRIX, OpenVMS, DOS, and multivendor network services. This eight-port multisession Telnet/LAT access server offers industry-standard connections at speeds of up to 57.6 Kb/s. It supports TCP/IP, Telnet, LAT, SLIP, CSLIP, and PPP protocols (with a 4 Mb memory upgrade), as well as management systems including SNMP, TSM V1.5, MOP Remote Console, and Telnet Remote Console.

The DECserver 90TL system can be used standalone for small work groups, or combined with other modules in a Digital MultiStack System, DEChub 90 or DEChub 900 MultiSwitch configuration, to connect dozens of terminals, printers, and PCs to large enterprise networks.

The DECserver 90TL provides connections to most modems and printers supporting data leads as well as DSR/DTR control signals. Figure 3–24 shows the DECserver 90TL network module.

Figure 3–24 DECserver 90TL

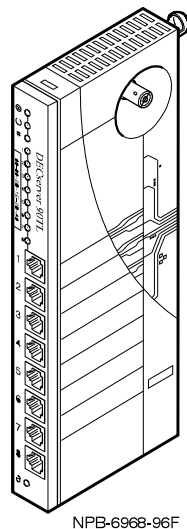

3.9 Network Access Servers

Platform

This half-height module is used in the:

- Digital MultiStack System
- DEChub 900 MultiSwitch
- DEChub 90
- When used standalone it requires a separate power unit.

Protocol

Ethernet 802.3

Media

Eight 8-pin MJ8 connectors.

LAN Connectivity

- One ThinWire BNC when in the Digital MultiStack System.
- One backplane ThinWire when installed in a DEChub 900 MultiSwitch.
- One backplane ThinWire when installed in a DEChub 90.
- One ThinWire BNC when standalone.

Upgrade Method

- RAM only. Downline load at each power up.

Manageability

- Digital MultiStack System—Managed through the module's built in SNMP agent.
- DEChub 900 MultiSwitch—Managed through the module's built in SNMP agent
- DEChub 90—Managed through the module's built in SNMP agent.
- DEChub ONE—Not installable.
- DEChub ONE-MX—Not installable.
- Standalone—Managed through the module's built in SNMP agent.

3.9 Network Access Servers

Supported MIBs

- Ethernet MIB (RFC 1398)
- DEChub 900 Public Common MIB
- MIB II (RFC 1213)
- AppleTalk MIB (RFC 1243)
- Character MIB (RFC 1316)
- RS232-Like MIB (RFC 1317)
- Ethernet-Like MIB (RFC 1284)
- PPP/LCP MIB (RFC 1471)
- IPX MIB (Novell)

IP Service

Not an IP Services provider.

Features

- ThinWire 10Base2 port connector (ThinWire BNC) on the side panel.
- Out-of-Band Management that provides an SNMP path in addition to normal in-band management by using the Serial Line Internet Protocol (SLIP) through the OBM connector on the DEChub 900 MultiSwitch.
- Terminal-to-Host Connectivity
- TD/SMP (Terminal Device/Session Management Protocol)
- ODL (On-Demand Loading Font Protocol)
- DECserver Management Capabilities. Supplied by the following tools:
 - Digital's Terminal Server Manager
 - Telnet Remote Console
 - LAT (local area transport)
 - Simple Network Management Protocol (SNMP)
 - Digital's clearVISN for management of servers in a DEChub environment.
 - MOP (Maintenance Operation Protocol)

3.9 Network Access Servers

- Multiple levels of security for managing and controlling user access
- Accounting—provides event logging of significant user actions
- Terminal-to-Host Connectivity
- 3270 Emulation (with a 4 Mb memory upgrade)
- Command Groups and Menus (with a 4 Mb memory upgrade)

3.9 Network Access Servers

3.9.2 DECserver 90L+

The DECserver 90L+ is an eight-port LAT-only protocol terminal server that connects video terminals, printers, and personal computers, to the Ethernet network environment. It supports up to four sessions per port and provides full 38.4 Kb/s line speeds.

Figure 3–25 DECserver 90L+

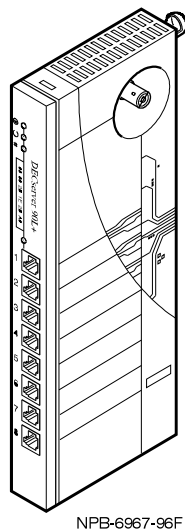

Platform

This half-height module is used in the:

- Digital MultiStack System
- DEChub 900 MultiSwitch
- DEChub 90
- When used standalone it requires a separate power unit.

Protocol

Ethernet 802.3

Media

Eight 6-pin MMJ connectors.

3.9 Network Access Servers

LAN Connectivity

- One ThinWire BNC when in the Digital MultiStack System.
- One backplane ThinWire when installed in a DEChub 900 MultiSwitch.
- One backplane ThinWire when installed in a DEChub 90.
- One ThinWire BNC when standalone.

Upgrade Method

- Not upgradeable.

Manageability

- Digital MultiStack System—Managed through the DECagent 90.
- DEChub 900 MultiSwitch—Managed through the DECagent 90.
- DEChub 90—Managed through the DECagent 90.
- DEChub ONE—Not installable.
- DEChub ONE-MX—Not installable.
- Standalone—Managed through a DECagent 90 somewhere on the same LAN.

Supported MIBs

- Ethernet MIB (RFC 1398)
- DEChub 900 Public Common MIB

IP Service

Not an IP Services provider.

Features

- ThinWire 10Base2 port connector (ThinWire BNC) on the side panel. Terminal-to-Host Connectivity
- TD/SMP (Terminal Device/Session Management Protocol)
- ODL (On-Demand Loading Font Protocol)
- DECserver Management Capabilities. Supplied by the following tools:
 - LAT (local area transport)
 - Simple Network Management Protocol (SNMP)

3.9 Network Access Servers

- Digital's clearVISN for management of servers in a DEChub environment.
- MOP (Maintenance Operation Protocol)
- Multiple levels of security for managing and controlling user access
- Accounting—provides event logging of significant user actions (Not available on the DECserver 90L+.)

3.9 Network Access Servers

3.9.3 DECserver 90M

The DECserver 90M is an enhanced eight-port multiprotocol communications server that supports LAT, TCP/IP, Telnet, SLIP, CSLIP, and PPP.

The module supports up to eight sessions per port and line speeds up to 57.6 Kb/s. The DECserver 90M provides connections to most modems and printers supporting data leads as well as DSR/DTR control signals.

The DECserver 90M also includes a 10BaseT network port in addition to the ThinWire port. Figure 3–26 shows the DECserver 90M network module.

Figure 3–26 DECserver 90M

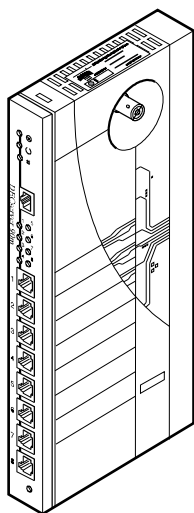

NPG-8459-96F

Platform

This half-height module is used in the:

- Digital MultiStack System
- DEChub 900 MultiSwitch
- DEChub 90
- When used standalone it requires a separate power unit.

3.9 Network Access Servers

Protocol

Ethernet 802.3

Media

Eight 8-pin MJ connectors.

LAN Connectivity

- One ThinWire BNC when in the Digital MultiStack System.
- One backplane ThinWire when installed in a DEChub 900 MultiSwitch.
- One backplane ThinWire when installed in a DEChub 90.
- One ThinWire BNC when standalone.

Upgrade Method

- Reprogrammable via BOOTP/TFTP. Update initiated via a physical console terminal or Telnet remote console. Fall back to downline load at power up.

Manageability

- Digital MultiStack System—Managed through the module's built in SNMP agent.
- DEChub 900 MultiSwitch—Managed through the module's built in SNMP agent.
- DEChub 90—Managed through the module's built in SNMP agent.
- DEChub ONE—Not installable.
- DEChub ONE-MX—Not installable.
- Standalone—Managed through the module's built in SNMP agent.

Supported MIBs

- Ethernet MIB (RFC 1398)
- DEChub 900 Public Common MIB
- MIB II (RFC 1213)
- AppleTalk MIB (RFC 1243)
- Character MIB (RFC 1316)
- RS232-Like MIB (RFC 1317)

3.9 Network Access Servers

- Ethernet-Like MIB (RFC 1284)
- PPP/LCP MIB (RFC 1471)
- IPX MIB (Novell)

IP Service

Provides IP Services (V2.0 or later).

Features

- ThinWire 10Base2 port connector (ThinWire BNC) on the side panel, 10BaseT connector on the front panel.
- Out-of-Band Management that provides an SNMP path in addition to normal in-band management by using the Serial Line Internet Protocol (SLIP) through the OBM connector on the DEChub 900 MultiSwitch.
- Host Multiplexing for remote node or remote control access.
- IP, IPX (Netware), and AppleTalk Connectivity to Ethernet Networks
- 3270 Emulation, Telnet, LAT
- Accounting—provides event logging of significant user actions
- DECserver Management Capabilities—Offered through a variety of tools including:
 - Digital’s Terminal Server Manager
 - Simple Network Management Protocol (SNMP).
 - Digital’s clearVISN for management of servers in a DEChub environment.
 - Telnet Remote Console
 - MOP (Maintenance Operation Protocol)
- Multiple levels of security, for managing and controlling user access, including:
 - Password
 - Kerberos V4
 - SECURID
 - RADIUS

3.9 Network Access Servers

3.9.4 DECserver 900TM

The DECserver 900TM is a 32-port Network Access Server that connects asynchronous devices including terminals, printers, modems, or personal computers to an Ethernet LAN. The module is configured with 32 8-pin MJ connectors and provides software selectable limited modem control.

The DECserver 900TM supports both local and remote access via the DECserver Network Access Software for protocols that include: TCP/IP, Telnet, SLIP, CSLIP, point-to-point protocol (PPP), TN3270, and LAT.

It is a high-performance server capable of supporting 115 Kb/s per port and 215,000 characters per second throughput. Figure 3–27 shows the DECserver 900TM network module.

Figure 3–27 DECserver 900TM

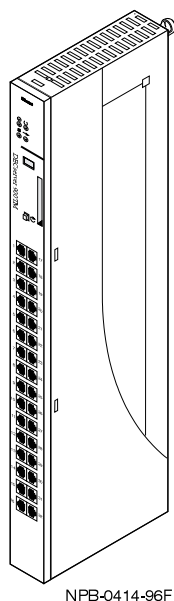

Platform

This full-height module is used in the:

- DEChub 900 MultiSwitch
- DEChub ONE

3.9 Network Access Servers

- DEChub ONE-MX.

Protocol

Ethernet 802.3

Media

Thirty-two 8-pin MJ, either shielded or unshielded twisted-pair.

LAN Connectivity

- When installed in the DEChub 900 MultiSwitch, the module can be connected to the ThinWire Ethernet LAN and/or any one of the six flex channels.
- One AUI when installed in the DEChub ONE or DEChub ONE-MX.

Upgrade Method

- Flash RAM is optional. If present, may be reprogrammed via BOOTP/TFTP. Update initiated via a physical console terminal, Telnet remote console, or DEChub 900 MultiSwitch Setup port. Fall back to downline load at power up.

Manageability

- Digital MultiStack System—Not installable.
- DEChub 900 MultiSwitch—Managed through the module's built in SNMP agent.
- DEChub 90—Not installable.
- DEChub ONE—Managed through the module's built in SNMP agent.
- DEChub ONE-MX—Managed through the module's built in SNMP agent.
- Standalone—Not installable.

Supported MIBs

- Ethernet MIB (RFC 1398)
- DEChub 900 Public Common MIB
- MIB II (RFC 1213)
- AppleTalk MIB (RFC 1243)
- Character MIB (RFC 1316)
- RS232-Like MIB (RFC 1317)

3.9 Network Access Servers

- Ethernet-Like MIB (RFC 1284)
- PPP/LCP MIB (RFC 1471)
- IPX MIB (Novell)

IP Service

Provides IP Services (V2.0 or later).

Features

- Out-of-Band Management that provides an SNMP path in addition to normal in-band management by using the Serial Line Internet Protocol (SLIP) through the OBM connector on the DEChub 900 MultiSwitch.
- Host Multiplexing for remote node or remote control access.
- IP, IPX (Netware), and AppleTalk Connectivity to Ethernet Networks
- 3270 Emulation, Telnet, LAT
- Accounting—provides event logging of significant user actions
- DECserver Management Capabilities—Offered through a variety of tools including:
 - Digital’s Terminal Server Manager
 - Simple Network Management Protocol (SNMP).
 - clearVISN for management of servers in a DEChub environment.
 - Telnet Remote Console
 - MOP (Maintenance Operation Protocol)
- Multiple levels of security, for managing and controlling user access, including:
 - Password
 - Kerberos V4
 - SECURID
 - RADIUS

3.9 Network Access Servers

3.9.5 DECserver 900GM

The DECserver 900GM is a 32-port Network Access Server that connects asynchronous devices including terminals, printers, modems, or personal computers to an Ethernet LAN. The module is configured with four “bulk” connectors (A through D) and provides software selectable limited or full modem control, depending on the cable used.

The DECserver 900GM supports both local and remote access via the DECserver Network Access Software for protocols that include: TCP/IP Telnet, SLIP, CSLIP, point-to-point protocol (PPP), TN3270, and LAT.

It is a high-performance server capable of supporting 115 Kb/s per port and 215,000 characters per second throughput. Figure 3–28 shows the DECserver 900GM network module.

Figure 3–28 DECserver 900GM

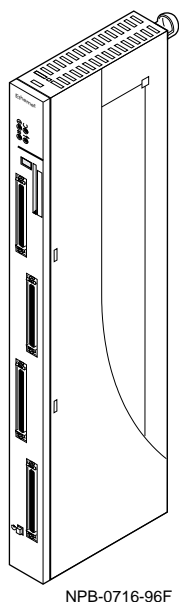

Platform

This full-height module is used in the:

- DEChub 900 MultiSwitch

3.9 Network Access Servers

- DEChub ONE
- DEChub ONE-MX.

Protocol

Ethernet 802.3

Media

Four “bulk” connectors (68 pin high density).

LAN Connectivity

- When installed in the DEChub 900 MultiSwitch, the module can be connected to the ThinWire Ethernet LAN and/or any one of the six flex channels.
- One AUI when installed in the DEChub ONE or DEChub ONE-MX.

Upgrade Method

- Downline load at each power up. Nonvolatile flash memory is optional. If present, may be reprogrammed via BOOTP/TFTP. Update initiated via a physical console terminal, Telnet remote console, or DEChub 900 MultiSwitch Setup port.

Manageability

- Digital MultiStack System—Not installable.
- DEChub 900 MultiSwitch—Managed through the module’s built in SNMP agent.
- DEChub 90—Not installable.
- DEChub ONE—Managed through the module’s built in SNMP agent.
- DEChub ONE-MX—Managed through the module’s built in SNMP agent.
- Standalone—Not installable.

Supported MIBs

- Ethernet MIB (RFC 1398)
- DEChub 900 Public Common MIB
- MIB II (RFC 1213)
- AppleTalk MIB (RFC 1243)

3.9 Network Access Servers

- Character MIB (RFC 1316)
- RS232-Like MIB (RFC 1317)
- Ethernet-Like MIB (RFC 1284)
- PPP/LCP MIB (RFC 1471)
- IPX MIB (Novell)

IP Service

Provides IP Services (using V2.0 or later).

Features

- Optional nonvolatile flash memory using the PCMCIA card slot.
- Out-of-Band Management that provides an SNMP path in addition to normal in-band management by using the Serial Line Internet Protocol (SLIP) through the OBM connector on the DEChub 900 MultiSwitch.
- Host Multiplexing for remote node or remote control access.
- IP, IPX (Netware), and AppleTalk Connectivity to Ethernet Networks
- 3270 Emulation, Telnet, LAT
- Accounting—provides event logging of significant user actions
- DECserver Management Capabilities—Offered through a variety of tools including:
 - Digital’s Terminal Server Manager
 - Simple Network Management Protocol (SNMP).
 - clearVISN for management of servers in a DEChub environment.
 - Telnet Remote Console
 - MOP (Maintenance Operation Protocol)
- Multiple levels of security, for managing and controlling user access, including:
 - Password
 - Kerberos V4
 - SECURID
 - RADIUS

3.10 Management Agents

3.10 Management Agents

A management agent acts as a proxy for devices requiring external SNMP support. The agent responds to SNMP queries on behalf of those devices. The following module is available for use in the DEChub platforms or as standalone device.

- DECagent 90

3.10.1 DECagent 90

The DECagent 90 is a Simple Network Management Protocol (SNMP) proxy agent. Specifically the module provides SNMP support for those modules that do not have an integral agent. These include the DECbridge 90, DECserver 90L+, DECrepeater 90FL, DECrepeater 90C, and the DECrepeater 90T+. Figure 3–29 shows the DECagent 90 network module.

Figure 3–29 DECagent 90

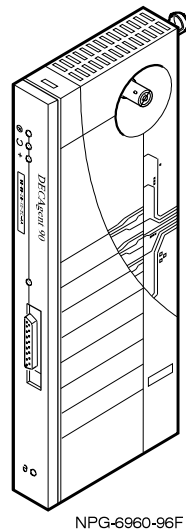

NPG-6960-96F

Platform

This half-height module is used in the:

- Digital MultiStack System
- DEChub 900 MultiSwitch
- DEChub 90

3.10 Management Agents

- When used standalone it requires a separate power unit.

Protocol

Ethernet 802.3

Media

Not applicable

LAN Connectivity

- One ThinWire BNC when installed in the Digital MultiStack System.
- One backplane ThinWire when installed in a DEChub 900 MultiSwitch.
- One backplane ThinWire when installed in a DEChub 90.
- One ThinWire BNC when standalone.

Upgrade Method

- Flash Loader
- TFTP via the Setup port.

Manageability

- Digital MultiStack System—Managed through the module's built in SNMP agent.
- DEChub 900 MultiSwitch—Managed through the module's built in SNMP agent.
- DEChub 90—Managed through the module's built in SNMP agent.
- DEChub ONE—Not installable.
- DEChub ONE-MX—Not installable.
- Standalone—Managed through the module's built in SNMP agent.

Supported MIBs

- DEChub 90 MIB
- Ethernet MIB (RFC 1398)
- DEChub 900 Public Common MIB
- MIB II (RFC 1213)

3.10 Management Agents

IP Service

Not an IP Services provider.

Features

- Management of multiple DEChub 90s with a single management module and selected standalone modules. One DECagent 90 per eight interconnected or 16 standalone DEChub 90 units or 64 standalone modules on the same LAN.
- ThinWire 10Base2 port connector (ThinWire BNC) on the side panel.

3.11 Token Ring

3.11 Token Ring

Digital provides a full range of network modules to create token ring local area networks. These LANs allow the user at the desktop to access the full computing power of the organization through distributed processing. Available network modules provide reliable configuration flexibility for shielded, screened, and unshielded 802.5/Token Ring networks at transfer rates of 4 Mb/s or 16 Mb/s.

The following modules are available for use in the DEChub platforms.

- DECmau 900TH
- DECswitch 900ET
- DECrepeater 900SL
- DECrepeater 900TL
- DECrepeater 900FL

3.11 Token Ring

3.11.1 DECmau 900TH

The DECmau 900TH is an intelligent Token Ring Multistation Access Unit (MAU) that is fully compatible with the IEEE 802.5 standard and IBM Token Ring environments.

The module is designed to support both 4 MB/s and 16 MB/s ring speeds, and provides 24 lobe ports for a star-wired topology. It accommodates 100-ohm shielded twisted-pair and unshielded-twisted-pair cabling using shielded 8-pin MJ connectors and IBM-type data connectors using BN26T cable adapters.

The DECmau 900TH also provides solutions such as automatic speed detection and wrapping. Automatic speed detection allows stations to insert into a ring only if it is at the same ring speed. Automatic ring wrapping maintains ring integrity in case of device or cable failure. Figure 3–30 shows the DECmau 900TH network module.

Figure 3–30 DECmau 900TH

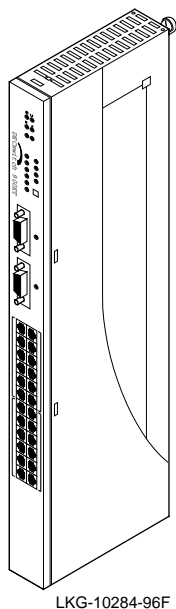

Platform

This full-height module is used in the DEChub 900 MultiSwitch, DEChub ONE, and DEChub ONE-MX.

3.11 Token Ring

Protocol

802.5 Token Ring

Media

Twenty four 8-pin MJ ports, 100-ohm unshielded twisted-pair or shielded twisted-pair cable. Use a balun (BN26T) for connection to 150 ohm shielded twisted-pair.

LAN Connectivity

Connects to either Token Ring 1 or 2.

Upgrade Method

- Flash Loader
- TFTP via the Setup port.

Manageability

- Digital MultiStack System—Not installable.
- DEChub 900 MultiSwitch—Managed through the integral hub management agent.
- DEChub 90—Not installable.
- DEChub ONE —Managed through the integral hub management agent.
- DEChub ONE—Managed through the integral hub management agent.
- Standalone—Not installable.

Supported MIBs

- DEChub 900 Public Common MIB
- DEChub 900 Token Ring Common MIB
- 802.5 MIB
- MIB II (RFC 1213)

IP Service

Not an IP Services provider.

Features

- Provides twenty four station connections.

3.11 Token Ring

- Installs in any token ring network, supporting 4 MB/s or 16 MB/s speeds.
- Eliminates recabling by accepting 100-ohm UTP or STP cable using 8-pin MJ and IBM type data connectors using BN26T cable adapters.
- Ensures reliable connections by repeating and retiming the signal.

3.11 Token Ring

3.11.2 DECswitch 900ET

The DECswitch 900ET interconnects two Token Ring LANs to an Ethernet LAN. The module is designed to support both 4 MB/s and 16 MB/s ring speeds over 100-ohm shielded twisted-pair and unshielded-twisted-pair cabling using shielded 8-pin MJ connectors and IBM-type data connectors.

For Ethernet LANs, both the AUI and 10BaseT can be directly connected to the module. 10Base2 is supported via an external adapter.

Figure 3–31 DECswitch 900ET

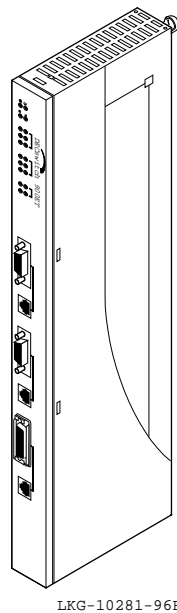

Platform

This full-height module is used in the DEChub 900 MultiSwitch, DEChub ONE, and DEChub ONE-MX.

Protocol

802.5 Token Ring, and Ethernet 802.3

3.11 Token Ring

Media

Two 8-pin MJ ports, 100-ohm unshielded twisted-pair or shielded twisted-pair cable. Use a balun (BN26T) for connection to 150 ohm shielded twisted-pair. One 8-pin MJ port (10BaseT), and one AUI.

LAN Connectivity

- Connects to either Token Ring 1 or 2 in a DEChub 900 MultiSwitch.
- Connects through the AUI in the DEChub ONE.

Upgrade Method

- Flash Loader
- TFTP via the Setup port.

Manageability

- Digital MultiStack System—Not installable.
- DEChub 900 MultiSwitch—Managed through the integral hub management agent.
- DEChub 90—Not installable.
- DEChub ONE—Managed through the integral hub management agent.
- DEChub ONE—Managed through the integral hub management agent.
- Standalone—Not installable.

Supported MIBs

- DEChub 900 Public Common MIB
- DEChub 900 Token Ring Common MIB
- Ethernet MIB (RFC 1398)
- 802.5 MIB
- MIB II (RFC 1213)

IP Service

Not an IP Services provider.

3.11 Token Ring

Features

- Installs in any token ring network, supporting 4 MB/s or 16 MB/s speeds.
- Eliminates recabling by accepting 100-ohm UTP or STP cable using 8-pin MJ and IBM type data connectors using BN26T cable adapters.
- Ensures reliable connections by repeating and retiming the signal

3.11 Token Ring

3.11.3 DECrepeater 900SL

The DECrepeater 900SL is a ring-in/ring-out repeater module, that is used to provide connection to the 802.5 Token Ring trunk wiring. The repeater is configured with two 150-ohm DB9 connections over 150-ohm shielded twisted-pair cable. The repeater allows for extended distances of up to 300 meters. Figure 3–32 shows the DECrepeater 900SL network module.

Figure 3–32 DECrepeater 900SL

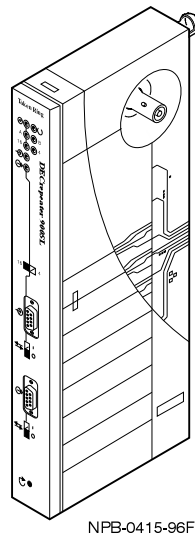

Platform

This half-height module is used in the DEChub 900 MultiSwitch.

Protocol

802.5 Token Ring

Media

Two DB9, 150-ohm shielded twisted-pair cable.

LAN Connectivity

Connects to either Token Ring 1 or 2.

3.11 Token Ring

Upgrade Method

- Flash Loader
- TFTP via the Setup port.

Manageability

- Digital MultiStack System—Not installable.
- DEChub 900 MultiSwitch—Managed through the integral hub management agent.
- DEChub 90—Not installable.
- DEChub ONE—Not installable.
- DEChub ONE-MX—Not installable.
- Standalone—Not installable.

Supported MIBs

- DEChub 900 Public Common MIB
- DEChub 900 Token Ring Common MIB

IP Service

Not an IP Services provider.

Features

- Provides flexibility in token ring design by extending the distances between hubs or Multistation Access Units (MAUs).
- Ensures reliable connections by repeating and retiming the signal
- Offers automatic speed detection to prevent ring failure due to the insertion of incorrectly speed matched repeaters.
- Provides ring autowrap to eliminate LAN failure due to device or cable fault.

3.11 Token Ring

3.11.4 DECrepeater 900TL

The DECrepeater 900TL is a ring in/ring out repeater module, that is used to provide connection to the 802.5 Token Ring trunk wiring. The repeater is configured with two 8-pin MJ ports and supports connections over 100-ohm unshielded twisted-pair (UTP) cable. The repeater allows for extended distances of up to 200 meters. Figure 3–33 shows the DECrepeater 900TL network module.

Figure 3–33 DECrepeater 900TL

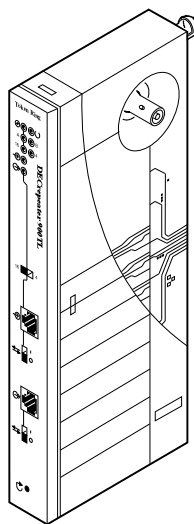

Platform

This half-height module is used in the DEChub 900 MultiSwitch.

Protocol

802.5 Token Ring

Media

Two 8-pin MJ ports, 100-ohm unshielded twisted-pair cable.

LAN Connectivity

Connects to either Token Ring 1 or 2.

3.11 Token Ring

Upgrade Method

- Flash Loader
- TFTP via the Setup port.

Manageability

- Digital MultiStack System—Not installable.
- DEChub 900 MultiSwitch—Managed through the integral hub management agent.
- DEChub 90—Not installable.
- DEChub ONE—Not installable.
- DEChub ONE—Not installable.
- Standalone—Not installable.

Supported MIBs

- DEChub 900 Public Common MIB
- DEChub 900 Token Ring Common MIB
- MIB II (RFC 1213)

IP Service

Not an IP Services provider.

Features

- Provides flexibility in token ring design by extending the distances between hubs or Multistation Access Units (MAUs).
- Ensures reliable connections by repeating and retiming the signal
- Offers automatic speed detection to prevent ring failure due to the insertion of incorrectly speed matched repeaters.
- Provides ring autowrap to eliminate LAN failure due to device or cable fault.

3.11 Token Ring

3.11.5 DECrepeater 900FL

The DECrepeater 900FL is a ring-in/ring-out repeater module, that is used to provide connection to the 802.5 Token Ring trunk wiring. The repeater is configured with two ST type fiber-optic ports on the front panel and two RJ45 8-pin connectors (UTP) on the rear panel. Figure 3–34 shows the DECrepeater 900FL network module.

Figure 3–34 DECrepeater 900FL

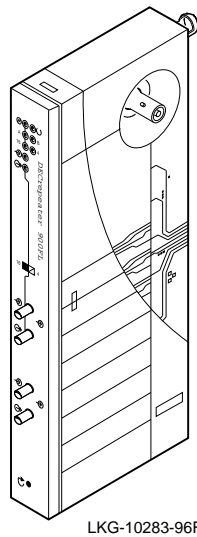

Platform

This half-height module is used in the DEChub 900 MultiSwitch, or as a standalone unit.

Protocol

802.5 Token Ring

Media

Two ST-type fiber optic, two 8-pin MJ 100-ohm unshielded twisted-pair cable.

LAN Connectivity

Connects to either Token Ring 1 or 2.

3.11 Token Ring

Upgrade Method

- Flash Loader
- TFTP via the Setup port.

Manageability

- Digital MultiStack System—Not installable.
- DEChub 900 MultiSwitch—Managed through the integral hub management agent.
- DEChub 90—Not installable.
- DEChub ONE—Not installable.
- DEChub ONE—Not installable.
- Standalone—Managed through the built in SNMP agent.

Supported MIBs

- DEChub 900 Public Common MIB
- DEChub 900 Token Ring Common MIB
- MIB II (RFC 1213)

IP Service

Not an IP Services provider.

Features

- Provides flexibility in token ring design by extending the distances between hubs or Multistation Access Units (MAUs).
- Ensures reliable connections by repeating and retiming the signal
- Offers automatic speed detection to prevent ring failure due to the insertion of incorrectly speed matched repeaters.
- Provides ring autowrap to eliminate LAN failure due to device or cable fault.

3.12 Probes

3.12 Probes

Packet probe modules act as distributed network monitoring performance devices. They implement the Simplified Network Monitoring Protocol (SNMP) Remote Monitoring (RMON) Management Information Base (MIB). Modules are available for Ethernet and Token Ring networks.

The following modules are available for use in the DEChub platforms or as standalone devices.

- DECpacketprobe 90
- DECpacketprobe 900RR

3.12.1 DECpacketprobe 90

The DECpacketprobe 90 operates as a distributed network performance monitoring probe. It is attached to the Ethernet LAN to monitor traffic and error levels. The module implements the Simplified Network Management Protocol (SNMP) Remote Monitoring (RMON) Management Information Base (MIB) for monitoring Ethernet LANs.

Requires RMON Manager. Figure 3–35 shows the DECpacketprobe 90 network module.

Figure 3–35 DECpacketprobe 90

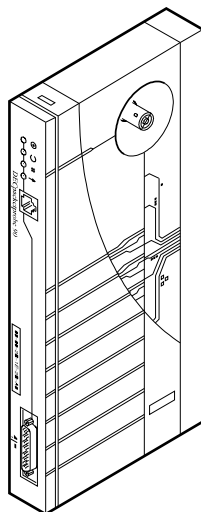

NPB-8433-96F

3.12 Probes

Platform

This half-height module is used in the:

- Digital MultiStack System
- DEChub 900 MultiSwitch
- DEChub 90.
- When used standalone it requires a separate power unit.

Protocol

Ethernet 802.3

Media

One 8-pin MJ connection.

LAN Connectivity

- One ThinWire BNC when installed in the Digital MultiStack System.
- One backplane ThinWire when installed in a DEChub 900 MultiSwitch.
- One backplane ThinWire when installed in a DEChub 90.
- One ThinWire BNC when standalone.

Upgrade Method

- Flash Loader
- TFTP via the Setup port.

Manageability

- Digital MultiStack System—Managed through the module's built in SNMP agent.
- DEChub 900 MultiSwitch—Managed through the module's built in SNMP agent.
- DEChub 90—Managed through the module's built in SNMP agent.
- DEChub ONE—Not installable.
- DEChub ONE-MX—Not installable.
- Standalone—Managed through the module's built in SNMP agent.

3.12 Probes

Supported MIBs

- RMON
- MIB II (RFC 1213)

IP Service

Not an IP Services provider.

Features

- Supports IP Discovery by looking inside the packets to discover which hosts (devices) are speaking IP and associating a network name with an IP address

3.12 Probes

3.12.2 DECpacketprobe 900RR

The DECpacketprobe 900RR operates as a distributed network performance monitoring probe. It is attached to the Token Ring network (4 MB/s or 16 MB/s) to monitor traffic and error levels. The module implements the Simplified Network Management Protocol (SNMP) Remote Monitoring (RMON) Management Information Base (MIB) for monitoring Ethernet LANs.

Requires RMON Manager. Figure 3–36 shows the DECpacketprobe 900RR network module

Figure 3–36 DECpacketprobe 900RR

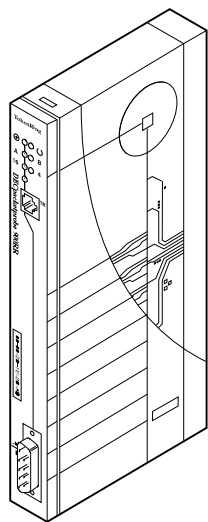

Platform

This half-height module is used in the:

- DEChub 900 MultiSwitch
- When used standalone it requires a separate power unit.

Protocol

Token Ring 802.5

Media

One 8-pin MJ connection.

3.12 Probes

LAN Connectivity

- Connects to Token Ring 1 or 2 when installed in a DEChub 900 MultiSwitch.

Upgrade Method

- Flash Loader
- TFTP via the Setup port.

Manageability

- Digital MultiStack System—Not installable.
- DEChub 900 MultiSwitch—Managed through the module's built in SNMP agent.
- DEChub 90—Not installable.
- DEChub ONE—Not installable.
- DEChub ONE-MX—Not installable.
- Standalone—Not installable.

Supported MIBs

- Token Ring MIB (RFC 1398)
- DEChub 900 Public Common MIB
- MIB II (RFC 1213)

IP Service

Not an IP Services provider.

Features

- Supports IP Discovery by looking inside the packets to discover which hosts (devices) are speaking IP and associating a network name with an IP address.

Management Methods

This chapter describes the methods used to manage DEChub and Digital MultiStack Systems products.

4.1 Introduction

Two methods are available for DEChub and Digital MultiStack System management: in-band management and out-of-band management.

In-band management is the network based method that transports management requests over the LAN. The network management station must be on the same LAN as the module being managed or have access to the module through interconnections within the platform.

Out-of-band management is a network independent method that uses a direct serial connection through the platform's or module's Out-of-Band management (OBM) port. The OBM method allows local or remote access to the hub or module using the Serial Line Internet Protocol (SLIP). SLIP is used for transmitting IP packets across serial lines.

Each method has its own configuration considerations which are described in detail in this chapter.

4.2 In-Band Management

In-band management requires that the platform or module be assigned an In-Band Interface IP address as part of the configuration process. Communication with the network management station is then directed to this IP address. If the platform or module cannot be directly assigned an IP address or does not communicate in the appropriate protocol, then a proxy agent must be assigned.

In band management is provided by native-mode agents, IP services modules, and proxy agents. Modules have their own agents and can provide IP services to hub agents. They are DEChub proxies.

4.2 In-Band Management

A proxy agent is an IP addressable module that communicates in more than one protocol. It communicates with the network management station in its protocol (SNMP), and communicates in other protocols to other devices that cannot communicate directly with the network management station. The device acts as the “proxy” or interpreter between the network management station and these modules.

Management Options

The in-band management options for platforms are:

- Digital MultiStack System
 - Install a proxy agent and use its in-band address to manage all types of modules installed in the stack.
 - If only repeaters are installed in the stack, use a DECrepeater 90FS or DECrepeater 90TS as the proxy agent.
 - Use the IP address assigned to an installed module to manage that module.
- DEChub 90
 - Install a proxy agent and use its in-band address to manage all types of modules installed in the platform.
 - If only repeaters are installed in the platform, use a DECrepeater 90FS or DECrepeater 90TS as the proxy agent.
 - Use the IP address assigned to an installed module that has its own integral agent.
- DEChub 900 MultiSwitch
 - Use the Hub Manager IP address and a module that provides IP Services.
 - Use the IP address assigned to an installed module that has its own integral agent.

The in-band management options for standalone modules are:

- DEChub ONE or DEChub ONE-MX
 - Use the module’s IP address.
- Standalone module
 - Use the module’s IP address.
 - Use a proxy agent on the same network to manage the module.

4.2 In-Band Management

4.2.1 IP Services

The DEChub 900 MultiSwitch Hub Manager cannot communicate with the network directly over the DEChub 900 MultiSwitch serial management bus. For it to communicate with the network it requires a module that can receive and transmit messages over the serial management bus. This is called an IP Services module.

The combination of the IP address and IP Service Module at that assigned slot location establishes the primary In-band management path. If you move the IP Services module to another slot in the hub, you must redefine the location of the IP address.

You can also independently assign an IP address for the module that provides IP services, if you want to manage that module directly. Table 4–1 lists those modules that provide IP Services

Table 4–1 Modules that Provide IP Services

Module	IP Services
Repeaters	
DECrepeater 90T+	No
DECrepeater 90T16	No
DECrepeater 90TS	Yes
DECrepeater 900GM	Yes
DECrepeater 900TM	Yes
DECrepeater 90FA	No
DECrepeater 90FL	No
DECrepeater 90FS	Yes
DECrepeater 90C	No
PORTswitches	
PORTswitch 900TP	Yes
PORTswitch 900CP	Yes

4.2 In-Band Management

Module	IP Services
PORTswitch 900FP	Yes
Bridges	
DECbridge 90	No
DECbridge 90FL	No
Switches	
PEswitch 900TX	Yes
DECswitch 900EE	Yes
DECswitch 900EF	Yes
DECswitch 900FO	Yes
Brouters	
DECbrouter 90T1	No
DECbrouter 90T2	No
DECbrouter 90T2A	No
Routers	
DECwanrouter 90	No
DECwanrouter 90EW	No
Concentrators	
DECconcentrator 900MX	Yes
DECconcentrator 900TH	Yes
DECconcentrator 900FH	Yes
Network Access Servers	
DECserver 90TL	No
DECserver 90L+	No

4.2 In-Band Management

Module	IP Services
DECserver 90M	No
DECserver 900TM	Yes
DECserver 900GM	Yes
Management Agents	
DECagent 90	No
Token Ring	
DECmau 900TH	No
DECswitch 900ET	No
DECrepeater 900SL	No
DECrepeater 900TL	No
DECrepeater 900FL	No
Probes	
DECpacketprobe 90	No
DECpacketprobe 900RR	No

4.2.2 Digital MultiStack System In-Band Management

To manage the Digital MultiStack System, install and designate a module as the stack manager (or proxy agent). Typically the proxy agent is the DECagent 90. For a stack containing all repeaters use the DECrepeater 90TS or DECrepeater 90FS.

4.2.3 DEChub 90 In-Band Management

To manage a DEChub 90, install and designate a DECagent 90 (or a DECrepeater 90TS, or a DECrepeater 90FS for repeater only installations) to act as the proxy agent.

4.2 In-Band Management

4.2.4 DEChub 900 MultiSwitch In-Band Management

To manage the DEChub 900 MultiSwitch, install a module that provides IP services into the chassis. You then assign the In-Band IP address for the Hub Manager to the slot location containing the IP Services module.

4.2.5 DEChub ONE or DEChub ONE-MX In-Band Management

You can directly manage modules that have their own built-in SNMP agent. Modules without integral agents require management by a proxy agent located somewhere on the LAN.

4.2.6 Standalone In-Band Management

You can directly manage modules that have an integral agent. Modules without integral agents require management by a proxy agent located somewhere on the LAN.

4.3 Out-of-Band Management

4.3 Out-of-Band Management

Out-of-band management (OBM) enables you to run any SNMP network management application using the Serial Line Internet Protocol (SLIP), directly at the platform or module without transport over the LAN.

You can use out-of-band management to manage network modules installed in a platform that has a built-in OBM port. Additionally, many network modules have their own OBM port.

Out-of-band management offers the same functionality as In-band management, except that it operates at a lower speed. You must assign an Out-of-Band Interface IP address and set the OBM port speed. The OBM port is a serial interface port that can be connected to an access server, personal computer, or a modem.

You can also manage by establishing a connection from clearVISN to an access server that supports SLIP. If you have an access server in your hub, you can establish a SLIP connection between one of the access server ports and the OBM port.

Options for out-of-band management include.

- Using the platform's Out-of-Band IP address.
- Using the module's Out-of-Band IP address.

Management Options

The out-of-band management options for platforms are:

- Digital MultiStack System
 - Use the OBM port on an installed module.
- DEChub 90
 - Use the OBM port on an installed module.
- DEChub 900 MultiSwitch
 - Use the platform's OBM port.
 - Use the OBM port on an installed module.

4.3 Out-of-Band Management

The out-of-band management options for standalone modules are:

- DEChub ONE or DEChub ONE-MX
 - Use the docking station's OBM port.
 - Use the module's OBM port.
- Standalone module
 - Use the module's OBM port.

4.3.1 Digital MultiStack System Out-of-Band Management

To manage the Digital MultiStack System, use the OBM port of the module acting as the stack manager.

4.3.2 DEChub 90 Out-of-Band Management

To manage a DEChub 90, connect to module acting as the management agent.

4.3.3 DEChub 900 MultiSwitch Out-of-Band Management

To manage the DEChub 900 MultiSwitch, assign the Out-of- Band IP address for the Hub Manager then connect to the OBM port.

Management Tools

This chapter describes the software tools used to for managing products.

5.1 Introduction

The DEChub and Digital MultiStack System products and standalone modules are manageable by any application software that supports native SNMP. Typically, the application software of choice is clearVISN.

clearVISN is an integrated family of software applications for managing a network using policy-based techniques. clearVISN focuses on networking products. Each clearVISN application has a graphical user interface (GUI) and supports Simple Network Management Protocol (SNMP).

clearVISN provides capabilities such as port-based VLAN policies, repeater port security, and configuration-consistency policies. This integrated family of network management capabilities reduces reactive tasks and gives network managers more time for pro-active network management.

clearVISN applications complement, rather than compete with, POLYCENTER Manager on NetView, ManageWORKS, and ServerWORKS, by adding value to applications that manage networking hardware products.

5.2 clearVISN Applications

5.2 clearVISN Applications

The clearVISN applications are listed and described in Table 5–1. The sections following the table describe the applications in detail.

Table 5–1 clearVISN Applications:

Application Name	Purpose
clearVISN Router	Launches two applications: Router Configurator and Router Manager. clearVISN core functionality, for example, the TFTP Server, also resides here.
Router Configurator	Lets you create, modify, and load configuration information for supported Digital bridging routers.
Router Manager	Allows you to monitor performance and faults, collect performance and fault history information, control router software revision levels, manage security, and manage router configurations (for Digital, Bay Networks, Cisco, 3Com and Novell MPR routers).
MultiChassis Manager	Manages the DEChub 90, Digital MultiStack System, DEChub 900 MultiSwitch, GIGAswitch/FDDI, and GIGAswitch/ATM families of devices. MultiChassis Manager displays graphics detailing the actual configuration, and allows users to manage the modules and ports with point-and-click ease.
Stack Manager	Manages the DEChub 90 and Digital MultiStack System of devices. Stack Manager displays graphics detailing the actual configuration of a DEChub 90 or a MultiStack System, and allows users to manage the modules and ports with point-and-click ease.
VLAN Manager	Enables you to segment your network into virtual LANs and then perform changes without physically changing the network cabling or manually reconfiguring the hardware. VLAN Manager uses an off-line database to reconfigure the network.
Flash Loader	Allows you to perform firmware updates on hubs, hub modules, and GIGAswitch/FDDI systems.
Recovery Manager	Lets you save the configuration (or any portion thereof) of a supported network device to a file and later restore that configuration to the same module, or copy it to any device of the same type.

5.2 clearVISN Applications

Application Name	Purpose
RMON Manager	Manages devices that support the Remote Monitoring (RMON) Management Information Base (MIB). RMON Manager uses SNMP to obtain the RMON MIB data from DECpacketprobes and Ethernet switches that have up to full nine group RMON code. It allows you to configure probes and view performance data. It also contains extensive protocol decoding capability.
clearVISN Device Database	Collects real-time information such as traffic graphs and configuration data and provides extensive reports.

NOTE

clearVISN and all its applications run in Windows NT and Windows 95. Stack Manager, MultiChassis Manager, RMON Manager, Router Manager, Flash Loader, and Recovery Manager also run in Windows 3.1.

5.3 Router Configurator

5.3 Router Configurator

The Router Configurator is a software application that enables you to create, modify and load configuration information for supported bridging routers.

The Router Configurator has a Graphical User Interface (GUI). You configure individual bridging routers by entering information on tab pages (screens) for the various router features that you want.

The Router Configurator enables you to do the following tasks:

- Create one or more configurations for a router.
- Modify previously created configurations.
- View a summary file containing details of a given configuration.
- Enter command line interface (CLI) commands to configure features not supported in the Router Configurator.
- Load routers, using Trivial File Transfer Protocol (TFTP).
- Send CLI commands to routers, using Telnet.

5.3.1 Router Configurator Features

The clearVISN Router Configurator allows you to configure a basic set of features and parameters for supported routers. You can configure the following features:

- General system information, including: Hub membership information, SNMP management information, a list of permitted users, BootP relay agent information, and management addresses.
- IP Routing, including OSPF and RIP routing.
- DECnet Phase IV routing.
- DECnet Phase V/OSI routing.
- NetWare IPX routing.
- Bridging, including Transparent (spanning tree) and Source Route bridging.

The Router Configurator only lets you configure the features and parameters supported by the Distributed Routing Software utility QUICK CONFIG. To configure the full set of router features, you need to use the router's CLI commands.

5.3 Router Configurator

5.3.2 Supported Devices

You can use the Router Configurator to configure and load the following bridging routers:

- RouteAbout Access EI
- RouteAbout Access EW
- RouteAbout Access TW
- RouteAbout Central EI
- RouteAbout Central EW
- DECswitch 900 EE (with routing firmware)
- DECswitch 900 EF (with routing firmware)
- DECswitch 900 ET
- DECswitch 900FO

Note

DECnis support will be added in the future.

5.4 Router Manager

5.4 Router Manager

The clearVISN Router Manager application is used for managing a routed network composed of routers from Digital Equipment Corporation, Cisco, Bay Networks, Novell and 3Com. It does this by working with the IETF standard Management Information Base (MIB), and the enterprise-specific extensions defined by these vendors for their router products. clearVISN Router Manager can also manage other routers and bridges in a limited fashion by working with their standard MIB.

Router Manager manages WAN services such as frame relay and X.25 routing protocols such as OSPF, IGRP, and NLSP.

Router Manager displays data from individual devices in pie charts, graphs, and tables that can be exported to an external program. The Device Database application provides extensive reports and exporting capability for collected data. Real-time information including traffic graphs, configuration data, network path information and other pertinent information can also be displayed.

5.4.1 Router Manager Features

The Router Manager provides the following features:

- Security Management
 - Allows users to modify community names
 - Security login for multiple levels of user privileges
- Fault Monitoring
 - Monitors router events continuously
 - Monitors protocol stacks for errors
 - Provides real-time alarm notification
 - Allows configurable thresholds
 - Maintains alarm history
 - Displays alarms by level of severity
 - Monitors Ethernet, token ring, FDDI, and bridging

5.4 Router Manager

- Performance Trending
 - Provides protocol specific statistics for IPX, IP and AppleTalk protocols in real-time graphs
 - Provides system utilization statistics
 - Maintains performance history
 - Supports data exportation to spreadsheets
- Configuration Management
 - Presents graphical overviews of router configurations
 - Provides automated system configuration maintenance
 - Maintains configuration history
- Version Control
 - Allows for management of software versions running on the routers

5.4.2 Supported Devices

The clearVISN Router Manager application supports the following devices:

- Digital DECswitch 900 routers Version 1.0 or higher
- Digital DECnis routers Version 3.1 or higher
- Digital DECbrouters (all versions)
- Digital RouteAbout routers Version 1.0 or higher
- Bay Networks routers Version 5.x, and Version 7.x or higher
- Cisco routers Version 8.2 or higher
- 3Com routers Version 6.2 or higher
- Novell MPR routing software Version 2.11 or higher

5.5 MultiChassis Manager

5.5 MultiChassis Manager

MultiChassis Manager is a flexible, network configuration and management application that features a graphical user interface (GUI). MultiChassis Manager manages 90-series and 900-series network modules, in hubs or standalone, the DEChub 900 MultiSwitch, the GIGAswitch/FDDI system, and the GIGAswitch/ATM system.

To communicate configuration and management commands to network modules, MultiChassis Manager sends Simple Network Management Protocol (SNMP) commands to SNMP management agents in the network modules or in the hub itself.

5.5.1 MultiChassis Manager Features

Use MultiChassis Manager software to:

- View the status and activity of network modules and ports
- Configure LANs on the DEChub 900 MultiSwitch backplane
- Monitor the flow and accuracy of network data
- Configure network modules
- View RMON and other utilization and performance Statistics and History Groups
- Set up filters on the GIGAswitch/FDDI
- Set up hunt groups on the GIGAswitch /FDDI
- Set up Permanent Virtual Circuits (PVCs) on the GIGAswitch/ATM

5.5.2 Supported Devices

The MultiChassis Manager application allows you to manage:

- Standalone 90-series modules
- Network modules installed in a DEChub 90
- Network modules installed in a DEChub 900 MultiSwitch
- Standalone modules installed in DEChub ONE
- Standalone modules installed in DEChub ONE-MX
- Digital's MultiStack products

5.5 MultiChassis Manager

- GIGAswitch/FDDI systems
- GIGAswitch/ATM systems

5.6 Stack Manager

5.6 Stack Manager

Stack Manager is a flexible, network configuration and management application that features a graphical user interface (GUI). Stack Manager manages 90-series network modules, standalone, in a DEChub 90, or in the Digital MultiStack System.

To communicate configuration and management commands to network modules, Stack Manager sends Simple Network Management Protocol (SNMP) commands to SNMP management agents in the network modules or in the hub itself.

5.6.1 Stack Manager Features

Use Stack Manager software to:

- View the status and activity of network modules and ports
- Monitor the flow and accuracy of network data
- Configure network modules

5.6.2 Supported Devices

The Stack Manager application allows you to manage:

- Standalone 90-series modules
- Network modules installed in a DEChub 90
- Digital's MultiStack products

5.7 VLAN Manager

5.7 VLAN Manager

VLAN Manager is a clearVISN application that runs on the Windows 95 or Windows NT operating system. It enables you to logically segment your network into virtual LANs (VLANs). A virtual LAN is a broadcast domain whose membership is based on logical groupings instead of physical media connections. This means that LAN membership can be defined by users' communication needs to rather than the physical connections of nodes and media. Members of a VLAN can communicate as though they were connected to the same physical LAN.

You use Digital's VLAN-capable switches connected over an FDDI backbone to configure port-based VLANs. Port-based VLANs are collections of switch ports which behave as a single broadcast domain. Digital's port-based VLANs can consist of ports from any switch connected by the FDDI backbone. A single Ethernet port on a switch can only be assigned to one VLAN at a time. However, within one switch each Ethernet port can be assigned to a different VLAN. Thus, not all Ethernet ports on a switch to belong to the same VLAN. All the Ethernet ports across the switches assigned to one VLAN make up that VLAN. Network traffic originating at any one of the ports is forwarded across the FDDI backbone to all the other ports on a particular VLAN. Therefore, membership of a particular VLAN is based solely on access to ports on the switches. Digital's DECswitch 900EF, DECswitch 900FO, PEs switch 900TX switches with V1.6 firmware or later currently support port-based VLANs.

You configure VLANs off-line using VLAN Manager. You then use VLAN Manager, via SNMP, to load the VLAN configuration information into Digital's VLAN-capable switches immediately or at a later time. You can then perform moves, adds, and changes to these VLANs without actually changing the physical network cabling or manually manipulating network switching devices such as hubs or switches. Instead, you simply modify the VLAN configuration that defines the VLANs and reload it to the switches.

VLAN Manager is well suited for use with existing networks as well as networks currently being designed and installed. Applying a VLAN configuration to an existing network does not disrupt communication between users who are not included in the created VLANs. Of course, non-VLAN users cannot communicate with VLAN users, except through a router, just as users on one VLAN cannot communicate with users on another created VLAN. However, communication between non-VLAN users continues just as before. Thus, all non-VLAN users make up a "default" VLAN. For new networks, the network configuration can be entered in a VLAN database and evaluated before actually installing the network hardware.

5.7 VLAN Manager

VLAN Manager also enables you to configure more secure networks because each VLAN is a separate broadcast domain that defines which devices and users receive the broadcast packets.

5.7.1 VLAN Manager Benefits

VLAN Manager enables you to optimize performance, ensure proper levels of security, and dynamically adapt to network changes.

- **Performance:** Since the broadcast and multicast traffic is firewalled within each VLAN, the physical switched network can be continuously expanded to accommodate new users by adding new switches, without the danger of an entire switched LAN becoming overwhelmed by excessive broadcast or multicast traffic. This also significantly reduces the need for router firewalls presently used for the same purpose, the routers being generally either slower or more expensive than switches, and more difficult to manage than switches. In effect, VLANs enable you to do more switching and less routing. However, when you use VLANs, routing is required to implement inter-VLAN traffic for e-mail or other purposes.
- **Configuration Flexibility:** Since VLANs are configured in the switches remotely by the VLAN Manager software, the network configuration management—which is necessary to accommodate user or user group physical moves and changes—is more flexible and cost effective than grouping users into subsets by physical location. With VLANs, no reconfiguration at user stations is required to accommodate the moves. For example, users can be physically moved to any place on a large, switched network and get immediate high-performance access to any VLAN project groups simply by notifying the network manager. This is not possible with hard-wired LANs.
- **Flexible Access Control:** With the network management system (NMS) remotely controlling both the switch access ports and VLAN membership, different levels of secure access to the network can be provided and readily changed by a combination of switch and NMS services.

5.7 VLAN Manager

5.7.2 VLAN Manager Features

Specific features of VLAN Manager are as follows:

- Provides a project-group oriented NMS to configure VLANs on switched networks based on Digital's switching products.
- Operates independently or in conjunction with other network management applications on a common clearVISN management platform.
- Includes a graphical user interface (GUI) that is user-friendly and that simplifies the management of network switching devices.
- Supports both the creation and modification of VLAN databases in GUI and ASCII file format.
- Supports testing and resetting of switches to either clear a configuration or query whether a database is loaded to the switch. This can be done at a network level so that it is not necessary to test/reset each switch.
- Supports creation of VLANs that logically segment the network into separate broadcast/multicast domains. A maximum of 255 VLANs can be created in a VLAN database file.
- Uses packet encapsulation and VLAN tags to direct VLAN traffic on the FDDI trunk to the correct switch and port. Therefore VLANs can extend throughout the network. They are not simply restricted to the module or a hub.
- Supports the aggregation of Members into Groups so that they can be manipulated together.
- Supports moving of Groups and Members from one VLAN to another.
- Automatically creates a default VLAN that contains all switch ports and associated users that are not assigned to a created VLAN. Therefore, implementing VLANs on your network does not disrupt communication between users that are not assigned to a VLAN.
- Uses Microsoft's Open Database Connectivity (ODBC), an interface for accessing data in a heterogeneous environment of relational and non-relational database management systems (DBMS).

5.8 Flash Loader

5.8 Flash Loader

The Flash Loader application allows you to perform firmware upgrades on hubs, hub modules, and the GIGAswitch/FDDI system. The device to be loaded is referred to as the agent.

5.8.1 Flash Loader Features

Flash Loader offers the following features:

- Shows information about an agent
- Loads an agent
- Loads a list of agents
- Edits the file used to load a list of agents
- Sets the maximum time Flash Loader will poll an agent to determine if the load task has completed
- Writes status messages that are returned to a log file

5.8.2 Supported Devices

Flash Loader does not support loading devices using the MOP protocol. Devices using the MOP protocol include the DECbridges 90 and 90FL and the DECagent 90, Version 1.1 or earlier. Flash Loader will not work with such devices.

5.9 Recovery Manager

5.9 Recovery Manager

The Recovery Manager application is used to save the configuration of a supported network device to a file on disk and restore that configuration back to the network device.

The graphical user interface allows you to restore the configuration settings to the same or to a like module.

You can back up and restore an entire hub configuration or a partial hub configuration.

5.9.1 Recovery Manager Features

Recovery Manager offers the following features:

- Operates through a graphical user interface (GUI)
- Saves writable SNMP configuration parameters from a network device to a file
- Restores saved parameters from a file to a network device
- Creates command files to perform backup and restore operations at a later time
- Backs up and restores network devices interactively or from command files
- Modifies backup and restore command files
- Provides on-line help that describes the GUI windows, user tasks and provides troubleshooting information

5.9.2 Entire Hub Configuration

You can use Recovery Manager to back up and restore configurations of entire DEChub 900 hubs, thereby selecting all slots and all parameter subsets in each slot.

A full backup of a hub provides a baseline configuration that can be restored whenever the network has been configured improperly or is in an undesired state. Backups of entire hubs also provide a catalog of network configurations. Once a hub is configured using a network management tool such as MultiChassis Manager, you can use Recovery Manager to back up that configuration and then restore a given configuration from the list of saved configurations already backed up.

Recovery Manager's batch mode (command files) allows you to automate back up and restore operations. You can back up and restore network configurations on a schedule that you choose using Windows NT and Windows 95's scheduling service.

5.9 Recovery Manager

5.9.3 Partial Configuration

Partial backups and restores provide more flexibility and control over networks than do backups and restores of entire hubs. Partial configurations include backups and restores of the following:

- Individual slots or groups of slots

A device failure is an example of when to execute a partial configuration — in this case, to restore saved parameters to the replacement device. Rather than restore the entire hub, you can choose to restore only the slot (or group of slots) from a previously saved backup.

Another example is to restore the configuration of a device to another like device in a different slot in the same hub; this can be compared to using Recovery Manager in a dubbing mode.

- Individual parameter subsets or groups of parameter subsets within each slot

Recovery Manager provides more flexibility by allowing you to backup and restore selected parameter subsets rather than all subsets supported. For example, if you wanted to copy only the address filters from one DECswitch 900 bridge to another in the same hub, leaving the protocol filters and spanning tree parameter subsets intact on the destination bridge, you would select only the address filters subset in a restore operation from the source backup file to the destination slot.

5.9.4 Supported Devices

The following network devices are supported:

- DECbridge 900MX, standalone and in a DEChub 900 MultiSwitch
- DECconcentrator 900, all variations, standalone and in a DEChub 900 MultiSwitch
- DEChub 900 MultiSwitch chassis
- DECmau 900TH, standalone and in a DEChub 900 MultiSwitch
- DECmau 900TL, in a DEChub 900 MultiSwitch with a DECmau 900TH
- DECreeper 90, all variations, in a DEChub MultiSwitch 900 only
- DECreeper 900, all Ethernet variations, standalone and in a DEChub 900 MultiSwitch

5.9 Recovery Manager

- DECrepeater 900FL, 900SL and 900TL (Token Ring) in a DEChub 900 Multi-Switch with a DECmau 900TH
- DECswitch 900EE, 900EF and 900FO standalone and in a DEChub 900 Multi-Switch (non-routing versions only)
- PEs switch 900TX, standalone and in a DEChub 900 MultiSwitch
- PORTswitch 900-series, standalone and in a DEChub 900 MultiSwitch
- RoamAbout Access Point, standalone and in a DEChub 900 MultiSwitch

5.10 RMON Manager

5.10 RMON Manager

RMON Manager is an application for managing devices that support RFC 1757 and RFC 1513, the Remote Network Monitoring Management Information Base (MIB) for Ethernet and Token Ring, respectively.

RMON Manager gathers a wide variety of statistical information about network operation by examining each packet passed on a network segment. Segment statistics are stored in counters within the agent (often called a probe). The counters are continuously updated and reset at powerup.

In addition to statistics, network traffic patterns are captured and stored. You can also capture and examine individual packets or sequences of packets to identify and isolate network operational software or hardware problems.

A typical network consists of multiple network segments with one RMON agent connected to each segment. You can control the module from a centrally located network management station (NMS). The NMS has a user interface that permits you to request and examine data from selected modules. You can have multiple clients performing network diagnostic functions from multiple locations such as primary and secondary network management centers.

NOTE

An RMON agent is a hardware and software device that you attach to a specific network segment. The agent gathers statistical information for that segment and provides a window into the segment that you use to observe and analyze network data.

5.10 RMON Manager

5.10.1 RMON Manager Features

The key benefits of implementing RMON Manager are as follows:

- High network availability for users
- High productivity for network managers

These benefits result from network managers using RMON Manager to:

- Monitor enterprise-wide traffic
- Troubleshoot network problems above the physical layer
- Develop custom monitoring and diagnostic solutions
- View multi-segment or multi-domain traffic concurrently
- Monitor and diagnose remote SNMP devices proactively

6

Configuration Examples

This chapter contains a series of configuration examples.

6.1 Introduction

These configurations are samples of small to moderate sized networks designed using DEChub products:

- Case 1 - Managed 10BaseT Workgroup.
- Case 2 - Small Mixed Media Ethernet Workgroup.
- Case 3 - Multi-Ethernet Hub.
- Case 4 - Multi-Ethernet (Building) Backbone.
- Case 5- Collapsed Fiber Optic (Campus) Ethernet Backbone.
- Case 6- Shared FDDI Backbone.
- Case 7- Switched FDDI Backbone.
- Case 8- Remote Access Using Routers and Access Servers.
- Case 9- Connecting Remote Sites to a Cisco Backbone.

6.2 Case 1: Managed 10BaseT Workgroup

6.2 Case 1: Managed 10BaseT Workgroup

Goal

Design and build a simple workgroup supporting personal computers, servers, and printers in a limited area. The work group is supported by a single fiber optic cable segment from a central site.

Design Requirements

- Thirty-two ports of 10BaseT desktop or server connectivity.
- Device wiring is Unshielded Twisted Pair (UTP).
- Backbone connection is 10BaseFL (fiber optic).
- Network management.

Suggested Configuration

Figure 6–1 shows the sample configuration.

- Platform type: DEChub ONE with fiber optic MAU (for connection to the backbone).
- Network Module: The DECRepeater 900TM provides the required 10Base T ports.
- clearVISN network management software

6.2 Case 1: Managed 10BaseT Workgroup

Figure 6–1 Managed 10BaseT Workgroup

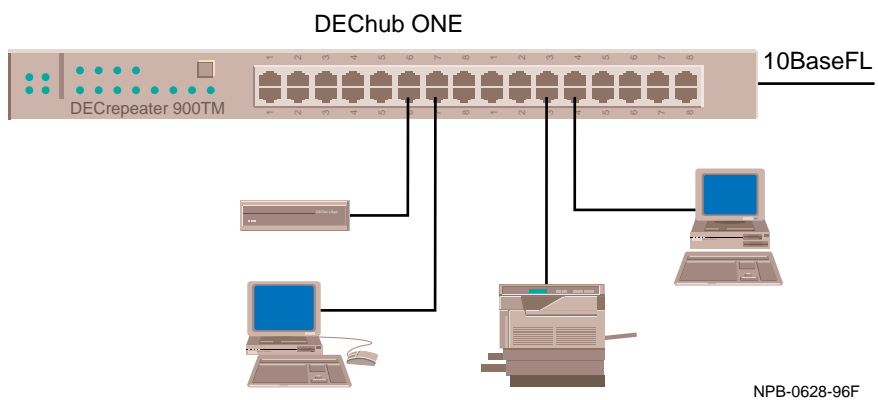

6.3 Case 2: Small Mixed Media Ethernet Workgroup

6.3 Case 2: Small Mixed Media Ethernet Workgroup

Goal

Develop a small managed workgroup environment that supports a mixture of personal computers, workstations, and terminals. The workgroup is one of a series of workgroups off a distributed backbone. The workgroup is located on one floor of a multifloor building and uses a single Ethernet fiber optic cable as the backbone connection.

Design Requirements

- Sixteen ports of 10BaseT desktop or workstation connectivity.
- Six ports of 10Base2 (ThinWire) connectivity to workstations and servers.
- Eight ports of terminal and printer access.
- A bridge to segment the workgroup traffic from the backbone.
- Backbone connection is 10BaseFL (fiber optic).
- Network management

Suggested Configuration

Figure 6–2 shows the sample configuration.

- Platform type: DEChub 90.
- Network Modules:
 - DECbridge 90FL (for connection to the backbone and for workgroup segmentation).
 - DECrepeater 90C (provides the 10Base2 connections).
 - DECrepeater 90T16 (provides the 16 10BaseT ports).
 - DECserver 90TL or DECserver 90M (for terminal support).
 - DECagent 90 (provides proxy service).
- clearVISN network management software

6.3 Case 2: Small Mixed Media Ethernet Workgroup

Figure 6–2 Small Mixed Media Ethernet Workgroup

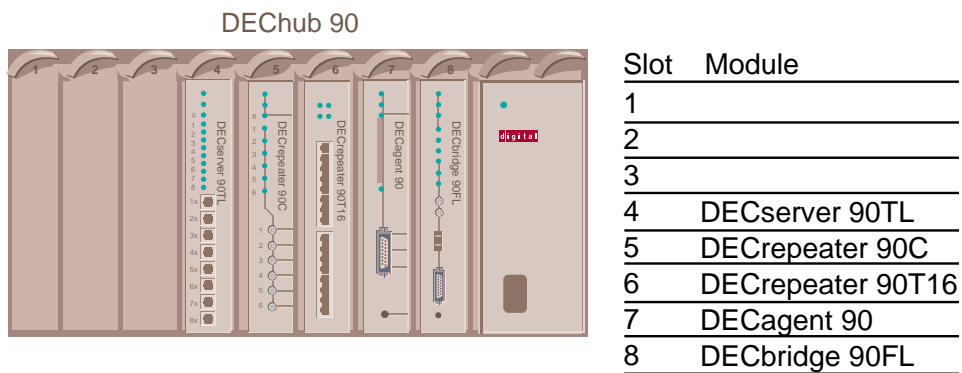

NPB-0629-96F

6.4 Case 3: Multi-Ethernet Hub

6.4 Case 3: Multi-Ethernet Hub

Goal

Provide a collapsed backbone hub to support five separate LANs.

Design Requirements

- Collapsed backbone hub.
- Four redundant Ethernet fiber connections to remote LANs.
- Local Ethernet LAN with:
 - Eight 10BaseT ports
 - Thirty-two asynchronous ports
 - Six 10Base2 (ThinWire) ports
 - A Router with T1 WAN connection
- Full speed bridge support between all five LANs.
- Network management.

Suggested Configuration

- Platform type: Use a DEChub 900 MultiSwitch to support a mixture of half-height and full-height modules and provide the integral management agent.
- Network Modules:
 - DECswitch 900EE (provides for the collapsed Ethernet switching backbone).
 - PORTswitch 900FP (provides for the fiber backbone links between the floors of the building).
 - DECbrouter 90T1 (The WAN connection for the building is made through the DECbrouter 90T1).
 - DECrepeater 90C (provides the six ThinWire ports).
 - DECrepeater 90T16 (provides the eight 10baseT ports with eight additional ports available for expansion).
 - DECserver 900TM (provides the thirty-two asynchronous ports).
- clearVISN network management software.

6.4 Case 3: Multi-Ethernet Hub

Once the hardware has been installed, the clearVISN MultiChassis Manager software is used to configure the hub and the modules.

Options

The extra port on the DECswitch 900EE could be used to provide a separate LAN for connection to:

- A central server.
- The DECserver 900TM.
- The DECbrouter 90T1.

You can substitute the DECrepeater 90T16 with the DECrepeater 900TM or PORTswitch 900TP for higher density and/or more management and configuration control.

Figure 6–3 shows the sample configuration.

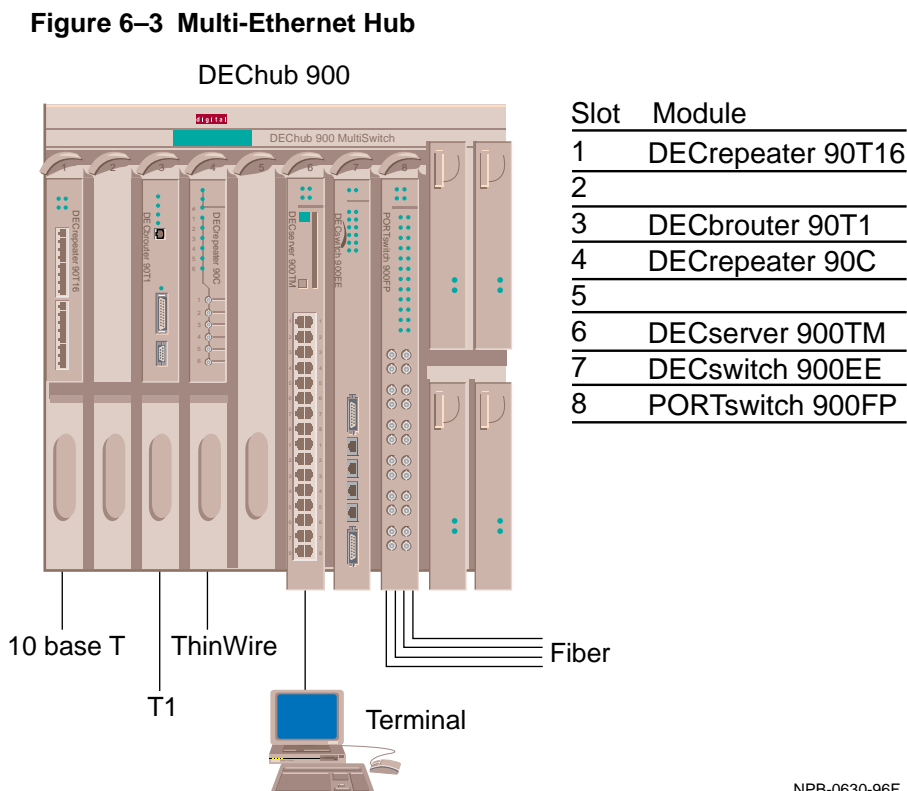

NPB-0630-96F

6.4 Case 3: Multi-Ethernet Hub

All connections between the modules are made under software control using clearVISN MultiChassis Manager. Figure 6–4 shows MultiChassis Manager’s LAN interconnect window for the hub.

Figure 6–4 Multi-Ethernet Hub, LAN Interconnect Window

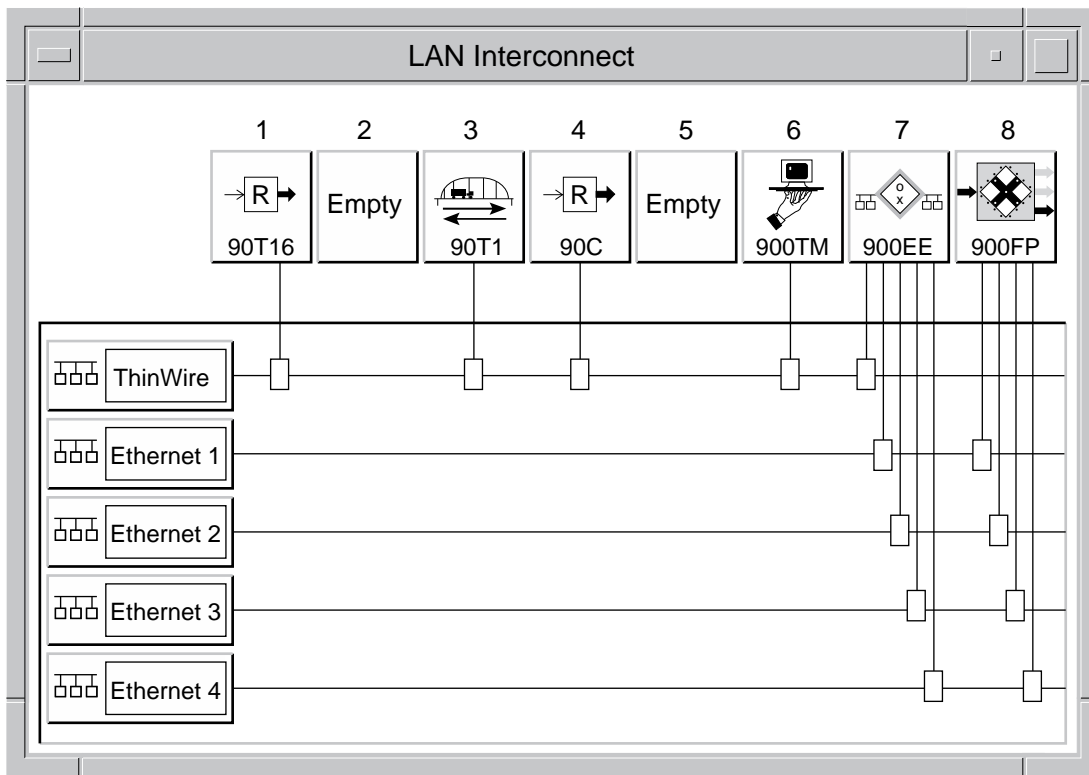

NPB-0636-96F

6.5 Case 4: Multi-Ethernet (Building) Backbone

6.5 Case 4: Multi-Ethernet (Building) Backbone

Goal

Design a multi-Ethernet building network. The network is in a multifloor building and supports several departments.

Design Requirements

- Build LANs with WAN access.
- A centralized department is located on its own floor in the building, with shared services and bridging between all LANs in the building.
- Four different departments, each located in separate floors of the same building.
- New multifunctional teams are formed from the four departments. Users must have access to their own functional department LAN regardless of their location.
- Network management.

This building configuration is similar to Cases 1, 2, and 3 combined.

Suggested Configuration - Central Department:

This configuration is similar to Case 3.

- Platform type: Use a DEChub 900 MultiSwitch to support a mixture of half-height and full-height modules and provide the integral management agent.
- Network Modules:
 - DECswitch 900EE
 - PORTswitch 900FP
 - DECbrouter 90T1
 - DECserver 900TM
 - DECrepeater 90C
 - DECrepeater 90T16

Suggested Configuration - Department 1:

This configuration is similar to Case 2.

- Platform type: DEChub 90
- Network Modules:

6.5 Case 4: Multi-Ethernet (Building) Backbone

- DECrepeater 90FA
- DECagent 90
- DECserver 90TL
- DECrepeater 90T16 (two)
- DECrepeater 90C

Suggested Configuration - Department 2:

This configuration is similar to Case 1.

- Platform type: DEChub ONE
- Network Module:
 - DECrepeater 900TM

Suggested Configuration - Department 3:

This configuration is similar to Case 2.

- Platform type: DEChub 90
- Network Modules:
 - DECrepeater 90FA
 - DECagent 90
 - DECserver 90TL
 - DECrepeater 90T16 (two)
 - DECrepeater 90C

Suggested Configuration - Department 4:

- Platform type: DEChub 900 MultiSwitch
- Network Modules:
 - PORTswitch 900FP
 - DECrepeater 900TM (three)

clearVISN network management software can manage the entire network.

Once the hardware has been installed, the clearVISN MultiChassis Manager software is used to configure the hubs and modules.

Figure 6–5 shows the sample configuration.

6.5 Case 4: Multi-Ethernet (Building) Backbone

Figure 6-5 Multi-Ethernet Backbone Network

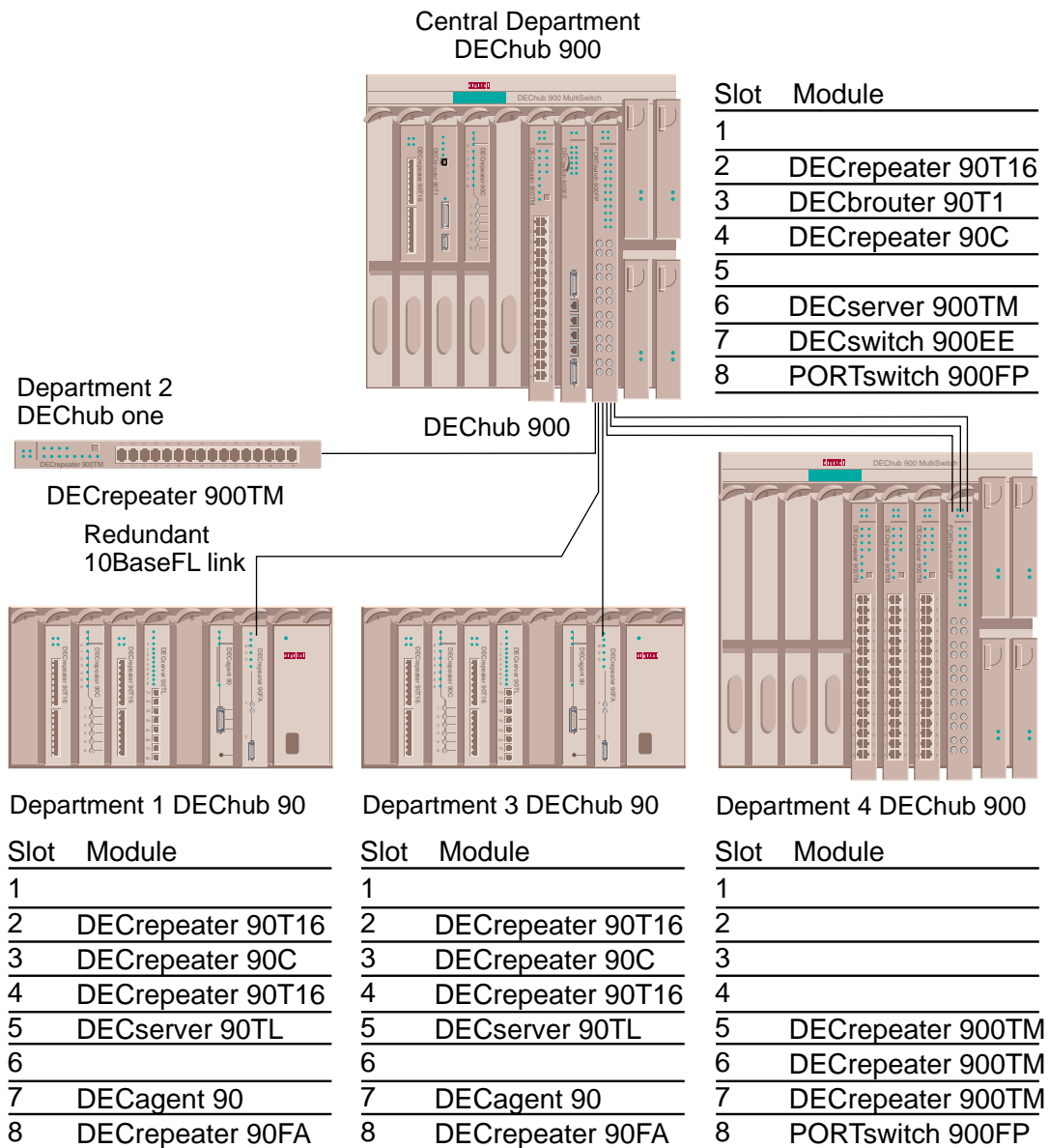

NPB-0631-96F

6.5 Case 4: Multi-Ethernet (Building) Backbone

All connections between the modules are made under software control using clearVISN MultiChassis Manager. Figure 6–6 shows MultiChassis Manager’s LAN interconnect window for the central department.

Figure 6–6 Central Department LAN Interconnect Window

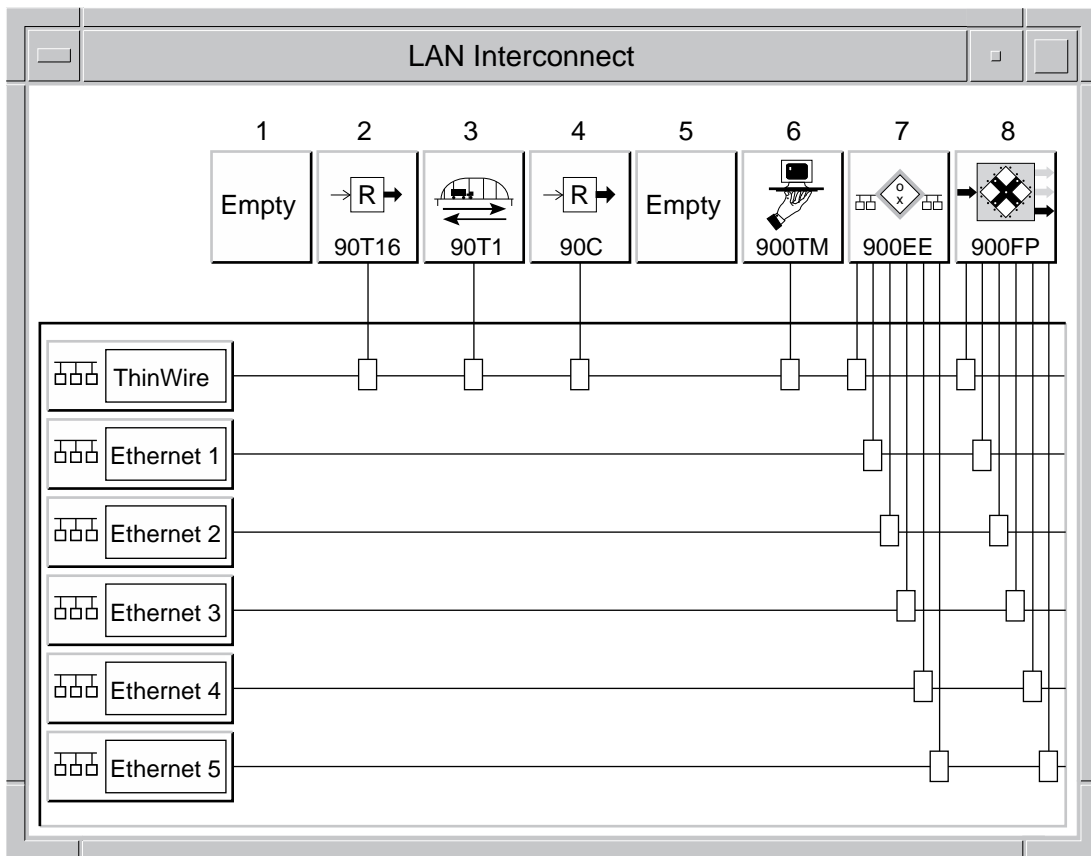

NPB-0677-96F

6.5 Case 4: Multi-Ethernet (Building) Backbone

Figure 6-7 shows MultiChassis Manager's LAN interconnect window for Department 4.

Figure 6-7 Department 4 LAN Interconnect Window

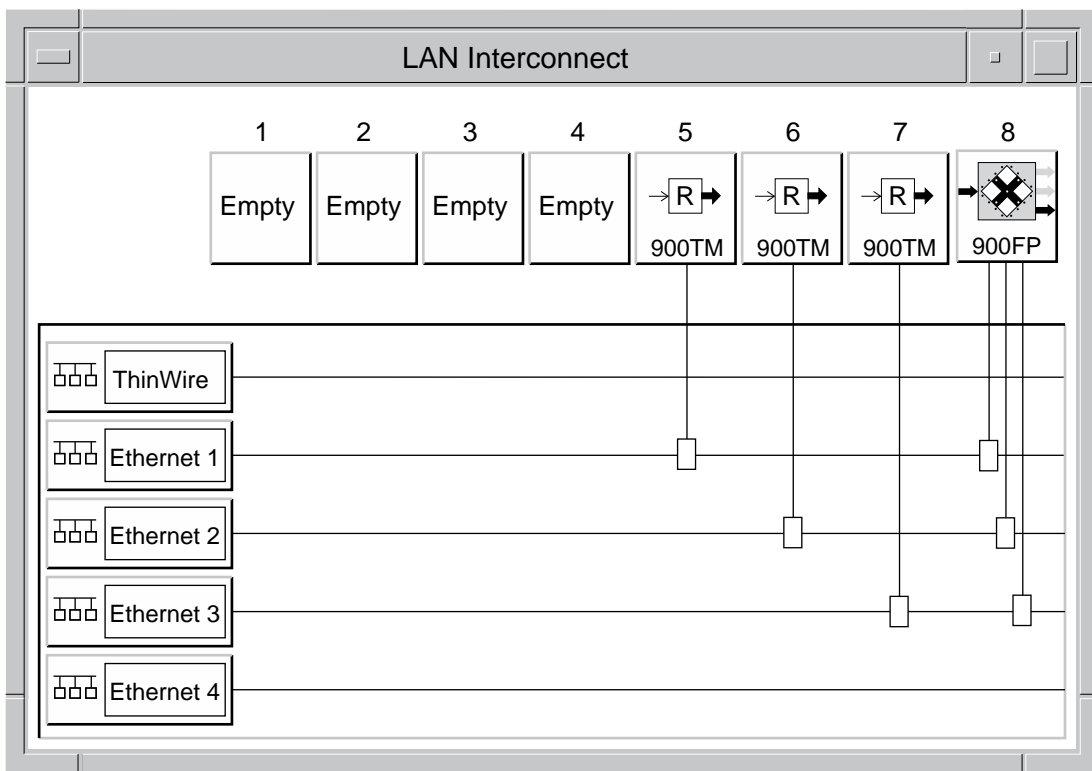

NPB-0638-96F

6.6 Case 5: Collapsed Fiber Optic (Campus) Ethernet Backbone

6.6 Case 5: Collapsed Fiber Optic (Campus) Ethernet Backbone

Goal

Design a collapsed fiber optic campus backbone. This is similar to Case 4, but there is no fiber optic redundancy, allowing the use of a DECswitch 900FO. Groups are spread across multiple buildings. FDDI shared backbone is a likely future migration.

Design Requirements

- A centralized functional department is located in its own building, with shared services and bridging between all LANs in the building.
- A central campus backbone with WAN access.
- A fiber optic campus backbone connection to 3 other buildings.
- Network management.

Suggested Configuration - Central Department:

This configuration is similar to Case 3.

- Platform type: Use a DEChub 900 MultiSwitch to support a mixture of half-height and full-height modules and provide the integral management agent.
- Network Modules:
 - DECswitch 900FO
 - DECbrouter 90T1
 - DECserver 900TM
 - DECrepeater 90C
 - DECrepeater 90T16

Suggested Configuration - Building 1:

This configuration is similar to Case 2.

- Platform type: DEChub 90
- Network Modules:
 - DECrepeater 90FA
 - DECagent 90

6.6 Case 5: Collapsed Fiber Optic (Campus) Ethernet Backbone

- DECserver 90TL
- DECrepeater 90T16 (two)
- DECrepeater 90C

Suggested Configuration - Building 2:

This configuration is similar to Case 1.

- Platform type: DEChub ONE
- Network Module:
 - DECrepeater 900TM

Suggested Configuration - Building 3 (Multi-LAN Building):

- Platform type: DEChub 900 MultiSwitch
- Network Modules:
 - PORTswitch 900FP
 - PORTswitch 900TP (three). These allow load balancing of 96 users across 3 LANs.

clearVISN network management software can manage the entire network.

Once the hardware has been installed, the clearVISN MultiChassis Manager software is used to configure the hubs and modules.

Figure 6–8 shows the sample configuration.

6.6 Case 5: Collapsed Fiber Optic (Campus) Ethernet Backbone

Figure 6–8 Collapsed Fiber Optic Ethernet Backbone

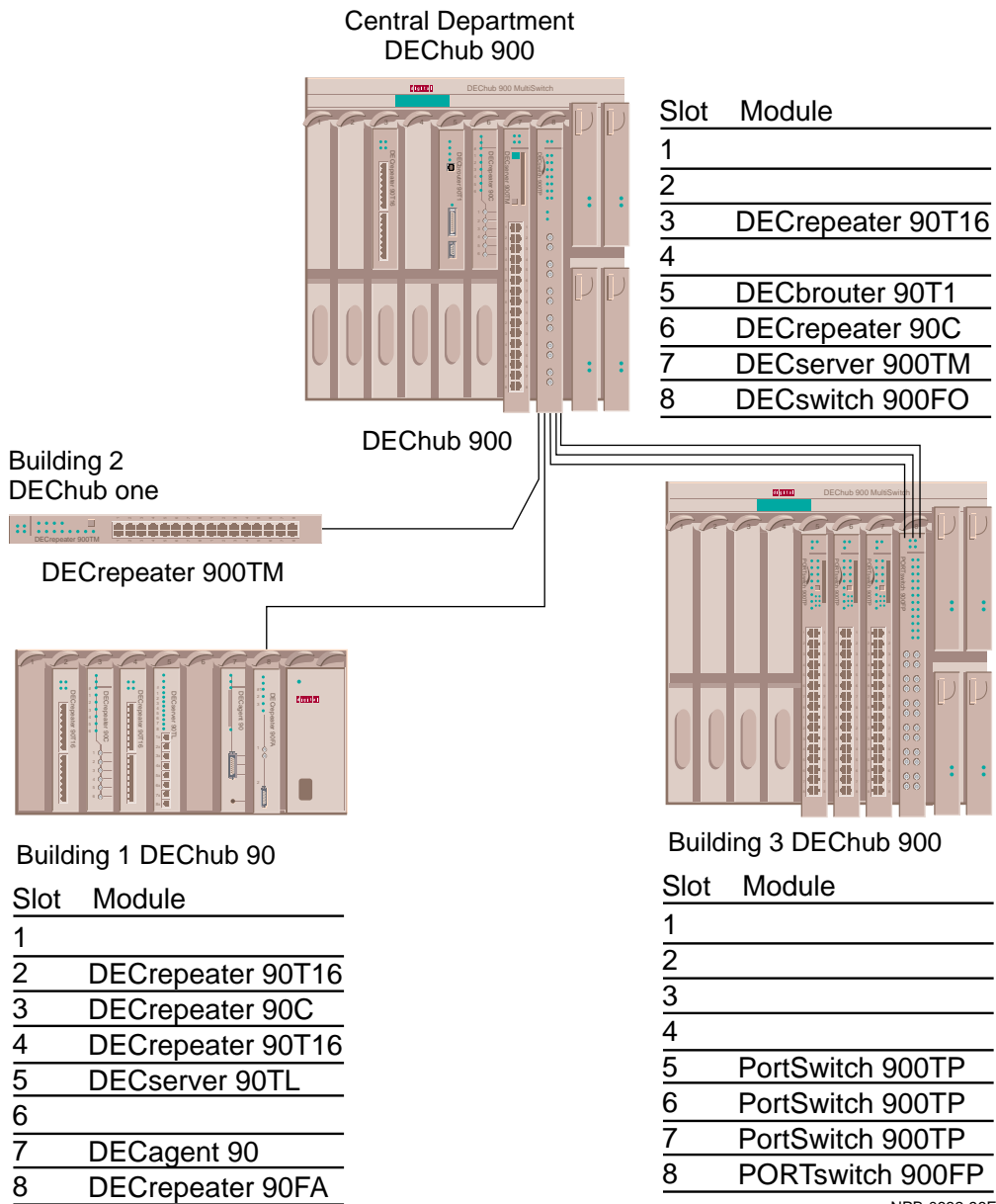

NPB-0632-96F

6.6 Case 5: Collapsed Fiber Optic (Campus) Ethernet Backbone

All connections between the modules are made under software control using clearVISN MultiChassis Manager. Figure 6–9 shows MultiChassis Manager’s LAN interconnect window for the central department.

Figure 6–9 Central Department LAN Interconnect Window

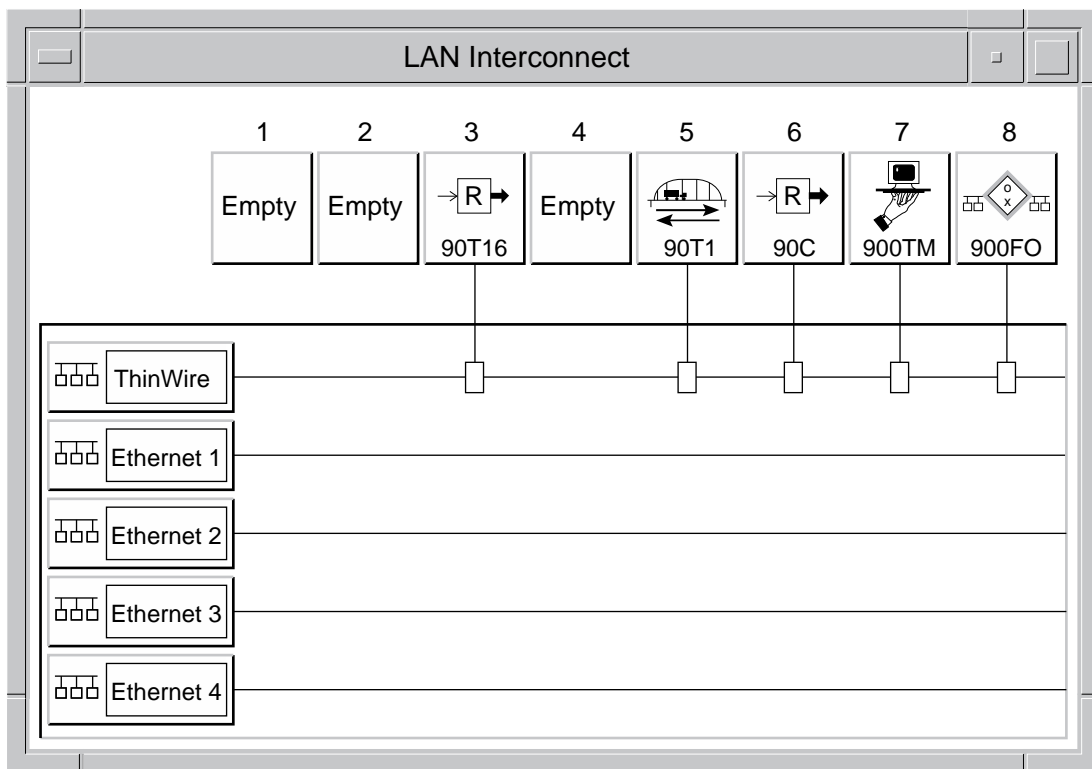

NPB-0639-96F

6.6 Case 5: Collapsed Fiber Optic (Campus) Ethernet Backbone

All connections between the modules are made under software control using clearVISN MultiChassis Manager. Figure 6–10 shows MultiChassis Manager’s LAN interconnect window for building 3.

Figure 6–10 Building 3 LAN Interconnect Window

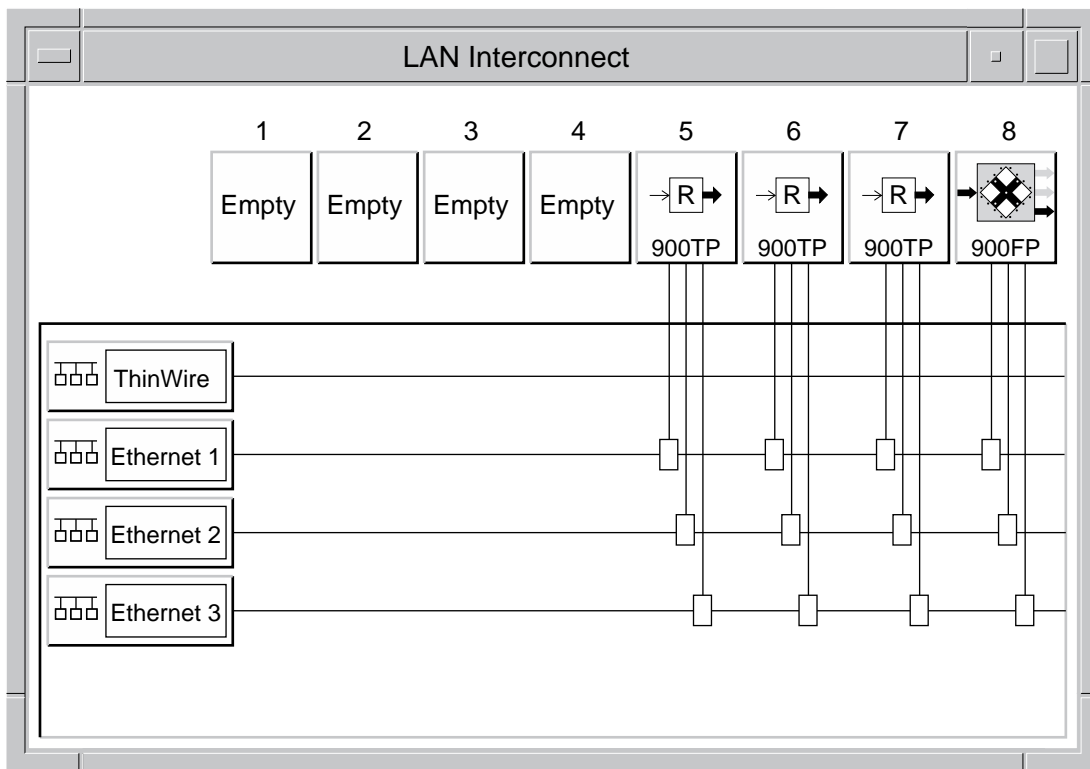

NPB-0640-96F

6.7 Case 6: Shared FDDI Backbone

6.7 Case 6: Shared FDDI Backbone

Goal

Migrate to a larger network with a shared dual FDDI Backbone.

Design Requirements

- Migration of the local shared workgroups of up to 192 users to higher bandwidth.
- Provide FDDI shared network servers.
- Have network management.

Suggested Configuration

- Platform types:
 - DEChub 900 MultiSwitch (three)
- Network Modules:
 - DECswitch 900EF
 - DECconcentrator 900MX. These are only needed for local servers or other FDDI devices.
 - DECrepeater 900TM
- clearVISN network management software.

Once the hardware has been installed, the clearVISN MultiChassis Manager software is used to configure the hubs and modules.

Options:

All DECserver 900TMs can be replaced with PORTswitch 900TPs to allow balancing of the Ethernet loads.

Figure 6–11 shows the hardware implementation.

6.7 Case 6: Shared FDDI Backbone

Figure 6–11 Shared FDDI Backbone

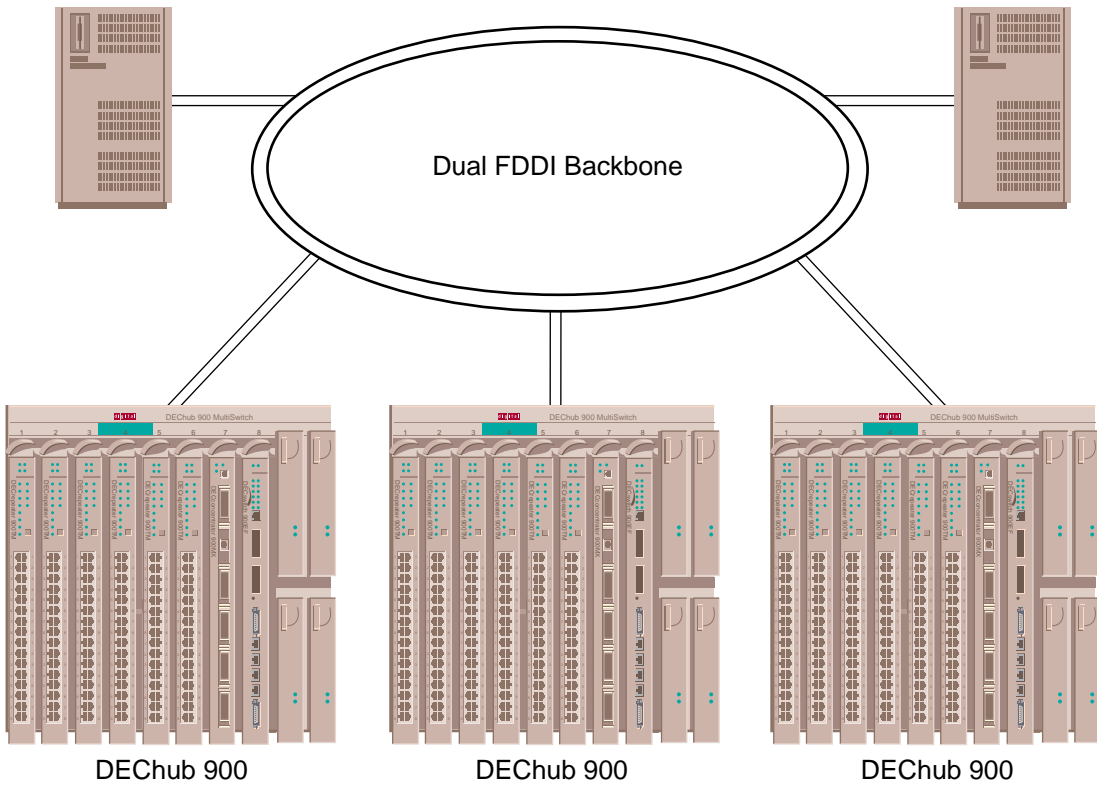

NPB-0633-96F

6.7 Case 6: Shared FDDI Backbone

All connections between the modules are made under software control using clearVISN MultiChassis Manager. Figure 6-12 shows MultiChassis Manager's LAN interconnect window for the workgroup concentrators.

Figure 6-12 Shared FDDI Backbone, LAN Interconnect Window

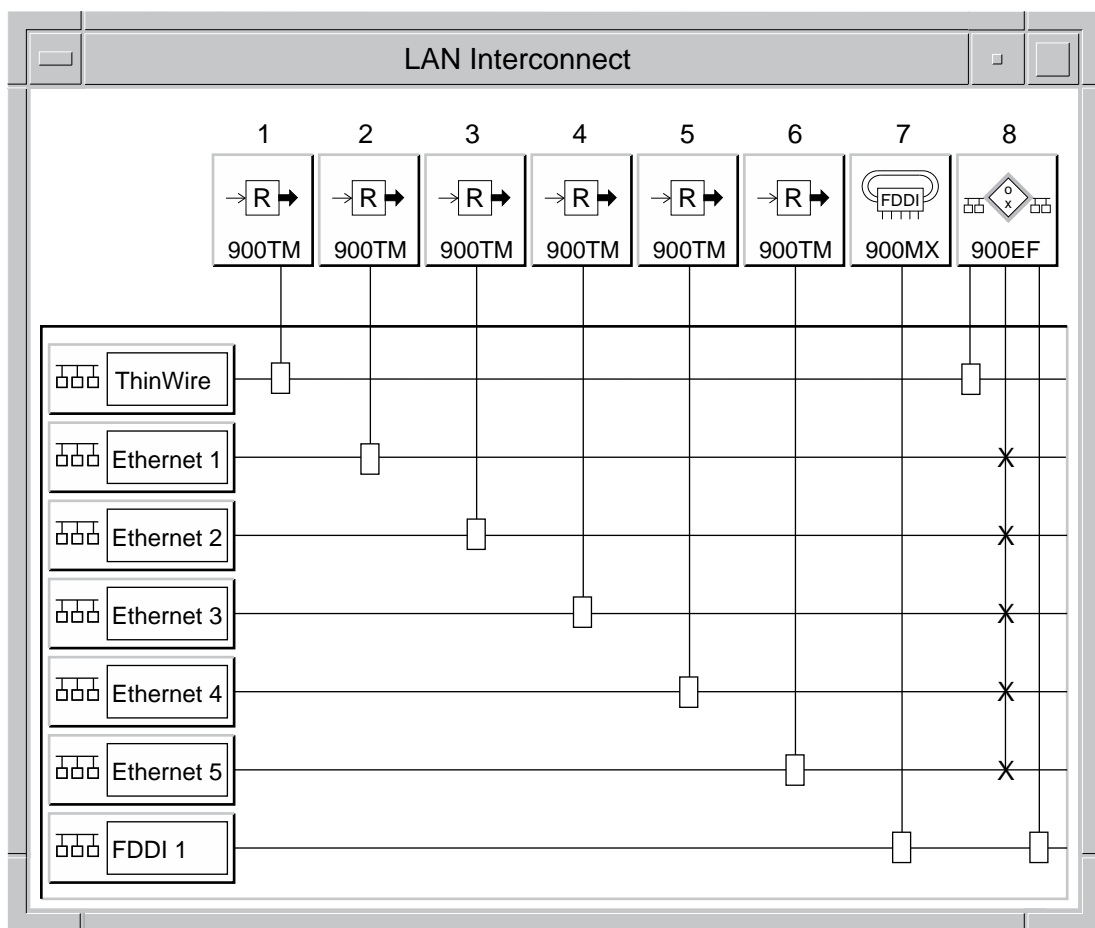

NPB-0670-96F

6.8 Case 7: Switched FDDI Backbone

6.8 Case 7: Switched FDDI Backbone

Goal

Migrate a large shared FDDI backbone to switched FDDI backbone.

Design Requirements

- Migration of the local workgroups to higher bandwidth.
- Provide shared network servers.
- Have network management.

Suggested Configuration

- Platform types:
 - DEChub 900 MultiSwitch (three)
 - GIGAswitch/FDDI
- Network Modules:
 - DECswitch 900EF
 - DECrepeater 900TM
 - DECconcentrator 900MX
- clearVISN network management software.

Once the hardware has been installed, the clearVISN MultiChassis Manager software is used to configure the platforms and modules.

Figure 6–13 shows the hardware implementation.

6.8 Case 7: Switched FDDI Backbone

Figure 6-13 Large Network with Switched Backbone

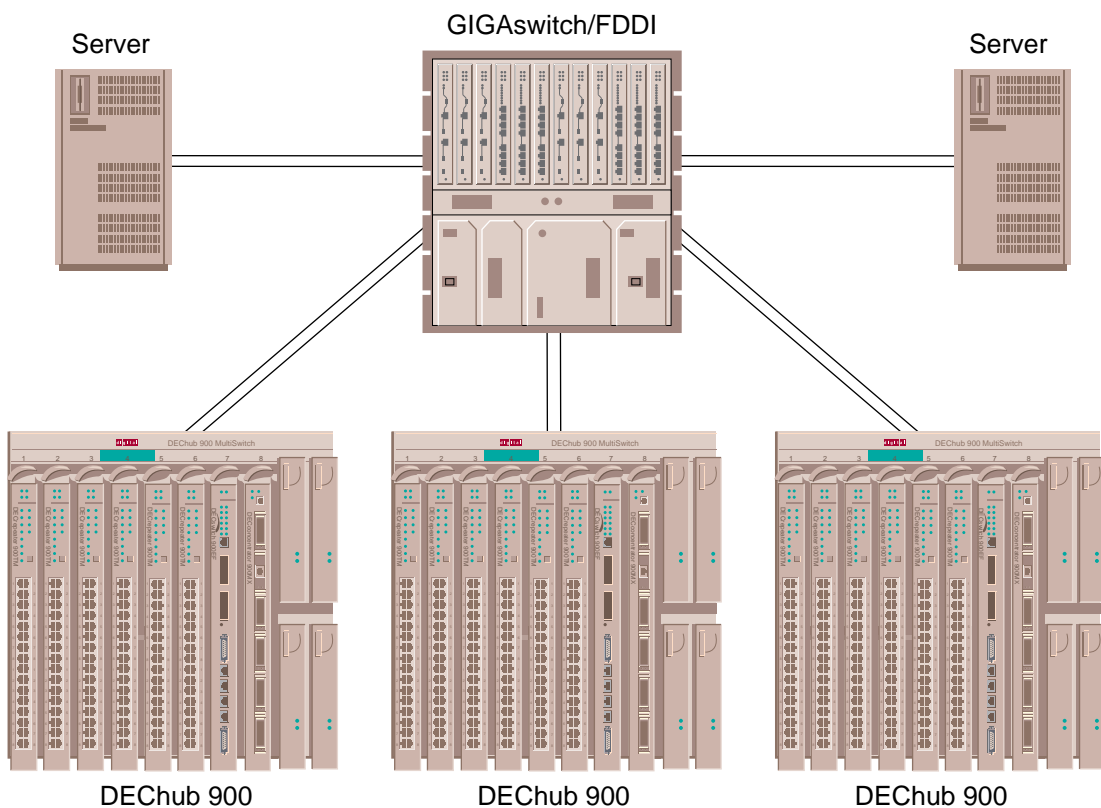

NPB-0634-96F

6.8 Case 7: Switched FDDI Backbone

All connections between the modules are made under software control using clearVISN MultiChassis Manager. Figure 6–14 shows MultiChassis Manager’s LAN interconnect window for the workgroup hubs.

Figure 6–14 Large Network with Switched Backbone, LAN Interconnect Window

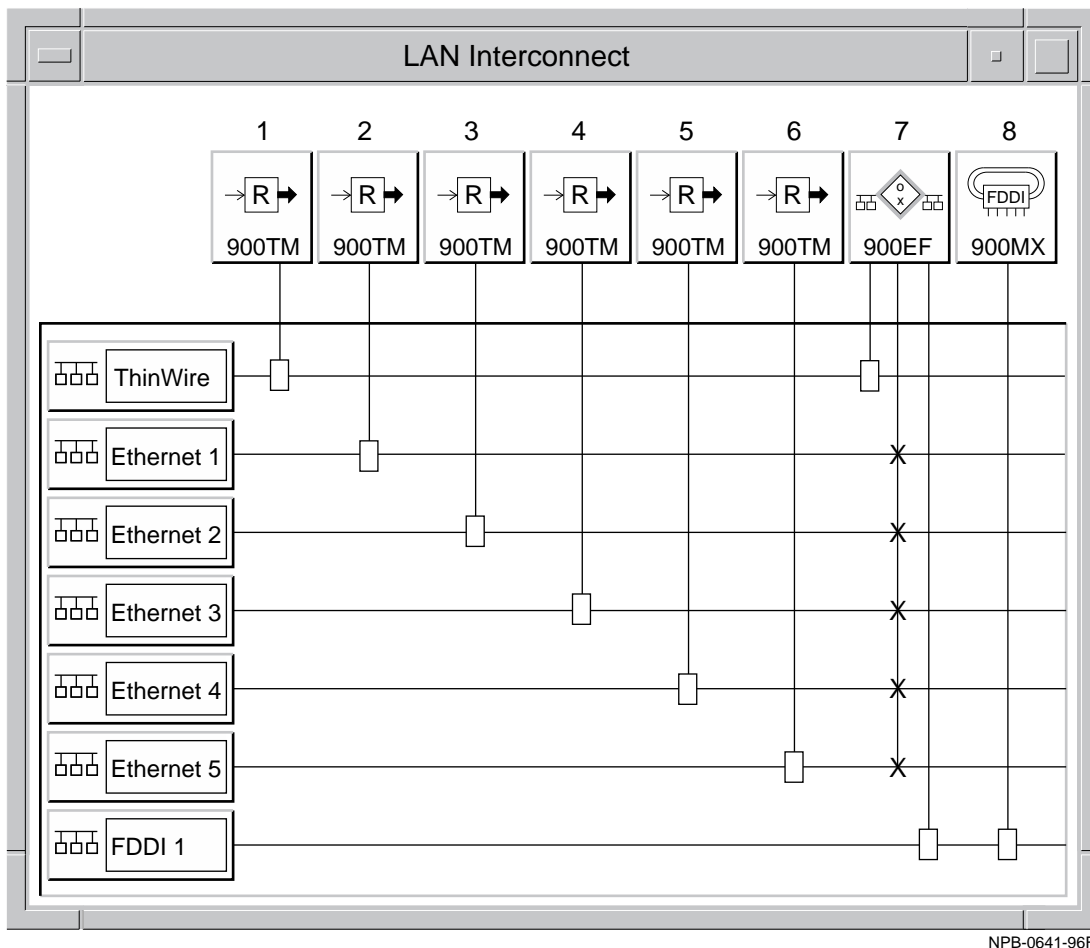

NPB-0641-96F

6.9 Case 8: Remote Access Using Routers and Access Servers

6.9 Case 8: Remote Access Using Routers and Access Servers

Goal

Provide personal computer and terminal users with connectivity flexibility. Typically users will require both local and remote access to the office and remote access to a central corporate site.

Design Requirements

- Support a single multiprotocol Ethernet LAN
- Have network management.

Suggested Configuration

Figure 6–15 shows the sample configuration.

- Platform type: DEChub 90 or Digital MultiStack System.
- Network modules:
 - DECserver 90M
 - RouteAbout EW
 - DECpeater 90C
 - DECpeater 90TS
 - DECpeater 90T16
- High-speed modems to allow network connections to the DECserver.
- DECserver to provide remote node connections.
- RouteAbout to provide the connected users access to corporate databases.
- clearVISN network management software.

6.9 Case 8: Remote Access Using Routers and Access Servers

Figure 6-15 Remote Access Using Routers and Access Servers

DEChub 90

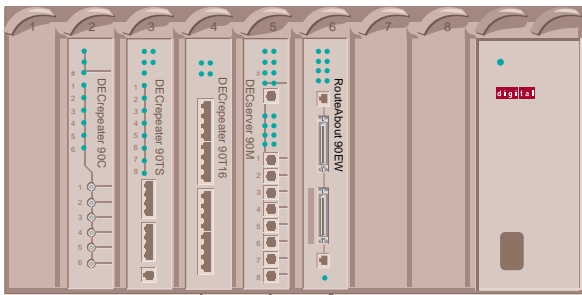

Slot	Module
1	Open
2	DECreeper 90C
3	DECreeper 90TS
4	DECreeper 90T16
5	DECserver 90M
6	RouteAbout EW
7	Open
8	Open

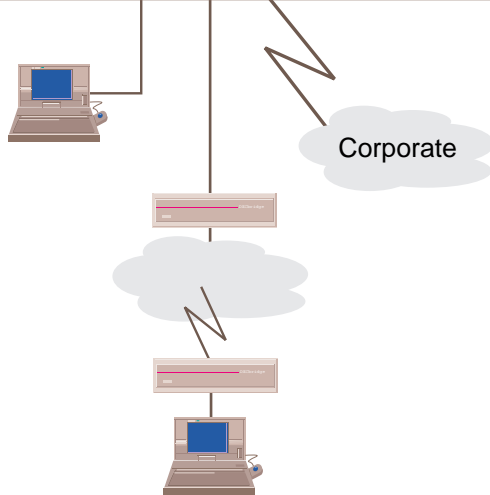

NPB-0379-96F

6.10 Case 9: Connecting Remote Sites to a Cisco Backbone

6.10 Case 9: Connecting Remote Sites to a Cisco Backbone

Goal

Connect remote sites to the existing Cisco backbone.

Design Requirements

- Remote sites need access to existing network with a Cisco backbone.
- Sites use a variety of both routable and non-routable protocols
- Network management.

Suggested Configuration

Figure 6–16 shows the sample configuration.

- DECbrouter routes and/or bridges Ethernet traffic using a broad range of protocols and services.
- DECbrouter supports Ciscos's complete protocol suite.
- DECbrouter can be managed using clearVISN network management software, standard Cisco management tools, or any SNMP management system.
- Network Modules: DECbrouter 90T2

6.10 Case 9: Connecting Remote Sites to a Cisco Backbone

Figure 6–16 Connecting Remote Sites to a Cisco Backbone

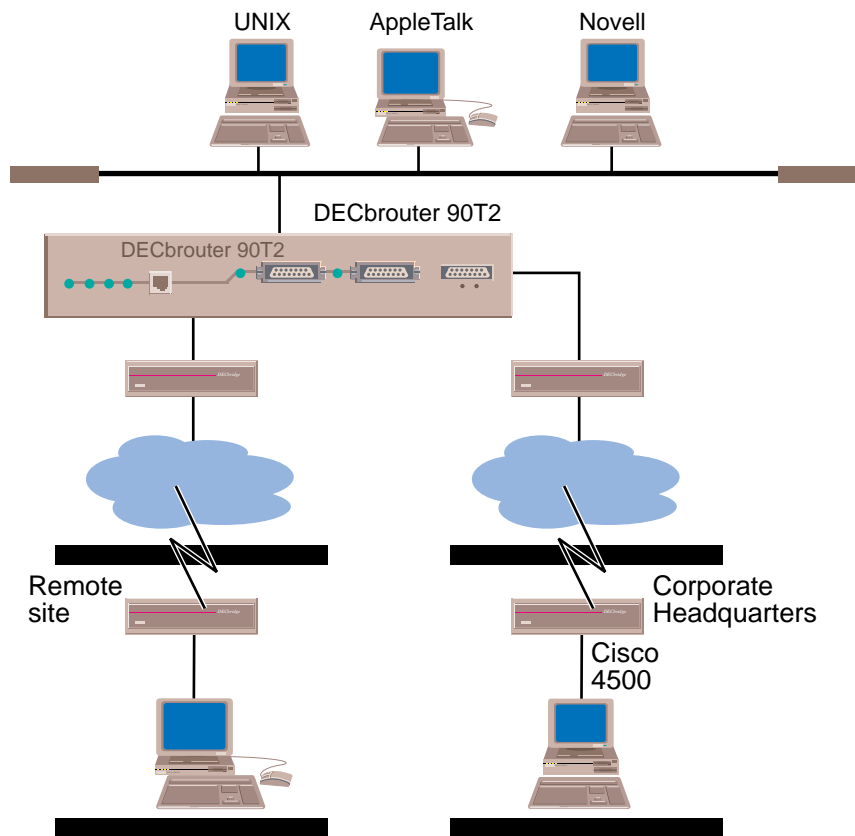

NPB-0423-96F

A

FDDI Configuration Capabilities

This appendix describes FDDI configuration capabilities that are supported in DEChub 900 FDDI network modules. The descriptions discussed in this appendix assume that the reader is familiar with basic FDDI configuration rules and understands the differences between an A, B, M, and S port. If these terms are not familiar to you, refer to Appendix B in this manual for an overview of FDDI concepts that are discussed in this appendix.

A.1 Configuration Guidelines and Rules

A.1 Configuration Guidelines and Rules

This section details the configuration capabilities that are supported in the DEChub 900 family of FDDI products.

A.1.1 Individual FDDI Networks

Individual FDDI networks can be configured as either a dual ring or a tree. This allows compliancy with FDDI configuration rules which operate at the module level and are independent of MultiChassis Manager.

A.1.2 Multiple FDDI Networks

In DEChubs supporting multiple FDDI networks on the backbone, some of the networks can be configured as dual rings and others can be configured as trees, but each of the individual networks can be of only one type. Dual rings of trees can be constructed by interconnecting the various networks across the front panel.

A.1.3 Single Attachment Concentrator (SAC)

Digital's DEChub 900 family of FDDI products include Single Attach Concentrators (SACs) and Dual Attach Concentrators (DACs). A SAC has one S port and can have up to 15 M ports. A DAC has an A and B port, and can have up to 14 M ports.

Implications:

FDDI rules specify that stations with M ports are concentrators. Consequently, when a FDDI switch (such as, a DECswitch 900EF or a PEs switch 900TX) is configured with M and S ports, it reports as a concentrator in FDDI NIF (Neighbor Information Field) and SIF (Signaling Information Field) frame, and in the FDDI and SNMP MIBs.

MultiChassis Manager, FDDI monitors, and FDDI Ring Maps announce the station type of a treed DECswitch 900EF or PEs switch 900TX as a Single Attach Concentrator (SAC), rather than as a Single Attach Station (SAS).

A.1.4 Dual Ring and Trees

The terms, Dual Ring and Tree, are physical descriptions of the network topology. However, in all cases, the FDDI is a logical ring that enables a token to be passed from station-to-station in the ring. The physical implementation can be configured as a tree or a dual ring, but in all cases a logical ring exists.

A.1 Configuration Guidelines and Rules

A.1.5 DEChub 900 Backplane

Technically, any type of configuration (dual ring, tree, or dual ring of trees) can be created in the DEChub 900 backplane; however, for ease of use, only dual ring and tree configurations are supported.

Up to four independent FDDI networks can be created across the DEChub 900 backplane. Each of the created FDDI networks can be either a dual ring or a tree on the backplane, but not a mixture of both.

NOTE

A treed FDDI DEChub 900 backplane can connect to a dual ring that is external to the DEChub 900, and can be part of an overall dual ring of trees configuration.

A.1.6 Point-to-Point Connections

Note that any FDDI connection between two adjacent stations is actually two point-to-point connections, regardless of where the stations are physically located in the configuration (tree or dual ring). This is true for any FDDI product, whether the product is in a hub or operating standalone.

The backplane of the DEChub 900 MultiSwitch is used to make point-to-point connections between DEChub 900 FDDI network modules that are configured in the hub. One backplane channel is needed for each point-to-point connection.

A.1.7 Backplane Channels

Because two point-to-point connections are required between any two ports, two backplane channels are required for each connection between any two ports on the DEChub 900 FDDI network modules, regardless of the actual configuration.

A.2 Dual Ring Configurations

A.2 Dual Ring Configurations

DEChub 900 FDDI network modules support front panel as well as backplane FDDI ports. When configured in a dual ring topology, ports are assigned a ring port (A port or B port) by management.

MultiChassis Manager users can assign a ring port using the Station Configuration window. Any SNMP based management software can also be used.

Because individual FDDI network modules can support a subset of these configurations, each of the FDDI network module capabilities are described in the following sections.

A.2.1 Dual Ring Port Configuration Examples

Figure A-1 shows the basic dual attachment station (DAS) port configurations that can be management assigned.

Figure A-1 Dual Ring Port Configurations

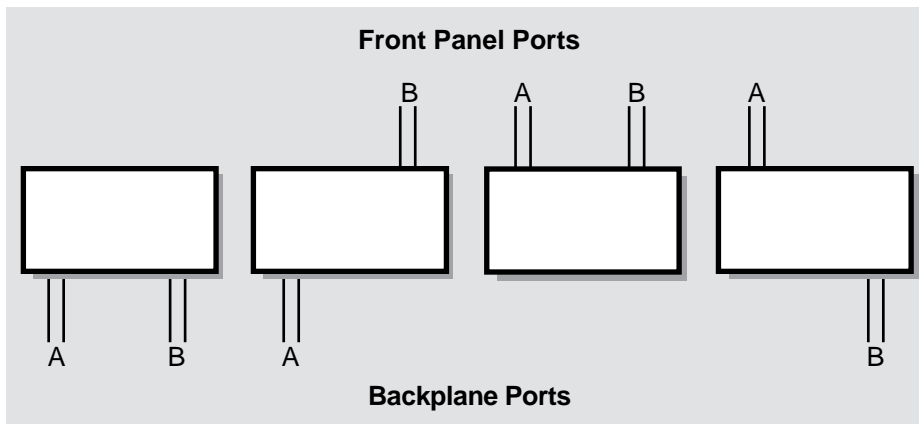

LKG-10063-95F

A.3 Tree Configurations

A.3 Tree Configurations

When connected in a tree configuration, front panel ports and backplane ports are assigned a tree port (M port or S port) by management.

MultiChassis Manager users can assign a tree port using the Station Configuration window. Any SNMP based management software can be used.

A.3.1 Tree Port Configuration Examples

Figure A-2 shows the tree port configurations that can be management assigned.

Figure A-2 Tree Port Configurations

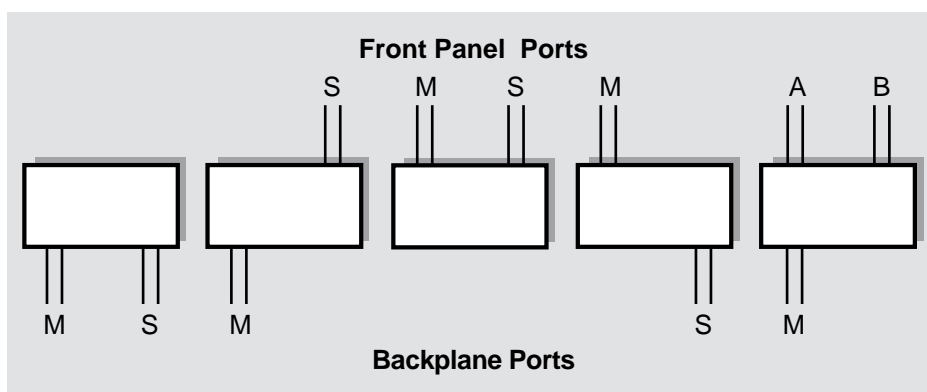

LKG-10064-95F

A.3.2 Dual Homed Configuration

In Figure A-2, note the fifth configuration with an M port in the backplane, and A and B ports on the front panel. This configuration is only implemented in concentrators and is used for connecting to a dual ring, or in a dual homed configuration.

Also, note that when the user accessible FDDI ports are reconfigured as tree ports, the A port always becomes an M port and the B port always becomes an S port. This is true for either front panel ports or ModPMD ports in a DEChub ONE-MX docking station.

A.4 DECconcentrator 900MX

A.4 DECconcentrator 900MX

The DECconcentrator 900MX is an eight-port FDDI concentrator (six front panel ports and two backplane ports). The two backplane ports (see Figure A-3) attach to a DEChub 900 MultiSwitch backplane or to a DEChub ONE-MX docking station that supports ModPMDs.

A.4.1 Port Assignments

Port 1 can be configured as either an A or M port and Port 6 can be configured as either a B, S, or M port. Ports 2 to 5 are always M ports. The two backplane ports (ports 7 and 8) are also software configurable using MultiChassis Manager or the Setup Port menu.

Figure A-3 DECconcentrator 900MX Port Configuration Capabilities

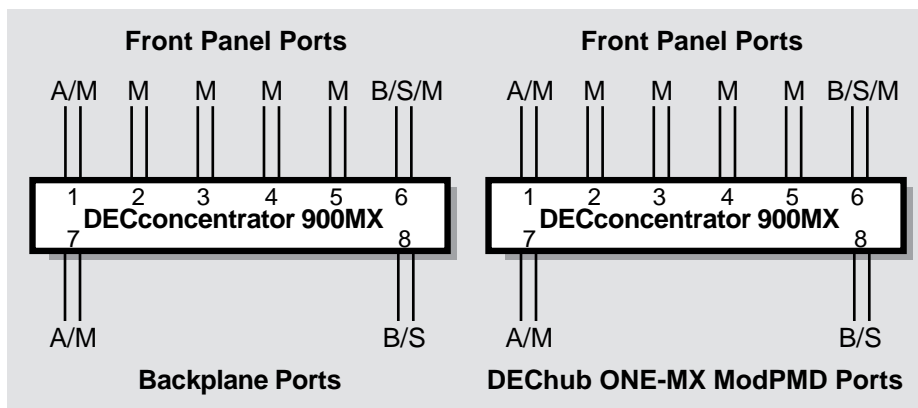

LKG-10066-96F

A.5 DECconcentrator 900TH

A.5 DECconcentrator 900TH

The DECconcentrator 900TH is a sixteen port FDDI concentrator (fourteen front panel ports and two backplane ports). The two backplane ports, see Figure A-4, attach to a DEChub 900 MultiSwitch backplane or to a DEChub ONE-MX docking station that supports ModPMDs.

Twelve of the front panel ports are fixed unshielded twisted pair (UTP) connections. The two remaining ports can be configured for either UTP, multimode fiber (MMF), or single mode fiber (SMF) by the addition of ModPMD modules.

A.5.1 Port Assignments

ModPMD Port 1 can be configured as either an A or M port and ModPMD Port 2 can be configured as either a B, S, or M port. The two backplane ports are also software configurable through MultiChassis Manager or the Setup Port menu. Therefore, both dual ring and tree connections can be supported.

Figure A-4 DECconcentrator 900TH Port Configuration Capabilities

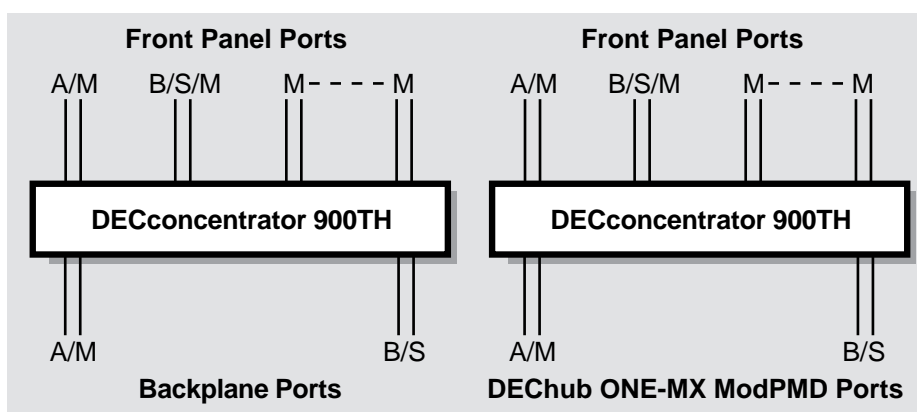

LKG-10067-96F

A.6 DECconcentrator 900FH

A.6 DECconcentrator 900FH

The DECconcentrator 900FH is a sixteen port FDDI concentrator (fourteen front panel ports and two backplane ports). The two backplane ports, see Figure A-5, attach to a DEChub 900 MultiSwitch backplane or to a DEChub ONE-MX docking station that supports ModPMDs.

Twelve of the front panel ports are fixed multimode fiber (MMF), SC optics connections. The two remaining ports can be configured for either UTP, multimode fiber (MMF), or single mode fiber (SMF) by the addition of ModPMD modules.

A.6.1 Port Assignments

ModPMD Port 1 can be configured as either an A or M port and ModPMD Port 2 can be configured as either a B, S, or M port. The two backplane ports are also software configurable through MultiChassis Manager or the Setup Port menu. Therefore, both dual ring and tree connections can be supported.

Figure A-5 DECconcentrator 900FH Port Configuration Capabilities

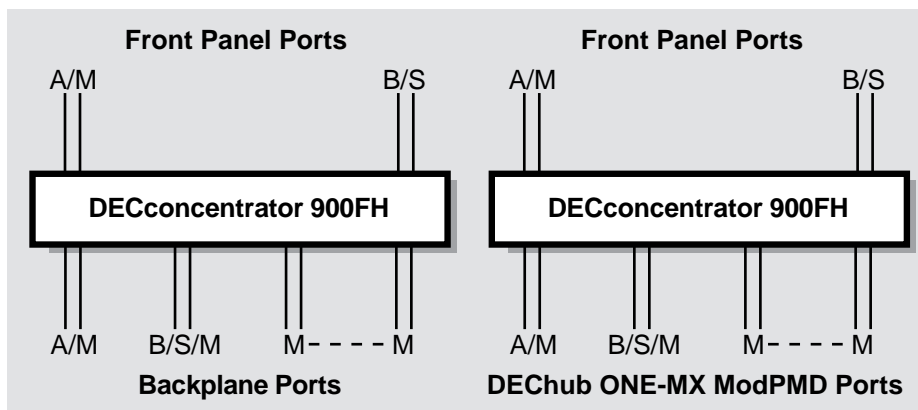

LKG-10124-96F

A.7 DECswitch 900EF

A.7 DECswitch 900EF

The DECswitch 900EF (previously called the DECbridge 900MX) supports two FDDI ports that can be individually assigned to either the module's front panel (Port 1A/M and Port 1B/S) or to the backplane ports for connection to a DEChub 900 MultiSwitch or to a DEChub ONE-MX docking station. Therefore, the DECswitch 900EF module can have only two FDDI ports that are active at any time (for example, two front panel ports, one front panel and one backplane port, or two backplane ports).

A.7.1 Port Assignments

The FDDI port assignments are software configurable via MultiChassis Manager or the setup port menu. Figure A-6 shows how two front panel ports, two backplane ports, or a front panel port and a backplane port can be configured as A and B ports or M and S ports.

Figure A-6 DECswitch 900EF Port Configuration Capabilities

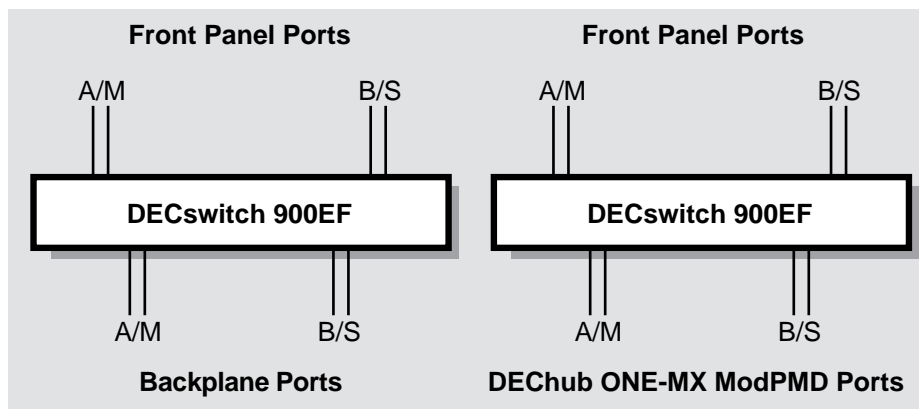

LKG-10068-96F

A.8 PEswitch 900TX

A.8 PEswitch 900TX

Unlike the DECswitch 900EF module, the PEswitch 900TX module supports two FDDI port connections to the DEChub 900 MultiSwitch backplane or to the DEChub ONE-MX docking station only. There are no front panel FDDI ports on the PEswitch 900TX module.

A.8.1 Port Assignments

The FDDI port assignments are software configurable via MultiChassis Manager or the set up port menu. Figure A-7 shows how the backplane FDDI ports can be configured as either A and B or M and S connections at any time.

Figure A-7 PEswitch 900TX Port Configuration Capabilities

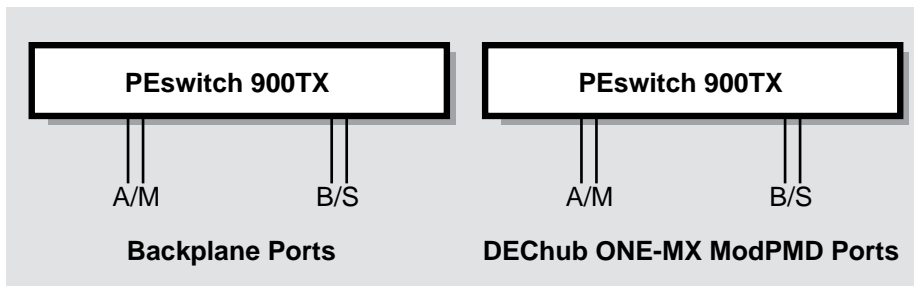

LKG-10069-96F

A.9 FDDI in the Hub Backplane

A.9 FDDI in the Hub Backplane

The DEChub 900 MultiSwitch and the DEChub ONE-MX use a building block approach for configuring FDDI on the backplane. The network manager assigns a port type by selecting a building block.

A.9.1 FDDI Building Blocks

Building blocks are divided into two groups:

- Ring Building Blocks
- Tree Building Blocks

There are nine building blocks; four are used for building dual rings, and five are used for building trees.

MultiChassis Manager only allows connections to be made between building blocks of the same group (ring group or tree group), in order to avoid errors such as connections that break because of the FDDI standard's preference for trees over dual rings.

A.9.2 Ring Building Blocks

The four ring building blocks, see Figure A–8, are as follows:

Name	Description
Trunk B	Port A connects to the FDDI network module front panel ports. Port B connects to the DEChub 900 backplane or to the DEChub ONE-MX ModPMD.
Trunk AB	Ports A and B connect to the DEChub 900 backplane or to the DEChub ONE-MX ModPMD.
Trunk A	Port A connects to the DEChub 900 backplane or to the DEChub ONE-MX ModPMD. Port B connects to the FDDI network module front panel port.
Stump Primary	Ports A and B connect to the FDDI network module's front panel port.

A.9 FDDI in the Hub Backplane

Figure A–8 Ring Building Blocks

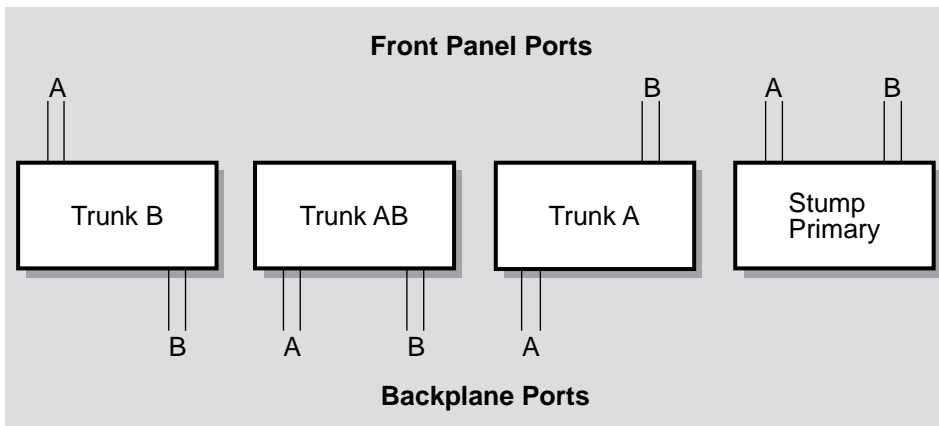

LKG-10070-96F

A.9.3 Tree Building Blocks

The five tree building blocks, see Figure A–9, are as follows:

Name	Description
Nonroot MS	Ports M and S connect to the DEChub 900 backplane or to the DEChub ONE-MX ModPMDs.
Nonroot M	Port M connects to the DEChub 900 backplane or to the DEChub ONE-MX ModPMD. Port S connects to the FDDI network module front panel port.
Nonroot SAC	Ports M and S connect to the FDDI network module front panel ports.
Nonroot S	Port S connects to the DEChub 900 backplane or to the DEChub ONE-MX ModPMD. Port M connects to the FDDI network module front panel port.
Root Primary	Ports A and B connect to the FDDI network module front panel ports. Port M connects to the DEChub 900 backplane or to the DEChub ONE-MX ModPMD.

A.9 FDDI in the Hub Backplane

Figure A-9 Tree Building Blocks

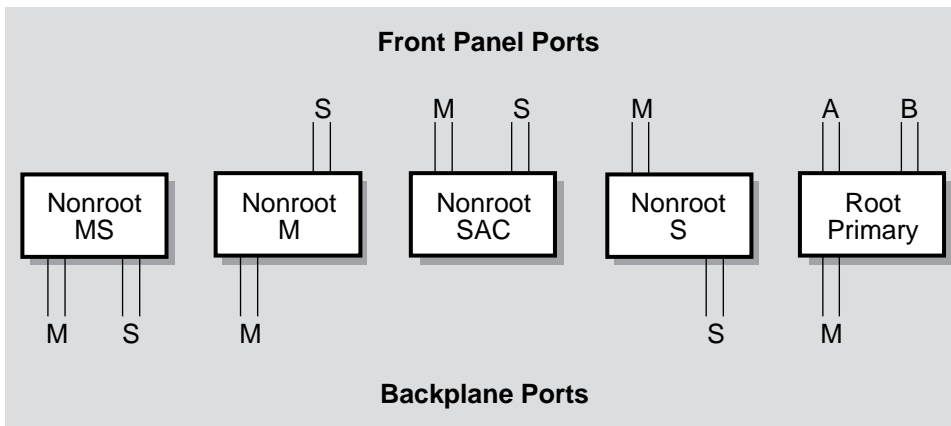

LKG-10071-96F

A.10 Default Configurations

A.10 Default Configurations

This section describes the default (or factory set) configurations that apply to the FDDI network modules. Note that the default settings vary according to module type, and whether the module is installed into a DEChub 900 MultiSwitch, DEChub ONE or DEChub ONE-MX docking station.

A.10.1 FDDI Network Modules in a DEChub 900

When FDDI network modules (DECconcentrator 900MX, DECconcentrator 900FH, DECconcentrator 900TH, and DECswitch 900EF) are installed into a DEChub 900 MultiSwitch, the default configuration is as follows:

- All front panel ports are active.
- The A and B ports connect to the module's front panel ports.

This means that no redirection to backplane ports or backplane connections is made between FDDI network modules unless the network manager chooses to do so.

The network manager can issue the appropriate MultiChassis Manager commands to establish FDDI networks across the backplane of the DEChub 900 MultiSwitch.

While the default for the PEs witch 900TX is to the backplane ports, no FDDI LAN connections across the DEChub 900 backplane are made by default. The network manager must issue the appropriate MultiChassis Manager commands to connect a PEs witch 900TX to a FDDI backplane LAN.

A.10.2 FDDI Network Modules in a DEChub ONE or DEChub ONE-MX

When FDDI network modules (DECconcentrator 900MX, DECconcentrator 900FH, DECconcentrator 900TH, and DECswitch 900EF) are installed into a DEChub ONE or into a DEChub ONE-MX, the default configuration is as follows:

- All front panel ports are active.
- The A and B ports connect to the module's front panel ports.

PEs witch 900TX:

The default configuration for the PEs witch 900TX is as follows:

- The A port and B port connect to the DEChub ONE-MX ModPMD ports.

No FDDI connections are available when the PEs witch 900TX is installed to a DEChub ONE (see Note).

A.10 Default Configurations

NOTE

The DEChub ONE (DEHUA) supports one Ethernet connection, and the DEChub ONE-MX (DEF1H) supports one Ethernet connection and up to two ModPMD FDDI connections.

A.10.3 Enabling ModPMD Ports

To use the ModPMD ports of the DEChub ONE-MX a network manager must issue the appropriate MultiChassis Manager commands to enable the ModPMD ports, using the building blocks previously described. This task can be accomplished using MultiChassis Manager or through the setup port of the DEChub ONE-MX docking station.

A.10.4 Power Failure Recovery

Modules in a DEChub ONE or DEChub ONE-MX retain their configuration so that, in the event of a power failure, the module returns to the previously configured state. This previous configuration recall ability applies if a module is removed (powered off) and then moved to another DEChub ONE docking station that is of the same model type.

A.10.5 Change of Environment

FDDI network modules recognize a change of environment when moved between a DEChub 900 MultiSwitch, or a DEChub ONE-MX, or a DEChub ONE docking station.

When a change of environment is detected, with the exception of the PEs switch 900TX, the FDDI network modules assume the following default configuration: A port and B port connect to the network module's front panel.

The PEs switch 900TX module assumes the following default configuration: A port and B port connect to the module's backplane ports only (and not to any DEChub 900 backplane FDDI LAN) or to the DEChub ONE-MX ModPMD ports.

A.10 Default Configurations

A.10.6 Example of Module Reacting to Change of Environment

If a DECswitch 900EF module, that is configured with an S port and M port on the ModPMDs, is moved from a DEChub ONE-MX docking station to another, the module powers up with the ModPMDs of the second DEChub ONE-MX enabled as S and M ports (previous configuration recall ability).

If the same module is then moved (from the DEChub ONE-MX docking station) to a DEChub ONE docking station, the module detects an environment change, and powers up with the front panel ports enabled as A and B ports (the module's default configuration).

If the module is again moved back to a DEChub ONE-MX docking station (from the DEChub ONE docking station), the module again detects a new environment, and powers up with the front panel ports enabled as A and B ports (default configuration).

Also, if a module is moved from a DEChub ONE-MX to another that has a different ModPMD configuration, the module powers up and, sensing that it is still in a DEChub ONE-MX, configures the ports per the previous configuration recall process. The FDDI Network configuration recall process does not detect a change in the media type of the ModPMDs in the DEChub ONE-MX.

A.11 FDDI Tree Configuration Examples

A.11 FDDI Tree Configuration Examples

The DEChub 900 backplane supports many types of FDDI tree configurations. FDDI trees can be contained within the hub backplane and can connect an individual tree in the hub backplane to a higher level of a tree, or can be used to interconnect other hubs.

This section provides five examples of FDDI tree configurations that are supported in the DEChub 900 backplane:

- Example 1 — Self-contained Tree of Concentrators in Hub Backplane
- Example 2 — Self-contained Tree of Switches and Concentrators in Hub Backplane
- Example 3 — Tree Connections to an External Concentrator
- Example 4 — Dual Homing and Connection to an External Ring
- Example 5 — FDDI Tree Extensions

A.11.1 Example 1 — Self-contained Tree of Concentrators in Hub Backplane

In this example (see Figure A-10), an FDDI tree is constructed entirely within the Hub backplane. The backplane ports of the concentrator modules are enabled as M ports and S ports. The front panel ports become M ports.

The module that is installed in the highest slot number of the Hub (Concentrator 3) is designated as the *top of the tree*, and its M port connects to the S port of the module with the second highest slot number (Concentrator 2).

Two Hub backplane channels are required for each connection. In Figure A-10, a total of four backplane channels are in use.

A.11 FDDI Tree Configuration Examples

Figure A-10 DECconcentrator Tree Connections in Hub Backplane

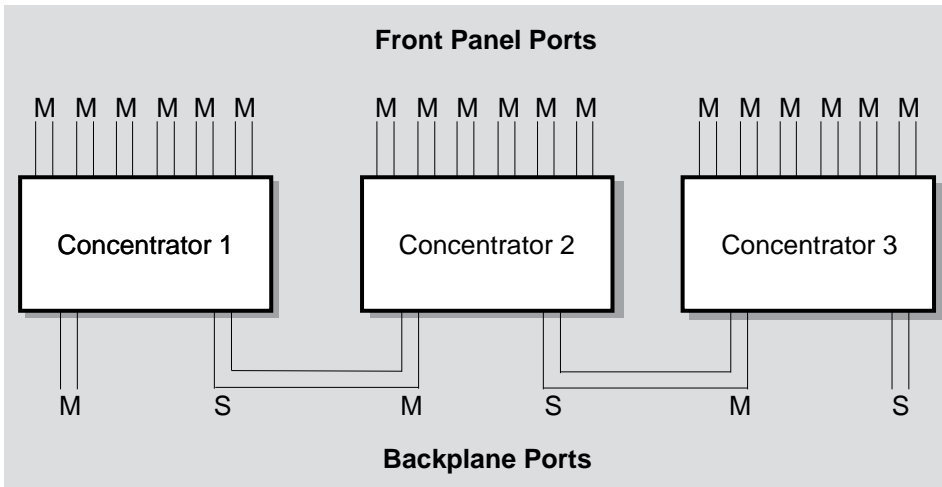

LKG-10074-96F

Figure A-11 shows the building block representation of the configuration example described in Figure A-10.

Figure A-11 Building Block Representation of Example 1

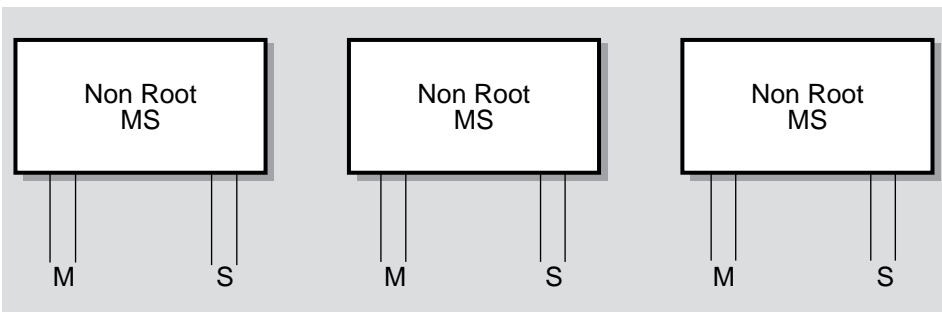

LKG-10075-96F

A.11 FDDI Tree Configuration Examples

A.11.2 Example 2 — Self-contained Tree of Switches and Concentrators in Hub Backplane

In this example (see Figure A-12), an FDDI tree is constructed entirely within the hub backplane; however, a mixture of FDDI network module types (switches and concentrators) is used. The backplane ports of the FDDI network modules are enabled as M ports and S ports. The front panel ports of the concentrators become M ports, and the front panel FDDI ports of the switches become unusable.

The module that is installed in the highest slot number of the hub (DECswitch 900EF) is designated as the *top of the tree*, and its M port connects to the S port of the module with the second highest slot number (PEswitch 900TX).

Two hub backplane channels are required for each connection. In Figure A-12, a total of four backplane channels are in use.

Figure A-12 Tree Connections with Switches and Concentrators

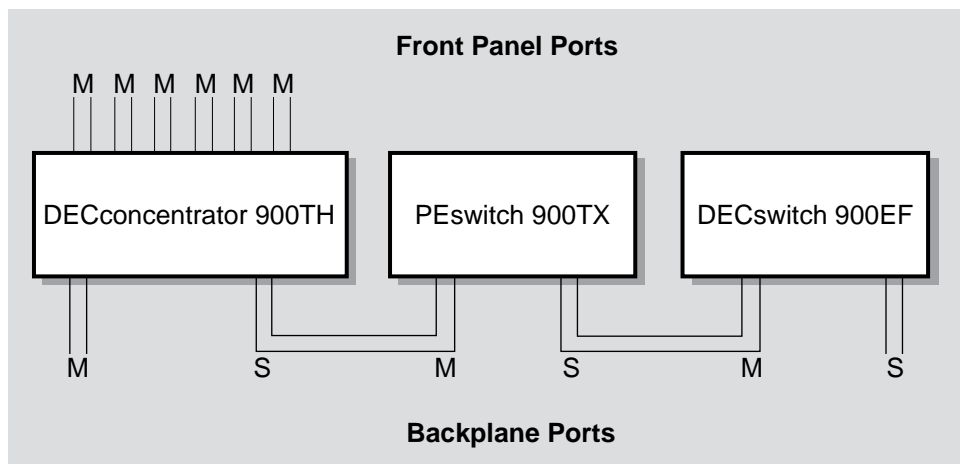
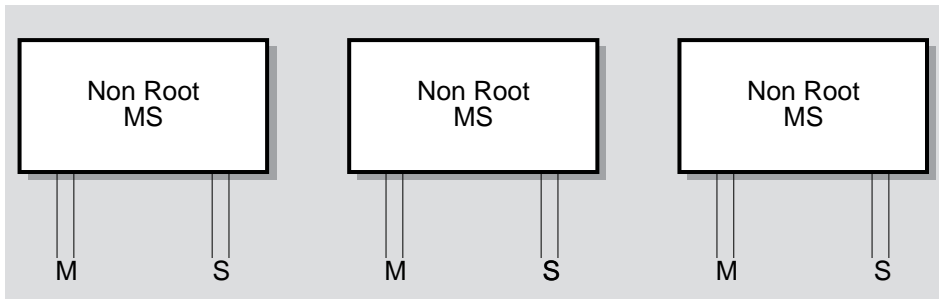

Figure A-13 shows the building block representation of the configuration example described in Figure A-12.

A.11 FDDI Tree Configuration Examples

Figure A-13 Building Block Representation of Example 2



LKG-10077-96F

A.11.3 Example 3 — Tree Connections to an External Concentrator

FDDI trees that are constructed within the hub backplane can connect to an external higher level concentrator by configuring one of the FDDI network modules with a front panel S port, and configuring all other FDDI network modules with backplane M and S ports.

As shown in Figure A-14, a tree of PEs switch 900TX modules can be connected to an external FDDI ring using either a DEC switch 900EF network module (or a concentrator) to make the external connection.

A.11 FDDI Tree Configuration Examples

Figure A-14 Tree Connections to an External FDDI Network

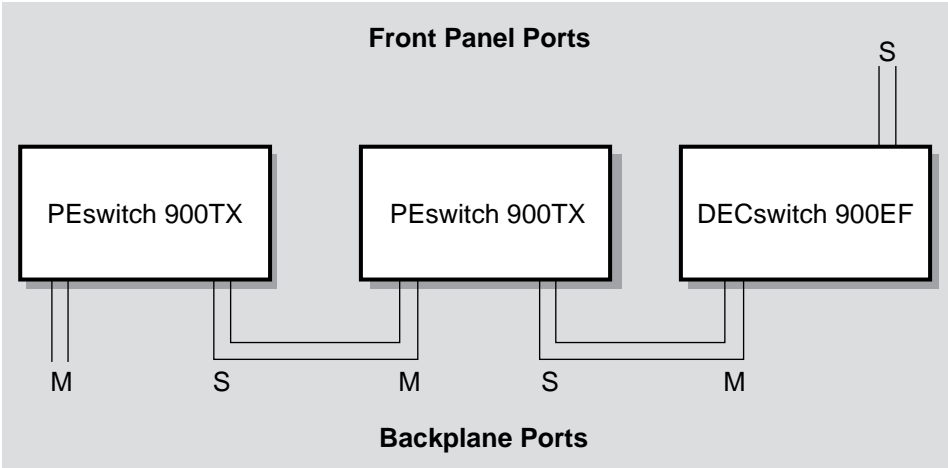

LKG-10078-96F

Figure A-15 shows the building block representation of the configuration example described in Figure A-14.

Figure A-15 Building Block Representation of Example 3

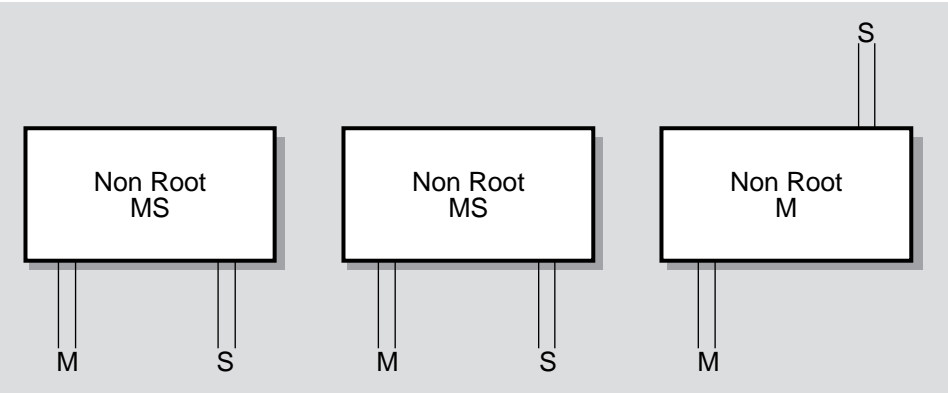

LKG-10079-96F

A.11 FDDI Tree Configuration Examples

A.11.4 Example 4 — Dual Homing and Connection to an External Dual Ring

In some cases it is desirable to connect the hub to an external dual ring, and configure the network modules as FDDI trees within the hub backplane. In other cases, it is also desirable to have a redundant connection from the hub to higher level concentrators.

This second case (see Figure A-16) is commonly referred to as dual homing. Either of these configurations requires the use of a concentrator at the top level of the FDDI tree configuration.

NOTE

The network modules that are connected through the hub backplane are single attachment station (SAS) modules. The term *dual homing*, in this case, refers to the connection between the hub based tree and the external concentrators.

Figure A-16 External Dual Homed Connections to an FDDI Network

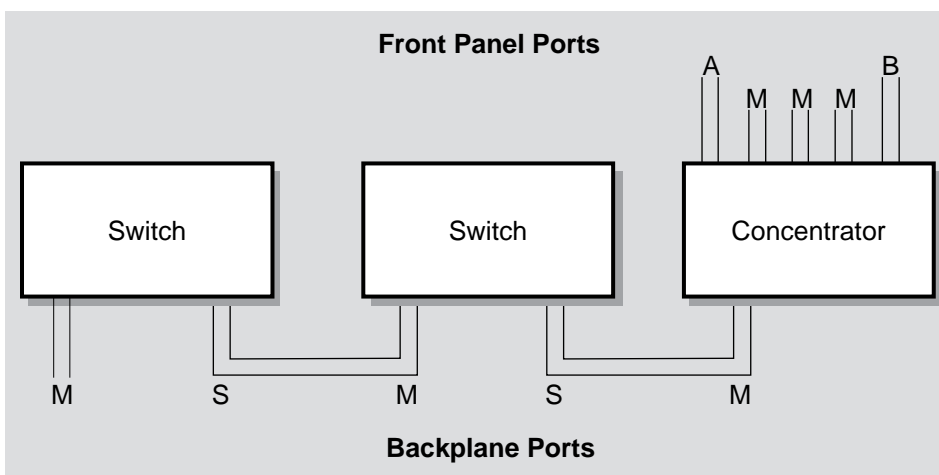
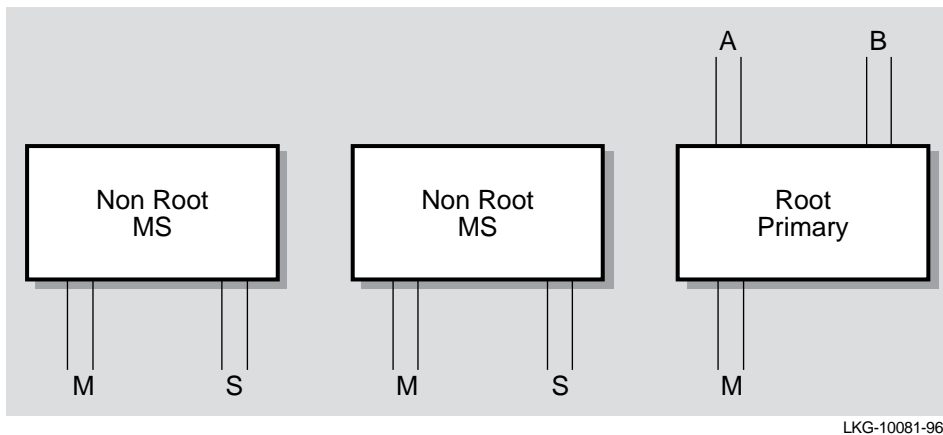

Figure A-17 shows the building block representation of the configuration example described in Figure A-16.

A.11 FDDI Tree Configuration Examples

Figure A-17 Building Block Representation of Example 4



A.11.5 Example 5 — FDDI Tree Extensions

You can configure an FDDI network module, that is at the end of a branch of an FDDI tree, with front panel M ports. The M port can then be used to connect to an external FDDI network module or to an additional hub (see Figure A-18).

This configuration is used in situations where it is necessary to configure multiple hubs or hub network modules into trees (for example, when more than eight modules are required in the same closet).

A.11 FDDI Tree Configuration Examples

Figure A-18 Hub-Based Tree Connections to an External FDDI Network

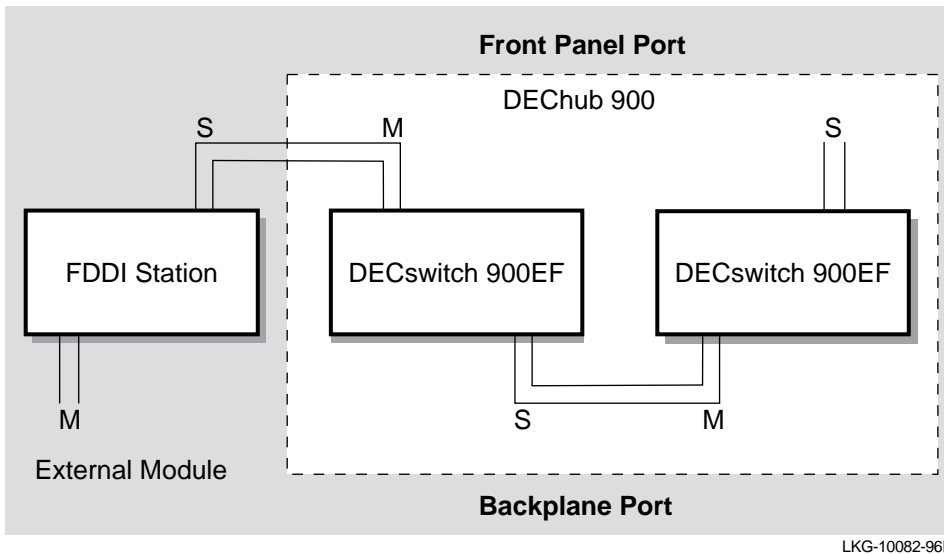
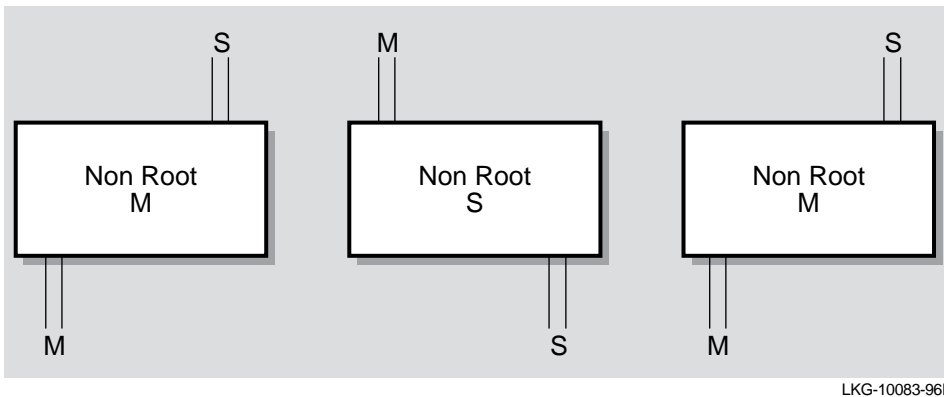

Figure A-19 shows the building block representation of the configuration example described in Figure A-18.

Figure A-19 Building Block Representation of Example 5



A.12 Dual Ring Configuration Examples

A.12 Dual Ring Configuration Examples

Both dual rings and trees are supported across the DEChub 900 MultiSwitch backplane. However, because it has more robust and quicker fault tolerance capabilities than tree configurations, the dual ring configuration is more effective to use across the backplane.

This section provides four examples of FDDI dual ring configurations that are supported in the DEChub 900 backplane:

- Example 1 — Dual Ring Concentrators Connected to an External Dual Ring
- Example 2 — Dual Ring Switches Connected to an External Dual Ring
- Example 3 — PEs switch 900TX Connections to an External Dual Ring
- Example 4 — Self Contained Dual Ring in the Backplane

A.12.1 Example 1 — Dual Ring Concentrators Connected to an External Dual Ring

As shown in Figure A–20, all of the concentrators connect directly to the dual ring for this dual ring configuration.

Concentrator 3 has one of its front panel ports configured as the external B port connection to the dual ring and one of its backplane ports configured as the A port.

Concentrator 2 uses both backplane ports as the A port and B port connections to the dual ring.

Concentrator 1 uses the backplane B port connection to the dual ring allowing the dual ring to exit through a front panel A port.

A.12 Dual Ring Configuration Examples

Figure A-20 DECconcentrator Dual Ring Connected to an FDDI Network

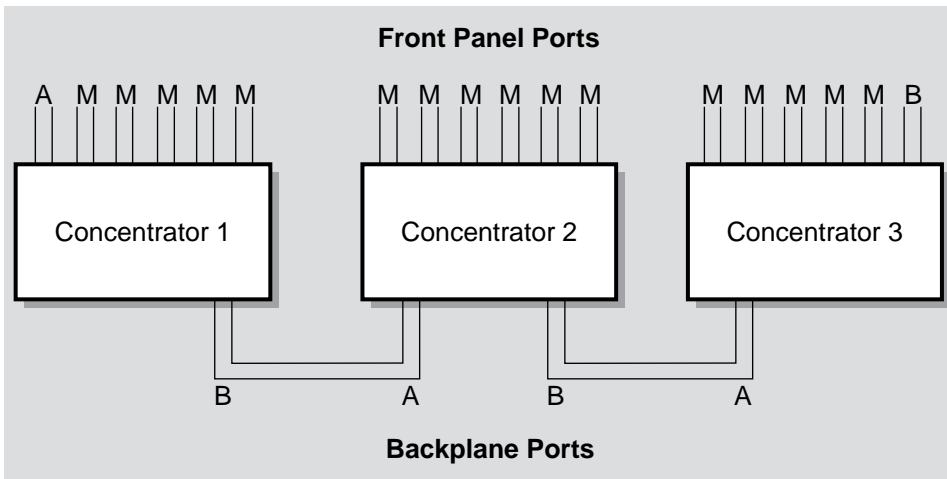

LKG-10084-96F

Figure A-21 shows the building block representation of the configuration example described in Figure A-20.

Figure A-21 Building Block Representation of Example 1

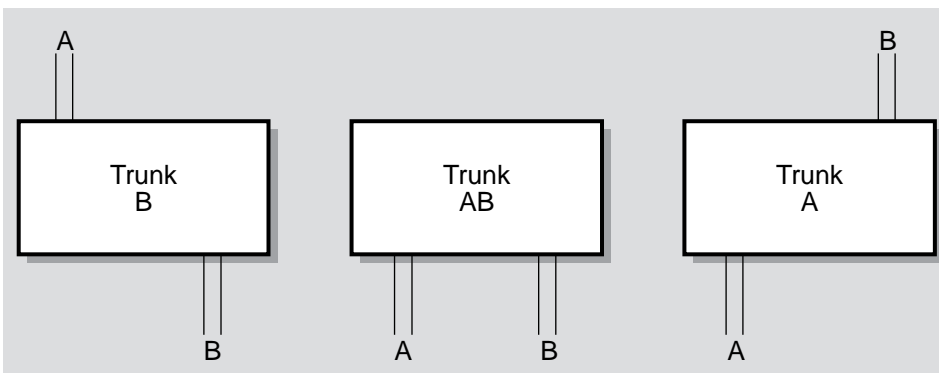

LKG-10085-96F

A.12 Dual Ring Configuration Examples

A.12.2 Example 2 — Dual Ring Switches Connected to an External Dual Ring

As shown in Figure A–22, all of the DECswitch 900EF modules (Switches 1 through 3) can connect directly to the dual ring for this dual ring configuration (similar to the concentrators shown in Example 1).

Switch 3 has its B port assigned to the front panel port connection and the A port assigned to the backplane port connection.

Switch 2 has its A and B ports assigned to the backplane ports only (the module's front panel ports are not active, nor usable).

Switch 1 has its B port assigned to a backplane port and its A port is assigned to the front panel port.

You can also assign both A and B ports to the front panel ports (the Stump Primary building block, see Figure A–8), which allows a single DECswitch 900EF or DEC-concentrator in a DEChub 900 to connect to an external FDDI backbone network.

Figure A–22 Dual Ring Connections for DECswitch 900EF

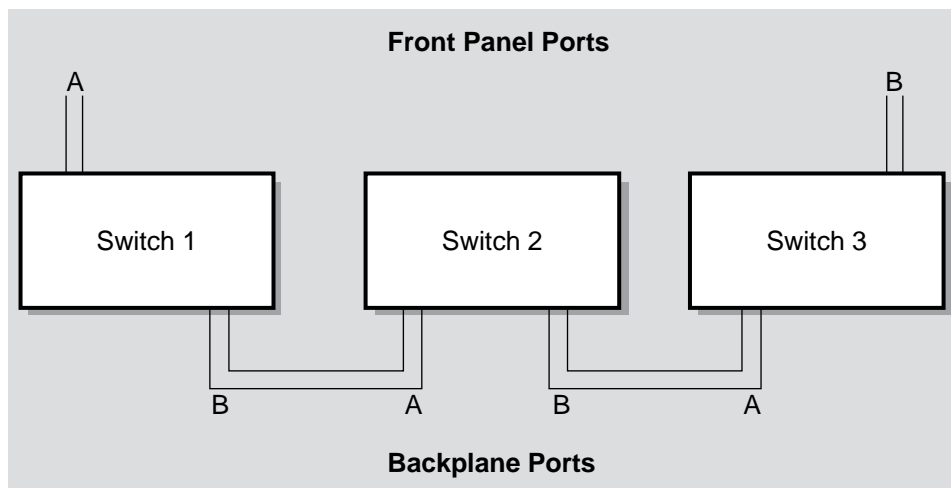

LKG-10086-96F

Figure A–23 shows the Building block representation of the configuration example described in Figure A–22.

A.12 Dual Ring Configuration Examples

Figure A-23 Building Block Representation of Example 2

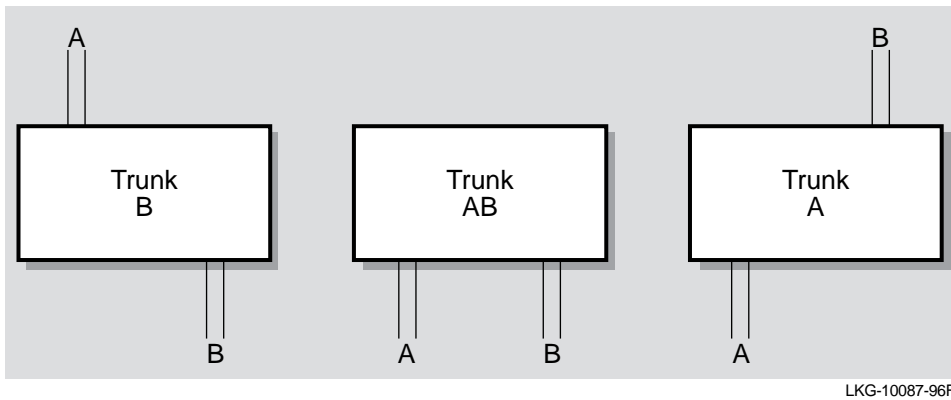

A.12.3 Example 3 — PEs witch 900TX Connections to External Dual Ring

The PEs witch 900TX module can be configured into a dual ring, however, because the module does not have front panel FDDI port connectors, two DECswitch 900EF modules or two DECconcentrator modules (in any combination) are required to complete the connection to an external FDDI network.

As shown in Figure A-24, the FDDI dual ring connections to a PEs witch 900TX are made by means of the DEChub 900 backplane: (1) the dual ring enters through the DECconcentrator 900TH; (2) it then passes through the DEChub 900 backplane to a PEs witch 900TX; (3) from the PEs witch 900TX it again passes through the DEChub 900 backplane to exit through a DECswitch 900EF

A.12 Dual Ring Configuration Examples

Figure A-24 Dual Ring Connections for PEs witch 900TX

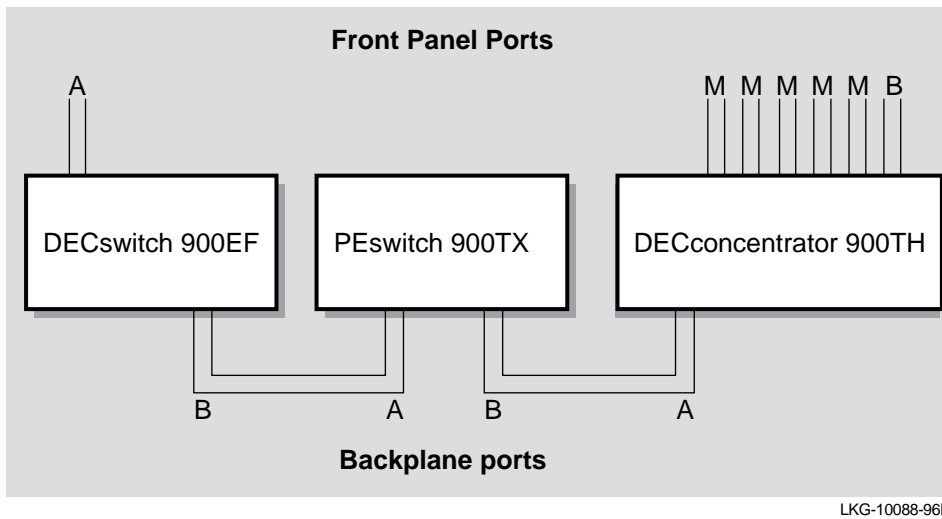
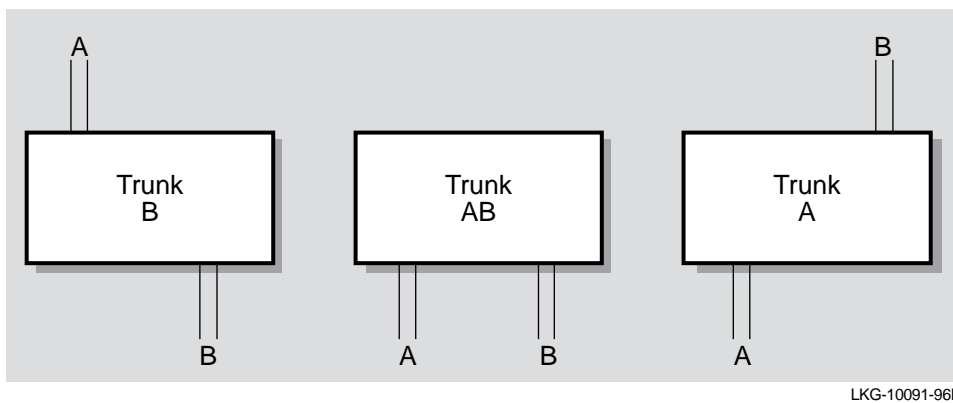

Figure A-25 shows the Building block representation of the configuration example described in Figure A-24.

Figure A-25 Building Block Representation of Example 3



A.12 Dual Ring Configuration Examples

A.12.4 Example 4 — Self Contained Dual Ring in the Backplane

You can create a dual ring, that is completely contained in the DEChub 900 backplane, by connecting all the backplane ports of the FDDI network modules together (see Figure A-26).

Note that the DECconcentrator in Figure A-26 is providing M port tree connections to externally treed FDDI stations (such as, bridges, concentrators or end user stations that use S, A, or B ports). The Concentrator is not connected to an external M port such as an external concentrator's M port.

Figure A-26 Self-Contained Dual Ring in the Backplane

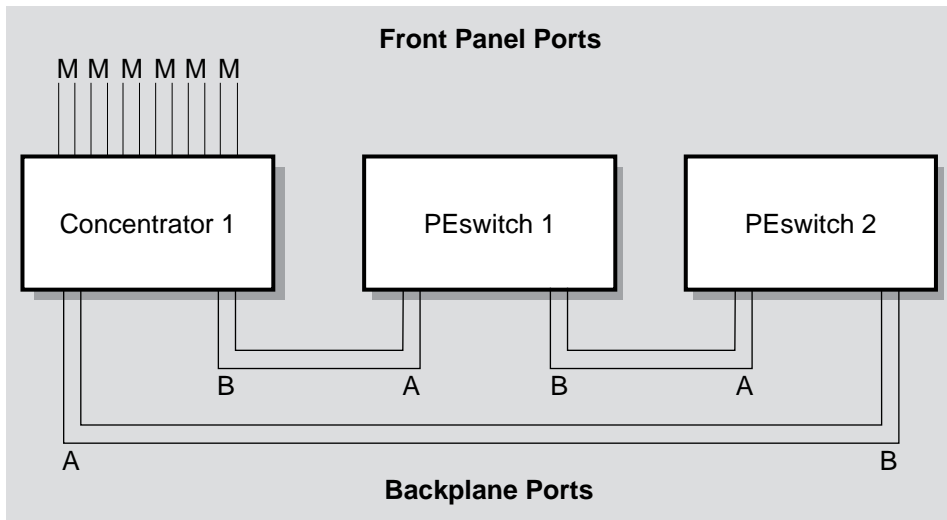

LKG-10092-96F

A.13 Fault Tolerance in Dual Rings

A.13 Fault Tolerance in Dual Rings

This section describes the fault tolerant safeguards that are built into DEChub 900 network modules.

A.13.1 Maintaining Network Connectivity

When a concentrator or switch in a dual ring is removed (hot swapped), the FDDI ring wraps according to FDDI standards. If the removed module has both A and B ports that are connected to the DEChub 900 backplane, the Hub Manager detects the removal and reconnects the two neighboring (upstream and downstream) FDDI stations.

If a network module is detected as being unavailable, the Hub Manager will also patch-out the module (as long as Auto Healing has been enabled).

This is a distinct advantage that FDDI modules, which are configured into a dual ring in a DEChub, have over individual nonhub-based FDDI network modules.

NOTE

Because ring wrap occurs much faster than backplane healing, it always occurs first. Thereafter, the Hub Manager firmware automatically reconnects the disconnected DAS stations through the DEChub 900 backplane, allowing the dual ring to unwrap. Fault recovery (unwrapping of the dual ring in the DEChub 900 backplane) is supported in all DEChub 900 FDDI network modules.

A.13.2 Example of Dual Ring Backplane Healing

As shown in Figure A-27, if Concentrator 1 is removed, Concentrator 2 and Switch 1 continue communications with each other and with all other FDDI stations on the DAS backbone. This is so, because Concentrator 2 (sensing the change) wraps the FDDI dual ring.

If Concentrator 2 fails, Concentrator 1 and Switch 1 wrap the dual ring and communications can continue. Within seconds of this particular ring wrap, where Concentrator 2 has become unavailable, the Hub Manager automatically reconnects Switch 1 to Concentrator 1 and the dual ring unwraps.

A.13 Fault Tolerance in Dual Rings

If, at a later time, a replacement concentrator of the same type is installed into the same slot that held Concentrator 2, the replacement concentrator will be reinserted into the ring through the Auto Healing feature.

Figure A-27 Ring Configuration

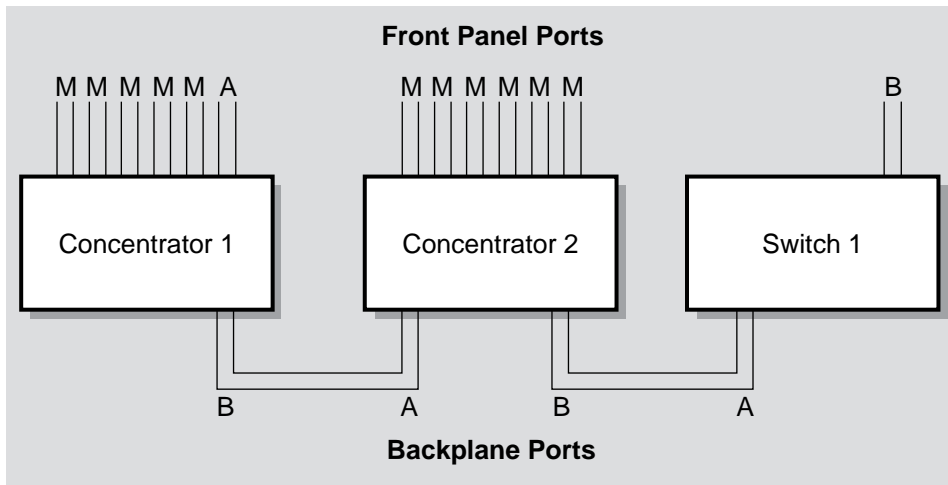

LKG-10093-96F

A.14 Fault Tolerance in Trees

A.14 Fault Tolerance in Trees

This section describes the fault tolerant safeguards (for trees) that are built into DEChub 900 network modules.

A.14.1 Maintaining Network Connectivity

When a concentrator or switch in a tree is removed (hot swapped), the FDDI tree splits into two independent networks, per the FDDI standard.

If the removed module has both M and S ports that are connected to the DEChub 900 backplane, the Hub Manager detects the removal and reconnects the two neighboring (upstream and downstream) FDDI stations.

If a network module is detected as being unavailable, the Hub Manager will also patch-out the module (as long as Auto Healing has been enabled). This is a distinct advantage that FDDI modules, which are configured into a tree in a DEChub, have over individual nonhub-based FDDI network modules.

NOTE

If the auto-healing function is enabled, MultiChassis Manager prevents the user from adding or deleting FDDI connections, Ethernet connections, Ethernet LANs or FDDI LANs via the LAN Interconnect screen. This is designed to preserve the existing configuration until someone can physically replace any failed modules. An error message is displayed informing the user that the requested action cannot be taken, and offers a list of alternatives. If the change is still desired, the user must first disable Auto Healing by selecting "Disable" from the Auto Healing buttons on the LAN Interconnect screen. This deletes the patched-out connections. Following the reconfiguration, Auto Healing can be re-enabled. This new configuration is shown on the screen.

A.14 Fault Tolerance in Trees

A.14.2 Example of Tree Backplane Healing

As shown in Figure A–28, if Concentrator 1 is removed, Concentrator 2 and Switch 1 continue communications with each other and with all other FDDI stations in the tree.

If Concentrator 2 fails, Concentrator 1 and Switch 1 can no longer communicate with each other. Within seconds of when Concentrator 2 becomes *unavailable*, the Hub Manager automatically reconnects Switch 1 to Concentrator 1 and the tree is reestablished.

If, at a later time, a replacement concentrator of the same type is installed into the same slot that held Concentrator 2, the replacement concentrator is reinserted into the tree through the Auto Healing feature.

Figure A–28 Tree Configuration

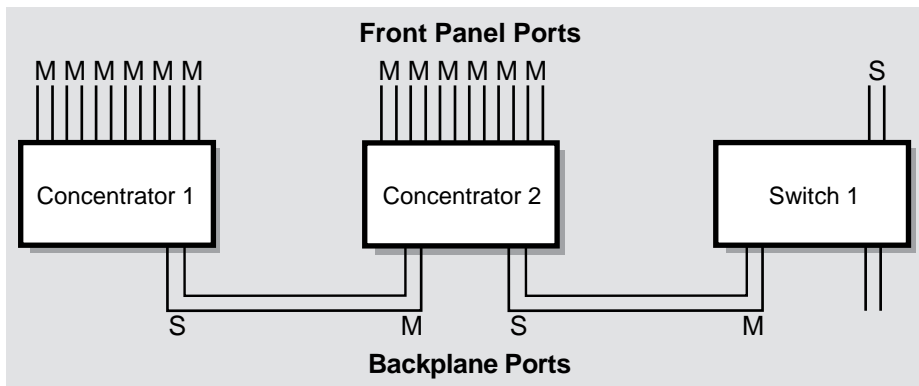

LKG-10125-96F

A.15 Token Ordering of Trees or Dual Rings

A.15 Token Ordering of Trees or Dual Rings

The DEChub 900 backplane uses a defined token order algorithm for FDDI dual rings or trees that are created in the hub. This section describes how the algorithm controls the token flow in the DEChub 900 backplane.

A.15.1 Description

The token flow is defined as the order in which the token flows to the MAC addressed slots in the DEChub 900 backplane. The token flow is from slot 1 towards slot 8, whether the backplane network is a dual ring or a tree. If there are multiple FDDI networks, each of the networks independently orders the token flow, from the lowest slot to highest slot, as closely as is allowed by the FDDI rules.

The token flow algorithm ensures that repaired modules return to the same token order that had been assigned prior to the occurrence of a module fault.

NOTE

The token flow algorithm also matches the power shedding algorithm (which sheds modules from slot 1 towards slot 8).

The following examples illustrate the concept of the token flow algorithm:

A.15.2 Example 1 — Token Flow Through Dual Ring Network Modules

Figure A–29 shows a hub that is configured as a dual ring with FDDI network modules in slots 1, 2, 3, 4, 6, and slot 8.

A.15 Token Ordering of Trees or Dual Rings

Figure A-29 Token Flow through Dual Ringed DEChub 900 Modules

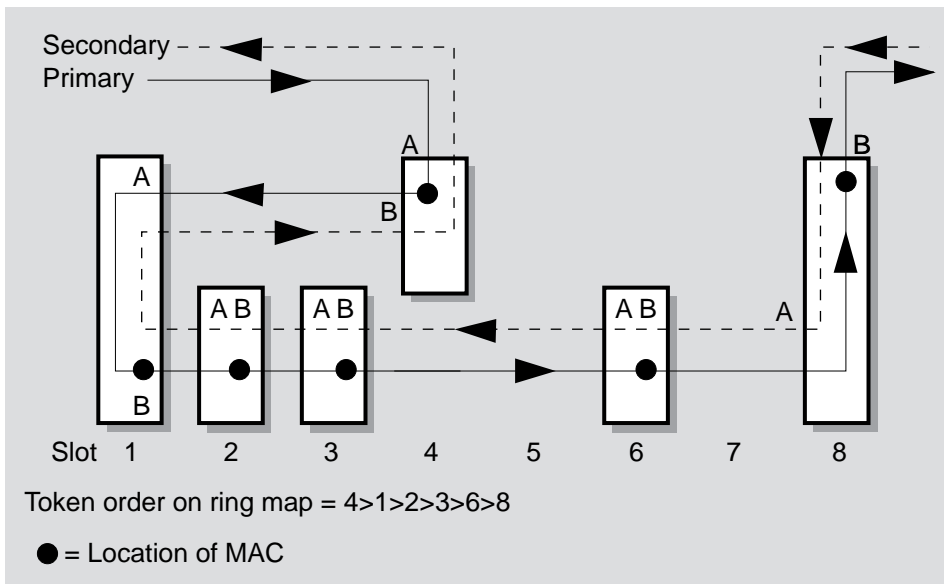

Note that the front panel A port is shown on the module in slot 4, and the B port is shown on the module in slot 8. Therefore, the token, which is flowing on the primary ring, enters the hub at slot 4 and exits from slot 8.

A ring map, showing the order of token flow, is based on the ordering of the MACs in the ring. In this example, MultiChassis Manager configures the backplane so that the token enters the A port of slot 4, encounters the MAC for slot 4, and the next MAC it sees is in slot 1. The token then flows, in order, through the MACs in slots 1, 2, 3, 6, and finally slot 8. Therefore, a ring map records the token order as: 4>1>2>3>6>8.

To accomplish this ordering, the Hub Manager automatically connects the B port of Slot 4 to the A port of Slot 1. The process is repeated for the other modules, so that the token always flows in the correct order.

A.15 Token Ordering of Trees or Dual Rings

A.15.3 Example 2 — Token Flow Through Treed Network Modules

Figure A-30 shows the same hub that is now configured into a tree configuration with FDDI network modules in slots 1, 2, 3, 4, 6, and 8.

Figure A-30 Token Flow through Treed DEChub 900 Modules

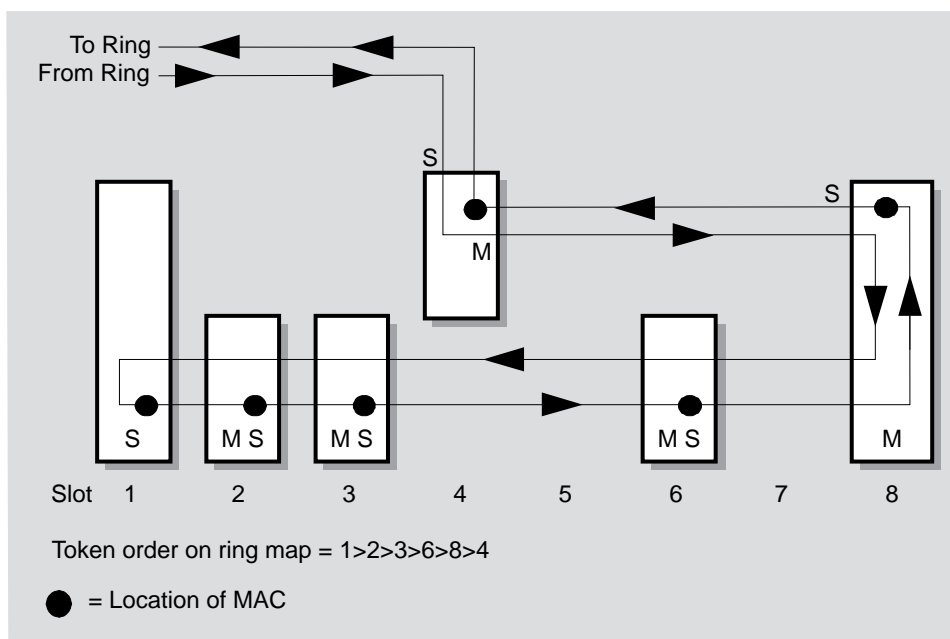

Note that the front panel S port is shown on the module in slot 4, therefore the token enters and exits the hub at slot 4.

A ringmap, showing the order of token flow, is based on the ordering of the MACs in the ring. FDDI rules require that a station's MAC be located immediately prior to the port where the token exits the station. The token enters the S port of slot 4 and flows, in order, through the MACs in slots 1, 2, 3, 6, 8 and finally slot 4. To do this, the S port of slot 8 must connect to the M port of slot 4.

In this example a ring map records the token order as: 1>2>3>6>8>4.

A.16 Quick PC Trace Option for Concentrators

A.16 Quick PC Trace Option for Concentrators

A Quick PC Trace option is supported for all DEChub FDDI concentrator modules.

A.16.1 PC Trace Description

As defined by the FDDI standard, PC Trace is a method for recovering from a stuck beacon condition. All stations that are in the fault domain perform some level of hardware diagnostic test before attempting to reenter the FDDI network.

Normally, concentrator modules run their full set of hardware diagnostics. This takes approximately one minute, but gives the highest level of assurance that any hardware failure would be found.

Quick PC Trace Description

To decrease the recovery time following a trace, the quick PC Trace option has been added. When this option is enabled, only a subset of the hardware diagnostics is run whenever a PC Trace occurs. The reduced set of diagnostic tests completes in approximately 10 seconds. This feature can be enabled and disabled only from the configuration screen of the module's setup port.

NOTE

The DECswitch 900EF and the PEs switch 900TX do not have this optional feature because they normally recover from PC Traces very rapidly (less than 10 seconds). This is because they are FDDI end stations and have a much smaller set of FDDI-specific diagnostics to run than an FDDI concentrator.

A.17 Summary of Important Configuration Features

A.17 Summary of Important Configuration Features

This section reviews the FDDI configuration features for the DEChub 900 FDDI network modules.

A.17.1 Support for Dual Ring and Tree Connections

All DEChub FDDI modules support dual ring connections (A and B ports) and tree connections (M and S ports) across the DEChub 900 MultiSwitch backplane, or out of the front panel of individual FDDI network modules that are configured into a DEChub 900 MultiSwitch.

ALL DEChub FDDI network modules support dual ring connections (A and B ports) and tree connections (M and S ports) when configured standalone into a DEChub ONE or DEChub ONE-MX docking station.

NOTE

The PEs witch 900TX module does not have front panel ports and requires a DEChub ONE-MX docking station, with appropriate ModPMDs, for standalone FDDI connections.

A.17.2 Support for Multiple Independent FDDI Networks

Multiple independent FDDI networks (trees and/or dual rings) are supported across the backplane of the DEChub 900.

A.17.3 Support for Automatic Healing Patch-Around for Failed Modules

An automatic healing capability to patch around failed modules is supported for both trees and dual rings across the backplane of the DEChub 900.

A.17.4 Support for Quick PC Trace Capability

A Quick PC Trace capability has been added to concentrators, to minimize the time it takes to return to operation following a PC Trace. This option is selectable from the module setup screens, whether the module is installed in a DEChub 900, a DEChub ONE, or a DEChub ONE-MX.

A.17 Summary of Important Configuration Features

A.17.5 Dual Ring of Trees Topology

DEChub 900s can participate in a dual ring of trees topology as either part of the dual ring or as part of the tree. For example, a dual ring of trees can be constructed by first building a dual ring, then a tree, and connecting them together with a cable on the front panel (see Figure A-31).

Figure A-31 Legal Dual Ring of Trees Topology

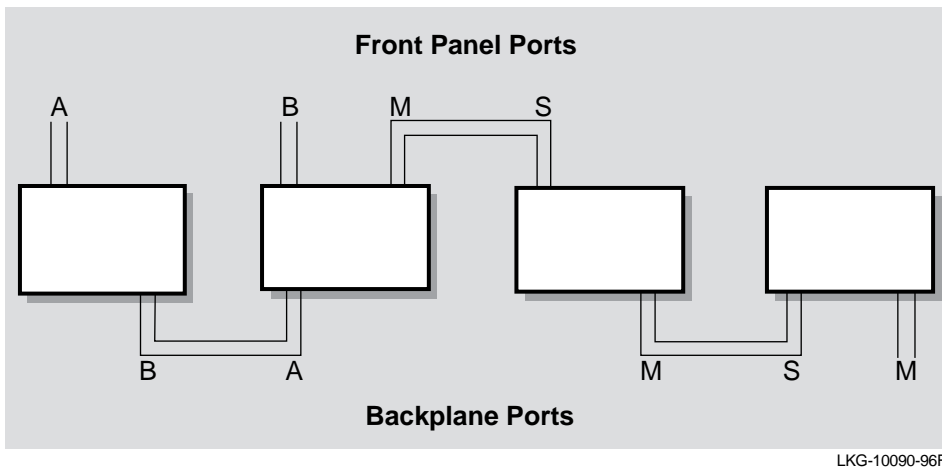

Note that while the connections are all in one network, MultiChassis Manager manages the connections as though they are in unconnected LANs.

A dual ring of trees is not supported across the backplane. Figure A-32 illustrates an illegal or unsupported dual ring of trees topology.

A.17 Summary of Important Configuration Features

Figure A-32 Illegal Dual Ring of Trees Topology

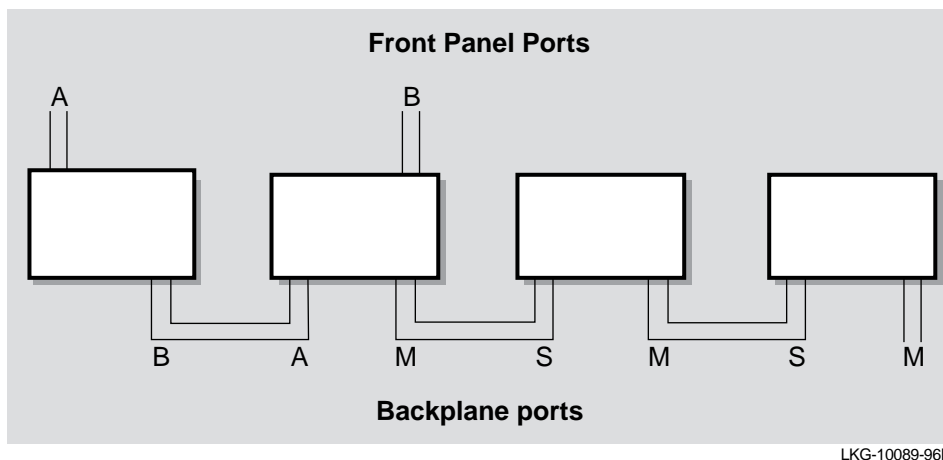

A.17.6 Dual Homing

Dual-homing to multiple FDDI modules in a DEChub 900 can be supported in two ways:

- Each module can be individually dual-homed via its front panel ports (assuming the module has front panel ports)
- One concentrator module can be dual-homed and the other FDDI modules can be treed off that concentrator

A.17.7 Chaining

Additional DEChubs or standalone FDDI network modules can be chained off any DEChub FDDI network module (including switches) that is configured as a tree building block.

A.17.8 Self-Contained Dual Ring Restriction

Attempting to build a self-contained dual ring configuration in the DEChub with eight FDDI modules will not work. This is because there are 14 backplane channels that can be used for FDDI connections and 16 channels would be required to interconnect 8 modules in a hub-contained dual ring. Note that this configuration can be accomplished with 14 backplane channels *and* one DAS cable between two device's front panel ports.

A.17 Summary of Important Configuration Features

A.17.9 Self-Contained Tree Configuration

You can build a self-contained *tree configuration* in the DEChub 900 with eight FDDI modules. This configuration can be built because it requires only 14 backplane channels.

A.17.10 Network Module Front Panel Default

The FDDI default on the following modules is to the front panel ports:

- DECswitch 900EF
- DECconcentrator 900FH
- DECconcentrator 900MX
- DECconcentrator 900TH

The FDDI default for the PEs switch 900TX is to the backplane FDDI port. This is because there are no front panel FDDI ports on the PEs switch 900TX module. This fact is sometimes overlooked when considering default configurations.

A.17.11 Port Configuration in DEChub ONE-MX

FDDI network modules that are installed in a DEChub ONE-MX can configure their FDDI ports either with MultiChassis Manager, or via an FDDI port configuration menu on the DEChub ONE-MX setup port.

A.17.12 Valid FDDI Configurations

Figure A–33 shows a mixture of DEChub types with various DEChub FDDI network modules to demonstrate the flexibility of the DEChub network products.

A.17 Summary of Important Configuration Features

Figure A-33 Valid FDDI Configurations for DEChub FDDI Modules

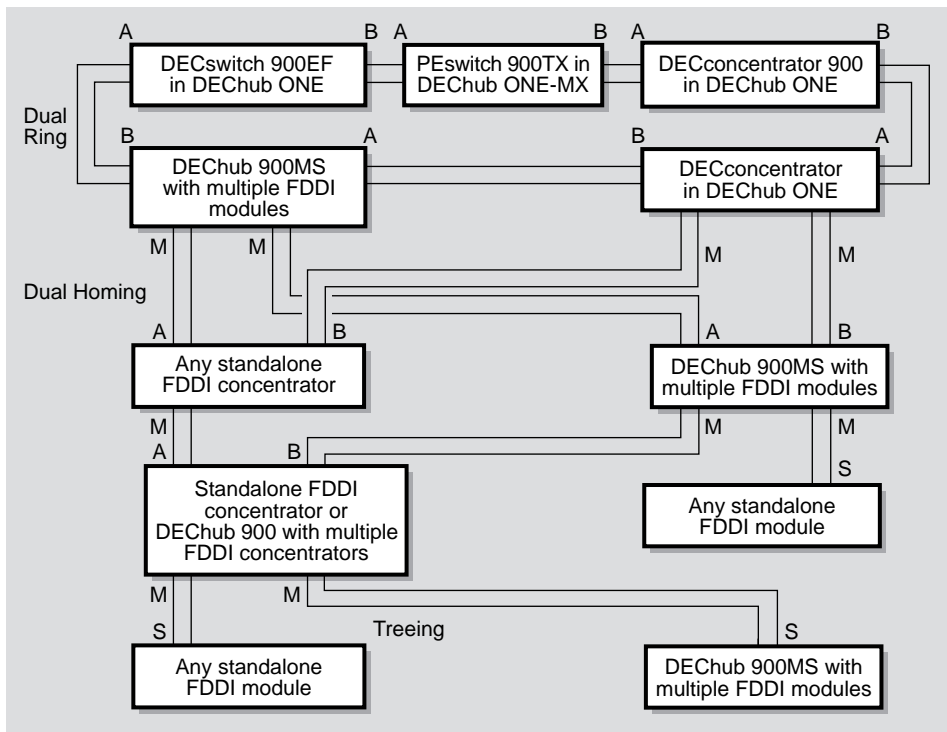

LKG-10094-96F

B.1 The Dual Ring

B

FDDI Overview

Fiber Distributed Data Interface (FDDI) is a set of ANSI/ISO standards for a 100 Mbps token passing ring which uses Multimode fiber, Single mode fiber, Unshielded Twisted Pair, Screened/Shielded Twisted Pair or any combination of the four as the transmission medium. This Appendix provides an overview of the applicable FDDI standards that govern the use of FDDI network modules.

B.1 The Dual Ring

The most basic FDDI network is constructed of two independent rings and is commonly referred to as a dual ring (see Figure B-1). A dual ring connects to each FDDI station in the network. Each ring can span a total distance of up to 100 km, which allows for a distance of up to 200 km (2 x 100 Km/ring) of cabling. As many as 500 stations can be attached to the dual ring — typical configurations usually have no more than 200 stations.

Figure B-1 FDDI Dual Ring

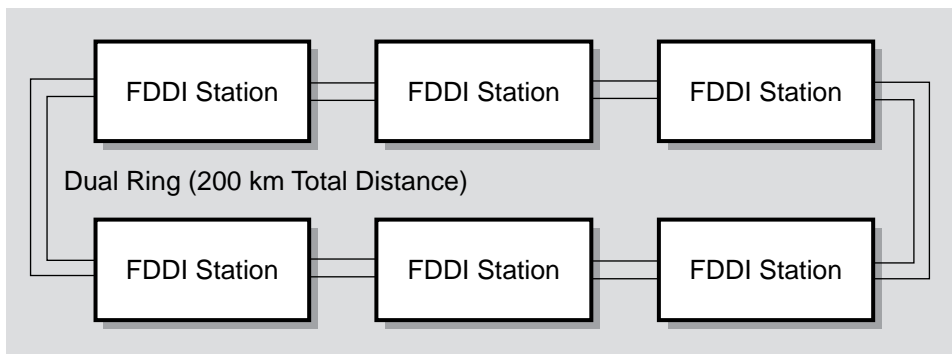

LKG-10095-96F

B.1 The Dual Ring

All FDDI networks operate as logical token rings, where the right to transmit is granted by the possession of a token. There is one token per ring, and it is passed from station to station, according to a set of rules known as the timed token protocol. A station wishing to transmit on the ring first captures the token. It then transmits frames for a period of time determined by the timed token rules, and then releases the token immediately after completing its transmission.

A transmitting station is also responsible for removing the frames it transmitted from the ring, once they have circled the ring and returned to the station. This process is called frame stripping.

B.2 Station Types

B.2 Station Types

B.2.1 FDDI Network Building Blocks

As shown in Figure B-2, FDDI networks are constructed using the following two types of devices:

- Stations — there are two types of stations: Dual Attachment Stations (DAS) and Single Attachment Stations (SAS).
- Concentrators — there are two types of concentrators: Dual Attachment Concentrators (DAC) and Single Attachment Concentrators (SAC).

Figure B-2 FDDI Station Types

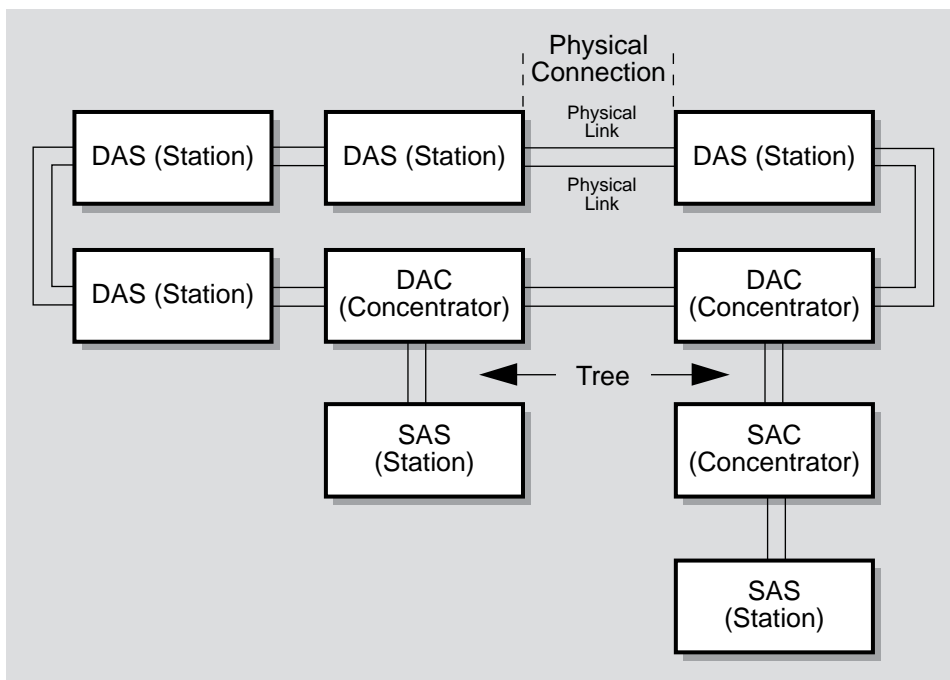

LKG-10096-96F

B.2 Station Types

B.2.2 Dual Attachment Stations

Dual Attachment Stations (DAS) attach directly to the dual ring.

B.2.3 Single Attachment Stations

Single Attachment stations connect to the ring via a concentrator, that can be of two types:

- Dual Attachment Concentrator (DAC) — attaches directly to the dual ring
- Single Attachment Concentrator (SAC) — attaches to the ring through other concentrators.

B.2.4 Physical Connection

As shown in Figure B-2, all devices, whether they are single attachment stations or dual attachment stations, connect to each other via a full-duplex connection, called a physical connection.

Each physical connection comprises two physical links (a single fiber-optic cable per each physical link):

- Single Attachment Stations and Single Attachment Concentrators connect to a concentrator, or to another station, via one physical connection.
- Dual Attachment Stations and Dual Attachment Concentrators connect to each other via two physical connections.

B.3 Media Types and Maximum Distances

B.3 Media Types and Maximum Distances

B.3.1 Important Characteristics

FDDI allows links to be built from the following media types.

Fiber Media	Fiber Type (Microns)	Power Budget (Decibels)	Maximum Link Distance (Kilometers)
Multimode Fiber (MMF)	62.5/125	11	2.0
Single-mode Fiber (SMF)	8-to-10	22	60

Copper Media	Copper Type	Maximum Link Distance
Unshielded Twisted Pair (UTP)	100 ohm Category 5 Twisted Pair	100 meters
Screened Twisted Pair	100 ohm Category 5 Twisted Pair	100 meters
Shielded Twisted Pair	150 ohm Category 5 Twisted Pair (equivalent to IBM Type 1 cable.)	100 meters

B.4 Station Configurations

B.4 Station Configurations

B.4.1 Identifying Stations and Concentrators

Stations and Concentrators (see Figure B-3) can be identified by the types of ports that they use to attach to other stations:

- A and B Ports — Dual Attachment Stations have A and B ports for attachment to other stations in the dual ring, or to concentrator M ports.
- M Port — All concentrators, (SAC or DAC), are identifiable by the presence of M ports. The M port allows the attachment of other stations or concentrators.
- S Port — If the concentrator also has an S port, it is a SAC; if it has A and B ports it is a DAC. A Single Attachment Station has an S port for connection to a concentrator M port.

Figure B-3 FDDI Port Types

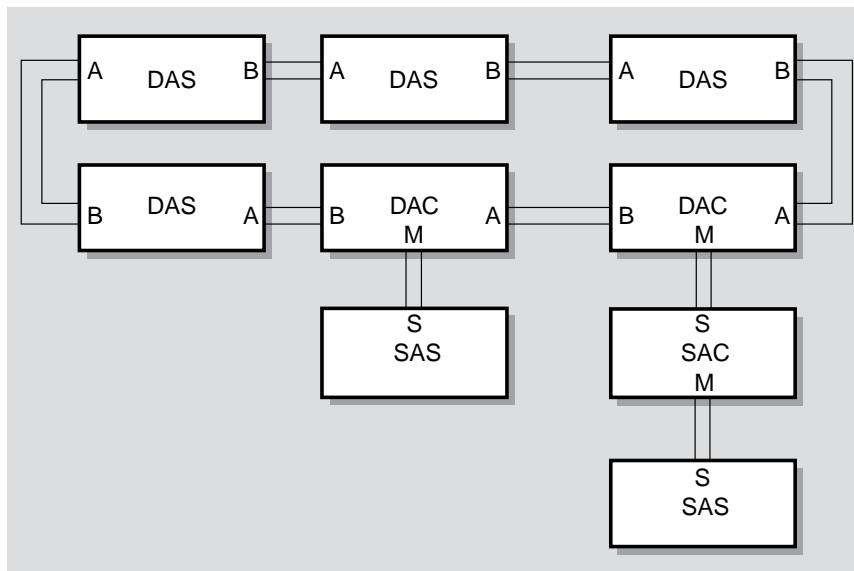

LKG-10097-96F

B.4 Station Configurations

B.4.2 MAC Location

The FDDI rules require that a station's Media Access Control (MAC) be physically located immediately prior to the port where the token exits the station. For Dual Attachment devices this means that the MAC is immediately ahead of the B port; for Single Attachment devices it is immediately ahead of the S port.

B.5 Physical Topologies

B.5 Physical Topologies

B.5.1 Topology Types

Although all FDDI networks are logical rings, the following physical topology types can be created:

- Dual Rings
- Trees
- Dual Ring of Trees

B.5.2 Dual Ring Topologies

Dual Ring topologies (as shown in Figure B-1) are created by connecting only Dual Attachment Stations. The A port of one DAS station connects to the B port of the next DAS station, forming a physical connection between the two stations. The connections can continue until up to 500 stations are included in the dual ring.

- Independent Rings

Because there are two physical links per physical connection (see Figure B-2), two operating links are created between each DAS station when the ring is formed. This design allows for two independent rings, the primary ring and the secondary ring, to be formed.

The Primary ring enters the DAS station at the A port, and exits the DAS station at the B port. The Secondary ring enters the DAS station at the B port and exits the DAS station at the A port.

- Backup Benefit

In general, all data traffic between stations is carried on the primary ring and the secondary ring is idle during this time. The FDDI standards actually allow both rings to be used for carrying data traffic, but in practice this is rarely done. The common practice is to use the secondary ring as a backup for the primary ring.

A benefit of having dual rings is that, in case of a failure, the secondary ring can be used to patch a failure affecting the primary ring. If a station detects that one of its A or B ports has failed, it wraps the primary and secondary rings together, thus restoring operation to the other stations in the ring.

Wrapping occurs very quickly, usually in well under a half a second.

B.5 Physical Topologies

B.5.3 Tree Topologies

FDDI also allows for the creation of tree topologies. Tree topologies start with a stand-alone concentrator at the top of the tree. Stations (DAS or SAS) or other concentrators (DACs) connect to this concentrator, and branch out from the top of the tree.

- How to Identify Trees

The distinguishing feature of a tree topology is the connection to an M port. Single attachment stations (S ports) typically connect to a concentrator, but Dual Attachment Stations (A and B ports) can also connect to the M ports.

- Benefit

A major advantage of the use of trees built with concentrators is the ability of the concentrator to electronically disconnect stations from the ring in case of failure, or, by management control.

B.5.4 Dual Ring of Trees Topology

The third, and most common, FDDI configuration (see Figure B-4) is referred to as the Dual Ring of Trees. This configuration type is a very robust topology and is a hybrid of the Dual Ring and Tree topologies.

Dual Attachment Concentrators (DACs) and Dual Attachment Stations (DASs) attach together in a dual ring, with treed stations connected to the concentrators' M ports. The concentrator connects stations attached to these M ports into the flow of the primary ring.

B.5 Physical Topologies

Figure B-4 FDDI Topologies

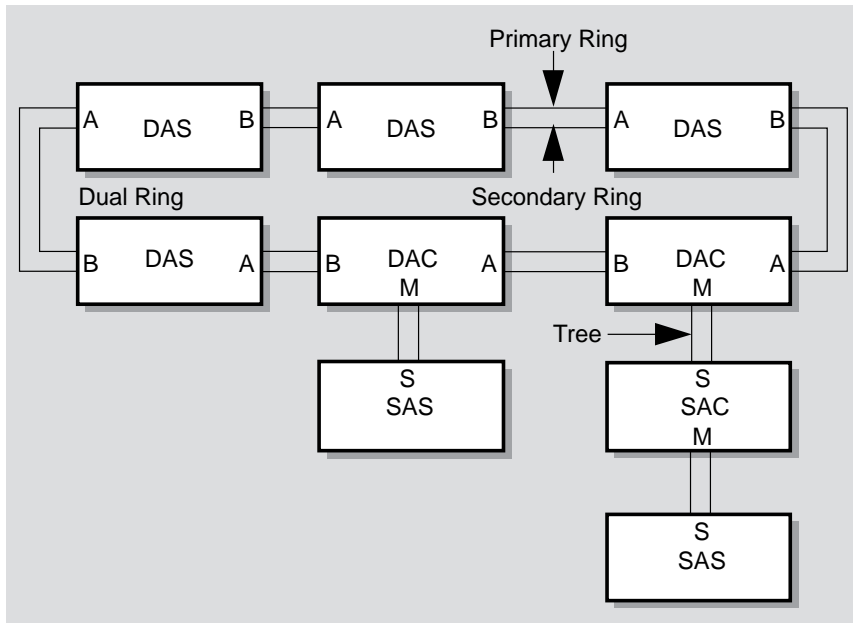

LKG-10098-96F

B.6 Station States

B.6 Station States

B.6.1 Definition

The station state is defined by FDDI standards as: the internal configuration of the paths within the station. Stations can be in one of two states: the Through state or the Wrap state (see Figure B–5).

For example, DAS or DAC stations that are in an (unwrapped) dual ring are in the Through state. If a station detects a failure, causing it to wrap the rings together, that station transitions to the Wrap state.

Figure B–5 Wrapped FDDI Ring

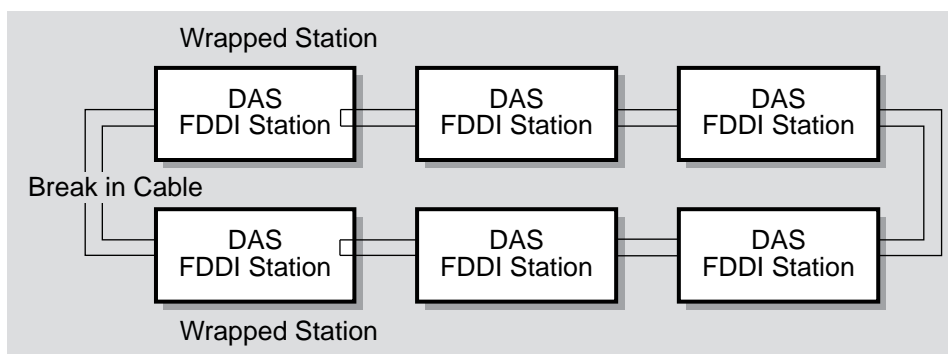

LKG-10099-96F

B.6.2 FDDI Naming Convention

When transitioning to the Wrap state, the station can adjust its internal configuration in a number of ways that are specified by the FDDI standard. The FDDI standard requires that each station configuration type has a specific naming format, and that the station is required to use that specific naming format when reporting internal configuration status to management.

- All Digital SAS and SAC devices report: wrap_S
- All Digital DAS and DAC devices in the wrapped state report: c_wrap_A (concatenated wrap A) or c_wrap_B (concatenated wrap B)

Where c_wrap_A indicates: concatenated wrap A.

To explain further, c_wrap_A means that the B port is not active, the station has wrapped the ring, and the A port is the active port.

B.7 FDDI Connection Rules

B.7 FDDI Connection Rules

B.7.1 Predictability

FDDI connection rules can seem complex and sometimes confusing, however, once clarified and understood, one can easily see how the applied rules prevent the formation of non-useful topologies that can disrupt communications among stations in the ring. FDDI connection rules also ensure that the ring always converges to a pre-defined topology.

For example, as shown in Figure B-6, if Port A (DAC 1) is connected to Port B (DAC 2), and then Port B (DAC 1) is connected to an M-port of (DAC 3), Port A (DAC 1) breaks its connection to Port B (DAC 2).

This behavior is referred to as taking the tree connection over the ring connection. This particular rule ensures that the same tree topology is always formed, independent of the order in which the physical connections are made.

Figure B-6 FDDI Connection Rules

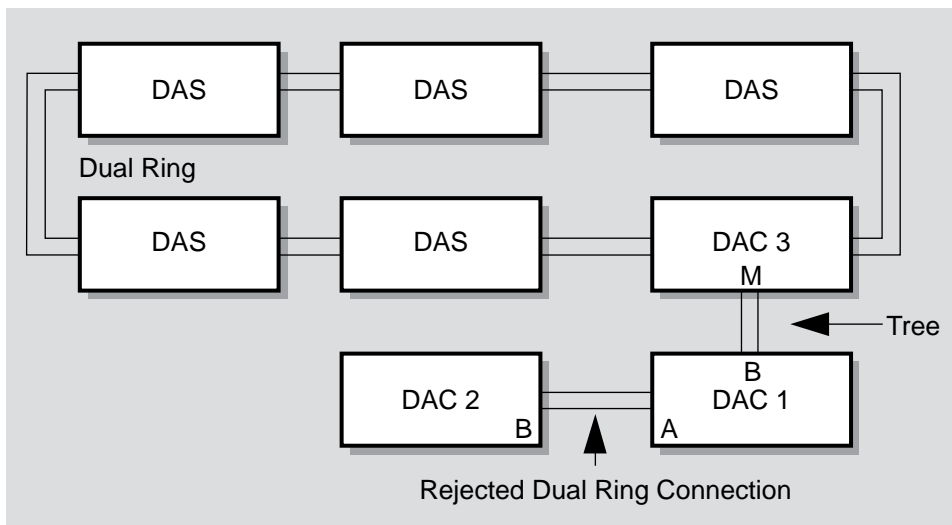

LKG-10100-96F

B.7 FDDI Connection Rules

B.7.2 How Rings are formed

FDDI rings are formed by the completion of physical connections between pairs of ports. The ports signal various parameters that are necessary for the successful completion of the connections.

When a port attempts to form a connection with another port, it indicates both its own port type, and whether it wishes to form a connection with the port type that it senses at the other end of the link.

B.7.3 Undesirable Connections

One type of connection, the M Port-to-M Port connection, is always rejected. Other types of connections, such as A port to A port and B port to B port connections are undesirable, but can be formed if the connection rules of one of the stations allows the connection.

B.7.4 Example

For example, if a Digital FDDI product attempts to form an A port to A port connection with another Digital FDDI product the connection is rejected.

The connection is rejected because Digital products are designed to avoid connection to similar ports (both ports signal that they do not wish to connect to a remote A port).

If the Digital FDDI product attempts to form an A port to A port connection to a non-Digital station, and the non-Digital station's A port signals that it wants to accept the connection to the Digital A port, the Digital station honors the request (per the ANSI standard's rules for connection of ports).

The result of this type of connection is graphically shown in the following subsection.

B.7.5 Result

The resulting configuration (see Figure B-7) is that, although the stations are connected, one station's MAC address is in the primary ring, and the other station's MAC address is in the secondary ring.

Because the rings are isolated when in the Through state (refer to "Station States" on p. B-11), the stations are unable to communicate, even though their ports have formed a valid physical connection.

B.7 FDDI Connection Rules

Figure B-7 Connecting to Similar Ports

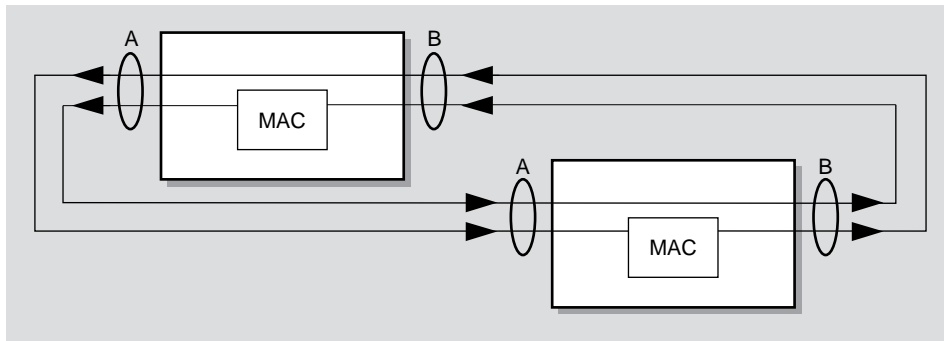

NPB-10021-96F

B.7 FDDI Connection Rules

B.7.6 Summary of FDDI Connection Rules

Table B-1 summarizes the FDDI connection rules.

Table B-1 FDDI Connection Rules and Station States

Port A	Port B	Topology	Station State
M	—	Tree	c_wrap_A
—	M	Tree	c_wrap_B
M	M	Tree	c_wrap_B (Dual Homed)
B	—	Peer ¹	c_wrap_A
—	A	Peer ¹	c_wrap_B
B	A	Peer ¹	Through
A		Peer ¹	c_wrap_A
—	B	Peer ¹	c_wrap_B
S		Peer ¹	c_wrap_A
—	S	Peer ¹	c_wrap_B
S	S	Peer ¹	Through
S	M	Tree	c_wrap_B (Tree Preference) ²
M	S	Tree	c_wrap_A (Tree Preference) ²
S	A	Peer ¹	Through
B	S	Peer ¹	Through
B	M	Tree	c_wrap_B (Tree Preference) ²
M	A	Tree	c_wrap_A (Tree Preference) ²

¹ Indicates dual ring connection.

² Tree topology always takes precedence over ring topology when simultaneous or conflicting connections are made.

B.8 Ring Operation

B.8 Ring Operation

B.8.1 Overview

FDDI rings operate according to the rules of the Timed Token Protocol.

The operation of the ring can be divided into two states:

- Ring Initialization State
- Steady State Operation

B.8.2 Ring Initialization State

The FDDI ring is initialized by a process known as the claim token process, that is invoked whenever a station enters or exits the ring, or if a failure of the normal ring operation is detected. The purpose of the claim token process is to set the operational timers for the ring, and to choose a station that is responsible for creating the token.

B.8.3 The Claim Token Process

All stations send a special frame, known as a claim frame, containing a bid for the length of time that the station is willing to wait between receipt of tokens. The station that wins the bidding is the station whose bid indicates that it needs the token the most often. If the outcome of the bidding indicates a tie, the station with the highest MAC address wins.

The outcome of the claim process is that all stations agree to abide by this time period, which is known as T_Negotiated (T_Neg). Typical values for T_Neg are in the range of 5-10 ms, with 8 ms being a common choice.

Varying the value of T_Neg can dramatically change the utilization and latency of a very busy FDDI ring, but it has minimal affect on the utilization or latency of a lightly loaded ring. Digital recommends not changing the value of T_Neg from the device manufacturer's default setting.

B.8.4 The Beacon Process

If a ring fails to complete the claim process within a certain time, the ring enters the beacon process. The beacon process causes special frames known as beacon frames to traverse the ring in an attempt to isolate the location of the fault.

Understandably, when beacon frames are detected traversing the ring, it usually indicates a serious problem with the operation of the ring.

B.8 Ring Operation

B.8.5 Steady State

In the steady state, the token circulates around the ring. The time for a token to circle once around the ring without being used by anyone is known as the token latency. Stations that wish to transmit must capture the token, and can transmit as long as allowed by the token holding rules.

All stations keep a timer called the valid transmission timer (TVX) which they use for timing valid activity on the ring. If, for any reason, a token gets lost, the TVX timer expires and all stations enter the claim process to elect a new token.

During the Steady State, all stations in the ring exchange frames that report their adjacent stations. This information is communicated via Station Management (SMT) frames, that are sent at a rate of approximately 1 every 10 to 30 seconds.

Using these frames, all stations on the ring determine their upstream and downstream neighbors. For example, Station 2 is said to be downstream of Station 1 if Station 2 receives the token after it was received by Station 1.

C

Accessing Online Information

This appendix describes how to access these products' online release notes, public MIBs, Digital's private MIBs, firmware images, and requests for comments (RFCs).

C.1 Network Product Business Web Site

Further information on these network products and topics is available on Digital's Network Product Business Web Site as well as its Bulletin Board System. Both systems maintain a common, rich set of up-to-date information on NPB's products, technologies, and programs.

The Web Site can be reached at geographic locations via the following URLs:

Americas Network Product Business Home Page
<http://www.networks.digital.com/>

Europe Network Product Business Home Page
<http://www.networks.europe.digital.com/>

Australia Network Product Business Home Page
<http://www.digital.com.au/networks/>

Digital Equipment Corporation Home Page
<http://www.digital.com/>

To get firmware and MIB information, please choose the "Products and Technology" link, and from there choose the "Technical Data" link.

To connect to the Network Product Business Bulletin Board System, you need a PC and a modem. Dial 508-486-5777 (U.S.A.). Set your modem to 8 bits, no parity, 1 stop bit.

C.2 Using Electronic Mail

The DDN Network Information Center (NIC) of SRI International provides automated access to NIC documents and information through electronic mail. This is especially useful for users who do not have access to the NIC from a direct Internet link, such as BITNET, CSNET, or UUCP sites.

C.2 Using Electronic Mail

To use the mail service, follow these instructions:

1. Send a mail message to **SERVICE@NIC.DDN.MIL**.
2. In the SUBJECT field, request the type of service that you want followed by any needed arguments.

Normally the message body is ignored, but if the SUBJECT field is empty, the first line of the message body is taken as the request.

The following example shows the SUBJECT lines you use to obtain DDN NIC documents:

```
HELP
RFC 822
RFC INDEX
RFC 1119.PS
FYI 1
IETF 1IETF-DESCRIPTION.TXT
INTERNET-DRAFTS 1ID-ABSTRACTS.TXT
NETINFO DOMAIN-TEMPLATE.TXT
SEND RFC: RFC-BY-AUTHOR.TXT
SEND IETF/1WG-SUMMARY.TXT
SEND INTERNET-DRAFTS/DRAFT-IETF-NETDATA-NETDATA-00.TXT
HOST DIIS
```

Requests are processed automatically once a day. Large files are broken into separate messages.

Glossary

This glossary contains definitions for DEChub and MultiStack terms and acronyms used in this manual.

8-pin MJ connector

A jack used for connecting a cable terminated with an 8-pin MJ-compatible (RJ45) plug.

access server

A module that allows a terminal to connect to a network node.

active port

A redundant repeater port over which communication is currently taking place. An active port is enabled and handles any communication between the connected repeater ports.

address filtering

A feature that allows you to prevent, on a per-port basis, a bridge from forwarding frames specified by source and destination addresses.

agent

A task running on the object being managed. The agent responds to requests for information by the network management station (NMS). An SNMP agent is responsible for performing GET and SET operations, for generating the appropriate traps, and controlling access.

agents file

Contains a list of Simple Network Management Protocol (SNMP) agents that can be used to manage hubs and network modules.

alarms

Conditions in a hub or a community that the alarms software monitors. The conditions are detected by polling a predetermined list of MIBs on each type of network module. When a MIB value changes, the alarms software generates an alarm.

attachment unit interface (AUI)

A 15-pin “D”-sub connector interface that allows stations to connect to the Ethernet\IEEE 802.3 network.

authorized station

An addressable node on a local area network (LAN) that is capable of transmitting, repeating, and receiving data.

autodiscovery

The capability of the hub chassis and its associated firmware to detect, identify, and configure certain network modules when they are installed in the hub. Modules that the hub cannot autodiscover must be manually added to the hub’s configuration using either the hub’s console setup port or the clearVISN Add Module window.

autopartition

To automatically disable a repeater port. The autopartition algorithm protects the network from certain fault conditions that would halt all LAN communications, for example, a media short or break, a faulty connector, or faulty or missing media termination.

If it detects such faults on any of its ports, the repeater isolates the faulty segment from the network.

A repeater does not respond to input received from an autopartitioned port, except to determine whether or not the fault condition has been removed. However, a repeater continues to transmit data to an autopartitioned port.

backbone

A core network (usually high speed) to which multiple local area networks (LANs) are connected, often using bridges or routers, and over which traffic can pass.

bandwidth

A measure of the amount of traffic the media can handle at one time. In digital communications, bandwidth describes the amount of data, in bits per second, that can be transmitted over the line.

BootP

A protocol that is used by a network node to determine the Internet Protocol (IP) address of its Ethernet interfaces used for network booting.

bridge (or MAC Bridge)

An intelligent, protocol-independent, store-and-forward device that operates as a Data Link layer relay. Used to connect similar or dissimilar local area networks (LANs). A collection of LANs connected by bridges is referred to as an Extended LAN.

brouter

A bridge with minimal routing capabilities. In general, a brouter can deliver least-cost routing; some can also deliver minimal-load balancing.

CF state

The CF state displays the current path configuration of the A and B ports.

chassis

The physical housing of the hub.

community

A set of attributes that are managed as a group. Community names are used in SNMP to control access. Each SNMP software request contains a community name that the agent uses as a password to verify that the requester is authorized to access the agent's management information base (MIB) or a subset of that MIB.

Community names indicate whether or not the requester has read-only or read-write authority.

In Digital's implementation, MIBs are defined by the agent.

community string

A text string, also referred to as a community name, that is used as a password by an SNMP agent to authenticate or verify that the network management station (NMS) making the request is allowed access to the contents of the agent's management information base (MIB).

concentrator

The FDDI concentrator is a physical layer repeating device that allows the attachment of multiple single attachment stations, dual attachment stations, or other concentrators to the FDDI network.

DECnet

Digital networking software that runs on nodes in both local-area and wide-area networks.

Data-Set-Ready (DSR)

When set, a control signal that indicates to the data terminal equipment that the local modem is connected to the channel and is ready to receive data or to accept a request to transmit.

Data-Terminal-Ready (DTR)

A control signal that enters a modem from the data terminal or communications device that is using the modem. When the signal is set, it informs the modem that the data terminal equipment is ready to receive and transmit data.

DECnet address

A series of numbers that identifies a device's location in the DECnet network.

DECnet name

A unique alphanumeric string that identifies a device on the DECnet network.

device

A network element that is external to the hub or computer equipment (such as a printer, terminal, or personal computer (PC)) that is attached to an access server port.

double hub

Two DEChub 90 hubs daisy-chained together. A double hub is treated as a single hardware device and is represented by a single community.

downline load

The process of sending a software image from a load host to the bridge.

dual attachment station (DAS)

An FDDI station that offers two connections to the FDDI dual counter-rotating ring.

Ethernet

A network communications system developed and standardized by Digital, Intel, and Xerox, using baseband transmission, CSMA/CD access, and logical bus topology. This industry-standard protocol is specified by ISO 8802-3 ANSI/IEEE Standard 802.3.

Ethernet station

An addressable node on an Ethernet network capable of transmitting and receiving data. An Ethernet station must contain a MAC.

failover

The feature that causes a failed link to automatically reconfigure to a redundant or “backup” link.

FDDI port connector type

A variable that specifies the type of port. The four different port connector types are:

A - The port is a dual attachment station or concentrator that attaches to the primary in and the secondary out when attaching to the dual ring.

B - The port is a dual attachment station or concentrator that attaches to the secondary in and the primary out when attaching to the dual ring.

S - Either one port in a single attachment station, or one port in a single attachment concentrator.

M - A port in a concentrator that serves as a master to a connected station or concentrator.

FDDI station

A node on an FDDI ring capable of transmitting, receiving, and repeating data. A station has one instance of SMT, at least one instance of PHY and PMD, and an optional MAC entity.

Fiber Distributed Data Interface (FDDI)

A set of ANSI/ISO standards that define a high-bandwidth (100-Mb/s), general-purpose, shared, local area network (LAN) connection between computers and peripheral equipment in a timed-passing, dual ring-of-trees configuration.

filtering

Filtering allows you to prevent, on per-port basis, a bridge from forwarding frames specified by address or protocol.

flex(ible) channel

A technology independent high-bandwidth channel that can support FDDI, Ethernet, Token Ring, or other interconnection needs. The DEChub 90 has one flex channel.

The DEChub 900 has one flex channel on the upper (48-pin connector) and twelve flex channels (actually fourteen, because channels 11 and 12 are each segmented into two distinct channels) on the lower (160 pin connector).

flow control

An access server port characteristic that allows an access server to start and stop data transfer between the access server port and the attached device.

FOIRL

Fiber-optic inter-repeater link.

forwarding database (address forwarding database)

A table maintained by a bridge (see bridge) that contains station addresses, the port on which the addresses are located, and the age of these entries. A bridge forwards or filters frames based on the information in the forwarding database. A bridge creates its forwarding database by “learning” the source line and source address of each incoming frame.

frame

A group of digits (bits) transmitted as a unit, over which a coding procedure is applied for synchronization. Frames are transmitted in packets on an Ethernet LAN.

FRU

Field replaceable unit.

full height module

A six-sided enclosure measuring approximately 1.73 inches x 17.5 inches x 6.0 inches. This module is installable in the DEChub 900, DEChub ONE, or DEChub ONE-MX.

GET

A Simple Network Management Protocol (SNMP) request in which the named instance is retrieved if the community string matches. If the community string does not match, an error is returned.

half height module

A six-sided enclosure measuring approximately 1.25 inches x 10.5 inches x 4.5 inches. This module is installable in the Digital MultiStack System, DEChub 90, or DEChub 900.

hot swap

To “hot swap” a component means to remove and replace it while the system is in operation.

hub

A central device, usually in a star topology local area network (LAN), to which stations and other devices are connected.

Hub Manager

An integrated microprocessor-based controller used to monitor, configure, and control the hub. Either under remote management control or default local control, the Hub Manager provides a central point for allocation of hub resources to hub-mounted network modules.

IEEE

Institute of Electrical and Electronics Engineers.

in-band management

Managing a device over a network.

Internet Protocol (IP)

The network protocol offering a connectionless-mode network service in the Internet suite of protocols.

Internet Protocol (IP) address

The IP address is a series of numbers that identifies a device’s network address on the Internet.

Internet Protocol (IP) forwarding

The forwarding of IP packets between interfaces (ports) on a DECserver 90TL, 90M, or 900TM.

Internet Protocol (IP) name

A unique alphanumeric string that identifies a device on the Internet.

LAN

See local area network (LAN).

LAT

See local area transport (LAT).

LAN segment

A portion of the LAN of a single media type, that is organized in a bus, a ring, or a point-to-point configuration.

LED

See light emitting diode (LED)

light-emitting diode (LED)

An indicator of status on a network module.

local area network (LAN)

A data communications network that spans a limited geographical area. The network provides high-bandwidth communication over coaxial cable, twisted-pair, fiber, or microwave media and is usually owned by the user.

local area transport (LAT)

A communications protocol used in a local area network.

MAC address

A unique 48-bit binary number (usually represented as a 12-digit hexadecimal number) encoded in a device's circuitry to identify it on a local area network. These are unique and assigned by IEEE 802.

Maintenance Operation Protocol (MOP) session

A logical connection using the Maintenance Operation Protocol (MOP).

management agent

See SNMP agent.

management information base

A dynamic, virtual collection of data about a managed object. The managed object provides this data to the network management station (NMS) which gathers the values from the managed object and loads them into the MIB representing the object.

master mode

A pair of repeater ports (primary and secondary) that control a redundant link. Because the remote ports, or responder ports, to which the master ports are connected must be on the same LAN or are otherwise bridged together, only one of the master ports may be enabled at a time.

MAU (Ethernet)

Media Access Unit. When used in the context of network modules such as repeaters and PORTswitches, this acronym stands for media access unit. These devices convert the standard AUI to media types such as UTP, fiber optic, or ThinWire.

MAU (Token Ring)

When used in the context of token ring LANs and modules, this acronym stands for multistation access unit.

MIB

See Management Information Base.

MMJ connector

A jack used for connecting an EIA 423 data cable to a DECserver 90L or 90L+.

module

An interchangeable unit that provides functionality and interconnection to a local area network (LAN) through the hub.

See also network modules.

MOP

Maintenance Operation Protocol.

multiswitch backplane

A backplane that allows flexible allocation of its signals so that multiple local area network (LAN) segments can be managed. The DEChub 900 MultiSwitch has a multiswitch backplane.

network

A collection of computer access terminals, and other devices together with the hardware and software that enables them to exchange data and share resources over either short or long distances.

network management

In the OSI model, the five functional application areas of accounting management, configuration management, fault management, performance management, and security management.

network management application

A collection of software tools that provides information about the network by communicating with agent software in the managed objects.

network management station (NMS)

A PC or OpenVMS workstation equipped with an Ethernet, FDDI, or Token Ring network module and clearVISN software, which enables it to communicate with and manage network modules.

network modules

Any modular devices that provide network connectivity or services that can be installed in a DEChub backplane, Digital MultiStack System, docking station, or used standalone. These include, but are not limited to, repeaters, concentrators, bridges, routers, access servers, switches, and SNMP agents.

NVRAM

Nonvolatile random access memory.

out-of-band management (OBM)

Management of a network module or device over a telephone line or direct line to a dedicated management port, rather than sending management traffic over the network.

partition

A repeater port is said to be partitioned when its management is disabled or autopartitioned.

PC

Personal computer.

PHY

A Fiber Distributed Data Interface (FDDI) standard that defines symbols, line states, clocking requirements, and the encoding of data for transmission.

physical layer medium dependent

FDDI standards that define the media and protocols to transfer symbols between adjacent PHYs.

physical topology

The arrangement of cables and hardware that make up the network.

PMD

Physical layer medium dependent.

primary port

A redundant master repeater port that is placed in the active state when redundant ports are configured.

protocol

A formal set of rules governing the format, timing, sequencing, and error control of exchanged messages on a data network. A protocol may also include facilities for managing a communications link or contention resolution.

A protocol may relate to data transfer over an interface, between two logical units directly connected, or on an end-to-end basis between two end users over a large and complex network. There are hardware protocols and software protocols.

Protocol Data Unit (PDU)

A data object exchanged by protocol layers that contains both protocol control information and user data.

protocol filtering (MAC layer)

A feature in some bridges that can be programmed to forward or reject transmissions that are originated under specified MAC protocols.

proxy access

The way a proxy Simple Network Management Protocol (SNMP) agent provides requests to the network management station (NMS). A proxy agent acts on behalf of network devices that do not support SNMP. When such a network module is to be managed, the NMS contacts the proxy agent and indicates the identity of the network module.

proxy agent

The proxy agent translates the protocol interactions it receives from the network management station into whatever interactions are supported by the network module.

rate limit

The total number of frames on all ports allowed by a bridge per second.

repeat

An action in which a station receives a frame or token from an upstream station, retimes it, and places it onto the ring for its downstream neighbor. The repeating station can examine, copy to a buffer, or modify control bits in the frame, as appropriate.

repeater

A level 1 hardware device that restores signal amplitude, waveform, and timing of signals before transmission to another network segment.

responder mode

This mode designates ports that connect to master mode ports. Responder ports are always enabled but are active only when their master port is active. A key function of the responder port, other than receiving and transmitting data, is to report link failures to the master port. When the master port detects a link failure, it causes the link to failover to the standby link. If the standby link is not available when the active link fails, the failover process waits until it is available. If the previously active link becomes available during this waiting period, the master returns to using it. Otherwise, the failover to the standby link takes place as soon as the standby link is good. Thus, the highest utilization possible on a dual-port redundant link is achieved.

responder port

A redundant repeater port that connects to either a master primary or a secondary port. Because responder ports are always enabled, no action is taken to switch ports in case of link failure. However, a responder port does detect and report link failures to its partner (master primary or master secondary) port by continuously pulsing its fiber transmit LED on and off. If the master port connected to the responder port is active, the responder port treats this event as a link failure and causes a link failover.

Link failures include the following conditions:

- Autopartitioning
- Management disable
- Carrier loss

RFC

Request for Comments. A series of documents describing the Internet suite of protocols.

ring

Connection of two or more stations in a circular logical topology. Information is passed sequentially between active stations, where each one, in turn, examines or copies the data, and returns it to the originating station, which removes the data from the network. FDDI is a ring topology.

secondary port

A redundant master repeater port that is placed in the standby state when redundant ports are configured.

Serial Line Internet Protocol

Used for transmitting Internet Protocol (IP) packets across serial lines.

server

A network node or specialized device that provides and manages access to shared network resources, such as hard disks, printers, and software.

service node

A node to which a terminal is able to establish a session through an access server port.

session

A logical connection between a terminal and a service node.

SET

A Simple Network Management Protocol (SNMP) request in which the named instance is modified if the community string matches.

shielded twisted-pair

A cable composed of two insulated wires, twisted together and surrounded by a braided metal shield or foil under the outer insulation.

Simple Network Management Protocol (SNMP)

A high-level, standards-based protocol for network management, usually used in TCP/IP networks.

Simple Network Management Protocol (SNMP) agent

An entity in a hardware device that executes SNMP requests.

single attachment station (SAS)

An FDDI station that offers one S port for attachment to the FDDI ring.

single hub

An eight-slot hub. A double-hub is two single hubs daisy-chained together.

SLIP

See Serial Line Interface Protocol.

SNMP MIB-II

The Management Information Base (MIB-II) for use with network management protocols in TCP/IP-based internets.

See Request for Comments (RFC) 1213.

split speed

A DECserver 90TL's, 90M's, or 900TM's port characteristic of having different input and output speeds.

stack manager

A proxy agent installed in a Digital MultiStack System.

standalone module

A network module in a single configuration such as a DEChub ONE.

standby port

A redundant repeater port that is configured as a backup port to an active port. A standby port is disabled and is held in readiness in case the active port fails.

Telnet

The TCP/IP standard protocol for remote terminal connections. Using Telnet, a user at one site can connect to a timesharing system at another site as if the user's terminal is connected directly to the remote machine. The user invokes a Telnet application program that connects to a remote machine, prompts for a login ID and password, and then passes keystrokes from the user's terminal to the remote machine.

terminal server

A module that allows a terminal to connect to a network node. See also access server.

token ring

A network with a ring topology that passes data-bearing tokens from one attached station to the next. The original protocol developed by IBM was succeeded by the IEEE 802.5 standard for token ring network communications.

topology

The logical or physical arrangement of nodes on a network.

Transmission Control Protocol (TCP)

The transport protocol offering a connection-oriented transport service in the Internet suite of protocols.

User Datagram Protocol (UDP)

The protocol offering a connectionless-mode transport service in the Internet suite of protocols.

Index

A

Audience

intended, ix

B

Backplane healing

dual ring configurations, A-31

tree configurations, A-33

Beacon process, B-16

Book structure, x

Bridge Modules

half-height, 2-8

selecting, 2-8

Bridge Router Modules

selecting, 2-12

Bridge Routers

description, 3-59

Bridges

description, 3-38

Brouter Modules

selecting, 2-12

Brouters

description, 3-59

Building blocks, FDDI, A-11

C

Chaining, A-41

Cisco backbone

connecting to, 6-27

Claim token process, B-16

clearVISN, 5-1

applications, 5-2

management applications, 5-2

Concentrator Modules

selecting, 2-11

Concentrators

description, 3-65

Configuration

FDDI dual ring, A-4

FDDI guidelines, A-2

tree, A-5

Connections, point-to-point, A-3

D

DECagent 90

description, 3-91

IP service, 3-93

LAN connectivity, 3-92

manageability, 3-92

media, 3-92

platforms supported, 3-91

protocol, 3-92

supported MIBs, 3-92

upgrade method, 3-92

- DECbridge 90
 - description, 3-39
 - IP service, 3-40
 - LAN connectivity, 3-40
 - manageability, 3-40
 - media, 3-40
 - platforms supported, 3-39
 - protocol, 3-40
 - supported MIBs, 3-40
 - upgrade method, 3-40
- DECbridge 90FL
 - description, 3-42
 - LAN connectivity, 3-43
 - manageability, 3-43
 - media, 3-43
 - platforms supported, 3-43
 - protocol, 3-43
 - supported MIBs, 3-43
 - upgrade method, 3-43
- DECbrouer 90T1
 - description, 3-59
 - IP service, 3-61
 - LAN connectivity, 3-60
 - manageability, 3-61
 - media, 3-60
 - platforms supported, 3-60
 - protocol, 3-60
 - supported MIBs, 3-61
 - upgrade method, 3-61
- DECbrouer 90T2
 - description, 3-59
 - IP service, 3-61
 - LAN connectivity, 3-60
 - manageability, 3-61
 - platforms supported, 3-60
 - protocol, 3-60
 - supported MIBs, 3-61
 - upgrade method, 3-61
- DECbrouer 90T2A
 - description, 3-59
 - IP service, 3-61
 - LAN connectivity, 3-60
 - manageability, 3-61
 - platforms supported, 3-60
 - protocol, 3-60
 - supported MIBs, 3-61
 - upgrade method, 3-61
- DECbrouers
 - comparison, 3-59
- DECconcentrator 900FG
 - upgrade method, 3-72
- DECconcentrator 900FH, A-8
 - description, 3-71
 - IP service, 3-73
 - LAN connectivity, 3-72
 - manageability, 3-72
 - media, 3-72
 - platforms supported, 3-72
 - port assignments, A-8
 - protocol, 3-72
 - supported MIBs, 3-72
- DECconcentrator 900MX, A-6
 - description, 3-65
 - IP service, 3-67
 - LAN connectivity, 3-66
 - manageability, 3-67
 - media, 3-66
 - platforms supported, 3-66
 - port assignments, A-6
 - protocol, 3-66
 - upgrade method, 3-67
- DEconcentrator 900MX
 - supported MIBs, 3-67
- DECconcentrator 900TH, A-7

- description, 3-68
- IP service, 3-70
- LAN connectivity, 3-69
- manageability, 3-69
- media, 3-69
- platforms supported, 3-69
- port assignments, A-7
- protocol, 3-69
- supported MIBs, 3-70
- upgrade method, 3-69
- DEChub 90
 - description, 1-2
 - features, 1-2
 - in-band management, 4-2, 4-5
 - out-of-band management, 4-8
- DEChub 900
 - backplane, A-3
 - description, 1-4
 - features, 1-6
 - in-band management, 4-2, 4-6
 - out-of-band management, 4-8
- DEChub ONE
 - change of environment, A-15
 - description, 1-9
 - in-band management, 4-2
 - power failure recovery, A-15
- DEChub ONE-MX
 - change of environment, A-15
 - description, 1-10
 - enabling ModPMD ports, A-15
 - in-band management, 4-2
 - ModPMDs, A-15
 - power failure recovery, A-15
- DECmau 900TH
 - description, 3-95
 - IP service, 3-96
 - LAN connectivity, 3-96
 - manageability, 3-96
 - media, 3-96
 - platforms supported, 3-95
 - protocol, 3-96
 - supported MIBs, 3-96
 - upgrade method, 3-96
- DECpacketprobe 90
 - description, 3-107
 - IP service, 3-109
 - LAN connectivity, 3-108
 - manageability, 3-108
 - media, 3-108
 - platforms supported, 3-108
 - protocol, 3-108
 - supported MIBs, 3-109
 - upgrade method, 3-108
- DECpacketprobe 900RR
 - description, 3-110
 - IP service, 3-111
 - LAN connectivity, 3-111
 - manageability, 3-111
 - media, 3-110
 - platforms supported, 3-110
 - protocol, 3-110
 - supported MIBs, 3-111
 - upgrade method, 3-111
- DECrepeater 900FL
 - description, 3-105
 - platforms supported, 3-105
 - protocol, 3-105
- DECrepeater 900GM
 - description, 3-11
 - IP service, 3-13
 - LAN connectivity, 3-12
 - manageability, 3-12
 - media, 3-12
 - platforms supported, 3-11

- protocol, 3-12
- supported MIBs, 3-12
- upgrade method, 3-12
- DECrepeater 900SL
 - description, 3-101
 - IP service, 3-102
 - LAN connectivity, 3-101
 - manageability, 3-102
 - media, 3-101
 - platforms supported, 3-101
 - protocol, 3-101
 - supported MIBs, 3-102
 - upgrade method, 3-102
- DECrepeater 900TL
 - description, 3-103
 - IP service, 3-104, 3-106
 - LAN connectivity, 3-103, 3-105
 - manageability, 3-104, 3-106
 - media, 3-103, 3-105
 - platforms supported, 3-103
 - protocol, 3-103
 - supported MIBs, 3-104, 3-106
 - upgrade method, 3-104, 3-106
- DECrepeater 900TM
 - description, 3-14
 - IP service, 3-16
 - LAN connectivity, 3-15
 - manageability, 3-15
 - media, 3-15
 - platforms supported, 3-14
 - protocol, 3-14
 - supported MIBs, 3-15
 - upgradeability, 3-15
- DECrepeater 90C
 - description, 3-25
 - IP service, 3-26
 - LAN connectivity, 3-26
 - manageability, 3-26
 - media, 3-26
 - platforms supported, 3-25
 - protocol, 3-25
 - supported MIBs, 3-26
 - upgrade method, 3-26
- DECrepeater 90FA
 - description, 3-17
 - IP service, 3-19
 - LAN connectivity, 3-18
 - manageability, 3-18
 - media, 3-18
 - platforms supported, 3-18
 - protocol, 3-18
 - supported MIBs, 3-19
- DECrepeater 90FL
 - description, 3-20
 - IP service, 3-21
 - LAN connectivity, 3-21
 - manageability, 3-21
 - media, 3-20
 - platforms supported, 3-20
 - protocol, 3-20
 - supported MIBs, 3-21
 - upgrade method, 3-21
- DECrepeater 90FS
 - description, 3-22
 - IP service, 3-24
 - LAN connectivity, 3-23
 - manageability, 3-23
 - media, 3-23
 - platforms supported, 3-22
 - protocol, 3-23
 - supported MIBs, 3-23
 - upgrade method, 3-23
- DECrepeater 90T+
 - description, 3-4

- IP service, 3-5
- LAN connectivity, 3-5
- manageability, 3-5
- media, 3-5
- platforms, 3-4
- protocol, 3-4
- supported MIBs, 3-5
- upgrade method, 3-5
- DECrepeater 90T-16
 - description, 3-6
 - IP Service, 3-7
 - LAN connectivity, 3-7
 - manageability, 3-7
 - media, 3-7
 - platform, 3-6
 - protocol, 3-6
 - supported MIBs, 3-7
 - upgrade method, 3-7
- DECrepeater 90TS
 - description, 3-8
 - IP service, 3-9
 - LAN connectivity, 3-9
 - manageability, 3-9
 - media, 3-9
 - platform, 3-8
 - protocol, 3-8
 - supported MIBs, 3-9
 - upgrade method, 3-9
- DECrepeaters
 - coaxial, 3-3
 - fiber, 3-3
 - twisted pair, 3-3
- DECserver 900GM
 - description, 3-88
 - IP service, 3-90
 - LAN connectivity, 3-89
 - media, 3-89
 - platforms supported, 3-88
 - protocol, 3-89
 - supported MIBs, 3-89
 - upgrade method, 3-89
- DECserver 900TM
 - description, 3-85
 - IP service, 3-87
 - LAN connectivity, 3-86
 - media, 3-86
 - platforms supported, 3-85
 - protocol, 3-86
 - supported MIBs, 3-86
 - upgrade method, 3-86
- DECserver 90L+
 - description, 3-79
 - IP service, 3-80
 - LAN connectivity, 3-80
 - manageability, 3-80
 - media, 3-79
 - platforms supported, 3-79
 - protocol, 3-79
 - supported MIBs, 3-80
 - upgrade method, 3-80
- DECserver 90M
 - description, 3-82
 - IP service, 3-84
 - LAN connectivity, 3-83
 - media, 3-83
 - platforms supported, 3-82
 - protocol, 3-83
 - supported MIBs, 3-83
- DECserver 90TL
 - description, 3-75
 - IP service, 3-77
 - LAN connectivity, 3-76
 - manageability, 3-76
 - media, 3-76

- platforms supported, 3-76
- protocol, 3-76
- supported MIBs, 3-77
- upgrade method, 3-76
- DECswitch 900EE
 - description, 3-49
 - IP service, 3-51
 - LAN connectivity, 3-50
 - manageability, 3-50
 - media, 3-50
 - platforms supported, 3-50
 - protocol, 3-50
 - supported MIBs, 3-51
 - upgrade method, 3-50
- DECswitch 900EF, A-9
 - description, 3-52
 - IP service, 3-55, 3-58
 - LAN connectivity, 3-54, 3-57
 - manageability, 3-54, 3-57
 - media, 3-53, 3-57
 - platforms supported, 3-53, 3-57
 - port assignments, A-9
 - protocol, 3-53, 3-57
 - supported MIBs, 3-54, 3-58
 - upgrade method, 3-54, 3-57
- DECswitch 900ET
 - description, 3-98
 - IP service, 3-99
 - LAN connectivity, 3-99
 - manageability, 3-99
 - media, 3-99
 - platforms supported, 3-98
 - protocol, 3-98
 - supported MIBs, 3-99
 - upgrade method, 3-99
- DECswitch 900FO
 - description, 3-56

- DECwanrouter 90
 - description, 3-62
 - IP service, 3-64
 - LAN connectivity, 3-63
 - manageability, 3-63
 - media, 3-63
 - platforms supported, 3-63
 - protocol, 3-63
 - supported MIBs, 3-64
 - upgrade method, 3-63
- DECwanrouter 90EW
 - description, 3-62
 - IP service, 3-64
 - LAN connectivity, 3-63
 - manageability, 3-63
 - media, 3-63
 - platforms supported, 3-63
 - protocol, 3-63
 - supported MIBs, 3-64
 - upgrade method, 3-63
- Digital MultiStack System
 - in-band management, 4-2, 4-5
- Dual
 - homing, A-41
- Dual ring
 - configurations, A-4
 - examples, A-25
 - port configuration examples, A-4
 - restriction, A-41
 - topologies, B-8
 - independent rings, B-8
 - trees topology, B-9

E

- Electronic Mail, C-1
- Email, C-1
- Enabling

ModPMD ports, A-15

Examples

dual ring configuration, A-4
environment change reaction, A-16
FDDI tree configuration, A-17
tree configuration, A-5

F

FDDI

backplane
 channels, A-3
 healing, A-31, A-33
beacon process, B-16
building blocks, A-11, B-3
chaining, A-41
claim token process, B-16
configuration
 features, A-39
 guidelines and rules, A-2
connection rules, B-12
 summary, B-15
DEChub 900 backplane, A-3
default configurations, A-14
dual
 attachment station, B-4
 homed configuration, A-5
 homing, A-22
 ring and tree, A-2
 ring configuration, A-4
 ring configuration examples, A-25
dual ring, B-1
 topologies, B-8
dual ring of trees topology, B-9
environment change, A-15
examples, A-17
fault tolerance

dual rings, A-31

trees, A-33

how rings are formed, B-13

hub backplane, A-11

individual network, A-2

MAC location, B-7

media types and maximum distances, B-5

multiple networks, A-2

naming convention, B-11

network

modules

 in a DEChub 900, A-14

 in a DEChub ONE, A-14

 in a DEChub ONE-MX, A-14

modules, change of environment, A-15

physical

 connection, B-4

 topologies, B-8

point-to-point connections, A-3

ring

 building blocks, A-11

 initialization state, B-16

 operation, B-16

single

 attachment concentrator, A-2

 attachment station, B-4

station

 configurations, B-6

 states, B-11

 types, B-3

steady state, B-17

tree

 building blocks, A-12

 configuration, A-5

 configuration examples, A-17

 topologies, B-9

- undesirable connections, B-13
- valid configurations, A-42
- Firmware
 - loading, xii
 - updates, xii
- Flash Loader, 5-14
 - features, 5-14
 - supported devices, 5-14
- FTP, xii

I

- In-band Management
 - description, 4-1
- IP Service
 - description, 4-3

M

- Management Agents
 - description, 3-91
- Management Tools, 5-1
- ManageWORKS, 5-1
- Manuals
 - reference, x
- ModPMDs
 - enabling ModPMD ports, A-15
- MultiChassis Manager, 5-8
 - features, 5-8
 - supported devices, 5-8

N

- NetView, 5-1
- Network
 - module front panel default, A-42
- Network Access Server Modules
 - half-height, 2-15
 - selecting, 2-15
- Network Access Servers

- description, 3-74
- Network Management Application Icons, 5-2
- Network Modules
 - types, 3-1

O

- Online Information, C-1

P

- PEswitch 900TX, A-10
 - description, 3-46
 - IP service, 3-48
 - LAN connectivity, 3-47
 - manageability, 3-47
 - media, 3-47
 - platforms supported, 3-47
 - port assignments, A-10
 - supported MIBs, 3-48
 - upgrade method, 3-47
- Platform types, 1-1
- Platforms, 1-1
 - selecting, 2-1
 - selection criteria, 2-1
- Point-to-point connections, A-3
- POLYCENTER, 5-1
- Port
 - assignments
 - DECconcentrator 900 TH, A-7
 - DECconcentrator 900FH, A-8
 - DECconcentrator 900MX, A-6
 - DECswitch 900EF, A-9
 - PEswitch 900TX, A-10
 - configuration in DEChub ONE-MX, A-42
- Port Switches
 - description, 3-27
- PORTswitch 900CP
 - description, 3-32

- IP services, 3-33
- LAN connectivity, 3-33
- manageability, 3-33
- media, 3-32
- platform, 3-32
- protocol, 3-32
- supported MIBs, 3-33
- upgrade method, 3-33
- PORTswitch 900FP
 - description, 3-35
 - IP service, 3-37
 - manageability, 3-36
 - media, 3-36
 - platforms supported, 3-35
 - protocol, 3-36
 - supported MIBs, 3-36
 - upgrade method, 3-36
- PORTswitch 900TP
 - description, 3-29
 - IP services, 3-30
 - LAN connectivity, 3-30
 - manageability, 3-30
 - media, 3-29
 - platforms supported, 3-29
 - protocol, 3-29
 - supported MIBs, 3-30
 - upgrade method, 3-30
- PORTswitch 90FP
 - LAN connectivity, 3-36
- PORTswitch Modules
 - full-height, 2-6
 - selecting, 2-6
- Power failure recovery, A-15
- Probes
 - description, 3-107

Q

- Quick PC Trace
 - option for concentrators, A-38

R

- Recovery Manager, 5-15
 - entire hub configuration, 5-15
 - features, 5-15
 - partial configuration, 5-16
 - supported devices, 5-16
- Remote Access Using Access Servers, 6-25
- Remote Access Using Routers, 6-25
- Repeater Modules, 2-2
 - coaxial, 2-2
 - description, 3-2
 - fiber, 2-3
 - full-height, 2-5
 - half-height, 2-2, 2-3
 - twisted pair, 2-2
- Restriction, dual ring, A-41
- Ring
 - initialization state, B-16
- RMON Manager, 5-18
 - features, 5-19
- Router Configurator, 5-4
 - features, 5-4
 - supported devices, 5-5
- Router Manager, 5-6
 - features, 5-6
 - supported devices, 5-7
- Router Modules
 - selecting, 2-14
- Routers
 - description, 3-62

S

- ServerWORKS, 5-1

- Stack Manager, 5-10
 - features, 5-10
 - supported devices, 5-10
- Stacking system, 1-7
 - features, 1-8
- Station
 - states, B-11
- Switch Modules
 - selecting, 2-9
- Switches
 - description, 3-45

T

- Token
 - flow algorithm, A-35
 - ordering of trees or dual rings, A-35
- Token Ring
 - description, 3-94
- Token Ring Modules
 - selecting, 2-17
- Tree
 - topologies, B-9
 - advantage of, B-9
 - how to identify, B-9

U

- Updating firmware, xii

V

- VLAN Manager, 5-11
 - benefits, 5-12
 - configuration flexibility, 5-12
 - features, 5-13
 - flexible access control, 5-12
 - performance, 5-12