

DECrepeater 90T-16

Installation

Part Number: EK-DETML-IN. A01

May 1995

This manual describes how to install the DECrepeater 90T-16 module.

Revision/Update Information: This is a new manual.

Copyright

May 1995

The information in this document is subject to change without notice and should not be construed as a commitment by Digital Equipment Corporation. Digital Equipment Corporation assumes no responsibility for any errors that may appear in this document.

Copyright © 1995 by Digital Equipment Corporation.
All rights reserved. Printed in U.S.A.

The postage-paid Reader's Comments form at the back of this document requests your evaluation of this document to assist us in preparing future documentation.

The following are trademarks of Digital Equipment Corporation: DEC, DEChub, DEChub ONE, DECrepeater, Digital, ThinWire, and the DIGITAL logo.

FCC NOTICE — Class A Computing Device:

This equipment generates, uses, and may emit radio frequency energy. The equipment has been type tested and found to comply with the limits for a Class A computing device pursuant to Subpart J of Part 15 of FCC Rules, which are designed to provide reasonable protection against such radio frequency interference when operated in a commercial environment. Operation of this equipment in a residential area may cause interference; in which case, measures taken to correct the interference are at the user's expense.

VCCI NOTICE — Class 1 Computing Device:

This equipment is in the 1st Class category (information equipment to be used in commercial and/or industrial areas) and conforms to the standards set by the Voluntary Control Council for Interference by Data Processing Equipment and Electronic Office Machines aimed at preventing radio interference in commercial and/or industrial areas. Consequently, when used in a residential area or in an adjacent area thereto, radio interference may be caused to radios and TV receivers.

Read the instructions for correct handling.

CE NOTICE – Class A Computing Device:

Warning!

This is a Class A product. In a domestic environment this product may cause radio interference, in which case the user may be required to take adequate measures.

Achtung!

Dieses ist ein Gerät der Funkstörgrenzwertklasse A. In Wohnbereichen können bei Betrieb dieses Gerätes Rundfunkstörungen auftreten, in welchen Fällen der Benutzer für entsprechende Gegenmaßnahmen verantwortlich ist.

Attention!

Ceci est un produit de Classe A. Dans un environnement domestique, ce produit risque de créer des interférences radioélectriques, il appartiendra alors à l'utilisateur de prendre les mesures spécifiques appropriées.

Contents

Introduction	1
Features	2
DECrepeater 90T-16 Front Panel	3
DECrepeater 90T-16 Back Panel	4
Installing the Module	5
DEChub 90/900 Installation	5
Connecting the UTP/STP Cables	7
Removing the Module from a DEChub 900/DEChub 90	8
Disconnecting the UTP/STP Port Cables	8
Removing the Module	9
LED Descriptions	10
Problem Solving Using the LEDs	11
Normal Powerup	11

Contents (Cont.)

Connector Pin Assignments	13
DECRepeater 90T-16 Front Panel (8-pin MJ) Port Connector	13
Cables	15
Product Specifications	16
Associated Documents	18

Tables

1 DECRepeater 90T-16 Module LED States	10
2 Problem Solving Using the DECRepeater 90T-16 LEDs	12
3 Front Panel (8-pin MJ) Port Connector Pin Assignments	13
4 Cables/Accessories	15
5 DECRepeater 90T-16 Operating Specifications	16
6 DECRepeater 90T-16 Acoustical Specifications	17

Introduction

The DECrepeater 90T-16 (also referred to in this manual as the module) is a 16-port 10BaseT Ethernet¹ repeater. The module provides 16 shielded 10BaseT ports using modular jack (MJ-8) connectors. The module also provides a ThinWire Ethernet interface.

You can install the DECrepeater 90T-16 in a DEChub 900 MultiSwitch (also referred to in this manual as the DEChub 900) or in a DEChub 90. You can install one or more modules (up to eight) into the DEChub 900 or the DEChub 90. When you install the module into a DEChub 900 or in a DEChub 90, the module's exchange feature (hot-swap) allows you to install or remove the module without turning off the hub's power.

When you install the DECrepeater 90T-16 in a DEChub 900 or DEChub 90, the module's backplane connector makes connection with the hub, which supplies power and a ThinWire channel. The DECrepeater 90T-16 may also be used in a non-modular (stackable) configuration using the optional stackable docking station.

The module's 16 10BaseT ports on the front panel support 100-ohm unshielded twisted pair (UTP) and 100-ohm shielded twisted-pair (STP) cables. The module's front panel also contains light-emitting diodes (LEDs) that indicate the status of the 10BaseT ports, network traffic, ThinWire interface, and power.

¹ The term Ethernet is used by Digital Equipment Corporation to refer to its product compatibility with the ISO 8802-3/ANSI/IEEE 802.3 standards and the Ethernet standards for Carrier Sense Multiple Access with Collision Detection (CSMA/CD) local area networks (LANs).

Introduction (Cont.)





Features

The DECrepeater 90T-16 provides the following features:

- Stackable or DEChub operation.
- Automatic module self-test at power-up.
- Hot-swappable when used in DEChub 900 or DEChub 90.
- Management supporting the IETF Repeater MIB (RFC 1516) and the Digital Equipment Corporation internal extended repeater MIB (requires use of management agent*).
- User-friendly advanced graphical user interface (GUI) manageability with HUBwatch Network Management Station (NMS) application when using an SNMP busmaster management agent.*

* The DECrepeater 90TS V2.0 and DECrepeater 90FS V2.0 (available August, 1995), DECAgent 90 V3.0, or the DEChub 900 MultiSwitch may be used as the management agent.

DECrepeater 90T-16 Front Panel

- 1) **Power**  **LED** — Lights when the module has power.
 - 2) **ThinWire Status**  **LED** — Shows the status of the ThinWire interface.
 - 3) **Module**  **OK LED** — Indicates successful completion of power-up self-test.
 - 4) **Network Activity**  **LED** — Indicates network traffic level. More traffic causes the LED to glow brighter.
 - 5) **Port State LEDs (1 through 16)** — Shows the status of each of the 16 ports. The port LED lights when the port is enabled, is not partitioned, and its media are available. The port LED is off when the port is enabled but is either partitioned or its media are unavailable. The port LED flashes if the port is disabled.
- NOTE:** For more information about LED operation, refer to the section titled LED Descriptions.
- 6) **10Base-T (8-pin MJ) port connectors (1 through 16)** — Connectors for ports 1 to 16.
 - 7) **ThinWire port connector** — Used to make a backbone connection to the repeater (stackable use only).

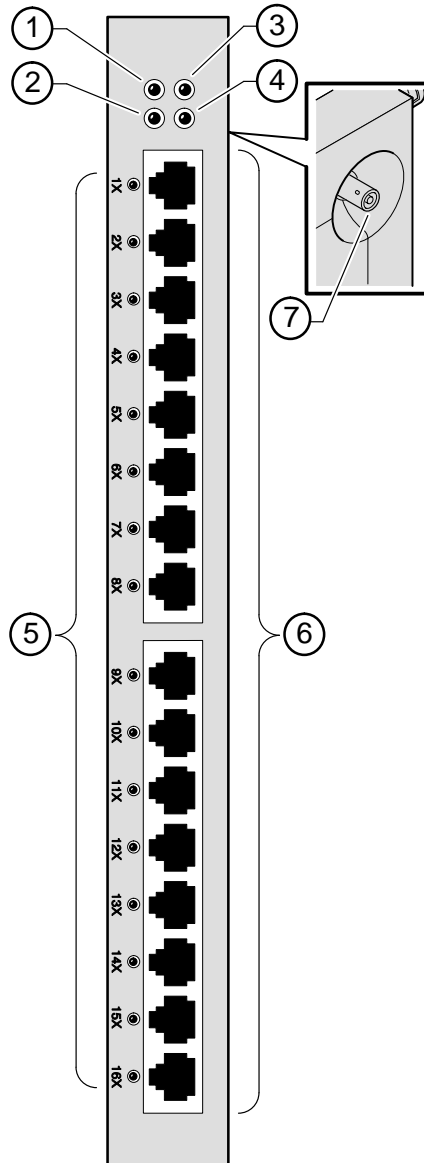

MPG-0032-95I

DECrepeater 90T-16 Back Panel

- 1) **Mounting tab** — Secures the module to the backplane when the module is installed into a DEChub 900 or a DEChub 90.
- 2) **48-pin connector** — Provides management, network, and power connections to the module.
- 3) **Grounding bolt** — Provides a chassis grounding connection to the module.
- 4) **Mounting foot** — Facilitates rocking of module into the DEChub 90 or the DEChub 900.

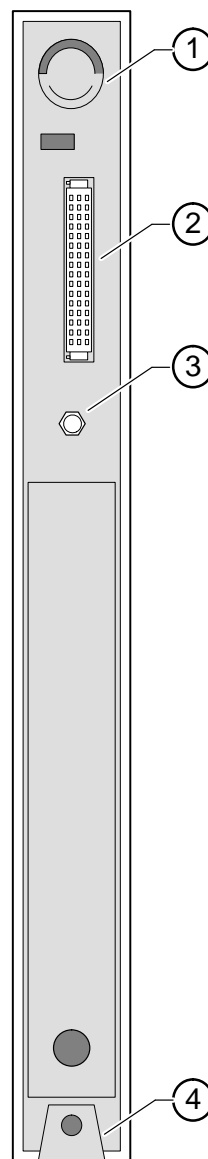

NPG-0022-95I

Installing the Module

You can install the DECrepeater 90T-16 into a DEChub 90 or a DEChub 900.

DEChub 90/900 Installation

The DECrepeater 90T-16 hot-swap feature allows you to install the repeater module into the DEChub 90 or DEChub 900 without turning off the hub's power. Seating the module initiates the power-up sequence.

Installing the Module (Cont.)

- 1 Seat the repeater module into the DEChub 90/DEChub 900.
 - a. Place the module's mounting foot into a mounting slot on the DEChub 90/DEChub 900 (1).
 - b. Pull up on the release lever to its unlocked position (2).
 - c. Pivot the module on the mounting foot and align the connectors.
 - d. Firmly push the module onto the backplane connector.
 - e. Press down on the release lever to ensure that it is locked (3).
- 2 Verify that the repeater module's Power  LED lights immediately and remains lit.

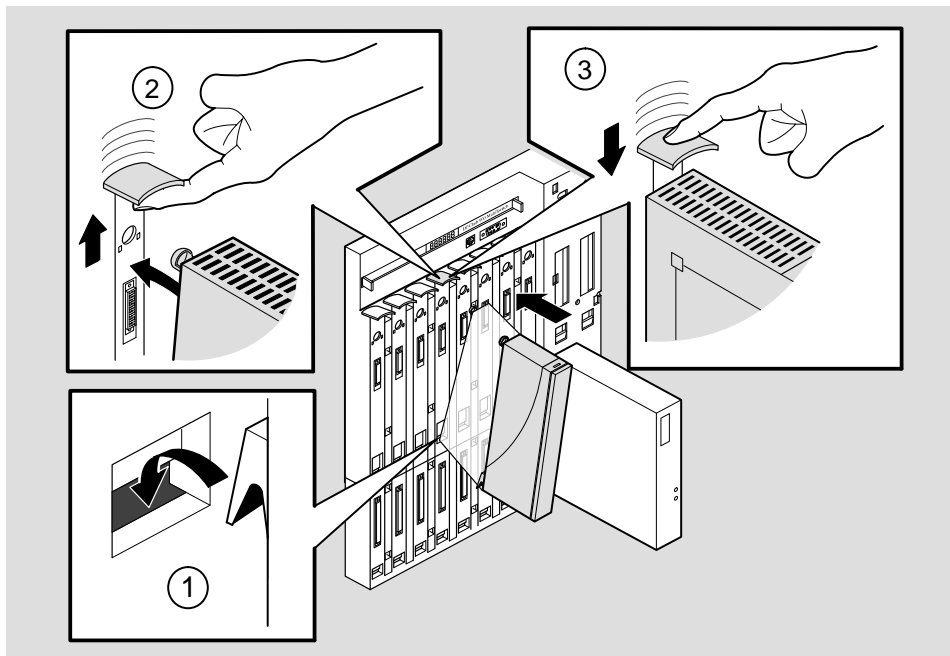

NPG-0164-95I

Installing the Module (Cont.)

Connecting the UTP/STP Cables

The DECrepeater 90T-16's 10BaseT ports are connected using 8-pin MJ connectors. Before connecting the cables to the module, be sure to select the appropriate straight-through cables. You must use the appropriate UTP/STP straight-through cable type to ensure that the module's transmit/receive signals connect correctly to the transmitter/receiver of the connected device. If you need help determining the cable to use, refer to the section titled Connector Pin Assignments.

NOTE: Digital's straight-through cables are marked (=).

- 1 Align the release tab on the cable plug with the keyway on the module's 10BaseT (8-pin MJ) port connector. Insert the plug into the connector, ensuring that the release tab snaps into the locked position.

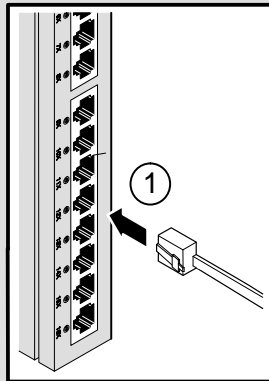

NPG-0109-951

Removing the Module from a DEChub 900/DEChub90

Disconnecting the UTP/STP Port Cables

- 1 Press the release tab on the 8-pin MJ connector. Disconnect the cable.

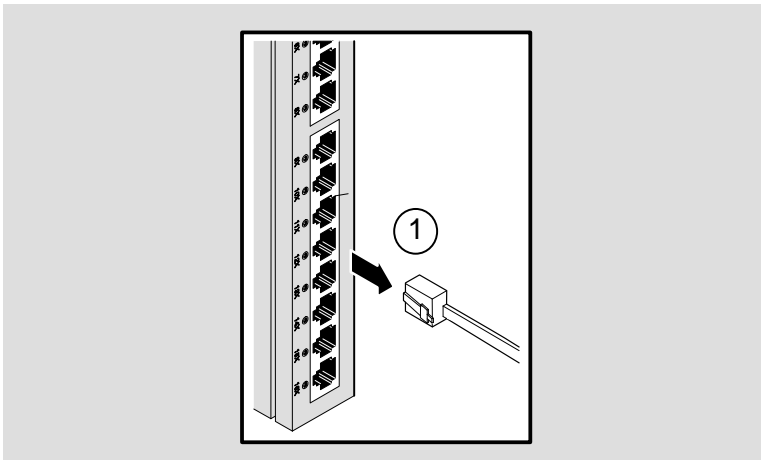

NPG-0109-95I

Removing the Module from a DEChub 900/DEChub90

Removing the Module

- 1 Lift the release lever located on the top of the DEChub 900 module slot or the DEChub 90 module slot **(1)**.
- 2 Disengage the module from the backplane **(2)**.
- 3 Pivot the module back on its bottom mounting tab and remove **(3)**.

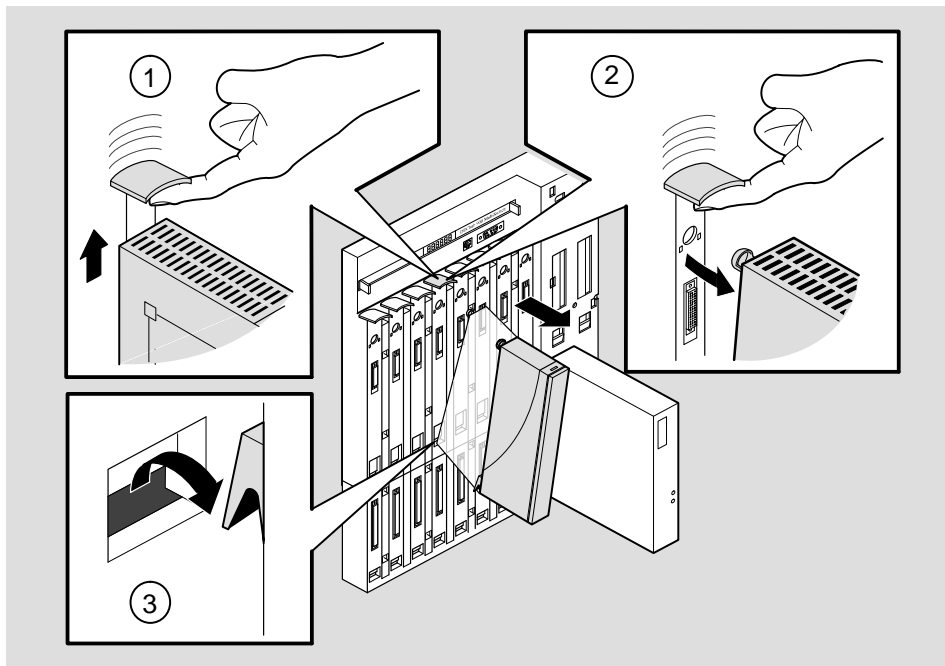





NPG-0163-95I

LED Descriptions

The module LEDs provide dynamic indications of module status. Flashing LEDs indicate special situations.

Table 1 shows the static states that are possible for each of the module LEDs.

Table 1 DECrepeater 90T-16 Module LED States



LED Name	Icon	Off	On	Flashing
Power		The module is not receiving power.	The module is receiving power.	N/A.
ThinWire Status		The ThinWire 10Base 2 port is not connected to a properly terminated and operational LAN.	The ThinWire 10Base 2 port is connected to a properly terminated and operational LAN.	The ThinWire 10Base2 port is disabled by network management.
Module OK		After 10 seconds, the self-test failed.	The module passed the self-test.	N/A.
Network Activity		No network activity exists.	Traffic exists on the ThinWire network. This LED appears brighter as network traffic increases.	N/A.
Port State	1 through 16	Port is enabled but is partitioned or its media are unavailable.	Port is enabled, not partitioned, and its media are available.	The associated port is disabled by network management.

Problem Solving Using the LEDs

When diagnosing a problem with the module, note that the problem is often indicated by the states of the module LEDs. Table 2 lists the states of the LEDs for various error conditions that can occur during initial installation of the device on the DEChub 900 or DEChub 90, along with probable causes and corrective actions to take.



Normal Powerup

When power to the module is initially turned on, the following events occur:

1. The Power  LED lights and stays lit.
2. The module initiates its built-in self-test. During self-test, the Port State LEDs cycle through various patterns.
3. After the successful completion of self-test (within ten seconds), the Module OK  LED lights, and remains lit.
4. The remaining LEDs indicate their operational status, as described in Table 1.

Problem Solving Using the LEDs (Cont.)

Table 2 Problem Solving Using the DECRepeater 90T-16 LEDs

Symptom	Probable Cause	Corrective Action
Power  LED is off.	The module does not have power.	Verify the hub's power. Reseat the module.
	Power not reaching module.	Remove the module and inspect the module's 48-pin connector for bent, broken, or dirty pins. If no pins are broken or bent, reinstall the module. If the problem persists, replace module. If problem persists, replace power supply.
Module OK  LED is off.	Self-test is in progress.	Wait for self-test to complete.
	Self-test failed.	If the LED does not light after 10 seconds, reseat the module to repeat the self-test. If self-test fails again, replace the module.
Port State LED is off.	Improper cable connection.	Check that the cables are installed properly.
Port State LED is flashing.	Associated port is disabled by network management.	Enable the associated port, if necessary.

Connector Pin Assignments

DECrepeater 90T-16 Front Panel (8-pin MJ) Port Connector

The following illustration shows the front-panel 8-pin MJ connector. Table 3 describes the pin assignments.

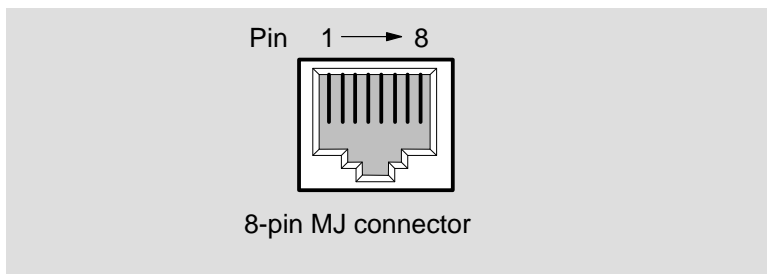

NPG-0162-95I

Table 3 Front -Panel (8-pin MJ) Port Connector Pin Assignments

Pin	Assignment	Pin	Assignment
1	RX+	5	Unused
2	RX-	6	TX-
3	TX+	7	Unused
4	Unused	8	Unused

The Crossover Function

A crossover function must be implemented in every twisted-pair link. The crossover function (internal or external) allows the transmitter of one device to connect to the receiver of the device at the other end of the twisted-pair link.

Connector Pin Assignments (Cont.)

The DECrepeater 90T-16 provides a signal-line crossover connector for each port. This enables the ports to use the more common straight-through cables. When connecting the DECrepeater 90T-16 to a MAU, you must use a straight-through cable. The following two figures show the use of straight-through and crossover cables for connecting internal and external crossover-type devices.

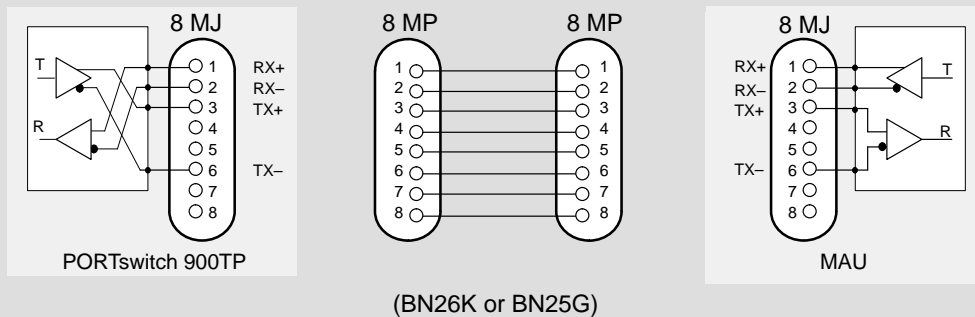

NPG-0103-951

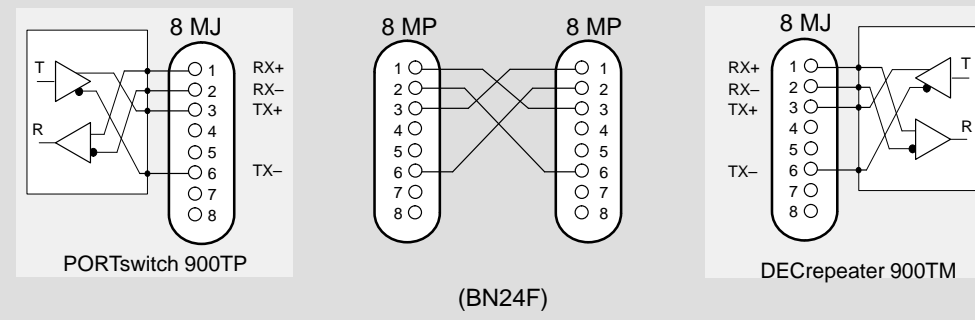

NPG-0104-951

Cables

Table 4 describes the cables and accessories that are available for connecting the devices. Contact your Digital sales representative for additional information.

Table 4 Cables and Accessories

Cable/Accessory and Description	Order Number
Crossover UTP	BN26S
Straight-through TP	BN25G
T-connector	H8223
50 ohm Terminator	H8225

Product Specifications

Table 5 lists the DECrepeater 90T-16 physical, environmental, and certification specifications.

Table 5 DECrepeater 90T-16 Operating Specifications

Parameter	Specification
<i>Operating Environment</i>	
Operating temperature ¹	5° C to 50° C (41° F to 122° F)
Relative humidity	10% to 95% noncondensing
Altitude ¹	Sea level to 4900 m (16,000 ft)
Power	6.0 W, total power 1.2 A, 5Vdc, 0.0 A, 12Vdc 0.0 A, 15Vdc
<i>Physical</i>	
Height	27.3 cm (10.75 in)
Width	3.2 cm (1.25 in)
Depth	11.2 cm (4.4 in)
Weight	0.91 kg (2.0lb)

¹ For sites above 4900 m (16,000 ft), decrease the operating temperature specification by 1.8° C for each 1000 m or 3.2°F for each 3200 ft.

Product Specifications (Cont.)

Table 6 lists the acoustical specifications for the DECrepeater 90T-16.

Table 6 DECrepeater 90T-16 Acoustical Specifications

Acoustics — Declared values per ISO 9296 and ISO 7779¹

Product	Sound Power Level $L_{WA,d}$, B	Sound Pressure Level L_{pAm}, dBA (bystander positions)
	<i>Idle/Operate</i>	<i>Idle/Operate</i>
DETML	No acoustic noise	No acoustic noise
DETML – Stackable	No acoustic noise	No acoustic noise

Schallemissionswerte — Werteangaben nach ISO 9296 und ISO 7779/DIN EN27779²

Produkt	Schalleistungspegel $L_{WA,d}$, B	Schalldruckpegel L_{pAm}, dBA (Zuschauerpositionen)
	<i>Leerlauf/Betrieb</i>	<i>Leerlauf/Betrieb</i>
DETML	keine meßbaren Schallemissionen	keine meßbaren Schallemissionen
DETML – Stackable	keine meßbaren Schallemissionen	keine meßbaren Schallemissionen

¹ Current values for specific configurations are available from Digital Equipment Corporation representatives. 1 B = 10 dBA.

² Aktuelle Werte für spezielle Ausrüstungsstufen sind über die Digital Equipment Vertretungen erhältlich. 1 B = 10 dBA.

Associated Documents

The following documents provide related information about the module. Ordering information is provided at the back of this manual.

Title and Order Number	Description
<i>DEChub 900 MultiSwitch Owner's Manual</i> EK-DH2MS-OM	Provides installation, use, security, and troubleshooting information.
<i>HUBwatch Installation and Configuration</i> AA-Q3S8D-TE	Provides information for installing and configuring HUBwatch for Windows V2.0.
<i>HUBwatch Use</i> AA-PW4BE-TE	Provides network management and DEChub 900, DEChub 90 and DEChub ONE functionality information for HUBwatch for Open VMS V3.0.
<i>DEChub 90 Owner's Manual</i> EK-DEHUB-OM	Provides installation, use, security, and troubleshooting information.
<i>OPEN DECconnect Structured Wiring System Applications Guide</i> EC-G2570-42	Contains general descriptions to help plan and install networking systems based on the OPEN DECconnect system and networking products from Digital Equipment Corporation.

HOW TO ORDER ADDITIONAL DOCUMENTATION

DIRECT TELEPHONE ORDERS

In Continental USA
call 1-800-DIGITAL
(1-800-344-4825)

In Canada
call 1-800-267-6215

In New Hampshire,
Alaska or Hawaii
call 1-603-884-6660

ELECTRONIC ORDERS (U.S. ONLY)

Dial 1-800-dec-demo with any VT100 or VT200 compatible terminal and a 1200 baud modem.
If you need assistance, call 1-800-DIGITAL (1-800-344-4825)

DIRECT MAIL ORDERS (U.S. and Puerto Rico*)

DIGITAL EQUIPMENT CORPORATION
P.O. Box CS2008
Nashua, New Hampshire 03061

DIRECT MAIL ORDERS (Canada)

DIGITAL EQUIPMENT OF CANADA LTD.
940 Belfast Road
Ottawa, Ontario, Canada K1G 4C2
Attn: A&SG Business Manager

INTERNATIONAL

DIGITAL EQUIPMENT CORPORATION
A&SG Business Manager
c/o Digital's local subsidiary
or approved distributor

Internal orders should be placed through U.S. Software Supply Business (SSB),
Digital Equipment Corporation, 10 Cotton Rd. Nashua, NH. 03063-1260

*Any prepaid order from Puerto Rico must be placed
with the Local Digital Subsidiary:
809-754-7575

**DECrepeater 90T-16 Installation
EK-DETML-IN. A01**

Please return this card.

Your comments and suggestions will help us improve the quality and usefulness of our documentation.

Did you use the manual as a reference or as a step-by-step procedure to install the device?

Were the instructions easy to follow? _____

Were the instructions complete? _____

Were they in the proper sequence? _____

Which chapters or sections were most helpful? _____

Did you use the appendixes? Which ones? _____

Were the illustrations helpful? _____ All? _____ Some? _____ Which ones? _____

Were some illustrations unnecessary? _____ Which ones? _____

Do you think the manual needs more illustrations? _____ Please give an example. _____

Thank you.

Name _____ Date _____

Title _____ Department _____

Organization _____ Street _____

City _____ State/Country _____ Zip Code _____

DO NOT CUT - FOLD HERE AND TAPE

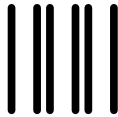

NO POSTAGE
NECESSARY
IF MAILED
IN THE
UNITED STATES

BUSINESS REPLY LABEL

FIRST CLASS PERMIT NO. 33 MAYNARD MASS.

POSTAGE WILL BE PAID BY ADDRESSEE



SES
550 King Street, LKG1-3/L12
Littleton, MA 01460-1289

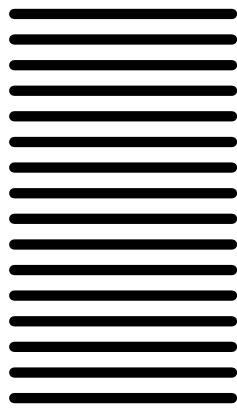

DO NOT CUT - FOLD HERE