

digital

Service Maintenance Manual

VENTURIS Pentium PC

K-MN-SD00000-06-JG00.B



MCS LOGISTICS
ENGINEERING
-
NIJMEGEN
THE NETHERLANDS

Copyright Digital Equipment Corporation
All rights reserved
February 1996

February 1996

The information in this document is subject to change without notice and should not be construed as a commitment by Digital Equipment Corporation.

Digital Equipment Corporation assumes no responsibility for any errors that might appear in this document. The software, if any, described in this document is furnished under a license and may be used or copied only in accordance with the terms of such license. No responsibility is assumed for the use or reliability of software or equipment that is not supplied by Digital Equipment Corporation or its affiliated companies.

Restricted Rights: Use, duplication, or disclosure by the U.S. Government is subject to restrictions as set forth in subparagraph (c) (1) (ii) of the Rights in Technical Data and Computer Software clause at DFARS 252.227-7013.

Copyright Digital Equipment Corporation

All Rights Reserved

The following are trademarks of Digital Equipment Corporation:
VENTURIS and the Digital logo.

The following are third party trademarks:

MS-DOS and Windows and Windows NT and Windows NT Server are trademarks of Microsoft Corp.

Novell and Netware are trademarks of Novell, Inc.

SCO and Open Desktop are trademarks of The Santa Cruz Operation, Inc.

UNIX is a registered trademark of UNIX System Laboratories, Inc.

All other trademarks and registered trademarks are the property of their respective holders.

Created by:

MCS Logistics Engineering - Nijmegen

Printed in Ireland

Table of Contents

REVISION HISTORY	7
PREFACE.....	9
CHAPTER 1 PRODUCT DESCRIPTION	11
PRODUCT INTRODUCTION	11
PRODUCT MODELS INFORMATION	12
VENTURIS 560 Models	12
VENTURIS 575, FP575 and faster models	12
VENTURIS 575 E Models.....	13
CHAPTER 2 SYSTEM UTILITIES & CONFIGURATION.....	15
SYSTEM UTILITIES	15
Before Using System Utilities and Video Drivers.....	15
PHLASH.EXE.....	16
Creating a Crisis Recovery Diskette.....	16
Using the Crisis Recovery Diskette	17
Upgrading the Computer BIOS.....	17
EPP3SMC.EXE.....	18
VIDEO DRIVERS & UTILITIES.....	18
Setting High Resolution Mode for the Monitor Display.....	18
SMODE.EXE	18
SMTR.EXE.....	19
DOS Video Drivers.....	20
Windows 3.x Drivers	20
BIOS SETUP UTILITY	20
Running the BIOS Setup Utility	21
Helpful Hints	21
BIOS SETUP UTILITY OPTIONS	22
Main Menu Options	22
Boot Options.....	22
Fixed Disk Setup OptionsIDE Adapter 0/1 Master/Slave.....	23
Keyboard Features.....	24
Memory and Cache Options.....	24
Advanced Chipset Control	25
Integrated Peripherals	26
Large Disk Access Mode.....	27
Power Options	28
Security Options.....	29

CHAPTER 3 SERVICE PROCEDURES.....	31
SAFETY REQUIREMENTS	31
RECOMMENDED TOOLS	32
Other Materials Needed.....	Error! Bookmark not defined.
Special Tools Required.....	32
Remedial Diagnostic Test Software	32
Recommended Virus Detection and Cleanup Software.....	33
ECO/FCO INFORMATION	33
BIOS Version Information	33
UNLOCKING AND REMOVING COVER	34
COMPUTER COMPONENTS	35
VENTURIS Pentium Slimline Models.....	35
VENTURIS Pentium Full Profile Models.....	36
EXPANSION SLOTS	37
VENTURIS Pentium Slimline Models Expansion Slots	37
VENTURIS Pentium Full Profile Models Expansion Slots	38
MAIN LOGIC BOARD JUMPERS	39
VENTURIS 560 Models Main Logic Board Jumper Settings.....	39
VENTURIS 560 Models Main Logic Board Jumper Locations.....	39
VENTURIS Pentium version 1.0 Main Logic Board Jumper Settings.....	40
VENTURIS Pentium version 1.0 Main Logic Board Jumper Locations.....	41
VENTURIS Pentium version 2.0 Main Logic Board Jumper Settings.....	42
VENTURIS Pentium version 2.0 Main Logic Board Jumper Locations.....	43
COMPUTER MEMORY CONFIGURATIONS	44
VENTURIS 560 Memory Configurations	44
VENTURIS 560 SIMM Sockets Locations	44
VENTURIS Pentium version 1.0 board Memory Configurations	45
VENTURIS Pentium version 1.0 board SIMM Sockets Locations	45
VENTURIS Pentium version 2.0 board Memory Configurations	46
VENTURIS Pentium version 2.0 board SIMM Sockets Locations	47
VENTURIS 575 E board Memory Configurations	47
PART REMOVAL AND REPLACEMENT	48
Opening the VENTURIS Slimline Device Bay & Power Supply Subassembly.....	48
Opening the VENTURIS Full-Profile Device Bay & Power Supply Subassembly	49
Removing the 3½-Inch Diskette Drive (All Models)	50
Removing the VENTURIS Pentium Main Logic Board.....	51
Removing the VENTURIS Power Supply	52
INSTALLATION PROCEDURES	53
Installing a Higher Performance CPU.....	53
Installing Video Memory	54
REPLACEMENT PROCEDURES	55
Replacing the Real-Time Clock (RTC)/Lithium Battery	55
CONNECTING DISKETTE AND IDE DEVICES	57
Diskette Data Cable Connections	58
IDE Data Cable Connections	59

CHAPTER 4 TROUBLESHOOTING	61
INITIAL TROUBLESHOOTING	61
BEEP CODES	62
POST AND BOOT MESSAGES	62
COMPUTER TROUBLESHOOTING	64
DISK DRIVE TROUBLESHOOTING	68
MONITOR TROUBLESHOOTING	68
QAPlus/FE Error Messages.....	69
CHAPTER 5 DEVICE MAPPING	71
CPU Memory Address Map (Full Range).....	71
I/O Address Map.....	72
Computer Interrupt Levels	73
DMA Channel Assignment	73
CHAPTER 6 PASS / FAIL CRITERIA	75
APPENDIX A SERVICE NOTES	77
APPENDIX B USEFUL INFORMATION	79
RELATED DOCUMENTATION	79
ON-LINE BULLETIN BOARDS	79
DOCUMENT FEEDBACK	81
PERSONAL NOTES	83
READERS COMMENTS.....	87

Table of Figures

Figure 3 - 1 Unlocking the Cover	34
Figure 3 - 2 Releasing the Cover.....	34
Figure 3 - 3 Removing the Cover.....	34
Figure 3 - 4 VENTURIS Pentium Slimline models.....	35
Figure 3 - 5 VENTURIS Pentium Full Profile Models	36
Figure 3 - 6 VENTURIS Pentium Slimline Expansion Slots.....	37
Figure 3 - 7 VENTURIS Pentium Full Profile Expansion Slots.....	38
Figure 3 - 8 VENTURIS 560 Main Logic Board Jumpers Locations	39
Figure 3 - 9 VENTURIS Pentium version 1.0 Main Logic Board Jumper Locations.....	41
Figure 3 - 10 VENTURIS Pentium version 2.0 Main Logic Board Jumper Locations	43
Figure 3 - 11 VENTURIS 560 SIMM Sockets Locations.....	44
Figure 3 - 12 VENTURIS Pentium version 1.0 board SIMM Sockets Locations.....	45
Figure 3 - 13 VENTURIS Pentium version 2.0 board SIMM Socket Locations	47
Figure 3 - 14 Release front locking mechanism	48
Figure 3 - 15 Lock in place.....	48
Figure 3 - 16 Opening the VENTURIS Full-Profile Device Bay & Power Supply Subassembly.....	49
Figure 3 - 17 Removing the 3½-inch diskette drive on the VENTURIS Slim Line models.....	50
Figure 3 - 18 Removing the 3½-inch diskette drive on the VENTURIS Full-Profile models.....	50
Figure 3 - 19 Removing the VENTURIS Pentium Main Logic Board	51
Figure 3 - 20 Removing the Power Supply on the VENTURIS Slimline models.....	52
Figure 3 - 21 Removing the Power Supply on the VENTURIS Full-Profile Power Supply	52
Figure 3 - 22 Installing a Higher Performance CPU	53
Figure 3 - 23 Installing Video Memory	54
Figure 3 - 24 Replacing the Real-Time Clock	55
Figure 3 - 25 Replacing the Lithium Battery.....	56
Figure 3 - 26 Diskette Drive Data Cable Connections	58
Figure 3 - 27 IDE Data Cable Connections.....	59

Revision History

Revision 0.0	This was the original release of the Service Maintenance Manual describing the VENTURIS 486 and VENTURIS Pentium series computer in its original configuration.
Revision A01	The original Service Maintenance Manual has been split into two Service Maintenance Manuals; for the VENTURIS 486 PC family (EK-A0813-SV.A01) and for the VENTURIS Pentium PC family (EK-A0814-SV.A01).
Revision B01	This revision of the VENTURIS 486 PC Service Maintenance Manual incorporates updated configurations and various models that have been added.

Preface

The Digital VENTURIS Pentium Service Maintenance Manual is a troubleshooting guide that can be used for reference when servicing the VENTURIS Pentium line of PC's.

Digital Equipment Corporation reserves the right to make changes to the Digital VENTURIS Pentium series without notice. Accordingly, the diagrams and procedures in this document may not apply to the computer(s) to be serviced since many of the diagnostic tests are designed to test more than one product.



CAUTION

Digital recommends that only A+ certified engineers attempt to repair this equipment. All troubleshooting and repair procedures are detailed to support subassembly/module level exchange. Because of the complexity of the individual boards and subassemblies, no one should attempt to make repairs at component level or to make modifications to any printed wiring board. Improper repairs can create a safety hazard. Any indications of component replacement or printed wiring board modifications may void warranty or exchange allowances.

Chapter 1

Product Description

Product Introduction

The VENTURIS Pentium computers are high-performance personal computers featuring the latest in computing technology. They can be used as stand-alone computers, as clients, or as servers in a network environment. Developed using the following state-of-the-art technology, these computers are the most value packed Slimline and Full-Profile desktop computers in their class.

- ◆ **Microprocessor**
Pentium CPU at 60 MHz, 75 MHz, 90 MHz, 100 MHz, 120 MHz and 133 MHz.
- ◆ **Plug and Play**
Optional Plug and Play compatible expansion boards are automatically configured under Windows 95 for easy installation.
If using DOS/Windows, optional Plug and Play compatible expansion boards are automatically configured using the ISA Configuration Utility (ICU) for easy installation.
- ◆ **Advanced Power Management**
Reduces the computer's energy consumption and operating costs.
- ◆ **Onboard Video**
S3 Trio 32 or 64 btechnology to take full advantage of the computer's CPU and power management features. Video controller circuitry is incorporated into the main logic board; a separate video adapter is unnecessary.
- ◆ **Onboard Cache (Not on Venturis E models)**
256 KB secondary cache provides faster access to current files than system RAM.

Product Models Information

EC = English, French, German, Italian and Spanish.

ED = Danish, Dutch, English, Finnish, French (France excluded), Norwegian and Swedish.

VENTURIS 560 Models

<i>Product</i>	<i>Model</i>	<i>FDD</i>	<i>HDD</i>	<i>Memory</i>	<i>Cache</i>	<i>Options</i>
VENTURIS 560	FR-856EC-AD	1.44MB	None	4MB	None	
	FR-856E*-WB	1.44MB	270MB	4MB	256KB	

VENTURIS 575, FP575 and faster models

<i>Product</i>	<i>Model</i>	<i>FDD</i>	<i>HDD</i>	<i>Memory</i>	<i>Cache</i>	<i>Options</i>
VENTURIS 575	FR-920**-WB	1.44MB	420MB	8MB	256KB	
	FR-920**-WD	1.44MB	840MB	8MB	256KB	
	FR-920**-WE	1.44MB	1.2GB	8MB	256KB	
	FR-920**-WG	1.44MB	420MB	8MB	256KB	Quad-speed CD-ROM
	FR-920WW-CB	1.44MB	420MB	8MB	256KB	
	FR-920WW-CC	1.44MB	630MB	8MB	256KB	
	FR-920WW-CD	1.44MB	840MB	8MB	256KB	
	FR-920WW-CE	1.44MB	1.2GB	8MB	256KB	
	FR-920WW-CG	1.44MB	420MB	8MB	256KB	Quad-speed CD-ROM
	FR-920WW-CH	1.44MB	630MB	8MB	256KB	Quad-speed CD-ROM
	FR-920WW-CI	1.44MB	630MB	8MB	256KB	Quad-speed CD-ROM
VENTURIS FP 575	FR-921**_**					
VENTURIS 590	FR-922**_**					
VENTURIS FP 590	FR-923**_**					
VENTURIS 5100	FR-924**_**					
VENTURIS FP 5100	FR-925**_**					
VENTURIS 5120	FR-926**_**					

VENTURIS 575, FP575 and faster models (continued)

<i>Product</i>	<i>Model</i>	<i>FDD</i>	<i>HDD</i>	<i>Memory</i>	<i>Cache</i>	<i>Options</i>
VENTURIS FP 5120	FR-927**_**					
VENTURIS 5133	FR-928**_**					
VENTURIS FP 5133	FR-929**_**					
VENTURIS 5150	FR-92D**_**					
VENTURIS FP 5150	FR-92E**_**					
VENTURIS 5166	FR-92F**_**					
VENTURIS FP 5166	FR-92G**_**					

VENTURIS 575 E

<i>Product</i>	<i>Model</i>	<i>FDD</i>	<i>HDD</i>	<i>Memory</i>	<i>Cache</i>	<i>Options</i>
VENTURIS E 575	FR-92BWW- CC	1.44MB	630MB	8MB	None	EDO-RAM
VENTURIS E 575	FR-92BWW- CD	1.44MB	1.2GB	8MB	None	EDO-RAM

Chapter 2**System Utilities &**

Chapter 2

System Utilities & Configuration

System Utilities

This chapter describes how to use the utilities and video drivers supplied with the VENTURIS Pentium computer. In most cases, these utilities and drivers have been factory installed as image files on the hard disk drive. However, before attempting to use any of the utilities or install any of the video drivers, first copy all image files onto diskettes using the Create Installation Diskettes tool in *Getting Started*. Afterwards, use these diskettes to run any of the utility programs and/or to install drivers.

When utilities and video driver diskettes have been purchased, refer to the supplied MS-DOS/Windows documentation for information on creating back-up diskettes.

System utilities consisting of:

- ◆ PHLASH.EXE – enables to upgrade or restore the computer's BIOS via Flash ROM.
- ◆ EPP3SMC.EXE – enables to configure the computer for EPP operation.
- ◆ Logitech mouse drivers – enables the computer to operate using a Logitech mouse.
- ◆ VGA utilities and DOS video drivers consisting of:
 - ◇ SMTR.EXE – enables to select the monitor type that matches the monitor's available resolution and refresh rates.
 - ◇ SMODE.EXE – enables to emulate or display non-standard VGA modes.
 - ◇ DOS and CAD application video drivers– provides installation instructions and, where applicable, the usage and performance tips for several S3 Trio 32/64 bit video drivers.
 - ◇ README.TXT - contains information on the display drivers and instructions for configuring the computer to operate with a high resolution monitor. Additional product information not available at the time of manual, printing might also be available.
 - ◇ Windows 3.x video drivers:
These files consist of S3 Trio 32/64 bit video drivers.

Before Using System Utilities and Video Drivers

When unfamiliar with utility programs and video drivers and their uses, carefully read and understand this chapter before attempting to use any of the utilities or installing video drivers.

PHLASH.EXE

All VENTURIS Pentium computers have BIOS software in a read-only, non-volatile memory (ROM) chip. The BIOS initializes hardware and boots the operating system when the computer is switched on. The BIOS also provides access to other devices such as keyboard and disk drives.

The computer comes equipped with flash memory. This means that the computer's BIOS can be restored simply by running the PHLASH.EXE utility contained on the supplied System Utilities diskette. The computer's BIOS can also be upgraded to future releases by running PHLASH.EXE along with any flash BIOS update diskette, if necessary.



CAUTION

When not familiar with utility programs and their uses, carefully read and understand all of the listed topics before attempting to use PHLASH.EXE.

Have the following items available:

- ◆ Blank 3½-inch 1.44 MB formatted diskette
- ◆ Diskette copy of the system utilities

Creating a Crisis Recovery Diskette

A crisis recovery diskette should always be prepared before attempting to upgrade the BIOS. This diskette is used to reprogram the BIOS in case the flash process fails. To create a crisis recovery diskette:

- 1) Turn on the computer and allow the POST to complete. If POST detects an error refer to "*Troubleshooting*" and take the appropriate steps to correct the problem. After the problem has been resolved, restart the computer.
- 2) Insert the system utilities diskette you created from Getting Started and make sure the following files are in the UPGRADE directory:

MINIDOS.SYS
PHLASH.EXE
DEVTBLS.DAT
PHLASH.INI
VENTURIS.ROM
MAKEBOOT.EXE
MAKECRD.EXE

NOTE This diskette also contains multilingual BIOS files that can be used to change the language type in Setup.

- 3) Create the same directory on the hard disk drive and then copy the above files to it.
- 4) Insert a blank formatted diskette into drive A.
- 5) On drive A, make a directory for the files previously copied.
- 6) From drive C: type **MAKECRD**. This copies the files to drive A.
- 7) Remove the crisis recovery diskette from drive A and store it in a safe place.

Using the Crisis Recovery Diskette

The crisis recovery diskette must be used only if the computer's BIOS fails or if a BIOS upgrade was unsuccessful.

- ◆ POST detects an error after a normal boot cycle or a BIOS upgrade.
- ◆ The BIOS in the bootblock memory executes.
- ◆ The computer beeps several times.
- ◆ The diskette drive begins searching for the crisis recovery diskette.

If the computer's BIOS fails:

- 1) Set the recovery jumper (**J25 on VENTURIS 560 models, J10 on the other VENTURIS Pentium models**) to *enabled*.
- 2) Insert the crisis recovery diskette into drive A and power on the computer.
- 3) After the BIOS is restarted, turn off the power and remove the crisis recovery diskette from drive A.
- 4) Turn the power back on for normal operation.

Upgrading the Computer BIOS

NOTE If this is the first time using these utility programs and/or video drivers it is recommended to follow the procedures in the order given.

The following utilities and video drivers enable to upgrade or restore the computer's BIOS and take full advantage of its enhanced video features:

- 1) Turn on or reboot the computer. If POST detects an error, refer to "*Troubleshooting*" for possible causes and suggested solutions.
- 2) If necessary, run PHLASH.EXE to upgrade or restore the computer's BIOS.
- 3) Run EPP3SMC.EXE to configure the computer for EPP operation.
- 4) Run SMTR.EXE to select the monitor type that matches the monitor's available resolution and refresh rates.
- 5) If necessary, run SMODE.EXE to emulate or display a non-standard VGA mode.
- 6) Install any applicable DOS or CAD application drivers.
- 7) Install any Windows 3.x video drivers.

Perform the following steps to update the computer's BIOS in the flash memory:

- 1) Turn on the computer and allow the POST to complete. If POST detects an error refer to "*Troubleshooting*" and take the appropriate steps to correct the problem. After the problem has been resolved, restart the computer.
- 2) Create a crisis recovery diskette if not already done so. Refer to "*Creating a Crisis Recovery Diskette*".
- 3) Insert the system utilities diskette.
- 4) At the MS-DOS prompt, enter the following commands (press [Enter] after each command):

```
a:
cd\UPGRADE
PHLASH /e
```

A screen appears on the monitor warning that you are about to erase the computer's BIOS.

- 5) Press [Enter] to continue. Else, press [Esc] to cancel.
Once [Enter] has been pressed, PHLASH.EXE automatically updates the computer's BIOS.
After the flashing process completes, the computer automatically reboots itself so changes immediately take effect.
- 6) Remove the system utilities diskette.

EPP3SMC.EXE

EPP3SMC.EXE can be executed as an MS-DOS command or added to the CONFIG.SYS file as a device driver. In either case, use the BIOS Setup utility to set the parallel port to EPP mode.

Video Drivers & Utilities

The following topics describe how to use the video utilities and install video drivers on the computer:

- SMODE.EXE
- SMTR.EXE
- DOS Video Drivers
- Windows 3.x Drivers

Setting High Resolution Mode for the Monitor Display

To use the high resolution modes on the computer, perform the following steps:

- 1) Use the BIOS Setup utility to set correctly the Video System option.
- 2) Use SMTR.EXE from the VGA Utilities and DOS Video Drivers diskette to set correctly a Monitor Type.
- 3) Use Windows Setup to copy the appropriate video driver into Windows.



CAUTION

Do not connect a low resolution monitor to a system that has been configured with high-resolution video drivers. High resolution drivers can damage a 640 x 480 monitor.

SMODE.EXE

The SMODE utility allows the main logic board's video circuitry to emulate and display non-standard VGA modes. With SMODE, you can run software applications written for the following non-VGA modes:

- ◆ Monochrome adapter (MDA)
- ◆ Color graphics adapter (CGA)
- ◆ Expanded graphics adapter (EGA)
- ◆ Hercules monochrome graphics adapter (HGC)

The following procedure describes how to access SMODE:

- 1) Turn on or reboot the computer and allow POST to complete.
- 2) Insert the VGA Utilities and DOS Video Drivers diskette into drive A.
- 3) Type **A:** then press [Enter].
- 4) Type **CD\UTILS** and press [Enter].
- 5) Run the SMODE.EXE utility following the instructions on the monitor screen.

If you want to	Type SMODE followed by	Example
Display a non-standard VGA mode	<hex mode #> VGA	SMODE 55 VGA
Emulate a non-VGA mode	Either EGA, CGA, MDA, or Hercules	SMODE MDA

NOTE VGA modes and corresponding hexadecimal numbers are listed in the release notes supplied with the computer. SMODE MDA allows the main logic board's video circuitry to emulate a monochrome adapter.

SMTR.EXE

The video controller's monitor type selection must match the monitor's available resolution and refresh rates. These monitor resolution and refresh rates are listed in the monitor's support documentation and in the SMTR.EXE utility.



CAUTION

Do not select a monitor type setting that exceeds the monitor's resolution, refresh rate (vertical synchronization) and interlace or non-interlace specifications. Refer to the monitor's support documentation for performance specifications.

To select the correct monitor type:

- 1) Turn on or reboot the computer and allow POST to complete.
- 2) Insert the VGA Utilities and DOS Video Drivers diskette into drive A.
- 3) Type **A:** then press [Enter].
- 4) Type **CD\UTILS** and press [Enter].
- 5) Type **SMTR** and press [Enter].
- 6) Select the correct monitor type following the instructions on the monitor screen.
For example, if you want to run the monitor at a resolution of 1024 768, select 1024x768@70Hz/NI.
- 7) Exit the SMTR.EXE utility following the instructions on the monitor screen.

DOS Video Drivers

These files contain installation instructions and, where applicable, the usage and performance tips for various DOS and CAD applications.

Installing DOS or CAD application video drivers differ with each software application. Specific instructions are located in the README.TXT file and in the appropriate DOS or CAD application directories and files.

Windows 3.x Drivers

These files contain the available S3 Trio 32 (86C732-P) video drivers for Windows 3.x. Depending on how the computer is configured and what software applications are planned to be used, it may be necessary to install one or more of these drivers to optimize the capabilities of the computer.

Before installing a video device driver, read and understand the information in any associated README file.

To install a Windows 3.x video driver, perform the following:

- 1) Type **CD WINDOWS** at the **C:\>** prompt, then press [Enter].
The following prompt appears: **C:\WINDOWS>**.
- 2) Type **SETUP** and press [Enter].
The computer displays the SETUP screen.
- 3) Select the **Display** option and press [Enter].
- 4) Toggle through the **Display** option to select the appropriate Windows 3.x driver.
- 5) Select the desired video resolution then press [Enter].
- 6) If the appropriate video driver resides on a separate diskette, toggle through the **Display** option to select **Other** (Requires disk provided by hardware manufacturer).
- 7) Insert the diskette that contains the appropriate video driver and press [Enter].
- 8) Select the desired video resolution then press [Enter].

NOTE The resolution and refresh rate must be the same as the selection made using the SMTR.EXE utility. The video setup screen appears again with the S3 driver.

- 9) Press [Enter] to accept the configuration.
- 10) The MS-DOS prompt appears when SETUP completes.
- 11) Type **WIN** and press [Enter] to start Microsoft Windows.

BIOS Setup Utility

The information listed below explains how to configure the computer using the BIOS Setup utility. If the computer was delivered with factory-installed software, it has already been configured.

When familiar with utility programs and their uses, refer to the material in the options table while updating the computer. Otherwise, carefully read and understand all the information in this chapter before attempting to modify the computer's configuration settings.

Running the BIOS Setup Utility

The BIOS Setup utility enables to select and permanently store information about the computer's hardware and software in the battery-backed memory of the CMOS RAM. This information takes effect each time the computer boots and can be changed each time you run setup.

Use the BIOS Setup utility when experiencing problems with the hard disk or when there is a need to reconfigure the computer. In addition, the BIOS Setup utility may be used to modify the configuration after adding or removing hardware, or when changing computer settings.

To run the BIOS Setup utility:

- 1) Turn on the computer and allow POST to complete.
- 2) Make a note of any configuration errors listed and then press [**F2**] to display the main menu.
- 3) Follow the instructions on the monitor screen and any on-line help pop-up screens to configure the computer.

NOTE The VENTURIS Pentium computer is currently equipped with a new main logic board that contains a Phoenix 4.04 BIOS.

Additional/modified BIOS Setup utility options are displayed in ***bold italics*** for the Version 2.0 Main Logic Board.

BIOS Setup Menu Fields and Settings often change with new BIOS version releases. Always use on-screen information for the latest BIOS Setup functionality.

Helpful Hints

- ◆ Several keyboard function keys and numeric keypad keys are assigned to help selecting menus and options, change option values and display help information. These keys are displayed at the bottom of the main menu and from the General Help pop-up screen.
- ◆ Item-specific help is available anytime during the setup process and appears at the right of the setup screen each time an option is highlighted. This on-line help provides information about a highlighted option.
- ◆ Select "*Save Changes & Exit*" to save all Setup values.
- ◆ Select "*Discard Changes & Exit*" to exit Setup without recording any changes.
- ◆ Select "*Get Default Values*" to set all Setup options to their default values.
- ◆ Select "*Load Previous Changes*" to restore all CMOS values from the last session.
- ◆ Select "*Save Changes*" to save all selections without exiting Setup.
- ◆ Press [**Esc**] to exit the Setup utility.

BIOS Setup Utility Options

Specific notes pertaining to some Setup options may be obtained by clicking on colored entries in the "Menu Field" column below and/or by clicking on the icons in the rightmost column.

Main Menu Options

<i>Menu Fields</i>	<i>Settings</i>	<i>Comments</i>
System time	Current time	Displays the current time.
System date	Current date	Displays the current date.
Language	English Español Français Deutsch Italiano	This field only displays the current language of the BIOS. The setting can not be changed in Setup. Instead, you must use PHLASH** to change the BIOS, where ** is the language extension The BIOS Setup utility supports only one language per computer.
Diskette A, B	Not Installed 360 KB, 5¼" 1.2 MB, 5¼" 720 KB, 3½" 1.44 MB, 3½" 2.88 MB, 3½"	Sets the size and density of diskette drives.
System memory	Not user selectable	Displays the amount of base (conventional) memory each time the computer boots.
Extended memory	Not user selectable	Displays the amount of extended memory each time the computer boots.

Boot Options

<i>Menu Fields</i>	<i>Settings</i>	<i>Comments</i>
Boot sequence	A: only A: then C: C: then A: C: only	Each time the computer boots, it will load the operating system from the sequence selected.
SETUP prompt	Enabled Disabled	Enables or disables the <F2> setup prompt each time the computer boots. When Disabled is selected, only the prompt informing you when to press <F2> to enter Setup is disabled. Setup may still be entered by pressing <F2> before POST completes.
POST errors	Enabled Disabled	Enabling this options causes the computer to pause and display a setup entry or resume the boot prompt if an error occurs at boot. Disabling this option causes the computer to always attempt to boot regardless of a setup error.
Floppy check	Enabled Disabled	Enabling this option causes the computer to verify the diskette type each time the computer boots. Disabling this option speeds up the boot process.

Boot Options (continued)

Menu Fields	Settings	Comments
Summary screen	Enabled Disabled	Enabling this option causes the computer to display configuration parameters (in the form of a summary screen) during boot.

Fixed Disk Setup OptionsIDE Adapter 0/1 Master/Slave

Menu Fields	Settings	Comments
Autotype fixed disk		Press [Enter] to detect and fill in the installed hard disk drive parameters in the remaining fields.
Type⁽¹⁾	None to 39 User	Selecting None to 39 automatically fills in the remaining fields in this menu. Selecting User prompts to fill in the remaining fields with the installed hard disk drive's parameters. ⁽²⁾
Cylinders⁽¹⁾	0 to 4095	Displays the number of cylinders.
Heads⁽¹⁾	1 to 64	Displays the number of heads.
Sectors/track⁽¹⁾	0 to 63	Displays the number of sectors/tracks.
Landing zone	0 to 4095	Displays the resting or park position of the heads when the HDD is inactive.
Write precomp⁽¹⁾	0 to 4095 None	Displays the number of cylinders that have their write timing changed.
Multi-sector transfers	2 sectors 4 sectors 8 sectors 16 sectors Auto Disabled	Determines the number of sectors per block for multiple sector transfers. Auto refers to the size the disk returns when queried.
LBA control mode	Disabled Enabled	Enabling LBA causes logical block addressing to be used instead of cylinders, heads and sectors. This option allows to select Disabled for IDE hard disk drives up to 528 MB. When using IDE drives greater than 528 MB and MS-DOS or MS-Windows as the operating system, select Enabled. Select Disabled for all other operating systems.
32 bit I/O	Enabled Disabled	Enables or disables 32-Bit data transfer with the IDE HDD. If enabled, Read Ahead Mode is enabled and cannot be changed by the user. This is recommended when using the PCI IDE connector.
Transfer mode	Standard Fast PIO1 Fast PIO2 Fast PIO3	Selects the method to transfer data to and from the HDD. When selecting the user autotype for the HDD, Setup automatically selects the optimum transfer mode is selected.
Read ahead mode	Enabled Disabled	When enabled, the read ahead buffer in the local bus IDE controller increases HDD performance. Enabled is selected automatically if 32-Bit I/O is enabled.

⁽¹⁾ These fields are automatically filled in if the computer auto-detected an installed hard disk drive.⁽²⁾ Incorrect settings can cause the computer to malfunction.

Keyboard Features

<i>Menu Fields</i>	<i>Settings</i>	<i>Comments</i>
NumLock	Auto On Off	Turns NumLock on or off each time the computer boots. Note: When Auto has been selected, the computer will turn on NumLock if it detects a numeric keypad.
Key click	Disabled Enabled	Enables or disables the audible key click feature.
Keyboard auto-repeat rate	2/sec 6/sec 10/sec 13.3/sec 18.5/sec 21.8/sec 26.7/sec 30/sec	Sets the number of times a second to repeat a keystroke while holding the key down.
Keyboard auto-repeat delay	1/4 sec 1/2 sec 3/4 sec 1 sec	Sets the delay time after a key is held down before it begins to repeat a keystroke.

Memory and Cache Options

<i>Menu Fields</i>	<i>Settings</i>	<i>Comments</i>
Internal cache	Enabled Disabled	Enables or disables the computer's internal cache.
External cache	Enabled Disabled	The computer's external cache operates in write-back mode when Enabled has been selected. For optimal computer performance, keep this setting at Enabled.
System BIOS shadow	Not user selectable, permanently set to Enabled.	The main logic board reserves an area of DRAM for a copy of system BIOS ROM. This DRAM called "shadow memory" is write-protected and has the same addresses as the system BIOS ROM locations. When system BIOS ROM is shadowed, the ROM information is copied into an appropriate area in DRAM. This increases the computer's performance because the system BIOS instructions are in fast DRAM instead of ROM.
Cache system BIOS	Enabled Disabled	This option enables the system BIOS to be cached in the internal cache and external cache (if installed). This increases computer performance because BIOS instructions can be executed in cache instead of RAM.
Cache video BIOS	Enabled Disabled	This option enables the video BIOS to be cached in the internal cache and external cache (if installed). This increases computer performance because video BIOS instructions can be executed in cache instead of RAM.

Memory and Cache Options (continued)

Menu Fields	Settings	Comments
Video BIOS shadow	Enabled Disabled	The main logic board reserves an area of DRAM for a copy of video BIOS ROM. This DRAM called "shadow memory" is write-protected and has the same addresses as the video BIOS ROM locations. When shadowing video BIOS ROM, the ROM information is copied into an appropriate area in DRAM. This increases the computer's performance because the video BIOS instructions are in fast DRAM instead of ROM. For PCI VGA cards, video BIOS is always shadowed, regardless of this field's setting.
Shadow 16K at: C8000h CC000h D0000h D4000h D8000h DC000h	Enabled Disabled	Allows to enable or disable shadowing of individual segments of ROM to increase computer performance. Caution: Some option ROMs do not operate properly when shadowed.
AT bus space	Disabled F80000h, 0.5 MB F00000h, 1 MB	Memory hole not available upper memory is contiguous. Sets the memory hole at address F80000 with 0.5 MB memory available. Sets the memory hole at address F00000 with 1 MB memory available.
Extended memory report	Compatibility Non-compatibility	Selects the BIOS report mechanism for memory amount. Select Compatibility when using a conventional operating system. Select Non-Compatibility for extended memory above 64 MB under Windows NT.

Advanced Chipset Control

Menu Fields	Settings	Comments
PCI slot 1 latency timer	Default 08h - F8h	Select Default or a value from 08h to F8h to set the PCI device's latency timer. Default uses the PCI device's power on setting.
PCI slot 2 latency timer	Default 08h - F8h	Select Default or a value from 08h to F8h to set the PCI device's latency timer. Default uses the PCI device's power on setting.
VGA palette snoop	Enabled Disabled	This option controls how VGA devices handle accesses to their palette areas. Enabling this option causes special palette behavior (a device must not respond to normal accesses). Disabling this option causes a device to treat palette accesses like any other device access. Enable VGA Palette Snoop when a second video adapter is connected to the feature connector of the installed VGA adapter for multi-media devices.

Advanced Chipset Control (continued)

<i>Menu Fields</i>	<i>Settings</i>	<i>Comments</i>
VGA feature connector	Enabled	Use with VGA add-in cards to inform card not to claim VGA palette writes.
	Disabled	Use to inform VGA add-in cards to claim VGA palette writes.
Onboard VGA IRQ	Enabled	Select Enabled if the application requires VGA IRQ.
	Disabled	

Integrated Peripherals

<i>Menu Fields</i>	<i>Settings</i>	<i>Comments</i>
Mouse port	Disabled	Enables or disables the mouse port.
	Enabled	
Parallel port	Auto	Enables or disables the onboard port at the specified address. Note: Two devices cannot share the same IRQ. Also, choosing disable makes the parallel port unusable.
	Disabled 3BC, IRQ 7 378, IRQ 7 278, IRQ 5	
Parallel port mode	Compatible	Standard printer connection.
	Bi-directional	PS/2 compatible mode and able to receive data.
	EPP 1.7 EPP 1.9	Enhanced parallel port mode. Selection based on what EPP version the printer supports. EPP 1.9 is IEEE 1284 compliant. Only choose a mode that the parallel port device (such as a printer) supports. Check the parallel port device documentation for this information. When unsure or unable to locate this information, use the default setting.
	ECP-DMA1 ECP-DMA3	Extended capabilities port modes. Selecting either of these modes enables the hard disk drive to copy information without using the CPU. Caution: Before using either of these modes, make sure to have a DMA drive. In addition, make sure the main logic board's chip sets, BIOS and operating system support ECP-DMA.
Serial port 1	Auto	Enables or disables onboard serial port 1 at the specified address. Select Auto unless when having interrupts IRQ 4 and/or IRQ 3 allocated as a computer resource. Two devices cannot share the same IRQ. Choosing Disable makes serial port 1 unusable. When selecting Auto, Setup configures COM1 to address = 3F8h and IRQ = 4.
	Disabled 3F8, IRQ 4 2F8, IRQ 3 3E8, IRQ 4 2E8, IRQ 3	

Integrated Peripherals (continued)

Menu Fields	Settings	Comments
Serial port 2	Auto Disabled 3F8, IRQ 4 2F8, IRQ 3 3E8, IRQ 4 2E8, IRQ 3	Enables or disables onboard serial port 2 at the specified address. Select Auto unless interrupts IRQ 4 and/or IRQ 3 have been allocated as a computer resource. Two devices cannot share the same IRQ. Choosing Disable makes serial port 2 unusable. When Auto has been selected, Setup configures COM2 to address = 2F8h and IRQ = 3.
Diskette controller	Enabled Disabled	Enables or disables the onboard diskette controller.
Monitor	Auto Color Monochrome	Sets color or monochrome as the monitor. Auto is for auto detection. If Auto fails to set the monitor correctly, use this field to change the setting of the monitor.
Plug and Play	Yes No	Select Yes when using a Plug and Play operating system, such as Windows 95. Otherwise, select No.
Reset configuration data	Yes No	Select Yes to clear the computer's resource configuration data and No not to clear it. Setting this field to Yes is useful should the computer's resource configuration ever be destroyed or corrupted. The Yes setting forces the computer to clear its current resource and Plug and Play information and thereby prevent resource conflicts. Once the computer's resource configuration is erased the BIOS then automatically sets the field back to No so as to prevent further erasures.
Video system	EGA / VGA CGA 80x25 Monochrome	Sets the video controller type.
Exchange diskette drives	Disabled Enabled	Enables to logically exchange physical diskette drive designations.
Diskette write protection	Disabled Enabled	Enables or disables diskette drive's write protect option.
IDE adapter 0 IDE adapter 1	Enabled Disabled	Enables or disables the onboard IDE 0/1 controller.

Large Disk Access Mode

Menu Fields	Settings	Comments
Large Disk Access Mode	DOS Other	Select DOS when MS-DOS has been installed. Select Other when another operating system has been installed. A large disk drive constitutes one that has more than 1024 cylinders, 16 heads, or 63 tracks per sector.

Power Options

<i>Menu Fields</i>	<i>Settings</i>	<i>Comments</i>
Power management	Enabled Disabled	Enable this field to use any of the power management options. If this field is enabled and the other fields are disabled, only minimal power reduction is affected. Note: To use any of the Power management features, the POWER.EXE driver must be loaded from the CONFIG.SYS file when booting the computer. This is done automatically if the computer has factory-installed software. Otherwise, include the "DEVICE=C:\DOS\POWER.EXE" statement to the CONFIG.SYS file.
System standby timer	Disabled 1 min. 5 min. 10 min. 20 min. 30 min.	After a set period of computer inactivity, the BIOS places the computer in a standby state (medium power savings), that is, the monitor and CPU are set to power management. Any mouse or keyboard activity quickly returns the computer to operation. Alternately, this option may be disabled. Power management must be enabled to use this option.
System suspend timer	Disabled 1 hour 1.5 hour 2 hour 3 hour 6 hour 12 hour	After a set period of computer inactivity, the BIOS places the computer in a suspended state (maximum power savings), that is, the monitor and fan are shut off and the CPU and hard disk are powered down. Any mouse or keyboard activity quickly returns the computer to operation. When setting a timer for the field, Power Management should be set to Enabled. Alternately, this option may be disabled. Power management must be enabled to use this option.
Quick suspend	Disabled [Ctrl-Alt-Esc] [Ctrl-Alt-Scroll Lock] [Ctrl-Alt-F1 - F10] [Ctrl-Alt-1 - 0]	Enabling this option enables to suspend the computer immediately by pressing the selected key sequence for the Quick Suspend Lock setting. Keyboard or mouse activity unlocks the keyboard and mouse unless Suspend Lock System has been enabled.
Suspend lock system	Yes No	When enabled, the Quick Suspend keyboard sequence can be pressed (for example: [Ctrl] + [Alt] + [Esc]) to lock both the mouse and keyboard and put the computer into system suspend. Alternately, the computer can go into Suspend Lock when the computer reaches the time period set in the System Suspend Timer. To enable Suspend Lock System: Set a Supervisor Password and a User Password to enable Power Management. Select a Quick Suspend sequence. If you want computer inactivity to also trigger the Suspend Lock System feature, enter a time period for System Suspend Timer. To wake up the computer, enter the Supervisor Password. Alternatively, a User Password can be entered, when it has been set.

Security Options

<i>Menu Fields</i>	<i>Settings</i>	<i>Comments</i>
Supervisor password is	Enabled Disabled	Tells whether or not the supervisor's password is enabled or disabled.
User password is	Enabled Disabled	Tells whether or not the user's password is enabled or disabled.
Set supervisor password	Press [Enter]	Enables to set a supervisor password. Set the supervisor password to allow the user password to be used. When the supervisor later enters his password, all user selectable features are accessible. Note: Entering Setup with a supervisor password provides full access to all BIOS Setup utility menus. To delete or disable the Supervisor password, press [Enter] for this field. When prompted for the Supervisor password, leave the field blank and press [Enter].
Password on boot	Enabled Disabled	Enables or disables the enter password on boot option. Note: This option requires prior setting of the supervisor/user password.
Fixed disk boot sector	Normal Write protect	Enables to write protect the boot sector on the hard disk drive. Selecting Write Protect can prevent boot sector viruses from being copied onto the hard disk drive.
Network server	Enabled Disabled	Enabling this option keeps the computer from being accessed during network operation.
System backup reminder	Disabled Daily Weekly Monthly	Enables or disables the system backup reminder message.
Custom sign on banner is	Not user selectable	Tells if the custom sign on banner is enabled or disabled.
Set user password	Press [Enter]	Enables to set a user password. This password can only be set if a supervisor password has been entered. When the user has entered his or her name but the supervisor is not logged in, only the following information is accessible: Supervisor password is Enabled. User password is Enabled. Set user password [press enter] to enter a user password. Password on boot Enabled/Disabled (which ever is in effect). This option is not allowed to change. Custom sign on banner Enabled/Disabled (which ever is in effect). This option is not allowed to change. Note: Entering Setup with a user password restricts access to certain BIOS Setup utility menus. To delete or disable the User password, press [Enter] for this field. When prompted for the User password, leave the field blank and press [Enter]. Also, this option requires prior setting of the supervisor password.

Security Options (continued)

Menu Fields	Settings	Comments
Custom sign on banner	Press [Enter]	Press [Enter] to enter a custom sign on banner that displays during POST. For example, you might enter “ <i>Welcome to John’s machine</i> ”. Up to two lines of text may be entered. The maximum number of characters is 50 per line.
Diskette access	Supervisor User	Enables to control who has access to diskette drives. When Supervisor has been selected, access to the diskette drive is limited to the supervisor, who must enter his or her password. When User has been selected, the diskette can be accessed by entering either the supervisor or the user password. Whatever setting has been chosen, it only becomes functional if a Supervisor Password and a User Password (when User has been chosen for the setting) has been set.
Virus check reminder	Disabled Daily Weekly Monthly	Enables or disables the virus check reminder message.
Keyboard quick lock	Enable Disable	To enable this feature: Set a Supervisor Password and a User Password if desired. Enable Password on Boot. Enable Power Management. Enable Suspend Lock System. Select a keyboard sequence for Quick Suspend. When pressing the keyboard sequence (for example, [Ctrl] + [Alt] + [Esc]), the keyboard and mouse lock and the computer goes into system suspend. To unlock the keyboard and mouse and wake up the computer, enter the Supervisor Password. When also a User Password has been entered, alternatively the User Password can be used to unlock the computer.

Chapter 3

Service Procedures

Safety Requirements

**WARNING**

Static electricity collects on non-conductors such as paper, cloth, or plastic. A static discharge can be damaging even though you often cannot see or feel it.

The following safety precautions must be observed to insure product and personal safety and prevent damage to circuit boards and/or components:

- ◆ Always wear an ESD wrist strap when handling ESD sensitive material and be sure it is properly connected.
- ◆ Keep circuit boards and components away from non-conductors.
- ◆ Keep clothing away from circuit boards and components.
- ◆ Keep circuit boards in anti-static bags.
- ◆ Be cautious when AC power is exposed when working on an assembly.
- ◆ Always use an ISOLATION TRANSFORMER when diagnosing any terminals, monitors or power supplies when AC power is applied.
- ◆ Be cautious of very high voltage potentials when working with monitors.

There should be an approved insulating mat (for technician safety) in front of any workbench where monitors, terminals or power modules are being serviced when power is applied.

NOTE Do NOT wear ESD straps when working on terminals, monitors or power supplies when AC power is applied. This is to avoid the hazard of electrical shock.

Recommended Tools

The following tools will be needed for servicing Digital PC systems. Note that test equipment must be in calibration.

- ◆ Multimeter (4 1/2 digit)
- ◆ A philips screwdriver
- ◆ An antistatic wrist strap

Other Needed Materials

Cleaning agent should be an all purpose cleaner that is used in-house.

Required Special Tools

None.

Remedial Diagnostic Test Software

- ◆ *QAPLUS/fe* , PC Advanced Diagnostic Software, latest version.
Partnumber : 22-00908-06

Recommended Virus Detection and Cleanup Software

- ◆ *F-PROT*, Virus Detection and Cleanup Software, latest version.

Network locations:

North America, South America, Australia and New Zealand:

MINOTR::USER6:[VIRUS.F-PROT]

Europe, Africa, Middle and Far East:

VARDAF::EUROPUB:[VIRUS_SCANNER.F-PROT]

ECO/FCO Information

BIOS version information.

Refer to the Digital DECpc Bulletin Board Support , for the latest information on BIOS upgrades

Network locations:

North America, South America, Australia and New Zealand:

PCBUHD::DKB300:[WC30.BBSFILES]

Europe, Africa, Middle and Far East:

SUTRA::D6:[PUBLIC].

Unlocking and Removing Cover

**WARNING**

You might injure yourself or damage the computer if you attempt to remove the cover before unplugging ac and monitor power cords.

The computer's cover must be removed prior to installing any hardware option.

To remove the cover:

- 1) Unlock cover.
- 2) Lift both side locks out, then turn towards front of computer to release cover from chassis.
- 3) Carefully slide cover toward front of chassis until it clears lip of front bezel.
- 4) Carefully lift cover from chassis.

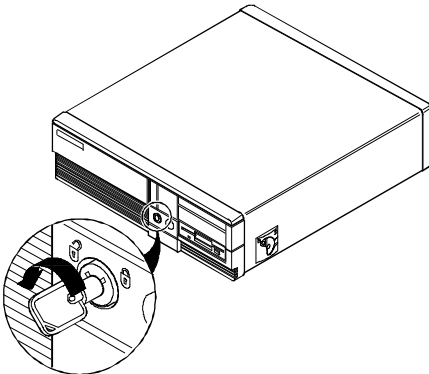

DEC00278-2

Figure 3 - 1 Unlocking the Cover

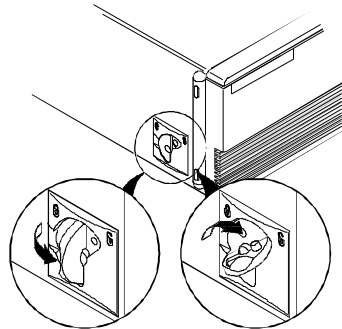

REF00014-2

Figure 3 - 2 Releasing the Cover

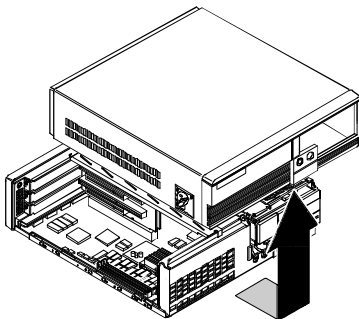

Figure 3 - 3 Removing the Cover

Computer Components

VENTURIS Pentium Slimline Models

<i>Legend</i>	<i>Description</i>
A	Power supply
B	Main logic board
C	3½-inch diskette drive
D	Front access drive bay
E	Front internal drive bay
F	Riser card, ISA/PCI
G	Rear internal drive bay (under power supply)

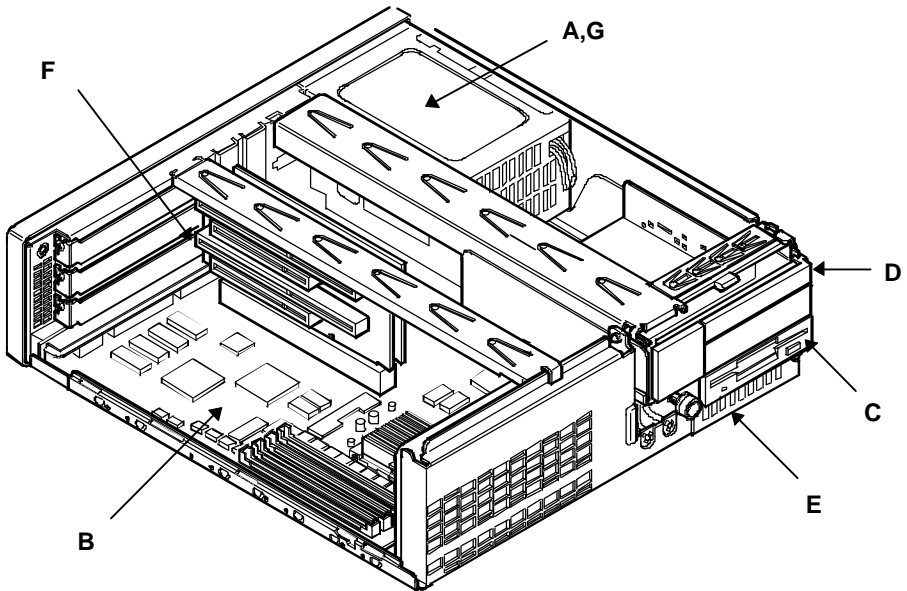
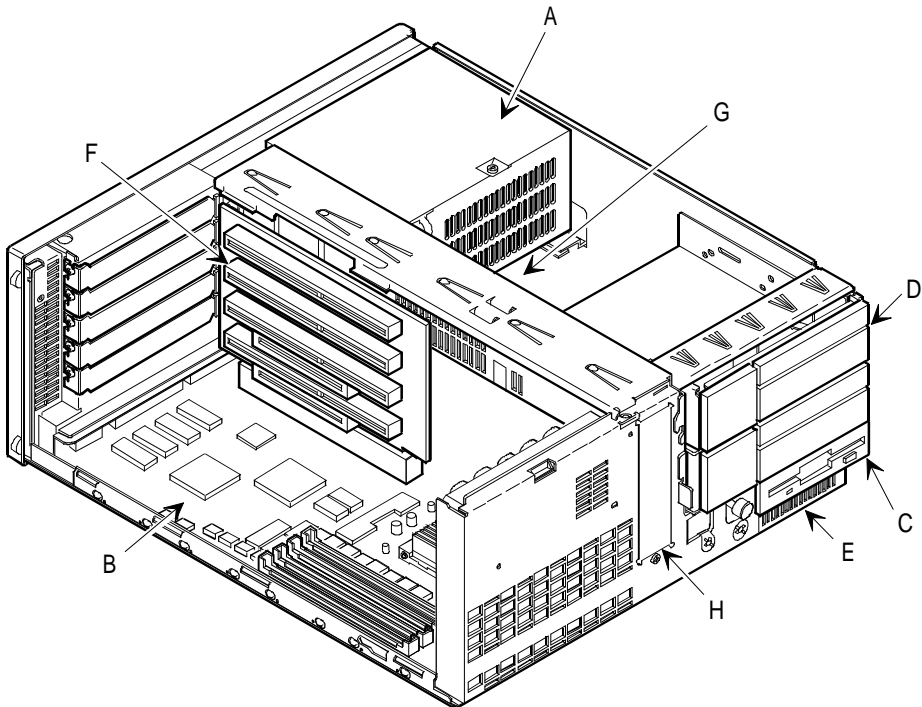

Figure 3 - 4 VENTURIS Pentium Slimline models

VENTURIS Pentium Full Profile Models

Legend	Description
A	Power supply
B	Main logic board
C	3½-inch diskette drive
D	Front access drive bay
E	Front internal drive bay
F	Riser card, ISA/PCI.
G	Rear internal drive bay (under power supply)
H	Front-access drive bay that supports two PCMCIA slots



DEC00682-4

Figure 3 - 5 VENTURIS Pentium Full Profile Models

Expansion Slots

The computer automatically assigns the necessary resources to any installed Plug and Play-compatible expansion board so it operates at maximum performance. If you plan on installing non-Plug and Play expansion boards, it may be necessary to manually set jumpers on the board based on the computer resources already allocated.

VENTURIS Pentium Slimline Models Expansion Slots

The VENTURIS Pentium Slimline riser card contains four slots for installing:

- ◆ Two ISA expansion boards and one PCI expansion board or
- ◆ One ISA expansion board and two PCI expansion boards.

Expansion Slot	Slot Type	Description
J4	ISA	Supports full-length industry-standard 16-bit ISA expansion boards. Uses the top expansion slot at the rear panel.
J3	ISA	Supports full-length industry-standard 16-bit ISA expansion boards. Uses the middle expansion slot at the rear panel. Designated as a shared slot with PCI slot J2.
J2	PCI	Supports full-length 32-bit PCI local bus expansion boards. Uses the middle expansion slot at the rear panel. Designated as a shared slot with ISA slot J3.
J1	PCI	Supports half-length 32-bit PCI local bus expansion boards. Uses the bottom expansion slot at the rear panel.

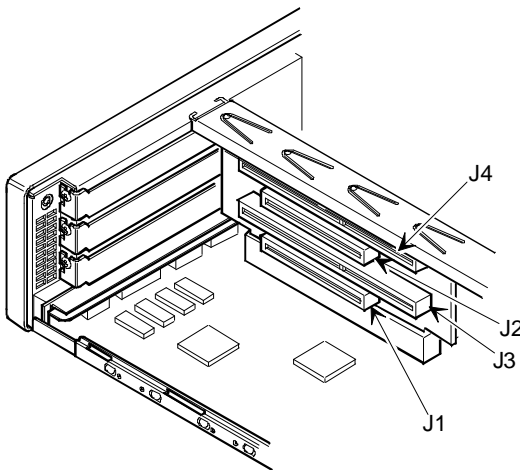

Figure 3 - 6 VENTURIS Pentium Slimline Expansion Slots

VENTURIS Pentium Full Profile Models Expansion Slots

The VENTURIS Pentium Full Profile riser card contains six slots for installing:

- ◆ Four ISA expansion boards and one PCI expansion board or
- ◆ Three ISA expansion boards and two PCI expansion boards.

Expansion Slot*	Slot Type	Description
J4 - J6	ISA	Supports full-length industry-standard 16-bit ISA expansion boards Uses the top three expansion slots at the rear panel
J3	ISA	Supports full-length industry-standard 16-bit ISA expansion boards Uses the fourth expansion slot at the rear panel Designated as a shared slot with PCI slot J2 ⁽¹⁾
J2	PCI	Supports full-length 32-bit PCI local bus expansion boards Uses the fourth expansion slot at the rear panel Designated as a shared slot with ISA slot J3 ⁽¹⁾
J1	PCI	Supports half-length 32-bit PCI local bus expansion boards Uses the bottom expansion slot at the rear panel

⁽¹⁾ Only one expansion board can reside in slot J2 and J3 at any one time. These slots have to share the fourth expansion slot opening at the rear panel, thus, a maximum of five expansion boards can be supported at any one time.

* Expansion slot numbers are designated J(n) as silk-screened on the riser card; not to be confused as jumper numbers.

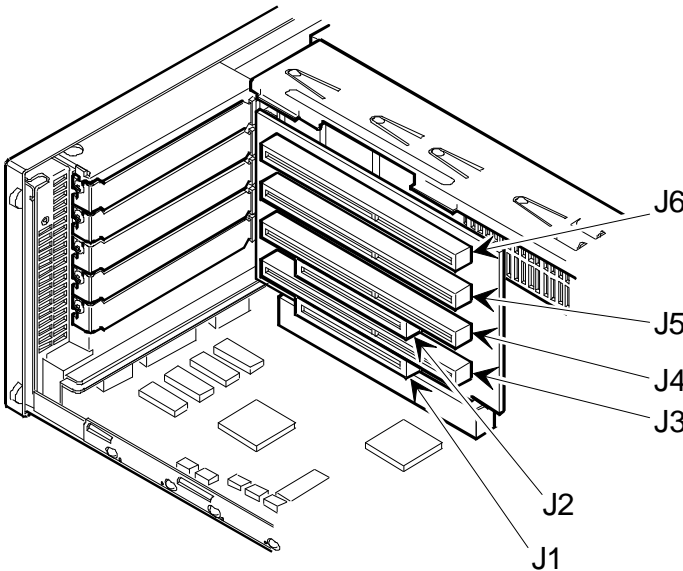

Figure 3 - 7
VENTURIS
Pentium Full
Profile Expansion
Slots

Main Logic Board Jumpers

Jumper pins allow to set specific computer parameters. They are set by changing the pin location of jumper blocks. Note that the square pin of each jumper block is pin 1. A jumper block is a small plastic-encased conductor (shorting plug) that slips over the pins. To change a jumper setting, remove the jumper from its current location. Place the jumper over the two pins designated for the desired setting. Press the jumper evenly onto the pins. Be careful not to bend the pins.



CAUTION

Do not touch any electronic component unless you are safely grounded. Wear a grounded wrist strap or touch an exposed metal part of the system box chassis. A static discharge from your fingers can result in permanent damage to electronic components.

VENTURIS 560 Models Main Logic Board Jumper Settings

Settings shown in *bold italics* are factory defaults.

Feature	Description	Setting
Discharge	<i>Normal</i> Clear CMOS	<i>J22, pins 1 and 2 jumpered</i> <i>J22, pins 2 and 3 jumpered</i>
Password clear	Password clear (MFG test) <i>Normal mode</i>	J24, jumpered <i>J24, open</i>
Recovery mode	Recovery mode <i>Normal</i>	J25, jumpered <i>J25, open</i>

VENTURIS 560 Models Main Logic Board Jumper Locations

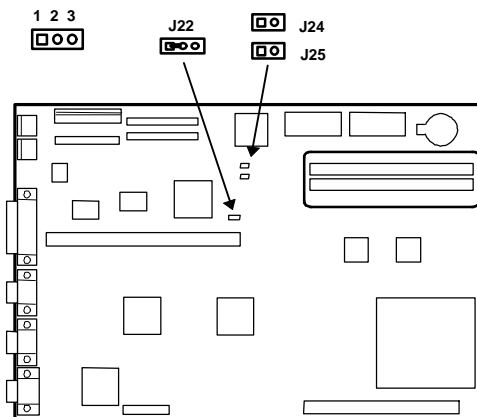

Figure 3 - 8 VENTURIS 560 Main Logic Board Jumpers Locations

VENTURIS Pentium version 1.0 Main Logic Board Jumper Settings

Settings shown in *bold italics* are factory defaults.

Feature	Description	Setting
CPU clock		
75 MHz	50 MHz	J21 & J22 open
90 and 120 MHz	60 MHz	J21 open, J22 jumpered
100 and 133 MHz	66MHz	J21 & J22 jumpered
CPU core/bus frequency ratio		
75, 90 and 100 MHz	3/2	J27 open
120 and 133 MHz	2/1	J27 jumpered
Recovery mode	<i>Normal</i>	<i>J10 open</i>
	Recovery mode	J10 jumpered
Password clear	<i>Normal mode</i>	<i>J11 open</i>
	Password clear (MFG test)	J11 jumpered
CMOS clear	<i>Normal</i>	<i>J16 pins 1 and 2 jumpered</i>
	Discharge	J16pins 2 and 3 jumpered

VENTURIS Pentium version 1.0 Main Logic Board Jumper Locations

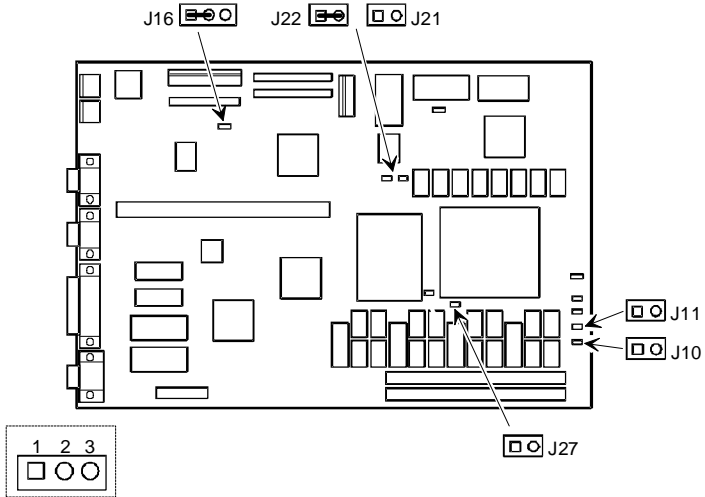

Figure 3 - 9 VENTURIS Pentium version 1.0 Main Logic Board Jumper Locations

VENTURIS Pentium version 2.0 Main Logic Board Jumper Settings

Settings shown in *bold italics* are factory defaults.

Feature	Description	Setting
CPU clock		
75 MHz	50 MHz	J21 & J22 open
90, 120, 150 and 180 MHz	60 MHz	J21 open, J22 jumpered
100, 133, 166 and 200 MHz	66 MHz	J21 & J22 jumpered
CPU core/bus frequency		
75, 90 and 100 MHz	3/2	J25& J27 open
120 and 133 MHz	2/1	J25 open, J27 jumpered
150 and 166 MHz	5/2	J25 & J27 jumpered
180 and 200 MHz	3/1	J25 jumpered, J27 open
Recovery mode	<i>Normal</i>	<i>J10 open</i>
	Recovery mode	J10 jumpered
Password clear	<i>Normal mode</i>	<i>J11 open</i>
	Password clear (MFG test)	J11 jumpered
Discharge CMOS Note: on some versions of this board, J16 is not installed.	<i>Normal operation</i>	<i>J16 pins 1 and 2 jumpered</i>
	Discharge CMOS	J16pins 2 and 3 jumpered
Voltage regulator setting	<i>VR/STD CPU voltage</i>	<i>J35 open</i>
	VRE CPU voltage	J35jumpered
Boot block write enable (see Caution)	<i>Disabled</i>	<i>J32 pins 2 and 3 jumpered</i>
	Enabled	J32 pins 1 and 2 jumpered



CAUTION

Use of the BIOS boot block jumper is normally reserved for factory use only. Keep this jumper in the factory default (disabled) position at all times. Unauthorized use can cause the computer to operate incorrectly.

VENTURIS Pentium version 2.0 Main Logic Board Jumper Locations

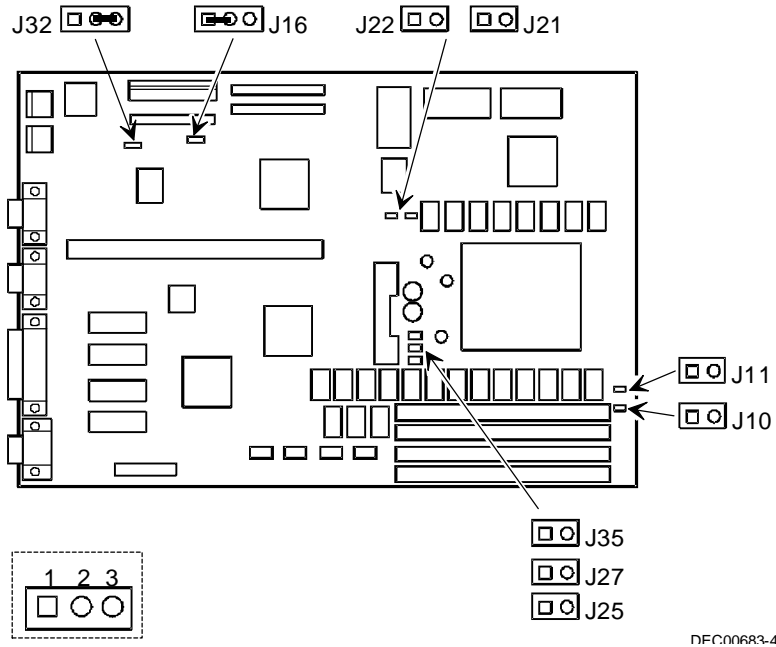

Figure 3 - 10 VENTURIS Pentium version 2.0 Main Logic Board Jumper Locations

Computer Memory Configurations

Adding more memory allows the computer to run larger, more complicated software and to run it faster.

VENTURIS 560 Memory Configurations

The VENTURIS 560 computer comes with at least 4 MB of memory. This amount can be increased up to 64 MB. However, when adding additional memory make sure to:

- ◆ Install 32-bit SIMMs having an access time of 70 ns or less.
- ◆ Fill one or two sockets using the same SIMM size, type and speed for socket 0 and 1.
Supported SIMM sizes: 4 MB, 8 MB, 16 MB, and 32 MB.
- ◆ Fill socket 0 before 1.

<i>Socket 0</i>	<i>Socket 1</i>	<i>Total</i>
4 MB		4 MB
8 MB		8 MB
4 MB	4 MB	8 MB
8 MB	8 MB	16 MB
16 MB		16 MB
16 MB	16 MB	32 MB
32 MB		32 MB
32 MB	32 MB	64 MB

VENTURIS 560 SIMM Sockets Locations

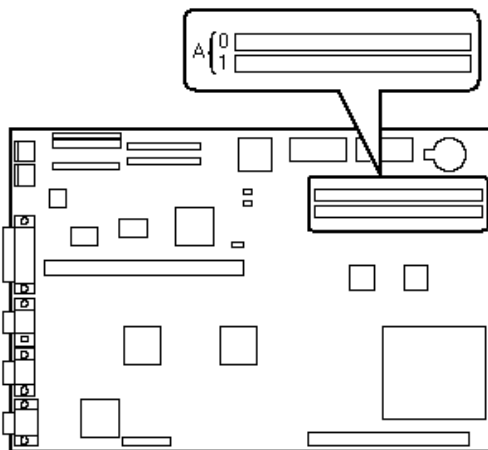

**Figure 3 - 11 VENTURIS 560
SIMM Sockets Locations**

VENTURIS Pentium version 1.0 board Memory Configurations

The VENTURIS Pentium version 1.0 board computer comes with 8 MB of memory hardwired to the main logic board. This amount can be increased up to a maximum of 128 MB using the two SIMM sockets on the main logic board. However, when adding SIMMs make sure to:

- ◆ Install 32-bit SIMMs having an access time of 70 ns or less. Supported SIMM sizes: 4 MB, 8 MB, 16 MB, 32 MB or 64 MB.
- ◆ For improved performance, VENTURIS computers are designed with interleaved memory. This feature requires that both sockets are populated. Ensure that the SIMM in each socket is the same type, size, and speed. Therefore, a 4 MB SIMM in Bank 0 requires a 4 MB SIMM in Bank 1.

<i>Onboard</i>	<i>Bank 0</i>	<i>Bank 1</i>	<i>Total</i>
8 MB			8 MB
8 MB	4 MB	4 MB	16 MB
8 MB	8 MB	8 MB	24 MB
8 MB	16 MB	16 MB	40 MB
8 MB	32 MB	32 MB	72 MB
Disabled	64 MB	64 MB	128 MB

VENTURIS Pentium version 1.0 board SIMM Sockets Locations

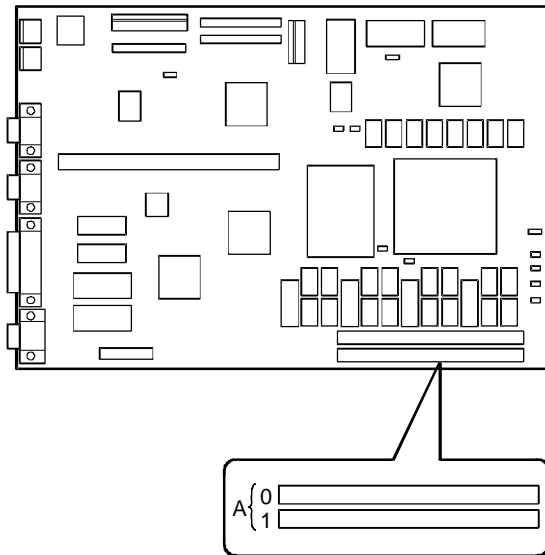

Figure 3 - 12 VENTURIS Pentium version 1.0 board SIMM Sockets Locations

DEC00507-3

VENTURIS Pentium version 2.0 board Memory Configurations

The VENTURIS Pentium version 2.0 board computer comes with 8 MB of memory hardwired to the main logic board. This amount can be increased up to a maximum of 128 MB using the four SIMM sockets on the main logic board (Figure 3 - 13). However, when adding SIMMs make sure to:

- ◆ Install 32-bit SIMMs having an access time of 70 ns or less. Supported SIMM sizes: 4 MB, 8 MB, 16 MB, 32 MB or 64 MB.
- ◆ For improved performance, VENTURIS Pentium computers are designed with interleaved memory. This feature requires that two banks are populated at a time. Ensure that the SIMM in each bank is the same type, size, and speed. Therefore, a 4 MB SIMM in bank 1 requires a 4 MB SIMM in bank 2.

<i>Onboard</i>	<i>Bank 1</i>	<i>Bank 2</i>	<i>Bank 3</i>	<i>Bank 4</i>	<i>Total</i>
8 MB					8 MB
8 MB	4 MB	4 MB			16 MB
8 MB			4 MB	4 MB	16 MB
8 MB	4 MB	4 MB	4 MB	4 MB	24 MB
8 MB	4 MB	4 MB	8 MB	8 MB	32 MB
8 MB	4 MB	4 MB	16 MB	16 MB	48 MB
8 MB	4 MB	4 MB	32 MB	32 MB	80 MB
8 MB	8 MB	8 MB			24 MB
8 MB			8 MB	8 MB	24 MB
8 MB	8 MB	8 MB	4 MB	4 MB	32 MB
8 MB	8 MB	8 MB	8 MB	8 MB	40 MB
8 MB	8 MB	8 MB	16 MB	16 MB	56 MB
8 MB	8 MB	8 MB	32 MB	32 MB	88 MB
8 MB	16 MB	16 MB			40 MB
8 MB			16 MB	16 MB	40 MB
8 MB	16 MB	16 MB	4 MB	4 MB	48 MB
8 MB	16 MB	16 MB	8 MB	8 MB	56 MB
8 MB	16 MB	16 MB	16 MB	16 MB	72 MB
8 MB	32 MB	32 MB			72 MB
8 MB			32 MB	32 MB	72 MB
8 MB	32 MB	32 MB	4 MB	4 MB	80 MB
8 MB	32 MB	32 MB	8 MB	8 MB	88 MB
8 MB	32 MB	32 MB	16 MB	16 MB	104 MB
DISABLED	32 MB	32 MB	32 MB	32 MB	128 MB

VENTURIS Pentium version 2.0 board SIMM Sockets Locations

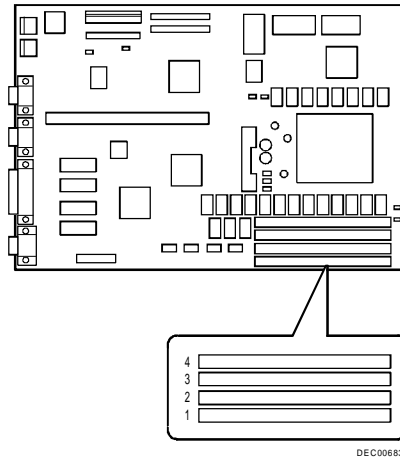

Figure 3 - 13 VENTURIS Pentium version 2.0 board SIMM Socket Locations

VENTURIS 575 E board Memory Configurations

The VENTURIS 575 E computer comes with 8 MB of EDO memory hardwired to the main logic board. This amount can be increased up to a maximum of 128 MB using the two SIMM sockets on the main logic board.

However, when adding SIMMs make sure to:

- ◆ Install 32-bit EDO SIMMs having an access time of 70 ns or less.
Supported SIMM sizes: 4 MB, 8 MB, 16 MB, 32 MB or 64 MB.

<i>Onboard</i>	<i>Bank 0</i>	<i>Bank 1</i>	<i>Total</i>
8 MB			8 MB
8 MB	4 MB	4 MB	16 MB
8 MB	8 MB	8 MB	24 MB
8 MB	16 MB	16 MB	40 MB
8 MB	32 MB	32 MB	72 MB
Disabled	64 MB	64 MB	128 MB

Opening the VENTURIS Slimline Device Bay & Power Supply Subassembly

Open the device bay & power supply subassembly in order to install, remove and/or connect certain components and peripheral devices. To open the subassembly:

- 1) Turn off the computer.
- 2) Disconnect external devices, ac power and monitor power.
- 3) Unlock and remove cover.
- 4) Slide front locking mechanism to right to release subassembly.
- 5) Lift up on subassembly and lock in place.

Figure 3 - 14 Release front locking mechanism

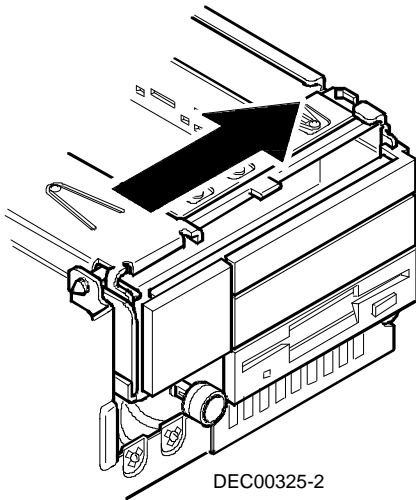
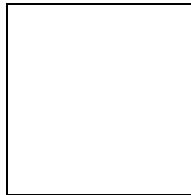

Figure 3 - 15 Lock in place



Opening the VENTURIS Full-Profile Device Bay & Power Supply Subassembly

Open the device bay & power supply subassembly in order to install, remove and/or connect certain components and peripheral devices. To open the subassembly:

- 1) Turn off the computer.
- 2) Disconnect external devices, ac power and monitor power.
- 3) Unlock and remove cover.
- 4) Pull tab (A) toward front of computer to release subassembly.
- 5) Lift up on subassembly and lock in place.

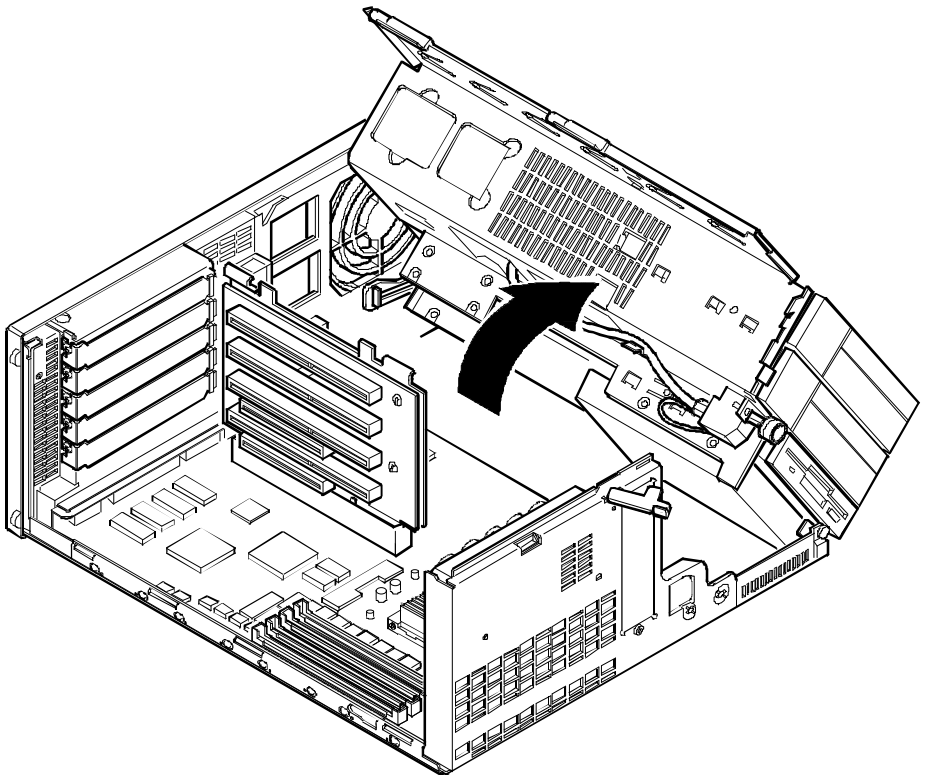

DEC00686-2

Figure 3 - 16 Opening the VENTURIS Full-Profile Device Bay & Power Supply Subassembly

Removing the 3½-Inch Diskette Drive (All Models)

To remove the 3½-inch diskette drive:

- 1) Turn off the computer.
- 2) Disconnect external devices, ac power and monitor power.
- 3) Unlock and remove cover.
- 4) Remove two screws securing the right side of diskette drive to chassis.
- 5) Open the device bay & power supply subassembly.
Refer to “Opening the Device Bay & Power Supply Subassembly”.
- 6) Disconnect power and ribbon cables.
- 7) Remove two screws securing the right side for SL models and left side for FP models of diskette drive to chassis.
- 8) Slide the diskette drive out of the front of the chassis.

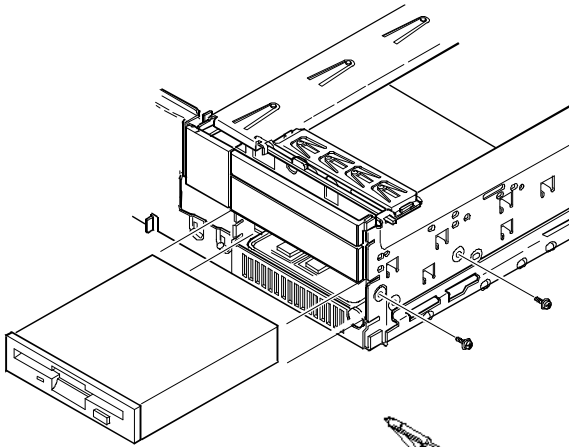

Figure 3 - 17 Removing the 3½-inch diskette drive on the VENTURIS Slim Line models

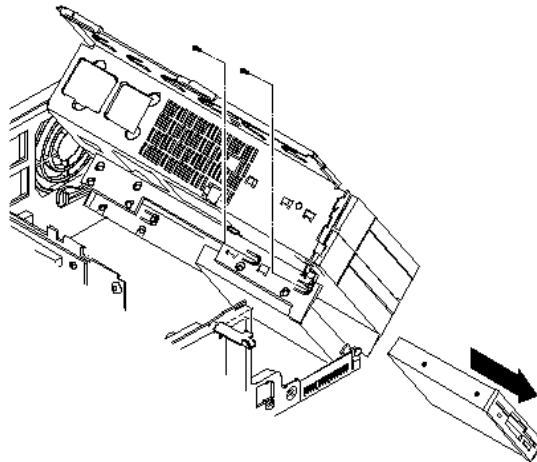

Figure 3 - 18 Removing the 3½-inch diskette drive on the VENTURIS Full-Profile models

Removing the VENTURIS Pentium Main Logic Board

To remove the main logic board:

- 1) Turn off the computer.
- 2) Disconnect external devices, ac power and monitor power.
- 3) Unlock and remove cover.
- 4) Remove all connectors.
- 5) Remove all expansion boards.
- 6) Remove the riser card and bracket.
- 7) Remove screws and lift the board out.

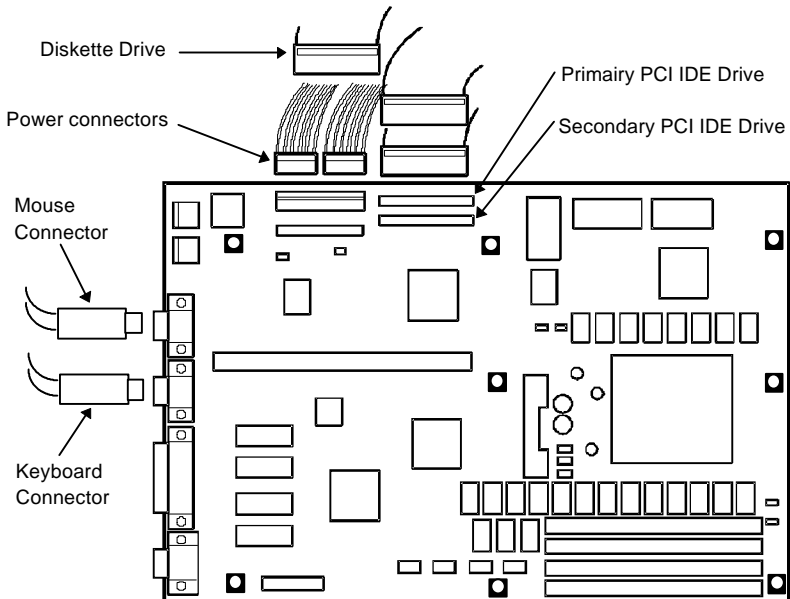

Figure 3 - 19 Removing the VENTURIS Pentium Main Logic Board

Removing the VENTURIS Power Supply

To remove the power supply:

- 1) Perform the steps necessary to open the device bay and power supply subassembly.
- 2) Remove power supply, IDE and diskette cabling from main logic board noting their proper orientation.
- 3) While holding the device bay and power supply subassembly, carefully release the rear latch.
- 4) Carefully slide entire subassembly away from chassis and place upside down on antistatic surface.
- 5) Loosen two screws securing power on/off switch to chassis.
- 6) Remove screws securing power supply to chassis.
- 7) Remove power supply and power on/off switch from the subassembly.

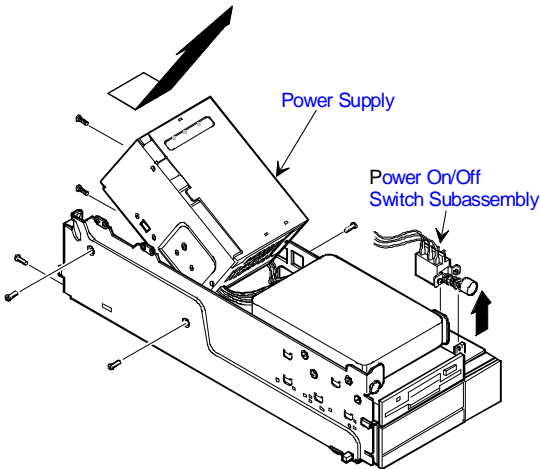

Figure 3 - 20 Removing the Power Supply on the VENTURIS Slimline models

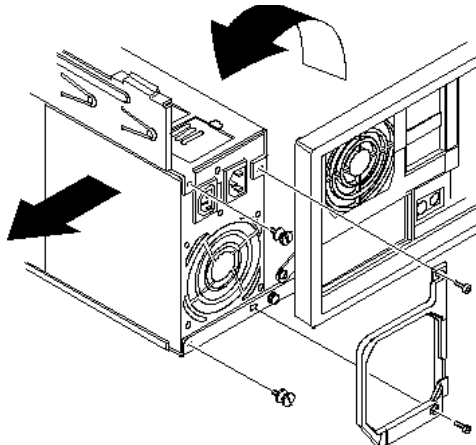

Figure 3 - 21 Removing the Power Supply on the VENTURIS Full-Profile Power Supply

Installation Procedures

Installing a Higher Performance CPU

The VENTURIS Pentium main logic board is equipped with a Pentium processor installed in a ZIF socket. To install a higher performance CPU:

- 1) Turn off the computer.
- 2) Disconnect external devices, ac power and monitor power.
- 3) Unlock and remove cover.
- 4) Lift up on lever to release old CPU.
- 5) Remove old CPU.
- 6) Install new CPU.
- 7) Make sure pin 1 on CPU is aligned with pin 1 on ZIF socket (designation A, Figure 3 - 22).
- 8) Return release lever to its original position and then set all appropriate CPU jumpers.
- 9) Replace and lock cover. Refer to *"Replacing and Locking the Cover"*.
- 10) Connect external devices and restore power.

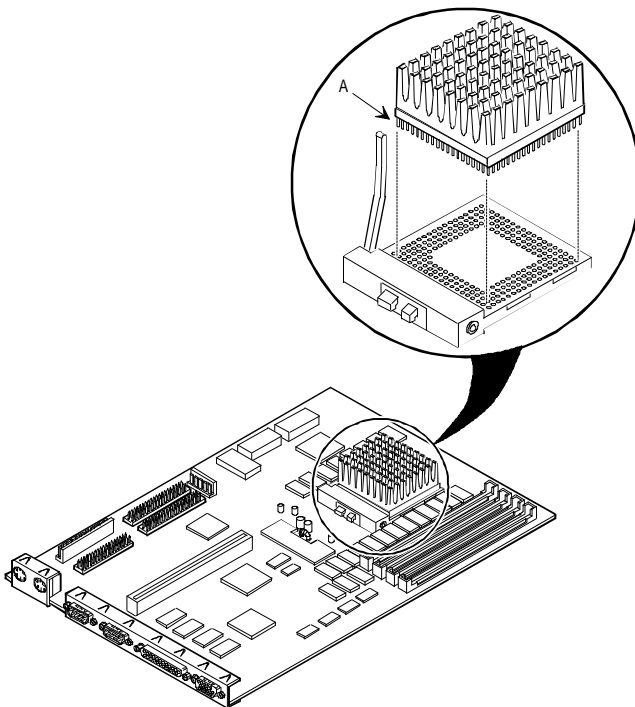

Figure 3 - 22 Installing a Higher Performance CPU

DEC00684-2

Installing Video Memory

The VENTURIS Pentium computer comes standard with 1 MB of video memory. This amount can be increased to 2 MB by installing two, MB video memory DRAM chips in the designated sockets on the main logic board. (The Video Memory upgrade is not possible on the Venturis 575 E models.)

To install the video memory upgrade chip:

- 1) Turn off the computer.
- 2) Disconnect external devices, ac power and monitor power.
- 3) Unlock and remove cover.
- 4) Remove upgrade chips from packaging and install in socket.
- 5) Make sure pin 1 on chip is aligned with pin 1 on socket (A, Figure 3 - 23).
- 6) Replace and lock cover. Refer to “*Replacing and Locking the Cover*”.
- 7) Connect external devices and restore power.
- 8) Run the BIOS Setup utility by rebooting and pressing [F2] before POST completes.
- 9) Select **Save Changes and Exit**.

The computer reboots and now recognizes the amount of new video memory.

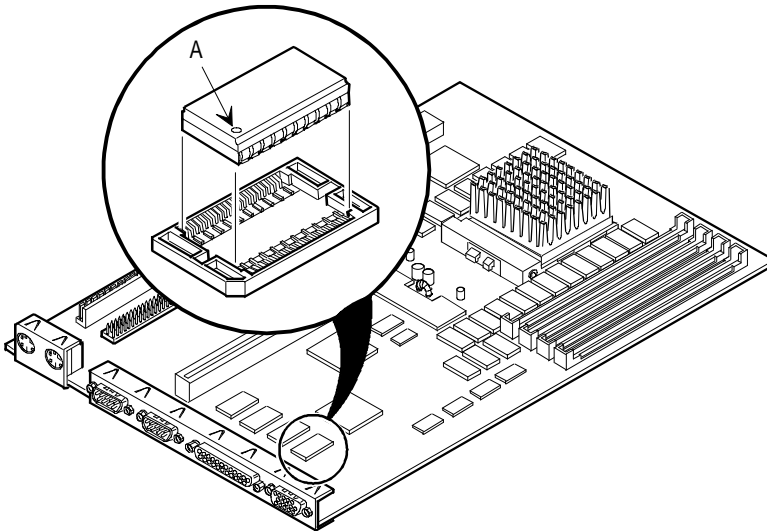

DEC00684-5

Figure 3 - 23 Installing Video Memory

Replacement Procedures

Replacing the Real-Time Clock (RTC)/Lithium Battery

The VENTURIS Pentium computer comes with either a Lithium 3V dc wafer-style battery or a Dallas RTC. If the computer ever fails to retain the correct date, time or configuration settings when it is turned on, replace the installed device.

To replace the RTC, perform the following:

1. Record computer configuration settings using the BIOS Setup utility.
2. Turn off the computer.
3. Disconnect external devices, ac power and monitor power.
4. Remove cover.
5. Carefully extract old RTC from socket.
6. Install new RTC (Digital part number 21-39125-01, Dallas part number DS1287A, or equivalent).
7. Replace and lock cover. Refer to “*Replacing and Locking the Cover*”.
8. Connect external devices and restore power.
9. Run BIOS Setup utility to reconfigure computer using recorded configuration settings from *step 1*.



CAUTION

Make sure pin 1 on RTC is correctly aligned with location on socket (A, Figure 3 - 24). Incorrect installation can cause faulty computer operation.

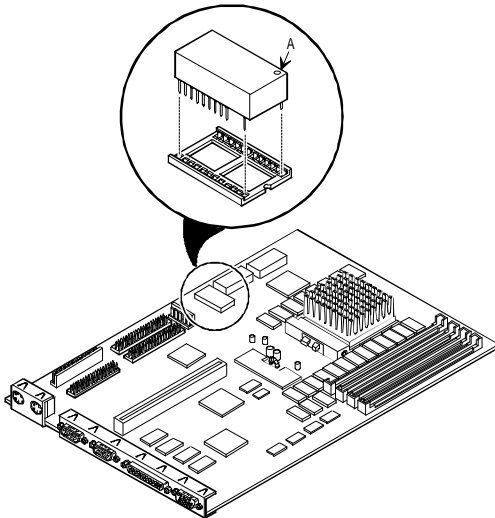

Figure 3 - 24 Replacing the Real-Time Clock

DEC00684-4

To replace the Lithium battery, perform the following:

- 1) Record computer configuration settings using the BIOS Setup utility.
- 2) Turn off the computer, disconnect external devices, ac power and monitor power.
- 3) Remove cover and carefully lift up on retaining clip and remove old battery.
- 4) Install new battery.
- 5) When installing new battery, make sure “+” side faces up.
- 6) Replace cover.
- 7) Connect external devices and restore power.
- 8) Run BIOS Setup utility to reconfigure computer using recorded configuration settings from *step 1*.

**WARNING**

There is a danger of battery explosion if a lithium battery is incorrectly replaced. To prevent damage to the computer, be sure the + side faces up when installing a new battery. Also, be sure to replace the battery with either a Digital (P/N 12-41474-05), Toshiba (P/N CR20302), or equivalent 3 V dc lithium battery. Depending on your locality, the battery might be considered hazardous waste. Make sure to follow any state or local statute to properly dispose of the old battery.

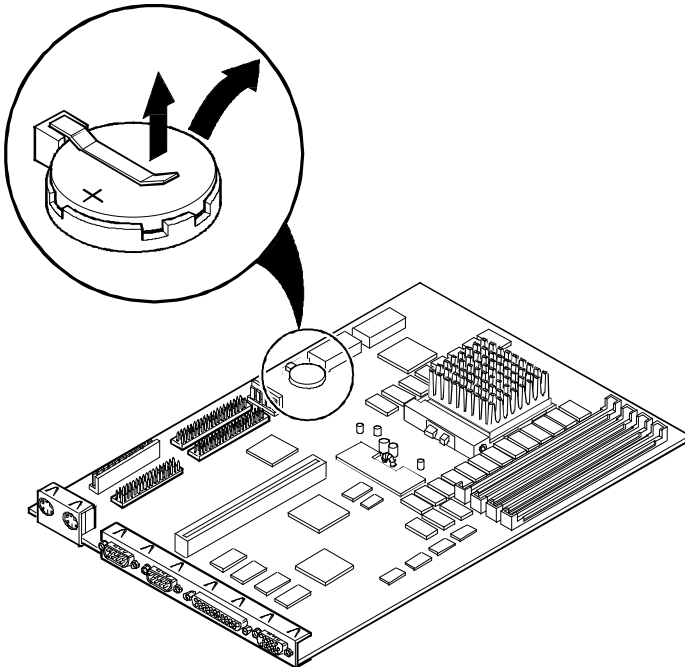

Figure 3 - 25
Replacing the
Lithium Battery

DEC00684-6

Connecting Diskette and IDE Devices

NOTE If only one IDE device is installed, make sure to use the ribbon cable connector furthest from the main logic board connector.

Also, when IDE devices have been installed in both internal drive bays, make sure that the ribbon cable has no twists between the two IDE drives.

To connect diskette and IDE devices, perform the following:

- 1) Unlatch device bay and power supply subassembly.
- 2) Lift up on subassembly and lock in place.
- 3) Connect supplied ribbon cable to appropriate device. If necessary, refer to the illustration in the appropriate data cable connection topic listed below.
- 4) Connect appropriate power cable to device.
- 5) Release device bay and power supply subassembly rear latch.
- 6) Close subassembly and then secure to chassis using front locking mechanism.
- 7) Replace and lock cover.
- 8) Connect external devices and restore power.
- 9) Run BIOS Setup utility to configure computer.

NOTE Make sure the cable is connected with correct orientation. Most cables and sockets are keyed so you cannot connect them backwards. If the cable or device is not keyed, connect pin 1 of cable to pin 1 of device's socket.

Pin 1 of the cable is on the edge with colored stripe. Pin 1 of the device's socket should be marked with a number or symbol at one end of socket or with a number or symbol printed on circuit board near one end of socket. If necessary, refer to the device's documentation for pin 1 orientation.

Diskette Data Cable Connections

Legend	Diskette Drive Component
A	Power supply
B	Power connections
C	Diskette drive connections
D	Main logic board diskette drive connection
E	Diskette drives

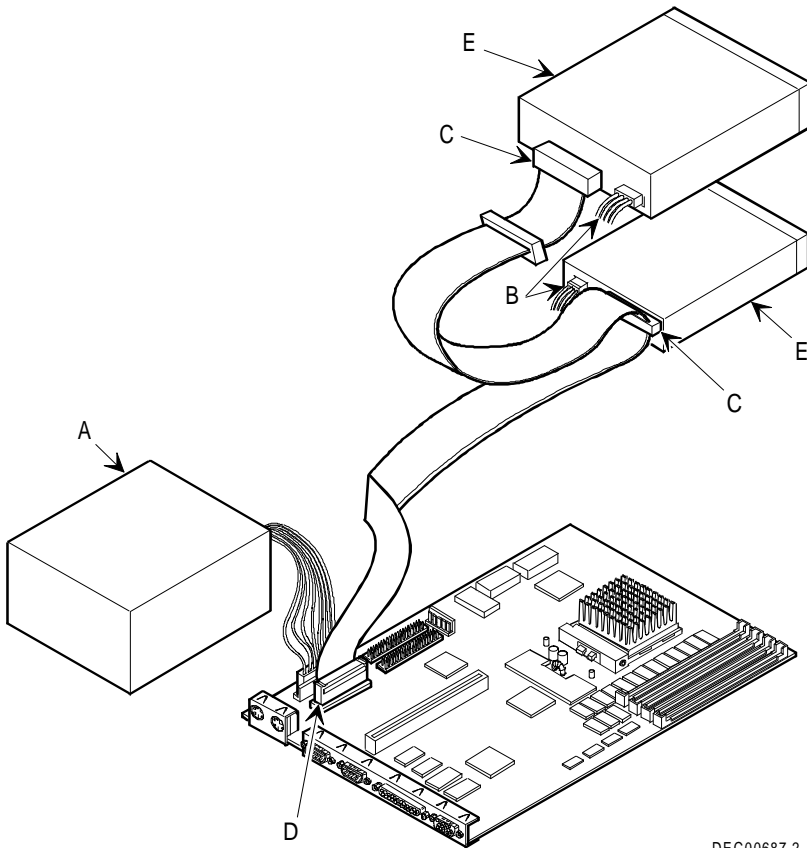

DEC00687-2

Figure 3 - 26 Diskette Drive Data Cable Connections

IDE Data Cable Connections

Legend	IDE Drive Component
A	Power supply
B	Power connections
C	IDE hard disk drive connections
D	Main logic board IDE drive connections
E	IDE hard disk drive
F	IDE CD-ROM drive

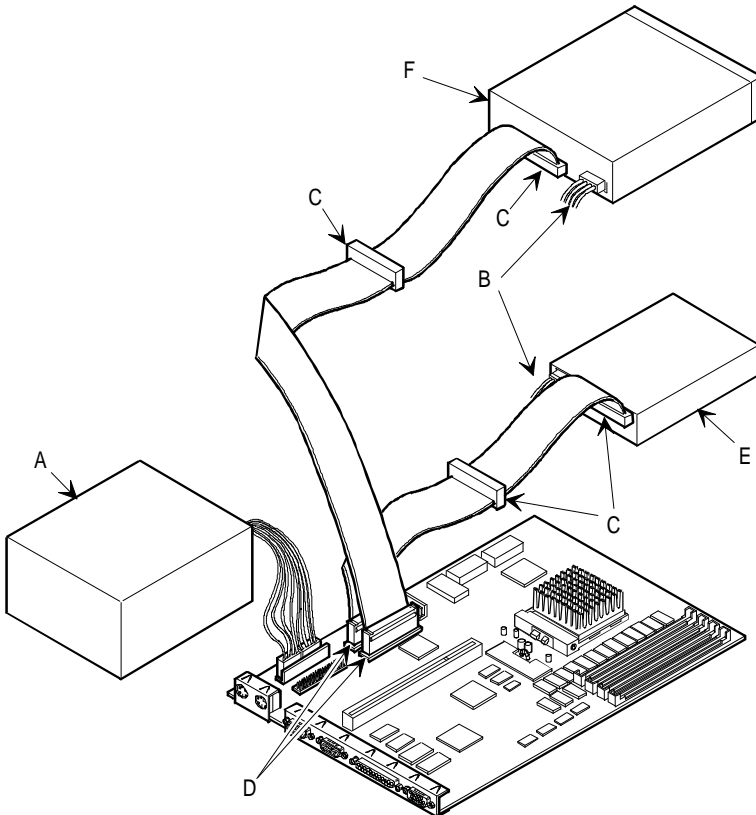

DEC00688-2

Figure 3 - 27 IDE Data Cable Connections

Chapter 4

Troubleshooting

The following pages provide initial troubleshooting procedures and tables listing specific problems, probable causes and recommended actions to take if the computer fails after configuration or after installing optional hardware or software.

Refer to the documentation supplied with additional options when experiencing problems with specific options that have been installed.

Initial Troubleshooting

Follow the following general procedures to troubleshoot the VENTURIS Pentium PC family of computers:

- ◆ Press [Ctrl] + [Alt] + [Del]. If the computer fails to boot, turn it off, wait until all hard disk drives spin down completely and then turn it back on.
- ◆ If the POST detects an error refer to “*Troubleshooting*” and take the appropriate steps to correct the problem. After the problem has been resolved, restart the computer.
- ◆ Run the BIOS Setup utility.
- ◆ Make sure all necessary changes have been made to the CONFIG.SYS and AUTOEXEC.BAT files.
- ◆ Make sure all necessary video, printer and application device drivers are properly installed.
- ◆ Ensure that all cables and connections are secure.
- ◆ Run the *QAPLUS/fe* advanced diagnostic software.
- ◆ If these steps do not identify and/or correct the problem, perform the specific troubleshooting procedures appropriate to the circumstances.

NOTE If you need to return a failed component, pack it in its original container and return it to Digital for service.

Fill in the appropriate fields of the Part Exchange Form with the relevant error information!!

Beep Codes

When POST finds an error and cannot display a message, the computer's speaker emits a series of beeps to indicate the error. During POST, if the video configuration fails or if an external ROM module fails a checksum test, the computer beeps three times.

<i>BeepCode</i>	<i>Error</i>
1 long - 2 shorts	Video configuration fails External ROM module fails a checksum test

The following table lists other fatal error and their associated beep codes.

Each code represents the number of short beeps that are grouped together.

Fatal errors (errors that lock up the computer) are generally the result of a failing main logic board or some of add-on component (SIMM, BIOS, computer battery, etc.).

<i>BeepCode</i>	<i>Error</i>
2-2-3	BIOS ROM checksum
3-1-1	Test DRAM refresh
3-1-3	Test keyboard controller
3-4-1	Test 512K base address lines
3-4-3	Test 512K base memory
2-1-2-3	Check ROM copyright notice
2-2-3-1	Test for unexpected interrupts

POST and Boot Messages

The POST displays messages to alert to errors in hardware, software and firmware or to provide operating information about the computer.

Each time the POST displays a message on the screen, the computer's speaker beeps twice. If an error occurs before the monitor is initialized, specific beep codes sound to alert to a problem. The following table lists a general grouping of system messages. In addition, each message is accompanied by text describing the message and in most cases, a recommended solution to the problem.

NOTE *Italics* indicate variable parts of a message such as memory addresses, hexadecimal values and so on.

These messages can differ at each occurrence.

POST and Boot Messages (continued)

Message	Description/Solution
nnnn Cache SRAM Passed	Where <i>nnnn</i> is the amount of computer cache (in kilobytes) that tested successfully.
Diskette drive A error Diskette drive B error	Run the BIOS Setup Utility. Check all connections. If the problem persists-replace the diskette drive.
Entering SETUP	BIOS Setup Utility runs.
Extended RAM Failed at offset: nnnn	Extended memory failed or configured incorrectly. Make sure SIMMs are installed correctly. If the problem persists replace the defective RAM. Run the BIOS Setup utility and restore all settings to original values.
nnnn Extended RAM Passed	Where <i>nnnn</i> is the amount of extended memory (in kilobytes) that tested successfully.
Failing Bits: nnnn	<i>nnnn</i> is a map of the bits at the RAM address which failed the memory test. Run the BIOS Setup Utility and restore all settings to original values.
Fixed Disk 1 Failure Fixed Disk Controller failure	Run the BIOS Setup Utility. Check all connections. If the problem persists.
Incorrect Drive A type - run SETUP	Diskette drive A and/or B not correctly identified in the BIOS Setup utility.
Incorrect Drive B type - run SETUP	Run the BIOS Setup Utility and properly identify diskette drive A and/or B.
Invalid NVRAM media type	NVRAM access failed. Run the BIOS Setup Utility and restore all settings to original values. If the problem persists replace the defective component.
Keyboard controller error Keyboard error Keyboard locked - Unlock key switch	Check the keyboard connection. If the connection is secure the keyboard or keyboard controller might have failed. If the problem persists replace the defective component.
Monitor type does not match CMOS - Run SETUP	Run the BIOS Setup utility and set the correct monitor type.
Operating system not found	The operating system cannot be found on drive A or drive C. Run the BIOS Setup Utility and correctly identify drive A or drive C. Correctly install the operating system. Refer to the supplied operating system documentation.
Parity check 1 nnnn	Parity error found in the computer bus. The BIOS attempts to locate the address and display it on the monitor screen.
Parity check 2 nnnn	Run the BIOS Setup Utility and restore all settings to original values. If the problem persists replace the defective component.
Press <F1> to resume, <F2> to Setup	This message appears after any recoverable error message. Press <F1> to reboot or <F2> to enter the BIOS Setup utility to make any necessary changes.
Real time clock error	Real-time clock failed BIOS test. Replace the battery and then run the BIOS Setup Utility to restore previous configuration information.
Shadow RAM Failed at offset: nnnn	Shadow RAM failed. Run the BIOS Setup Utility and disable failed shadow memory region.

POST and Boot Messages (continued)

nnnn Shadow RAM passed	Where <i>nnnn</i> is the amount of shadow RAM (in kilobytes) that tested successfully.
System battery is dead Replace and run SETUP	Replace the battery and then run the BIOS Setup utility to restore previous configuration information.
System BIOS shadowed	This indicates that the computers BIOS was successfully copied to shadow RAM.
System cache error - Cache disabled	RAM cache failed. Run the BIOS Setup Utility and restore all settings to original values. If the problem persists replace the defective component.
System CMOS checksum bad - run SETUP	Run the BIOS Setup Utility and ensure that all settings are correct. Save the configuration even if no changes have been made. If the problem persists replace the defective component.
System RAM failed at offset: nnnn	System RAM failed. Run the BIOS Setup Utility and restore all settings to original values. If the problem persists replace the defective component.
nnnn System RAM passed	Where <i>nnnn</i> is the amount of system RAM (in kilobytes) that tested successfully.
System timer error	The computers timer test failed. Run the BIOS Setup Utility and restore all settings to original values. If the problem persists replace the defective component.
UMB upper limit segment address: nnnn	Displays the address of the upper limit of UMB. This indicates the released segments of the BIOS that can be reclaimed by a virtual memory manager.
Video BIOS shadowed	This indicates that the computers video BIOS was successfully copied to shadow RAM.

Computer Troubleshooting

Problem	Possible Cause	Action
No response when the computer is turned on	Main logic board failure.	Replace main logic board.
	Main logic board jumpers incorrectly set.	Set all appropriate jumpers. Refer to “ <i>Main logic board jumpers</i> ”.
	CPU has failed.	Replace CPU.
Computer operates incorrectly after installing optional SIMMs	Did not rerun BIOS Setup utility.	Rerun BIOS Setup utility.
	BIOS Setup utility changes not saved before exiting.	Rerun BIOS Setup utility and save changes.
	SIMMs have failed.	Remove SIMMs and reinstall Make sure banks 1 and 2 are filled with the correct SIMM size, speed and type. Replace SIMMs.

Computer Troubleshooting (continued)

Problem	Possible Cause	Action
Power is on, but there is no screen display	<p>Brightness and contrast controls are not correctly set.</p> <p>The monitor-off timer has shut the monitor off.</p> <p>Monitor cable is incorrectly installed.</p> <p>Incorrect VGA drivers installed.</p> <p>Video controller has failed.</p>	<p>Adjust the brightness and contrast controls.</p> <p>Press [Shift] to reactivate monitor.</p> <p>Check all monitor connections.</p> <p>Install the correct VGA drivers. Refer to <i>“Utilities & Video Drivers”</i>.</p> <p>Replace the video controller.</p>
Computer operates incorrectly after installing optional expansion board	<p>Expansion board installed incorrectly.</p> <p>Did not run ICU to configure expansion board before installation.</p> <p>Expansion board has failed.</p>	<p>Remove expansion board and reinstall.</p> <p>Run the ICU to properly configure expansion board and then reboot the computer. Refer to the supplied ICU documentation.</p> <p>Remove expansion board and reboot. If computer boots without errors, replace expansion board.</p>
Computer operates incorrectly after installing optional external cache module	<p>External cache module installed incorrectly.</p> <p>External cache module has failed.</p>	<p>Remove external cache module and reinstall.</p> <p>Replace external cache module.</p>
Computer fails to retain setup information	<p>Computer battery has failed.</p>	<p>Replace computer battery.</p>
Computer does not boot from an internal SCSI hard disk drive	<p>Operating system software is not installed on the SCSI hard disk drive.</p> <p>Requested partition does not exist.</p> <p>Computer not configured for SCSI hard disk drive operation.</p>	<p>Install the appropriate operating system on the SCSI hard disk drive.</p> <p>Partition the SCSI hard disk drive and then reload the operating software.</p> <p>Run the BIOS Setup utility and set the IDE controller option to “Disabled”. This disables the IDE interface.</p> <p>Note: When both IDE and SCSI hard disk drives have been installed, the computer uses the IDE hard disk drive as the boot device.</p>

Computer Troubleshooting (continued)

Problem	Possible Cause	Action
No response to keyboard commands	Keyboard is password protected.	Enter the keyboard password.
	Keyboard is connected to the mouse port.	Power down the computer and connect the keyboard to the keyboard port.
No response to mouse commands	Mouse is password protected.	Enter the keyboard and mouse password.
	Mouse is connected to the keyboard port.	Power down the computer and connect the mouse to the mouse port.
	Mouse driver not installed.	Install the appropriate mouse driver.
Computer does not recognize an internal or external SCSI device	SCSI device jumpers incorrectly set.	Refer to the supplied SCSI device kit installation instructions.
	SCSI cable not terminated.	Terminate each end of the SCSI bus. Check power and SCSI cables.
	Terminating resistors not removed from the SCSI device.	Remove terminating resistors.
	SCSI adapter failure.	Replace SCSI adapter.
	SCSI ID conflicts.	Set SCSI IDs correct.
	There might be a boot sector virus.	Run appropriate software to detect and remove viruses.
	Hard disk boot sector is missing.	For DOS, boot from a DOS diskette then enter the following commands: c: cd\dos fdisk/mbr

Computer Troubleshooting (continued)

Problem	Possible Cause	Action
Computer does not boot from an IDE hard disk drive	Operating system software is not installed on the IDE hard disk drive.	Install the appropriate operating system.
	IDE hard disk drive is not correctly formatted or the requested partition does not exist.	Format the IDE hard disk drive or partition the IDE hard disk drive using the supplied operating system software.
	There is no software on the requested partition.	Install software on the requested partition.
	IDE hard disk drive jumpers incorrectly set.	Refer to the supplied IDE hard disk drive kit installation instructions.
	IDE drive type incorrect.	Run the BIOS Setup utility to identify the correct drive type.
	Loose cables.	Secure all cable connections.
	Onboard IDE interface disabled.	Run the BIOS Setup utility and set the IDE controller option to "Enabled".
	IDE hard disk is connected to the wrong IDE connector.	Connect the boot disk to the inner IDE connector on the main logic board.
	There might be a boot sector virus.	Run appropriate software to detect and remove viruses (F-PROT recommended).
Hard disk boot sector is missing.	For DOS, boot from a DOS diskette then enter the following commands: c: cd\dos fdisk/mbr	
Computer does not boot from a target diskette drive	Drive ID incorrectly set.	Make sure the drive ID is correctly set.
	Diskette drive not enabled.	Run the BIOS Setup utility to enable the diskette drive.
	Diskette boot option disabled.	Run the BIOS Setup utility and set the proper boot sequence.
	Onboard diskette controller disabled.	Run the BIOS Setup utility and set the diskette controller option to "Enabled".
Diskette does not contain start-up files.	Insert a diskette with the correct start-up files.	

Disk Drive Troubleshooting

Problem	Possible Cause	Action
IDE/SCSI hard disk drive cannot read or write information	Incorrect disk drive jumper settings.	Refer to the supplied kit installation instructions.
	Loose or incorrectly installed cables.	Make sure all cables are correctly installed.
	IDE drive type incorrect.	Run the BIOS Setup utility to identify the correct drive type.
	Onboard IDE interface disabled.	Run the BIOS Setup utility and set the IDE controller option to "Enabled".
	IDE/SCSI hard disk drive is not correctly formatted or partitioned.	Format and partition as required using the supplied operating system.
Target diskette drive cannot read or write information	Onboard diskette controller disabled.	Run the BIOS Setup utility and set the diskette controller to "Enabled".
	Diskette write protection is enabled.	Run the BIOS Setup utility and set the diskette write protection to "Disabled".

Monitor Troubleshooting

Problem	Possible Cause	Action
Monitor power indicator is not on	Monitor is turned off.	Turn on the monitor.
	Power indicator is defective.	Replace the failed component.
No screen display	Configuration error.	Run the BIOS SETUP UTILITY to configure the computer for VGA operation. Set the jumper for VGA operation. Refer to "Main Logic Board Jumpers".
	Monitor brightness and contrast controls are incorrectly set.	Adjust the monitor brightness and contrast controls.
No monitor display while loading Windows video drivers	Monitor type incorrectly set.	Set the correct monitor type. Refer to appropriate video driver documentation.

Monitor Troubleshooting (continued)

Problem	Possible Cause	Action
Distorted-rolling-or flickering screen display-or wrong/uneven color	Monitor incorrectly adjusted.	Adjust accordingly.
	Monitor signal cable incorrectly installed.	Straighten any bent connector pins and then reconnect.
Color monitor displaying monochrome	Computer was turned on before the monitor was turned on.	Turn off the computer, turn on the monitor, then turn the computer back on.
	Video jumper incorrectly set.	Set the jumper for VGA operation.
Monitor fails to switch to high-resolution mode	Appropriate high-resolution video drivers are not installed or incorrectly installed.	Correctly install all appropriate high-resolution video drivers. Refer to the documentation supplied with the monitor and/or video drivers.
Monitor display not centered while loading Windows video drivers	Monitor type incorrectly set.	Set the correct monitor type. Refer to appropriate video driver documentation.

QAPIus/FE Error Messages

Component	Messages	Solution
CPU	Arithmetic Function Failed. General Functions Failed. Exception Interrupt in Protected Mode. Refresh Failure. Logic Functions Failed.	Reset CPU. Replace CPU.
Hard disk	Butterfly Cylinder Access Test Failed. Cylinder 0 Errors. Random Cylinder Access Failed. Linear Cylinder Access Failed.	Low-level format hard disk. Replace disk.
Hard drive/controller	Controller Diagnostic Test Failed. Questionable Controller Card. Hard drives failed.	Run Setup, Check connections, Reset controller, Replace controller, Replace disk.
Floppy diskette	Media Mismatch. Drive Not Ready. Write Protected Media. Unformatted Media.	Use known good diskette. Check size and density of diskette. Close drive door. Remove write protection. Format diskette.

QAPLUS/FE Error Messages (continued)

Component	Messages	Solution
Floppy drive	Floppy Drives Failed.	Check connections, Replace drive.
Battery/clock	Clock Stopped. Invalid Date. RTC Interrupt Failed.	Run Setup. Replace battery/clock.
CMOS	CMOS Clock Test Failed.	Change time from Setup menu in QAPLUS.
Serial port	COM port failed. Serial Chip Error. Serial Compare Error. Serial Timeout Error.	Check COM device. Check connections. Replace COM device. Replace COM device.
Video adapter	Video Failed. Error in Video Buffer.	Replace video adapter. Replace video adapter.

Chapter 5

Device Mapping

This section provides a series of tables listing mapping and address information related to computer memory and various main logic board devices (keyboard controller, interrupt controller, DMA controller, etc.).

The computer's memory and address locations are allocated at the factory to operate within a standard PC environment. However, due to the number of optional devices and/or expansion boards that are available, sometimes memory and address locations need to be changed. For example, some network expansion boards require a specific memory location. If that location is already allocated, a memory conflict results and the expansion board will not operate as expected. Note that some memory, I/O and interrupt locations can be changed using the BIOS Setup utility.



CAUTION

Before changing any memory or address location, refer to the documentation supplied with the optional device, expansion board or software application and make sure adequate information is available.

CPU Memory Address Map (Full Range)

<i>Range</i>	<i>Function</i>	<i>Notes</i>
0 KB to 640 KB	Main memory	PC compatibility range
640 KB to 1024 KB	Main memory	PC compatibility range (ISA memory lower limit)
1 MB to 16 MB	Main memory Memory space gap	ISA memory upper limit
16 MB to 128 MB	Main memory	Computer memory upper limit

I/O Address Map

Range (hexadecimal)	Function
000 - 00F	DMA controller one
020 - 021	Interrupt controller one
040 - 043	Interval timer
060 - 06F	Keyboard controller
070 - 07F	Real-time clock (RTC), NMI
080 - 08F	DMA page register
0A0 - 0A1	Interrupt controller two
0C0 - 0CF	DMA controller two
0F0	Clear math coprocessor busy
0F1	Reset math coprocessor
0F8 - 0FF	Math coprocessor
170 - 177	Secondary IDE controller
1F0 - 1F7	Primary IDE controller
278 - 27A	LPT2
2E8 - 2EF	COM4
2F8 - 2FF	COM2
376 - 377	Secondary IDE controller (alt status, device address)
378 - 37A	LPT1
3B0 - 3DF	VGA register
3BC - 3BE	LPT3
3E8 - 3EF	COM3
3F0 - 3F7	Diskette controller
3F6 - 3F7	Primary IDE controller (alt status, device address)
3F8 - 3FF	COM1
46E8	VGA enable register
42E8, 4AE8, 82E8, 86E8, 8AE8, 8EE8, 92E8, 96E8, 9AE8, 9EE8, A2E8, A6E8, AAE8, AEE8, B2E8, B6E8, BAE8, BEE8, E2E8, E2EA	VGA enhanced mode registers

Computer Interrupt Levels

<i>Interrupt Number</i>	<i>Interrupt Source</i>
IRQ0	Timer tick
IRQ1	Keyboard controller
IRQ2	Cascade interrupt
IRQ3	COM2, COM4 (if enabled)
IRQ4	COM1, COM3 (if enabled)
IRQ5	LPT2
IRQ6	Diskette drive (if enabled)
IRQ7	LPT1, LPT3 (if enabled)
IRQ8	RTC
IRQ9-IRQ11	Reserved
IRQ12	Mouse interrupt (if enabled)
IRQ13	Math co-processor
IRQ14	IDE adapter 0 (if enabled)
IRQ15	IDE adapter 1 (if enabled)

DMA Channel Assignment

<i>Channel</i>	<i>Controller</i>	<i>Function</i>
0	1	Refresh
1	1	Not used
2	1	Diskette (floppy disk) controller, if enabled
3	1	ECP
4	2	Cascade DMA
5	2	Not used
6	2	Not used
7	2	Not used

Chapter 6

Pass / Fail Criteria

As Final Acceptance Test the following tests should be run to meet the Pass/Fail criteria:

- 1) **Successful completion of the POST tests.**
- 2) **Successful completion of the following QAPLUS/fe module tests (one pass):**
 - ◆ System Board (all tests)
 - ◆ Memory (all tests)
 - ◆ Video (all tests)
 - ◆ Hard Disk (all tests, **except: Sequential write/read (destructive test !!) and Sequential write/random read (destructive test !!)**)
 - ◆ Floppy Disk (all tests)
 - ◆ Keyboard (all tests)
 - ◆ COM Ports (all tests)
 - ◆ LPT Ports (all tests)
 - ◆ Pointer Device (all tests)
- 3) **Successful bootstrap of the on the computer installed Operating System.**

Operating Systems Supported:

 - ◇ MS-DOS version 6.22 and earlier
 - ◇ Windows 3.1 / Windows for Workgroups 3.11
 - ◇ OS/2 3.0 WARP
 - ◇ Windows NT Workstation
 - ◇ Windows 95
 - ◇ SCO UNIX System V release 3.2.4, client only
 - ◇ Novell Netware 3.13 and 4.0, client only
 - ◇ NeXTSTEP, Bayyan Vines 5.5, client only
 - ◇ Microsoft LAN Manager, IBM LAN Manager

Remove any software that was put on the hard drive to enable repair of the system before shipping.

When completed, carefully clean the outside of the unit with cleaning solution.

Appendix A

Service Notes

This appendix contains the current Service Notes for the VENTURIS Pentium product line.

Symptom: System does not boot.

Problem: Riser card (3 or 5 slot) presses main board to hard; the result is a short circuit to the metal chassis.

Solution: Dismantle enclosure and remount riser card carefully.

Appendix B

Useful Information

Related Documentation

Document Titles	Order's
VENTURIS Pentium PC family Quick Reference Guide	EK-A0831-RG
Service Maintenance Manual Spares Catalogue	EK-A0815-RG
VENTURIS 560 User's Guide (English)	ER-856WW-UA
VENTURIS 560 User's Guide (French)	ER-856WW-UP
VENTURIS 560 User's Guide (Italian)	ER-856WW-UI
VENTURIS 560 User's Guide (German)	ER-856WW-UG
VENTURIS 560 User's Guide (Spanish)	ER-856WW-US
VENTURIS 575 & FP575 User's Guide (English)	ER-920WW-UA
VENTURIS 575 & FP575 User's Guide (French)	ER-920WW-UP
VENTURIS 575 & FP575 User's Guide (Italian)	ER-920WW-UI
VENTURIS 575 & FP575 User's Guide (German)	ER-920WW-UG
VENTURIS 575 & FP575 User's Guide (Spanish)	ER-920WW-US
VENTURIS 575 & FP575 User's Guide (Japanese)	ER-920WW-UJ

On-Line Bulletin Boards

The most current product information and technical support is also available on line. The most current device drivers, Setup diskettes and technical tips can be found on all of these bulletin boards.

◆ **DECpc Bulletin Board Server**

DECpc BBS provides an easy-to-use, menu-driven bulletin board providing on-line access to the latest PC product information, device drivers, shareware and freeware.

Network Location for ;

North America, South America, Australia and New Zealand
PCBUHD::DKB300:[WC30.BBSFILES]

Europe, Africa, Middle and Far East:
SUTRA::D6:[PUBLIC].

Document Feedback

If you have comments on the contents or layout of this document we highly appreciate your feedback. We will do our best to make this document a valuable support to your service efforts for Digital. Please fill-out the reader feedback form and send or fax it to:

Digital Equipment Parts Center b.v.
Att: MCS Logistics Engineering Call Desk
P.O. Box 6774
6503 GG Nijmegen
Holland

If you have questions about this document please do not hesitate to get in contact with our Call Desk. The number is:

Phone: xx31-24-3529666

Fax: xx31-24-3563106

READERS COMMENTS

Digital VENTURIS Pentium Service Maintenance Manual K-MN-SD00000-06-JG00.B

This form is for documents only. Commitments submitted on this form are used at Digital's direction.

Did you find errors in this manual? If so, specify by page.

.....
.....
.....

What is your general reaction to this manual (format, completeness, organization, etc.)?

.....
.....
.....

Is the documentation understandable, usable and sufficient for your needs? What material is missing?

.....
.....
.....

Additional comments:

.....
.....
.....
.....

Name

Title

Company Dept.

Address

City State

Country