

Venturis FX and Celebris FX

System Reference

Part Number: ER-BAAWW-UA. A01

Digital Equipment Corporation

July 1996

The information in this document is subject to change without notice and should not be construed as a commitment by Digital Equipment Corporation.

Digital Equipment Corporation assumes no responsibility for any errors that might appear in this document.

The software described in this document is furnished under a license and may be used or copied only in accordance with the terms of such license. No responsibility is assumed for the use or reliability of software or equipment that is not supplied by Digital Equipment Corporation or its affiliated companies.

Restricted Rights: Use, duplication, or disclosure by the U.S. Government is subject to restrictions as set forth in subparagraph (c) (1) (ii) of the Rights in Technical Data and Computer Software clause at DFARS 252.227-7013.

Venturis FX and Celebris FX System Reference

Copyright© Digital Equipment Corporation.

All Rights Reserved.

DEC, Celebris, Venturis, and the Digital logo are registered trademarks of Digital Equipment Corporation

Intel is a registered trademark of Intel Corporation.

Pentium is a registered trademark of Intel Corporation

Microsoft, Windows 95, and Windows NT are registered trademarks of Microsoft Corporation.

SIMM is a registered trademark of Wang Laboratories.

All other trademarks and registered trademarks are the property of their respective holders.

The FCC wants you to know...

This equipment has been tested and found to comply with the limits for a Class B digital device, pursuant to Part 15 of the FCC rules. These limits are designed to provide reasonable protection against harmful interference in a residential installation.

Any changes or modifications made to this equipment may void the user's authority to operate this equipment.

This equipment generates, uses, and can radiate radio frequency energy and, if not installed and used in accordance with the instructions, may cause harmful interference to radio communications. However, there is no guarantee that interference will not occur in a particular installation. If this equipment does cause harmful interference to radio or television reception, which can be determined by turning the equipment off and on, the user is encouraged to try to correct the interference by one or more of the following measures:

- Reorient or relocate the receiving antenna
- Increase the separation between the equipment and receiver
- Connect the equipment into an outlet on a circuit different from that to which the receiver is connected
- Consult the dealer or an experienced radio/TV technician for help

The user may find the following booklet prepared by the Federal Communications Commission helpful: How to Identify and Resolve Radio-TV Interference Problems. This booklet is available from the U.S. Government Printing Office, Washington, D.C., 20402. Stock No. 004-00398-5.

All external cables connecting to this basic unit need to be shielded. For cables connecting to option boards, see the option manual or installation instructions.

This digital apparatus does not exceed the Class B limits for radio noise emissions set out in the radio interference regulations of the Canadian Department of Communications.

This equipment is in the 2nd Class category (information equipment to be used in a residential area or an adjacent area thereto) and conforms to the standards set by the Voluntary Control Council For Interference by Data Processing Equipment and Electronic Office Machines aimed at preventing radio interference in such residential area.

When used near a radio or TV receiver, it may become the cause of radio interference.

Read the instructions for correct handling.

This equipment meets or exceeds requirements for safety in the U.S. (UL 1950), Canada (CSA C22.2 No. 950), and Europe (EN 60950/IEC 950) with Nordic requirements.

This equipment meets or exceeds the ergonomic requirements of ZH1/618 and is certified to bear the GS mark by TUV Rheinland of Germany.



WARNING: There is a danger of battery explosion if a lithium battery is incorrectly replaced. To prevent damage to your computer, be sure the + side faces up when installing a new battery. Also, be sure you replace the battery with either a Digital (P/N 12-41474-05), Toshiba (P/N CR2032), or equivalent 3 V dc lithium battery.

Depending on your locality, your computer's battery might be considered hazardous waste. Make sure you follow any state or local statute to properly dispose of the old battery.



ADVARSEL: Der er fare for, at et lithiumbatteri eksploderer, hvis det udskiftes ukorrekt. Undgå, at beskadige din computer - HUSK, at + siden skal vende opad, når du installerer et nyt batteri. Du skal udskifte batteriet med enten et Digital (delnummer 12-41474-05), Toshiba (delnummer CR2032), eller tilsvarende 3 V jævnstrøms lithiumbatteri.

Afhængig af dit lokalområde, er det muligt, at din computers batteri betragtes som farligt affald. Husk, at følge evt. miljølove og lokale bestemmelser, når du kasserer det gamle batteri.



VAROITUS: Litiumpatterit voivat räjähtää, jos ne asennetaan väärin. Estääksesi tietokoneesi vaurioitumisen varmista, että patteria asentaessasi sen positiivinen (+) puoli on ylöspäin. Tarkista myös, että käyttämäsi uusi patteri on joko Digital (osa no. 12-41474-05), Toshiba (osa no. CR2032) tai vastaavanlainen 3 voltin tasavirtalitiumpatteri.

Asuinpaikastasi riippuen tietokoneesi patteria voidaan pitää ongelmajätteenä. Pidä huoli, että hävität vanhan patterin voimassa olevien lakien ja asetusten mukaisesti.



WARNING! Det kan förekomma en batteriexplosion om ett litium-jonbatteri byts ut på felaktigt sätt. Förhindra att datorn skadas genom att se till att plussidan (+) är uppåtvänd när du sätter i ett nytt batteri. Det gamla batteriet får endast bytas ut mot ett Digital-batteri (artikelnummer 12-41454-05), ett Toshiba-batteri (artikelnummer CR2032) eller ett motsvarande litiumbatteri på 3 volt likström.

Datorbatterier anses vara miljöfarligt avfall i många länder. Du måste följa alla lokala bestämmelser när du avyttrar ett gammalt batteri.

Contents

Preface

Introduction	vii
Related Material	vii
Latest Product Information and Updates	viii
Venturis FX and Celebris FX Computers	viii
Chassis Versions	viii
Models	xi
Audience	xi
Organization	xi
Energy Star Compliant	xiii
Conventions	xiii
Special Notices	xiv

1

Beyond Quick Setup

Introduction	1-1
Front Panel Controls and Indicators	1-2
Rear Panel Connectors and Voltage Select Switch	1-4
Typical CD-ROM Front Panel (Yours Might Differ from the One Shown)	1-6
Removing your Computer's Outside Cover	1-8
Replacing your Computer's Outside Cover	1-10
Chassis Lockdown	1-12
Attaching the Hasp (Venturis FX and Celebris FX Low Profile)	1-13
Attaching the Hasp (Venturis FX Short Tower Computers)	1-14
Connecting Speakers (Venturis FXsm Only)	1-15
Connecting Headphones (Venturis FXsm Only)	1-16
Connecting a Microphone (Venturis FXsm Only)	1-17
Connecting a Local Printer	1-18

Contents

Connecting a Universal Serial Bus (USB) Device.....	1-20
Connecting a MIDI/Joystick Device (Venturis FXsm Only).....	1-22
Your Computer's Windows Enhanced Keyboard	1-23
Creating a Comfortable Working Environment.....	1-24

2

Using the BIOS Setup Utility

What is the BIOS Setup Utility?	2-1
Accessing the BIOS Setup Utility	2-2
Helpful Hints	2-2
Changing Your Computer's Configuration.....	2-4
Changing Time and Date	2-4
Setting Up Security	2-4
Setting Supervisor and User Passwords	2-4
Enabling Password On Boot.....	2-6
Eliminating User and Supervisor Passwords	2-7
Protecting Against Boot Sector Viruses	2-8
Other Security Options	2-9
Setting Power Management Options.....	2-10
Setting up Power Management.....	2-10
Putting Your Computer Quickly into Full Power Management	2-11
Configuring for New Disk Drives	2-12
Diskette Drive Configuration.....	2-12
Hard Disk Drive Configuration.....	2-13
Autotyping a Hard Disk	2-13
Manually Defining a Hard Disk	2-14
Changing the Boot Sequence.....	2-15
Speeding up the Boot Process	2-16
Resetting Keyboard Features	2-17
Changing the Keyboard Features	2-18
Setting Your Computer's Volume Control	2-19
Flash Utility.....	2-19

3

Inside Your Computer

Introduction	3-1
Preparing Your Computer for Expansion	3-2
Your Computer's Components and Connectors.....	3-2

Computer Components	3-2
Main Logic Board Components	3-4
Main Logic Board Connectors (Rear Panel)	3-6
Main Logic Board Connectors	3-8
Venturis FX Low Profile Backplane Components and Connectors	3-10
Celebris FX Low Profile Backplane Components and Connectors	3-12
Venturis FX Short Tower Backplane Components and Connectors	3-14
Celebris FX Network Adapter Card Connector	3-16
Audio Adapter Card Connections (Venturis FXsm Only)	3-17
Removing the Main Logic Board (Venturis FX Short Tower Only)	3-18
Replacing the Main Logic Board (Venturis FX Short Tower Only)	3-18
Replacing the Lithium Battery	3-20
Installing a Higher Performance Processor	3-23
Installing a Processor VRM	3-25

4

Main Logic Board Expansion

Introduction	4-1
Installing Additional Computer Memory	4-1
Memory Configurations	4-4
Installing a SIMM	4-7
Installing a Secondary Cache Module	4-9
Installing Video Memory	4-11
Installing an Optional WaveTable Daughter Card (Venturis FXsm Only)	4-13

5

Adding Expansion Boards

Introduction	5-1
Configuring Expansion Slots	5-1
Expansion Slots (Venturis FX and Celebris FX Low Profile)	5-2
Expansion Slots (Venturis FX Short Tower)	5-4
Installing Expansion Boards	5-6
Removing Expansion Boards	5-10

6

Adding Mass Storage Devices

Introduction	6-1
Installing Mass Storage Devices (Venturis FX and Celebris FX Low Profile)	6-1
Installing Mass Storage Devices (Venturis FX Short Tower)	6-2
Installing a 3½-Inch Device into the Bottom-Right Device Bay (Venturis FX and Celebris FX Low Profile)	6-2
Installing a 5¼-Inch Device into the Bottom-Right Device Bay (Venturis FX and Celebris FX Low Profile)	6-5
Installing a 3½-Inch Device into a Front Device Bay (Venturis FX Short Tower)	6-7
Installing a 5¼-Inch Device Into a Front Device Bay (Venturis FX Short Tower)	6-10
Installing a 3½-Inch Device into the Internal Device Bay (Venturis FX Short Tower)	6-12
Connecting Diskette and IDE Devices (Venturis FX and Celebris FX Low Profile)	6-15
Connecting Diskette and IDE Devices (Venturis FX Short Tower)	6-20

A

Technical Specifications

Introduction	A-1
Computer Specifications	A-2
Features	A-2
Performance Specifications	A-2
Computer Dimensions (Venturis FX and Celebris FX Low Profile)	A-3
Computer Dimensions (Venturis FX Short Tower)	A-3
Environmental Specifications	A-4
ISA Expansion Slots	A-4
PCI Local Bus Expansion Slots	A-5
Venturis FX and Celebris FX Low Profile System Input Power Requirements	A-5
Venturis FX Short Tower System Input Power Requirements	A-5
Power Supply Requirements	A-5
Current Requirements	A-6
Venturis FX and Celebris FX Low Profile (100 W)	A-6
Venturis FX Short Tower (200 W)	A-6
Power Cord Requirements	A-7

Main Logic Board Jumper Settings.....	A-8
Processor Jumper Settings.....	A-9
If You Forget Your Password.....	A-10

B

Device Mapping

Introduction	B-1
CPU Memory Address Map (Full Range)	B-2
I/O Address Map.....	B-3
Computer Interrupt Levels.....	B-5
DMA Channel Assignment.....	B-6

C

Video Output Information

Introduction	C-1
Video Resolution Modes	C-2

Figures

Typical Venturis FX and Celebris FX Low Profile Computer.....	ix
Typical Venturis FX Short Tower Computer	x
1-1. Front Panel Controls and Indicators	1-3
1-2. Rear Panel Connectors and Voltage Select Switch.....	1-5
1-3. Typical CD-ROM Front Panel.....	1-7
1-4. Removing the Outside Cover.....	1-9
1-5. Replacing the Outside Cover	1-11
1-6. Attaching the Hasp (Venturis FX and Celebris FX Low Profile)	1-13
1-7. Attaching the Hasp (Venturis FX Short Tower Computers)	1-14
1-8. Connecting Speakers (Venturis FXsm Only)	1-15
1-9. Connecting Headphones (Venturis FXsm Only).....	1-16
1-10. Connecting a Microphone (Venturis FXsm Only)	1-17
1-11. Connecting a Printer	1-19
1-12. Connecting a USB Device	1-21
1-13. Connecting a MIDI/Joystick Device (Venturis FXsm Only)	1-22
1-14. Windows Enhanced Keyboard	1-23
1-15. Creating a Comfortable Working Environment	1-26
3-1. Computer Components.....	3-3

Contents

3-2. Main Logic Board Components	3-5
3-3. Main Logic Board Components (Rear Panel)	3-7
3-4. Main Logic Board Connectors	3-9
3-5. Venturis FX Low Profile Backplane Components and Connectors.....	3-11
3-6. Celebris FX Low Profile Backplane Components and Connectors	3-13
3-7. Venturis FX Short Tower Backplane Components and Connectors	3-15
3-8. Celebris FX Network Adapter Card Connector.....	3-16
3-9. Audio Adapter Card Connections (Venturis FXsm Only).....	3-17
3-10. Removing the Main Logic Board (Venturis FX Short Tower Only)	3-19
3-11. Replacing the Battery.....	3-22
3-12. Installing a Higher Performance Processor.....	3-24
3-13. Installing a VRM.....	3-26
4-1. SIMM Socket Locations for Most Models (Some Models Have 4 SIMM Sockets).....	4-2
4-2. Installing a SIMM	4-8
4-3. Installing a Secondary Cache Module	4-10
4-4. Video Memory Installation.....	4-12
4-5. Wave Table Expansion Board Installation (Venturis FXsm Only)	4-14
5-1. Expansion Board Slots (Venturis FX and Celebris FX Low Profile).....	5-3
5-2. Expansion Board Slots (Venturis FX Short Tower)	5-5
5-3. Removing a Metal Filler Plate	5-7
5-4. Installing an Expansion Board	5-9
6-1. Installing Drive Rail and 3½-Inch Device Brackets (Venturis FX and Celebris FX Low Profile).....	6-3
6-2. Installing a 3½-Inch Device (Venturis FX and Celebris FX Low Profile).....	6-4
6-3. Installing a 5¼-Inch Device (Venturis FX and Celebris FX Low Profile).....	6-6
6-4. Removing the Front Bezel (Venturis FX Short Tower)	6-8
6-5. Installing a 3½-Inch Device (Venturis FX Short Tower)	6-9
6-6. Installing 5¼-Inch Device (Venturis FX Short Tower)	6-11
6-7. Accessing the Internal 3½-Inch Device Bay (Venturis FX Short Tower).....	6-13
6-8. Attaching a 3½-Inch Device to the Internal 3½-inch Device Bay (Venturis FX Short Tower)	6-14
6-9. Diskette Drive Data Cable Connections (Venturis FX and Celebris FX Low Profile)	6-17
6-10. IDE Drive Data Cable Connections (Venturis FX and Celebris FX Low Profile)	6-19
6-11. Diskette Device Data Cable Connections (Venturis FX Short Tower).....	6-22
6-12. IDE Device Data Cable Connections (Venturis FX Short Tower).....	6-24

Preface *P*

Introduction

This guide describes how to operate, configure, and upgrade Venturis FX and Celebris FX computers. The information presented will help to familiarize you with all aspects of your computer and provide a reference tool for questions you might have in the future.

Related Material

A *Quick Setup Guide* is available as a supplement to this *System Reference*. This guide describes how to initially setup your computer.

A *Digital PC Systems Solutions* manual is available to help you troubleshoot your computer should it fail to operate after initial setup or after installing optional devices.

A *System Software* manual provides information on the operating system, utilities, and device drivers that came with your computer. Your computer also came with a CD-ROM disk that can be used to restore your system software. Refer to the CD-INFO.TXT file on the CD-ROM disk for installation and configuration information.

A *Warranty and Service Information* booklet is supplied with your computer. This booklet provides warranty information and a listing of phone numbers for technical support.

Your factory installed software includes several README.TXT files. Digital recommends that you initially read the README file in the Digital folder or directory. Read the other Readme files that are relevant to your needs and your configuration.

Depending on the operating system that is factory installed on your computer, Windows 95 or Windows NT Workstation documentation is provided as an on-line help file and in printed form.

Latest Product Information and Updates

You can access product information and download the latest BIOS, device drivers, and software updates using the Internet at:

- <http://www.pc.digital.com>
- <http://www.pc.digital.com/~ftp>

You can also access software updates through Digital's Bulletin Board Service (BBS) by calling:

In the United States: (508) 496-8800

Venturis FX and Celebris FX Computers

A variety of Venturis FX and Celebris FX computers, using two chassis variations, are discussed in this guide. The following sections provide brief descriptions of each chassis version and model.

Chassis Versions

Two chassis versions are available in the FX series: low profile and short tower as shown in the following two figures. Note that your monitor, keyboard, and mouse might look different.

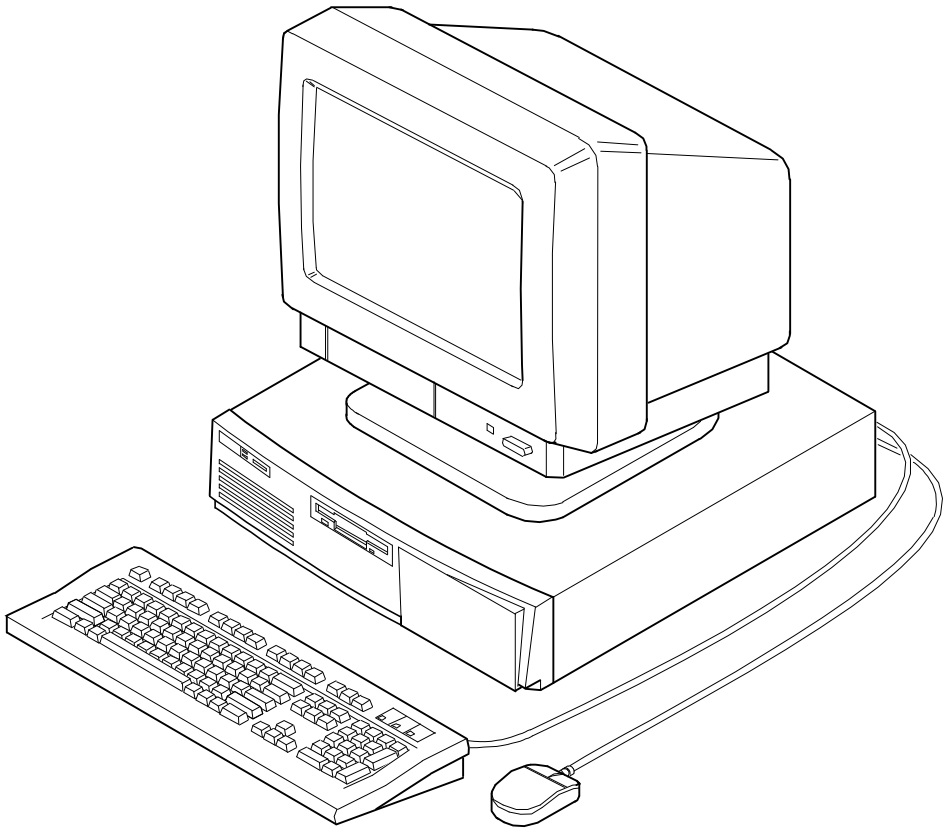

DEC00745

Typical *Venturis FX* and *Celebris FX* Low Profile Computer

Preface

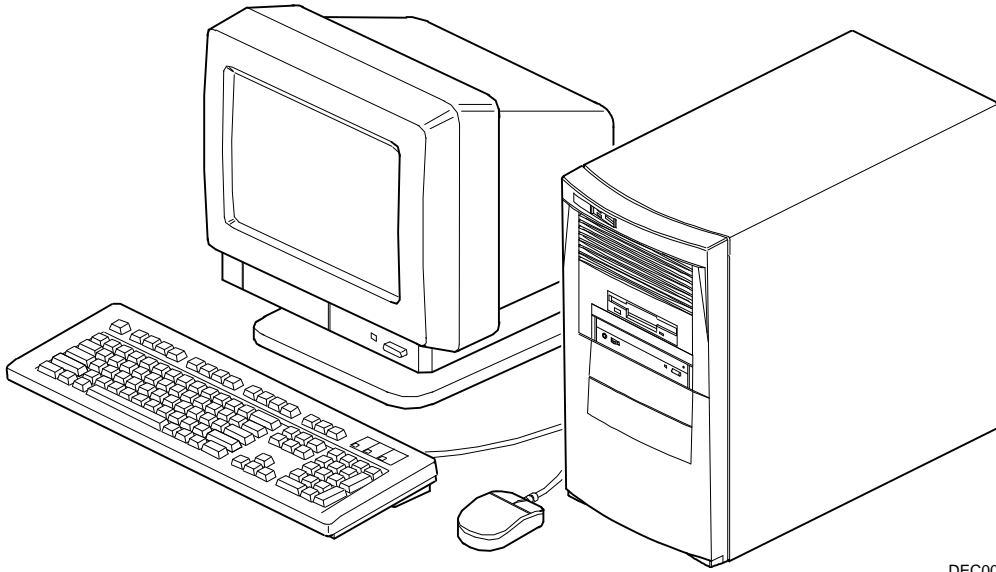

DEC00746-2

Typical *Venturis FX Short Tower Computer*

Models

The *Venturis FX* and *Celebris FX* computer models are:

- *Celebris FX*— These models are only available in the low profile version and are offered in a range of Pentium processors. They also include 256 KB external pipeline burst cache (upgradeable to 512 KB), 8 or 16 MB of EDO computer memory (upgradeable to 192 MB via six SIMM sockets), an integrated graphics accelerator with 1 MB of EDO DRAM video memory, and an integrated 32-bit PCI Ethernet controller (10Base-T ready).
- *Venturis FX*— These models are available in both the low profile and short tower versions and are offered in a range of Pentium processors. Some models include 256 KB external pipeline burst cache (upgradeable to 512 KB), 8 or 16 MB of EDO computer memory (upgradeable to 192 via six SIMM sockets), 1 MB of EDO DRAM video memory (upgradeable to 2 MB). The *Venturis FXsm* also includes onboard audio, a CD-ROM, and 2 MB of EDO video DRAM. The *Venturis FXe* includes a cache socket for upgradeability up to 512 KB, 8 or 16 MB of Fast Page memory (upgradeable to 128 MB via 4 SIMM sockets), and 1 MB of video memory.

Audience

This guide is written specifically for anyone responsible for configuring and expanding a *Venturis FX* and *Celebris FX* computer.

Organization

This guide contains the following:

- Chapter 1: *Beyond Quick Setup*— This chapter describes your computer's front and rear panel components, indicators, and connectors. This chapter also explains how to physically secure your computer to a desk or table, connect optional external devices (such as headphones, microphone, printer, etc.), use your computer's Windows enhanced keyboard, and create a comfortable working environment.

- Chapter 2: *Using the BIOS Setup Utility*—This chapter provides task-based information on how to configure your computer using the BIOS Setup utility.
- Chapter 3: *Inside Your Computer*— This chapter provides internal computer component descriptions and locations as well as how to remove the main logic board, replace the battery, and upgrade to a higher-performance processor.
- Chapter 4: *Main Logic Board Expansion*—This chapter explains how to install additional computer memory, video memory, an optional secondary cache module, and an optional WaveTable daughter card.
- Chapter 5: *Adding Expansion Boards*—This chapter explains how to install ISA and PCI expansion boards.
- Chapter 6: *Adding Mass Storage Devices*—This chapter explains how to install and connect optional mass storage devices.
- Appendix A: *Technical Specifications*—This appendix lists vital computer operating and performance specifications. Also included is information about your computer's jumper settings.
- Appendix B: *Device Mapping*—This appendix contains tables listing the main logic board's memory map, I/O address map, interrupt map, and DMA map.
- Appendix C: *Video Output Information*—This appendix describes the video modes supported by your Venturis FX and Celebris FX computer's video circuitry.

Energy Star Compliant

Your Venturis FX and Celebris FX series of computers are ENERGY STAR compliant when used with Windows 95. Digital advises that you do not use the enable Power Management features with operating systems that do not allow for power management, such as SCO UNIX, Windows NT, or OS/2.

To ensure that your entire computer system remains ENERGY STAR compliant, you must use an ENERGY STAR compliant monitor, that is, a monitor that supports the DPMS protocol.

Conventions

Convention Example	Description
<i>Quick Setup</i>	Italics are typically used for titles, comments, and references to other sections of this document or other documents.
<code>c:\windows></code>	Monospaced text indicates information that your computer or software displays. For example, a directory path or error message.
<code>SCU.BAT</code>	Monospaced text can also indicate a command that you need to enter to run an application or utility.
[Enter]	Square brackets surrounding text represents a keyboard key.
[Ctrl]+[Alt]+[Del]	A plus sign indicates that the keys shown should be pressed at the same time.

Special Notices

Three kinds of special notices are used in this *System Reference* guide to emphasize specific information.



WARNING: indicates the presence of a hazard that can cause personal injury if the hazard is not avoided.



CAUTION: indicates the presence of a hazard that might cause damage to hardware or that might corrupt software.



NOTES: are used to provide additional information.

Beyond Quick Setup

1

Introduction

This chapter describes your computer's front and rear panel components, indicators, and connectors. This chapter also explains how to physically secure your computer to a desk or table, connect optional external devices (such as headphones, microphone, printer, etc.), use your computer's Windows enhanced keyboard, and create a comfortable working environment.

Front Panel Controls and Indicators

Figure Legend	Control or Indicator	Function
A	On/off switch	Turns your computer's power on and off.
B	Power LED	Lights when your computer is turned on.
C	Reset switch ⁽¹⁾	Resets your computer and causes POST to run.
D	CD-ROM drive	Available with the Venturis FXsm model and some Celebris FX models. Also available as an option on other Venturis FX and Celebris FX models.
E	Hard disk drive LED	Lights when your hard disk drive is in use.
F	Diskette activity LED	Lights when the diskette drive is in use.
G	Diskette eject button	Releases a 3½-inch diskette from the diskette drive.
H	Drive bay(s)	Enables you to add additional mass storage device(s) to your computer.
I	Microphone jack	Available only on multimedia computers, such as the Venturis FXsm.
J	Headphone jack	Available only on multimedia computers, such as the Venturis FXsm.

⁽¹⁾ Digital designed the reset button so it does not protrude significantly from the front bezel. This design prevents accidentally resetting the computer. To reset your computer, use a device such as a pen or pencil to push the reset button.

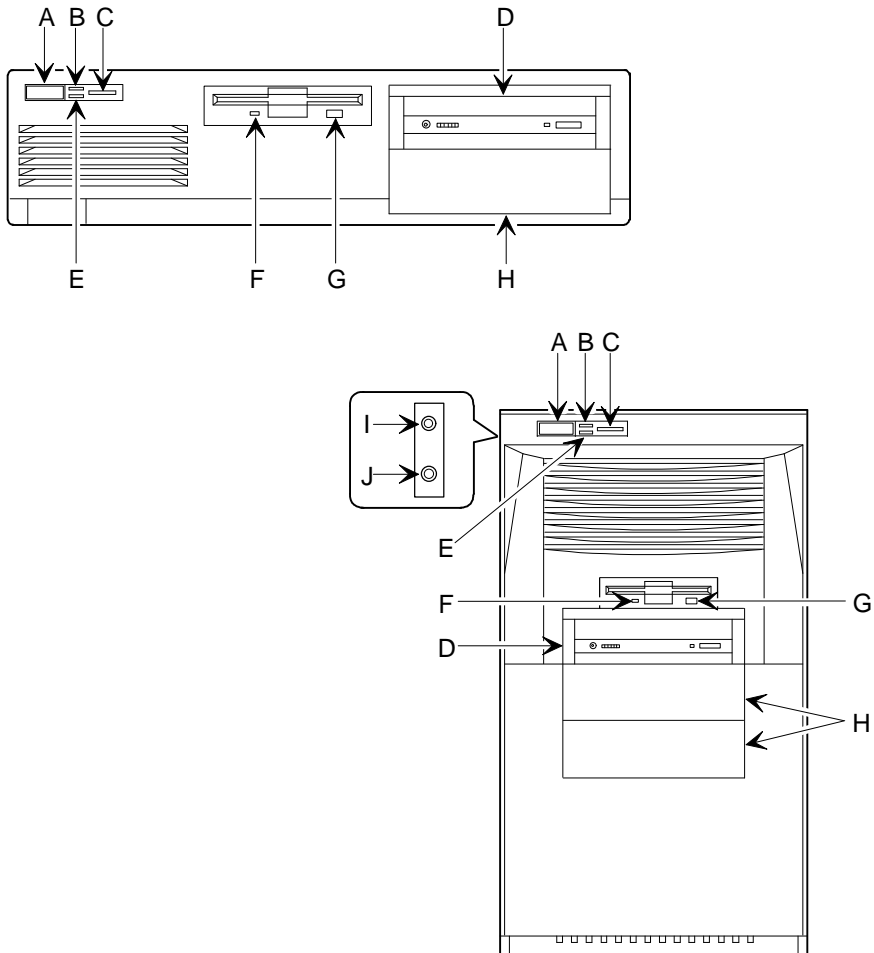

DEC00913-3

Figure 1-1. Front Panel Controls and Indicators

Rear Panel Connectors and Voltage Select Switch

Figure Legend	Connector or Switch	Function
A	Voltage select switch	Enables you to select 115 V ac input power or 230 V ac input power.
B	10Base-T port connector (phone jack)	Enables you to connect to a 10Base-T (Twisted-Pair) network (Celebris FX only).
C	Chassis lockdown	Enables you to physically anchor your computer to a fixed location.
D	Expansion board slots	Enables you to install additional ISA and PCI expansion boards.
E	ac line connector	Enables you to connect your computer to an ac power source.
F	Parallel port connector	Enables you to connect a standard, Enhanced Parallel Port (EPP), or Enhanced Capabilities Port (ECP) parallel printer.
G	Keyboard connector	Enables you to connect a 104-key keyboard.
H	Mouse connector	Enables you to connect a PS/2 style mouse.
I	Video port connector (VGA)	Enables you to connect a high-resolution monitor to your computer.
J	USB ports	Enables you to connect Universal Serial Bus (USB) devices. These ports might not be available on your computer.
K	Serial port connectors ⁽¹⁾	Enables you to connect serial devices.
L	Line out	This jack, which is only available on the Venturis FXsm, enables you to connect an external audio source to the onboard sound system. If you purchase optional external speakers, use this jack to plug the appropriate speaker cable into your computer.
M	Line in	This jack, which is only available on the Venturis FXsm, enables you to connect the audio output from your onboard sound system to an external audio device.
N	MIDI/joystick connector	Enables you to connect a MIDI/joystick device to your computer (Venturis FXsm only).

⁽¹⁾ COM1 is the top connector for low profile models and the left connector for short tower models. COM2 is the bottom connector for low profile models and the right connector for short tower models.

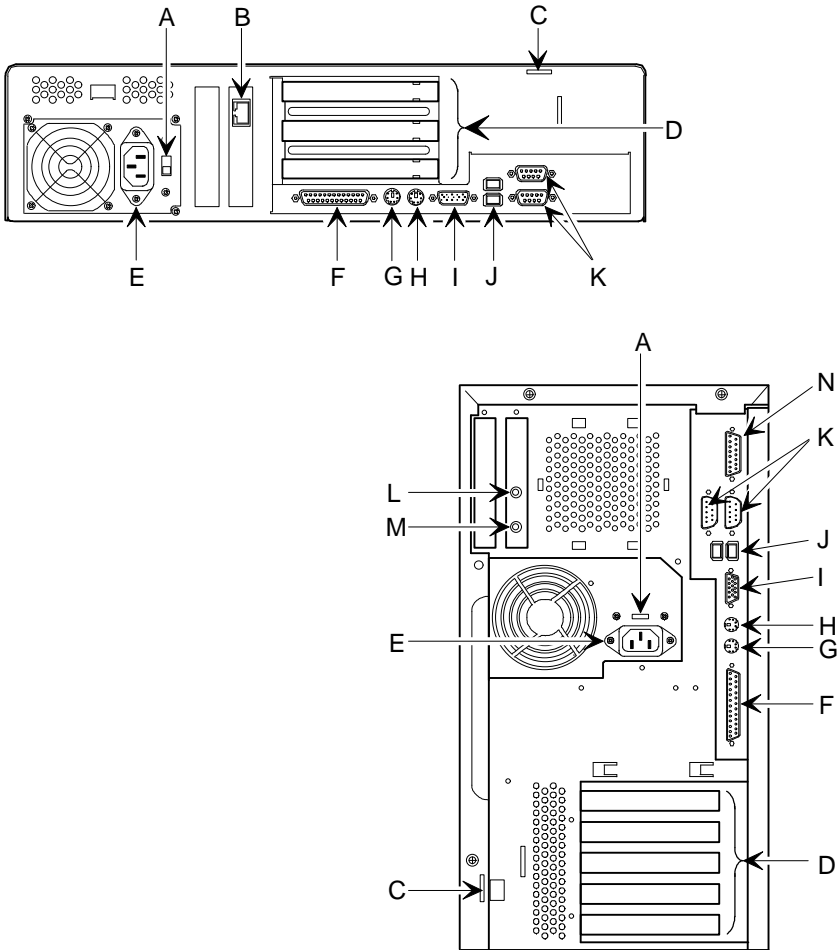

DEC00914-3

Figure 1-2. Rear Panel Connectors and Voltage Select Switch

Typical CD-ROM Front Panel (Yours Might Differ from the One Shown)

Some computers, such as a Venturis FXsm and some Celebris FX models come with a CD-ROM drive. For all other models, the CD-ROM drive is a separately orderable option. The drive shown in Figure 1-3 is a typical front panel, showing the lights, switches, and connectors on most CD-ROM drives. The location of these items might differ depending on your CD-ROM drive.

Legend	Description
A	Headphone jack
B	Volume controls
C	CD loading tray
D	Busy lamp
E	Emergency eject hole
F	Tray open/close button

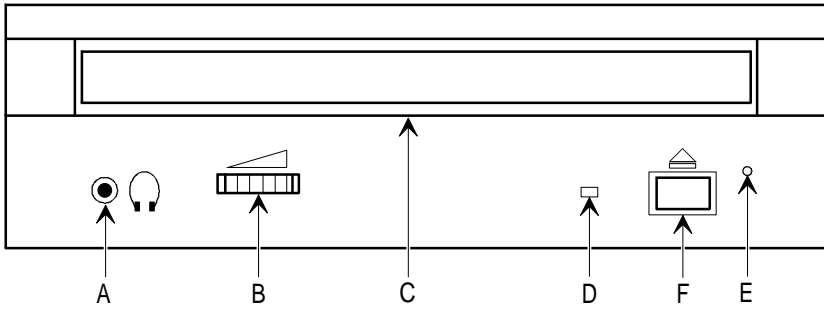

DEC00673

Figure 1-3. Typical CD-ROM Front Panel

Removing your Computer's Outside Cover

To remove your computer's outside cover:

1. Turn off power to all external devices connected to your computer.
2. Turn your computer off.
3. Unplug your computer and monitor power cord from the wall outlet.
4. Remove the outside cover by loosening the thumbscrew(s) at the rear of your computer.
5. Slide the outside cover forward for the low profile and backwards for the short tower.
6. Carefully lift the outside cover away from the chassis.

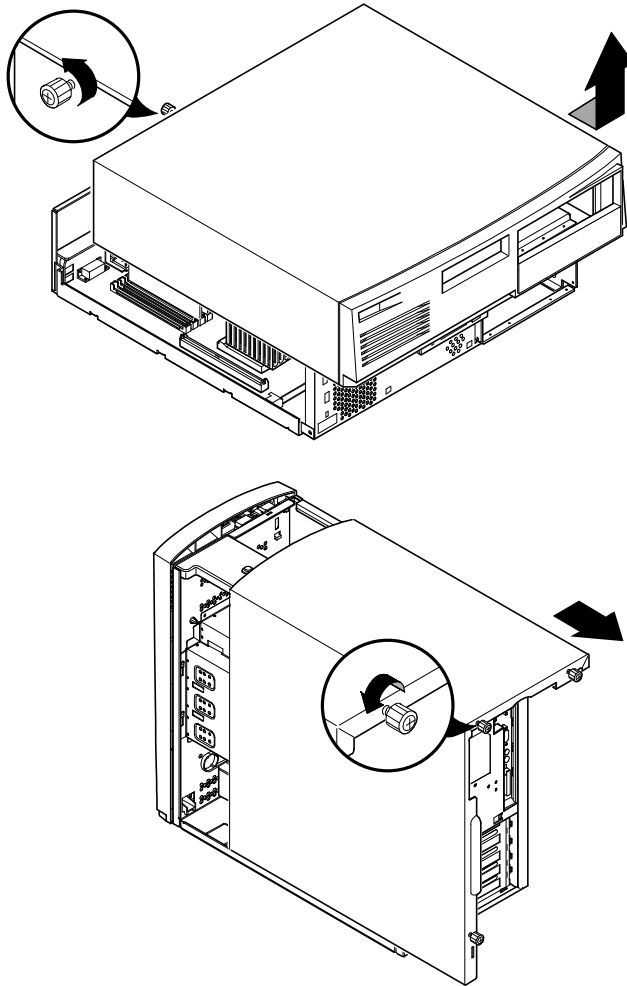

DEC00749-2

Figure 1-4. Removing the Outside Cover

Replacing your Computer's Outside Cover

To replace the outside cover:

1. Replace the outside cover by sliding it onto the chassis.
2. Secure the outside cover to the chassis using the thumbscrew(s).

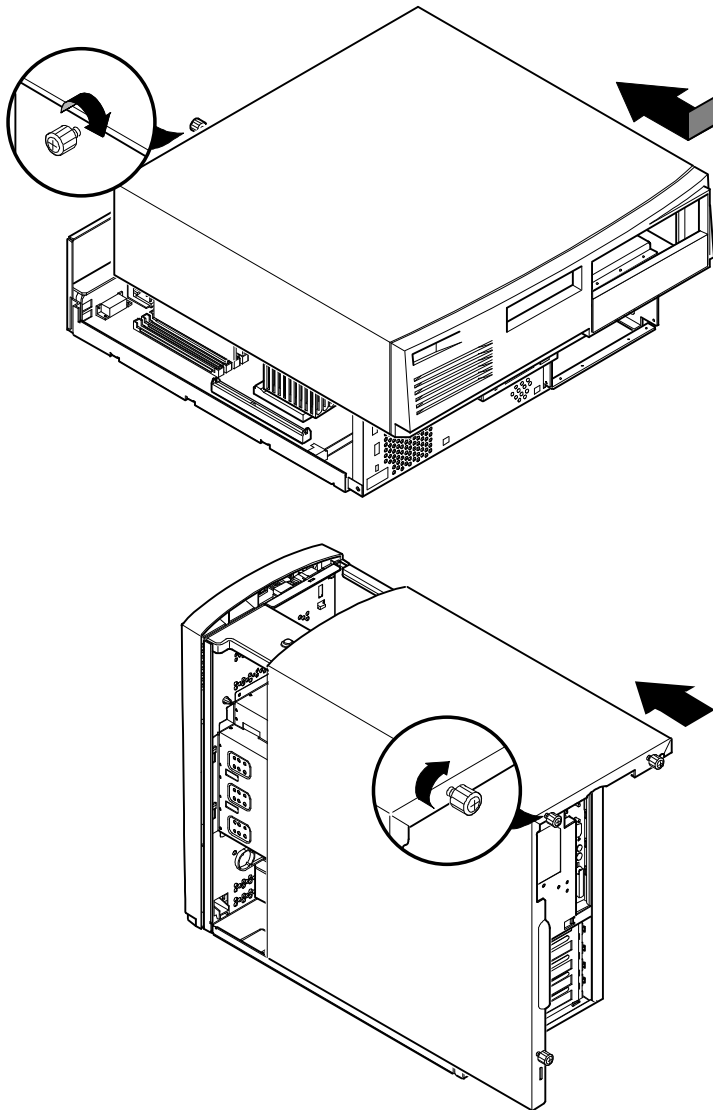

DEC00749-3

Figure 1-5. Replacing the Outside Cover

Chassis Lockdown

A chassis lockdown hasp is located at the rear of your computer. It is either secured to the outside cover or to the side of the chassis. The hasp for Venturis FX and Celebris FX low profile computers is near the top-right of the rear panel. The hasp for Venturis FX short tower computers is at the lower-left of the rear panel. When locked, these hasps prevent others from opening and removing the computer's outside cover. With the hasp in place, you can use a chain or cable lock to secure your computer.

To secure your computer:

1. Turn off the power to all external devices connected to your computer.
2. Turn your computer off.
3. Unplug the computer power cord from the wall outlet.
4. Disconnect the power cord from your computer.
5. Remove the outside cover.



CAUTION: Static electricity collects on non-conductors such as paper, cloth, or plastic. A static discharge can be damaging even though you often cannot see or feel it. To prevent damage to circuit boards and/or components:

Before touching any circuit board or component, touch the metal frame of your computer to discharge any static electricity.

Keep circuit boards and components away from non-conductors.

Attaching the Hasp (Venturis FX and Celebris FX Low Profile)

To attach the hasp:

1. Pull the hasp out from the clip at the rear edge of the cover and then turn the hasp around 180 degrees so the hasp is pointing out to the rear of the computer.
2. Insert the cover clip adjacent to the slot in the rear panel into the slots in the rib of the hasp.
3. Slide the hasp toward you and seat the rib atop the hasp securely to the outside cover.
4. Replace the outside cover, carefully sliding the hasp tab through the slot in the rear panel.
5. Connect the power cord to your computer and to a wall outlet.
6. Turn on all external devices and then turn on your computer.

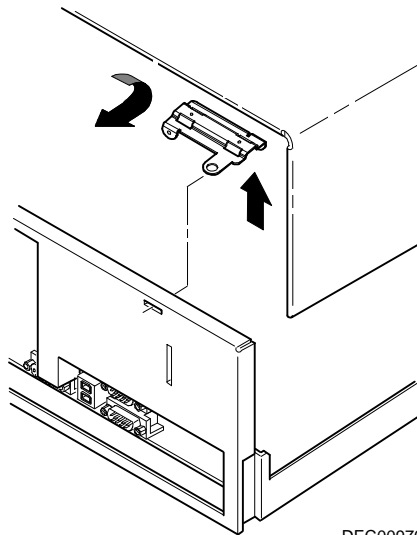
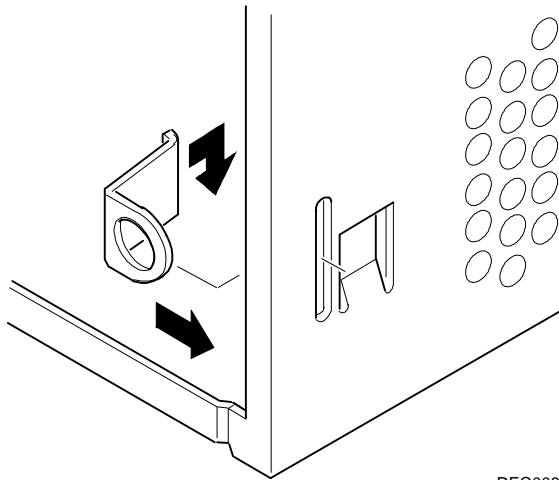

Figure 1-6. Attaching the Hasp (Venturis FX and Celebris FX Low Profile)

Attaching the Hasp (Venturis FX Short Tower Computers)

To attach the hasp:

1. Remove the hasp from the clip and rotate the hasp so it is point out to the rear of the computer.
2. Insert the hasp tab, with the lock/cable hole, through the slot in the rear panel.
3. Slide the foot of the hasp behind the rear panel tongue and seat the foot securely.
4. Replace the outside cover, carefully sliding the left, rear-edge slot over the hasp.
5. Connect the power cord to your computer and to the wall outlet.
6. Turn on all external devices and then turn on your computer.



DEC00881

Figure 1-7. Attaching the Hasp (Venturis FX Short Tower Computers)

Connecting Speakers (Venturis FXsm Only)

If you purchased speakers for your computer, perform the following instructions to connect them:

1. Unpack the speakers.
2. Plug the slave speaker cable into the master speaker “Speaker Out” (A, Figure 1-8).
3. Connect the other cable to the master speaker “Audio Input” (B, Figure 1-8) and to the adapter card “Line Out” (C, Figure 1-8).
4. Connect the ac-to-dc adapter cord to the master speaker (D, Figure 1-8).
5. Plug the speaker ac-to-dc into a power outlet.

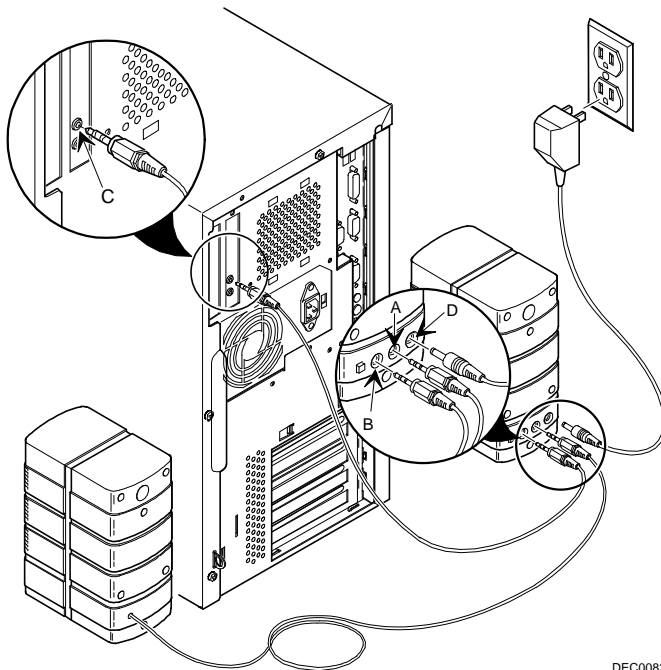

DEC00824

Figure 1-8. Connecting Speakers (Venturis FXsm Only)

Connecting Headphones (Venturis FXsm Only)

If you are a Venturis FXsm user, you received headphones. Following are instructions for connecting them.

1. Unpack the headphones.
2. Connect the headphones cable into the connector at the left/front of your computer.

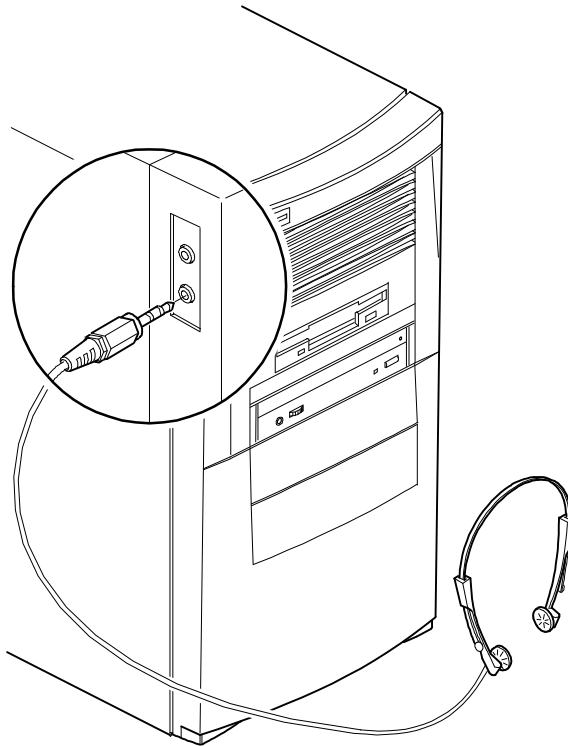

DEC00897-2

Figure 1-9. Connecting Headphones (Venturis FXsm Only)

Connecting a Microphone (Venturis FXsm Only)

If you are a Venturis FXsm user, you received a microphone. Following are instructions for connecting it.

1. Unpack the microphone and assemble the base.
2. Connect the microphone cable into the connector at the left/front of your computer.

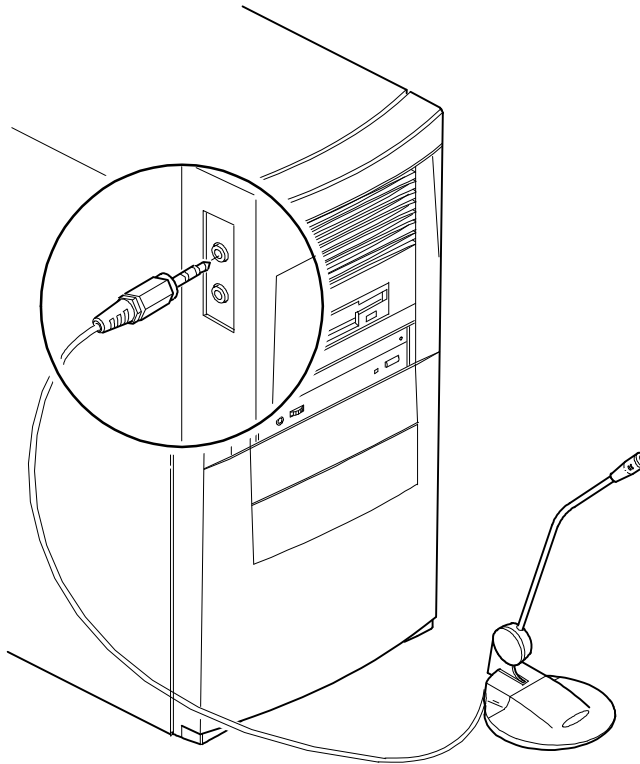

DEC00897-3

Figure 1-10. Connecting a Microphone (Venturis FXsm Only)

Connecting a Local Printer

Perform the following steps to connect a local printer to your computer:

1. Look over your printer documentation and perform any pre-installation instructions before attempting to connect it to your computer.
2. Make sure your printer and computer are turned off.
3. Plug the printer cable into the appropriate printer port (the parallel port for a parallel printer and a serial port for a serial printer).
4. Turn your printer and computer on.
5. Configure your printer for operation with your computer.

Refer to your Windows 95, Windows NT Workstation, or printer documentation for instructions on installing your printer's device driver.

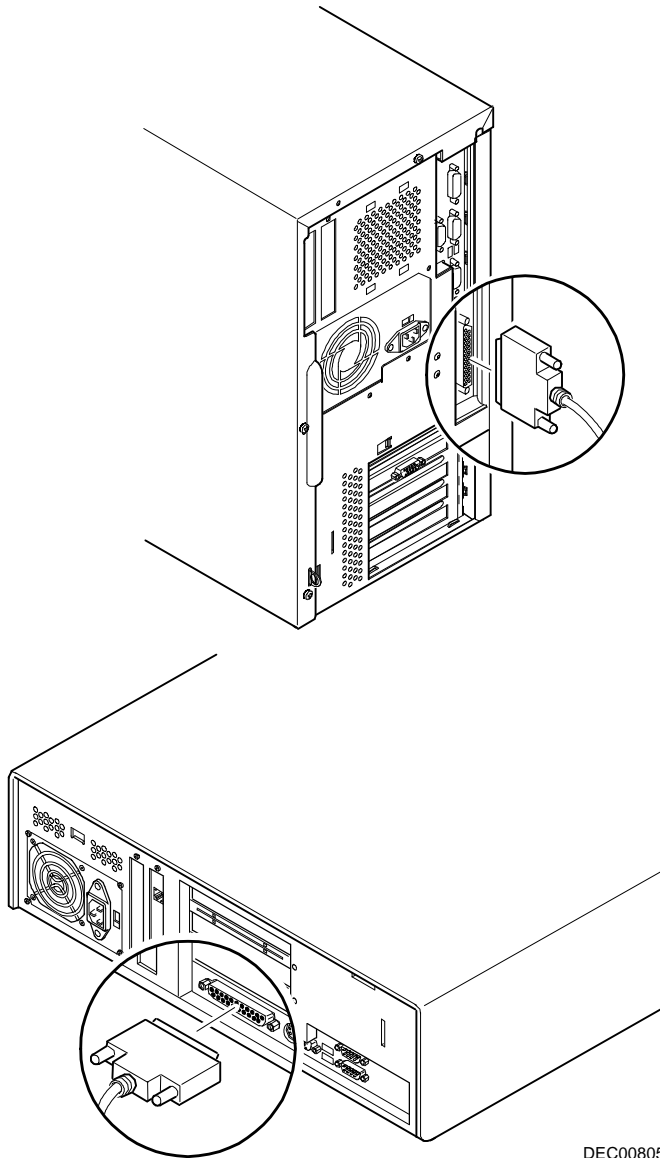

DEC00805

Figure 1-11. Connecting a Printer

Connecting a Universal Serial Bus (USB) Device

If your computer has a USB connector and if you purchased a USB device for your computer, perform the following instructions to connect it:

1. Unpack the USB device.
2. Connect the USB device cable into one of the USB port connectors at the rear of your computer.

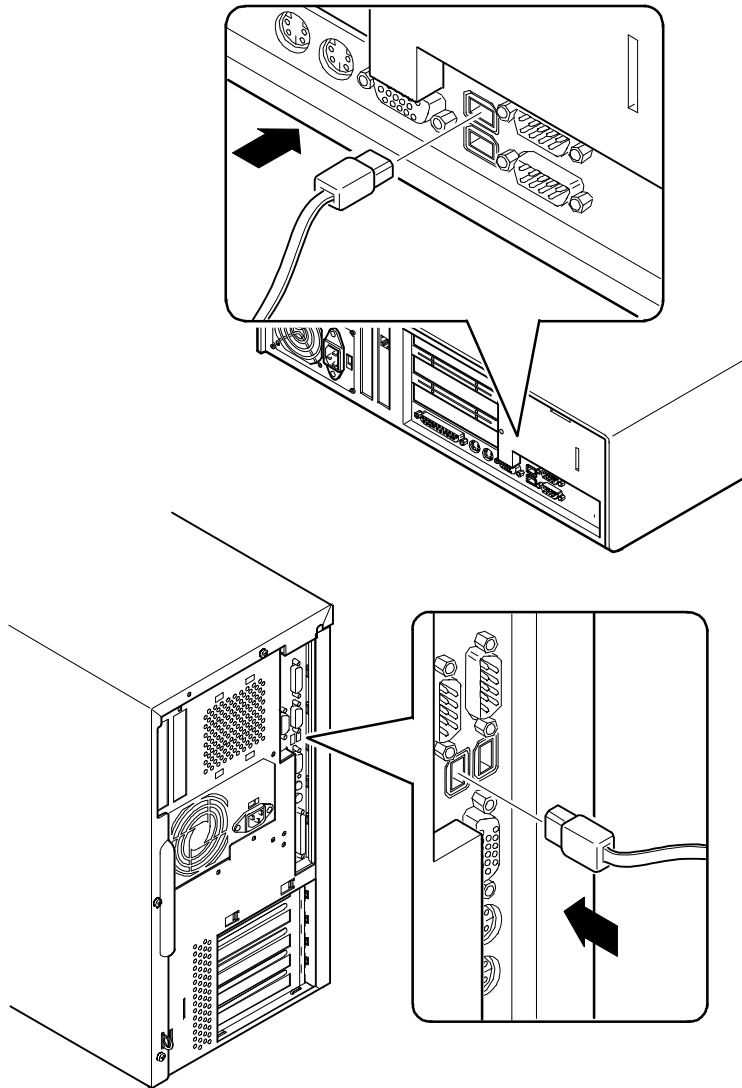

DEC00915-3

Figure 1-12. Connecting a USB Device

Connecting a MIDI/Joystick Device (Venturis FXsm Only)

If you purchased a MIDI/joystick device for your Venturis FXsm computer, perform the following instructions to connect it:

1. Unpack the MIDI/joystick device.
2. Connect the MIDI/joystick device cable into the MIDI port connector on the adapter card.

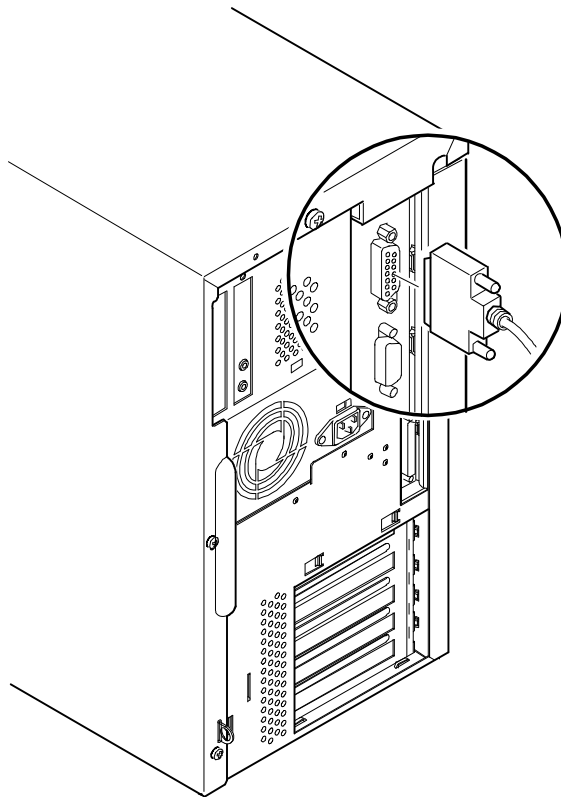

DEC00981

Figure 1-13. Connecting a MIDI/Joystick Device (Venturis FXsm Only)

Your Computer's Windows Enhanced Keyboard

Your computer comes equipped with a 104-key Windows enhanced keyboard that enables you to communicate with your computer by entering data or commands.

The right and left Windows keys (A and B, Figure 1-14) bring up the Start menu much like pointing and clicking the left mouse button on the Start button. These keys can be used at any time you are in the Windows shell and do not affect or change the current mouse position. Both keys can be used to modify other keys. The operating system controls the functionality of the Windows keys and only shell applications should implement these keys.

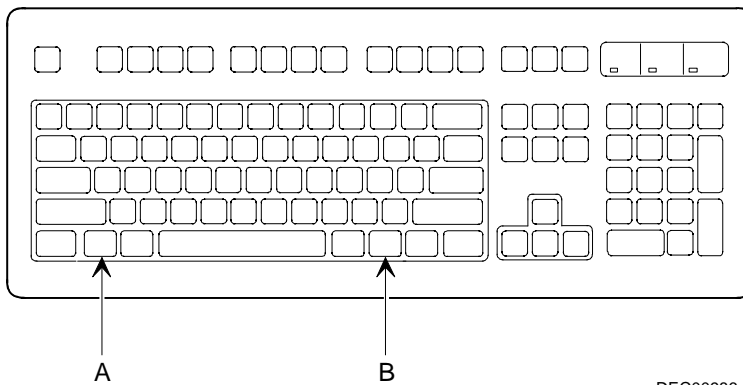

DEC00986-2

Figure 1-14. Windows Enhanced Keyboard

Creating a Comfortable Working Environment

Under circumstances of poor posture or poor setup, certain recent scientific articles suggest that injuries may occur. Other articles suggest that there is no cause and effect. Because the safety of our users is a great concern, it is important to take these precautions:

- Be comfortable in your work space.
- Change your posture frequently.
- Proceed according to the recommendations in the following table and figure.

Adjust	So . . .
Chair	<p>Feet are flat on the floor.</p> <p>Legs are vertical forming a right angle to the floor.</p> <p>Your weight is off your thighs and they are horizontal. Keep the back of your knees away from the seat so you do not compress the area behind them, which could restrict the blood flow.</p> <p>Your upper body is erect and your lower back is supported with a backrest.</p>
Keyboard or mouse	<p>Your wrists are straight and do not bend more than 15 degrees. They may be supported when resting but not on sharp edges. Type comfortably, with no more key pressure than needed to feel the contact point.</p> <p>Upper arms are straight down at your sides, elbows are close to your sides and support your arm weight. Forearms are at a 70 degree to 90 degree angle.</p> <p>If you use a mouse, rest your hand on the mouse so your wrist is not on the work surface. Operate the mouse close to your body's centerline.</p>

continued

Adjust	So . . .
Head	Avoid neck strain. Your head should incline downward, but no more than 15 to 20 degrees.
Monitor	No higher than the level of your eyes and at the correct distance for your vision. Avoid eye fatigue, which can be caused by glare, image quality, uncomfortable furniture, eye height, and uncorrected vision. If you cannot focus to read at different distances, you may need special glasses. Relax your eyes periodically by looking at distant objects.
Work breaks	Take periodic work breaks. Morning, lunch, and afternoon breaks during the 8-hour workday meet most recommendations. Take advantage of work breaks to move around and do other activities.
Lighting	Avoid direct lighting or sunlight on the screen, which causes glare and reflections. Place lighting behind or to the side of your work area, and distribute the lighting evenly on your work area. Your computer monitor's screen has an antiglare treatment to reduce glare. Adjust the brightness and contrast controls as needed.
Noise	Keep background noise at a minimum. Background noise above 65 dBA is tiring. Sound-absorbing materials (curtains, carpeting, and acoustic tile) can help reduce background noise.
Temperature	20 to 23 degrees C (68 to 74 degrees F).
Humidity	30% to 70%.
Ventilation	Provide adequate air ventilation to avoid fatigue and to operate the equipment.
Space between set ups	> 70 cm (28 in.) center to center, preferably > 152 cm (60 in.).

IMPORTANT: If you experience pain or discomfort during use of the PC, take a rest break and review the instructions for proper ergonomic setup and use. If the pain or discomfort continues after resuming use of the PC, discontinue use and report the condition to your job supervisor or physician.

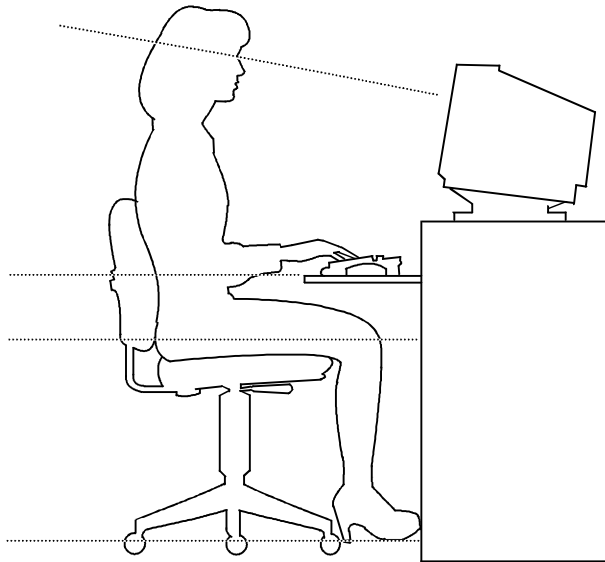

DEC00454

Figure 1-15. Creating a Comfortable Working Environment

Using the BIOS Setup Utility **2**

What is the BIOS Setup Utility?

The BIOS Setup utility enables you to select and store permanently information about your computer's hardware and software in the battery-backed memory of the CMOS RAM. This information takes effect each time the computer boots and can be changed any time you run setup.

You should use the BIOS Setup utility if you experience problems with your hard disk or if you need to reconfigure or expand your computer.

This chapter provides information on how to configure your computer using the BIOS Setup utility.



CAUTION: Your computer was setup for normal operation at the factory and will operate properly without additional configuring.

It is important for you to read carefully and understand this chapter before attempting to modify your computer's factory settings. Changing some settings might cause your computer to operate improperly.

Here are some instances when you might wish to change your computer's initial setup. You might need to:

- Change time and date
- Alter your computer's security level

Using the BIOS Setup Utility

- Change the boot options
- Reconfigure power management
- Setup your keyboard for your comfort and use

Additionally, you will need to change your computer's initial setup after:

- Upgrading hardware (such as adding a new hard drive)
- Reconfiguring your mouse, COM, or LPT ports



NOTE: If you do change BIOS settings, make sure you record the new settings and keep this information in a safe place. Should you ever have to reset the settings, such as when you replace your battery, you can use this information to reconfigure your computer's BIOS.

The remainder of this chapter explains how to run the BIOS Setup utility, maneuver through the options, and perform specific tasks.

Accessing the BIOS Setup Utility

To access the BIOS Setup utility, perform the following steps:

1. Turn on your computer and allow the Power-On Self Test (POST) to complete.
2. Make a note of any configuration errors listed, and then press [F2] to display the Main menu.
3. Follow the instructions on your monitor screen and any on-line help pop-up screens to configure you computer.

Helpful Hints

When using the BIOS Setup utility consider:

- Several keyboard keys are assigned to help you select menus and sub-menus, options, change option values, and display help information. These keys are displayed at the bottom of all menus, and are listed in the following table.

Key	Function
F1	Help (provides a general help screen)
Esc	Exit (Exits the Setup utility and exits sub menus within the Setup utility)
↑↓ arrow keys	Select Item
← → arrow keys	Select Menu
-/+ or spacebar	Change Values
Enter	Select > Sub-Menu
F9	Setup Defaults (Sets all Setup options to factory default values)
F10	Previous Values (Restores all BIOS values from the last session)

- Item-specific help is available anytime during the setup process and appears at the right of the setup screen when an option is highlighted.
- Choosing the “Exit” menu reveals several helpful options:
 - Select “Save Changes & Exit” to save all Setup values and exit Setup.
 - Select “Exit Without Saving Changes” to exit Setup without recording any changes.



NOTE: Answer the Warning message carefully.

- Select “Get Default Values” to set all setup options to their factory default values.
- Select “Load Previous Values” to restore all setup values from the last session.
- Select “Save Changes” to save all setup selections without exiting Setup.

Changing Your Computer's Configuration

The following sections provide detailed information on changing your computer's factory configuration. Before changing any setting, make sure you fully read and understand the information provided and view any on-line help for a selected setting.

Changing Time and Date

There may be instances when it will be necessary, such as daylight savings or if you move to a different time zone, to change the date and/or time that is resident in your computer's BIOS. The following directions show you how this is done.

1. Reboot the computer and enter Setup.
2. In the Main menu, using the cursor keys and [Tab], select (highlight) the System Time or System Date field you want to change.
3. Use [+] or [-] to change the field to the desired value.

You can also enter the desired date and time.

4. Save Changes and Exit Setup and allow your computer to reboot.

Setting Up Security

Computer security is important to prevent theft or accidental loss of your computer software. The following sections describe the security features available and how to use them.

Setting Supervisor and User Passwords

Your computer has two password levels that can be set to prevent unauthorized access to computer files or to the BIOS Setup utility. If a supervisor password is set, the computer asks you to enter a password before accessing the BIOS Setup utility.

If "Password On Boot" is enabled, and both the supervisor and user passwords are entered, you need to enter either the supervisor or user password to use the computer. Password on boot limits who accesses the computer and at what level of functionality you receive.

Once a supervisor password is set, the computer is prevented from booting if the user password is entered at boot instead of the supervisor password.

Additionally, if after selecting [F2] during the boot sequence, the user password is entered instead of the supervisor password, the Main, Advanced and Power menus in the BIOS Setup utility are rendered inaccessible.



NOTE: A supervisor password must be set before you can set a user password. If the supervisor password is later deleted, the user password is automatically removed.

Perform the following steps to set a supervisor password:

1. Reboot the computer and enter Setup.
2. Highlight the “Security” menu.
3. Highlight “Set Supervisor Password” and press [Enter].
4. Type in a seven (7) digit alpha-numeric supervisor password and then press [Enter].
5. Retype your password as instructed and press [Enter]. (Notice that “Supervisor Password Is” field now indicates Enabled.)

If desired, set a user password as follows:

1. Highlight “Set User Password” and press [Enter].
2. Type in a seven (7) digit alpha-numeric user password and then press [Enter].
3. To confirm, retype your user password as instructed and press [Enter]. (Notice that “User Password Is” field now indicates Enabled.)
4. Press [Esc] then [Enter] twice to exit the BIOS Setup utility and to reboot the computer so changes immediately take affect.

The computer runs the POST and then asks for the password, which has just been set.

Enabling Password On Boot

If “Password On Boot” is enabled and both the supervisor and the user passwords are enabled, you must enter either the supervisor or user password (which ever is appropriate). These passwords are necessary to use your computer. In other words, the purpose of “Password On Boot” is to limit who accesses your computer and at what level of functionality a user receives.

Perform the following steps to set “Password On Boot”:

1. Reboot the computer and enter Setup.
2. Highlight the “Security” menu.
3. Highlight “Password On Boot.”
4. Press the [+] key. (Pressing the [+] key again reverses your action.)
5. Press [Esc] then [Enter] twice to exit the BIOS Setup utility and to reboot the computer so changes immediately take affect.

Eliminating User and Supervisor Passwords

To eliminate your computer's password(s), follow the directions given below:

1. Reboot the computer and enter Setup.
2. Enter the supervisor password and press [Enter].
3. Do you wish to eliminate the User Password or the Supervisor Password?

If User Password, select "Set User Password."

If Supervisor Password, select "Set Supervisor Password."

4. Press Enter three times.

You have cleared the old password and are returned to the "Security" menu. Verify that the appropriate password is disabled by checking "User Password is" or the "Supervisor Password is" field, whichever is relevant.

5. Press [Esc] then [Enter] twice to exit the BIOS Setup utility and to reboot the computer so changes immediately take affect.

Protecting Against Boot Sector Viruses

Your computer incorporates, in the BIOS Setup utility, a selection to write protect the fixed disk boot sector. By write-protecting the boot sector, you can protect your computer against viruses that corrupt the boot sector.

The “Fixed Disk Boot Sector” line in the Security menu allows you to enable a very important anti-virus attribute. Selecting “Write-Protect” can help you to protect your hard disk from being corrupted by viruses, which could disable your hard disk.

To write-protect your fixed disk boot sector:

1. Reboot the computer and enter Setup.
2. Highlight the “Security” menu.
3. Highlight “Fixed Disk Boot Sector.”
4. Press the [+] key to enable write-protect (pressing the [+] key again, returns your computer to normal).
5. Press [Esc] then [Enter] twice to exit the BIOS Setup utility and to reboot the computer so changes immediately take affect.

Other Security Options

These options can provide further security for your computer under certain conditions.



CAUTION: Consider your security needs carefully before using the following option. While this option is enabled, the contents of the hard disk drive cannot be backed up to diskettes and the computer cannot be booted from a diskette drive.

- If “Password On Boot” is enabled and “Diskette Access” is set to “Supervisor,” entering the supervisor password at boot allows access to a diskette. Entering the user password at boot, however, prevents the computer from accessing a diskette.
- *Custom Sign On Banner* – When enabled, allows a custom banner to be displayed every time you turn your computer on.
- *Diskette Access* – While enabled, this option prevents the computer from accessing a diskette.
- *Network Server* – Locks the keyboard and mouse to prevent tampering during network operation. You must enter a supervisor password to unlock the keyboard and mouse.
- *Suspend Lock System* – Found in the “Power” menu, this feature is enabled if your Power Management selections put your computer into the “System Standby” or “System Suspend” modes. This feature disables your keyboard and mouse; you can reactivate them after entering a password.



NOTE: The Suspend Lock System key combination enabled in Setup will be the combination required to place your computer automatically into standby.

Setting Power Management Options

This section describes how to select and set your computer's Power Management parameters using the BIOS Setup utility.



NOTE: You can use Digital's Power Management utility to set your computer's power management features (Windows 95 only).

Setting up Power Management



NOTE: None of the power management features available in the BIOS Setup utility apply unless the "Power Management" field is set to *Enabled*.

To initialize the power management features:

1. Reboot the computer and enter Setup.
2. Highlight the "Power" menu.
3. Highlight "Power Management."
4. Press the [+] key to select Enable (pressing the [+] key again, returns your computer to Disable).



NOTE: "System Standby Timer" and "System Suspend Timer" have been preset to 5 minutes and 1.5 hours respectively. You can change these times by selecting them and pressing the + key to sequence through the available options.

5. Choose other Power Management options as desired.
6. Press [Esc] then [Enter] twice to exit the BIOS Setup utility and to reboot the computer so changes immediately take affect.

Putting Your Computer Quickly into Full Power Management

Enabling “Quick Suspend” allows the selection of a three-key command (such as [Ctrl]+[Alt]+[Esc]) that, when activated from your keyboard (at any time after boot), puts the computer immediately into the “System Standby” power management mode. (Touching any key or your mouse restores your computer to normal operation.)



NOTE: As with any other power management feature, the “Power Savings” field must read Enabled before this feature can be used.

To initialize the “Quick Suspend” feature:

1. Reboot the computer and enter Setup.
2. Highlight the “Power Management” menu.
3. Highlight “Quick Suspend.”
4. Press the [+] key to sequence through the available options.
5. Select an option.
6. Press [Esc] then [Enter] twice to exit the BIOS Setup utility and to reboot the computer so changes immediately take affect.

Configuring for New Disk Drives

These sections describe how to configure new disk drives in the BIOS Setup utility.

Diskette Drive Configuration

Diskette drives need to be configured from within the BIOS Setup utility once the new diskette drive is installed.

To configure a newly installed diskette drive, proceed as follows:

1. Reboot the computer and enter Setup.
2. Highlight the Main menu.
3. Highlight "Diskette A" or "Diskette B" (depending upon how you connected the diskette drive to your computer).
4. Press the [+] key to sequence through the available options.
5. Press [Esc] then [Enter] twice to exit the BIOS Setup utility and to reboot the computer so changes immediately take affect.

Hard Disk Drive Configuration

Installing new ANSI-supported IDE hard disks is made easier by the “Autotype” drive detect mode available in the BIOS Setup utility.

Autotyping a Hard Disk

To Autotype a newly installed hard disk:

1. Reboot the computer and enter Setup.
2. Highlight the “Main” menu.
3. Select an “IDE Adapter” field to assign the new hard disk and press [Enter].
4. Select “Autotype Fixed Disk” and press [Enter].

The BIOS Setup utility searches the hard disk and fills-in the disk parameters. If a parameter does not read correctly, follow the “Manually Defining a Hard Disk” procedure given later in this chapter.

5. Press [Esc] once and verify that the selected IDE Adapter field reads correctly for your hard disk.

For example: IDE Adapter 0 Master (C: 835 MB). If the selected IDE Adapter field does not read correctly, follow the “Manually Defining a Hard Disk” procedure given later in this chapter.

6. Press [Esc] once then [Enter] twice to exit the BIOS Setup utility and to reboot the computer so changes immediately take affect.

Manually Defining a Hard Disk

If your hard disk was not recognized correctly by the Autotype mode in the BIOS Setup utility, or you wish to change your hard disk's definition, you can manually define your hard disk drive as follows:

1. Reboot the computer and enter Setup.
2. Highlight the "Main" menu.
3. Select an "IDE Adapter" field to assign the new hard disk and press [Enter].
4. Fill-in the parameters of the hard disk in the appropriate fields.
5. Press [Esc] once and verify that the selected IDE Adapter field reads correctly for your hard disk. For example: IDE Adapter 0 Master (C: 835 MB).
6. Press [Esc], then [Enter] twice to exit the BIOS Setup utility and to reboot the computer so changes immediately take affect.

Changing the Boot Sequence

It is sometimes necessary to change your computer's boot sequence. For example, when connecting to a network. (Follow your network manual's instructions to determine the correct boot sequence.)

To change the boot sequence, proceed as follows:

1. Reboot the computer and enter Setup.
2. Highlight the "Boot" menu.

Diskette drive, Hard Disk, and CD-ROM Drive are displayed. The number shows the current ordering. For example, if CD-ROM Drive is 1 and Diskette Drive is 2, the computer boots first from the CD-ROM drive. If it is empty, the computer goes to the diskette drive and then finally to the hard disk drive.

3. Use the [↑] and [↓] arrows to locate the field you want to change. Then use the [+] to raise the order and [-] to lower it.
4. Press [Esc] twice then [Enter] twice to exit the BIOS Setup utility and to reboot the computer so changes immediately take affect.

Speeding up the Boot Process

There are three options for speeding up the boot process. They in essence eliminate or replace displays or checks. To make these changes, proceed as follows:

1. Reboot the computer and enter Setup.
2. Highlight the Main menu.
3. Highlight "Boot Options" and then press [Enter].

The following table lists the items displayed and describes them.

Field	Description
Summary screen	Displays the computers configuration
Quiet boot	Replaces POST boot messages with a display of the Digital logo
Floppy check	Verifies the floppy boot drive

4. Select the item(s) you wish to change and use the [+] or [-] as follows:

Field	Speed Up Boot Selection
Summary	Disable
Quiet boot	Enable
Floppy check	Disable

5. Press [Esc] twice then [Enter] twice to exit the BIOS Setup utility and to reboot the computer so changes immediately take effect.

Resetting Keyboard Features

Several parameters effecting keyboard performance can be altered from within the BIOS Setup utility. They are: “NumLock,” “Key Click,” and “Keyboard Auto-Repeat Delay.”

- “NumLock” is factory set to “Auto” at boot which means that the number pad is on each time you boot. This is desirable, for example, if you primarily use spreadsheets or accounting software.

If, however, you primarily use a word processor or desktop publishing program, you might wish to leave NumLock off at boot to avoid having to turn it off manually.

- “Key Click,” when enabled, produces an audible “Click” whenever a key is pressed.

Most keys on the keyboard automatically repeat the character they represent if the keys are held down.

- “Keyboard Auto-Repeat Rate” sets the number of times per second a character repeats.
- “Keyboard Auto-Repeat Delay” sets the time that elapses before the character begins repeating.

Changing the Keyboard Features

To change the keyboard features:

1. Reboot the computer and enter Setup.
2. Highlight the “Main” menu.
3. Highlight “Keyboard Features” and press [Enter].

If you wish to leave “NumLock” on, skip steps 6 and 7, otherwise:

4. Highlight “NumLock.”
5. Press the [+] key to sequence through your options, select “Off.”

If you wish to leave “Key Click” disabled, skip steps 8 and 9, otherwise:

6. Select “Key Click.”
7. Press the [+] key to select `Enable`.

If you wish to leave the “Keyboard Auto-Repeat Rate” (the number of times per second a character repeats) the same, skip steps 8 and 9, otherwise:

8. Highlight “Keyboard Auto-Repeat Rate.”
9. Press the [+] key to sequence through the available options.

If you wish to leave the “Keyboard Auto-Repeat Delay” (the time that elapses before the character begins repeating) the same, skip steps 10 and 11, otherwise:

10. Highlight “Keyboard Auto-Repeat Delay.”
11. Press the [+] key to sequence through the available options.
12. Press [Esc] twice then [Enter] twice to exit the BIOS Setup utility and to reboot the computer so changes immediately take effect.

Setting Your Computer's Volume Control

If your computer has an onboard ESS sound chip, you must enable the "Integrated Audio" option using the BIOS Setup utility. If your computer does not have an onboard ESS sound chip, leave this option "Disabled."

To enable this option, proceed as follows:

1. Reboot the computer and enter Setup.
2. Highlight the Advanced menu and press [Enter].
3. Highlight Integrated Peripherals and press [Enter].
4. Highlight "Integrated Audio" and select `Enabled`.
5. Highlight "System Speaker Volume," choose an appropriate volume setting, and then press [Enter].
6. Press [Esc] twice then [Enter] twice to exit the BIOS Setup utility and to reboot the computer so changes immediately take affect.



NOTE: You can also adjust your computer's speaker volume using an audio application within Windows 95 or Windows NT Workstation. Refer to the Windows 95 or Windows NT Workstation on-line help for more information.

Flash Utility

All Venturis FX and Celebris FX computers have BIOS software in a read-only, non-volatile memory (ROM) chip. This BIOS initializes hardware and boots the operating system when the computer is turned on. The BIOS also provides access to other services such as keyboard and disk drives.

Your computer comes equipped with flash memory. This means that you can restore your computer's BIOS simply by running the flash utility. If necessary, you can also upgrade your computer's BIOS to future releases by running the flash utility along with any flash BIOS update diskette.

Using the BIOS Setup Utility

Only use the flash utility to upgrade your computer's BIOS if you are instructed to do so by an authorized Digital support representative. Instructions on how to flash your BIOS, the flash utility, and BIOS updates are available on the Digital Bulletin Board (BBS) or on the Internet.

Refer to the "Preface" for additional access information.

Inside Your Computer **3**

Introduction

This chapter shows the location of the Venturis FX and Celebris FX computer's internal components. Expansion information is also covered in this chapter along with illustrations detailing the:

- Main logic board
- Backplanes

Each computer contains a main logic board and a backplane. The main logic board provides most of the chips, components, and a connector for installing an optional WaveTable daughter card (Venturis FXsm only). The backplane contains slots for connecting expansion boards.

The chapter concludes with instructions on how to:

- Remove the short tower main logic board (required when replacing the battery or, on Venturis FXsm models, when installing an optional WaveTable daughter card)
- Replace the battery
- Install to a higher-performance processor
- Install a Voltage Regulator Module (VRM)

Preparing Your Computer for Expansion

Before you begin to expand your computer, refer to Chapter 1, “Beyond Quick Setup,” for instructions on preventing component damage from static electricity, disconnecting external devices, and removing the outside cover.

Your Computer’s Components and Connectors

The following sections show your computer’s main logic board, backplane, and adapter card component and connector locations. Use the information presented anytime you need to connect external devices, expand, or upgrade your computer.

Computer Components

Figure Legend	Component
A	Main logic board (MLB)
B	Internal 3½-inch drive bay(s)
C	Backplane
D	Power supply
E	Front access 5¼-inch drive bay with CD-ROM (not available on all models)
F	Front access 5¼-inch drive bay(s)
G	3½-inch diskette drive

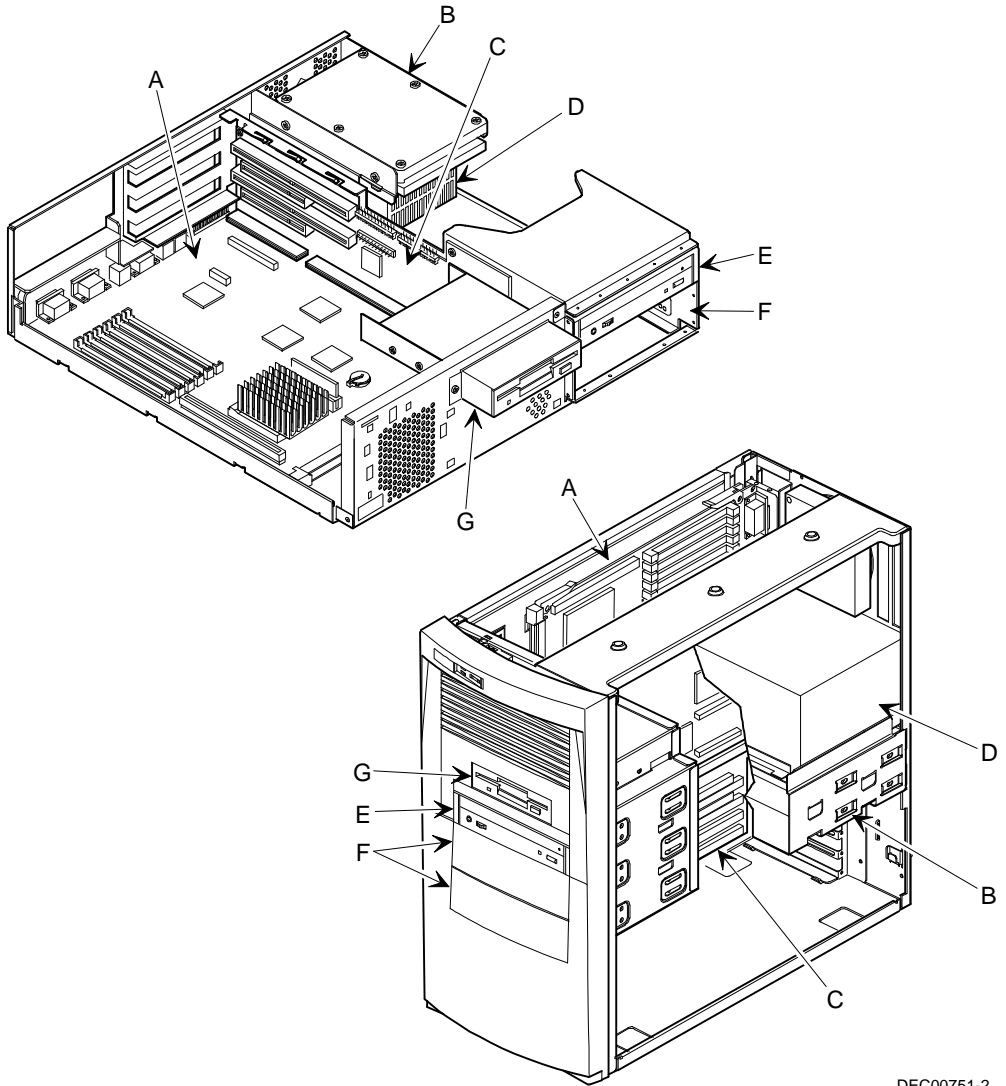

DEC00751-2

Figure 3-1. Computer Components

Main Logic Board Components

Figure Legend	Component
A	Onboard EDO video memory
B	S3 series video controller
C	Keyboard controller
D	PCI-to-ISA bridge
E	Super I/O controller
F	Computer battery
G	Computer flash and video BIOS
H	Cache memory controller
I	Voltage regulator module (VRM)
J	Microprocessor (CPU)
K	PCI local data buffer
L	16-bit stereo sound chip (Venturis FXsm only)

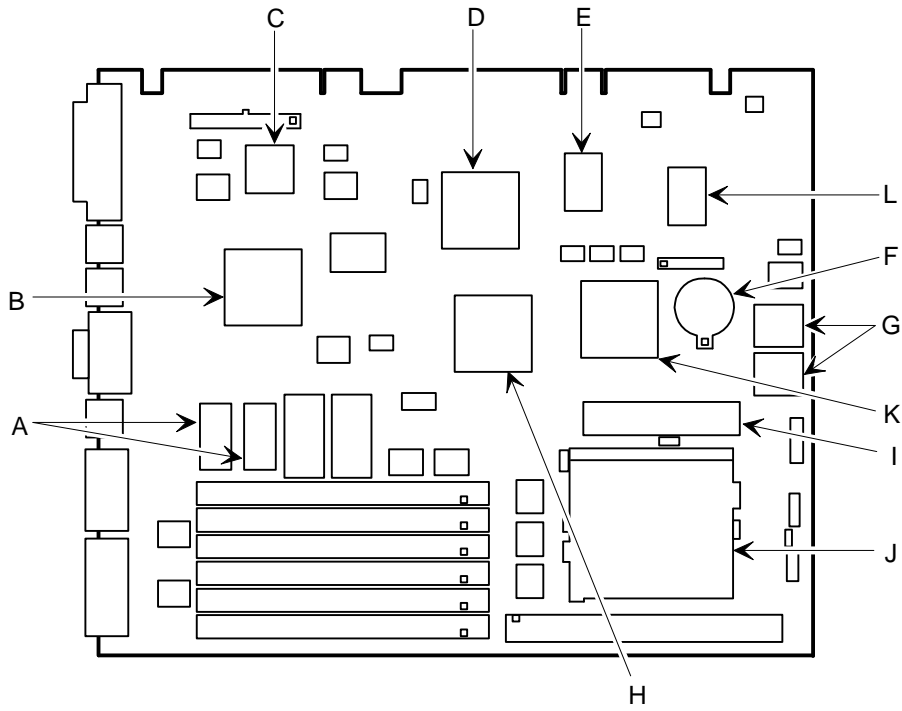

DEC00752-2

Figure 3-2. Main Logic Board Components

Main Logic Board Connectors (Rear Panel)

Figure Legend	Connector
A	Parallel port
B	Keyboard port
C	Mouse port
D	Video (VGA) port
E	Two USB ports (not available on some models)
F	Two serial ports, stacked (COM1 top, COM2 bottom)
G	MIDI/joystick port (Venturis FXsm only)

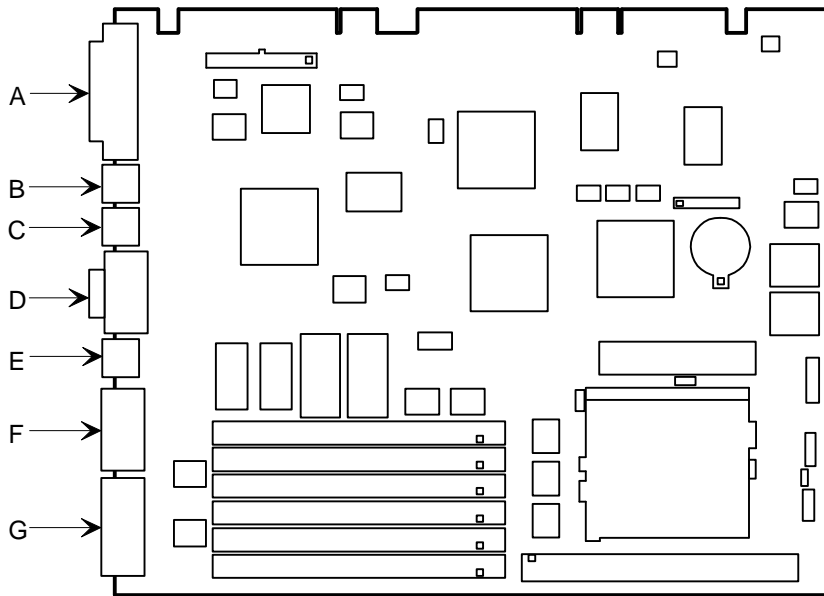

DEC00752-3

Figure 3-3. Main Logic Board Components (Rear Panel)

Main Logic Board Connectors

Figure Legend	Connector
A	Video memory upgrade sockets (not available on some models)
B	VGA feature connector (output only)
C	WaveTable connector (Venturis FXsm only)
D	Auxiliary fan power
E	CPU socket
F	Secondary cache module [COAST (Cache On A Stick) standard module]
G	Four or six 72-pin, 32-bit SIMM sockets (depending on your model)

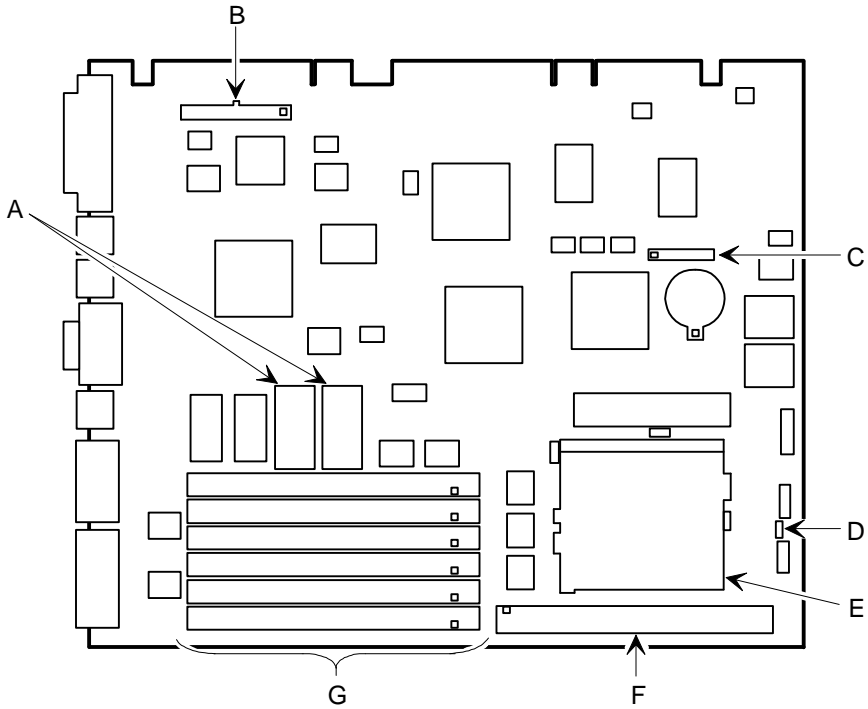

DEC00752-4

Figure 3-4. Main Logic Board Connectors

Venturis FX Low Profile Backplane Components and Connectors

Figure Legend	Connector
A	PCI expansion board connectors
B	ISA expansion board connectors
C	Primary PCI IDE drive connector
D	Secondary PCI IDE drive connector (recommended for CD-ROM drive connection)
E	Diskette drive connector
F	SCSI LED connector
G	Fan connector
H	Front panel connector
I	Power connector
J	Main logic board connectors

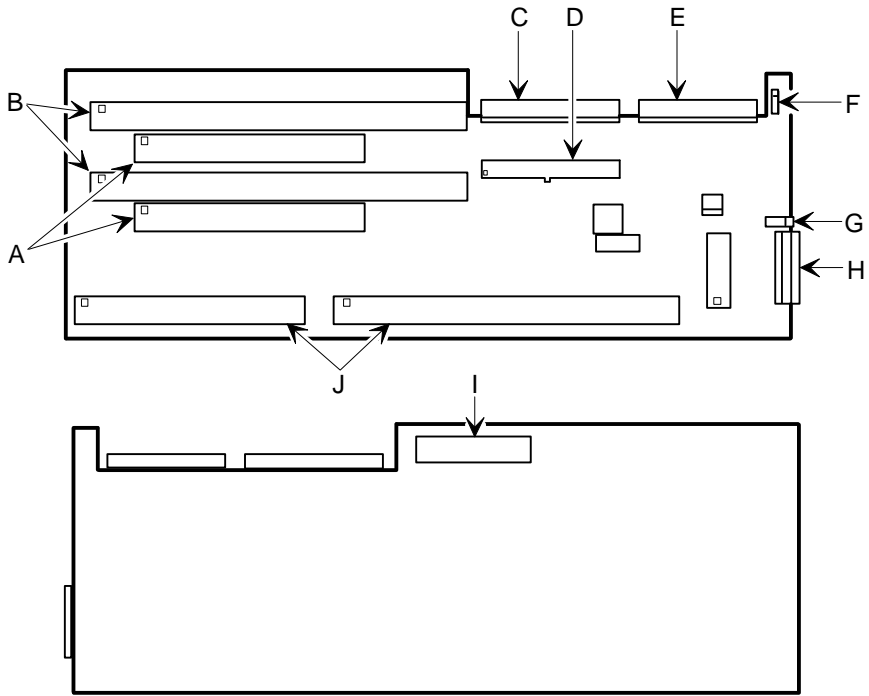

DEC00753-2

Figure 3-5. Venturis FX Low Profile Backplane Components and Connectors

Celebris FX Low Profile Backplane Components and Connectors

Figure Legend	Connector
A	PCI expansion board connectors
B	ISA expansion board connectors
C	Primary PCI IDE drive connector
D	Secondary PCI IDE drive connector (recommended for CD-ROM drive connection)
E	Diskette drive connector
F	T/P IN connector (Twisted-Pair) (not available on all models)
G	SCSI LED connector
H	Fan connector
I	Front panel connector
J	Digital PCI Ethernet controller (not available on all models)
K	Power connector
L	Main logic board connectors

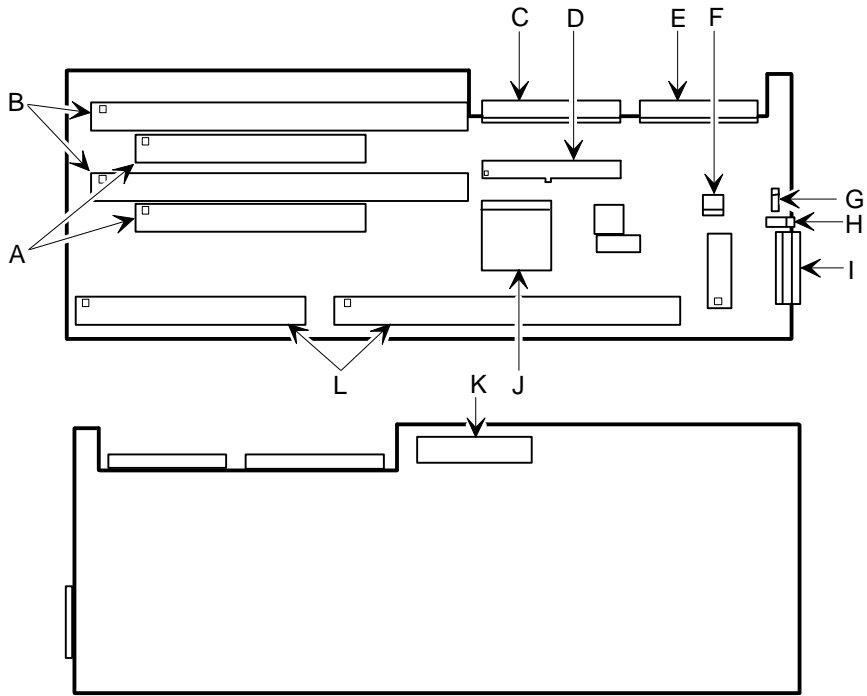

DEC00985-2

Figure 3-6. Celebris FX Low Profile Backplane Components and Connectors

Venturis FX Short Tower Backplane Components and Connectors

Figure Legend	Connector
A	Front panel connector
B	CD-ROM audio input connector (CD-IN) (Venturis FXsm only)
C	SCSI LED connector
D	Primary PCI IDE drive connector
E	Secondary PCI IDE drive connector (recommended for CD-ROM drive connection)
F	Main logic board connectors
G	Power connector
H	Audio out connector (Venturis FXsm only)
I	PCI expansion board connectors
J	Fan 2 connector
K	ISA expansion board connectors
L	Diskette drive connector
M	Audio IN connector (Venturis FXsm only)
N	Fan 3 connector
O	Spatializer 3-D stereo chip (Venturis FXsm only)

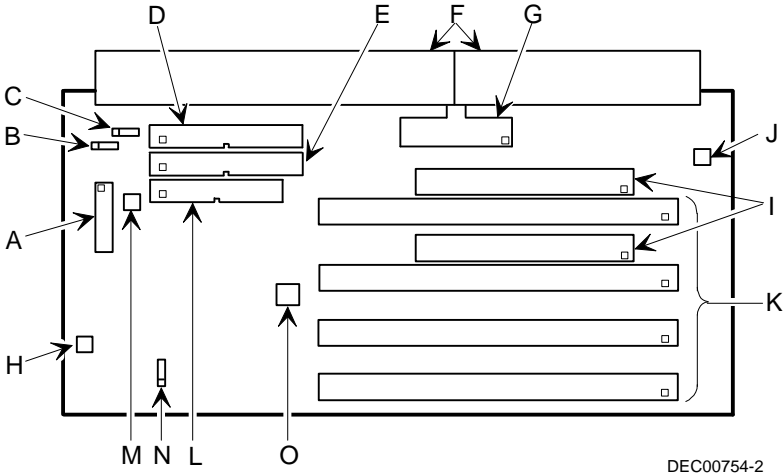

DEC00754-2

Figure 3-7. Venturis FX Short Tower Backplane Components and Connectors

Celebris FX Network Adapter Card Connector

Celebris FX computers are network ready. You can use the 10Base-T (A, Figure 3-8) port at the rear of your computer to connect your external network cable. The internal network cable is already installed for you.

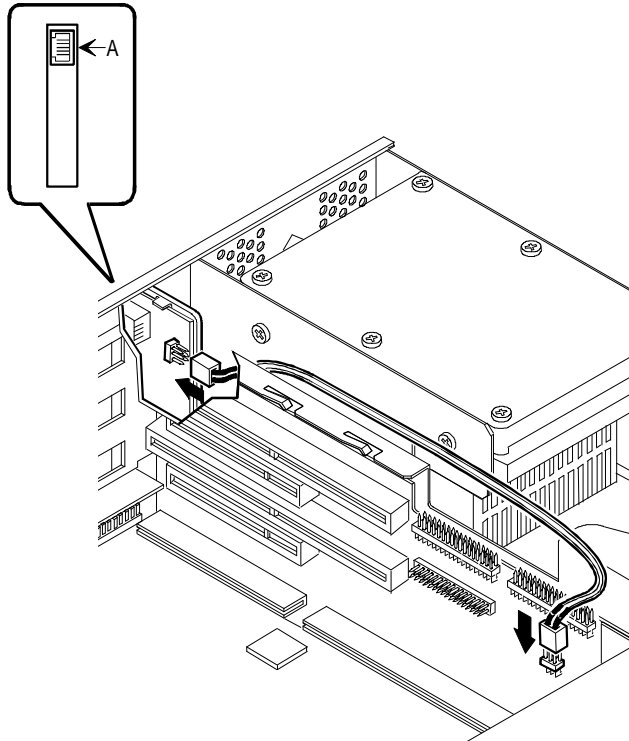

DEC00764

Figure 3-8. Celebris FX Network Adapter Card Connector

Audio Adapter Card Connections (Venturis FXsm Only)

Figure Legend	Connector
A	Speaker out
B	Audio IN

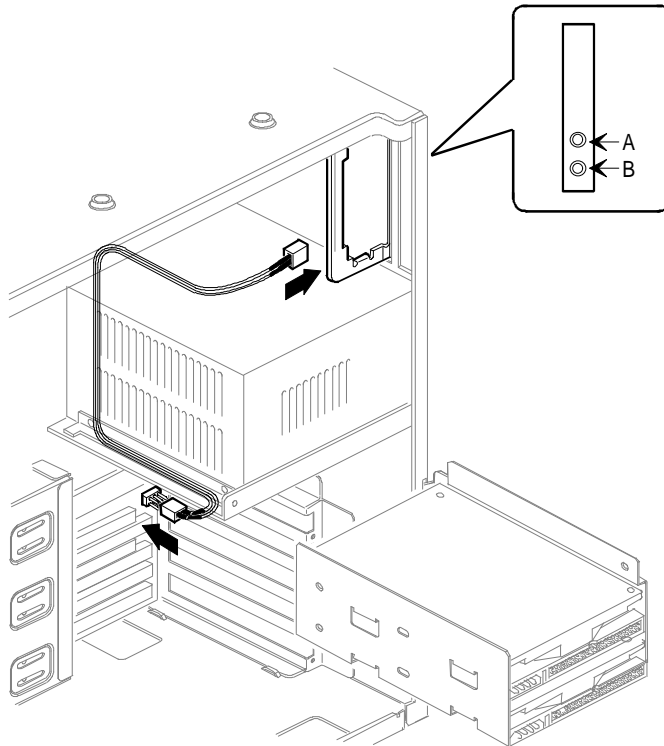

DEC00823-3

Figure 3-9. Audio Adapter Card Connections (Venturis FXsm Only)

Removing the Main Logic Board (Venturis FX Short Tower Only)

If you plan on replacing your computer's battery or installing an optional WaveTable daughter card (Venturis FXsm only), you need to remove the main logic board. To remove the main logic board:

1. Turn off your computer and monitor.
2. Disconnect all external devices, ac power, and monitor power.



WARNING: Make sure you disconnect the power cords from the computer and monitor or the power cords from the power outlets. When only the front panel switches are turned off, dc logic voltage is still present.

3. Remove the outside cover.
4. Pull up on the two latches attached to the main logic board.
This separates the main logic board from the backplane.
5. Carefully remove the main logic board from the chassis.

Replacing the Main Logic Board (Venturis FX Short Tower Only)

Replace the main logic board as follows:

1. Carefully slide the main logic board into the chassis.

Make sure the main logic board completely engages the backplane and the two latches fully lock into place.

2. Replace the outside cover.
3. Connect all external devices, ac power, and monitor power.

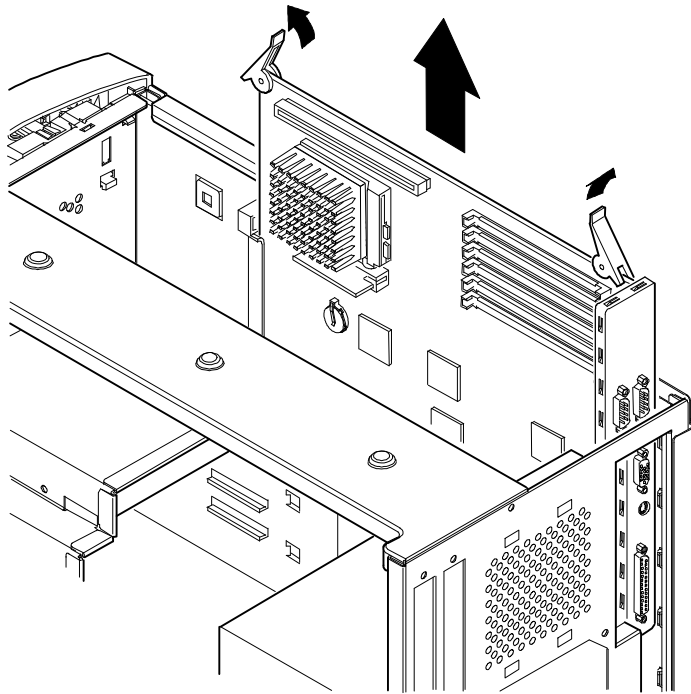

DEC0082

Figure 3-10. Removing the Main Logic Board (Venturis FX Short Tower Only)

Replacing the Lithium Battery

Your computer comes with a Lithium 3 V dc wafer-style battery. If your computer ever fails to retain the correct date, time, or configuration settings when it is turned on, you need to replace the installed battery. At other times, the battery just dies and needs to be replaced.

To replace the Lithium battery, perform the following:

1. If your battery is not dead, record your computer's configuration settings using the BIOS Setup utility.
2. Turn off your computer and monitor.
3. Disconnect all external devices, ac power, and monitor power.
4. If your computer is a short tower, remove the main logic board.
Refer to "Removing the Main Logic Board" in this chapter.
If your computer is a low profile, go to step 5.
5. Remove the outside cover.

6. Carefully lift up on the retaining clip just enough to slide the battery out as you push up on the battery from the side.



WARNING: There is a danger of battery explosion if a lithium battery is incorrectly replaced. To prevent damage to your computer, be sure the + side faces up when installing a new battery. Also, be sure you replace the battery with either a Digital (P/N 12-41474-05), Toshiba (P/N CR2032), or equivalent 3 V dc lithium battery.

Depending on your locality, your computer's battery might be considered hazardous waste. Make sure you follow any state or local statute to properly dispose of the old battery.

7. Install the new battery.

When installing the new battery, make sure the "+" side faces up.

8. If your computer is a short tower, replace the main logic board.
9. Replace the outside cover.
10. Connect all external devices and restore power.

If you were able to record the configuration settings or if you kept a record of the settings you changed, run the BIOS Setup utility to reconfigure your computer with the previous settings. Otherwise, use the defaults.

Refer to Chapter 2, "Using the BIOS Setup Utility."

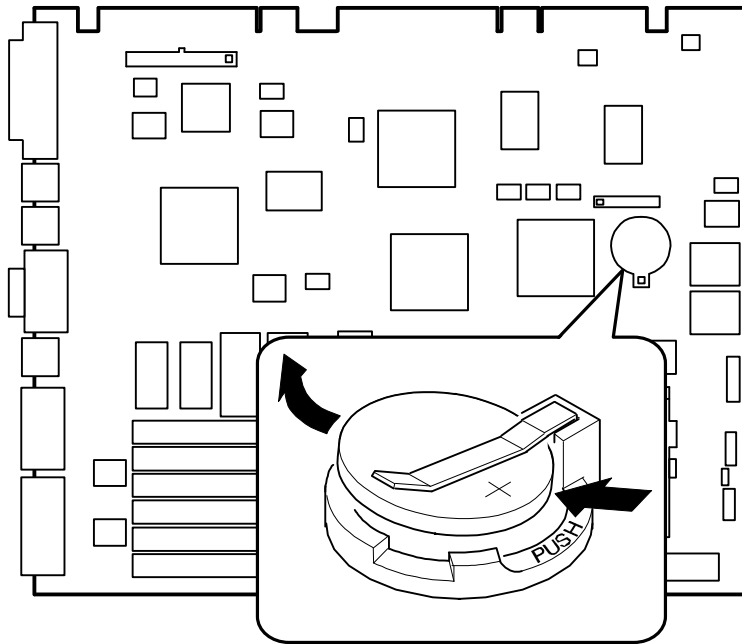

DEC00752-8

Figure 3-11. Replacing the Battery

Installing a Higher Performance Processor

Your computer comes with an Intel Pentium processor installed in a ZIF socket. Contact your Digital sales representative or reseller for future processor upgrade availability and ordering information for your computer.

To install a higher performance processor:

1. Turn off your computer and monitor and then disconnect all external devices, monitor power, and ac power.
2. Remove the outside cover.
3. Using a small screwdriver, release the retaining clip on the heat sink.
Use caution so as to avoid damaging the main logic board.
4. Lift the lever up and out to release the heat sink with the processor attached.
5. Separate the heat sink from the processor.
6. Install the new processor.



NOTE: Some processors might require a voltage regulator, other than the one that came with your computer, to operate correctly. Contact your computer sales representative for more information.

Make sure pin 1 on the processor is aligned with pin 1 on the ZIF socket (A, Figure 3-12).

Once the new processor is in place, return the release lever to its original position.

7. Clean the bottom of the heat sink with a clean cloth dampened with isopropyl alcohol.
8. Spread a smooth thin coat of thermal compound on the bottom of the heat sink.



CAUTION: Make sure the coating is thin enough so the thermal compound does not ooze out.

9. Install the heat sink on the processor and then replace the heat sink clip to secure the heat sink.
10. Set all appropriate processor jumpers on the main logic board.
Refer to Appendix A, "Technical Specifications," for jumper locations.
11. Replace the outside cover, reconnect all external devices, and then restore power.

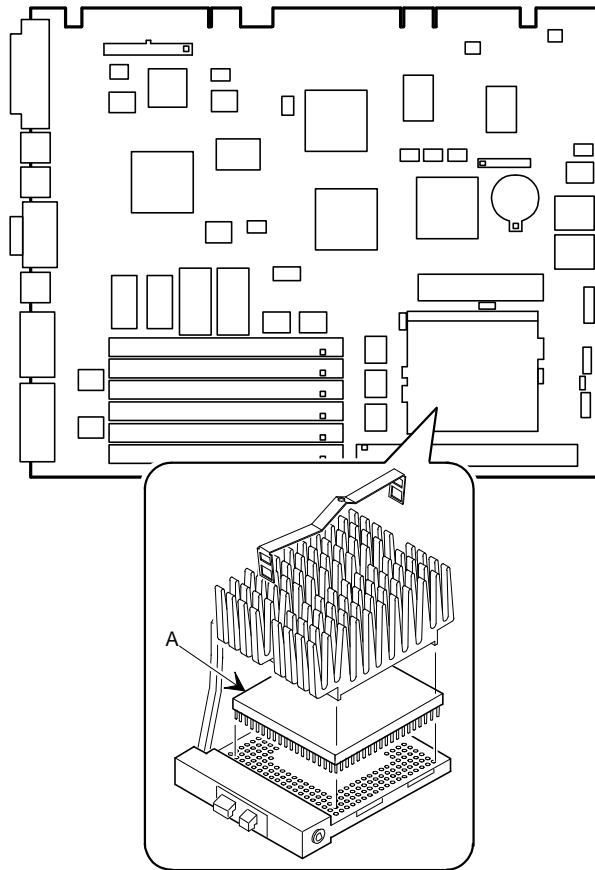

DEC00752-9

Figure 3-12. Installing a Higher Performance Processor

Installing a Processor VRM

If your Venturis FX or Celebris FX computer came with a 100 MHz processor, it also came with a shunt installed. If you want to upgrade your processor to 166 MHz or 200 MHz, you must remove the shunt and replace it with an industry-standard VRM.



NOTE: Processors requiring a VRM module change over time. At the time this guide was released, 166 MHz and 200 MHz processors require a VRM module.

To install an industry-standard VRM:

1. Turn off your computer and monitor.
2. Disconnect all external devices, ac power, and monitor power.
3. Remove the outside cover.
4. Carefully remove the shunt.
5. Install the VRM voltage regulator.

Make sure the socket on the voltage regulator is aligned with the pins on the main logic board connector.

6. Replace the outside cover.
7. Connect all external devices and restore power.

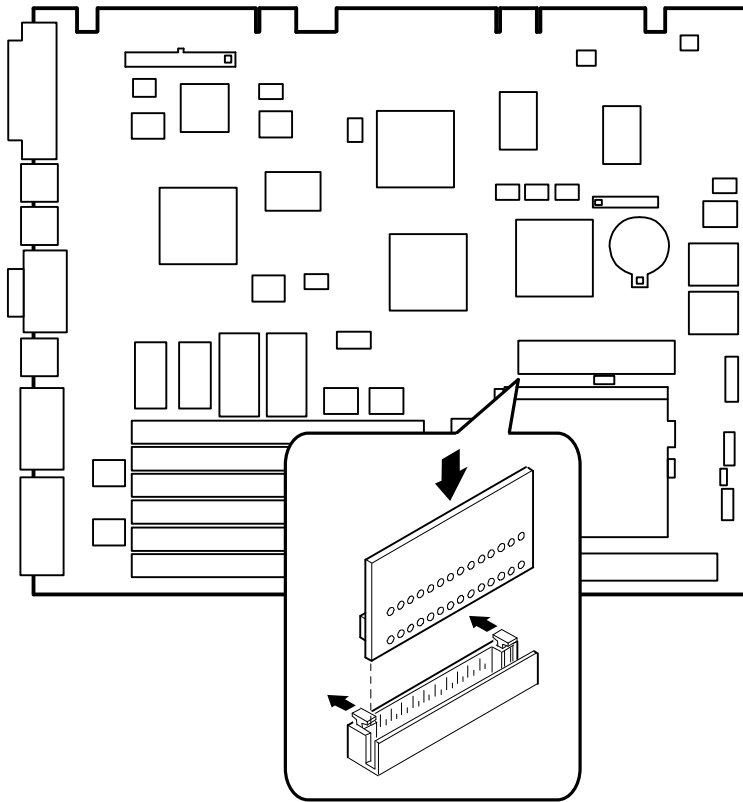

DEC00752-12

Figure 3-13. Installing a VRM

Main Logic Board Expansion

4

Introduction

This chapter provides detailed instructions on installing the following main logic board options:

- Computer memory
- Secondary cache module
- Video memory
- Optional WaveTable daughter card (Venturis FXsm only)

Refer to Chapter 1, "Beyond Quick Setup," information on removing and replacing your computer's outside cover.

Installing Additional Computer Memory

Adding more memory enables your computer to run larger, more complicated software and run it more quickly.

Depending on the model you purchased, your computer comes with either 8 MB or 16 MB of Extended Data Out (EDO) memory. For those with 8 MB computers, memory is installed as two 4 MB SIMMs in bank 0 (socket J11 and J12). For those with 16 MB computers, memory is installed as two 8 MB SIMMs in bank 0 (socket J11 and J12). When adding memory, you need to use 72-pin SIMMs (Figure 4-1).

Main Logic Board Expansion

For some models, you can increase this amount up to a maximum of 128 MB using the four SIMM sockets on the main logic board. All other models, including all models of the Celebris FX, can be increased up to 192 MB using the six SIMM sockets on the main logic board.

All Venturis FX and Celebris FX computers support EDO memory. EDO memory, in pairs of 4 MB, 8 MB, 16 MB, and 32 MB SIMMs, is faster than standard non-parity or Fast Page memory. Contact your local Digital sales representative for ordering information.

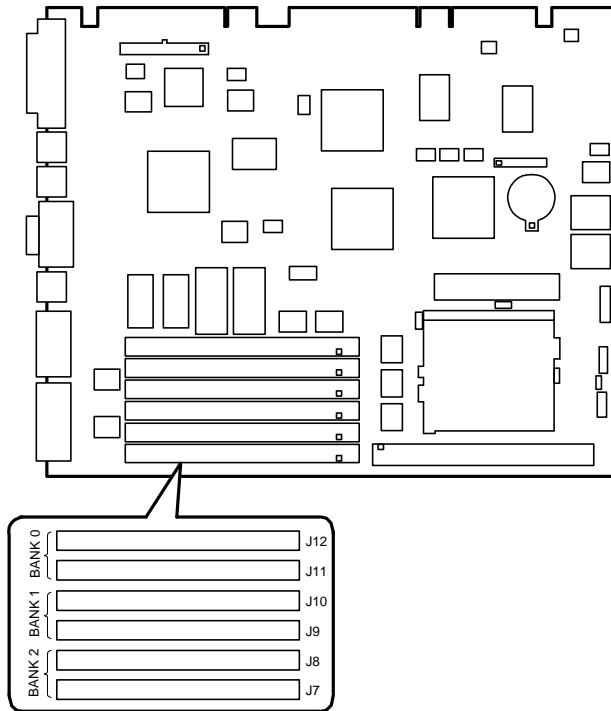

DEC00752-5

**Figure 4-1. SIMM Socket Locations for Most Models
(Some Models Have 4 SIMM Sockets)**

When adding SIMMs make sure you:

- Install 32-bit SIMMs having an access time of 70 ns or less. Supported SIMM sizes: 4 MB, 8 MB, 16 MB or 32 MB (60 ns for EDO DRAM).
- Although you can add a single SIMM of memory, for maximum performance you should populate both SIMM sockets in a given bank.
- If you populate both SIMM sockets in a given bank, you must use the same type and size memory. For example, if you add 8 MB of EDO memory in socket 3 (J10), and decide to add another 8 MB, you must use 8 MB of EDO memory in socket 4 (J9).
- You can mix EDO and fast paged memory, but not in the same bank.

Refer to "Memory Configurations" for a list of SIMM combinations supported by your Venturis FX and Celebris FX computer and to "Installing a SIMM" for detailed instructions on installing SIMMs.

Memory Configurations

Socket J12	Socket J11	Socket J10	Socket J9	Socket ⁽¹⁾ J8	Socket ⁽¹⁾ J7	Total
4 MB	4 MB					8 MB
4 MB	4 MB	4 MB				12 MB
4 MB	4 MB	8 MB				16 MB
4 MB	4 MB	16 MB				24 MB
4 MB	4 MB	32 MB				40 MB
4 MB	4 MB	4 MB	4 MB			16 MB
4 MB	4 MB	4 MB	4 MB	4 MB		20 MB
4 MB	4 MB	4 MB	4 MB	8 MB		24 MB
4 MB	4 MB	4 MB	4 MB	16 MB		32 MB
4 MB	4 MB	4 MB	4 MB	32 MB		48 MB
4 MB	4 MB	8 MB	8 MB			24 MB
4 MB	4 MB	16 MB	16 MB			40 MB
4 MB	4 MB	32 MB	32 MB			72 MB
8 MB						8 MB
8 MB	8 MB					16 MB
8 MB	8 MB	4 MB				20 MB
8 MB	8 MB	8 MB				24 MB
8 MB	8 MB	16 MB				32 MB
8 MB	8 MB	32 MB				48 MB
8 MB	8 MB	8 MB	8 MB			32 MB
8 MB	8 MB	8 MB	8 MB	4 MB		36 MB
8 MB	8 MB	8 MB	8 MB	8 MB		40 MB
8 MB	8 MB	8 MB	8 MB	16 MB		48 MB
8 MB	8 MB	8 MB	8 MB	32 MB		64 MB
8 MB	8 MB	8 MB	8 MB	8 MB	8 MB	48 MB
8 MB	8 MB	8 MB	8 MB	16 MB	16 MB	64 MB
8 MB	8 MB	8 MB	8 MB	32 MB	32 MB	96 MB
8 MB	8 MB	16 MB	16 MB			48 MB
8 MB	8 MB	16 MB	16 MB	4 MB		52 MB
8 MB	8 MB	16 MB	16 MB	8 MB		56 MB
8 MB	8 MB	16 MB	16 MB	16 MB		64 MB
8 MB	8 MB	16 MB	16 MB	32 MB		80 MB
8 MB	8 MB	16 MB	16 MB	8 MB	8 MB	64 MB
8 MB	8 MB	16 MB	16 MB	16 MB	16 MB	80 MB
8 MB	8 MB	16 MB	16 MB	32 MB	32 MB	112 MB
8 MB	8 MB	32 MB	32 MB			80 MB
8 MB	8 MB	32 MB	32 MB	4 MB		84 MB
8 MB	8 MB	32 MB	32 MB	8 MB		88 MB

(1) Sockets not installed on some models

continued

Main Logic Board Expansion

Socket J12	Socket J11	Socket J10	Socket J9	Socket J8 ⁽¹⁾	Socket J7 ⁽¹⁾	Total
8 MB	8 MB	32 MB	32 MB	16 MB		96 MB
8 MB	8 MB	32 MB	32 MB	32 MB		112 MB
8 MB	8 MB	32 MB	32 MB	8 MB	8 MB	96 MB
8 MB	8 MB	32 MB	32 MB	16 MB	16 MB	112 MB
16 MB						16 MB
16 MB	16 MB					32 MB
16 MB	16 MB	4 MB				36 MB
16 MB	16 MB	8 MB				40 MB
16 MB	16 MB	16 MB				48 MB
16 MB	16 MB	32 MB				64 MB
16 MB	16 MB	8 MB	8 MB			48 MB
16 MB	16 MB	8 MB	8 MB	4 MB		52 MB
16 MB	16 MB	8 MB	8 MB	8 MB		56 MB
16 MB	16 MB	8 MB	8 MB	16 MB		64 MB
16 MB	16 MB	8 MB	8 MB	32 MB		80 MB
16 MB	16 MB	8 MB	8 MB	8 MB	8 MB	64 MB
16 MB	16 MB	8 MB	8 MB	16 MB	16 MB	80 MB
16 MB	16 MB	8 MB	8 MB	32 MB	32 MB	112 MB
16 MB	16 MB	16 MB	16 MB			64 MB
16 MB	16 MB	16 MB	16 MB	4 MB		68 MB
16 MB	16 MB	16 MB	16 MB	8 MB		72 MB
16 MB	16 MB	16 MB	16 MB	16 MB		80 MB
16 MB	16 MB	16 MB	16 MB	32 MB		96 MB
16 MB	16 MB	16 MB	16 MB	8 MB	8 MB	80 MB
16 MB	16 MB	16 MB	16 MB	16 MB	16 MB	96 MB
16 MB	16 MB	16 MB	16 MB	32 MB	32 MB	128 MB
16 MB	16 MB	32 MB	32MB			96 MB
16 MB	16 MB	32 MB	32MB	4 MB		100 MB
16 MB	16 MB	32 MB	32MB	8 MB		104 MB
16 MB	16 MB	32 MB	32MB	16 MB		112 MB
16 MB	16 MB	32 MB	32MB	32 MB		128 MB
16 MB	16 MB	32 MB	32MB	8 MB	8 MB	112 MB
16 MB	16 MB	32 MB	32MB	16 MB	16 MB	128 MB
32 MB						32 MB
32 MB	32 MB					64 MB
32 MB	32 MB	4 MB				68 MB
32 MB	32 MB	8 MB				72 MB

(1) Sockets not installed on some models

continued

Main Logic Board Expansion

Socket J12	Socket J11	Socket J10	Socket J9	Socket J8 ⁽¹⁾	Socket J7 ⁽¹⁾	Total
32 MB	32 MB	16 MB				80 MB
32 MB	32 MB	32 MB				96 MB
32 MB	32 MB	8 MB	8 MB			80 MB
32 MB	32 MB	8 MB	8 MB	4 MB		84 MB
32 MB	32 MB	8 MB	8 MB	8 MB		88 MB
32 MB	32 MB	8 MB	8 MB	16 MB		96 MB
32 MB	32 MB	8 MB	8 MB	32 MB		112 MB
32 MB	32 MB	8 MB	8 MB	8 MB	8 MB	96 MB
32 MB	32 MB	8 MB	8 MB	16 MB	16 MB	112 MB
32 MB	32 MB	16 MB	16 MB			96 MB
32 MB	32 MB	16 MB	16 MB	4 MB		100 MB
32 MB	32 MB	16 MB	16 MB	8 MB		104 MB
32 MB	32 MB	16 MB	16 MB	16 MB		112 MB
32 MB	32 MB	16 MB	16 MB	32 MB		128 MB
32 MB	32 MB	16 MB	16 MB	8 MB	8 MB	112 MB
32 MB	32 MB	32 MB	32 MB			128 MB
32 MB	32 MB	32 MB	32 MB	4 MB		132 MB
32 MB	32 MB	32 MB	32 MB	8 MB		136 MB
32 MB	32 MB	32 MB	32 MB	16 MB		144 MB
32 MB	32 MB	32 MB	32 MB	32 MB		160 MB
32 MB	32 MB	32 MB	32 MB	8 MB	8 MB	144 MB
32 MB	32 MB	32 MB	32 MB	16 MB	16 MB	160 MB
32 MB	32 MB	32 MB	32 MB	32 MB	32 MB	196 MB

⁽¹⁾ Sockets not installed on some models

Installing a SIMM

To install a SIMM, perform the following:

1. Turn off your computer and monitor.
2. Disconnect all external devices, ac power, and monitor power.
3. Remove the outside cover.
4. Install the SIMM into the socket at a 45 degree angle.

Make sure the notch is oriented as shown (A, Figure 4-2). Rock the SIMM gently until it completely engages the bottom of the socket. Tip the SIMM upright until both retaining clips engage (B, C, Figure 4-2).

5. Replace the outside cover.
6. Connect all external devices and restore power.

Main Logic Board Expansion

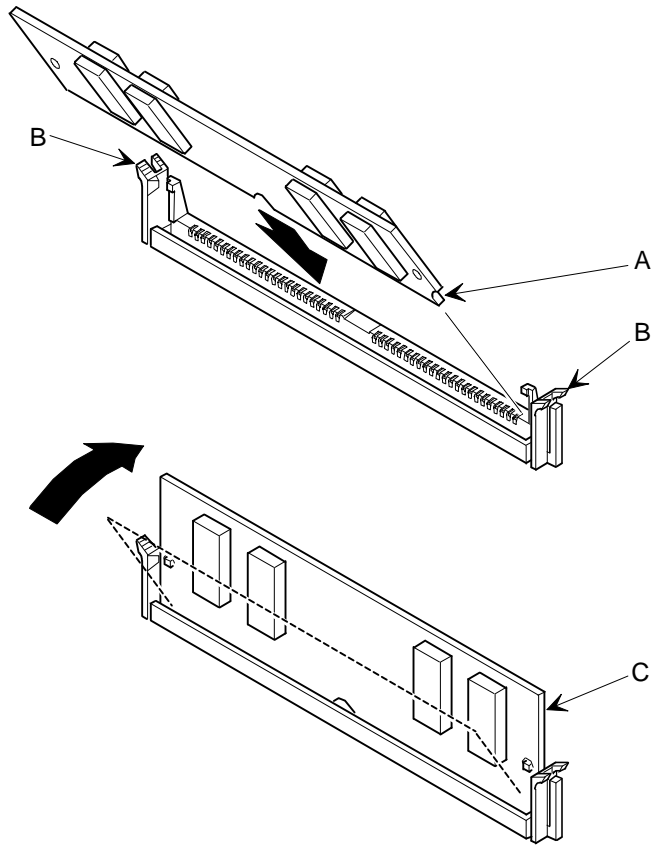

DEC00921

Figure 4-2. Installing a SIMM

Installing a Secondary Cache Module

Most Venturis FX and Celebris FX models come with a 256 KB pipeline burst secondary cache module. The module is installed in an upgradeable socket on the main logic board. Cache enhances the overall performance of your computer by increasing data throughput.

You can upgrade to a 512 KB secondary cache module by replacing the existing 256 KB cache module. If your computer did not come with a 256 KB cache, you can upgrade to either a 256 KB or 512 KB secondary cache module. When purchasing a secondary cache module upgrade, make sure it is COAST standard.



NOTE: If you have 64 MB or more of memory installed in your computer, it is recommended that you install a 512 KB secondary cache to maximize your computer's performance.

To install a secondary cache module, perform the following:

1. Turn off your computer and monitor.
2. Disconnect all external devices, ac power, and monitor power.
3. Remove the outside cover.
4. Is the cache socket on your Digital FX computer populated?
 - a. If yes, hold the 256 KB cache module by its top edge and carefully lift it out. Make sure you lift it away from main logic board.
Put the cache module in an antistatic package for safekeeping.
 - b. If no, proceed to step 5.
5. Holding the upgrade secondary cache module only by its top edge, carefully insert it into the socket on the main logic board.
Make sure it fully seats into socket.

Main Logic Board Expansion

6. Replace the outside cover.
7. Connect all external devices and restore power.

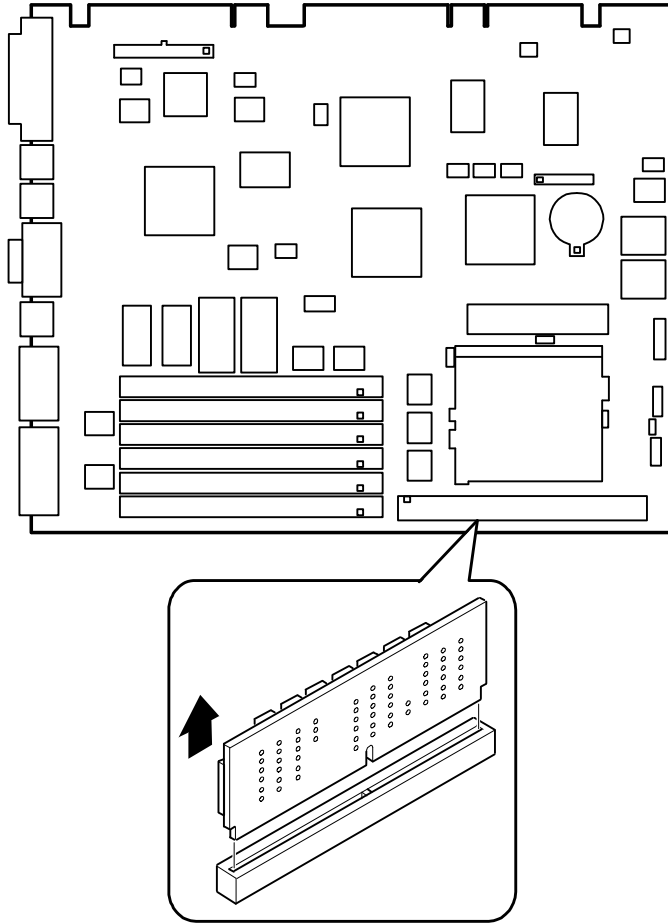

DEC00752-7

Figure 4-3. Installing a Secondary Cache Module

Installing Video Memory

On some computers, you can upgrade to 2 MB of video memory by installing two industry standard EDO 40-pin 256 KB x 16 50 ns video memory DRAM chips. To install the video memory upgrade chips:

1. Turn off your computer and monitor.
2. Disconnect all external devices, ac power, and monitor power.
3. Remove the outside cover.
4. Install each video memory DRAM chip.



CAUTION: Make sure pin 1 on each video DRAM chip is correctly aligned with the location on the socket (A, Figure 4-4). Incorrect installation can cause faulty computer operation.

5. Replace the outside cover.
6. Connect all external devices and restore power.

Main Logic Board Expansion

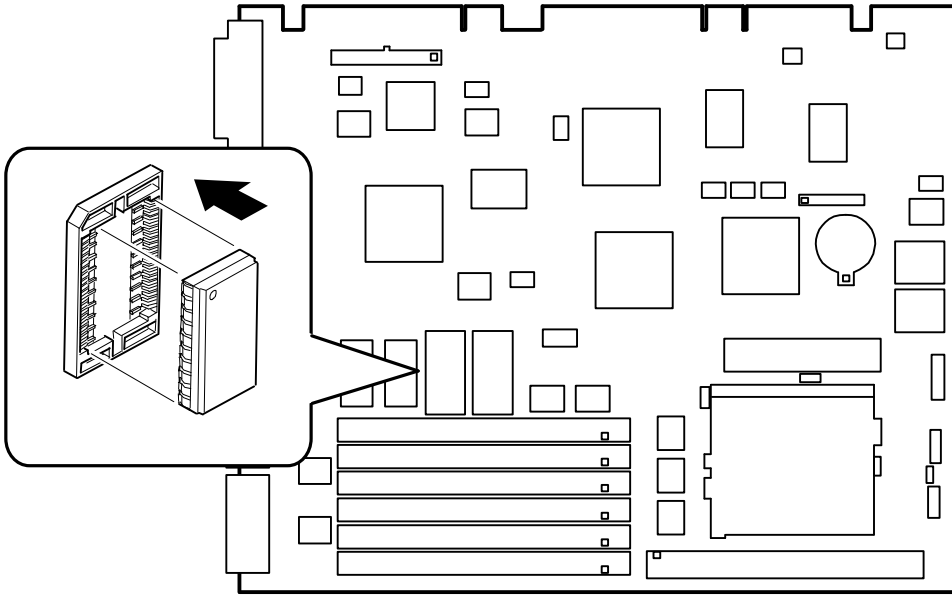

DEC00752-6

Figure 4-4. Video Memory Installation

Installing an Optional WaveTable Daughter Card (Venturis FXsm Only)

If your computer comes with onboard audio, you can install an optional WaveTable daughter card to enhance your computer's audio capabilities by providing life-like sound based on actual recordings of real instruments. This daughter card is specifically designed and manufactured by Digital for use in Venturis FXsm multimedia computers. To order this option, contact your computer sales representative.

To install an optional WaveTable daughter card:

1. Turn off your computer and monitor.
2. Disconnect all external devices, ac power, and monitor power.
3. Remove the outside cover.
4. Remove the main logic board (refer to Chapter 3)
5. Install the WaveTable daughter card.



CAUTION: Make sure pin 1 on the WaveTable daughter card is correctly aligned with the location on the socket (A, Figure 4-5). Incorrect installation can cause faulty computer operation.

6. Replace the main logic board (refer the Chapter 3).
7. Replace the outside cover.

Main Logic Board Expansion

8. Connect all external devices and restore power.
9. Install the supplied software that came with the WaveTable daughter card option.

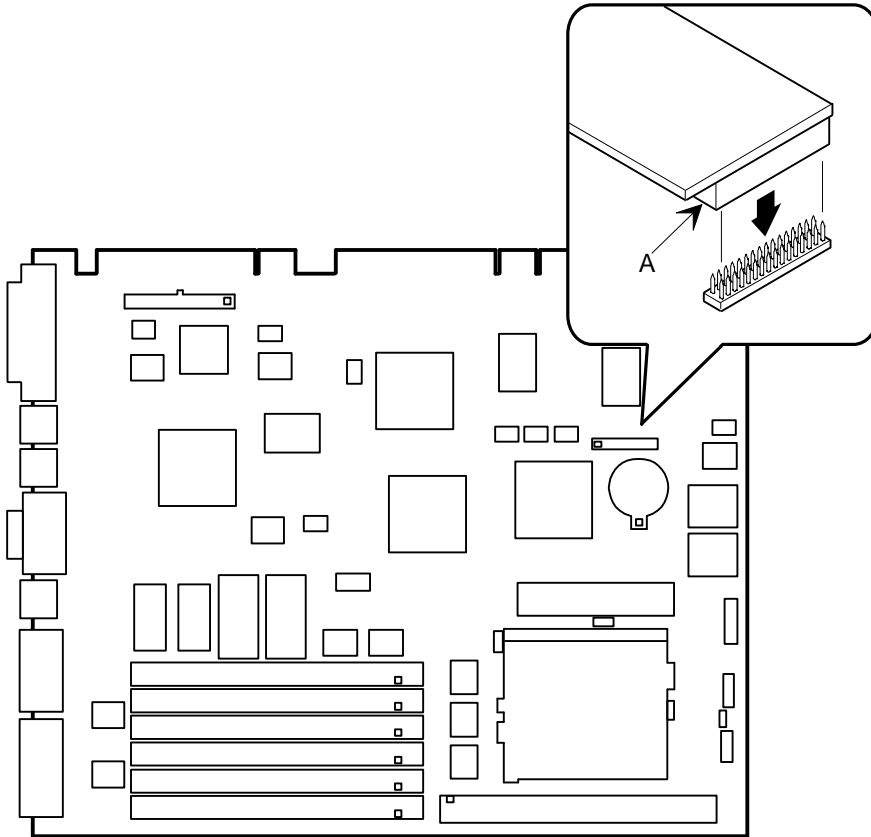

DEC00752-11

Figure 4-5. Wave Table Expansion Board Installation (Venturis FXsm Only)

Adding Expansion Boards **5**

Introduction

For all Venturis FX and Celebris FX computers, expansion slots are located on a backplane. This chapter describes the location of these slots and provides detailed instructions on installing ISA and PCI expansion boards.

Configuring Expansion Slots

If you are a Windows 95 user, your computer automatically assigns the necessary resources to any installed Plug and Play-compatible expansion board so it operates at maximum performance. Plug and Play technology eliminates the process of manually configuring optional expansion boards for operation in your computer. With Plug and Play expansion boards, and a Plug and Play operating system, such as Windows 95, your computer's BIOS, operating system, and hardware logic work together to assign automatically interrupt requests (IRQs), I/O and memory addresses, and DMA channels for optimum performance.

If you plan on installing non-Plug and Play expansion boards or legacy boards or if you are using a non-Plug and Play operating system, such as Windows NT Workstation, you might need to set jumpers manually based on the computer resources already allocated. Your computer does not automatically assign the necessary resources for any non-Plug and Play or legacy expansion board or if you are using a non-Plug and Play operating system.

To help you determine what settings to use on legacy boards or with Windows NT Workstation, there is an ISA Configuration Utility (ICU). In Windows 95, the ICU is built into Windows 95. With Windows NT Workstation, use the bootable ICU diskette.

Expansion Slots (Venturis FX and Celebris FX Low Profile)

Your Venturis FX and Celebris FX low profile backplane contains four slots for installing:

- Two ISA expansion boards and one PCI expansion board or
- One ISA expansion board and two PCI expansion boards (refer to the table).

Expansion Slot Designation	Description
ISA2	Supports half-length industry-standard 16-bit ISA expansion boards Uses the top expansion slot at the rear panel
PCI2	Supports half-length 32-bit PCI local bus expansion boards Uses the middle expansion slot at the rear panel Designated as a shared slot with ISA slot ISA1 ⁽¹⁾
ISA1	Supports full-length industry-standard 16-bit ISA expansion boards Uses the middle expansion slot at the rear panel Designated as a shared slot with PCI slot PCI2 ⁽¹⁾
PCI1	Supports full-length 32-bit PCI local bus expansion boards Uses the bottom expansion slot at the rear panel

⁽¹⁾ Only one expansion board can reside in slot PCI2 and ISA1 at any one time. These slots have to share the middle expansion slot opening at the rear panel, thus, a maximum of three expansion boards can be supported at any one time.

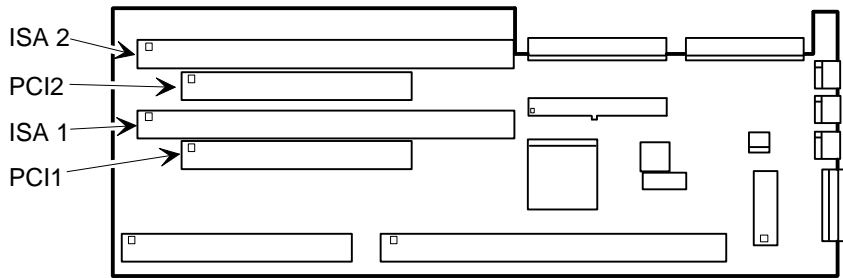

DEC00753-3

Figure 5-1. Expansion Board Slots (Venturis FX and Celebris FX Low Profile)

Expansion Slots (Venturis FX Short Tower)

Your Venturis FX short tower backplane contains six slots for installing:

- Four ISA expansion boards and one PCI expansion board or
- Three ISA expansion boards and two PCI expansion boards (refer to the table).

Expansion Slot Designation	Description
ISA2-ISA4	Supports full-length industry-standard 16-bit ISA expansion boards Uses the first, second, and third (bottom three) expansion slots at the rear panel
PCI2	Supports full-length 32-bit PCI local bus expansion boards Uses the fourth expansion slot at the rear panel Designated as a shared slot with ISA slot ISA1 ⁽¹⁾
ISA1	Supports half-length industry-standard 16-bit ISA expansion boards Uses the fourth expansion slot at the rear panel Designated as a shared slot with PCI slot PCI2 ⁽¹⁾
PCI1	Supports half-length 32-bit PCI local bus expansion boards Uses the fifth (top) expansion slot at the rear panel

⁽¹⁾ Only one expansion board can reside in slot PCI2 and ISA1 at any one time. These slots have to share the third expansion slot opening at the rear panel, thus, a maximum of five expansion boards can be supported at any one time.

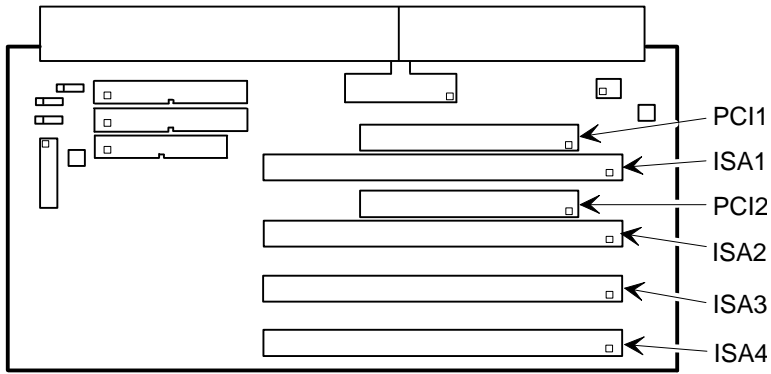

DEC00754-3

Figure 5-2. Expansion Board Slots (Venturis FX Short Tower)

Installing Expansion Boards

To install an ISA or PCI local bus expansion board:



NOTE: If you are running a non-Plug and Play operating system, such as Windows NT Workstation or a non-Plug and Play expansion board, run the ICU before installing your expansion board. The ICU can help you to determine what settings to use to determine what configuration the ICU recommends. Configure any jumpers on the expansion board and then install the expansion board. Next install any device drivers for the expansion board.

Refer to the expansion board's documentation for more information.

1. Turn off your computer and monitor.
2. Disconnect all external devices, ac power, and monitor power.
3. Remove the outside cover.
4. For short tower models, you can rotate the disk drives to make the area more accessible.

5. Unscrew the metal filler plate(s) from the selected expansion slot.

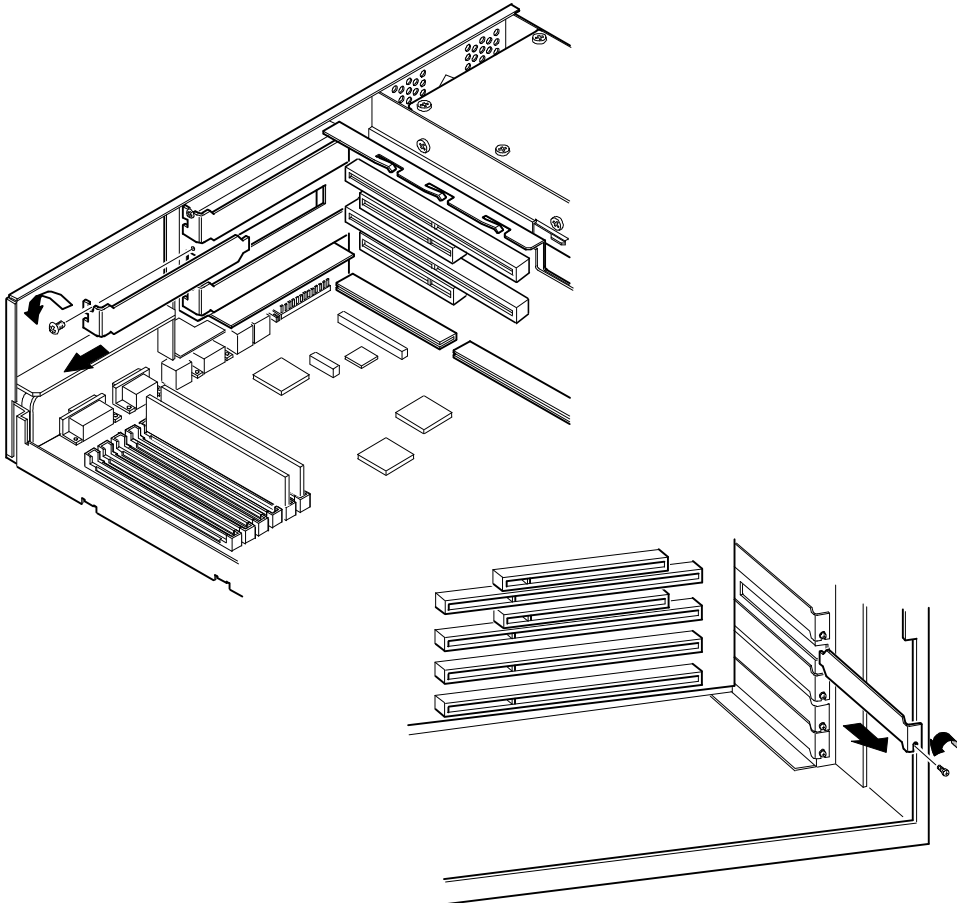

DEC00960-2

Figure 5-3. Removing a Metal Filler Plate

Adding Expansion Boards

6. Insert the new expansion board into the socket.
Push the expansion board firmly into place.
7. Secure the expansion board to the slot with the screw removed in step 4.
8. Replace the outside cover.
9. Connect all external devices and restore power.

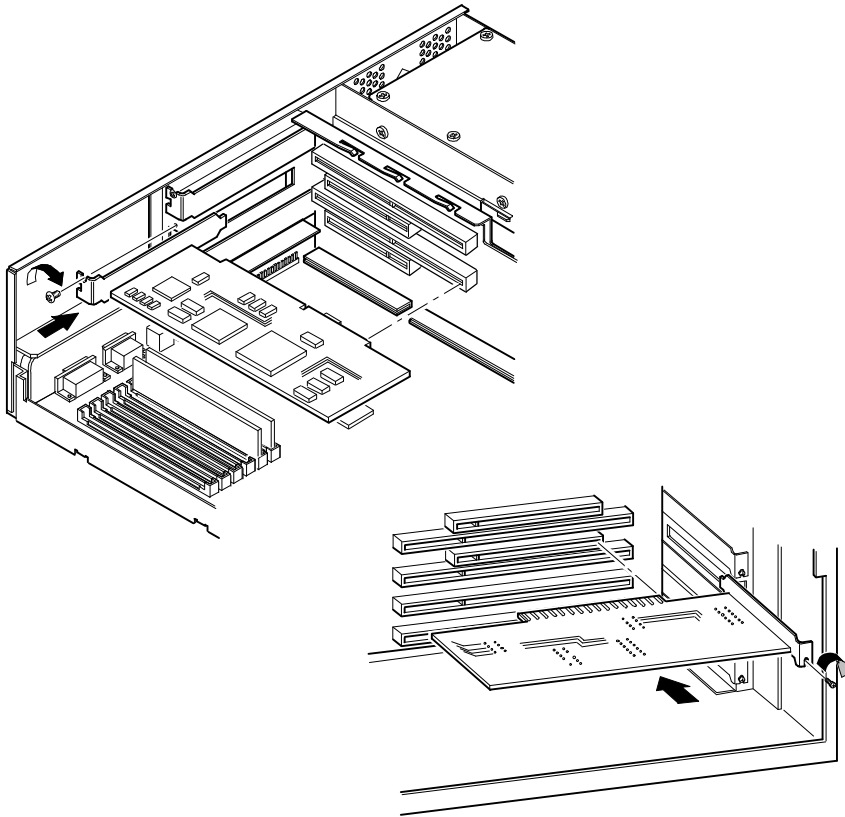

DEC00960-3

Figure 5-4. Installing an Expansion Board

Removing Expansion Boards

If you remove a legacy expansion board or remove an expansion board from a computer running Windows NT Workstation, run the ICU. Use the ICU bootable diskette with Windows NT Workstation. Windows 95 users removing legacy expansion boards can use the ICU that is integrated into Windows 95. You can then remove the expansion board from the ICU Configuration menu and thereby free up resources listed in the ICU database.

Adding Mass Storage Devices

6

Introduction

This chapter provides detailed information on installing mass storage devices, such as another hard disk drive, a tape drive, or another diskette drive. This chapter also describes how to connect diskette and IDE mass storage devices after installation. Note that these installation instructions are referenced as looking from the front of the computer to the rear.

Installing Mass Storage Devices (Venturis FX and Celebris FX Low Profile)

Your Venturis FX and Celebris FX low profile computer contains four mass storage device bays:

- The middle-front device bay contains a factory installed 3½-inch diskette drive.
- The top-right device bay contains a factory installed CD-ROM (not available on all models).
- The bottom-right device bay is accessible from the front of the computer and can hold a 3½-inch or 5¼-inch half-height device. For example, a diskette drive, tape backup drive, or hard disk drive.
- The rear device bay (on top of the power supply) is not accessible from the front of the computer. This bay contains a factory installed 3½-inch hard disk drive.

Installing Mass Storage Devices (Venturis FX Short Tower)

Your Venturis FX short tower computer contains six mass storage device bays:

- The top device bay contains a factory installed 3½-inch diskette drive.
- The second device bay contains a factory installed CD-ROM (not available on all models).
- The third and fourth device bays can hold a 5¼-inch half-height device. For example, a diskette drive, tape backup drive, or hard disk drive.
- The internal device bay is not accessible from the front of the computer and contains a factory installed, low-profile (1-inch high), 3½-inch hard disk drive. This device bay also has room to install a second low-profile (1-inch high), 3½-inch hard disk drive.

The following procedures and illustrations show a base computer configuration. Your specific drive bay configurations and storage devices might vary.

Installing a 3½-Inch Device into the Bottom-Right Device Bay (Venturis FX and Celebris FX Low Profile)

The following procedures describe how to install a 3½-inch device into the bottom-right device bay.



NOTE: Refer to the manufacturer's instructions for your device to determine if switches or jumper settings need to be set or installed on the device. Set all switch and jumper settings accordingly.

1. Turn off your computer and monitor.
2. Disconnect all external devices, ac power, and monitor power.
3. Remove the outside cover.
4. Remove the 5¼-inch EMI shield covering the bay.
5. Remove the drive rail from the inside of the chassis.

6. Install the brackets onto the 3½-inch device.

You might need to purchase the bracket. Call your computer supplier or vendor to help you order the part.

7. Install the drive rail.

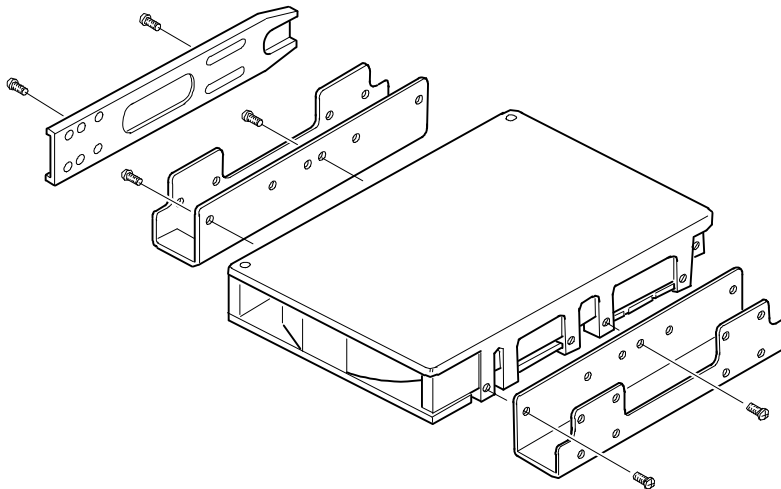

DEC00723

Figure 6-1. Installing Drive Rail and 3½-Inch Device Brackets (Venturis FX and Celebris FX Low Profile)

Adding Mass Storage Devices

- Carefully slide the 3½-inch device into the device bay.
Secure the device using the supplied mounting screws.

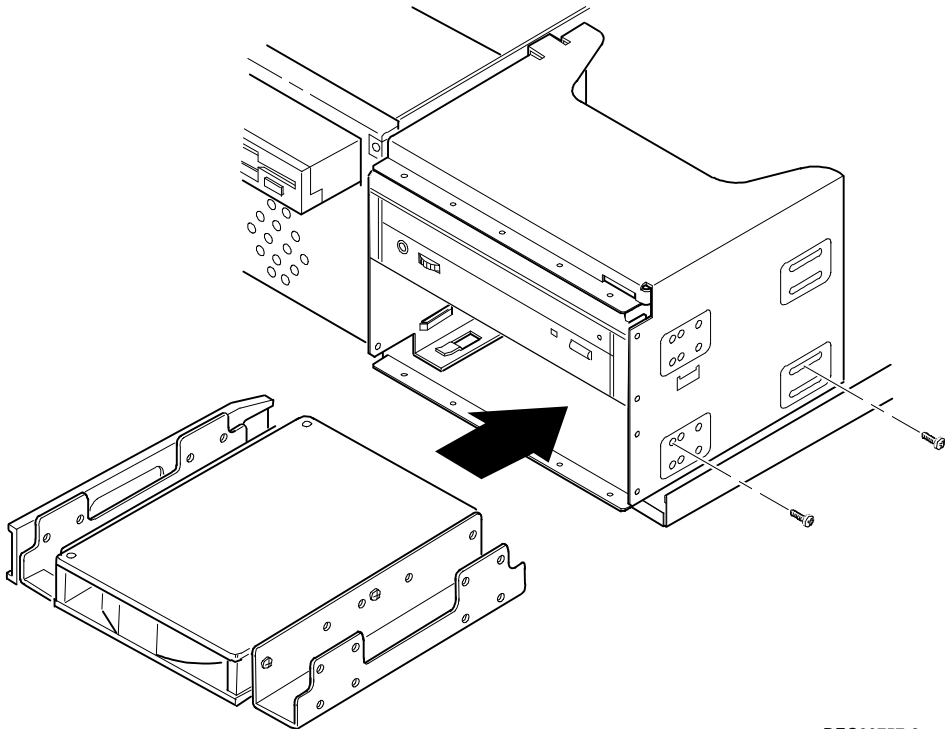

DEC00757-6

Figure 6-2. Installing a 3½-Inch Device (Venturis FX and Celebris FX Low Profile)

- If necessary, replace the filler panel.
- Connect the power and data cables to the 3½-inch device.
Refer to "Connecting Diskette and IDE Devices" later in this chapter.

Installing a 5¼-Inch Device into the Bottom-Right Device Bay (Venturis FX and Celebris FX Low Profile)

The following procedures describe how to install a 5¼-inch device into the bottom-right device bay.



NOTE: Refer to the manufacturer's instructions for your device to determine if switches or jumper settings need to be set or installed on the device. Set all switch and jumper settings accordingly.

1. Turn off your computer and monitor.
2. Disconnect all external devices, ac power, and monitor power.
3. Remove the outside cover.
4. If necessary, remove the filler panel from the front bezel and the 5¼-inch EMI shield.
5. Remove the drive rail from the inside of the chassis.

Adding Mass Storage Devices

6. Attach the drive rail onto the 5¼-inch device.
7. Using the attached drive rail and mounting screws, install the 5¼-inch device into the device bay.
8. If necessary, replace the filler panel.
9. Connect the power and data cables to the 5¼-inch device.

Refer to "Connecting Diskette and IDE Devices" later in this chapter.

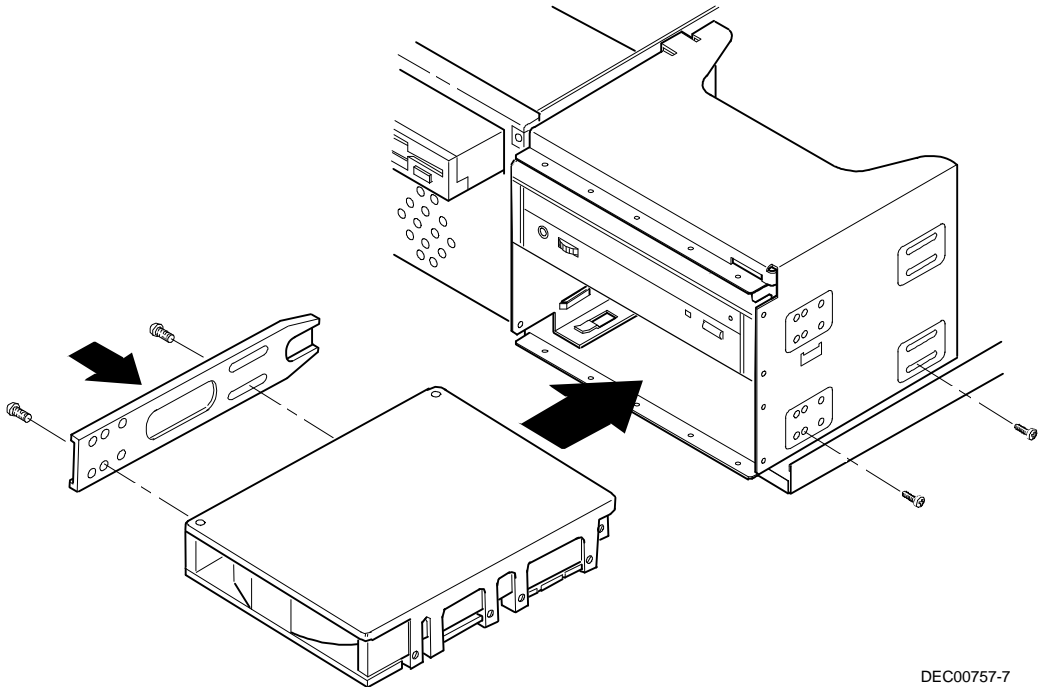

DEC00757-7

Figure 6-3. Installing a 5¼-Inch Device (Venturis FX and Celebris FX Low Profile)

Installing a 3½-Inch Device into a Front Device Bay (Venturis FX Short Tower)

The following procedures describe how to install 3½-inch device into a front-access device bay.



NOTE: Refer to the manufacturer's instructions for your device to determine if switches or jumper settings need to be set or installed on the device. Set all switch and jumper settings accordingly.

1. Turn off your computer and monitor.
2. Disconnect all external devices, ac power, and monitor power.
3. Remove the outside cover.
4. Remove the front bezel.
5. Remove the 5¼-inch EMI shield covering the bay.

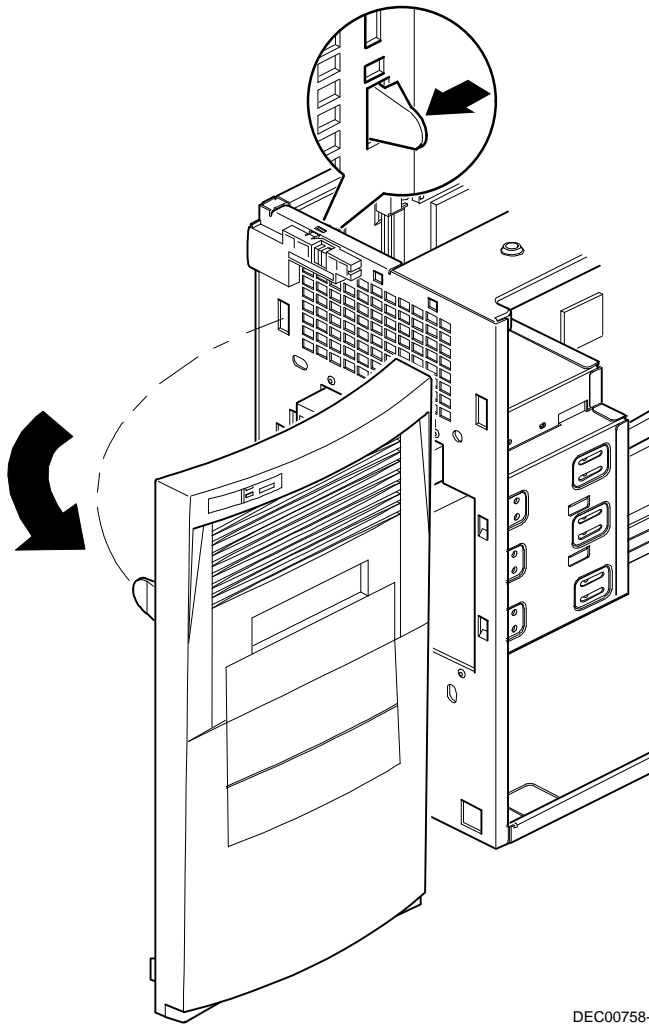

DEC00758-2

Figure 6-4. Removing the Front Bezel (Venturis FX Short Tower)

6. Install the brackets onto the 3½-inch device (see Figure 6-1).

You might need to purchase the bracket. Call your computer supplier or vendor to help you order the part.

7. Attach the drive rail.
8. Carefully slide the 3½-inch device into the device bay.
Secure the device using the supplied mounting screws.

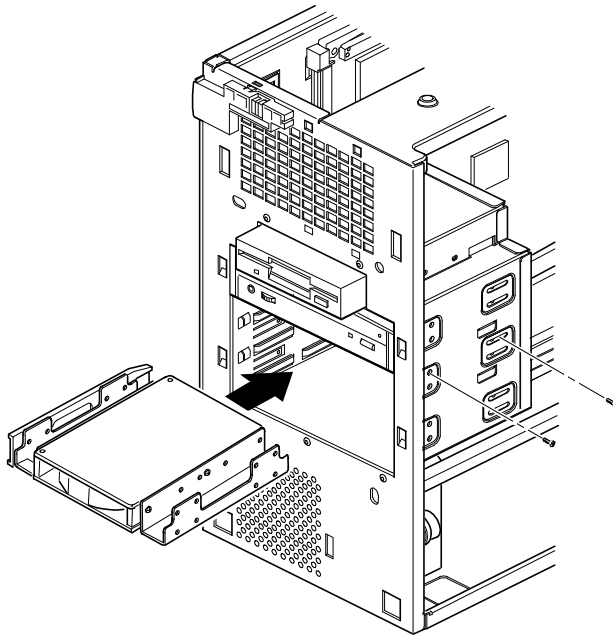

DEC00758-8

Figure 6-5. Installing a 3½-Inch Device (Venturis FX Short Tower)

9. Connect the power and data cables to the 3½-inch device.
Refer to "Connecting Diskette and IDE Devices" later in this chapter.

Installing a 5¼-Inch Device Into a Front Device Bay (Venturis FX Short Tower)

The following procedures describe how to install 5¼-inch device into a front-access device bay.



NOTE: Refer to the manufacturer's instructions for your device to determine if switches or jumper settings need to be set or installed on the device. Set all switch and jumper settings accordingly.

1. Turn off your computer and monitor.
2. Disconnect all external devices, ac power, and monitor power.
3. Remove the outside cover.
4. Remove the front bezel (see Figure 6-4).
5. If necessary, remove the filler panel from the front bezel and remove the 5¼-inch EMI shield.

6. Remove the drive rail from the inside of the chassis and attach it to the drive.
7. Using the supplied drive rail and mounting screws, install the 5¼-inch device into the appropriate device bay.

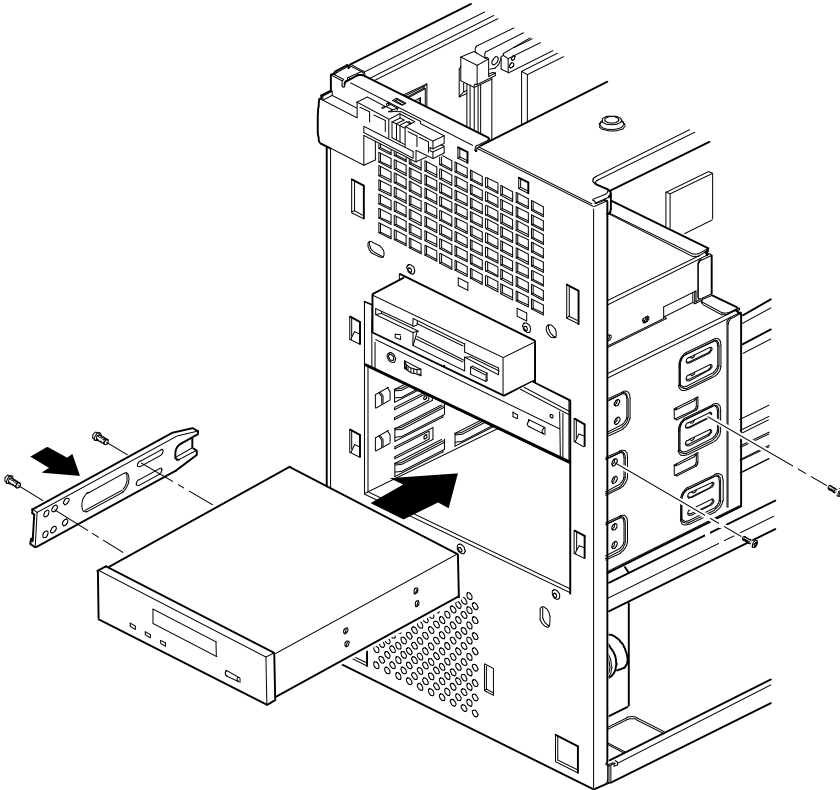

DEC00758-9

Figure 6-6. Installing 5¼-Inch Device (Venturis FX Short Tower)

8. Connect the power and data cables to the 5¼-inch device.
Refer to "Connecting Diskette and IDE Devices" later in this chapter.

Installing a 3½-Inch Device into the Internal Device Bay (Venturis FX Short Tower)

The following procedures describe how to install a low profile, 1-inch high, 3½-inch mass storage device into the internal device bay.



NOTE: Refer to the manufacturer's instructions for your mass storage device to determine if switches or jumper settings need to be set or installed on the device. Set all switch or jumper settings accordingly.

1. Turn off your computer and monitor.
2. Disconnect all external devices, ac power, and monitor power.
3. Remove the outside cover.
4. Disconnect the data and power cables from the installed hard disk drive.
Refer to "Connecting Diskette and IDE Devices" later in this chapter.
5. Remove the two screws securing the device bay to the chassis.
6. Swing the device bay away from the chassis to gain access to the upper bay.

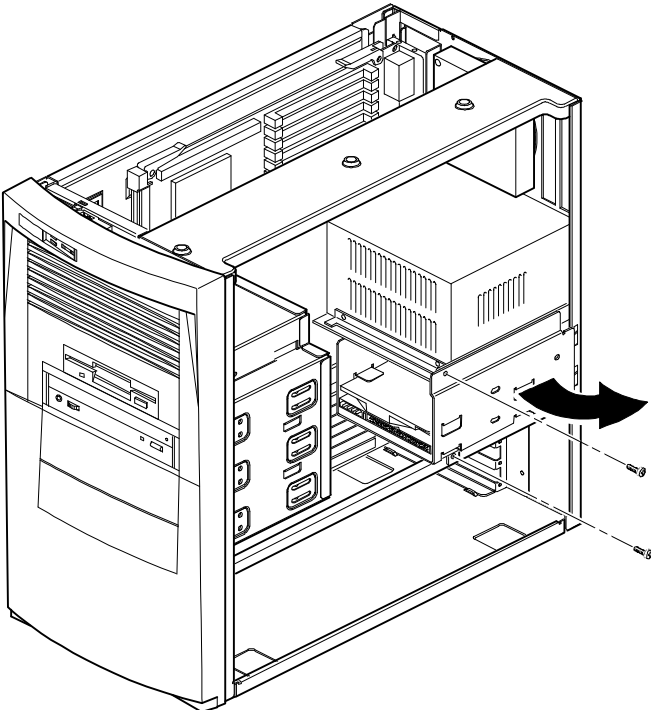

DEC00759-2

Figure 6-7. Accessing the Internal 3 1/2-Inch Device Bay (Venturis FX Short Tower)

Adding Mass Storage Devices

7. Attach the 3½-inch device to the internal 3½-inch device bay.
Secure the device using the supplied mounting screws.

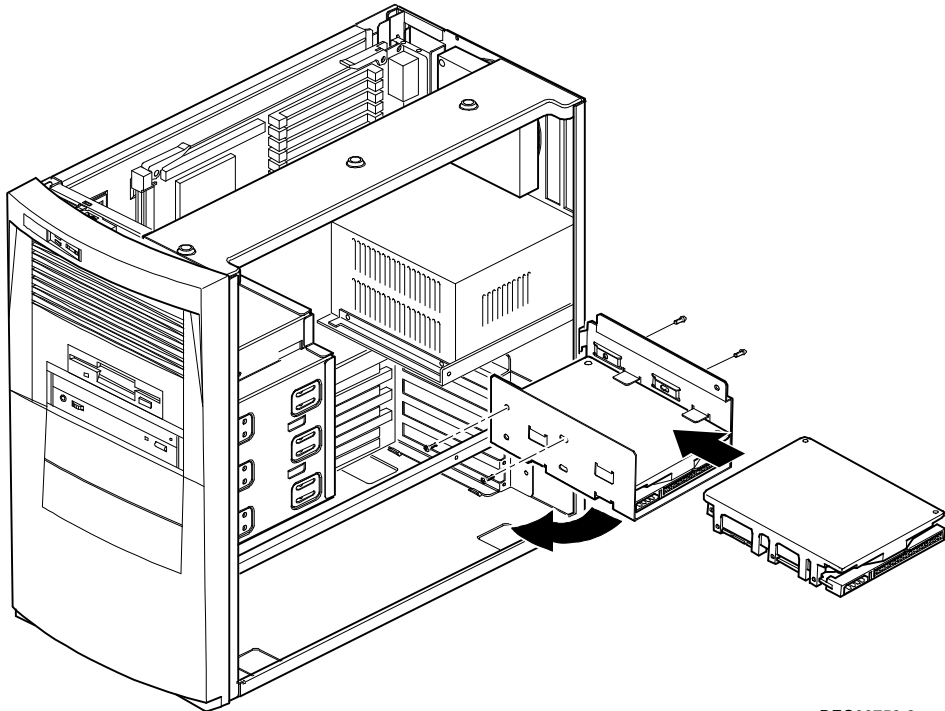

DEC00759-3

Figure 6-8. Attaching a 3½-Inch Device to the Internal 3½-inch Device Bay (Venturis FX Short Tower)

8. Secure the internal 3½-inch device bay to the chassis using the screw removed in step 5.
9. Connect the power and data cables.

Refer to "Connecting Diskette and IDE Devices" later in this chapter.

Connecting Diskette and IDE Devices (Venturis FX and Celebris FX Low Profile)

If you are installing a second IDE drive, first check the documentation that came with your drive for master/slave jumper ID settings.

To connect diskette and IDE devices, perform the following:

1. Connect the supplied ribbon cable to the appropriate device as shown in figures 6-9 and 6-10.



NOTE: If only one IDE device is installed, make sure you use the ribbon cable connector furthest from the main logic board connector.

Make sure the cable is connected with the correct orientation. Most cables and sockets are keyed so you cannot connect them backwards. If your cable or device is not keyed, you must connect pin 1 of the cable to pin 1 of the device's socket.

Pin 1 of the cable is on the edge with the colored stripe. Pin 1 of the device's socket should be marked with a number or symbol at one end of the socket or with a number or symbol printed on the circuit board near one end of the socket. If necessary, refer to the device's documentation for pin 1 orientation.

If the IDE device is a CD-ROM drive, connect it to the secondary IDE port on the backplane and then configure it to be a master device.

2. Connect the appropriate power cable to device.
3. Replace the outside cover.
4. Connect all external devices and restore power.
5. Run the BIOS Setup utility to configure computer.

Refer to Chapter 2, "Using the BIOS Setup Utility."

Adding Mass Storage Devices

Figure Legend	Diskette Drive Component
A	Power supply
B	Power connection
C	Diskette drive connections
D	Backplane diskette drive connection
E	Diskette drive

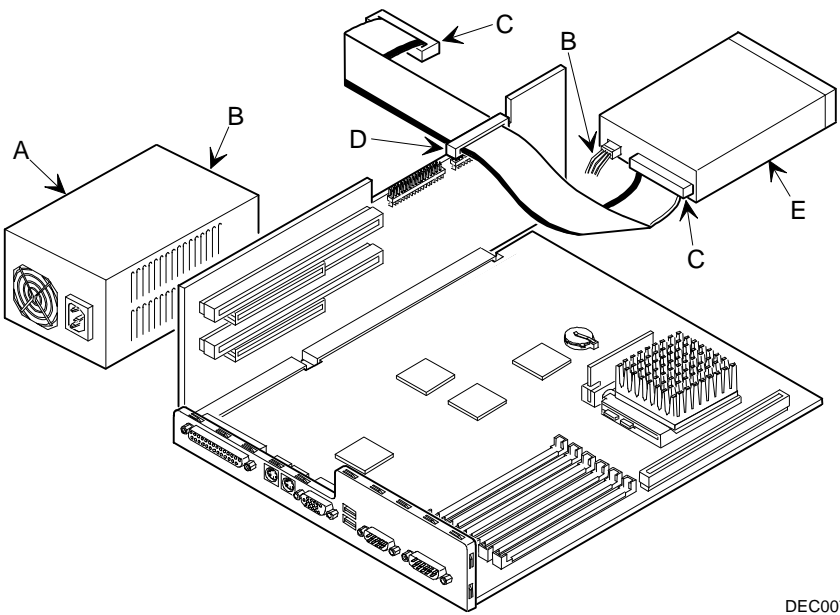

DEC0076

Figure 6-9. Diskette Drive Data Cable Connections (Venturis FX and Celebris FX Low Profile)

Adding Mass Storage Devices

Figure Legend	IDE Drive Component
A	Power supply
B	Primary IDE hard disk drive
C	Power connections
D	Primary IDE hard disk drive connections
E	Backplane IDE drive connection (primary)
F	Secondary IDE hard disk drive connections
G ⁽¹⁾	CD-ROM drive (not available on all models)
H	Backplane IDE drive connection (secondary)

⁽¹⁾ The CD-ROM drive is connected to the secondary IDE port and configured as a master drive.

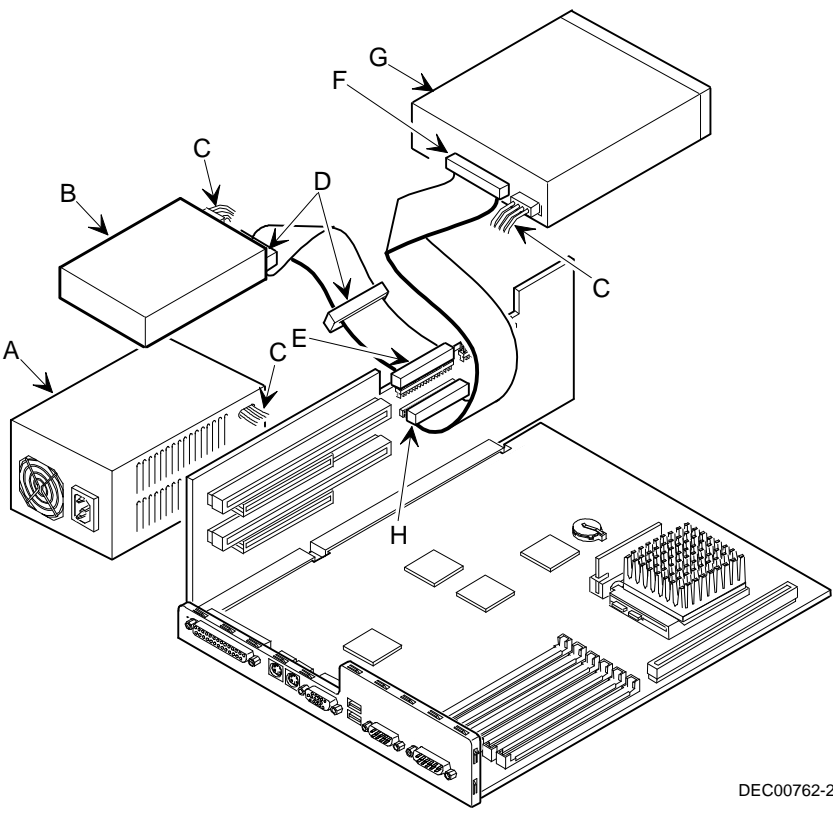

DEC00762-2

Figure 6-10. IDE Drive Data Cable Connections (Venturis FX and Celebris FX Low Profile)

Connecting Diskette and IDE Devices (Venturis FX Short Tower)

If you are installing a second IDE drive, first check the documentation that came with your drive for master/slave jumper ID settings.

To connect a diskette or IDE device, perform the following:

1. Connect the supplied ribbon cable to the device as shown in Figure 6-11 and 6-12.



NOTE: If only one IDE device is installed, make sure you use the ribbon cable connector furthest from the main logic board connector.

Make sure the cable is connected with the correct orientation. Most cables and sockets are keyed so you cannot connect them backwards. If your cable or device is not keyed, you must connect pin 1 of the cable to pin 1 of the device's socket.

Pin 1 of the cable is on edge with the colored stripe. Pin 1 of device's socket should be marked with a number or symbol at one end of the socket or with a number or symbol printed on the circuit board near one end of the socket. If necessary, refer to the device's documentation for pin 1 orientation.

If the IDE device is a CD-ROM drive, connect it to the secondary IDE port on the backplane and then configure it to be a master device.

2. Connect a power cable to device.
3. Replace the outside cover.
4. Connect all external devices and restore power.
5. Run the BIOS Setup utility to configure computer.

Refer to Chapter 2, "Using the BIOS Setup Utility."

Figure Legend	Diskette Drive Component
A	Power connection
B	Diskette drive
C	Diskette drive connections
D	Backplane diskette drive connection
E	Power supply

Adding Mass Storage Devices

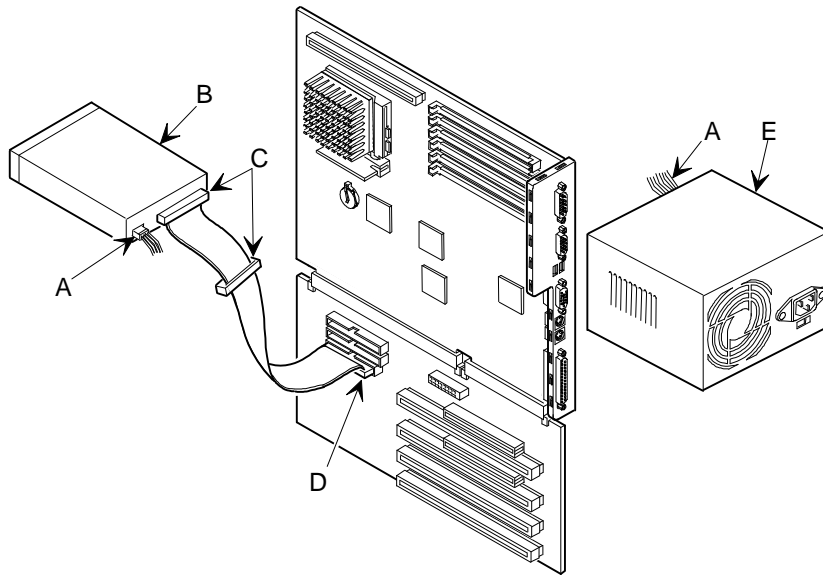

DEC00763-2

Figure 6-11. Diskette Device Data Cable Connections (Venturis FX Short Tower)

Figure Legend	IDE Drive Component
A	Backplane IDE drive connection (primary)
B	Power connections
C	Power supply
D	Primary IDE hard disk drive
E	Primary IDE hard disk drive connections
F	Backplane IDE drive connection (secondary)
G	Secondary IDE hard disk drive connections
H ⁽¹⁾	CD-ROM drive (not available on all models)

⁽¹⁾ The CD-ROM drive is connected to the secondary IDE port and configured as a master drive.

Adding Mass Storage Devices

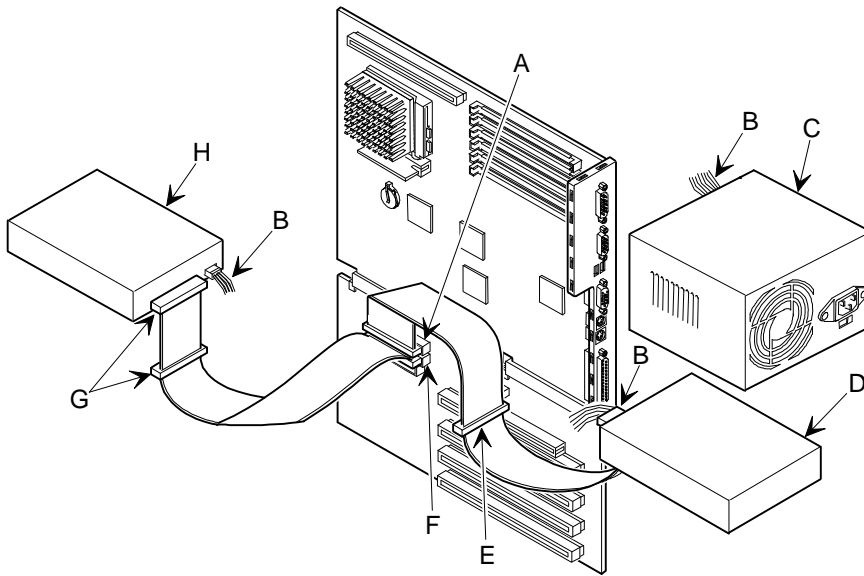

DEC00961-2

Figure 6-12. IDE Device Data Cable Connections (Venturis FX Short Tower)

Technical Specifications

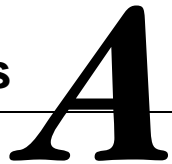

Introduction

This appendix provides information about the technical characteristics of the Venturis FX and Celebris FX computers.

- Computer specifications
- ISA and PCI expansion slots
- Power supply and input power
- Nominal current requirements
- Power cord requirements
- Main logic board jumper settings
- Processor jumper settings
- If you forget your password

Computer Specifications

The following sections list the Venturis FX and Celebris FX computer performance, dimensions, and environmental specifications by model.

Features

Feature	Specification
Secondary cache	256 KB pipelined-burst module standard on most models 512 KB pipelined-burst module optional
Internal cache	16 KB
Video memory	1 MB standard, upgradable to 2 MB
Network	Single-chip controller for PCI bus (not available on all models) Supports a 10Base-T (Twisted-Pair) connection
Audio	ESS single-chip controller with 16-bit stereo audio and 20-voice FM music synthesizer (Venturis FXsm only)

Performance Specifications

Attributes	Specification
ISA clock	7.5/8.33 MHz
PCI clock	25 MHz/33 MHz
Data I/O	
ISA	8-bit and 16-bit
PCI	32-bit
Main logic board	72-pin, EDO memory
DRAM	8 MB or 16 MB standard (expandable up to 192 MB, using 32 MB SIMMs)
System BIOS	128 KB FLASH ROM
Video BIOS	32 KB included in the second 128 KB Flash ROM

Computer Dimensions (Venturis FX and Celebris FX Low Profile)

Dimension	Specification
Width	450.8 mm (17.75 in.)
Length	419.1 mm (16.5 in.)
Height	105.7 mm (4.2 in.)
Weight	14.1 kg (31.2 lb)

Computer Dimensions (Venturis FX Short Tower)

Dimension	Specification
Width	215.9 mm (8.5 in.)
Depth	444.5 mm (17.5 in.)
Height	406.4 mm (16.0 in.)
Weight	15.2 kg (33.6 lb)

Environmental Specifications

Attributes	Specification
Operating temperature	10 °C to 40 °C (50 °F to 104 °F)
Storage temperature	−40 °C to 66 °C (−40 °F to 150.8 °F)
Operating humidity (noncondensing)	20% to 80% relative humidity, maximum wet bulb 40 °C (104 °F)
Storage humidity (noncondensing)	10% to 95% relative humidity, maximum wet bulb 65 °C (149 °F)
Altitude	
Operating	2,000 m (6,562 ft) maximum
Nonoperating	3,600 m (12,000 ft) maximum
Shipping vibration	IAW Federal Standard 101, method 5019
Nonoperating shock	30 G, 25 ms halfsine

ISA Expansion Slots

The maximum available +5 V dc current allowable to any ISA expansion slot depends upon the following parameters:

- Power supply capacity
- The +5 V dc requirements of the main logic board
- The +5 V dc requirements of the peripherals
- The power demands of all other slots in use

PCI Local Bus Expansion Slots

Your computer's backplane contains two PCI local bus expansion slots. These slots support:

- Universal 3.3 V dc and 5 V dc PCI expansion boards
- Standard power PCI expansion slots (up to 25 watts)
- Bus mastering

Venturis FX and Celebris FX Low Profile System Input Power Requirements

Rated Voltage Range	Maximum Range	Rated Input Current @ 100 W	Operating Frequency Range
100 V ac - 120 V ac	88 V ac - 135 V ac	2.0 A	47 Hz - 63 Hz
220 V ac - 240 V ac	176 V ac - 265 V ac	1.1 A	47 Hz - 63 Hz

Venturis FX Short Tower System Input Power Requirements

Rated Voltage Range	Maximum Range	Rated Input Current @ 200 W	Operating Frequency Range
100 V ac - 120 V ac	88 V ac - 135 V ac	2.5 A	47 Hz - 63 Hz
220 V ac - 240 V ac	176 V ac - 265 V ac	1.3 A	47 Hz - 63 Hz

Power Supply Requirements

Venturis FX and Celebris FX computer power supplies provide six dc voltages: +12 V dc, -12 V dc, +5 V dc, -5 V dc, 5 VSB, and +3.3 V dc. These voltages are used by the various components within the computer.

Current Requirements

Your computer's power supply provides the following maximum current requirements:

Venturis FX and Celebris FX Low Profile (100 W)

- Total power 100 W maximum
 - +3.3 V 0 A min, 7.0 A max.
 - +5 V 2.0 A min, 11 A max.
- +12 V 0 A min, 3.5 A max.
- -5 V 0 A min, 0.3 A max.
- -12 V 0 A min, 0.3 A max.
- 5 VSB 0 A min, 0.02 A max.

Venturis FX Short Tower (200 W)

- Total power 200 W maximum
 - +3.3 V 0.5 A min, 13.0 A max.
 - +5 V 2.0 A min, 22.0 A max.
- +12 V 0 A min, 6.0 A max.
- -5 V 0 A min, 0.5 A max.
- -12 V 0 A min, 0.5 A max.
- 5 VSB 0 A min, 0.05 A max.

Power Cord Requirements



WARNING: Do not attempt to modify or use an external 100 V ac (Japan only) or 115 V ac power cord for 220-240 V ac input power. Modifying either power cord can cause personal injury and severe equipment damage.

The power cord used with this computer must meet the following criteria:

- UL and CSA Certified cordage rated for use at 250 V ac with a current rating that is at least 125% of the current rating of the product. In Europe, the cordage must have the <HAR> mark.
- The ac plug is terminated in a grounding-type male plug designed for use in the region. It must also have marks showing certification by an agency acceptable in the region.
- The connector at the computer end is an IEC type CEE-22 female connector.
- The maximum length is 4.5 meters (14.5 feet).

Main Logic Board Jumper Settings

Feature	Function	Setting	Description
CMOS clear	Discharge Normal ⁽¹⁾	J3, 4-5, jumpered J3, 5-6, jumpered ⁽¹⁾	Clears CMOS of all BIOS information when jumper is set for Discharge. Use the Discharge setting when you need to reconfigure your computer's resources. After discharging CMOS, you must reset the jumper to Normal before rebooting your computer.
Recovery mode	Recovery mode Normal ⁽¹⁾	J1, 3-4, jumpered J1, 3-4, unjumpered ⁽¹⁾	Enables you to boot from a Recovery Disk should an error occur while you are flashing the BIOS.
Boot block update	Enabled Disabled ⁽¹⁾	J3, 1-2, jumpered J3, 2-3, jumpered ⁽¹⁾	Set this jumper to disabled to prevent unauthorized personnel from changing the BIOS boot block.
Password clear	Password clear (MFG test) Normal mode ⁽¹⁾	J1, 1-2, jumpered J1, 1-2, unjumpered ⁽¹⁾	If you forget your password, set this jumper to password clear and then restart the computer.
ASYNC/ Pipe burst SRAM	ASYNC Burst ⁽¹⁾	J3, 7-8, jumpered J3, 8-9, jumpered ⁽¹⁾	This setting determines how the SRAM, cache memory is addressed and used.
Factory setting		J1, 13-14	Reserved.

(1) Factory default setting

Processor Jumper Settings

The following table provides the jumper settings for various available Pentium processors. The jumpers are set correctly for the processor that came with the computer you purchased. You only need to change the processor jumper settings, that is J1, should you upgrade to another processor.

Pentium Processor	J1 Pin Settings				
	In MHz	Pins 5 and 6	Pins 7 and 8	Pins 9 and 10	Pins 11 and 12
75	On	On	Off	Off	Off
100	Off	Off	Off	Off	Off
120	On	Off	Off	Off	On
133	Off	Off	Off	Off	On
150	On	Off	Off	On	On
166	Off	Off	Off	On	On
200	Off	Off	Off	On	Off

Some processors might be unavailable or others might be introduced.

If You Forget Your Password

Use the following procedure to erase a password from your computer.

1. Turn off your computer and remove the outside cover.
2. Change jumper J1 (pins 1 and 2) to password clear (jumper installed).
3. Reconnect your computer and turn it on.

Booting your computer with this switch in the on position erases the existing password(s).

4. Turn off your computer and remove the outside cover.
5. Change jumper J1 (pins 1 and 2) to normal mode (jumper not installed).
6. Reconnect your computer and turn it on.
7. Using the BIOS Setup utility, assign a new password.

Refer to Chapter 2, "Using the BIOS Setup Utility," for more information.

Device Mapping *B*

Introduction

This appendix provides a series of tables listing mapping and address information related to computer memory and various main logic board devices (keyboard controller, interrupt controller, DMA controller, etc.).

Your computer's memory and address locations are allocated at the factory to operate within a standard PC environment. However, due to the number of optional devices and/or expansion boards that are available, sometimes memory and address locations need to be changed. For example, some network expansion boards require a specific memory location. If that location is already allocated, a memory conflict results and the expansion board will not operate as expected. Note that some memory, I/O and interrupt locations can be changed using the BIOS Setup utility.

Refer to Chapter 2, "Using the BIOS Setup Utility," for additional information.



CAUTION: Before changing any memory or address location, refer to the documentation supplied with the optional device, expansion board, or software application and make sure adequate information is available. If not, contact the option or software manufacturer for further information.

CPU Memory Address Map (Full Range)

Range	Function	Size
0 to 9FFFFh	Base memory	640 KB
A0000h to BFFFFh	Video RAM	128 KB
C0000h to C7FFFh	VGA BIOS	32 KB
C8000h to DFFFFh	BIOS extension ROM (AT bus used)	96 KB
E0000h to FFFFFh	PnP BIOS/APM BIOS	128 KB
100000h to BFFFFFFh	Extended memory	191 MB

I/O Address Map

Range (hexadecimal)	Function
000 - 00F	DMA controller one
020 - 021	Interrupt controller one
022	Index register (Sis5513)
023	Data register (Sis5513)
040 - 043	Interval timer
060 - 06F	Keyboard controller
070 - 07F	Real-Time Clock (RTC), NMI
080 - 08F	DMA page register
0A0 - 0A1	Interrupt controller two
0C0 - 0CF	DMA controller two
0F0	Clear math co-processor busy
0F1	Reset math co-processor
0F8 - 0FF	Math co-processor
170 - 177	Secondary IDE controller
1F0 - 1F7	Primary IDE controller
201	Joystick
220 - 22F	Audio
278 - 27A	LPT2
2E8 - 2EF	COM4

continued

Device Mapping

Range (hexadecimal)	Function
2F8 - 2FF	COM2
300 - 301	MIDI MPU (Venturis FXsm only)
310 - 311	
320 - 321	
330 - 331 ⁽¹⁾	
378 - 37A	LPT1
388 - 38B	Audio, FM music synthesizer
3BC - 3BE	LPT3
3E8 - 3EF	COM3
3F0 - 3F7	Diskette (floppy disk) controller
3F6 - 3F7	Primary/secondary IDE controller (alt status, device address)
3F8 - 3FF	COM1
4D0	Edge/level control register - INTCNTRL1
4D1	Edge/level control register - INTCNTRL2
CF8 - CFF	PCI configure space control register
CC00	Programming chip select

⁽¹⁾ These are the possible ranges. If the device is Plug and Play and you are using it with a Plug and Play operating system, such Windows 95, Plug and Play will select the correct address. Otherwise, use the ICU to determine an available I/O address.

Computer Interrupt Levels

Interrupt Number	Interrupt Source
IRQ0	Timer tick
IRQ1	Keyboard controller
IRQ2	Cascade interrupt
IRQ3	COM2, COM4, if enabled
IRQ4	COM1, COM3, if enabled
IRQ5	Audio, if enabled
IRQ6	Diskette (floppy disk) drive, if enabled
IRQ7	LPT1, LPT3, if enabled
IRQ8	Real Time Clock (RTC)
IRQ9	Video
IRQ10	Reserved
IRQ11	Network
IRQ12	Mouse interrupt, if enabled
IRQ13	Math co-processor
IRQ14	IDE primary, if enabled
IRQ15	IDE secondary, if enabled

DMA Channel Assignment

Channel	Controller	Function
0	1	Refresh
1	1	Audio or ECP
2	1	Diskette (floppy disk) controller, if enabled
3	1	Not used
4	2	Cascade DMA
5	2	ECP or not used
6	2	Not used
7	2	Not used

Video Output Information

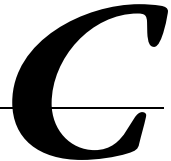

Introduction

Venturis FX and Celebris FX computers can be used with a variety of industry-standard VGA analog monitors. These computers also support several PCI local bus video adapters as well as many industry-standard ISA video adapters.



CAUTION: Your monitor's capabilities must match the capabilities of the onboard video controller or an optional video adapter if you select a video resolution higher than 640 x 480. Failure to match video capabilities can damage your monitor.

Also, do not connect a low-resolution monitor to a computer that has been configured with high-resolution video drivers. High-resolution drivers can damage a low-resolution monitor.



NOTE: Refer to your monitor's documentation and the following table to determine the maximum video resolution of your monitor and onboard video controller. If you are using an optional video adapter, refer to the documentation supplied with that adapter to determine the maximum video resolution.

Video Output Information

When using the following video output tables to change your computer's resolution setting, consider that the third number of the resolution mode column refers to colors as follows:

- 8 = 256 colors
- 15 = 32 K colors
- 16 = 64 K colors
- 24 = 16.7 million colors (slow speed)
- 32 = 16.7 million colors (high speed)

Video Resolution Modes

Resolution Mode	Horizontal Freq (kHz)	Vertical Freq (Hz)	Dot Clock (MHz)	Video Memory Size
640 x 480 x 8	31.5	60 (NI)	25.175	1 MB/2 MB
640 x 480 x 8	37.9	72 (NI)	31.500	1 MB/2 MB
640 x 480 x 8	37.5	75 (NI)	31.500	1 MB/2 MB
640 x 480 x 8	45.2	85 (NI)	36.000	1 MB/2 MB
640 x 480 x 15	31.5	60 (NI)	25.175	1 MB/2 MB
640 x 480 x 15	37.9	72 (NI)	31.500	1 MB/2 MB
640 x 480 x 15	37.5	75 (NI)	31.500	1 MB/2 MB
640 x 480 x 15	45	85 (NI)	36.000	1 MB/2 MB
640 x 480 x 16	31.5	60 (NI)	25.175	1 MB/2 MB
640 x 480 x 16	37.9	72 (NI)	31.500	1 MB/2 MB
640 x 480 x 16	37.5	75 (NI)	31.500	1 MB/2 MB
640 x 480 x 16	45	85 (NI)	36.000	1 MB/2 MB
640 x 480 x 32	31.5	60 (NI)	25.175	2 MB
640 x 480 x 32	37.9	72 (NI)	31.500	2 MB
640 x 480 x 32	37.5	75 (NI)	31.500	2 MB
640 x 480 x 32	45.2	85 (NI)	36.000	2 MB

NI = Noninterlaced

Video Output Information

Resolution Mode	Horizontal Freq (kHz)	Vertical Freq (Hz)	Dot Clock (MHz)	Video Memory Size
800 x 600	37.8	60 (NI)	40.000	2 MB
800 x 600	48.2	72 (NI)	50.000	2 MB
800 x 600	46.8	75 (NI)	49.500	2 MB
800 x 600	53.5	85 (NI)	56.600	2 MB
800 x 600 x 8	37.9	60 (NI)	40.000	1 MB/2 MB
800 x 600 x 8	48.1	72 (NI)	50.000	1 MB/2 MB
800 x 600 x 8	46.9	75 (NI)	49.500	1 MB/2 MB
800 x 600 x 8	53.5	85 (NI)	56.600	1 MB/2 MB
800 x 600 x 15	37.9	60 (NI)	40.000	1 MB/2 MB
800 x 600 x 15	48.1	72 (NI)	50.000	1 MB/2 MB
800 x 600 x 15	46.8	75 (NI)	49.500	1 MB/2 MB
800 x 600 x 15	53.5	85 (NI)	56.500	1 MB/2 MB
800 x 600 x 16	37.9	60 (NI)	40.000	1 MB/2 MB
800 x 600 x 16	48.1	72 (NI)	50.000	1 MB/2 MB
800 x 600 x 16	46.8	75 (NI)	69.500	1 MB/2 MB
800 x 600 x 16	53.5	85 (NI)	56.500	1 MB/2 MB

NI = Noninterlaced

Video Output Information

Resolution Mode	Horizontal Freq (kHz)	Vertical Freq (Hz)	Dot Clock (MHz)	Video Memory Size
1024 x 768 x 8	35.5	43 (I)	44.900	1 MB/2 MB
1024 x 768 x 8	48.4	60 (NI)	65.000	1 MB/2 MB
1024 x 768 x 8	56.5	70 (NI)	75.000	1 MB/2 MB
1024 x 768 x 8	60.9	75 (NI)	78.750	1 MB/2 MB
1024 x 768 x 8	68.8	85 (NI)	94.500	1 MB/2 MB
1024 x 768 x 15	35.5	43 (I)	44.900	2 MB
1024 x 768 x 15	48.9	60 (NI)	65.000	2 MB
1024 x 768 x 15	56.5	70 (NI)	75.000	2 MB
1024 x 768 x 15	60.2	75 (NI)	78.750	2 MB
1024 x 768 x 15	68.7	85 (NI)	94.500	2 MB
1024 x 768 x 16	35.5	43 (I)	44.900	2 MB
1024 x 768 x 16	48.9	60 (NI)	65.000	2 MB
1024 x 768 x 16	56.5	70 (NI)	75.000	2 MB
1024 x 768 x 16	60.2	75 (NI)	78.750	2 MB
1024 x 768 x 16	68.9	85 (NI)	94.500	2 MB
1152 x 864 x 8	55.0	60 (NI)	80.000	1 MB/2 MB
1280 x1024 x 8	46.4	43 (I)	78.750	2 MB
1280 x1024 x 8	64	60 (NI)	108.000	2 MB
1280 x1024 x 8	77.6	72 (NI)	130.000	2 MB
1600 x 1200 x 8	62.3	48 (I)	135.000	2 MB

NI = Noninterlaced

I = Interlaced

address

A specific location or range of locations in your computer's memory or in a port (such as a parallel or serial port). Memory addresses specify the location of information, while I/O addresses specify the location of a port used by a particular component of your computer.

application

A program or set of programs that operate in conjunction with an operating system, also called "application software." Categories of application software include word processors, databases, spreadsheets, and telecommunications software. Specific examples of application software include WordPerfect, Lotus 1-2-3, and Procomm Plus.

base memory

Memory accessible to MS-DOS, up to a maximum of 640 KB; also called "conventional memory." See also expanded memory (EMS) and extended memory (XMS).

Basic Input/Output System (BIOS)

Abbreviated as BIOS and pronounced "by-oss." The BIOS enables your computer to control major input/output devices such as the keyboard and disk drives.

batch file

A defined series of commands saved in a file, which can then be executed as a unit in order to save time and/or keystrokes. MS-DOS batch files have the extension .BAT. Batch files created for other operating systems, such as Windows 95 or Windows NT Workstation, might have other extensions.

Glossary

baud

A unit of speed in data transmission, as one bit per second for binary signals. See also bits-per-second (bps).

bit

The smallest unit of electronically stored information, represented by the binary digits 0 or 1. See also byte.

bits per second

Abbreviated as bps. The number of binary digits transmitted by an electronic device (such as a modem) in one second. Also see baud and bit.

board

A device containing electronic circuitry and microprocessors. Usually used in connection with a modifying word, as follows:

- main logic board - The primary electronic component of your computer
- expansion board - A board which enhances your computer's abilities in some way
- video board - A board which enables your computer to display information on a monitor

booting

The process of self-testing and computer configuration that completes each time your computer is turned on (a "hard boot") or restarted (a "soft boot" or "reboot") by pressing the reset button or the [Ctrl]-[Alt]-[Del] key combination. This might include a memory test, loading of device drivers via CONFIG.SYS, and execution of the AUTOEXEC.BAT file.

byte

The amount of storage space used to represent one character (such as a letter or number). One byte contains eight bits. The following table describes other commonly-used units of electronic storage space. These units are typically used to describe amounts of available memory.

Kilobit (Kb)	1,024 bits
Kilobyte (KB)	1,024 bytes
Megabit (Mb)	1,048,576 bits
Megabyte (MB)	1,048,576 bytes
Gigabyte (GB)	1,073,741,824 bytes

cache memory

A block of reserved memory that improves computer performance by minimizing the number of processor memory accesses. The computer achieves this by storing recently used data or instructions in reserved memory, where it can be retrieved more quickly.

CD-ROM

Compact Disk-Read Only Memory. The CD-ROM drive and CD-ROM disk comprise an integral part of a multimedia computer system. The disk stores a very large amount of audio, video, graphic and/or encyclopedic information that is read by the drive for use in a computer application. Because the disk is read only, you cannot write to the disk from your computer's hard drive, floppy drive, or from your computer's memory.

ClientWORKS

ClientWORKS is the family of client management and networking tools that Digital supports on its entire line of desktop personal computers. The Client Management feature provides computer users with an easy method to keep track of their components. See Desktop Management Interface.

CMOS

A type of memory that uses very little power. CMOS memory is often used to store information such as the time and date for your computer's internal clock.

COAST

Cache on a stick (module).

cursor

A line, block, or other indicator on your monitor screen. The cursor identifies the point at which typed characters or other information will appear on the screen. Note that while a mouse or other pointing device can often be used to move the cursor, the mouse-pointer and a normal cursor might appear in different places on your screen.

DDC

Display Data Channel - a feature that queries the monitor to identify itself to the computer which then chooses the optimal refresh rate for the monitor.

Desktop Management Interface (DMI)

DMI is a component of ClientWORKS and provides an enhanced and powerful set of utilities and software to help network administrators keep track of the installed hardware and software, either locally or on a network. See ClientWORKS.

device driver

A file that gives your computer specific information on operating a particular physical device (such as a CD-ROM drive or a mouse) or application software (such as a memory manager). Device drivers are usually loaded into memory each time your computer boots if they are listed in your CONFIG.SYS file.

Direct Memory Access (DMA)

DMA displays or delivers information from your computer's memory without making use of the processor. Devices with DMA capability (for example, many sound cards) must be properly configured in order for your computer to recognize and make use of this ability.

DPMS

1. Display Power Management Signaling. Technology that enables video controller circuitry to control the operating condition of a monitor, thereby decreasing the monitor's energy consumption.
2. DOS Protected Mode Services. A way for a software application to access extended memory, often by use of a specialized device driver. Examples of software that uses DPMS include certain versions of Stacker and PKZip.

EDO

See Extended Data Out.

Enhanced Parallel Port (EPP)

An option available in your computer's BIOS which affects the way a printer attached to your parallel port communicates with your computer. If your printer supports this standard, enabling the EPP option will allow faster printing. This specification also provides a parallel port with the expansion bus ability to support up to 64 external devices, such as: disk drives, tape drives, CD-ROM drives, and other mass-storage devices.

expanded memory (EMS)

Memory beyond 640 KB that can only be accessed by use of expanded memory manager software. Expanded memory can be provided by installing an expanded memory expansion board, or by using software that enables extended memory to simulate expanded memory. Some application software requires expanded memory in order to operate correctly.

Extended Capabilities Port (ECP)

An option available in your computer's BIOS which affects the way a printer attached to your parallel port communicates with your computer. If your printer supports this standard, enabling the ECP option will allow faster printing.

Extended Data Out (EDO)

A DRAM feature that allows for fast, main memory access timing. EDO memory is faster than Fast Page memory (which was the former industry standard) and is available in 8-MB and 16-MB SIMMs.

extended memory (XMS)

Memory beyond 1 MB that can only be accessed by use of extended memory manager software (such as HIMEM.SYS, included with MS-DOS and Windows). Some application software, including Windows and Windows-based software, requires extended memory in order to operate correctly. Extended memory can be added to your computer, within specified limits, by installing SIMMs.

firmware

Information that is permanently stored in your computer's ROM and cannot be changed. This might consist of application software and/or configuration information about certain aspects of the computer. Your computer's BIOS (see Basic Input/Output System) is an example of firmware.

graphical user interface

Abbreviated as GUI. The visual "desktop" image generated by software such as Windows, that allows you to operate your computer by using a mouse or other pointing device to manipulate icons that might represent application software, files containing data, and/or operating system commands. An alternative to a command line.

hardware

Computers, printers, modems and other physical devices for managing electronically stored information.

icon

A symbol or picture on your monitor screen that represents a file, a software application, an operating system command, or some other form of stored information. Groups of icons might sometimes be referred to as button bars or toolbars.

interrupt

An event, condition, or instruction which causes your computer to temporarily stop performing a task, but does so in a way that permits the task to be resumed and completed later. For example, not using your keyboard or mouse for several minutes might cause a screen saver program to interrupt another software application. Interrupts also occur within your computer's memory that cannot be easily detected by users.

IRQ

A hardware setting which instructs your computer how to allocate memory resources between various components of the system. For example, serial ports COM1 and COM3 are often assigned to the same IRQ setting. If IRQ settings are not properly allocated to the various components of your computer (such as expansion boards), your computer might not be able to operate all of the affected components.

An IRQ setting on a given component establishes an interrupt condition for that component.

JPEG

Joint Photographic Experts Group, pronounced "jay-peg" - An image-compression algorithm that can reduce a bitmapped image by a factor of 10 or more. Because of the nature of the compression, there is little or no discernible image degradation. Also see MPEG and LPB.

jumper

Jumper pins allow you to set specific computer parameters. They are set by changing the pin location of jumper blocks. A jumper block is a small, plastic-encased conductor (shorting plug) that slips over the pins. To change a jumper setting (make sure that your computer is turned OFF), remove the jumper from its current location with your fingers. Position the jumper over the two pins designated for the desired setting. Press the jumper evenly onto the pins; being careful not to bend the pins.

Kbyte

A Kilobyte (Kbyte, KB) is a unit, usually of computer storage space, equal to 1,024 bytes. Also see byte and bit.

legacy

A legacy expansion board is any ISA board that does not comply with the new Plug and Play ISA Board Specification. Legacy ISA boards must be configured using the ISA Configuration Utility (ICU).

LPB

Live Play Back. This is a feature of some multimedia video playback, video adapters that allows fast-frame digital video. Also see JPEG and MPEG.

mapping

The process of identifying specific addresses and locations within your computer's memory, and describing what kinds of information might be found at those locations. Sometimes referred to as device mapping or memory mapping.

media

Physical objects or devices used for storing information. These might include floppy disks, hard disk drives, CD-ROM disks, and PCMCIA cards.

memory

The electronic space in which information can be stored and/or processed. Types of memory include Random Access Memory (RAM), Read-Only Memory (ROM), expanded memory (EMS) and extended memory (XMS).

memory-resident

A condition in which software remains loaded in your computer's memory but does not operate until and unless it is activated by the user or by another software application. For example, a virus-detection program might be memory-resident.

MPEG

Motion Picture Experts Group, pronounced "em-peg." This group of motion picture professionals established the standards for the display of animated or motion pictures on your computer. This multimedia video playback standard allows digital video compression using JPEG image compression and other encoding for video sequences. Also see JPEG and LPB.

microprocessor

A computer chip that processes electronic information and instructions, such as Intel's Pentium or Pentium-Pro computer chips. Note, however, that not all microprocessors are central processing units.

modem

A device for transmitting electronic information from one computer to another at high speeds over telephone lines.

multimedia

A form of electronic information that combines pictures, sounds, and text in an integrated manner. CD-ROM hardware and software is usually required to make use of information stored in the form of multimedia.

onboard video

Video controller circuitry that is incorporated into a computer's main logic board, so that you do not need a separate video adapter to display information on a monitor.

operating system

The software that tells your computer how to manage and process electronically stored information, enables it to run application software, and controls the flow of information between various parts of your computer system. MS-DOS, OS/2, and UNIX are operating systems.

PCI

Peripheral Component Interconnect - provides fast, 32-bit, I/O data transfer.

Pel - Picture Element, also known as Pixel

The smallest graphic unit that can be displayed on the screen of your monitor. This unit is usually a single-colored dot; the size of the dot is determined by the dot pitch of your monitor (typically .25 mm to .42 mm).

port

The physical connection between your computer and a peripheral device, such as a printer, mouse, or SCSI device.

Parallel ports, also called LPT ports, are typically used to connect your computer to a printer. Serial ports, also called COM ports, can be used to connect your computer to a variety of devices, including a mouse, a modem, and some printers. Other types of ports can include keyboard ports, mouse ports, and SCSI ports. See EPP.

Power-On Self Test (POST)

A series of diagnostic tests performed by your computer every time it is turned on (but not necessarily every time it is booted).

quiet boot

Inhibits the display of POST messages. Quiet boot, when enabled, displays the Digital logo, instead of POST messages.

Random Access Memory (RAM)

Abbreviated as RAM; also called read/write memory. The memory your computer uses to manage information and software while that information and software is in use. Information stored only in RAM is lost when your computer is turned off.

Read-Only Memory (ROM)

Abbreviated as ROM. Information or software stored in ROM is permanent, cannot be altered, and remains intact when your computer is turned off. Note that you cannot move or copy information into ROM from other areas of your computer's memory. In some cases, however, you can copy information from ROM into other areas of your computer's memory.

ROM BIOS

See Basic Input/Output System and Read-Only Memory. ROM BIOS software enables your computer to control major input/output devices such as the keyboard and disk drives.

SCSI device

Hardware that communicates with your computer via a specific data-transmission technology (Small Computer System Interface). Devices that use the SCSI interface include CD-ROM drives and some hard disk drives.

SIMM

A Single In-line Memory Module. SIMMs are small memory cards (sometimes called "sticks") that can be used to increase the amount of random access memory (RAM) in your computer.

software

A program or set of programs that operate in conjunction with an operating system, also called "application software." Categories of application software include word processors, databases, spreadsheets, and telecommunications software. Specific examples of application software include Word for Windows, MS Excel, and Procomm Plus.

system utilities

Software designed to increase your computer's efficiency, determine whether it is operating properly, and/or correct problems that might arise as you use your computer. Some system utility software might be provided with your computer (such as a Setup program). Other utility software is available from various commercial and non-commercial sources. Examples of utility software include Stacker, PKZip, and Norton Utilities.

upper memory

The area of memory between base memory (640 KB) and 1 MB. When properly configured, Windows 95 or Windows NT Workstation can load device drivers, and memory-resident software into upper memory. While the upper memory area can be configured as expanded memory, expanded memory is not limited to the upper memory area.

video adapter

Also called a video controller or video board. A board that enables your computer to display information on a monitor screen.

video controller

The electronic circuitry which enables your computer to display information on a monitor screen. This might be provided on a video adapter or on the main logic board. In the latter case, it is referred to as onboard video.

WaveTable

An audio (sound) synthesis device that provides life-like sound because it is based on actual recordings of real instruments. The WaveTable is usually a small adapter (daughter card) that attaches to the sound card or built-in sound circuitry on the main logic board.

Windows

Software that provides a graphical user interface for use in operating your computer.

ZIF socket

Zero Insertion Force socket - These sockets are provided for easy upgrade of processors. They require no tools for removing and replacing the processor chip.

Index

- 3½-inch mass storage devices
 - installing
 - Venturis FX and Celebris FX low profile, 6-2
 - Venturis FX short tower, 6-7
- 3½-inch mass storage devices (internal drive bay)
 - installing
 - Venturis FX short tower, 6-12
- 5¼-inch mass storage devices
 - installing
 - Venturis FX and Celebris FX low profile, 6-5
 - Venturis FX short tower, 6-10

A

- assignment
 - DMA channel, B-6

B

- battery
 - replacing, 3-20
- BIOS setup utility, 2-1
 - accessing, 2-2
 - changing boot sequence, 2-15
 - changing time and date, 2-4
 - configuring diskette drives, 2-12
 - configuring hard disk drives, 2-13
 - eliminating passwords, 2-7

- enabling password on boot, 2-6
- executing, 2-2
- helpful hints, 2-2
- maneuvering through, 2-4
- other security options, 2-9
- quick suspend option, 2-11
- resetting keyboard features, 2-17
- setting passwords, 2-4
- setting power management options, 2-10
- setting volume control, 2-19
- speed up boot, 2-16
- virus protection, 2-8

C

- Celebris FX low profile backplane
 - components and connectors, 3-12
- Celebris FX network adapter card
 - connectors, 3-16
- chassis lockdown
 - attaching hasp Venturis FX and Celebris FX low profile, 1-13
 - attaching hasp Venturis FX short tower, 1-14
- computer, 1-12
- components
 - main logic board, 3-4

Index

components and connectors

- Celebris FX low profile backplane, 3-12
- Venturis FX low profile backplane, 3-10
- Venturis FX short tower backplane, 3-14

computer

- chassis lockdown, 1-12
- disconnecting external devices, 1-8
- energy star information, xv
- installing a processor, 3-23
- installing a VRM, 3-25
- installing expansion boards, 5-6
- installing SIMMs, 4-1
- prepare for expansion, 3-2
- replacing computer battery, 3-20
- video output information, C-1

computer components, 3-2

- configuring expansion slots, 5-1
- connecting a local printer, 1-18
- connecting a microphone, 1-17
- connecting a MIDI/joystick device, 1-22
- connecting headphones, 1-16
- connecting speakers, 1-15
- connecting USB devices, 1-20

connectors

- Celebris FX network adapter card, 3-16
- main logic board, 3-8

current limitation

- expansion slots, A-4
- PCI-bus (local bus) expansion slots, A-5

current requirements

- Venturis FX and Celebris FX low profile, A-6
- Venturis FX short tower, A-6

D

diskette and IDE devices

- connecting
 - Venturis FX and Celebris FX low profile, 6-15
 - Venturis FX short tower, 6-20

DMA channel assignment, B-6

E

ergonomics

- providing a comfortable working environment, 1-24

executing the BIOS Setup utility, 2-2

expansion boards

- installing, 5-6

expansion slots

- configuring, 5-1
- maximum current limitation, A-4

external devices

- disconnecting, 1-8

F

flash.exe utility, 2-19

forgetting your password, A-10

H

headphones

- connecting, 1-16

I

I/O Address Map, B-3

installing

- additional computer memory, 4-1
- optional wavetable daughter card, 4-13
- secondary cache module, 4-9

installing mass storage devices

- Venturis FX and Celebris FX low profile, 6-1
- Venturis FX short tower, 6-2

interrupt levels, B-5

IRQs, B-5

J

- jumper settings
 - main logic board, A-8
 - processor, A-9

M

- main logic board
 - connectors (rear panel), 3-6
- main logic board
 - jumper settings, A-8
- maneuvering through BIOS Setup utility, 2-4
- mapping
 - memory, B-2
- memory
 - mapping, B-2
 - video, 4-11
 - video, installing, 4-11
- memory mapping, B-2
- microphone
 - connecting, 1-17
- MIDI/joystick device
 - connecting, 1-22
- models
 - Venturis FX and Celebris FX, x

O

- optional wavetable daughter card, 4-13

P

- password
 - if your forget, A-10
- PCI-bus (local bus) expansion slots
 - maximum current limitation, A-5
- power cord requirements, A-7
- power requirements
 - Venturis FX and Celebris FX low profile, A-5
 - Venturis FX short tower, A-5

- prepare for expansion
 - computer, 3-2
- processor
 - jumper settings, A-9
 - replacing, 3-23

R

- removing the main logic board
 - Venturis FX short tower, 3-18

S

- secondary cache module
 - installing, 4-9
- SIMM
 - installing, 4-7
- speakers
 - connecting, 1-15
- specifications, A-2
 - computer, A-2
 - environmental, A-4
 - Venturis FX and Celebris FX low profile
 - dimensions, A-3
 - Venturis FX short tower dimensions, A-3

U

- USB device
 - connecting, 1-20
- using a Windows enhanced keyboard, 1-23
- utilities
 - flash.exe, 2-19

Index

V

- Venturis FX and Celebris FX low profile
 - 5¼-inch mass storage devices
 - installing, 6-5
 - diskette and IDE devices
 - connecting, 6-15
 - installing mass storage devices, 6-1
- Venturis FX and Celebris FX low profile expansion slot descriptions, 5-2
- Venturis FX and Celebris low profile expansion slots slot descriptions, 5-2
- Venturis FX Celebris FX low profile
 - system input power requirements, A-5
- Venturis FX low profile backplane
 - components and connectors, 3-10
- Venturis FX short tower
 - 3½-inch mass storage devices
 - installing, 6-7
 - diskette and IDE devices
 - connecting, 6-20
 - installing mass storage devices, 6-2

- system input power requirements, A-5
- Venturis FX short tower backplane
 - components and connectors, 3-14
- Venturis FX short tower expansion slot descriptions, 5-4
- Venturis FX short tower expansion slots
 - slot descriptions, 5-4
- Venturis FX short tower main logic board
 - removing, 3-18
- Venturis FXsm audio adapter card
 - connectors, 3-17
- video output information
 - computer, C-1
- VRM
 - installing, 3-25

W

- Windows enhanced keyboard
 - using, 1-23