

digital[™]

Venturis FX and Celebris FX

Service Maintenance Manual



VENTURIS FX and CELEBRIS FX

Venturis FX and Celebris FX

Service Maintenance Manual

Part Number: ER-BAAWW-SM. A01

VENTURIS FX and CELEBRIS FX

Digital Equipment Corporation

September 1996

The information in this document is subject to change without notice and should not be construed as a commitment by Digital Equipment Corporation.

Digital Equipment Corporation assumes no responsibility for any errors that might appear in this document.

The software described in this document is furnished under a license and may be used or copied only in accordance with the terms of such license. No responsibility is assumed for the use or reliability of software or equipment that is not supplied by Digital Equipment Corporation or its affiliated companies.

Restricted Rights: Use, duplication, or disclosure by the U.S. Government is subject to restrictions as set forth in subparagraph (c) (1) (ii) of the Rights in Technical Data and Computer Software clause at DFARS 252.227-7013.

Venturis FX and Celebris FX Service Maintenance Manual
Copyright© Digital Equipment Corporation.
All Rights Reserved.

DEC, Celebris, Venturis, and the Digital logo are registered trademarks of Digital Equipment Corporation

Intel is a registered trademark of Intel Corporation.

Pentium and Pentium-Pro are registered trademarks of Intel Corporation

Microsoft, Windows 95, and Windows NT are registered trademarks of Microsoft Corporation.

SIMM is a registered trademark of Wang Laboratories.

All other trademarks and registered trademarks are the property of their respective holders.

The FCC wants you to know...

This equipment has been tested and found to comply with the limits for a Class B digital device, pursuant to Part 15 of the FCC rules. These limits are designed to provide reasonable protection against harmful interference in a residential installation.

Any changes or modifications made to this equipment may void the user's authority to operate this equipment.

This equipment generates, uses, and can radiate radio frequency energy and, if not installed and used in accordance with the instructions, may cause harmful interference to radio communications. However, there is no guarantee that interference will not occur in a particular installation. If this equipment does cause harmful interference to radio or television reception, which can be determined by turning the equipment off and on, the user is encouraged to try to correct the interference by one or more of the following measures:

- Reorient or relocate the receiving antenna
- Increase the separation between the equipment and receiver
- Connect the equipment into an outlet on a circuit different from that to which the receiver is connected
- Consult the dealer or an experienced radio/TV technician for help

The user may find the following booklet prepared by the Federal Communications Commission helpful: How to Identify and Resolve Radio-TV Interference Problems. This booklet is available from the U.S. Government Printing Office, Washington, D.C., 20402. Stock No. 004-00398-5.

All external cables connecting to this basic unit need to be shielded. For cables connecting to option boards, see the option manual or installation instructions.

This digital apparatus does not exceed the Class B limits for radio noise emissions set out in the radio interference regulations of the Canadian Department of Communications.

This equipment is in the 2nd Class category (information equipment to be used in a residential area or an adjacent area thereto) and conforms to the standards set by the Voluntary Control Council For Interference by Data Processing Equipment and Electronic Office Machines aimed at preventing radio interference in such residential area.

When used near a radio or TV receiver, it may become the cause of radio interference.

Read the instructions for correct handling.

This equipment meets or exceeds requirements for safety in the U.S. (UL 1950), Canada (CSA C22.2 No. 950), and Europe (EN 60950/IEC 950) with Nordic requirements.

This equipment meets or exceeds the ergonomic requirements of ZH1/618 and is certified to bear the GS mark by TUV Rheinland of Germany.



WARNING: There is a danger of battery explosion if a lithium battery is incorrectly replaced. To prevent damage to your computer, be sure the + side faces up when installing a new battery. Also, be sure you replace the battery with either a Digital (P/N 12-41474-05), Toshiba (P/N CR2032), or equivalent 3 V dc lithium battery.

Depending on your locality, your computer's battery might be considered hazardous waste. Make sure you follow any state or local statute to properly dispose of the old battery.



ADVARSEL: Der er fare for, at et lithiumbatteri eksploderer, hvis det udskiftes ukorrekt. Undgå, at beskadige din computer - HUSK, at + siden skal vende opad, når du installerer et nyt batteri. Du skal udskifte batteriet med enten et Digital (delnummer 12-41474-05), Toshiba (delnummer CR2032), eller tilsvarende 3 V jævnstrøms lithiumbatteri.

Afhængig af dit lokalområde, er det muligt, at din computers batteri betragtes som farligt affald. Husk, at følge evt. miljølove og lokale bestemmelser, når du kasserer det gamle batteri.



VAROITUS: Litiumpatterit voivat räjähtää, jos ne asennetaan väärin. Estääksesi tietokoneesi vaurioitumisen varmista, että patteria asentaessasi sen positiivinen (+) puoli on ylöspäin. Tarkista myös, että käyttämäsi uusi patteri on joko Digital (osa no. 12-41474-05), Toshiba (osa no. CR2032) tai vastaavanlainen 3 voltin tasavirtalitiumpatteri.

Asuinpaikastasi riippuen tietokoneesi patteria voidaan pitää ongelmajätteenä. Pidä huoli, että hävität vanhan patterin voimassa olevien lakien ja asetusten mukaisesti.



WARNING! Det kan förekomma en batteriexplosion om ett litiumjonbatteri byts ut på felaktigt sätt. Förhindra att datorn skadas genom att se till att plussidan (+) är uppåtvänd när du sätter i ett nytt batteri. Det gamla batteriet får endast bytas ut mot ett Digital-batteri (artikelnummer 12-41454-05), ett Toshiba-batteri (artikelnummer CR2032) eller ett motsvarande litiumbatteri på 3 volt likström.

Datorbatterier anses vara miljöfarligt avfall i många länder. Du måste följa alla lokala bestämmelser när du avyttrar ett gammalt batteri.

Contents

Preface	vii
1	
Product Description	
Introduction	1-1
Product Model Numbers	1-2
Celebris FX Low Profile Model 1 Products	1-3
Celebris FX Products with 1 GB IDE HDDs	1-4
Celebris FX Products with 2 GB IDE HDDs	1-5
Celebris FX Products with Matrox Video	1-6
Venturis FX Multimedia Products with 845 GB IDE HDDs	1-7
Venturis FX Multimedia Products with 1.6 GB IDE HDDs	1-8
Venturis FX Multimedia Products with 2.4 GB IDE HDDs	1-9
Venturis FX Bid Box Products with 630 MB IDE HDDs	1-10
Venturis FX Bid Box Products with 845 MB IDE HDDs	1-11
Venturis FX Bid Box Products with 1.2 GB IDE HDDs	1-12
Venturis FX Low Profile Model 1 Products	1-13
Venturis FX Short Tower Model 1 Products	1-14
Venturis FX Low Profile with 845 MB IDE HDDs	1-15
Venturis FX Low Profile with 1.6 GB IDE HDDs	1-16
Venturis FX Low Profile with 2.4 GB IDE HDDs	1-17
Venturis FX Short Tower with 845 MB IDE HDDs	1-18
Venturis FX Short Tower with 1.6 GB IDE HDDs	1-19
Venturis FX Short Tower with 2.4 GB IDE HDDs	1-20
Related Material	1-21
Latest Product Information and Updates	1-22

2

BIOS Setup Utility

Running the BIOS Setup Utility.....	2-1
Helpful Hints.....	2-2
BIOS Setup Utility Options.....	2-3
Main.....	2-4
Advanced.....	2-10
Security Options.....	2-15
Power.....	2-18
Boot.....	2-20
Flash Utility.....	2-20

3

System Software

Introduction.....	3-1
Factory Installed Software.....	3-2
On-Line Documentation.....	3-2
Applications.....	3-3
Operating System Kit.....	3-6
Software Backup CD and Supplied Diskettes (Windows 95 and Windows NT Workstation).....	3-7
Configuring Video.....	3-8
Configuring Networking.....	3-8
Configuring Additional Hardware.....	3-8
Using Diagnostics.....	3-9
Restoring the Computer's Software.....	3-10
Additional Device Drivers.....	3-11

4

Troubleshooting

Initial Troubleshooting.....	4-1
Pass/Fail Criteria.....	4-3
Diagnostics.....	4-4
ClientWORKS and DMI.....	4-5
Advanced Troubleshooting.....	4-6
Computer Troubleshooting.....	4-7
Disk Drive Troubleshooting.....	4-21
Monitor Troubleshooting.....	4-23
Audio Troubleshooting.....	4-25

Network Interface Troubleshooting.....	4-27
CD-ROM Troubleshooting.....	4-28
Error Messages	4-29
POST Messages	4-29
POST and Boot Messages.....	4-30
POST Execution Messages.....	4-33
Beep Codes	4-34

5

FRU Replacement

Venturis FX and Celebris FX Low Profile FRU List	5-1
Enclosure	5-4
Storage Devices	5-5
Cables	5-6
Nameplates.....	5-7
Miscellaneous	5-8
Venturis FX Short Tower FRU List	5-9
Enclosure	5-12
Storage Devices	5-13
Cables	5-14
Nameplates.....	5-14
Miscellaneous	5-15
Service Procedures	5-16
Recommended Tools	5-17
Other Materials Needed	5-17
Special Tools Required	5-17
Remedial Diagnostic Test Software.....	5-18
Virus Software Information	5-18
BIOS Version Information.....	5-19
Disconnect External Devices and Power	5-19
Removing the Outside Cover	5-20
Computer Components.....	5-22
Main Logic Board Components.....	5-22
Main Logic Board Connectors (Rear Panel).....	5-24
Main Logic Board Connectors.....	5-26
Venturis FX Low Profile Backplane Components and Connectors	5-28
Celebris FX Low Profile Backplane Components and Connectors	5-30
Venturis FX Short Tower Backplane Components and Connectors	5-32
Expansion Slots (Venturis FX and Celebris FX Low Profile).....	5-34

Contents

Expansion Slots (Venturis FX Short Tower)	5-36
Main Logic Board Jumper Settings.....	5-38
Processor Jumper Settings.....	5-40
Installing Additional Computer Memory	5-40
Memory Configurations	5-42
Removing and Replacing Components	5-45
Removing the Main Logic Board	5-46
Removing an Adapter Card	5-48
Removing the SIMMs.....	5-50
Removing the Secondary Cache Module	5-51
Removing Video Memory.....	5-52
Removing a WaveTable Daughter Card.....	5-53
Removing the Lithium Battery.....	5-54
Removing the Processor Heat Sink	5-56
Removing the Processor.....	5-58
Removing the Voltage Regulator Module (VRM)	5-60
Removing the Backplane (Venturis FX and Celebris FX Low Profile).....	5-62
Removing the Backplane (Venturis FX Short Tower).....	5-64
Removing Expansion Boards	5-66
Removing the Power Supply (Venturis FX and Celebris FX Low Profile)	5-68
Removing the Power Supply (Venturis FX Short Tower)	5-70
Removing the Control Panel Assembly (Venturis FX and Celebris FX Low Profile) ..	5-72
Removing the Front Air Duct (Venturis FX Short Tower)	5-74
Removing the Control Panel Assembly and Cable (Venturis FX Short Tower).....	5-75
Removing the Option Card Assembly (Venturis FX Short Tower).....	5-77
Removing the Wire Assembly, Headphone/Microphone (Venturis FX Short Tower)	5-78
Removing a 3½-Inch Device from Front Bay (Venturis FX and Celebris FX Low Profile)	5-80
Removing a 5¼-Inch Device (Venturis FX and Celebris FX Low Profile)	5-82
IDE Drive Connections (Venturis FX and Celebris FX Low Profile).....	5-84
Removing the Internal 3½-Inch Device (Venturis FX and Celebris FX Low Profile)...	5-86
Removing the Diskette Drive (Venturis FX and Celebris FX Low Profile)	5-88
Diskette Drive Connections (Venturis FX and Celebris FX Low Profile)	5-90
Removing the Front Bezel (Venturis FX Short Tower)	5-92
Removing a 3½-Inch Device from Front Bay (Venturis FX Short Tower)	5-94
Removing a 5¼-Inch Device (Venturis FX Short Tower)	5-96
Removing an Internal 3½-Inch Device (Venturis FX Short Tower).....	5-98
IDE Drive Connections (Venturis FX Short Tower)	5-100
Removing the Diskette Drive (Venturis FX Short Tower).....	5-102
Diskette Drive Connections (Venturis FX Short Tower)	5-104

6

Device Mapping

Introduction	6-1
CPU Memory Address Map (Full Range).....	6-2
I/O Address Map.....	6-3
Computer Interrupt Levels.....	6-5
DMA Channel Assignment.....	6-6

Service Notes	A-1
----------------------------	-----

Figures

5-1. Venturis FX and Celebris FX Low Profile.....	5-2
5-2. Venturis FX Short Tower.....	5-10
5-3. Removing the Outside Cover	5-21
5-4. Main Logic Board Components	5-23
5-5. Main Logic Board Components (Rear Panel).....	5-25
5-6. Main Logic Board Connectors	5-27
5-7. Venturis FX Low Profile Backplane Components and Connectors.....	5-29
5-8. Celebris FX Low Profile Backplane Components and Connectors.....	5-31
5-9. Venturis FX Short Tower Backplane Components and Connectors	5-33
5-10. Expansion Board Slots (Venturis FX and Celebris FX Low Profile)	5-35
5-11. Expansion Board Slots (Venturis FX Short Tower)	5-37
5-12. Main Logic Board Jumper Locations.....	5-39
5-13. SIMM Socket Locations for Most Models (Some Models Have 4 SIMM Sockets).....	5-41
5-14. Removing the Main Logic Board	5-47
5-15. Removing an Adapter Card	5-49
5-16. Removing SIMMs.....	5-50
5-17. Removing a Secondary Cache Module	5-51
5-18. Removing Video Memory	5-52
5-19. Removing a WaveTable Daughter Card.....	5-53
5-20. Removing the Lithium Battery	5-55
5-21. Removing the Processor Heat Sink	5-57
5-22. Removing the Processor Heat Sink	5-59
5-23. Removing the VRM.....	5-61
5-24. Removing the Backplane (Venturis FX and Celebris FX Low Profile)	5-63
5-25. Removing the Backplane (Venturis FX Short Tower)	5-65
5-26. Removing Expansion Boards.....	5-67
5-27. Removing the Power Supply (Venturis FX and Celebris FX Low Profile).....	5-69
5-28. Removing the Power Supply (Venturis FX Short Tower).....	5-71

VENTURIS FX and CELEBRIS FX

Contents

5-29. Removing the Control Panel Assembly (Venturis FX and Celebris FX Low Profile)	5-73
5-30. Removing the Front Air Duct (Venturis FX Short Tower)	5-74
5-31. Removing the Control Panel Assembly and Cable (Venturis FX Short Tower) ...	5-76
5-32. Removing the Option Card Assembly (Venturis FX Short Tower)	5-77
5-33. Removing the Wire Assembly, Headphone/Microphone (Venturis FX Short Tower)	5-79
5-34. Removing a 3½-Inch Device from Front Bay (Venturis FX and Celebris FX Low Profile)	5-81
5-35. Removing a 5¼-Inch Device (Venturis FX and Celebris FX Low Profile)	5-83
5-36. IDE Drive Connections (Venturis FX and Celebris FX Low Profile)	5-85
5-37. Removing the Internal 3½-Inch Device (Venturis FX and Celebris FX Low Profile)	5-87
5-38. Removing the Diskette Drive (Venturis FX and Celebris FX Low Profile)	5-89
5-39. Diskette Drive Connections (Venturis FX and Celebris FX Low Profile)	5-91
5-40. Removing the Front Bezel	5-93
5-41. Removing a 3½-Inch Device from Front Bay (Venturis FX Short Tower)	5-95
5-42. Removing a 5¼-Inch Device (Venturis FX Short Tower)	5-97
5-43. Removing an Internal 3½-Inch Device (Venturis FX Short Tower)	5-99
5-44. IDE Drive Connections (Venturis FX Short Tower)	5-101
5-45. Removing the Diskette Drive (Venturis FX Short Tower)	5-103
5-46. Diskette Drive Connections (Venturis FX Short Tower)	5-105

Preface *P*

This *Service Maintenance Manual* is a troubleshooting guide that can be used for reference when servicing Venturis FX and Celebris FX computers.

Digital reserves the right to make changes to this *Service Maintenance Manual* without notice. Accordingly, the illustrations and procedures in this document might not apply to all Venturis FX and Celebris FX computers to be serviced since many of the diagnostic tests are designed to test more than one product.



CAUTION: Digital recommends that only A+ certified engineers attempt to repair this equipment. All troubleshooting and repair procedures are detailed to support subassembly/module level exchange. Because of the complexity of the individual boards and subassemblies, no one should attempt to make repairs at the component level or make modifications to any printed circuit board. Improper repairs can create a safety hazard. Any indications of component replacement or circuit board modifications might void any warranty or exchange allowances.

Product Description **1**

Introduction

Venturis FX and Celebris FX computers are high-performance personnel computers featuring the latest in computing technology. They can be used as stand-alone computers, as clients, or as servers in a network environment. Developed using the following state-of-the-art technology, these computers are the most value packed computers in their class.

- *Microprocessor*— Pentium processor at 75, 100, 120, 133, 166, or 200 MHz with 256 KB external cache (most models)
- *Memory*— At least 8 MB of EDO DRAM standard, expandable up to 192 MB using 32 MB SIMMs. For Venturis FXe models, at least 8 MB of EDO DRAM standard, expandable up to 128 MB using 32 MB SIMMs
- *Plug and Play*— Optional Plug and Play compatible expansion boards are automatically configured for easy installation.
- *PCI local bus*— The computer's PCI architecture represents the latest in local bus technology.

Product Description

- *Onboard video*— S3 64-bit graphics controller supports 2D performance using DRAM-based technology. Built-in video playback acceleration to enhance multimedia applications. 1 MB DRAM standard, expandable up to 2 MB. Note that Venturis FXe models only come with 1 MB of DRAM and are not expandable. Also note that Venturis FXsm models come standard with 2 MB of DRAM and are not expandable.
- *Onboard Ethernet*— On Celebris FX models, single 21040 Ethernet controller for PCI bus: PCI bus clock up to 33 MHz, independent of network clock. Full duplex operation supports IEEE, ANSI, and Ethernet standards. Offers a 10Base-T connection to corporate networks.
- *Onboard audio*— On Venturis FXsm models, 16-bit stereo sound circuit supports business and SoundBlaster Pro applications. 20 voice FM music synthesizer. The internal computer speaker is connected to the audio system with volume control (selected in the BIOS Setup utility) as the default output device.

Product Model Numbers

The following sections provide product part numbers. In all cases the model description describes the Pentium processors that ship with computers. For example, 5133 LP models come with a 133 MHz Pentium processor.

Celebris FX Low Profile Model 1 Products

The following products all come with:

- A 3½-inch 1.44 MB diskette drive
- 256 KB of external cache
- 16 MB of memory
- S3 Trio 64V+ video
- No hard disk drive

Part Number	Description	Additional Features
FR-BA0AX-B1	5133 LP	U.S. Model 1 Country Kit, Media Kit
FR-BA0JX-B1	5133 LP	Japanese Model 1 Country Kit, Media Kit
FR-BA0WW-B1	5133 LP	Country Kit Required, Media Kit
FR-BA1AX-B1	5166 LP	U.S. Model 1 Country Kit, Media Kit
FR-BA1JX-B1	5166 LP	Japanese Model 1 Country Kit, Media Kit
FR-BA1WW-B1	5166 LP	Country Kit Required, Media Kit
FR-BA2AX-B1	5200 LP	U.S. Model 1 Country Kit, Media Kit
FR-BA2JX-B1	5200 LP	Japanese Model 1 Country Kit, Media Kit
FR-BA2WW-B1	5200 LP	Country Kit Required, Media Kit

VENTURIS FX and CELEBRIS FX

Celebris FX Products with 1 GB IDE HDDs

The following products all come with:

- A 3½-inch 1.44 MB diskette drive
- 256 KB of external cache
- 16 MB of memory
- S3 Trio 64V+ video
- 8x CD-ROM drive (Japanese products only)
- 1 GB IDE hard disk drive

VENTURIS FX and CELEBRIS FX

Part Number	Description	Additional Features
FR-BA0AC-BA	5133 LP	U.S. Country Kit, Windows 95
FR-BA0AN-BA	5133 LP	U.S. Country Kit, Windows NT V3.51
FR-BA0AP-BA	5133 LP	U.S. Country Kit, Windows NT V4.0
FR-BA0WW-BA	5133 LP	Country Kit Required
FR-BA0JC-DA	5133 LP	Japanese Country Kit, Windows 95
FR-BA0JN-DA	5133 LP	Japanese Country Kit, Windows NT V3.51
FR-BA0JP-DA	5133 LP	Japanese Country Kit, Windows NT V4.0
FR-BA1AC-BA	5166 LP	U.S. Country Kit, Windows 95
FR-BA1AN-BA	5166 LP	U.S. Country Kit, Windows NT V3.51
FR-BA1AP-BA	5166 LP	U.S. Country Kit, Windows NT V4.0
FR-BA1WW-BA	5166 LP	Country Kit Required
FR-BA1JC-DA	5166 LP	Japanese Country Kit, Windows 95
FR-BA1JN-DA	5166 LP	Japanese Country Kit, Windows NT V3.51
FR-BA1JP-DA	5166 LP	Japanese Country Kit, Windows NT V4.0
FR-BA2AC-BA	5200 LP	U.S. Country Kit, Windows 95
FR-BA2AN-BA	5200 LP	U.S. Country Kit, Windows NT V3.51
FR-BA2AP-BA	5200 LP	U.S. Country Kit, Windows NT V4.0
FR-BA2WW-BA	5166 LP	Country Kit Required
FR-BA2JC-DA	5200 LP	Japanese Country Kit, Windows 95
FR-BA2JN-DA	5200 LP	Japanese Country Kit, Windows NT V3.51
FR-BA2JP-DA	5200 LP	Japanese Country Kit, Windows NT V4.0

Celebris FX Products with 2 GB IDE HDDs

The following products all come with:

- A 3½-inch 1.44 MB diskette drive
- 256 KB of external cache
- 16 MB of memory
- S3 Trio 64V+ video
- 8x CD-ROM drive
- 2 GB IDE hard disk drive

Part Number	Description	Additional Features
FR-BA1AC-DB	5166 LP	U.S. Country Kit, Windows 95
FR-BA1AN-DB	5166 LP	U.S. Country Kit, Windows NT V3.51
FR-BA1AP-DB	5166 LP	U.S. Country Kit, Windows NT V4.0
FR-BA1WW-DB	5166 LP	Country Kit Required
FR-BA1JC-DB	5166 LP	Japanese Country Kit, Windows 95
FR-BA1JN-DB	5166 LP	Japanese Country Kit, Windows NT V3.51
FR-BA1JP-DB	5166 LP	Japanese Country Kit, Windows NT V4.0
FR-BA2AC-DB	5200 LP	U.S. Country Kit, Windows 95
FR-BA2AN-DB	5200 LP	U.S. Country Kit, Windows NT V3.51
FR-BA2AP-DB	5200 LP	U.S. Country Kit, Windows NT V4.0
FR-BA2WW-DB	5200 LP	Country Kit Required
FR-BA2JC-DB	5200 LP	Japanese Country Kit, Windows 95
FR-BA2JN-DB	5200 LP	Japanese Country Kit, Windows NT V3.51
FR-BA2JP-DB	5200 LP	Japanese Country Kit, Windows NT V4.0

VENTURIS FX and CELEBRIS FX

Celebris FX Products with Matrox Video

The following products all come with:

- A 3½-inch 1.44 MB diskette drive
- 256 KB of external cache
- 16 MB of memory
- 1 GB IDE hard disk drive
- 8x CD-ROM drive
- Matrox video card

VENTURIS FX and CELEBRIS FX

Part Number	Description	Additional Features
FR-BA1WW-HB	5166 LP	Country Kit Required
FR-BA2WW-HB	5200 LP	Country Kit Required

Venturis FX Multimedia Products with 845 GB IDE HDDs

The following products all come with:

- A 3½-inch 1.44 MB diskette drive
- 256 KB of external cache
- 16 MB of memory
- S3 Trio 64+ video with 2 MB of video RAM
- 6x CD-ROM drive
- 845 MB IDE hard disk drive
- Advanced audio
- Microphone and headset

Part Number	Description	Additional Features
FR-AA1AW-HB	5100SM	U.S. Country Kit, Windows 95
FR-AA1WW-HB	5100SM	Country Kit Required

VENTURIS FX and CELEBRIS FX

Venturis FX Multimedia Products with 1.6 GB IDE HDDs

The following products all come with:

- A 3½-inch 1.44 MB diskette drive
- 256 KB of external cache
- 16 MB of memory
- S3 Trio 64+ video with 2 MB of video RAM
- 6x CD-ROM drive
- 1.6 GB IDE hard disk drive
- Advanced audio
- Microphone and headset

Part Number	Description	Additional Features
FR-AA1AW-HD	5100SM	U.S. Country Kit, Windows 95
FR-AA1WW-HD	5100SM	Country Kit Required
FR-AA3AW-HD	5133SM	U.S. Country Kit, Windows 95
FR-AA3WW-HD	5133SM	Country Kit Required
FR-AA5AW-HD	5166SM	U.S. Country Kit, Windows 95
FR-AA5WW-HD	5166SM	Country Kit Required

Venturis FX Multimedia Products with 2.4 GB IDE HDDs

The following products all come with:

- A 3½-inch 1.44 MB diskette drive
- 256 KB of external cache
- 16 MB of memory
- S3 Trio 64+ video with 2 MB of video RAM
- 6x CD-ROM drive
- 2.4 GB IDE hard disk drive
- Advanced audio
- Microphone and headset

Part Number	Description	Additional Features
FR-AA1AW-HE	5100SM	U.S. Country Kit, Windows 95
FR-AA1WW-HE	5100SM	Country Kit Required
FR-AA3AW-HE	5133SM	U.S. Country Kit, Windows 95
FR-AA3WW-HE	5133SM	Country Kit Required
FR-AA5AW-HE	5166SM	U.S. Country Kit, Windows 95
FR-AA5WW-HE	5166SM	Country Kit Required

VENTURIS FX and CELEBRIS FX

Venturis FX Bid Box Products with 630 MB IDE HDDs

The following products all come with:

- A 3½-inch 1.44 MB diskette drive (except FR-AB0AW-EA and FR-AB0WW-EA)
- No external cache
- 8 MB of memory
- S3 Trio 64 video
- 630 MB IDE hard disk drive

VENTURIS FX and CELEBRIS FX

Part Number	Description	Additional Features
FR-AB0AW-AA	575E	U.S. Country Kit, Windows 95
FR-AB0AW-EA	575E	U.S. Country Kit, Windows 95
FR-AB0WW-AA	575E	Country Kit Required
FR-AB0WW-EA	575E	Country Kit Required
FR-AB1AW-AA	5100E	U.S. Country Kit, Windows 95
FR-AB1WW-AA	5100E	Country Kit Required

Venturis FX Bid Box Products with 845 MB IDE HDDs

The following products all come with:

- A 3½-inch 1.44 MB diskette drive
- No external cache
- 8 MB of memory
- S3 Trio 64 video
- 845 MB IDE hard disk drive

Part Number	Description	Additional Features
FR-AB0AW-AB	575E	U.S. Country Kit, Windows 95
FR-AB0WW-AB	575E	Country Kit Required
FR-AB1AW-AB	5100E	U.S. Country Kit, Windows 95
FR-AB1WW-AB	5100E	Country Kit Required
FR-AB2AC-AB	5120E	U.S. Country Kit, Windows 95
FR-AB2WW-AB	5120E	Country Kit Required

VENTURIS FX and CELEBRIS FX

Venturis FX Bid Box Products with 1.2 GB IDE HDDs

The following products all come with:

- A 3½-inch 1.44 MB diskette drive
- No external cache
- 8 MB of memory
- S3 Trio 64 video
- 1.2 GB IDE hard disk drive

VENTURIS FX and CELEBRIS FX

Part Number	Description	Additional Features
FR-AB0AW-AC	575E	U.S. Country Kit, Windows 95
FR-AB0WW-AC	575E	Country Kit Required
FR-AB1AW-AC	5100E	U.S. Country Kit, Windows 95
FR-AB1WW-AC	5100E	Country Kit Required

Venturis FX Low Profile Model 1 Products

The following products all come with:

- A 3½-inch 1.44 MB diskette drive
- No external cache
- 8 MB of memory
- S3 Trio 64V+ video
- No hard disk drive

Part Number	Description	Additional Features
FR-A70AX-A1	575 LP	U.S. Model 1 Country Kit, Media Kit
FR-A70WW-A1	575 LP	Country Kit Required, Medial Kit
FR-A71AX-A1	5100 LP	U.S. Model 1 Country Kit, Media Kit
FR-A71WW-A1	5100 LP	Country Kit Required, Medial Kit
FR-A72WW-A1	5120 LP	Country Kit Required, Medial Kit
FR-A73AX-A1	5133 LP	U.S. Model 1 Country Kit, Media Kit
FR-A73WW-A1	5133 LP	Country Kit Required, Medial Kit
FR-A74AX-A1	5150 LP	U.S. Model 1 Country Kit, Media Kit
FR-A74WW-A1	5150 LP	Country Kit Required, Medial Kit
FR-A75AX-A1	5166 LP	U.S. Model 1 Country Kit, Media Kit
FR-A75WW-A1	5166 LP	Country Kit Required, Medial Kit

VENTURIS FX and CELEBRIS FX

Venturis FX Short Tower Model 1 Products

The following products all come with:

- A 3½-inch 1.44 MB diskette drive
- No external cache
- 8 MB of memory
- S3 Trio 64V+ video
- No hard disk drive

VENTURIS FX and CELEBRIS FX

Part Number	Description	Additional Features
FR-A81AX-A1	5100 ST	U.S. Model 1 Country Kit, Media Kit
FR-A81WW-A1	5100 ST	Country Kit Required, Media Kit
FR-A83AX-A1	5133 ST	U.S. Model 1 Country Kit, Media Kit
FR-A83WW-A1	5133 ST	Country Kit Required, Media Kit
FR-A85AX-A1	5166 ST	U.S. Model 1 Country Kit, Media Kit
FR-A85WW-A1	5166 ST	Country Kit Required, Media Kit

Venturis FX Low Profile with 845 MB IDE HDDs

The following products all come with:

- A 3½-inch 1.44 MB diskette drive (not available for all models)
- 256 KB external cache
- 8 MB of memory
- S3 Trio 64V+ video
- 6x CD-ROM drive (not available on all models)
- 845 MB IDE hard disk drive

Part Number	Description	Additional Features
FR-A70AW-EB ⁽¹⁾	575 LP	U.S. Country Kit, Windows 95
FR-A70WW-AB	575 LP	Country Kit Required
FR-A70WW-EB ⁽¹⁾	575 LP	Country Kit Required
FR-A71AW-AB	5100 LP	U.S. Country Kit, Windows 95
FR-A71AW-EB ⁽¹⁾	5100 LP	U.S. Country Kit, Windows 95
FR-A71WW-AB	5100 LP	Country Kit Required
FR-A71WW-EB ⁽¹⁾	5100 LP	Country Kit Required
FR-A71WW-GB ⁽²⁾	5100 LP	Country Kit Required
FR-A72AW-EB ⁽¹⁾	5120 LP	U.S. Country Kit, Windows 95
FR-A72WW-AB	5120 LP	Country Kit Required
FR-A72WW-EB ⁽¹⁾	5120 LP	Country Kit Required
FR-A73AW-EB ⁽¹⁾	5133 LP	U.S. Country Kit, Windows 95
FR-A73WW-AB	5133 LP	Country Kit Required
FR-A73WW-EB ⁽¹⁾	5133 LP	Country Kit Required
FR-A73WW-GB ⁽²⁾	5133 LP	Country Kit Required
FR-A75WW-GB ⁽²⁾	5166 LP	Country Kit Required

⁽¹⁾ 3½-inch 1.44 MB diskette drive not included

⁽²⁾ 6x CD-ROM included

Venturis FX Low Profile with 1.6 GB IDE HDDs

The following products all come with:

- A 3½-inch 1.44 MB diskette drive
- 256 KB external cache
- 16 MB of memory
- S3 Trio 64V+ video
- 1.6 GB IDE hard disk drive

VENTURIS FX and CELEBRIS FX

Part Number	Description	Additional Features
FR-A71AW-BD	5100 LP	U.S. Country Kit, Windows 95
FR-A71WW-BD	5100 LP	Country Kit Required
FR-A72AW-BD	5120 LP	U.S. Country Kit, Windows 95
FR-A72WW-BD	5120 LP	Country Kit Required
FR-A73AW-BD	5133 LP	U.S. Country Kit, Windows 95
FR-A73WW-BD	5133 LP	Country Kit Required
FR-A74AW-BD	5150 LP	U.S. Country Kit, Windows 95
FR-A74WW-BD	5150 LP	Country Kit Required
FR-A75AW-BD	5166 LP	U.S. Country Kit, Windows 95
FR-A75WW-BD	5166 LP	Country Kit Required

Venturis FX Low Profile with 2.4 GB IDE HDDs

The following products all come with:

- A 3½-inch 1.44 MB diskette drive
- 256 KB external cache
- 16 MB of memory
- S3 Trio 64V+ video
- 2.4 GB IDE hard disk drive

Part Number	Description	Additional Features
FR-A71AW-BE	5100 LP	U.S. Country Kit, Windows 95
FR-A71WW-BE	5100 LP	Country Kit Required
FR-A72AW-BE	5120 LP	U.S. Country Kit, Windows 95
FR-A72WW-BE	5120 LP	Country Kit Required
FR-A73AW-BE	5133 LP	U.S. Country Kit, Windows 95
FR-A73WW-BE	5133 LP	Country Kit Required
FR-A74AW-BE	5150 LP	U.S. Country Kit, Windows 95
FR-A74WW-BE	5150 LP	Country Kit Required
FR-A75AW-BE	5166 LP	U.S. Country Kit, Windows 95
FR-A75WW-BE	5166 LP	Country Kit Required

VENTURIS FX and CELEBRIS FX

Venturis FX Short Tower with 845 MB IDE HDDs

The following products all come with:

- A 3½-inch 1.44 MB diskette drive
- 256 KB external cache
- 8 MB of memory
- S3 Trio 64V+ video
- 6x CD-ROM drive (not available on all models)
- 845 MB IDE hard disk drive

VENTURIS FX and CELEBRIS FX

Part Number	Description	Additional Features
FR-A80AW-AB	575 ST	U.S. Country Kit, Windows 95
FR-A80WW-AB	575 ST	Country Kit Required
FR-A81WW-AB	5100 ST	Country Kit Required
FR-A81WW-GB ⁽¹⁾	5100 ST	Country Kit Required
FR-A83WW-GB ⁽¹⁾	5133 ST	Country Kit Required
FR-A85WW-GB ⁽¹⁾	5166 ST	Country Kit Required

⁽¹⁾ 6x CD-ROM included

Venturis FX Short Tower with 1.6 GB IDE HDDs

The following products all come with:

- A 3½-inch 1.44 MB diskette drive
- 256 KB external cache
- 16 MB of memory
- S3 Trio 64V+ video
- 1.6 GB IDE hard disk drive

Part Number	Description	Additional Features
FR-A81AW-BD	5100 ST	U.S. Country Kit, Windows 95
FR-A81WW-BD	5100 ST	Country Kit Required
FR-A82AW-BD	5120 ST	U.S. Country Kit, Windows 95
FR-A83AW-BD	5133 ST	U.S. Country Kit, Windows 95
FR-A83WW-BD	5133 ST	Country Kit Required
FR-A84WW-BD	5150 ST	Country Kit Required
FR-A85AW-BD	5166 ST	U.S. Country Kit, Windows 95
FR-A85WW-BD	5166 ST	Country Kit Required

VENTURIS FX and CELEBRIS FX

Venturis FX Short Tower with 2.4 GB IDE HDDs

The following products all come with:

- A 3½-inch 1.44 MB diskette drive
- 256 KB external cache
- 16 MB of memory
- S3 Trio 64V+ video
- 2.4 GB IDE hard disk drive

VENTURIS FX and CELEBRIS FX

Part Number	Description	Additional Features
FR-A81AW-BE	5100 ST	U.S. Country Kit, Windows 95
FR-A81WW-BE	5100 ST	Country Kit Required
FR-A82AW-BE	5120 ST	U.S. Country Kit, Windows 95
FR-A83AW-BE	5133 ST	U.S. Country Kit, Windows 95
FR-A83WW-BE	5133 ST	Country Kit Required
FR-A84WW-BE	5150 ST	Country Kit Required
FR-A85AW-BE	5166 ST	U.S. Country Kit, Windows 95
FR-A85WW-BE	5166 ST	Country Kit Required

Related Material

The following related material is available:

Document Title	Order Number	Description
Service Quick Reference	ER-BAAWW-SR	Provides troubleshooting information that can be used when servicing Venturis FX and Celebris FX computers.
Quick Setup Guide	ER-BAAWW-IM (Multilanguage)* ER-BAAWW-IJ (Japanese)	Describes how to initially setup Venturis FX and Celebris FX computers.
System Reference	ER-BAAWW-UA (English) ER-BAAWW-UJ (Japanese)	Describes how to operate, configure, and upgrade Venturis FX and Celebris FX computers.
System Solutions	ER-PCDSS-UA (English) ER-PCDSS-UM (Multilanguage)* ER-PCDSS-UJ (Japanese)	Provides end-user troubleshooting information should a Venturis FX or Celebris FX computer fail to operate after initial setup or after installing optional devices.
System Software	ER-B00WW-GA (English) ER-B00WW-GM (Multilanguage)*	Provides information on the operating system, utilities, and device drivers that came with Venturis FX and Celebris FX computers.
Warranty and Service	EK-PCHWW-CM (Multilanguage)*	Provides warranty information and a listing of phone numbers for technical support.
Backup Media Kit	QC-04J8A-HW QC-04K8A-HW	Celebris FX Backup Media Kit. Venturis FX Backup Media Kit.

* Multilanguage includes: English, French, Italian, German, and Spanish.

Product Description

README files come with the factory installed software and on the supplied backup CD-ROM disk. These files contain useful setup, configuration, and operation information. Read this information first.

Latest Product Information and Updates

You can access product information and download the latest BIOS, device drivers, and software updates using the Internet at:

- <http://www.pc.digital.com>
- <http://www.pc.digital.com/~ftp>

You can also access software updates through Digital's Bulletin Board Service (BBS) by calling:

In the United States: (508) 496-8800

Digital hosts a number of conferences on CompuServe featuring a wide range of topics. Enter GO DEC to reach Digital's main menu page. For information on PC integration, enter: GO DEC PC.

BIOS Setup Utility **2**

Running the BIOS Setup Utility

The BIOS Setup utility enables you to select and store permanently information about the computer's hardware and software in the battery-backed memory of the CMOS RAM. This information takes effect each time the computer boots and can be changed any time you run setup.

You should use the BIOS Setup utility if you experience problems with the hard disk or if you need to reconfigure or expand the computer. In addition, the BIOS Setup utility might need to be used to modify the configuration after adding or removing hardware, or changing computer settings.



CAUTION: The computer was setup for normal operation at the factory and will operate properly without additional configuring.

It is important for you to read carefully and understand this chapter before attempting to modify the computer's factory settings. Changing some settings might cause the computer to operate improperly.

To access the BIOS Setup utility, perform the following steps:

1. Turn on the computer and allow the Power-On Self Test (POST) to complete.
2. Make a note of any configuration errors listed, and then press [F2] to display the Main menu.
3. Follow the instructions on the monitor screen and any on-line help pop-up screens to configure you computer.

Helpful Hints

- Several keyboard keys are assigned to help you select menus and sub-menus, options, change option values, and display help information. These keys are displayed at the bottom of the main menu and from the General Help pop-up screen.
- Item-specific help is available anytime during the setup process and appears at the right of the setup screen when an option is highlighted. This on-line help provides information about a highlighted option.
- Select *Save Changes & Exit* to save all Setup values.
- Select *Discard Changes & Exit* to exit Setup without recording any changes.
- Select *Get Default Values* to set all Setup options to their default values.
- Select *Load Previous Changes* to restore all CMOS values from the last session.
- Select *Save Changes* to save all selections without exiting Setup.
- Press [Esc] to exit the BIOS Setup utility.

BIOS Setup Utility Options

The following Help topics list the BIOS options that can be updated or modified by using the BIOS Setup utility, according to the various sub-menus under which they appear.

- Main Menu Options — Sets basic computer configuration options (time, date, video, etc.).
- Advanced Options — Sets advanced features to increase computer performance (COM ports, LPT ports, etc.).
- Security Options — Sets passwords and backup data reminders.
- Power Options — Sets power saving options to increase the life of the computer.
- Boot Options — Sets the boot sequence for devices.
- Exit — Provides options for saving changes and leaving the BIOS Setup utility. Refer to “Navigating,” in the BIOS Setup utility, for additional information.



NOTE: The following tables list the BIOS Setup Menu options available for Venturis FX and Celebris FX computers. Note that an “*” that follows an option in the Settings column indicates the factory default setting.

Main

Menu Fields	Settings	Comments
System time	Current time	Displays the current time.
System date	Current date	Displays the current date.
Language	English* Español Français Deutsch Italiano	Language default depends on the language of the factory installed software. Two languages are available at a time, for example, English and French. You can then switch between the two languages. To switch to another supported BIOS language, you must flash the BIOS.
Diskette drive A/ Diskette drive B	1.44 MB, 3½* 2.88 MB, 3½ Not Installed* 360 KB, 5¼ 1.2 MB, 5¼ 720 KB, 3½	Sets the size and density of diskette drives.

IDE Adapter 0/1 Master/Slave

Autotype fixed disk	[Press Enter]	Press [Enter] to detect and fill in the installed hard disk drive parameters in the remaining fields.
Type ⁽¹⁾	None* 1 to 14 Rsrv 16 to 39 User Auto CD	<p>Selecting 1 to 14 and 16 to 39 automatically fills in the remaining fields in this menu.</p> <p>Selecting <i>User</i> enables the remaining fields to be filled in manually, using the installed hard disk drive's parameters.⁽²⁾</p> <p>If a CD-ROM reader is used for the IDE drive, you must select <i>CD</i>. You can select <i>Auto</i> for an HDD.</p>

⁽¹⁾ These fields are automatically filled in if your computer auto-detected an installed hard disk drive.

⁽²⁾ Incorrect settings can cause the computer to malfunction.

continued

Menu Fields	Settings	Comments
Cylinders ⁽¹⁾	0 to 4095	Displays the number of cylinders.
Heads ⁽¹⁾	1 to 64	Displays the number of heads.
Sectors/track ⁽¹⁾	0 to 63	Displays the number of sectors/track.
Write precomp ⁽¹⁾	0 to 4095 None	Displays the number of cylinders that have their write timing changed.
Multi-sector transfers	Disabled* 2 sectors 4 sectors 8 sectors 16 sectors Auto	Determines the number of sectors per block for multiple sector transfers. Auto refers to the size the disk returns when queried.
LBA control mode	Disabled* Enabled	Enabling this option causes Logical Block Addressing (LBA) instead of cylinders and heads. Select Disabled for IDE hard disk drives that are up to 528 MB in size. When using an IDE drive larger than 528 MB and an operating system that supports LBA, select Enable. MS-DOS and Windows are examples of operating systems that support LBA.
32-bit I/O	Enabled Disabled*	Enables or disables the 32-bit, hard disk drive data transfer option. Enabling this option speeds up data transfers; ensure that your HDD supports 32-bit I/O transfers.
Transfer mode	Standard* Fast PIO1 Fast PIO2 Fast PIO3 Fast PIO4	Selects the method to transfer data to and from the HDD. If you select the user autotype for the HDD, Setup automatically selects the optimum transfer mode is selected.
Video system	EGA / VGA* CGA 80x25 Monochrome	Sets the video controller type.

⁽¹⁾ These fields are automatically filled in if the computer auto-detected an installed hard disk drive.

continued

Menu Fields	Settings	Comments
Memory and Cache:		
Internal cache	Enabled* Disabled	Enables or disables the processor's internal cache.
External cache (if installed)	Enabled* Disabled	Your computer's external cache operates in write-back mode if you select <i>Enabled</i> . Your computer automatically detects if an external cache is or is not installed and sets the appropriate setting.
System BIOS shadow	Enabled*	Always set to <i>Enabled</i> .
Cache system BIOS	Enabled* Disabled	This option enables the system BIOS to be cached in the internal cache and external cache (if installed). This increases computer performance because BIOS instructions can be executed in cache instead of RAM. <i>Enabled</i> is the recommended setting.

continued

Menu Fields	Settings	Comments
Video BIOS shadow	Enabled* Disabled	The main logic board reserves an area of DRAM for a copy of video BIOS ROM. This DRAM called "shadow memory" is write-protected and has the same addresses as the video BIOS ROM locations. When video BIOS ROM is shadowed, the ROM information is copied into an appropriate area in DRAM. This increases the computer's performance because the video BIOS instructions are in fast DRAM instead of ROM. Enabled is the recommended setting.
Cache video BIOS	Enabled* Disabled	This option enables the video BIOS to be cached in the internal cache and external cache (if installed). This increases computer performance because video BIOS instructions can be executed in cache instead of RAM. Enabled is the recommended setting.
Shadow 16K at: C8000h CC000h D0000h D4000h D8000h DC000h	Enabled Disabled*	Enables or disables shadowing of individual segments of ROM to increase computer performance. CAUTION: Some option ROMs do not operate properly when shadowed.

continued

VENTURIS FX and CELEBRIS FX

Menu Fields	Settings	Comments
AT bus space	Disabled*	Memory hole not available; upper memory is contiguous.
	F80000h, 0.5 MB	Sets the memory hole at address F80000 with 0.5 MB memory available. Note that this memory hole is reserved by some network cards.
	F00000h, 1 MB	Sets the memory hole at address F00000 with 1 MB memory available.
Extended memory report	Compatibility*	Select the BIOS report mechanism for the amount of external memory. Select <i>Compatibility</i> when using a conventional operating system.
	Non-compatibility	Select <i>Non-compatibility</i> for extended memory above 64 MB under Windows NT.
Boot Options		
Summary screen	Enabled*	Enabling this option causes the computer to display configuration parameters (in the form of a summary screen) during boot.
	Disabled	
Quiet boot	Enabled	Enables or disables the display of POST messages. Quiet Boot, when enabled, displays the Digital logo, instead of POST messages.
	Disabled*	
Floppy check	Enabled*	Enabled permits verification of FDD type at boot. Disabled prevents FDD verification and speeds up the boot process.
	Disabled	

continued

Menu Fields	Settings	Comments
Keyboard Features		
NumLock	Auto* On Off	Turns NumLock on or off each time the computer boots. If <code>Auto</code> is selected, the computer will turn on NumLock if it detects a numeric keypad.
Key click	Disabled* Enabled	Enables or disables the audible key click feature.
Keyboard auto-repeat rate	2/sec 6/sec 10/sec 13.3/sec 18.5/sec 21.8/sec 26.7/sec 30/sec*	Sets the number of times a second to repeat a keystroke while the key is held down.
Keyboard auto-repeat delay	1/4 sec 1/2 sec* 3/4 sec 1 sec	Sets the delay time after a key is held down before it begins to repeat a keystroke.
System memory	Not user selectable	Displays the amount of base (conventional) memory each time the computer boots.
Extended memory	Not user selectable	Displays the amount of extended memory each time the computer boots.

VENTURIS FX and CELEBRIS FX

Advanced

VENTURIS FX and CELEBRIS FX

Menu Fields	Settings	Comments
Plug & Play O/S	Yes* No	Select Yes if using a Plug & Play operating system such as Windows 95. Otherwise, select No .
Reset configuration	Yes No*	Select Yes to clear the system configuration data if you suspect it is corrupted, which sometimes occurs after a power outage. This option also clears the Plug & Play databases. After you input correct settings (or accept the default settings), the computer switches this setting back to No . If you do not need to clear system configuration data, leave the setting at No .
Large disk access mode	DOS* Other	Select DOS if you have MS-DOS installed. Select Other if you have another operating system installed. A large disk drive constitutes one that has more than 1024 cylinders, 16 heads, or 63 tracks per sector.

continued

Menu Fields	Settings	Comments
Integrated Peripherals		
Mouse port	Disabled Enabled*	Enables or disables the mouse port.
Parallel port	Auto Disabled 3BC, IRQ 7 378, IRQ 7* 278, IRQ 5	Enables or disables the onboard port at the specified address. NOTE: Two devices cannot share the same IRQ. Also, choosing Disabled makes the parallel port unusable. Auto is the recommended setting.
Parallel port mode	Compatible mode Bi-directional mode* EPP 1.7 EPP 1.9	Sets the onboard parallel port mode. Standard printer connection. PS/2 compatible mode and able to receive data. Enhanced parallel port mode. Selection based on what EPP version the printer supports. Only choose a mode that your parallel port device (such as a printer) supports. Check the parallel port device documentation for this information. If this information cannot be located, use the default setting.
	ECP-DMA1 mode ECP-DMA3 mode	Extended capabilities port mode.

continued

VENTURIS FX and CELEBRIS FX

Menu Fields	Settings	Comments
Serial port 1	Auto	Enables or disables onboard serial port 1 at the specified address.
	Disabled	
Serial port 2	3F8, IRQ 4*	<p>Select Auto unless interrupts IRQ4 and/or IRQ3 are allocated as a computer resource.</p> <p>Two devices cannot share the same IRQ. Choosing Disable makes serial port 1 unusable. If you select Auto, Setup configures COM1 to address = 3F8h and IRQ = 4 if they are available.</p> <p>Auto is the recommended setting.</p>
	2F8, IRQ 3	
	3E8, IRQ4	
	2E8, IRQ3	
	Auto	
Disabled	<p>Enables or disables onboard serial port 2 at the specified address.</p> <p>Select Auto unless interrupts IRQ4 and/or IRQ3 are allocated as a computer resource.</p> <p>Two devices cannot share the same IRQ. Choosing Disable makes serial port 2 unusable. If you select Auto, Setup configures COM2 to address = 2F8h and IRQ = 3 if they are available.</p> <p>Auto is the recommended setting.</p>	
3F8, IRQ 4		
2F8, IRQ 3*		
3E8, IRQ4		
2E8, IRQ3		

continued

Menu Fields	Settings	Comments
Integrated audio (If available)	Enabled* Disabled	Enables or disables the onboard sound chip; it is SoundBlaster PRO compatible.
Audio DMA	DMA0 DMA1* DMA3 Disabled	Determines the system DMA resource that the sound chip is to use.
Audio IRQ	IRQ5* IRQ7 IRQ10	Determines the system IRQ resource that the sound chip is to use.
Audio 3-D mode	Stereo* Disabled Mono	Stereo selects stereophonic 3-D, sound. Disable prevents 3-D sound. Mono selects monaural (monophonic) 3-D sound.
System speaker volume	Medium* Hi Disabled	Determines the system speaker output volume.
Diskette controller	Enabled* Disabled	Enables or disables the onboard diskette controller.
Exchange diskette drives	Disabled* Enabled	Logically exchanges physical diskette drive designations.
Diskette write protection	Disabled* Enabled	Enables or disables the selected diskette drive's write protect option.
Local bus IDE adapter	Disabled Both* Primary Secondary	Enables or disables the local bus IDE adapter. Both enables both the primary and secondary adapters. Primary enables only the primary adapter while Secondary enables only the secondary adapter.
Advanced Chipset Control		
VGA palette snoop	Enabled Disabled*	Enable informs the VGA and non-VGA compatible cards not to claim VGA palette writes.
Monitor type	Color* Monochrome	Sets color or monochrome as the monitor type connected to the computer.

continued

Menu Fields	Settings	Comments
PCI Device		
Integrated ethernet	Enabled* Disabled	Enables or disables the onboard ethernet, if installed
Default latency timer	Yes* No	Yes means the system uses the minimum latency required by the device. If Yes, do not set the latency timer for Ethernet.
Latency timer	0040* 0048 0050 0058	Sets the minimum guaranteed time slice allocated to the ethernet bus master in PCI bus-clock units.
PCI Device Slot 1		
Default latency timer	Yes* No	Yes means the system uses the minimum latency required by the device. If Yes, do not set the latency timer for PCI device slot 1.
Latency timer	0040* 0048 0050 0058	Sets the minimum guaranteed time slice allocated to the bus master in PCI bus-clock units.
PCI Device Slot 2		
Default latency timer	Yes* No	Yes means the system uses the minimum latency required by the device. If Yes, do not set the latency timer for PCI device slot 2.
Latency timer	0040* 0048 0050 0058	Sets the minimum guaranteed time slice allocated to the bus master in PCI bus-clock units.

Security Options

Menu Fields	Settings	Comments
Supervisor password is	Not user selectable (Disabled)*	Indicates whether or not the supervisor's password is enabled or disabled.
User password is	Not user selectable (Disabled)*	Indicates whether or not the user's password is enabled or disabled.
Set supervisor password	Press [Enter]	<p>Allows a supervisor password to be set. The supervisor password must be set if a user password is to be used.</p> <p>NOTE: Entering Setup with a supervisor password provides full access to all BIOS Setup utility menus.</p>
Set user password	Press [Enter]	<p>Allows a user password to be set. This password can be set only if a supervisor password is entered.</p> <p>When the user has entered his or her name but the supervisor is not logged in, only the following information is accessible:</p> <p>Supervisor password is Enabled. User password is Enabled.</p> <p>Set user password [press enter] to enter a user password.</p> <p>Password on boot Enabled/Disabled (which ever is in effect). This option is not allowed to change.</p> <p>Custom sign on banner Enabled/Disabled (which ever is in effect). This option is not allowed to change.</p>

continued

Menu Fields	Settings	Comments
Password on boot	Enabled Disabled*	Enables or disables the enter password on boot option. If you enable this option, a user or supervisor password must be entered in order for the boot process to complete. If a user or supervisor password is not entered, the operating system cannot be accessed.
Custom sign on banner is	Not user selectable (Disabled)*	Indicates whether the custom sign on banner is enabled or disabled.
Custom sign on banner	Press [Enter]	Press [Enter] to enter a custom sign on banner that displays during POST. For example, the user might enter "Welcome to John's machine." The maximum number of characters is 50.
Diskette access	Supervisor User*	Controls who has access to diskette drives. If <i>Supervisor</i> is selected, access to the diskette drive is limited to the supervisor, who must enter his or her password. If <i>User</i> is selected, the diskette drive can be accessed by entering either the supervisor or the user password. Whatever setting is chosen, it only becomes functional if both a <i>Supervisor Password</i> and a <i>User Password</i> have been set (if you choose <i>User</i> for the setting).

continued

Menu Fields	Settings	Comments
Fixed disk boot sector	Normal* Write protect	Write protects the boot sector on your hard disk drive.
Network server	Enabled Disabled*	This option keeps the computer from being accessed during network operation.
System backup reminder	Disabled* Daily Weekly Monthly	Selecting anything other than <i>Disable</i> displays the system backup reminder every day, on Monday each week, or on the first day of each month, depending on the selection.
Virus check reminder	Disabled* Daily Weekly Monthly	Selecting anything other than <i>Disable</i> displays the virus check reminder every day, on Monday each week, or on the first day of each month, depending on the selection.

Power

VENTURIS FX and CELEBRIS FX

Menu Fields	Settings	Comments
Power management	Enabled* Disabled	Enable this field to use any of the power management options. If this field is enabled and the other fields are disabled, only minimal power reduction is affected.
System standby timer	Disabled 1 min. 5 min.* 10 min. 20 min. 30 min.	<p>After a set period of computer inactivity, the BIOS places the computer in a standby state (medium power savings), that is, the monitor and CPU are set to power management. Any mouse or keyboard activity quickly returns the computer to operation.</p> <p>Alternately, you can choose to disable this option and thereby not use this feature. Power management must be enabled to use this option.</p>
System suspend timer	Disabled 1 hour 1.5 hour* 2 hour 3 hour 6 hour 12 hour	<p>After a set period of computer inactivity, the BIOS places the computer in a suspended state (maximum power savings), that is, the monitor and fan are shut off and the CPU and hard disk are powered down. Any mouse or keyboard activity quickly returns the computer to operation.</p> <p>If you set a timer for the field, you should also set Power Management to Enabled.</p> <p>Alternately, you can choose to disable this option and thereby not use this feature. Power management must be enabled to use this option.</p>

continued

Menu Fields	Settings	Comments
Suspend lock system	Yes No*	<p>When enabled, use a Quick Suspend key sequence to lock both mouse and keyboard and place system in System Suspend. Alternatively, the system goes into Suspend Lock when the system reaches the timeout set in System Suspend Timer.</p> <p>See “Set supervisor password” and “Set user password”, if desired, in the Security Options table.</p> <p>Power management must be enabled to use this option.</p> <p>Select Quick Suspend key sequence; set timeout in System Suspend Timer for system inactivity to trigger Suspend Lock.</p> <p>To wake the system up, enter the Supervisor/User password(s).</p>
Quick suspend	Disabled [Ctrl-Alt-Esc]* [Ctrl-Alt-Scroll Lock] [Ctrl-Alt-F1—F10] [Ctrl-Alt-1—0]	<p>Enabling this option allows you to suspend your computer immediately by pressing the key sequence selected. Unless Suspend Lock System is enabled, keyboard or mouse activity unlocks the system.</p>

VENTURIS FX and CELEBRIS FX

Boot

Menu Fields	Settings	Comments
Boot device sequence	1. Diskette Drive* 2. Hard Drive* 3. CD-ROM Drive*	<p>The numbers refer to the order in which the devices are addressed for the system files needed to boot the system.</p> <p>To change the order, use the Up and Down cursor keys to select the device you want to move. Then use the + and – keys, on the numeric keypad, to move the device to the desired boot order.</p>

Flash Utility

All Venturis FX and Celebris FX computers have BIOS software in a read-only, non-volatile memory (ROM) chip. This BIOS initializes hardware and boots the operating system when the computer is turned on. The BIOS also provides access to other services such as keyboard and disk drives.

The computer comes equipped with flash memory. This means that you can restore the computer's BIOS simply by running the flash utility. If necessary, you can also upgrade the computer's BIOS to future releases by running the flash utility along with any flash BIOS update diskette.

Only use the flash utility to upgrade the computer's BIOS if you are instructed to do so by an authorized Digital support representative. You can download BIOS updates along with the flash utility and instructions on how to flash the computer's BIOS from the Internet or Digital's Bulletin Board Service (BBS).

System Software 3

Introduction

Some Venturis FX computers have both Windows 95 and Windows for Workgroups 3.1 dual installed at the factory. The user or the vendor then select one or the other operating system. Those that were sold later have Windows for Workgroups 3.1, Windows 95, or Windows NT Workstation 4.0 factory installed on the computer.

Celebris FX computers come with Windows 95, Windows NT Workstation 3.51, or Windows NT 4.0 factory installed.

For both Venturis FX and Celebris FX computers, all the necessary drivers are pre-installed at the factory. The operating system, utilities, and device drivers are optimized for computer's configurations and are ready for use.

This chapter describes:

- The software and documentation that came with the computer
- The operating system software kit
- The Software Backup CD-ROM disk and supplied software diskettes
- Configuring video, networking, and additional hardware
- How to use the diagnostic software
- How to restore the factory installed software using the supplied backup CD-ROM disks
- Other device drivers

Factory Installed Software

The following table describes the software installed on the hard disk drive:

Software	Description
Operating system	Dual install of Windows 95 and Windows for Workgroups on some Venturis FX models. Windows for Workgroups, Windows 95, or Windows NT Workstation for later Venturis FX computers. Windows 95 and Windows NT Workstation for Celebris FX models.
On-line documentation.	See "On-Line Documentation."
Application software	See "Applications."
Device drivers	These can include drivers, such as video, mouse, and IDE. Some configurations also include audio, network, and CD-ROM drivers.

On-Line Documentation

An on-line resource library for product information is supplied with the computer. This resource library includes Windows-based help files, electronic reference guides, and Readme files. Electronic reference guides are available in Adobe Portable Document Format (PDF). These documents can be displayed and printed exactly as the original. The Adobe Acrobat Reader is pre-installed on the hard disk drive.

The following table lists the on-line documentation available for the computer and are located in the Digital program group or Digital folder.

On-Line Documentation	Description
<i>System Reference</i>	The on-line System Reference guide describes how to operate, upgrade, and configure the computer. The guide can be viewed and printed using the Adobe Acrobat Reader.
Using Your Computer	Windows-based on-line help file that describes the computer's features.
Digital Service and Support	Windows-based on-line help file that describes service, support, and the computer's warranty.
Readme.txt	Readme.txt files can help set up, operate, and configure the computer. Read this information first.

Other on-line documentation files are available. Many of these relate to specific applications. Check the application program group or the program folder. Also check the applications themselves for the on-line help that is integrated into the applications.

Applications

The factory installed software includes several applications designed to make the computer easier to use. The following table lists the software that is available for the computer. Included in the table is information on where to locate the listed items and a brief description. Note that Windows 95 instructions all begin from Start in the Task Bar.

Applications	Location	Description
Adobe Acrobat Reader	Select from Program Manager the Adobe program group or select Programs and then the Adobe Reader.	Printed electronic documents can be viewed or printed using the Adobe Acrobat Reader software.
ClientWORKS	Select from Program Manager the ClientWORKS program group or select Programs and then ClientWorks.	ClientWORKS is Digital's client management software designed to help network administrators lower the total cost of ownership by automating asset management tasks and managing computers remotely. ClientWORKS is DMI compliant.
DMI (Venturis FX models with Windows for Workgroups installed)	Select from Digital Program Group the DMI program group and then select DMI.	DMI is Digital's client management software designed to help network administrators lower the total cost of ownership by automating asset management tasks and managing computers remotely.
Netscape (Celebris FX models and Venturis FX models with Windows for Workgroups installed)	Select from Program Manager the Netscape program group or select Programs and then Netscape.	Netscape Navigator software is used for accessing information on the World Wide Web.
Microsoft Internet Explorer (all models except Venturis FX with Windows for Workgroups installed)	Select from Program Manager the Microsoft Internet Explorer program group or select Accessories, Internet Tools, and then Internet Explorer. Alternatively, Windows 95 users can select The Internet from the desktop.	Microsoft Internet Explorer is used for accessing information on the World Wide Web (available only in English).

continued

Applications	Location	Description
Easy Network (Windows 95 only)	Select from Program Manager, Digital Program Group and then Digital Easy Network or select Programs, Digital and then Digital Easy Network.	The Easy Network utility can be used to configure the computer with a network.
Power Management (Windows 95 and Windows for Workgroups only)	Select Programs, Digital and then Power Management Utility.	Power Management technology helps reduce the computer's power consumption during computer inactivity. Use the power management software to set the computer's power management features. Alternatively, power management features can be set in BIOS Setup.
PC Care (Windows 95 only)	Select Programs and then PC Care.	PC Care is a diagnostic, computer information, and computer optimization tool. (See "Using Diagnostics.")
"Getting Started" program (some Venturis FX models with Windows 95 and all Venturis FX models with Windows for Workgroups installed)	Select Programs and then "Getting Started."	"Getting Started" provides a place to launch special programs such as Power Management. It also provides an Education section that includes a Windows-based on-line help file called "Using Your Computer." Several tutorials are also included in the Education section.
Audio Applications (only available on some models; Windows 95 required)	Select Programs and then Audio Applications.	Use the Audio Applications software to configure the computer for sound. These utilities provide the convenience of having the controls all in one place.
Video Utilities	Select the Control Panel and then Display	These include utilities such as Matrox MGA or the S3 Refresh, whichever is applicable to the computer. Refresh utilities allows you to set the refresh rate of the display.

Operating System Kit

Venturis FX and Celebris FX computers come with an operating system kit, which matches the operating system installed on the computer's hard disk drive. Use the applicable diskettes, CD-ROM disk, and setup diskettes to restore the computer's operating system:

VENTURIS FX and CELEBRIS FX

Windows for Workgroups (some Venturis FX models)

Windows for Workgroups diskettes, software license, and the manual.

Windows for Workgroups and MS-DOS describes how to use Windows for Workgroups and the MS-DOS operating system.

Windows 95

Windows 95 CD-ROM disk, software license, and the manual.

Introducing Microsoft Windows 95 describes how to use the Windows 95 operating system.

Windows NT Workstation

Windows NT Workstation: CD-ROM disk, setup diskettes, software license. *Microsoft Windows NT Installation Guide* and other documentation.

Microsoft Windows NT Installation Guide describes how to install and use Windows NT, including information about additional networking services.

Software Backup CD and Supplied Diskettes (Windows 95 and Windows NT Workstation)



NOTE: Venturis FX computers with Windows for Workgroups installed are not provided with a backup CD. Instead, master media diskettes must be created using the facility located in the "Getting Started" program.

Included with the computer's accessories are a Software Backup CD-ROM disk and some diskettes. These are described in the following table:

<i>Software Backup CD-ROM disk</i>	This CD-ROM disk contains the applications, utilities, device drivers, and on-line documentation necessary to restore the computer. This disk does not contain the operating system. See CD-INFO.TXT on the CD-ROM disk for non-operating system installation and configuration information.
<i>Windows 95 Startup diskette</i>	Use this diskette to boot the CD-ROM drive to install Windows 95.
<i>Diagnostic diskettes</i>	Use these diskettes to access the hard disk drive if the computer fails to boot. This software can also be used to help troubleshoot the computer should problems occur during normal operation. (See "Using Diagnostics.")
<i>ISA Configuration Utility (ICU) (for non-Plug and Play operating systems, such as Windows NT Workstation only)</i>	Use the ICU to configure ISA non-Plug and Play or legacy expansion boards for operation with a Windows NT Workstation computer. Run the ICU before installing non-Plug and Play ISA expansion boards or legacy boards to determine what computer resources are available. (See "Configuring Additional Hardware.")
<i>SCSI Adaptec Drivers (only for Celebris FX systems with onboard SCSI controllers and Windows NT Workstation installed)</i>	Use the SCSI drivers to configure SCSI devices for Windows NT Workstation.

Configuring Video

Before changing the resolution or resetting a monitor type, check the monitor documentation and make the new selections based on what the monitor can support. Use the Control Panel Display option to configure the video and monitor.

Refer to the Windows 95 User's Guide or the Windows NT Workstation Installation Guide and any related on-line help for configuration information.

Configuring Networking

For those computers with onboard network capabilities, configuration information is available on the Software Backup CD-ROM disk.

Check the root directory on the Software Backup CD-ROM disk for the CD-INFO.TXT file. Read this file first for configuration and installation information.

For Celebris FX computer's with Windows 95 installed, use the Easy Network application to configure the computer with a network and to use the Internet browser.

Configuring Additional Hardware

Adding additional hardware requires configuring the computer's IRQ and DMA settings. For those computer's with the Windows 95 operating system, these settings are automatically assigned and appropriately set.

If necessary, refer to the Microsoft Windows 95 documentation for information on configuring new hardware.

For those computer's with the Windows NT Workstation operating system, these settings must be manually set. Use the ISA Configuration Utility (ICU) diskette to help determine the available resources.

If necessary, access the ICU on-line help for complete instructions.

Using Diagnostics

For those computers with the Windows 95 operating system, the PC Care diagnostic software is included with the factory installed software. Use this software to troubleshoot the computer.

For those computers with the Windows NT Workstation operating system, the factory installed software includes an Administrative Tools group in the Program Manager menu. This program group includes a Windows NT Diagnostics icon for launching the Diagnostic software. Use this software to troubleshoot the computer.

Most Venturis FX and Celebris computers come with two diagnostic diskettes. With these diskettes, users can examine the computer's current configuration, locate faulty components, and troubleshoot problems.

For those that received a backup CD with their computer, there are also disk images on the CD of the diagnostics diskettes. Users can make new diagnostic diskettes from these images by following the directions in the CD-INFO.TXT file, which is also on the backup CD.

Users that have Venturis FX computers with Windows for Workgroups installed and some Venturis FX computers with Windows 95 must make their own diagnostics diskettes as part of the procedure for making backup media.

The diagnostic diskette labeled "For Emergency Use" is also useful should a computer fail to boot. If the computer fails to boot or if the diagnostic software is inaccessible from Windows 95, Windows NT Workstation, or Windows for Workgroups, whichever is relevant, proceed as follows:

1. Insert the diagnostics diskette labeled "For Emergency Use" into the diskette drive and then reboot the computer:
2. Follow the instructions displayed on the monitor screen.

Refer to the Readme.txt file on each of the Diagnostics diskettes for installation instructions and for additional information about the Diagnostics package.

Restoring the Computer's Software

Use the following procedures to restore the computer's operating system, device drivers, and any other utilities or applications.

1. If possible, back up data and any applications.
2. Reformat the hard disk drive, if necessary. Reformat the hard disk drive if it completely failed or if it was replaced with a new one.
3. Install the operating system.

For Windows for Workgroups, follow the instructions on the label of the first operating system diskette that was created and then the instructions displayed on the screen.

Refer to the supplied Windows 95 and Windows NT Workstation documentation for additional information.

4. Install the necessary device drivers.

Refer to the CD-INFO.TXT file on the Software Backup CD-ROM disk for installation and configuration information.



NOTE: Device drivers are subject to change. If necessary, download the latest device drivers using the Internet or through Digital's Bulletin Board service.

Windows for Workgroups users should use File manager and click on the A: drive, which should have the device driver diskette installed. Select either "Setup" or "Install" to install the necessary drivers.

5. Install the supplied applications from the Software Backup CD-ROM disk.

Windows for Workgroups users should install the applications from the backup diskettes. From File manager, choose the A: drive and then select "Setup" or "Install" to install the necessary applications.

Additional Device Drivers

Most of the device drivers are installed at the factory. However, if additional device drivers are required and they were not installed at the factory, use the supplied Software Backup CD-ROM disk to install them. Network, IDE, audio, CD-ROM, and video device drivers are available for the following operating systems:

- Windows 95
- Window NT
- Windows for Workgroups
- OS/2
- SCO UNIX
- Novell NetWare



NOTE: Not all device drivers on the CD-ROM disk are supported.

Check the root directory on the Software Backup CD-ROM disk for the CD-INFO.TXT file. Read this file first for configuration and installation information.

Troubleshooting **4**

Initial Troubleshooting

The following sections provide initial troubleshooting procedures and tables listing specific problems, probable causes, and recommended actions to take if the computer fails after configuring it or after installing optional hardware or software.

Refer to the documentation supplied with the additional options if problems are encountered after installation.

- Keep it simple, only troubleshoot one problem at a time. Also, only make one change at a time. For example, if the IDE hard disk drive fails to boot, do not try all the suggested actions at once. Instead, start with one suggestion such as checking the cables. After securing the cables, try booting the computer. If it does not work, try another suggestion.
- Look for abnormal computer, keyboard, and monitor LED indications. For example, make sure the power on LED lights when you turn on the computer and the drive access indicators light when using either the diskette drive or hard disk drive.
- If there are POST error(s), run the BIOS Setup utility and fix the problem(s) identified by the POST error(s).
- If you installed external devices, make sure all cables are correctly connected to the appropriate devices.
- If you installed devices inside the computer, make sure nothing was bumped or jarred loose, and that all cable connections are securely in place.
- Make sure all device drivers are installed correctly.

- If the computer hangs, soft boot the computer (press the [Ctrl] + [Alt] + [Del] keys). If the computer fails to boot, turn it off, wait until all disk drives completely spin down, and then turn it back on.
- Pay close attention to any error message that appears on the screen.

If the error message is computer related, refer to the “Error Messages” section at the end of this chapter.

If the error message is Windows related, refer to any on-line help and the appropriate Windows documentation supplied with the computer.

- Listen carefully for computer errors in the form of beeps. Record the number of beeps and their pattern then refer to the “Beep Codes” section at the end of this chapter.
- After the computer completes the POST, press [F8] to check each line of the AUTOEXEC.BAT and CONFIG.SYS files (AUTOEXEC.NT and CONFIG.NT files for Windows NT Workstation). Answer Yes to allow each line to execute. If an error message appears, record it and then refer to the “Error Messages” section at the end of this chapter.



NOTE: Windows 95 does not require an AUTOEXEC.BAT and CONFIG.SYS file. If these files are missing, it does not mean that the missing files are the cause of a problem.

- README files come with the computer's factory installed software or as printed material. This README information can help you setup, configure, and operate the computer.
- Run the diagnostics software. Refer to the following section for information on accessing and running the supplied diagnostics program.
- If the computer will not boot into Windows, use the Emergency Repair Disk (Windows NT Workstation) or the startup diskette (Windows 95) to gain access to the computer's hard disk drive. Afterwards, troubleshoot the computer to correct any problems.

Pass/Fail Criteria

As a Final Acceptance Test, the following tests should be run to meet the Pass/Fail criteria:

1. Successful completion of the POST tests.

2. Successful completion of the following AMI module tests (one pass):

System Board	(All Tests)
Memory	(All Tests)
Video	(All Tests)
Hard Disk	(All Tests except: sequential write/read and sequential write/random read)

Floppy Disk	(All Tests)
Keyboard	(All Tests)
COM Ports	(All Tests)
LPT Ports	(All Tests)
Pointer Device	(All Tests)

3. Successful bootstrap of the computer installed operating system.

Operating systems supported:

- Windows for Workgroups
- Windows 95
- Windows NT Workstation

Remove any software that was put on the hard disk drive to enable repair of the computer before shipping.

When completed, clean the outside of the computer with cleaning solution.

Diagnostics

Computers with the Windows 95 operating system installed have PC Care diagnostics software factory installed on the hard disk drive. Use this software to troubleshoot the computer.

Computers with the Window NT Workstation operating system have factory installed software that includes an Administrative Tools group in the Program Manager menu. This program group includes a Windows NT Diagnostics icon for launching the Diagnostic software. Use this software to troubleshoot the computer.

Users can use the diagnostic diskettes to examine the computer's current configuration and locate faulty configurations. Users can also use the software on the diagnostics diskettes to troubleshoot the computer.

To access the diagnostic software:

1. Insert the "For Emergency Use" diskette you received into the diskette drive and then type:

```
A:\AMIDIAG
```

2. If you are unable to boot from the hard disk drive, you can instead boot directly from the "For Emergency Use" diskette.
3. Once the program begins, follow the instructions displayed on the monitor screen.

Refer to the README file on the "For Emergency Use" diskette for additional information.

ClientWORKS and DMI

ClientWORKS is a Desktop Management Interface (DMI) based software application that has been developed by Digital Equipment Corporation.

ClientWORKS for Windows 95 and Windows NT Workstation users can be used to help you, the system manager, or system administrator to identify the computer's current hardware configuration. This feature is useful, for example, if you need to see if you have sufficient memory or a large enough hard disk drive for the applications you want to run. System managers or system administrators can access ClientWORKS data through Simple Network Management Protocol (SNMP) consoles. This feature means the company can protect its current investment in SNMP software and network monitors. Other features include:

- If there is a known computer component that needs to be replaced, under Windows 95 or Windows NT Workstation, a system manager or administrator can access ClientWORKS and get the Field Replaceable Unit (FRU) part number. This part number can then be relayed to the service provider to expedite ordering.
- Serial numbers can easily be identified.
- The amount and type of computer memory installed can easily be identified using ClientWORKS. This is especially useful if you need to know the computer's capabilities prior to loading software.
- A system manager or administrator can use ClientWORKS to remotely access computer configurations that are attached to a network. This feature enables a system manager or administrator to easily maintain an accurate equipment log.

Refer to the supplied ClientWORKS factory installed on-line help or the supplied CD-ROM disk for detailed information on using or installing either program.

Advanced Troubleshooting

Digital has a Customer Replaceable Unit (CRU) process during the warranty period for:

- Digital monitors with screens less than 20 inches
- Mice
- Keyboards
- Speakers
- Other parts as defined by Digital as CRUs

The Digital CRU process provides for overnight shipment of the part directly to the customer site. The Service provider gives the customer instructions for installing the replacement unit and for returning the defective part. Customers are billed for the specified part if they fail to return the part to Digital within ten days of the replacement unit shipment.

In the following troubleshooting tables, “CRU Process” means that when a process is determined to be broken, the Service provider should use the previously-described CRU process.



NOTE: The following troubleshooting suggestions are not in any specific order. They are merely a list of possible problems and solutions.

Computer Troubleshooting

Problem	Possible Cause	Action
No response when the computer is turned on.	Computer is not plugged in.	Turn off the computer, plug it in, and then turn it back on again.
	No power at the wall outlet.	Use another wall outlet.
	Main logic board failure.	Replace the main logic board.
	Main logic board jumpers/switches incorrectly set.	Set all appropriate jumpers/switches (Refer to Chapter 5).
	CPU has failed.	Replace the CPU.
	Power supply has failed.	Replace the power supply.
	Voltage select switch is set incorrectly.	Make sure the setting on the back of the computer matches the country's voltage requirements. Refer to the on-line <i>Quick Setup Guide</i> for more information.

continued

Problem	Possible Cause	Action
Power is on, screen is on, but the computer does not respond.	Keyboard not connected, mouse not connected, or both might be in the wrong port.	Connect the keyboard and/or mouse. If already connected, confirm that each device is in the appropriate port.
Power is on, but there is no screen display.	Brightness and contrast controls are not correctly set.	Adjust the brightness and contrast controls.
	The monitor-off timer has shut the monitor off.	Press [Shift] to reactivate monitor.
	Monitor is off.	Turn on the monitor.
	Monitor cable is incorrectly installed.	Check all monitor connections.
	Incorrect video drivers installed.	Install the correct video drivers.
	Video controller has failed.	For models with S3 video, replace the main logic board. For Celebris FX models with Matrox video card, replace the Matrox video card.
	Matrox video card not seated properly.	For those Celebris FX models with a Matrox video card, reseal the Matrox video card.
Monitor has failed.	To ensure the problem is a monitor failure, if possible, try another monitor. If the new monitor fails to operate, follow the CRU Process to replace the monitor.	

continued

Problem	Possible Cause	Action
Computer operates incorrectly after installing an optional expansion board.	Expansion board installed incorrectly.	Remove the expansion board and reinstall.
	Did not run the ISA Configuration Utility (ICU) to configure a non-Plug and Play expansion board before installation (Windows for Workgroups and Windows NT Workstation only).	Run the ICU to properly configure expansion board and then reboot the computer. Refer to any supplied ICU, Windows for Workgroups, and Windows NT Workstation documentation.
	Expansion board has failed.	Remove expansion board and reboot. If computer boots without errors, replace expansion board.
Computer operates incorrectly after installing optional SIMMs.	SIMMs installed incorrectly.	Remove SIMMs and reinstall.
	SIMMs have failed.	Remove SIMMs and reinstall. Make sure two banks are filled at a time with the correct SIMM size, speed, and type. Refer to the <i>System Reference</i> manual for more information.
		Replace SIMMs.

continued

VENTURIS FX and CELEBRIS FX

Problem	Possible Cause	Action
Computer fails to retain setup information.	Computer battery has failed.	Replace computer battery.
	CMOS power switch (SW1-7) set to "Discharge."	Set CMOS power switch to "Enabled." (Refer to Chapter 5).
Computer displays HIMEM.SYS errors.	Unstable memory at the specified address.	Replace faulty SIMM(s). Run diagnostics.
Computer displays an illegal action message (Windows 95).	Insufficient computer resources for a given operation.	Close all unnecessary applications.
		Close and restart Windows 95.
		Reboot computer.

continued

Problem	Possible Cause	Action
Computer displays a System Error F002 message (Windows NT Workstation)	Faulty hardware.	Run the supplied diagnostic software to identify the faulty hardware. Replace the faulty hardware.
"Couldn't Find NTLDR" (Windows NT Workstation)	NTLDR file is missing from the root directory of the hard disk drive.	<p>Copy the NTLDR file to the hard disk drive's root directory.</p> <p>If using the supplied Windows NT Workstation CD-ROM disk, make the CD-ROM the current drive and then type:</p> <pre>copy\i386\ntldr c:\</pre> <p>at the command line prompt.</p> <p>If using the supplied Windows NT Workstation Setup disks, insert Setup Disk #2 into the diskette drive and then type:</p> <pre>expand ntldr.\$ C:\ntldr</pre> <p>at the command line prompt.</p>
"Error 000001E" (Windows NT Workstation)	The hard disk drive might have corrupted system files.	<p>Run chkdsk on the hard disk drive to correct any corrupted files. Also make sure the hardware is on the supplied <i>Microsoft Windows NT Hardware Compatibility List</i>.</p> <p>If the problem still exists, replace the hard disk drive.</p>

VENTURIS FX and CELEBRIS FX

continued

Problem	Possible Cause	Action
“Error 0x00000069 or 0x00000067” (Windows NT Workstation)	Windows NT Workstation unable to communicate with the computer’s hard disk drive controller.	<p>Using the BIOS Setup utility, slow down the DMA transfer rate of the controller.</p> <p>Make sure both ends of the SCSI bus are terminated.</p> <p>Make sure there are no IRQ or memory address conflicts.</p> <p>Make sure NTDETECT.COM is in the root directory of the boot drive partition.</p> <p>Make sure there are no missing Windows NT Workstation system files.</p> <p>If the problem still exists, replace the main logic board.</p>
“NMI Hardware Error” (Windows NT Workstation)	Faulty hardware.	<p>Make sure all main logic board SIMMs, processor, VRM, video memory, and expansion board connectors are clean and properly seated in their respective sockets.</p> <p>Run the supplied diagnostic software to identify the faulty hardware. Replace any faulty hardware.</p>
Services or subsystems do not start properly (Windows NT Workstation)	Improper configuration, files missing or files not installed.	<p>Use the <i>Services</i> or <i>Devices</i> icons in the <i>Control Panel</i> menu to check for status. Also, check the system log in the <i>Event Viewer</i> for entries relating to the problem.</p> <p>If the problem still exists, reinstall the operating system.</p>

continued

Problem	Possible Cause	Action
<p>Computer does not boot from an IDE hard disk drive.</p>	<p>IDE drive type incorrect.</p>	<p>Run the BIOS Setup utility to identify the correct drive type. See drive type label on drive or consult drive documentation.</p>
	<p>Loose cable connectors. Onboard IDE interface disabled.</p>	<p>Secure all cable connections. Run the BIOS Setup utility and set the Local Bus IDE Adapter to "Enabled."</p>
	<p>Hard disk boot sector is missing.</p>	<p>Repartition and reformat the hard disk drive. Caution: This procedure erases what is currently on the hard disk drive. You might want to try repairing the hard disk drive using a disk drive repair utility. Disk drive repair utilities can be purchased from the local software supplier. If you do repartition and reformat the hard disk drive, proceed as follows for DOS-based operating systems such as Windows 95. Boot from a DOS diskette then enter the following commands: c : cd \dos fdisk Follow the instructions on the monitor screen to create a new hard disk boot sector.</p>
	<p>There might be a boot sector virus.</p>	<p>Run anti-virus software.</p>

VENTURIS FX and CELEBRIS FX

continued

Problem	Possible Cause	Action
Computer does not boot from an IDE hard disk drive.	IDE hard disk is connected to the wrong IDE connector.	Connect the boot disk to the primary IDE connector on the backplane.
	Operating system software is not installed on the IDE hard disk drive.	Install the appropriate operating system.
	IDE hard disk drive is not correctly formatted or the requested partition does not exist.	Format the IDE hard disk drive or partition the IDE hard disk drive using the supplied operating system software.
	There is no software on the requested partition.	Install software on the requested partition.
	IDE hard disk drive jumpers incorrectly set.	Refer to the supplied IDE hard disk drive kit installation instructions.
	IDE hard disk drive has failed.	Replace the IDE hard disk drive.
	IDE hard disk drive ribbon cable has failed.	Replace the ribbon cable.
	IDE controller has failed.	Replace the main logic board.

continued

Problem	Possible Cause	Action
Computer does not recognize an internal or external SCSI device.	SCSI device jumpers incorrectly set.	Refer to the supplied SCSI device kit installation instructions.
	SCSI ID conflicts.	Refer to the supplied SCSI device kit installation instructions on setting SCSI IDs.
	Terminating resistors not removed from the SCSI device.	Remove terminating resistors. Refer to the supplied kit installation instructions.
	SCSI option not enabled in BIOS Setup utility.	Run the BIOS Setup utility and enable SCSI option.
	SCSI cable not terminated.	Terminate each end of the SCSI cable.
	SCSI device not plugged in.	Check power and SCSI cables.
	Loose cable connectors.	Secure all cable connections.

continued

Problem	Possible Cause	Action
<p>Computer does not recognize an internal or external SCSI device.</p>	<p>Hard disk boot sector is missing.</p>	<p>Repartition and reformat the hard disk drive.</p> <p>Caution: This procedure erases what is currently on the hard disk drive.</p> <p>You might want to try repairing the hard disk drive using a disk drive repair utility. Disk drive repair utilities can be purchased from the local software supplier.</p> <p>If you do repartition and reformat the hard disk drive, proceed as follows for DOS-based operating systems such as Windows 95.</p> <p>Boot from a DOS diskette then enter the following commands:</p> <pre>c: cd\dos fdisk</pre> <p>Follow the instructions on the monitor screen to create a new hard disk boot sector.</p>
	<p>There might be a boot sector virus.</p>	<p>Run anti-virus software.</p>
	<p>Loose cable connectors.</p>	<p>Secure all cable connections.</p>
	<p>SCSI adapter has failed.</p>	<p>Replace the SCSI adapter.</p>
	<p>SCSI ribbon cable has failed.</p>	<p>Replace the ribbon cable.</p>
	<p>SCSI device has failed.</p>	<p>Replace the SCSI device.</p>

continued

Problem	Possible Cause	Action
Computer does not boot from an internal SCSI hard disk drive.	Computer not configured for SCSI hard disk drive operation.	Run the BIOS Setup utility and set the IDE controller option to "Disabled." This disables the onboard IDE interface. Note: If you have both IDE and SCSI hard disk drives installed, the computer uses the IDE hard disk drive as the boot device.
	Operating system software is not installed on the SCSI hard disk drive.	Install the appropriate operating system.
	Requested partition does not exist.	Partition the SCSI hard disk drive and then reload the operating software.
	SCSI adapter has failed.	Replace the SCSI adapter.
	SCSI ribbon cable has failed.	Replace the ribbon cable.
	SCSI hard disk drive has failed.	Replace the SCSI hard disk drive.

continued

Problem	Possible Cause	Action
Computer does not boot from a target diskette drive.	Onboard diskette controller disabled.	Run the BIOS Setup utility and set the diskette controller option to "Enabled."
	Diskette drive not enabled.	Run the BIOS Setup utility to enable the diskette drive
	BIOS Setup diskette write option enabled.	Enter the user password. If a supervisor password is required, see the system supervisor or system manager.
	Incorrect diskette drive type.	Run the BIOS Setup utility and select the correct drive type.
	Diskette boot option disabled.	Run the BIOS Setup utility and set the proper boot sequence.
	Diskette might not be bootable.	Use a bootable diskette.
	Diskette does not contain start-up files.	Insert a diskette with the correct start-up files.
	Diskette drive is empty.	Insert a diskette that contains an operating system.
	Diskette is worn or damaged.	Try another diskette.
	Loose cable connectors.	Secure all cable connections.
	Diskette access requires a supervisor password.	See the supervisor or system manager.
	Diskette access requires a user password.	Enter the user password.
	Diskette controller failed.	Replace main logic board.
	Diskette drive failed.	Replace diskette drive.

continued

Problem	Possible Cause	Action
No response to keyboard commands.	Keyboard is password protected.	Enter the keyboard password.
	Keyboard is not connected.	Power down the computer and connect the keyboard.
	Keyboard is connected to the mouse port.	Power down the computer and connect the keyboard to the keyboard port.
	Computer operation halted.	Reboot computer.
	Keyboard has failed.	To ensure the problem is a keyboard failure, if possible, try another keyboard. If the new keyboard fails to operate, follow the CRU Process to replace the keyboard.
	Keyboard controller has failed.	Replace the main logic board.

continued

Problem	Possible Cause	Action
Keyboard keys type incorrectly.	Incorrect language selected.	Select the correct language.
	Keyboard has failed.	To ensure the problem is a keyboard failure, if possible, try another keyboard. If the new keyboard fails to operate, follow the CRU Process to replace the keyboard.
No response to mouse activity.	Mouse is not connected.	Power down the computer and connect the mouse.
	Mouse is connected to the keyboard port.	Power down the computer and connect the mouse to the mouse port.
	Computer operation halted.	Reboot computer.
	Mouse driver not installed.	Install the appropriate mouse driver.
	Onboard mouse controller disabled.	Run the BIOS Setup utility and set the mouse port option to "Enabled."
	Mouse has failed.	To ensure the problem is a mouse failure, if possible, try another mouse. If the new mouse fails to operate, follow the CRU Process to replace the mouse.
	Mouse controller has failed.	Replace the main logic board.
Mouse sticks.	Dirty mouse ball.	Remove mouse ball and clean it.

continued

Disk Drive Troubleshooting

Problem	Possible Cause	Action
IDE/SCSI hard disk drive cannot read or write information.	Incorrect disk drive jumper settings.	Refer to the supplied kit installation instructions.
	Loose or incorrectly installed cables.	Make sure all cables are correctly installed.
	IDE/SCSI hard disk drive is not correctly formatted or partitioned.	Format and partition as required using the supplied operating system.
	IDE drive type incorrect.	Run the BIOS Setup utility to identify the correct drive type.
	Onboard IDE interface disabled.	Run the BIOS Setup utility and set the Local Bus IDE Adapter to "Both."
	IDE/SCSI hard disk drive has failed.	Replace the hard disk drive.
	IDE/SCSI controller has failed.	Replace the main logic board (IDE) or the SCSI controller.
	IDE/SCSI ribbon cable has failed.	Replace the ribbon cable.

continued

Problem	Possible Cause	Action
Target diskette drive cannot read or write information.	Diskette is not formatted.	Format the diskette.
	Diskette is worn or damaged.	Try another diskette.
	Diskette is write-protected.	Slide the write-protect switch so the hole is not visible (3½-inch diskette) or uncover the write-protect notch (5¼-inch diskette).
	Diskette drive is empty.	Insert a diskette.
	Onboard diskette controller disabled.	Run the BIOS Setup utility and set the diskette controller option to "Enabled".
	Diskette write protection is enabled.	Run the BIOS Setup utility and set the diskette write protection to "Disabled."
	Loose cable connectors.	Secure all cable connections.
	Diskette drive has failed.	Replace the diskette drive.
	Diskette drive controller has failed.	Replace the main logic board.
	Diskette drive ribbon cable has failed.	Replace the ribbon cable.
Target diskette does not format diskettes.	Diskette access requires supervisor password.	Reboot computer and enter the supervisor password. Afterwards, run BIOS Setup utility and set "Diskette Access" option to "User."
	Diskette write protection is enabled.	Run the BIOS Setup utility and set the diskette write protection to "Disabled."
	Diskette drive has failed.	Replace the diskette drive.

Monitor Troubleshooting

Problem	Possible Cause	Action
Monitor power indicator is not on.	Monitor is turned off.	Turn on the monitor.
	Power cord is not connected.	Connect the power cord to the computer.
	No power at wall outlet.	Use another outlet.
	The monitor-off timer shut off the monitor.	Press [Shift] to reactivate monitor.
	Monitor has failed.	To ensure the problem is a monitor failure, if possible, try another monitor. If the new monitor fails to operate, follow the CRU Process to replace the monitor.
	Video controller has failed.	Replace the main logic board (Matrox graphics) or backplane (S3 graphics).
No screen display.	Power indicator is defective.	Follow the CRU Process to replace the monitor.
	Configuration error.	Run the BIOS Setup utility to configure the computer for correct video operation.
	Monitor brightness and contrast controls are incorrectly set.	Adjust the monitor brightness and contrast controls.
	The monitor-off timer shut off the monitor.	Press [Shift] to reactivate monitor.

continued

Problem	Possible Cause	Action
No monitor display while loading Windows video drivers.	Wrong Windows driver loaded.	Load the correct video driver.
Distorted, rolling, or flickering screen display, or wrong/uneven color.	Monitor incorrectly adjusted.	Adjust accordingly.
	Monitor signal cable incorrectly installed.	Straighten any bent connector pins and then reconnect.
Color monitor displaying monochrome.	Computer was turned on before the monitor was turned on.	Turn off the computer, turn on the monitor, then turn the computer back on.
	Monitor type incorrectly set.	Run the BIOS Setup utility and set the monitor type to "Color."
Monitor fails to switch to high-resolution mode.	Appropriate high-resolution video drivers are not installed or incorrectly installed.	Correctly install all appropriate high-resolution video drivers. Refer to the documentation supplied with the monitor.
Monitor display disappears.	Screen display sized incorrectly.	Correctly size screen display.

Audio Troubleshooting

Problem	Possible Cause	Action
Audio does not work.	Sound, MIDI, mixer drivers not installed.	Check the error messages for the necessary drivers. In Windows Control Panel, select "Drivers", then "Add" and install the necessary driver(s).
	Address contention. Two or more devices might be trying to access the same address.	Check IRQ, I/O address, and DMA settings in Windows 95, Windows NT Workstation, or BIOS Setup. Change settings as required.
	Cables loose or not properly connected.	Make sure speaker and microphone plugs are in correct jacks. Reconnect cables.
	Onboard audio controller disabled.	Run the BIOS Setup utility and set the Integrated Audio to "Enabled."
	Bad audio chip or sound card.	Replace the backplane or sound card.
	Main logic board has failed.	Replace the main logic board.

continued

Problem	Possible Cause	Action
External speakers do not work.	Speakers not connected or improperly connected.	Properly connect the speakers. Refer to the <i>System Reference</i> manual for more information.
	Speaker batteries or ac adapter have failed.	Replace speaker batteries or ac adapter. Refer to the documentation that came with the speakers.
	Speakers have failed.	To ensure the problem is an external speaker failure, if possible, try another set of speakers. If the new speakers fail to operate, follow the CRU Process to replace the external speakers.
Microphone does not work.	Microphone not connected or improperly connected.	Properly connect the microphone. Refer to the <i>System Reference</i> manual for more information.
	Microphone has failed.	To ensure the problem is a microphone failure, if possible, try another microphone. If the new microphone fails to operate, follow the CRU Process to replace the microphone.
Headphone set do not work.	Headphone set not connected or improperly connected.	Properly connect the headphones. Refer to the <i>System Reference</i> manual for more information.
	Headphone set has failed.	To ensure the problem is a headphone set failure, if possible, try another headphone set. If the new headphone set fails to operate, follow the CRU Process to replace the headphone set.

Network Interface Troubleshooting

Problem	Possible Cause	Action
Power is on, LAN address is installed on computer; system hangs.	Incorrect software installed or software installed incorrectly.	Contact system administrator or network coordinator.
Network doesn't start.	Network cable not connected or is loose.	Connect cable. Also, make sure no more than one ethernet cable is connected at one time.
	Conflict exists with another device adapter; incorrect IRQ setting.	Check BIOS setup, Windows 95, or Windows NT Workstation settings.
	Network cable has failed.	Contact the system administrator or network coordinator.
	Onboard network controller disabled.	Run the BIOS Setup utility and set Integrated Ethernet to "Enabled."
	Onboard network controller has failed.	Replace the backplane.

CD-ROM Troubleshooting

Problem	Possible Cause	Action
Cannot access the CD-ROM drive. Error message reading drive x.	Device drivers not installed.	Install correct device drivers.
	No disk in the CD-ROM drive.	Insert a disk.
	CD-ROM drive tray is open.	Close the tray.
	Onboard IDE interface disabled (if IDE CD-ROM)	Run the BIOS Setup utility and set the Local Bus IDE Adapter to "Enabled."
	CD-ROM has failed.	Replace the CD-ROM.
	Cables have failed.	Replace defective cables.
Power is on but CD-ROM drive indicator shows no activity.	No CD-ROM disk or CD-ROM drive tray is open.	Insert a disk and close the tray.
	Check cable connections.	Make sure cables are correctly connected.
	CD-ROM has failed.	Replace the CD-ROM.
	Cables have failed.	Replace defective cables.
CD-ROM disk is spinning but CD-ROM drive is idle.	Application software not running.	Run application software.

Error Messages

This section lists computer messages you might see or hear when you turn on power. The computer messages are grouped as follows:

- POST and boot computer messages
- POST execution messages
- Beep codes

POST Messages

The POST displays messages to alert you to errors in hardware, software, and firmware or to provide operating information about the computer.

Each time the POST displays a message on the screen, the computer's speaker beeps twice. If an error occurs before the monitor is initialized, specific beep codes sound to alert you to a problem. The following table lists a general grouping of computer messages. In addition, each message is accompanied by text describing the message and in most cases, a recommended solution to the problem.



NOTE: Italics indicate variable parts of a message such as memory addresses, hexadecimal values, and so on. These messages can differ at each occurrence.

POST and Boot Messages

VENTURIS FX and CELEBRIS FX

Message	Description/Solution
Asynchronous Synchronous Burst Synchronous Pipeline Burst Passed	Where <i>nnnn</i> is the amount of computer cache (in kilobytes) that tested successfully.
Diskette drive A error	Run the BIOS Setup utility. Check all connections. If the problem persists, replace the diskette drive.
Diskette drive B error	
Entering SETUP	BIOS Setup utility runs.
Extended RAM Failed at offset: <i>nnnn</i>	Extended memory failed or configured incorrectly. Make sure SIMMs are installed correctly (Refer to <i>System Reference</i> manual). If the problem persists, replace any faulty SIMMs. Run the BIOS Setup utility and restore all settings to original values.
Extended RAM Passed	Where <i>nnnn</i> is the amount of extended memory (in kilobytes) that tested successfully.
Failing Bits: <i>nnnn</i>	<i>nnnn</i> is a map of the bits at the RAM address which failed the memory test. Run the BIOS Setup utility and restore all to original values. If the problem persists, replace any faulty SIMMs.
Fixed Disk 0 Failure	Run the BIOS Setup utility. Check all connections. If the problem persists, replace the hard disk drive.
Fixed Disk 1 Failure	Fixed disk controller failure

continued

Message	Description/Solution
Incorrect Drive A type - run SETUP	Diskette drive A and/or B not correctly identified in the BIOS Setup utility.
Incorrect Drive B type - run SETUP	Run the BIOS Setup utility and properly identify diskette drive A and/or B.
Invalid NVRAM media type	NVRAM access failed. Run the BIOS Setup utility and restore all settings to original values. If the problem persists, replace the main logic board.
Keyboard controller error	Check the keyboard connection. If the connection is secure, the keyboard or keyboard controller might have failed. If the problem persists, replace the main logic board or keyboard.
Keyboard error	
Keyboard locked - Unlock key switch	
Monitor type does not match CMOS - Run SETUP	Run the BIOS Setup utility and set the correct monitor type.
Operating system not found	The operating system cannot be found on drive A or drive C. Run the BIOS Setup utility and correctly identify drive A or drive C. Correctly install the operating system. Refer to the supplied operating system documentation.
Press <F1> to resume, <F2> to Setup	This message appears after any recoverable error message. Press [F1] to reboot or [F2] to enter the BIOS Setup utility to make any necessary changes.
Real time clock error	Battery failed BIOS test. Replace battery and then run the BIOS Setup utility to restore previous configuration information.

continued

Message	Description/Solution
Shadow RAM Failed at offset: <i>nnnn</i>	Shadow RAM failed. Run the BIOS Setup utility and disable failed shadow memory region.
<i>nnnn</i> Shadow RAM passed	Where <i>nnnn</i> is the amount of shadow RAM (in kilobytes) that tested successfully.
RTC is dead - Replace and run SETUP	Replace the battery and then run the BIOS Setup utility to restore previous configuration information.
System BIOS shadowed	This indicates that the computer's BIOS was successfully copied to shadow RAM.
System cache error - Cache disabled	RAM cache failed. Run the BIOS Setup utility and restore all settings to original values. If the problem persists, replace faulty processor.
System CMOS checksum bad - run SETUP	Correct the address conflict using the BIOS Setup utility. If the problem persists, replace the main logic board.
System RAM failed at offset: <i>nnnn</i>	System RAM failed. Run the BIOS Setup utility and restore all settings to original values. If the problem persists, replace any faulty SIMMs.
<i>nnnn</i> System RAM passed	Where <i>nnnn</i> is the amount of system RAM (in kilobytes) that tested successfully.
System timer error	The computer's timer test failed. Run the BIOS Setup utility and restore all settings to original values. If the problem persists, replace the main logic board.
UMB upper limit segment address: <i>nnnn</i>	Displays the address of the upper limit of UMB. This indicates the released segments of the BIOS that can be reclaimed by a virtual memory manager.
Video BIOS shadowed	This indicates that the computer's video BIOS was successfully copied to shadow RAM.

POST Execution Messages

The following messages appear at the bottom of the screen during POST execution.

Message	Description
230	Unexpected interrupts test
220	Shadow ROMs
210	Test RAM between 512K and 640K
200	Extended memory test
190	Set cache registers
180	Cache configuration
170	Real-time clock test
160	Keyboard test
150	Initial hardware interrupt
140	Co-processor test
130	Serial ports test
120	Parallel ports test
110	Initiate onboard SIO
100	Mouse test
95	CD-ROM initialize
90	Testing diskette drives
80	Testing hard disk drives
30	Setup power management
20	Enable IRQs
10	Setting time of day

Beep Codes

When POST finds an error and cannot display a message, the computer's speaker emits a series of beeps to indicate the error and places a value in I/O port 80h. During POST, if the video configuration fails or if an external ROM module fails a checksum test, then the computer beeps three times (one long beep, and two short beeps).

The following table lists other fatal errors and their associated beep codes. Each code represents the number of short beeps that are grouped together. Fatal errors (errors that lock up the computer) are generally the result of a failed main logic board or some other add-on component (SIMM, BIOS, computer battery, etc.).

Beep Code	Error
1	One short beep before boot
1-2	Search for option ROMs
1-2-2-3	BIOS ROM checksum
1-3-1-1	Test DRAM refresh
1-3-1-3	Test keyboard controller
1-3-4-1	Test 512K base address lines
1-3-4-3	Test 512K base memory
1-4-1-1	Test memory bus
2-1-2-3	Check ROM copyright notice
2-2-3-1	Test for unexpected interrupts

FRU Replacement **5**

Venturis FX and Celebris FX Low Profile FRU List

VENTURIS FX and CELEBRIS FX

Figure Legend	Orderable Spare Part	Exchangeable Spare Part	Description
1	54-24544-01	54-24588-01	MLB, Venturis FXe (bidbox)
	54-24544-02	54-24588-02	MLB, Venturis FX and Celebris FX (standard)
	54-24544-03	54-24588-03	MLB, Venturis FSsm (multimedia)
	54-24544-06	54-24588-04	MLB, Venturis FX and Celebris FX Japan (standard)
	54-24544-08	54-24588-05	MLB, Venturis FXsm Japan (multimedia)
	54-24588-06		MLB, Celebris FX Matrox option (standard)
2	54-24506-01		MOD, Slimline Riser Card
	54-24508-01		MOD, Slimline Riser Card with Network (Celebris FX only)
3	54-24074-02	20-47081-01 20-47082-01	MOD, 256K Pipelined Burst SRAM
	54-24488-02		MOD, 512K Pipelined Burst SRAM
4	54-21225-JA	54-23623-HA	1MX32 60 ns EDO DRAM Module (4MB EDO)
	54-21246-JA	54-23623-JA	2MX32 60 ns EDO DRAM Module (8MB EDO)
	54-23170-HA		4MX32 60 ns EDO DRAM Module (16MB EDO)
	54-21277-KA		8MX32 60 ns EDO DRAM Module (32MB EDO)

continued

VENTURIS FX and CELEBRIS FX

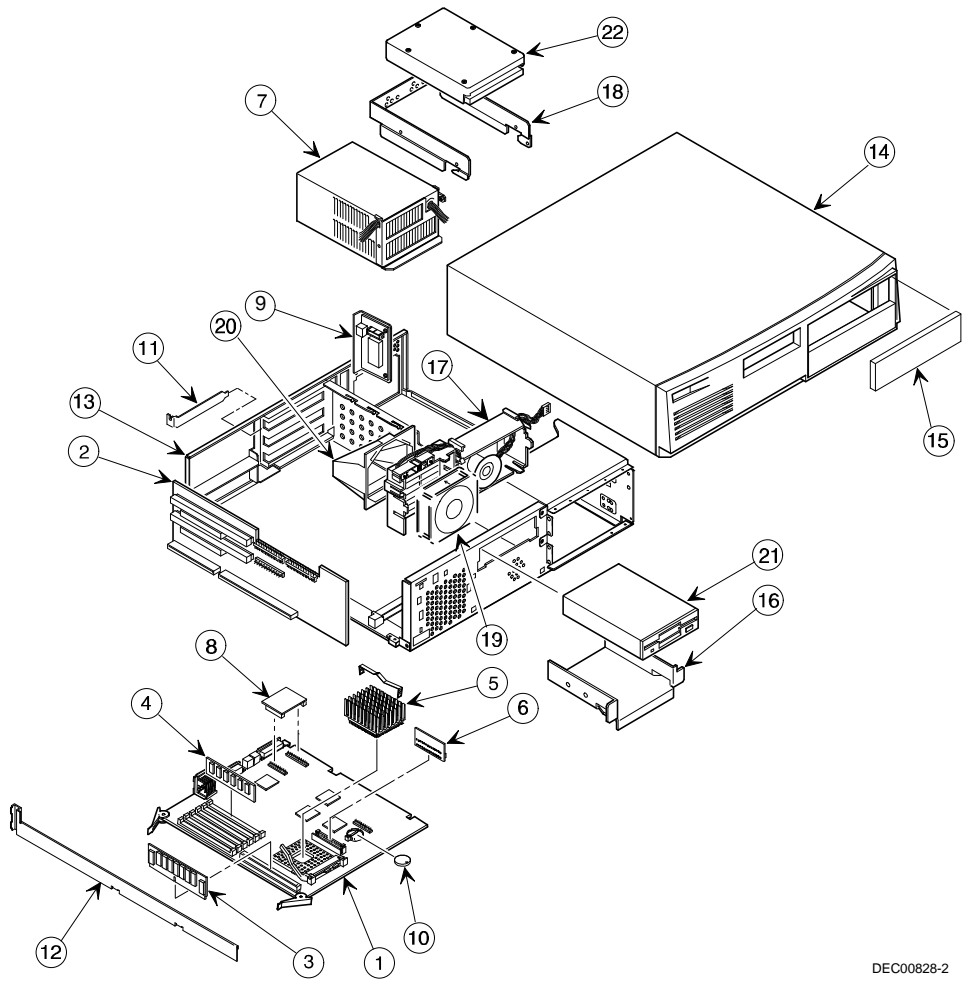

DEC00828-2

Figure 5-1. Venturis FX and Celebris FX Low Profile

Figure Legend	Orderable Spare Part	Exchangeable Spare Part	Description
5	90-08268-00		Compound, Thermal Joint
	12-41706-05		Heat Sink 54C
	12-46311-01		Clamp for Intel 586 CPU
	21-43669-03		Microprocessor, 75 MHz
	21-43652-04		Microprocessor, 100 MHz
	21-43768-02		Microprocessor, 120 MHz
	21-43828-03		P54CS-133 Processor, STD, B1 Stepping
	21-43975-01		P54CS 166 MHz, Processor VRE C0 Stepping
	21-47163-02		P54CS Processor, 200 MHz, 296 Pin
6	12-46680-02	54-24040-01 12-46680-01	Conn, Shorting Block (133 MHz CPU and below)
	54-24516-01		Module, Voltage Regulator (166 and 200 MHz CPUs)
7	30-46902-01		Power Supply, Switching 100W, +3.3V
8	54-24514-01		MPEG Board
	54-24538-02		Rear Panel Bracket, Audio (included with MPEG board)
9	54-24538-01		Rear Panel Card, Network (Celebris FX only)
10	12-41474-05		Battery, 3 VDC Lithium, CR2032

VENTURIS FX and CELEBRIS FX

Enclosure

VENTURIS FX and CELEBRIS FX

Figure Legend	Orderable Spare Part	Exchangeable Spare Part	Description
11	74-50747-01		Option Filler Plate, PCI/ISA Slots
12	74-50733-01		Bracket, Base Side
13	70-32677-01		Enclosure, Low Profile
14	70-32675-01 70-32893-01		Top Cover, with Bezel and Filler Panel Bezel, with Filler Panels
15	70-50742-01		Bezel Blank, 5.25" Drive
16	74-50762-01		Bracket, 3.5" FDD
17	70-32692-01		Assy, Control Panel
18	74-50734-01		Bracket, 3.5" HDD
19	12-45246-03		Fan, Tube Axial, With Brushless DC MO
20	74-50798-01		Air Duct
N/I ⁽¹⁾	74-50912-01 74-50913-01		3.5" FDD Shield, Blank Bezel, 3.5" FDD Blank
N/I ⁽¹⁾	90-17008-02		Screw, Captive 6-32
N/I ⁽¹⁾	74-50804-01		Rubber Feet
N/I ⁽¹⁾	74-50911-01		Bracket, I/O Expansion
N/I ⁽¹⁾	17-04372-01		Cable, Control Panel
N/I ⁽¹⁾	74-50737-01		Card Guide, MLB
N/I ⁽¹⁾	74-50958-01		Bracket, Hasp
N/I ⁽¹⁾	74-50752-01		Bracket, EMI Shield, 5.25"
N/I ⁽¹⁾	74-51734-01		Protective washer for riser card
N/I ⁽¹⁾	74-50913-01		3.5 FDD bezel
N/I ⁽¹⁾	74-50912-01		3.5 FDD shield
N/I ⁽¹⁾	90-11334-01		Screw, 6-32 Machine

⁽¹⁾ N/I = Not Illustrated

Storage Devices

Figure Legend	Orderable Spare Part	Exchangeable Spare Part	Description
21	PCXRJ-AD		1.44 MB Floppy Disk Drive Frost White Flat Bezel
	PCXRJ-AA		Floppy Disk Drive, 3.5", 3 Mode
22	PCXRA-AB	RE-45B-E	850 MB IDE Disk Drive, 4500RPM, Quantum Trailblazer
	PCXRA-AE		1.6 GB IDE Disk Drive, 5200RPM, Western Digital (Venturis FX only)
	PCXRA-AI		Hard Drive 640 MB FB640AT IDE 5400RPM Quantum
	PCXRE-AB		1280 MB Narrow SCSI Drive Quantum
	PCXRA-AM		2.5 GB HDD
	PCXRA-AJ ⁽²⁾		Disk Drive IDE 1200 MB 5200 RPM 3
	PCXRE-AA		Hard Drive 1 GB SCSI Narrow Quantum
	PCXRA-AN ⁽²⁾		2.1 GB IDE Disk Drive, Quantum TM2160A
	RZ28C-E		2.0 GB SCSI HDD
	PCXRA-DB		1.2 GB IDE Disk Drive, Quantum
	PCXRA-AL		1.6 GB IDE Disk Drive, Quantum
	PCXRA-AM		2.5 GB IDE Disk Drive, Quantum
N/I ⁽¹⁾	90-08020-01		Screw, Machine 6-32 Pan .187 x XRCS (HDD)

⁽¹⁾ N/I = Not Illustrated

⁽²⁾ Qualified only for Celebris FX computers

VENTURIS FX and CELEBRIS FX

continued

Figure Legend	Orderable Spare Part	Exchangeable Spare Part	Description
N/I ⁽¹⁾	90-40217-01		Screw, Machine M3 Pan 5 mm x XRCS CSZ (FDD and CD-ROM)
N/I ⁽¹⁾	TZK11-AA ⁽²⁾		2/4 GB QIC SCSI Internal
	TLZ07 ⁽²⁾		4.0/8.0 GB RDAT Drive
	PCXRN-AA ⁽²⁾		6x IDE CD-ROM Drive
	PCXRN-AF		8x IDE CD-ROM Drive
	30-45370-01		5.25" SCSI 4x CD-ROM Drive
	PCXAT-DA ⁽²⁾		Conner External SCSI Tape Drive
N/I ⁽¹⁾	90-10961-01		Screw, Machine M3 Pan 4 mm XRCS SSP (CD-ROM)
N/I ⁽¹⁾	74-48510-01		Exchange Bracket 5.25" to 3.5"
N/I ⁽¹⁾	79-49365-01		Holder, Drive Rail

⁽¹⁾ N/I = Not Illustrated

⁽²⁾ Not qualified for Celebris FX computers

Cables

Orderable Spare Part	Exchangeable Spare Part	Description
17-03460-13		Cable, Floppy
17-03461-10		IDE, Flat Cable, HDD
17-03461-12		IDE, Flat Cable, CD
17-04375-01		Cable, Network
17-04371-01		Wire Assembly, Video

Nameplates

Orderable Spare Part	Exchangeable Spare Part	Description
74-48816-01		Digital Medallion
74-51175-02		Nameplate, Venturis FX
74-51175-03		Nameplate, Celebris FX
74-51176-02		Speed Button, 575
74-51176-04		Speed Button, 5100
74-51176-06		Speed Button, 5120
74-51176-08		Speed Button, 5133
74-51176-12		Speed Button, 5166
74-51176-30		Speed Button, 5200
74-51176-26		Speed Button, 575e, Venturis FX (bid box)
74-51176-27		Speed Button, 5100e, Venturis FX (bid box)

VENTURIS FX and CELEBRIS FX

Miscellaneous

Orderable Spare Part	Exchangeable Spare Part	Description
21-44145-38	21-40847-38 21-44141-38	1 MB Video DRAM EDO 50 ns 256KX16X2 Upgrade (not applicable for Venturis FXe models or Celebris FX models with Matrox option)
PCXJF-AA		Headset Labtec C-10
PCXJB-AD		Microphone Goldtron
PCXLN-AA		2-button Mouse White, Retail, Bulk Packaged
30-46117-02		3-button Mouse, White
PCXJA-AG		Midiland Speaker 7W w/ PWR Adapter
PCXJA-AF		Midiland Speaker 7W w/o PWR Adapter
PCXJA-AE		Midiland Speaker 10W w/ PWR Adapter
PCXJA-AD		Midiland Speaker 10W w/o PWR Adapter
PCXZA-AA		Adaptec 1540CP PnP
PCXZA-AB		Adaptec 1540CF ISA (Japan)
PCXJD-AB		Creative Labs PnP Sound Card
12-41670-01		Terminator, SCSI, 50P IDC, Single End
17-03895-03		Cable Assy, Non-Mold, Flat, RCPT (SCSI Internal)
30-42291-01		28.8 K Data/28.8 Fax Modem
30-42551-01		Adaptec 2940 PCI
30-44396-03		Ensonic Wave Card
30-47658-01		Power Adapter 12v DC 220V AC for Midiland Speakers
30-47657-01		Power Adapter 12v DC 240V AC for Midiland Speakers
30-47659-01		Power Adapter 12v DC 110/120V AC for Midiland Speakers
74-49836-01		Bumper for MLB
54-24030-01		DE450-AA
54-24187-01		DE500-XA
PCXAG-AQ		Matrox Millenium Video Card (576-05 version)
PCCAM-CA		2 MB Matrox Video RAM Module
PCCAM-CB		6 MB Matrox Video RAM Module

VENTURIS FX and CELEBRIS FX

Venturis FX Short Tower FRU List

Figure Legend	Orderable Spare Part	Exchangeable Spare Part	Description
1	54-24544-02	54-24588-02	MLB, Venturis FX and Celebris FX (standard)
	54-24544-03	54-24588-03	MLB, Venturis FSsm (multimedia)
	54-24544-06	54-24588-04	MLB, Venturis FX and Celebris FX Japan (standard)
	54-24544-08	54-24588-05	MLB, Venturis FXsm Japan (multimedia)
2	54-24546-01		Riser Card w/o Audio
	54-24546-02		Riser Card with Audio
3	54-24074-02	20-47081-01	MOD, 256K Pipelined Burst SRAM
		20-47082-01	
4	54-24488-02		MOD, 512K Pipelined Burst SRAM
	54-21225-JA	54-23623-HA	1MX32 60 ns EDO DRAM Module (4MB EDO)
	54-21246-JA	54-23623-JA	2MX32 60 ns EDO DRAM Module (8MB EDO)
	54-23170-HA		4MX32 60 ns EDO DRAM Module (16MB EDO)
	54-21277-KA		8MX32 60 ns EDO DRAM Module (32MB EDO)
5	90-08268-00		Compound, Thermal Joint
	12-41706-05		Heat Sink 54C
	12-46311-01		Clamp for Intel 586 CPU
	21-43669-03		Microprocessor, 75 MHz
	21-43652-04		Microprocessor, 100 MHz
	21-43768-02		Microprocessor, 120 MHz
	21-43828-03		P54CS-133 Processor, STD, B1 Stepping
	21-43975-01		P54CS 166 MHz, Processor VRE C0 Stepping
	21-47163-02		P54CS Processor, 200 MHz, 296 Pin

continued

VENTURIS FX and CELEBRIS FX

VENTURIS FX and CELEBRIS FX

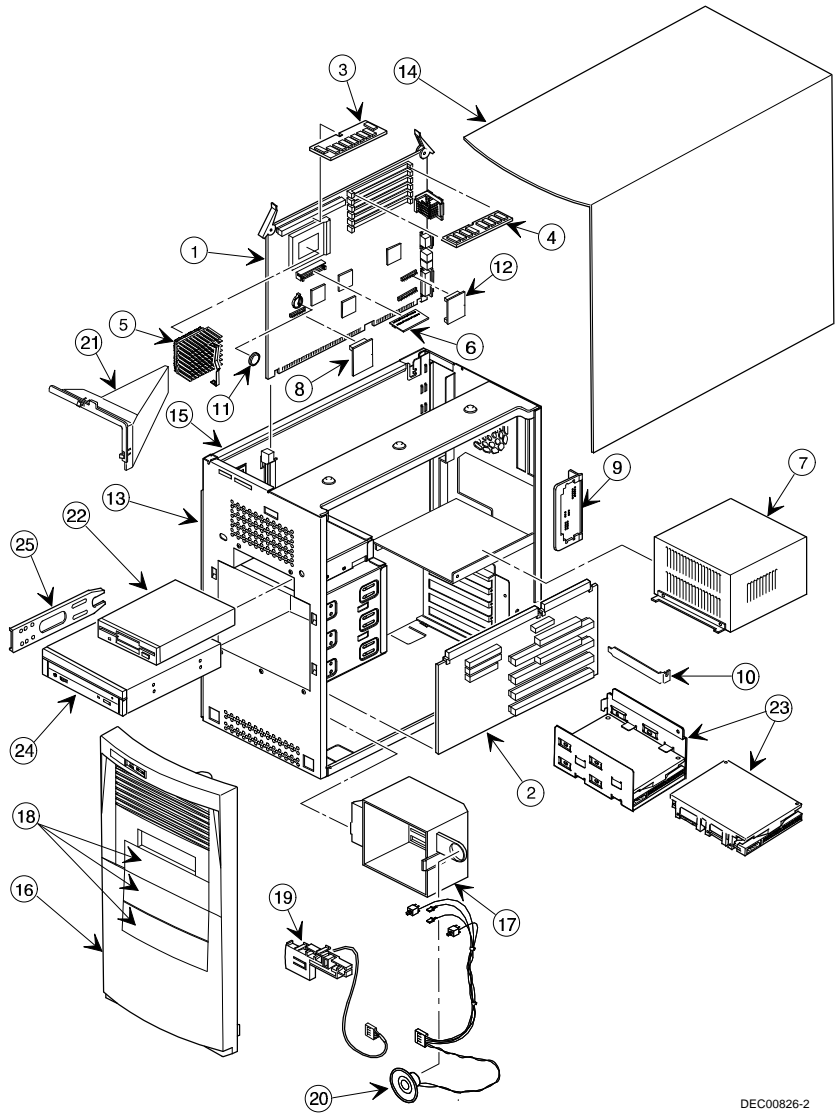

DEC00826-2

Figure 5-2. Venturis FX Short Tower

Figure Legend	Orderable Spare Part	Exchangeable Spare Part	Description
6	12-46680-02	54-24040-01 12-46680-01	Conn, Shorting Block (133 MHz CPU and below)
	54-24516-01		Module, Voltage Regulator (166 and 200 MHz CPU)
7	30-46882-01		Power Supply, Switching 200W 3.3V W
8	54-24512-01		Wave Table
9	54-24538-02		Rear Panel Bracket, Audio
10	74-50747-01		Option filler plate
11	12-41474-05		Battery, 3 VDC Lithium, CR2032
12	54-24514-01		MPEG Board
N/I ⁽¹⁾	54-24526-02		Mod, Front Panel Audio Board and Wire Harness

⁽¹⁾ N/I = Not Illustrated

Enclosure

VENTURIS FX and CELEBRIS FX

Figure Legend	Orderable Spare Part	Exchangeable Spare Part	Description
13	70-32678-01		Enclosure, Short Tower
14	70-32803-01		Cover, L-Shape
15	74-50757-01		Side Panel Left
16	70-32680-01		Bezel, with Filler Panels
17	74-50755-01		Guide, Option Cards
18	74-50860-01		Bezel Blank, 5.25" Drive, Top
	74-50861-01		Bezel Blank, 5.25" Drive, Middle
	74-50862-01		Bezel Blank, 5.25" Drive, Bottom
19	74-50863-01		Control Panel
20	17-04372-02		Speaker/LED, Switch Wire Harness Assembly (for Short Tower)
21	74-51237-01		Air Duct
N/I ⁽¹⁾	74-50752-01		Bracket, EMI Shield, 5.25"
N/I ⁽¹⁾	90-17008-02		Screw, Captive 6-32
N/I ⁽¹⁾	74-51171-01		3.5" FDD Shield, Blank
N/I ⁽¹⁾	74-50914-01		Bezel, 3.5" FDD Blank
N/I ⁽¹⁾	74-51239-01		Filler, Vent Cover, Bottom Front
N/I ⁽¹⁾	74-51361-01		Vent Cover, Top Front
N/I ⁽¹⁾	74-51362-01		Vent Cover, Top Rear
N/I ⁽¹⁾	74-50804-01		Rubber Feet
N/I ⁽¹⁾	74-50911-01		Bracket, I/O Expansion

⁽¹⁾ N/I = Not Illustrated

Storage Devices

Figure Legend	Orderable Spare Part	Exchangeable Spare Part	Description
22	PCXRJ-AD		1.44 MB Floppy Disk Drive Frost White Flat Bezel Generic
	PCXRJ-AA		Floppy Disk Drive, 3.5", 3 Mode
23	RE-45B-E		850 MB IDE Disk Drive, 4500RPM, Quantum Trailblazer
	PCXRA-AL		1.6 GB IDE Disk Drive, 5200RPM, Western Digital
	PCXRA-AI		Hard Drive 640 MB FB640AT IDE 5400RPM Quantum
	PCXRE-AB		1280 MB Narrow SCSI Drive Quantum
	PCXRA-AM		2.5 GB HDD
	PCXRE-AA		Hard Drive 1 GB SCSI Narrow Quantum
	RZ28C-E		2.0 GB SCSI HDD
24	PCXRN-AA		6x IDE CD-ROM Drive
	PCXRN-AF		8x IDE CD-ROM Drive
	30-45370-01		5.25" SCSI 4x CD-ROM Drive
	PCXAT-DA		Conner External SCSI Tape Drive
	TZK11-AA		2/4 GB QIC SCSI Internal
	TLZ07		4.0/8.0 GB RDAT Drive
25	74-49365-01		Holder, Drive Rail
N/I ⁽¹⁾	90-08020-01		Screw, Machine 6-32 PAN .187 XRCS (HDD)
N/I ⁽¹⁾	90-40217-01		Screw, Machine M3 PAN 5MM XRCS CSZ (FDD and CD-ROM)
N/I ⁽¹⁾	74-48510-01		Exchange Bracket 5.25" to 3.5"
N/I ⁽¹⁾	90-10961-01		Screw, Machine M3 PAN 4MM XRCS SSP (CD-ROM)

⁽¹⁾ N/I = Not Illustrated

Cables

Orderable Spare Part	Exchangeable Spare Part	Description
17-03460-12		Cable, Floppy
17-03461-11		IDE, Flat Cable
17-04372-02		Cable, Control Panel
17-04373-01		Wire Assembly, Audio
17-04371-01		Wire Assembly, Video
30-43624-07		Audio Cable, CD-ROM

Nameplates

Orderable Spare Part	Exchangeable Spare Part	Description
74-48816-01		Digital Medallion
74-51175-02		Nameplate, Venturis FX
74-51176-03		Speed Button, 575s
74-51176-05		Speed Button, 5100s
74-51176-07		Speed Button, 5120s
74-51176-09		Speed Button, 5133s
74-51176-11		Speed Button, 5150s
74-51176-13		Speed Button, 5166s
74-51176-20		Speed Button, 575sm
74-51176-21		Speed Button, 5100sm
74-51176-22		Speed Button, 5120sm
74-51176-23		Speed Button, 5133sm
74-51176-24		Speed Button, 5150sm
74-51176-25		Speed Button, 5166sm

Miscellaneous

Orderable Spare Part	Exchangeable Spare Part	Description
21-44145-38	21-40847-38 21-44141-38	1 MB Video DRAM EDO 50 ns 256KX16X2 Upgrade
PCXJF-AA		Headset Labtec C-10
PCXJB-AC		Microphone Goldtron
PCXLN-AA		2-button Mouse White, Retail, Bulk Packaged
30-46117-02		3-button Mouse, White
PCXJA-AG		Midiland Speaker 7W w/ PWR Adapter
PCXJA-AF		Midiland Speaker 7W w/o PWR Adapter
PCXJA-AE		Midiland Speaker 10W w/ PWR Adapter
PCXJA-AD		Midiland Speaker 10W w/o PWR Adapter
PCXZA-AA		Adaptec 1540CP PnP
PCXZA-AB		Adaptec 1540CF ISA (Japan)
PCXJD-AB		Creative Labs PnP Sound Card
12-41670-01		Terminator, SCSI, 50P IDC, Single End
17-03895-03		Cable Assy, Non-Mold, Flat, RCPT (SCSI Internal)
30-42291-01		28.8 K Data/28.8 Fax Modem
30-42551-01		Adaptec 2940 PCI
30-44396-03		Ensonic Wave Card
30-47658-01		Power Adapter 12v DC 220V AC for Midiland Speakers
30-47657-01		Power Adapter 12v DC 240V AC for Midiland Speakers
30-47659-01		Power Adapter 12v DC 110/120V AC for Midiland Speakers
74-49836-01		Bumper for MLB

VENTURIS FX and CELEBRIS FX

Service Procedures

The following sections provide detailed service instructions for Venturis FX and Celebris FX computers.



CAUTION: Static electricity collects on non-conductors such as paper, cloth, or plastic. A static discharge can be damaging even though you often cannot see or feel it. To prevent damage to circuit boards and/or components:

- Before touching any circuit board or component, touch the metal frame of the computer to discharge any static electricity.
- Keep circuit boards and components away from non-conductors.

Recommended Tools

Have the following tools available:

- Multimeter (4½-inch digit)
- Phillips screwdriver
- Antistatic wrist strap (recommended, but not required)

Other Materials Needed

Cleaning agent should be an all purpose cleaner that is used in-house.

Special Tools Required

None.

Remedial Diagnostic Test Software

Supplier information:

AMI Diagnostics
6145-F Northbelt Parkway
Norcross, GA 30071, U.S.A.
Voice: 1-770-246-8600
FAX: 1-770-246-8791
Support: 1-770-246-8645
Internet: <http://www.megatrends.com>

Virus Software Information

F-PROT, Virus Detection and Cleanup Software, latest version.

Supplier information:

North America, South America, Australia and New Zealand
Command software Systems Inc.
Tel: +1-407-575 3200
FAX: 1-407-575-3026

BIOS Version Information

Refer to the Digital Bulletin Board Service (BBS) for the latest information on BIOS upgrades by calling:

In the United States: (508) 496-8800

Disconnect External Devices and Power

1. Turn off power to all external devices connected to computer.
2. Turn the computer off.
3. Disconnect power from the wall outlet.
4. Disconnect the power cord and monitor cord.

Removing the Outside Cover

To remove your computer's outside cover:

1. Remove the outside cover by loosening the thumbscrew(s) at the rear of your computer.
2. Slide the outside cover forward for the low profile and backwards for the short tower.
3. Carefully lift the outside cover away from the chassis.

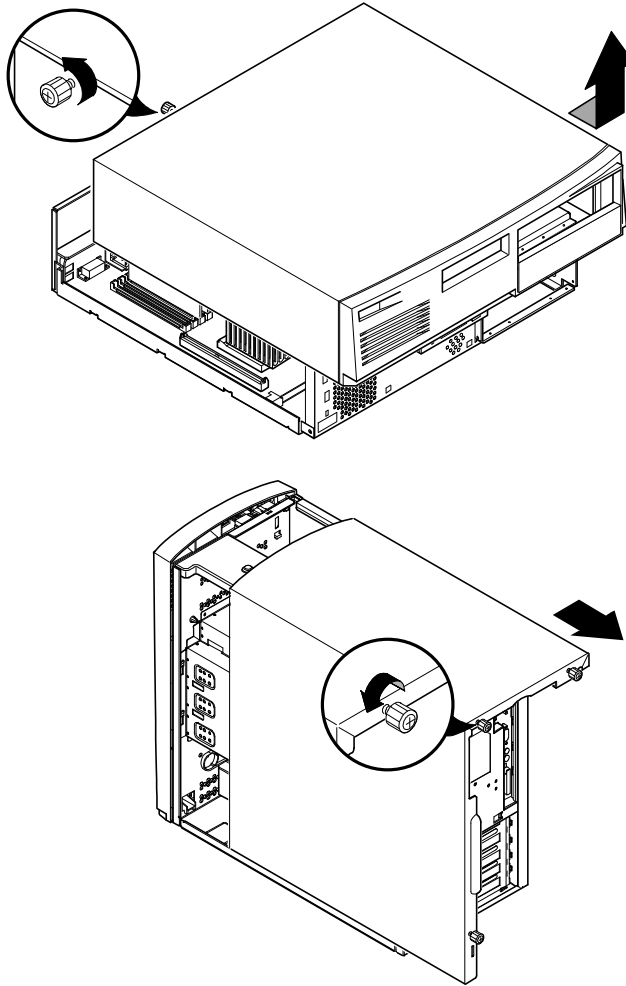

VENTURIS FX and CELEBRIS FX

DEC00749-2

Figure 5-3. Removing the Outside Cover

Computer Components

The following sections identify the Venturis FX and Celebris FX computer components including: main logic components, main logic board connectors (rear panel), main logic board connectors, backplane components, expansion slots, main logic board jumper locations, and memory configurations.

Main Logic Board Components

Figure Legend	Component
A	Onboard EDO video memory
B	S3 series video controller
C	Keyboard controller
D	PCI-to-ISA bridge
E	Super I/O controller
F	Computer battery
G	Computer flash and video BIOS
H	Cache memory controller
I	Voltage regulator module (VRM)
J	Microprocessor (CPU)
K	PCI local data buffer
L	16-bit stereo sound chip (Venturis FXsm only)

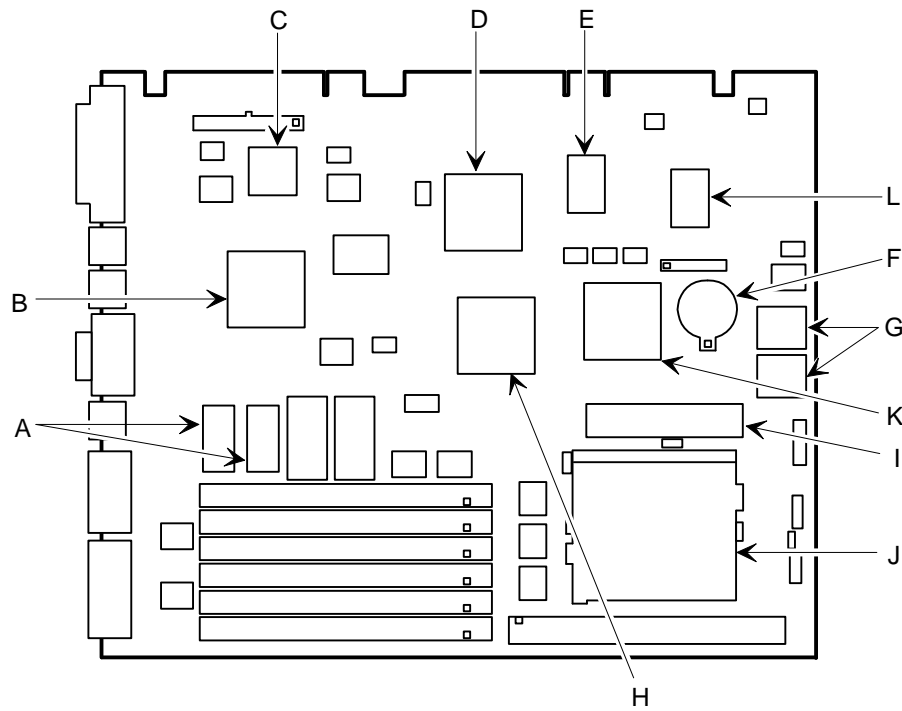

DEC00752-2

Figure 5-4. Main Logic Board Components

VENTURIS FX and CELEBRIS FX

Main Logic Board Connectors (Rear Panel)

Figure Legend	Connector
A	Parallel port
B	Keyboard port
C	Mouse port
D	Video (VGA) port (not applicable on Celebris FX computers with Matrox video cards)
E	Two USB ports (not available on some models)
F	Two serial ports, stacked (COM1 top, COM2 bottom)
G	MIDI/joystick port (Venturis FXsm only)

VENTURIS FX and CELEBRIS FX

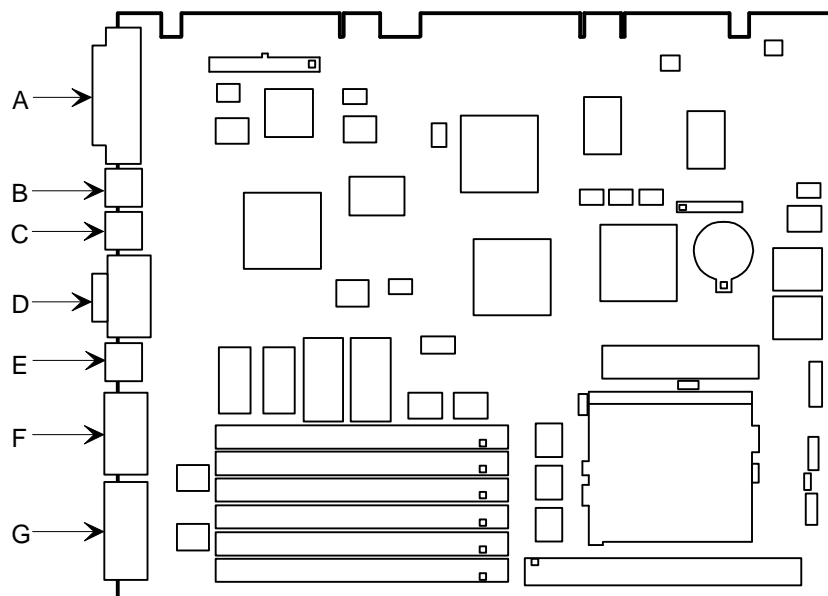

VENTURIS FX and CELEBRIS FX

DEC00752-3

Figure 5-5. Main Logic Board Components (Rear Panel)

Main Logic Board Connectors

Figure Legend	Connector
A	Video memory upgrade sockets (not available on some models)
B	MPEG connectors (not available on some models)
C	WaveTable connector (Venturis FXsm only)
D	Auxiliary fan power
E	CPU socket
F	Secondary cache module [COAST (Cache On A Stick) standard module]
G	Four or six 72-pin, 32-bit SIMM sockets (depending on your model)

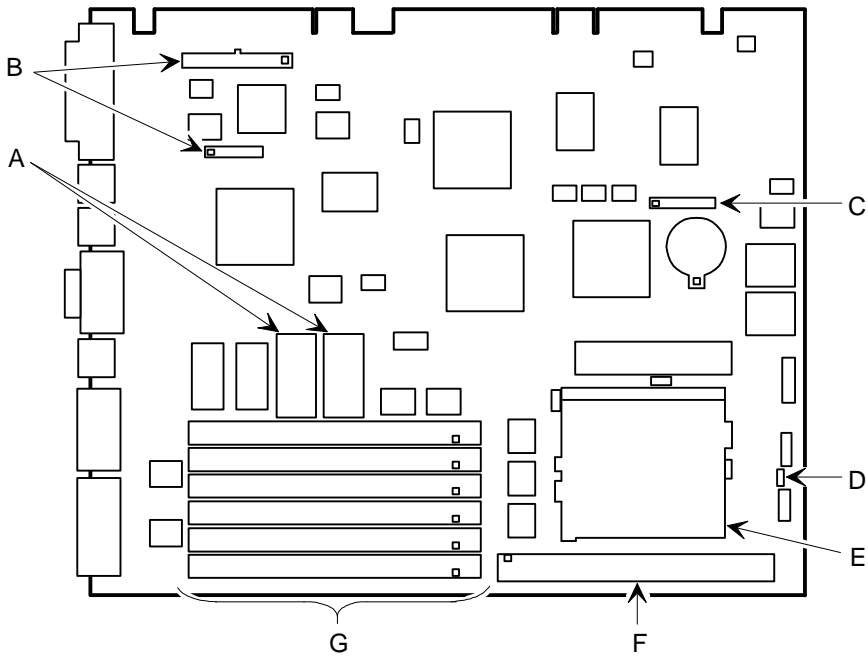

DEC00752-4

VENTURIS FX and CELEBRIS FX

Figure 5-6. Main Logic Board Connectors

Venturis FX Low Profile Backplane Components and Connectors

VENTURIS FX and CELEBRIS FX

Figure Legend	Connector
A	PCI expansion board connectors
B	ISA expansion board connectors
C	Primary PCI IDE drive connector
D	Secondary PCI IDE drive connector (recommended for CD-ROM drive connection)
E	Diskette drive connector
F	SCSI LED connector
G	Fan connector
H	Front panel connector
I	Power connector
J	Main logic board connectors

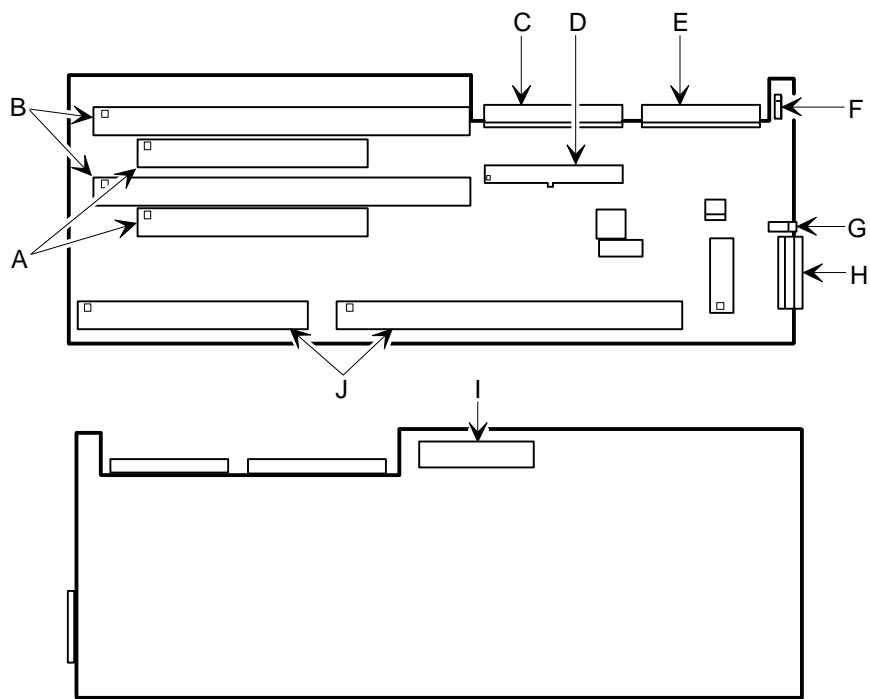

VENTURIS FX and CELEBRIS FX

DEC00753-2

Figure 5-7. Venturis FX Low Profile Backplane Components and Connectors

Celebris FX Low Profile Backplane Components and Connectors

VENTURIS FX and CELEBRIS FX

Figure Legend	Connector
A	PCI expansion board connectors
B	ISA expansion board connectors
C	Primary PCI IDE drive connector
D	Secondary PCI IDE drive connector (recommended for CD-ROM drive connection)
E	Diskette drive connector
F	T/P IN connector (Twisted-Pair) (not available on all models)
G	SCSI LED connector
H	Fan connector
I	Front panel connector
J	Digital PCI Ethernet controller (not available on all models)
K	Power connector
L	Main logic board connectors

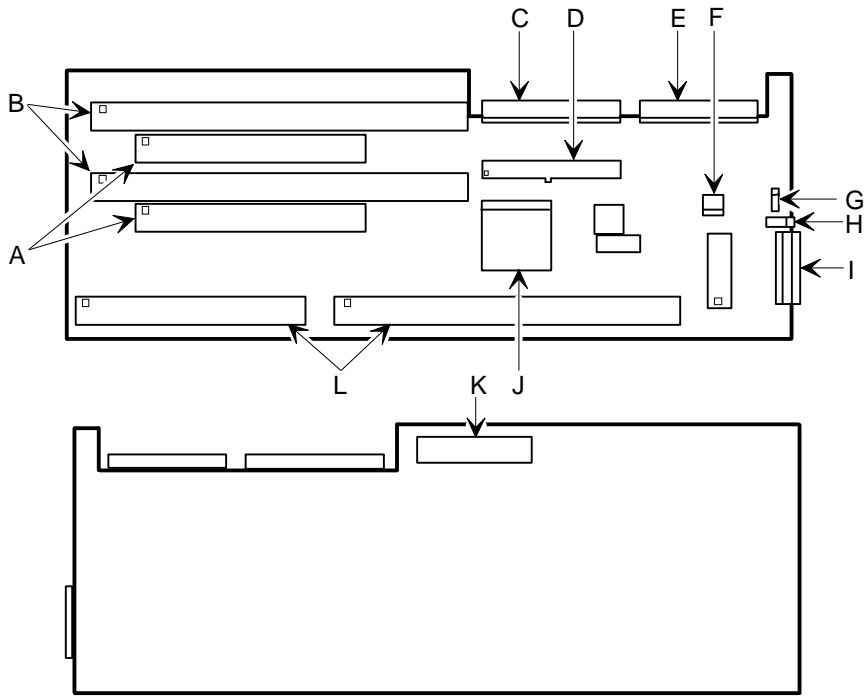

VENTURIS FX and CELEBRIS FX

DEC00985-2

Figure 5-8. Celebris FX Low Profile Backplane Components and Connectors

Venturis FX Short Tower Backplane Components and Connectors

VENTURIS FX and CELEBRIS FX

Figure Legend	Connector
A	Front panel connector
B	CD-ROM audio input connector (CD-IN) (Venturis FXsm only)
C	SCSI LED connector
D	Primary PCI IDE drive connector
E	Secondary PCI IDE drive connector (recommended for CD-ROM drive connection)
F	Main logic board connectors
G	Power connector
H	Audio out connector (Venturis FXsm only)
I	PCI expansion board connectors
J	Fan 2 connector
K	ISA expansion board connectors
L	Diskette drive connector
M	Audio IN connector (Venturis FXsm only)
N	Fan 3 connector
O	Spatializer 3-D stereo chip (Venturis FXsm only)

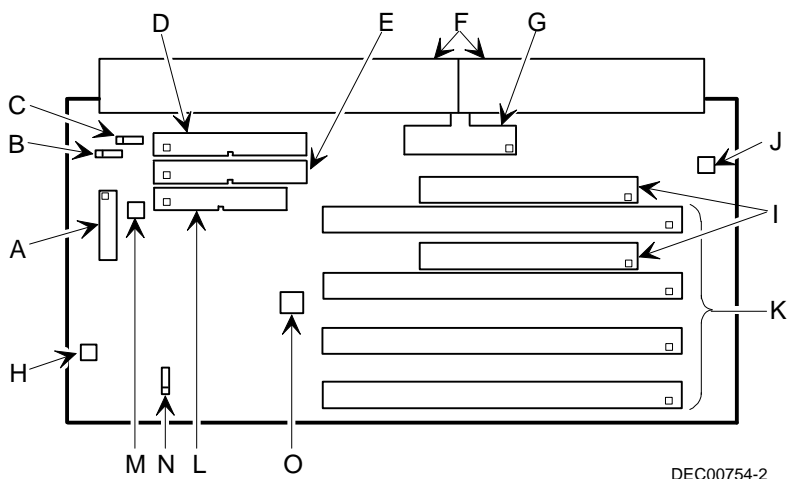

Figure 5-9. Venturis FX Short Tower Backplane Components and Connectors

VENTURIS FX and CELEBRIS FX

Expansion Slots (Venturis FX and Celebris FX Low Profile)

VENTURIS FX and CELEBRIS FX

Expansion Slot Designation	Description
ISA2	Supports half-length industry-standard 16-bit ISA expansion boards Uses the top expansion slot at the rear panel
PCI2	Supports half-length 32-bit PCI local bus expansion boards Uses the middle expansion slot at the rear panel Designated as a shared slot with ISA slot ISA1 ⁽¹⁾
ISA1	Supports full-length industry-standard 16-bit ISA expansion boards Uses the middle expansion slot at the rear panel Designated as a shared slot with PCI slot PCI2 ⁽¹⁾
PCI1	Supports full-length 32-bit PCI local bus expansion boards Uses the bottom expansion slot at the rear panel

⁽¹⁾ Only one expansion board can reside in slot PCI2 and ISA1 at any one time. These slots have to share the middle expansion slot opening at the rear panel, thus, a maximum of three expansion boards can be supported at any one time.

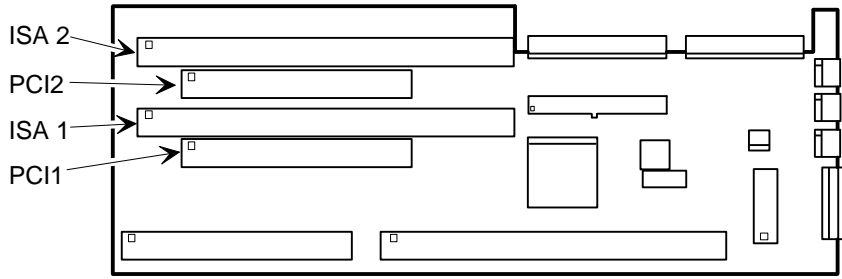

DEC00753-3

Figure 5-10. Expansion Board Slots (Venturis FX and Celebris FX Low Profile)

VENTURIS FX and CELEBRIS FX

Expansion Slots (Venturis FX Short Tower)

VENTURIS FX and CELEBRIS FX

Expansion Slot Designation	Description
ISA2-ISA4	Supports full-length industry-standard 16-bit ISA expansion boards Uses the first, second, and third (bottom three) expansion slots at the rear panel
PCI2	Supports full-length 32-bit PCI local bus expansion boards Uses the fourth expansion slot at the rear panel Designated as a shared slot with ISA slot ISA1 ⁽¹⁾
ISA1	Supports half-length industry-standard 16-bit ISA expansion boards Uses the fourth expansion slot at the rear panel Designated as a shared slot with PCI slot PCI2 ⁽¹⁾
PCI1	Supports half-length 32-bit PCI local bus expansion boards Uses the fifth (top) expansion slot at the rear panel

⁽¹⁾ Only one expansion board can reside in slot PCI2 and ISA1 at any one time. These slots have to share the third expansion slot opening at the rear panel, thus, a maximum of five expansion boards can be supported at any one time.

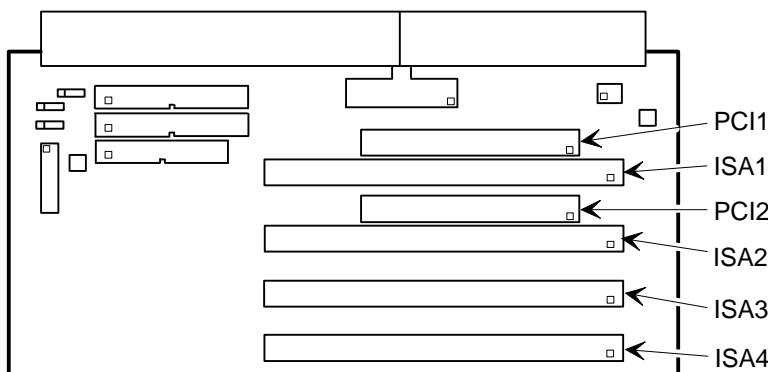

DEC00754-3

Figure 5-11. Expansion Board Slots (Venturis FX Short Tower)

VENTURIS FX and CELEBRIS FX

Main Logic Board Jumper Settings

Feature	Function	Setting	Description
CMOS clear	Discharge Normal ⁽¹⁾	J3, 4-5, jumpered J3, 5-6, jumpered ⁽¹⁾	Clears CMOS of all BIOS information when jumper is set for Discharge. Use the Discharge setting when you need to reconfigure your computer's resources. After discharging CMOS, you must reset the jumper to Normal before rebooting your computer.
Recovery mode	Recovery mode Normal ⁽¹⁾	J1, 3-4, jumpered J1, 3-4, unjumpered ⁽¹⁾	Enables you to boot from a Recovery Disk should an error occur while you are flashing the BIOS.
Boot block update	Enabled Disabled ⁽¹⁾	J3, 1-2, jumpered J3, 2-3, jumpered ⁽¹⁾	Set this jumper to disabled to prevent unauthorized personnel from changing the BIOS boot block.
Password clear	Password clear (MFG test) Normal mode ⁽¹⁾	J1, 1-2, jumpered J1, 1-2, unjumpered ⁽¹⁾	If you forget your password, set this jumper to password clear and then restart the computer.
ASYNC/ Pipe burst SRAM	ASYNC Burst ⁽¹⁾	J3, 7-8, jumpered J3, 8-9, jumpered ⁽¹⁾	This setting determines how the SRAM, cache memory is addressed and used.
Factory setting		J1, 13-14	Reserved.

(1) Factory default setting

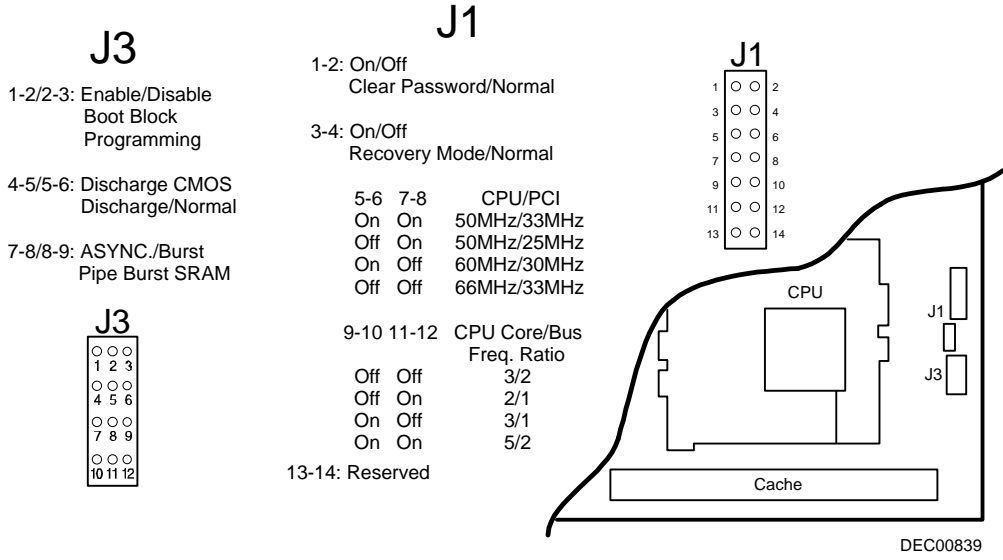

VENTURIS FX and CELEBRIS FX

Figure 5-12. Main Logic Board Jumper Locations

Processor Jumper Settings

Pentium Processor	J1 Pin Settings				
	In MHz	Pins 5 and 6	Pins 7 and 8	Pins 9 and 10	Pins 11 and 12
75	On	On	Off	Off	Off
100	Off	Off	Off	Off	Off
120	On	Off	Off	Off	On
133	Off	Off	Off	Off	On
150	On	Off	On	On	On
166	Off	Off	On	On	On
200	Off	Off	On	On	Off

Some processors might be unavailable or others might be introduced.

Installing Additional Computer Memory

Adding more memory enables your computer to run larger, more complicated software and run it more quickly.

Depending on the model you purchased, your computer comes with either 8 MB or 16 MB of Extended Data Out (EDO) memory. For those with 8 MB computers, memory is installed as two 4 MB SIMMs in bank 0 (socket J11 and J12). For those with 16 MB computers, memory is installed as two 8 MB SIMMs in bank 0 (socket J11 and J12). When adding memory, you need to use 72-pin SIMMs (Figure 5-13).

For some models, you can increase this amount up to a maximum of 128 MB using the four SIMM sockets on the main logic board. All other models, including all models of the Celebris FX, can be increased up to 192 MB using the six SIMM sockets on the main logic board.

All Venturis FX and Celebris FX computers support EDO memory. EDO memory, in pairs of 4 MB, 8 MB, 16 MB, and 32 MB SIMMs, is faster than standard non-parity or Fast Page memory. Contact your local Digital sales representative for ordering information.

When adding SIMMs make sure you:

- Install 32-bit SIMMs having an access time of 70 ns or less. Supported SIMM sizes: 4 MB, 8 MB, 16 MB or 32 MB (60 ns for EDO DRAM).
- Although you can add a single SIMM of memory, for maximum performance you should populate both SIMM sockets in a given bank.
- If you populate both SIMM sockets in a given bank, you must use the same type and size memory. For example, if you add 8 MB of EDO memory in socket 3 (J10), and decide to add another 8 MB, you must use 8 MB of EDO memory in socket 4 (J9).
- You can mix EDO and fast paged memory, but not in the same bank.

Refer to "Memory Configurations" for a list of SIMM combinations supported by your Venturis FX and Celebris FX computer and to "Installing a SIMM" for detailed instructions on installing SIMMs.

VENTURIS FX and CELEBRIS FX

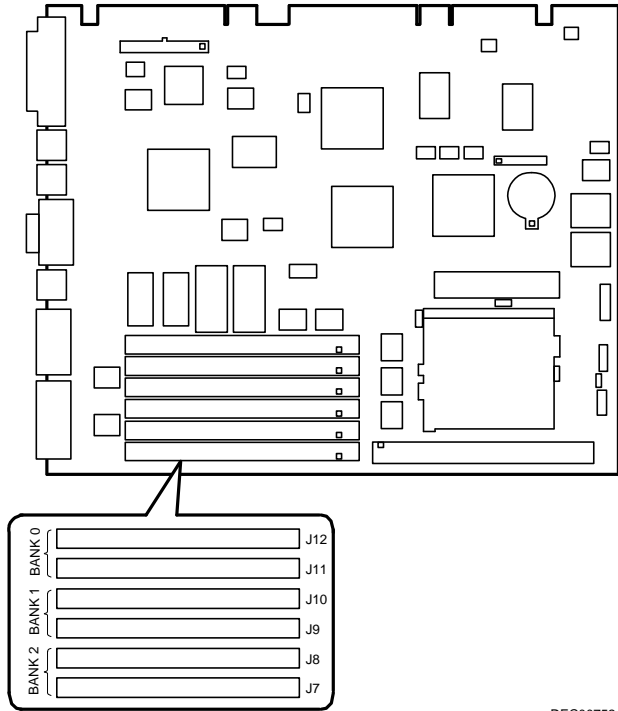

DEC00752-5

Figure 5-13. SIMM Socket Locations for Most Models (Some Models Have 4 SIMM Sockets)

Memory Configurations

Socket J12	Socket J11	Socket J10	Socket J9	Socket J8 ⁽¹⁾	Socket J7 ⁽¹⁾	Total
4 MB	4 MB					8 MB
4 MB	4 MB	4 MB				12 MB
4 MB	4 MB	8 MB				16 MB
4 MB	4 MB	16 MB				24 MB
4 MB	4 MB	32 MB				40 MB
4 MB	4 MB	4 MB	4 MB			16 MB
4 MB	4 MB	4 MB	4 MB	4 MB		20 MB
4 MB	4 MB	4 MB	4 MB	8 MB		24 MB
4 MB	4 MB	4 MB	4 MB	16 MB		32 MB
4 MB	4 MB	4 MB	4 MB	4 MB	32 MB	48 MB
4 MB	4 MB	8 MB	8 MB			24 MB
4 MB	4 MB	16 MB	16 MB			40 MB
4 MB	4 MB	32 MB	32 MB			72 MB
8 MB						8 MB
8 MB	8 MB					16 MB
8 MB	8 MB	4 MB				20 MB
8 MB	8 MB	8 MB				24 MB
8 MB	8 MB	16 MB				32 MB
8 MB	8 MB	32 MB				48 MB
8 MB	8 MB	8 MB	8 MB			32 MB
8 MB	8 MB	8 MB	8 MB	4 MB		36 MB
8 MB	8 MB	8 MB	8 MB	8 MB		40 MB
8 MB	8 MB	8 MB	8 MB	16 MB		48 MB
8 MB	8 MB	8 MB	8 MB	32 MB		64 MB
8 MB	8 MB	8 MB	8 MB	8 MB	8 MB	48 MB
8 MB	8 MB	8 MB	8 MB	16 MB	16 MB	64 MB
8 MB	8 MB	8 MB	8 MB	32 MB	32 MB	96 MB
8 MB	8 MB	16 MB	16 MB			48 MB
8 MB	8 MB	16 MB	16 MB	4 MB		52 MB
8 MB	8 MB	16 MB	16 MB	8 MB		56 MB
8 MB	8 MB	16 MB	16 MB	16 MB		64 MB
8 MB	8 MB	16 MB	16 MB	32 MB		80 MB
8 MB	8 MB	16 MB	16 MB	8 MB	8 MB	64 MB
8 MB	8 MB	16 MB	16 MB	16 MB	16 MB	80 MB
8 MB	8 MB	16 MB	16 MB	32 MB	32 MB	112 MB
8 MB	8 MB	32 MB	32 MB			80 MB
8 MB	8 MB	32 MB	32 MB	4 MB		84 MB
8 MB	8 MB	32 MB	32 MB	8 MB		88 MB

VENTURIS FX and CELEBRIS FX

(1) Sockets not installed on some models

continued

VENTURIS FX and CELEBRIS FX

Socket J12	Socket J11	Socket J10	Socket J9	Socket J8 ⁽¹⁾	Socket J7 ⁽¹⁾	Total
8 MB	8 MB	32 MB	32 MB	16 MB		96 MB
8 MB	8 MB	32 MB	32 MB	32 MB		112 MB
8 MB	8 MB	32 MB	32 MB	8 MB	8 MB	96 MB
8 MB	8 MB	32 MB	32 MB	16 MB	16 MB	112 MB
16 MB						16 MB
16 MB	16 MB					32 MB
16 MB	16 MB	4 MB				36 MB
16 MB	16 MB	8 MB				40 MB
16 MB	16 MB	16 MB				48 MB
16 MB	16 MB	32 MB				64 MB
16 MB	16 MB	8 MB	8 MB			48 MB
16 MB	16 MB	8 MB	8 MB	4 MB		52 MB
16 MB	16 MB	8 MB	8 MB	8 MB		56 MB
16 MB	16 MB	8 MB	8 MB	16 MB		64 MB
16 MB	16 MB	8 MB	8 MB	32 MB		80 MB
16 MB	16 MB	8 MB	8 MB	8 MB	8 MB	64 MB
16 MB	16 MB	8 MB	8 MB	16 MB	16 MB	80 MB
16 MB	16 MB	8 MB	8 MB	32 MB	32 MB	112 MB
16 MB	16 MB	16 MB	16 MB			64 MB
16 MB	16 MB	16 MB	16 MB	4 MB		68 MB
16 MB	16 MB	16 MB	16 MB	8 MB		72 MB
16 MB	16 MB	16 MB	16 MB	16 MB		80 MB
16 MB	16 MB	16 MB	16 MB	32 MB		96 MB
16 MB	16 MB	16 MB	16 MB	8 MB	8 MB	80 MB
16 MB	16 MB	16 MB	16 MB	16 MB	16 MB	96 MB
16 MB	16 MB	16 MB	16 MB	32 MB	32 MB	128 MB
16 MB	16 MB	32 MB	32MB			96 MB
16 MB	16 MB	32 MB	32MB	4 MB		100 MB
16 MB	16 MB	32 MB	32MB	8 MB		104 MB
16 MB	16 MB	32 MB	32MB	16 MB		112 MB
16 MB	16 MB	32 MB	32MB	32 MB		128 MB
16 MB	16 MB	32 MB	32MB	8 MB	8 MB	112 MB
16 MB	16 MB	32 MB	32MB	16 MB	16 MB	128 MB
32 MB						32 MB
32 MB	32 MB					64 MB
32 MB	32 MB	4 MB				68 MB
32 MB	32 MB	8 MB				72 MB

(1) Sockets not installed on some models

continued

Socket J12	Socket J11	Socket J10	Socket J9	Socket J8 ⁽¹⁾	Socket J7 ⁽¹⁾	Total
32 MB	32 MB	16 MB				80 MB
32 MB	32 MB	32 MB				96 MB
32 MB	32 MB	8 MB	8 MB			80 MB
32 MB	32 MB	8 MB	8 MB	4 MB		84 MB
32 MB	32 MB	8 MB	8 MB	8 MB		88 MB
32 MB	32 MB	8 MB	8 MB	16 MB		96 MB
32 MB	32 MB	8 MB	8 MB	32 MB		112 MB
32 MB	32 MB	8 MB	8 MB	8 MB	8 MB	96 MB
32 MB	32 MB	8 MB	8 MB	16 MB	16 MB	112 MB
32 MB	32 MB	16 MB	16 MB			96 MB
32 MB	32 MB	16 MB	16 MB	4 MB		100 MB
32 MB	32 MB	16 MB	16 MB	8 MB		104 MB
32 MB	32 MB	16 MB	16 MB	16 MB		112 MB
32 MB	32 MB	16 MB	16 MB	32 MB		128 MB
32 MB	32 MB	16 MB	16 MB	8 MB	8 MB	112 MB
32 MB	32 MB	32 MB	32 MB			128 MB
32 MB	32 MB	32 MB	32 MB	4 MB		132 MB
32 MB	32 MB	32 MB	32 MB	8 MB		136 MB
32 MB	32 MB	32 MB	32 MB	16 MB		144 MB
32 MB	32 MB	32 MB	32 MB	32 MB		160 MB
32 MB	32 MB	32 MB	32 MB	8 MB	8 MB	144 MB
32 MB	32 MB	32 MB	32 MB	16 MB	16 MB	160 MB
32 MB	32 MB	32 MB	32 MB	32 MB	32 MB	192 MB

VENTURIS FX and CELEBRIS FX

(1) Sockets not installed on some models

Removing and Replacing Components

The following sections provide removal and replacement procedures for the following Venturis FX and Celebris FX components:

- Main logic board
- Adapter card
- SIMMs
- Secondary cache module
- Video memory
- Battery
- Heat sink
- Processor
- VRM
- Backplanes
- Expansion boards
- Power supplies
- Control panels
- Air duct
- Fans
- 3½-inch mass storage devices
- 5¼-inch mass storage devices

Removing the Main Logic Board

1. Turn off the computer and monitor.
2. Disconnect all external devices, ac power, and monitor power.
3. Remove the outside cover.
4. Swing the right side of the brace away from the chassis (Celebris FX low profile only).
5. Pull up on the two latches attached to the main logic board.
6. Carefully remove the main logic board from the chassis.



NOTE: When replacing the main logic board, you must move to the replacement main logic board, the processor chip and other components, such as SIMMs. The processor chip and the heat sink assembly should be removed and reinstalled as a single assembly. There is no need to disassemble the processor chip and heat sink.

VENTURIS FX and CELEBRIS FX

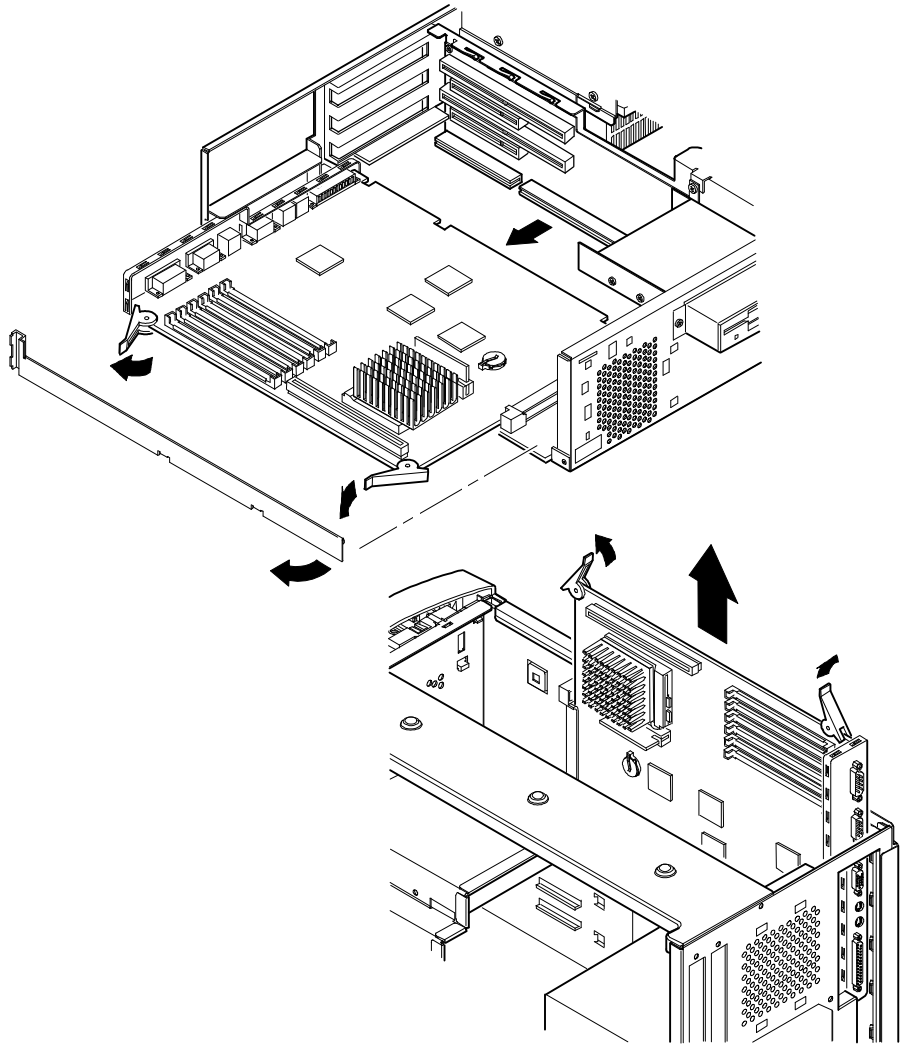

DEC00958

Figure 5-14. Removing the Main Logic Board

Removing an Adapter Card

1. Turn off the computer, monitor, and then disconnect power from the computer.
2. Remove the outside cover.
3. Disconnect the adapter card cable(s).
4. Remove the adapter card.
5. Remove the adapter card from the bracket by unscrewing the two screws that hold the adapter card to the bracket.

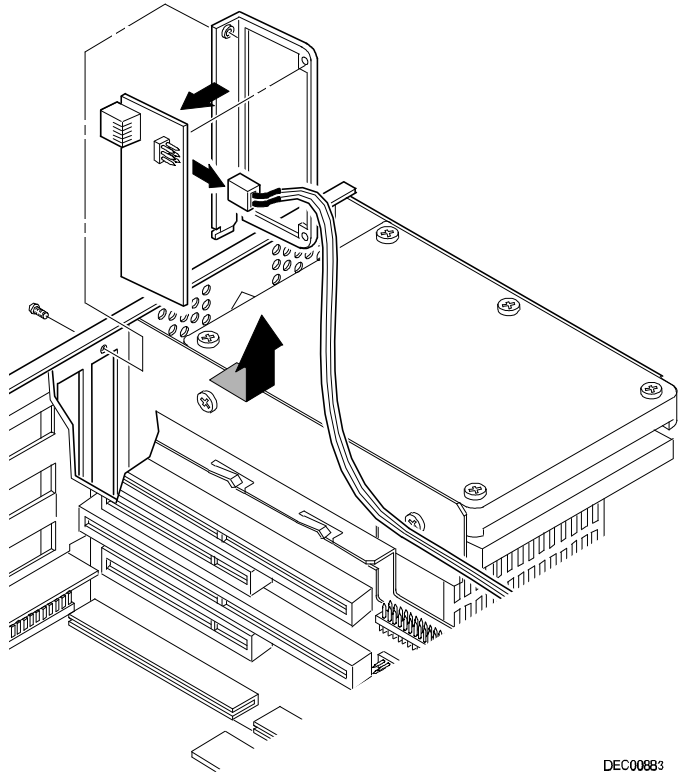

DEC00883

Figure 5-15. Removing an Adapter Card

Removing the SIMMs

1. Turn off the computer, monitor, and then disconnect power from the computer.
2. Remove the outside cover.
3. Press the SIMM retaining clips out.
4. Push the SIMM down and pull it out of the socket.

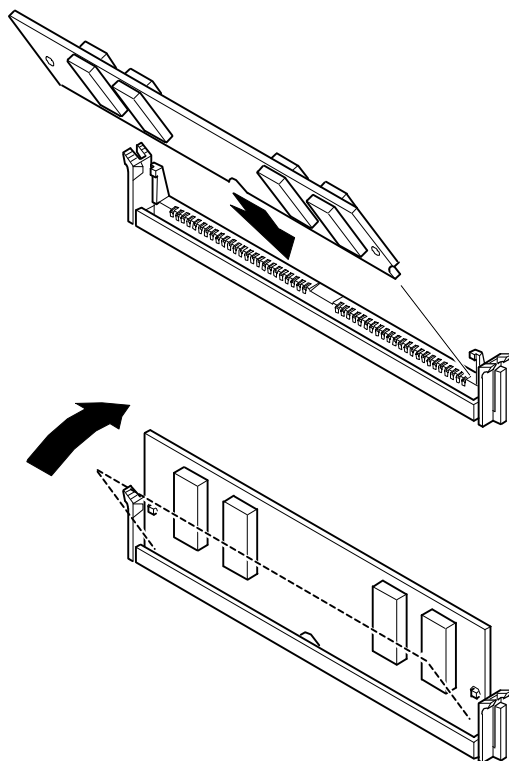

DEC00921

Figure 5-16. Removing SIMMs

Removing the Secondary Cache Module

1. Turn off the computer, monitor, and then disconnect power from the computer.
2. Remove the outside cover.
3. Remove the secondary cache module by pulling it straight up.

VENTURIS FX and CELEBRIS FX

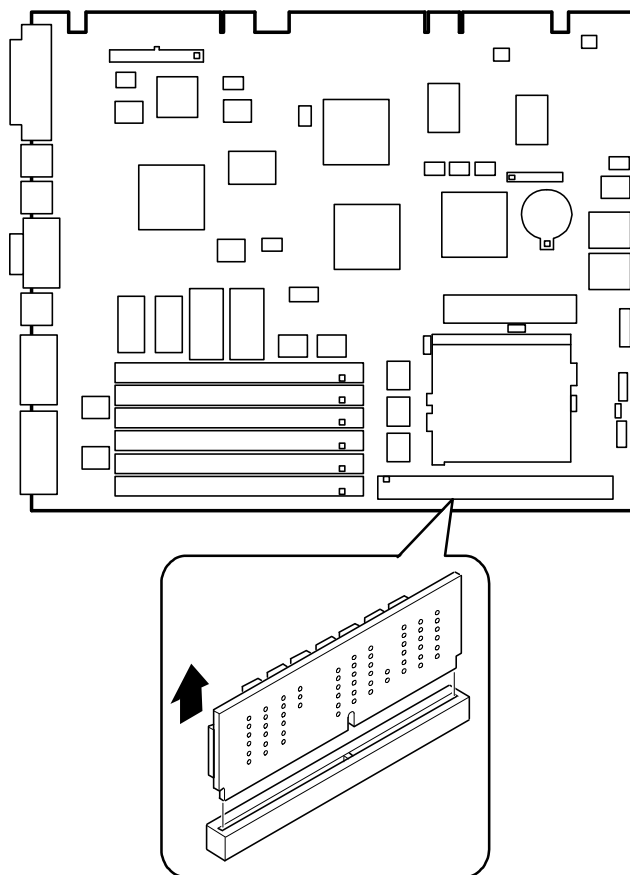

DEC00752-7

Figure 5-17. Removing a Secondary Cache Module

Removing Video Memory (S3)

1. Turn off the computer, monitor, and then disconnect power from the computer.
2. Remove the outside cover.
3. If the computer is a short tower, remove main logic board. If the computer is a low profile, you might have to remove main logic board, otherwise go to step 4.
4. Remove the video memory by inserting a small screwdriver at the notch and then prying out the chip.



CAUTION: Be careful not to damage the pins or the socket.

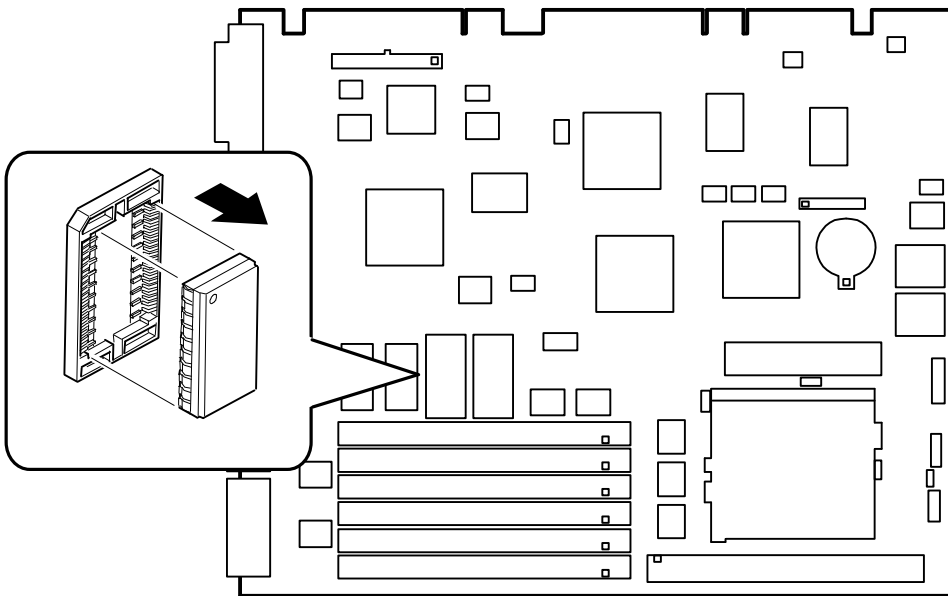

DEC00752-19

Figure 5-18. Removing Video Memory

Removing a WaveTable Daughter Card

1. Turn off the computer, monitor, and then disconnect power from the computer.
2. Remove the outside cover.
3. Remove the main logic board.
4. Remove the WaveTable daughter card by pulling it straight up.

VENTURIS FX and CELEBRIS FX

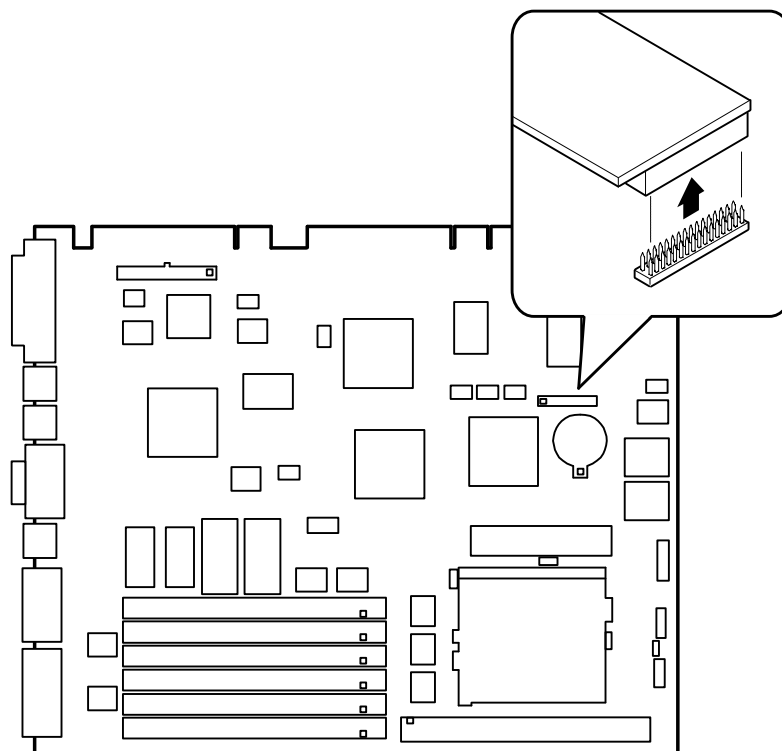

DEC00752-11

Figure 5-19. Removing a WaveTable Daughter Card

Removing the Lithium Battery

1. Turn off the computer, monitor, and then disconnect power from the computer.
2. Remove the outside cover.
3. Remove the main logic board.
4. Remove the old battery.



WARNING: There is a danger of battery explosion if a lithium battery is incorrectly replaced. To prevent damage to the computer, be sure the + side faces up when installing a new battery. Also, be sure you replace the battery with either a Digital (P/N 12-41474-05), Toshiba (P/N CR2032), or equivalent 3 V dc lithium battery.

Depending on the locality, the computer's battery might be considered hazardous waste. Make sure you follow any state or local statute to properly dispose of the old battery.

VENTURIS FX and CELEBRIS FX

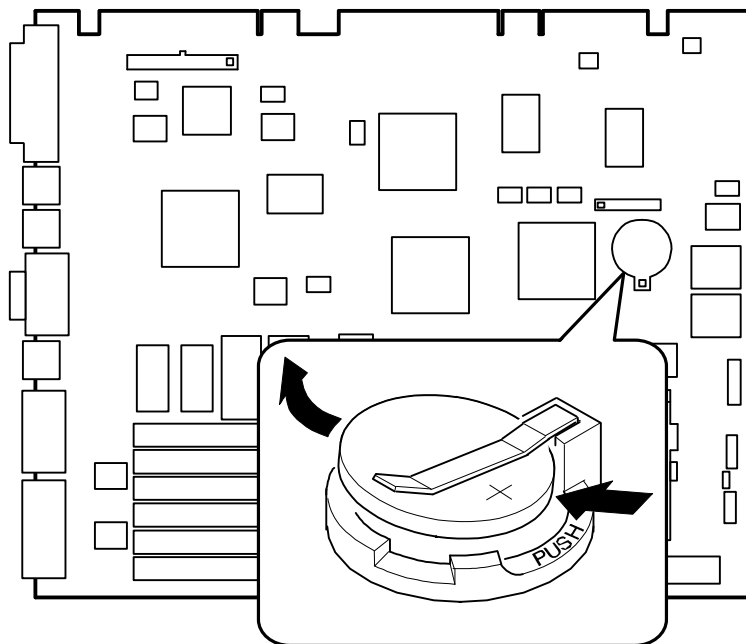

DEC00752-8

Figure 5-20. Removing the Lithium Battery

Removing the Processor Heat Sink

1. Turn off the computer, monitor, and then disconnect power from the computer.
2. Remove the outside cover.
3. Remove the main logic board.
4. Remove the heat sink clips.
5. Remove the heat sink.

To remove the heat sink, slide it off to the side. Do not try to lift it straight up.



NOTE: Between the heat sink and the processor is thermal compound to form a good thermal bond. When you replace the processor and heat sink, first insert the processor chip in the socket and move the lever down. Next spread the thermal compound on the heat sink. Place the heat sink on top of the processor and then secure the heat sink with the heat sink clip.

VENTURIS FX and CELEBRIS FX

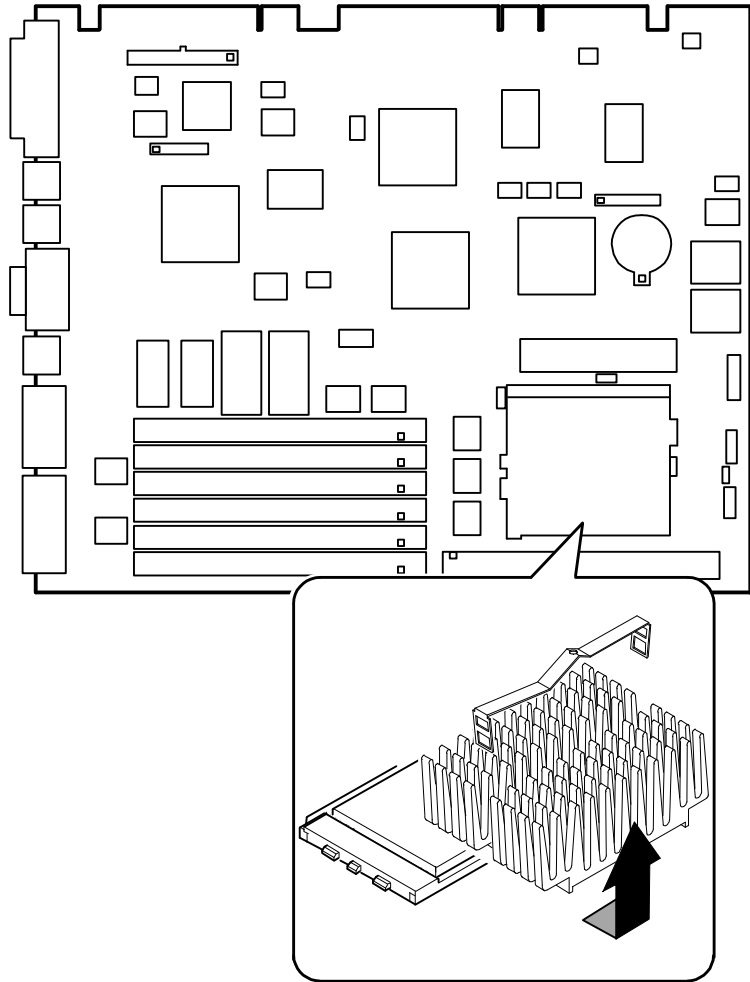

DEC00752-21

Figure 5-21. Removing the Processor Heat Sink

Removing the Processor

1. Turn off the computer, monitor, and then disconnect power from the computer.
2. Remove the outside cover.
3. Remove the main logic board.
4. If necessary, remove the VRM or VRE module.
5. Remove the heat sink.
6. Lift the lever out and then up.
7. Remove the processor.

Refer to “Remove Processor Heat Sink” for processor replacement procedures.

VENTURIS FX and CELEBRIS FX

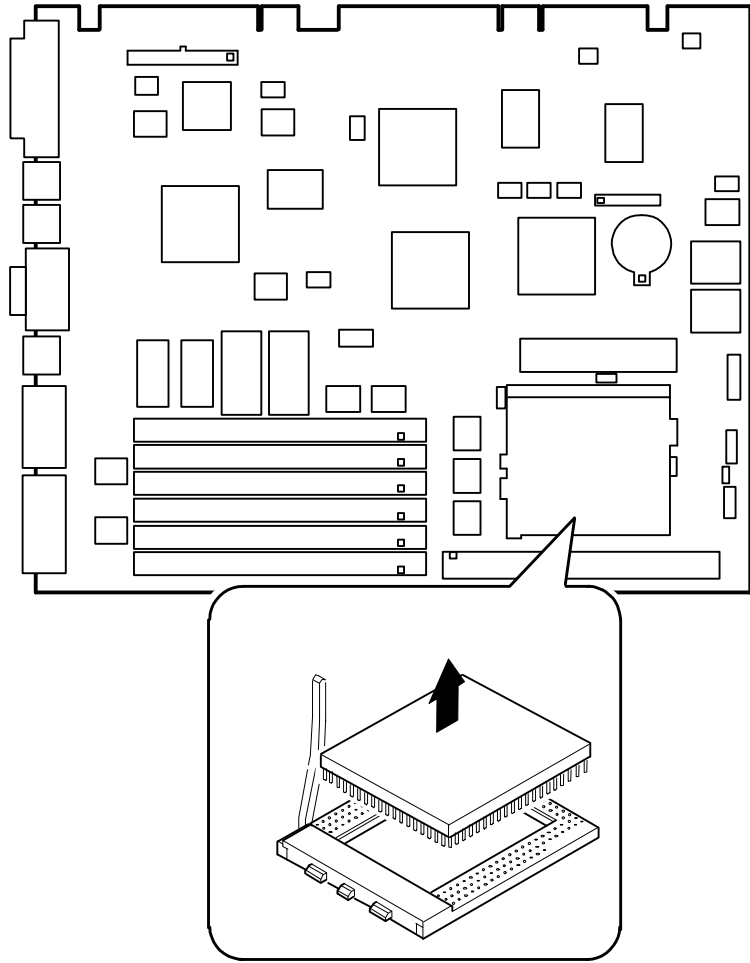

DEC00752-22

Figure 5-22. Removing the Processor Heat Sink

Removing the Voltage Regulator Module (VRM)

1. Turn off the computer, monitor, and then disconnect power from the computer.
2. Remove the outside cover.
3. Remove the main logic board.
4. Remove the VRM by pulling it straight up.

VENTURIS FX and CELEBRIS FX

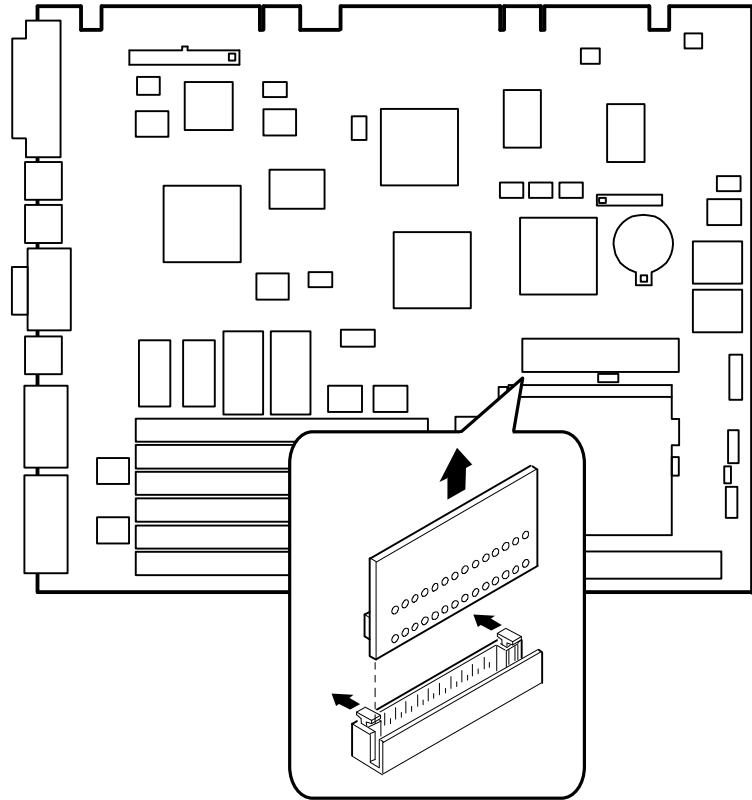

DEC00752-23

Figure 5-23. Removing the VRM

Removing the Backplane (Venturis FX and Celebris FX Low Profile)

1. Turn off the computer, monitor, and then disconnect power from the computer.
2. Remove the outside cover.
3. Disconnect all power, video, disk and diskette cables.
4. Remove any expansion boards.
5. Remove the diskette drive.
6. Remove the main logic board.
7. Remove the screws.
8. Remove the backplane.

VENTURIS FX and CELEBRIS FX

VENTURIS FX and CELEBRIS FX

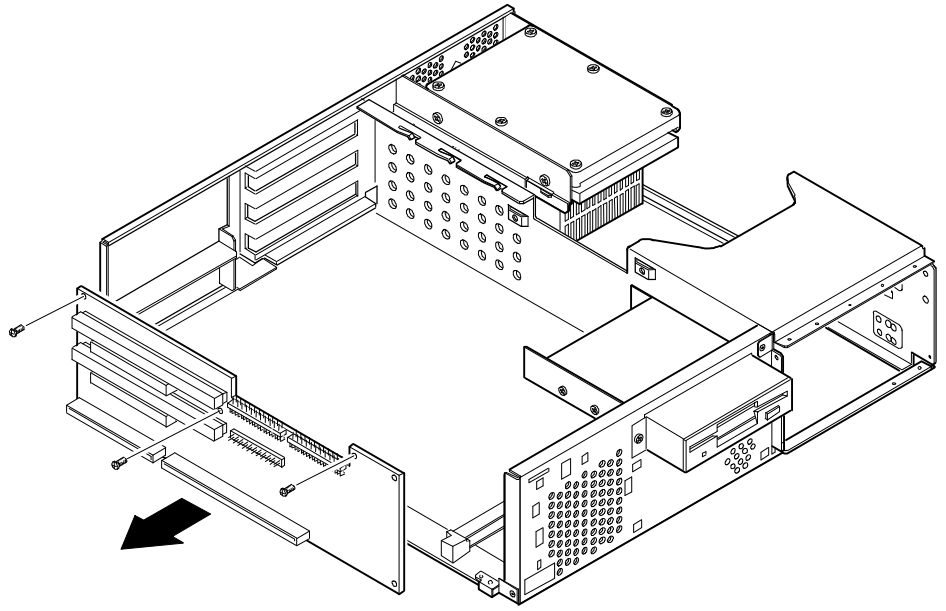

DEC0089

Figure 5-24. Removing the Backplane (Venturis FX and Celebris FX Low Profile)

Removing the Backplane (Venturis FX Short Tower)

1. Turn off the computer, monitor, and then disconnect power from the computer.
2. Remove the outside cover.
3. Remove the screw from the internal drive bay.
4. Swing the drive bay away from the chassis.
5. Remove any expansion boards.
6. Disconnect all power, video, disk and diskette cables.
7. Remove the main logic board.
8. Remove the screws at the rear holding the backplane to the chassis.
9. Remove the backplane.

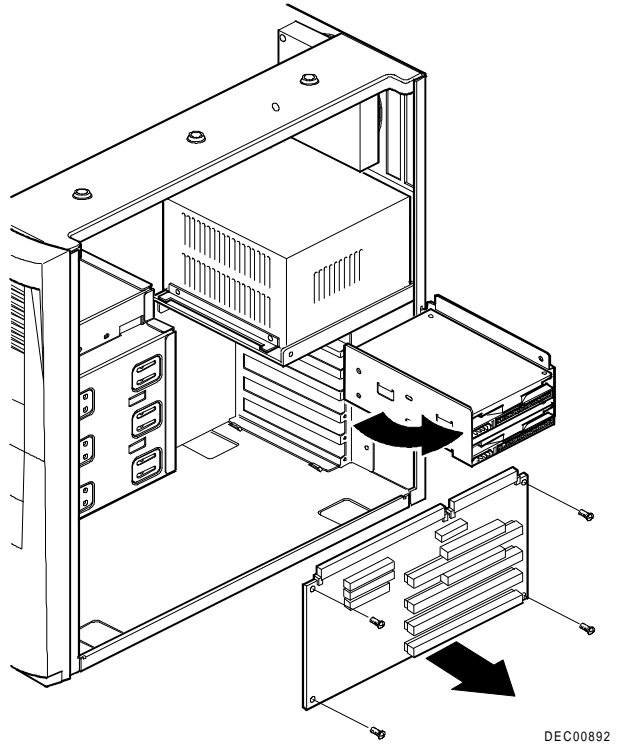

Figure 5-25. Removing the Backplane (Venturis FX Short Tower)

Removing Expansion Boards



NOTE: You do not have to remove the main logic board to remove an expansion board.

1. Turn off the computer, monitor, and then disconnect power from the computer.
2. Remove the outside cover.
3. Remove the screw.
4. Gently pull the expansion board from its socket.

VENTURIS FX and CELEBRIS FX

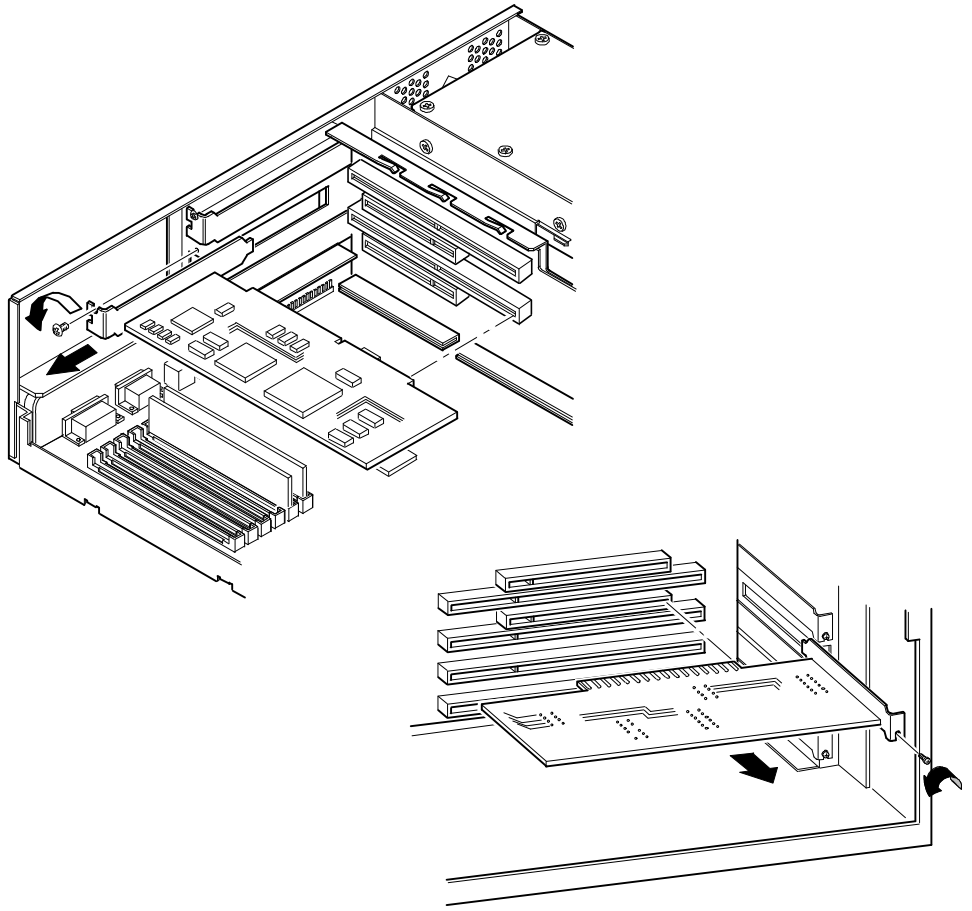

DEC00960-4

Figure 5-26. Removing Expansion Boards

Removing the Power Supply (Venturis FX and Celebris FX Low Profile)

1. Turn off the computer, monitor, and then disconnect power from the computer.
2. Remove the outside cover.
3. Remove the internal hard disk drive.

Refer to “Removing Internal 3½-Inch Device (Venturis FX and Celebris FX low profile).”

4. Disconnect the power cable from the backplane.
5. Disconnect all power cables from all devices.
6. Remove the screws.
7. Remove the power supply and bracket from the chassis.
8. Remove the bracket from the power supply.

VENTURIS FX and CELEBRIS FX

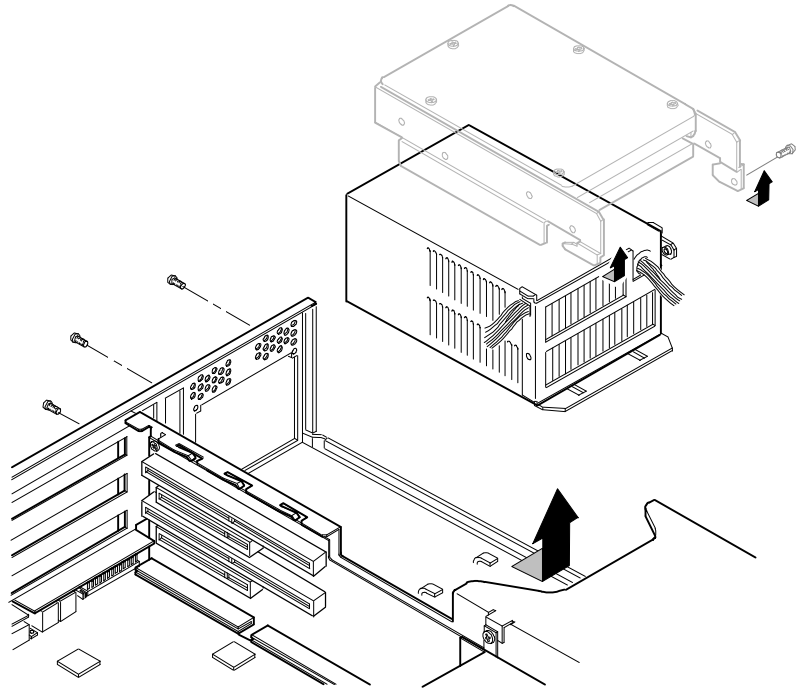

DEC00885

Figure 5-27. Removing the Power Supply (Venturis FX and Celebris FX Low Profile)

Removing the Power Supply (Venturis FX Short Tower)

1. Turn off the computer, monitor, and then disconnect power from the computer.
2. Remove the outside cover.
3. Remove the internal drive bay assembly.

Refer to “Removing Internal 3½-Inch Device (Venturis FX short tower).”

4. Disconnect the power cable from the backplane.
5. Disconnect all power cables from all devices.
6. Remove the screws from the power supply.
7. Remove the power supply.

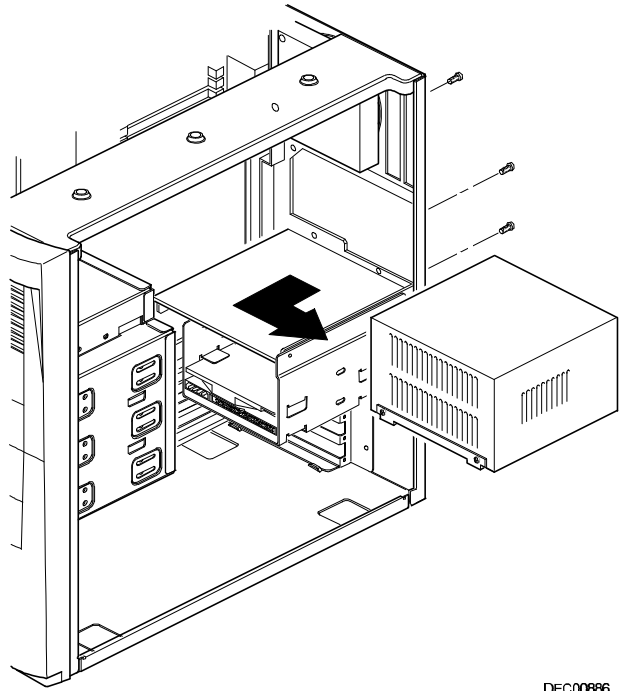

DEC00886

Figure 5-28. Removing the Power Supply (Venturis FX Short Tower)

Removing the Control Panel Assembly (Venturis FX and Celebris FX Low Profile)

1. Turn off the computer, monitor, and then disconnect power from the computer.
2. Remove the outside cover.
3. Remove the diskette drive and the bracket.

Refer to “Remove Diskette Drive (Venturis FX and Celebris FX low profile).”

4. Remove the control panel assembly with the air duct and the fan.
5. Unplug the control panel cable from the backplane.
6. If there is a fan, unplug the fan cable from the backplane.

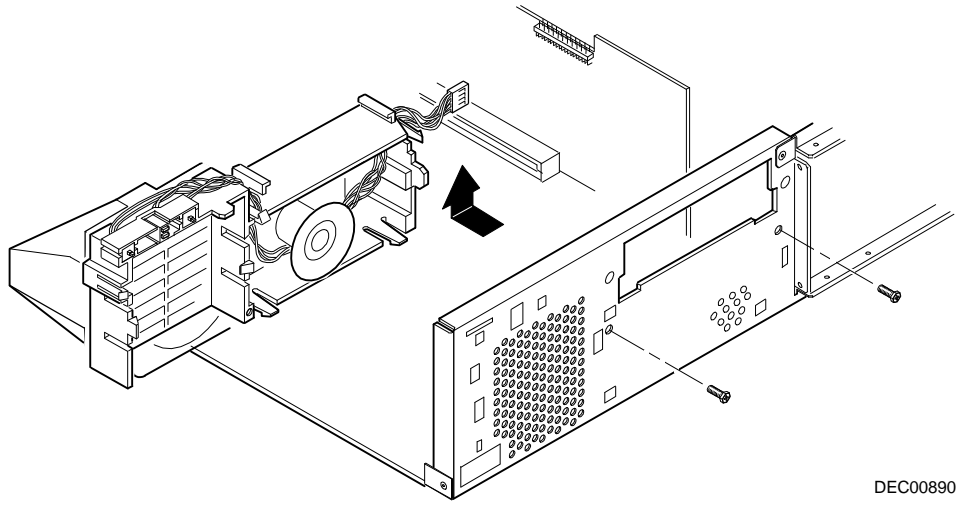

DEC00890

Figure 5-29. Removing the Control Panel Assembly (Venturis FX and Celebris FX Low Profile)

Removing the Front Air Duct (Venturis FX Short Tower)

1. Turn off the computer, monitor, and then disconnect power from the computer.
2. Remove the outside cover.
3. Remove the front air duct.

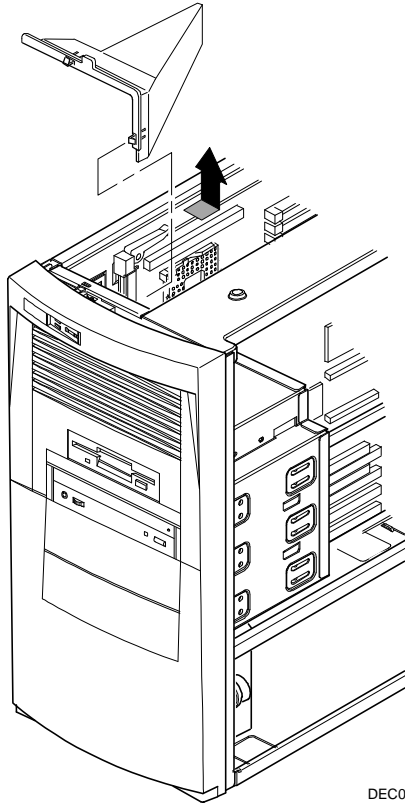

DEC01011

Figure 5-30. Removing the Front Air Duct (Venturis FX Short Tower)

Removing the Control Panel Assembly and Cable (Venturis FX Short Tower)

VENTURIS FX and CELEBRIS FX

1. Turn off the computer, monitor, and then disconnect power from the computer.
2. Remove the outside cover.
3. Remove the front air duct.
4. Remove front bezel.
5. Push in on the tabs to disengage the control panel assembly.
6. Disconnect the cables from the control panel assembly noting the following when you reconnect.
 - White and black is the reset switch.
 - White, black, and red is the power switch.
 - Red and black is hard disk drive activity LED.
 - Yellow and black is the power LED. It is on top of the hard disk drive indicator.
7. Slide the cables through the slots.

The cables and their attached switch or indicators are now inside the computer.
8. Unplug the cable connection from the backplane.
9. Rotate the speaker to remove it from the option card assembly.
10. Remove the control panel assembly cables from the computer.

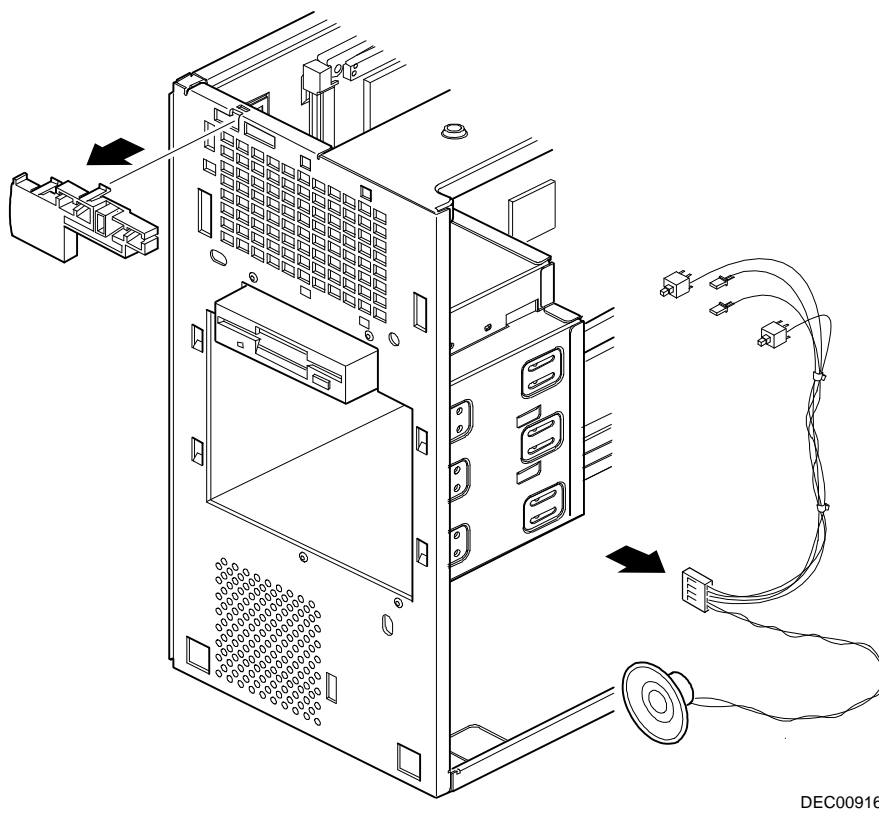

DEC00916

**Figure 5-31. Removing the Control Panel Assembly and Cable
(Venturis FX Short Tower)**

Removing the Option Card Assembly (Venturis FX Short Tower)

1. Turn off the computer, monitor, and then disconnect power from the computer.
2. Remove the outside cover.
3. Remove the option card assembly.

VENTURIS FX and CELEBRIS FX

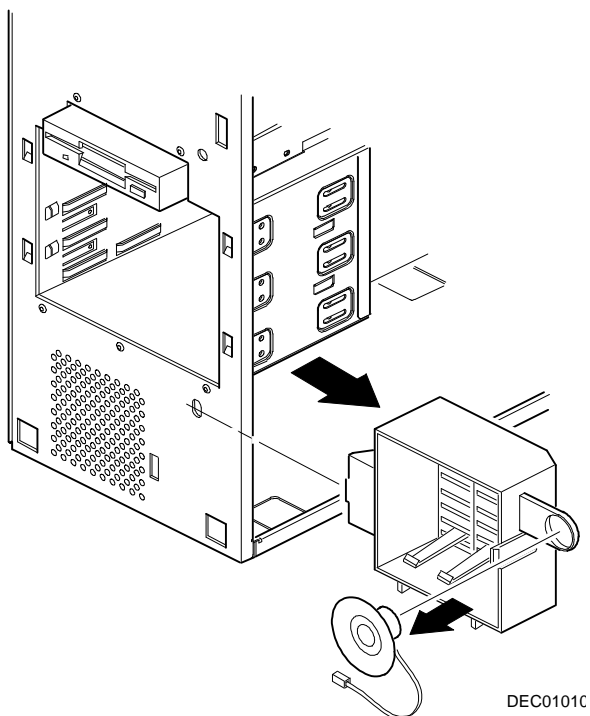

Figure 5-32. Removing the Option Card Assembly (Venturis FX Short Tower)

Removing the Wire Assembly, Headphone/Microphone (Venturis FX Short Tower)

1. Turn off the computer, monitor, and then disconnect power from the computer.
2. Remove the outside cover.
3. Remove the front bezel.
4. Push in on the tabs to disengage the control panel assembly.

The headphone and microphone connections are on a card inside the control panel assembly. This card is attached to the cable.

5. Remove the headphone and microphone card from the control panel assembly.

Push down on the headphone and microphone card to release it from the tabs and then slide the card back.

6. Unplug the other side of the cable from the backplane.
7. Slide the card through the appropriate front slot and then remove the headphone and microphone cable.

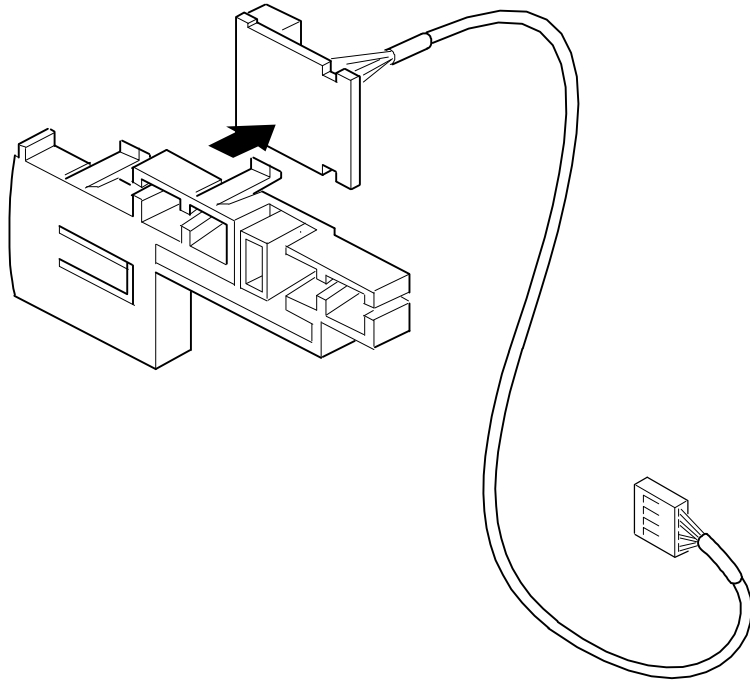

DEC00917

Figure 5-33. Removing the Wire Assembly, Headphone/Microphone (Venturis FX Short Tower)

Removing a 3½-Inch Device from Front Bay (Venturis FX and Celebris FX Low Profile)

1. Turn off the computer, monitor, and then disconnect power from the computer.
2. Remove the outside cover.
3. Disconnect all power and data cables.
4. Remove the screws holding the drive to the bay.
5. Remove the 3½-inch device, which includes the rail and the brackets.
6. Remove the rail from the device.
7. Remove the brackets from the device.

VENTURIS FX and CELEBRIS FX

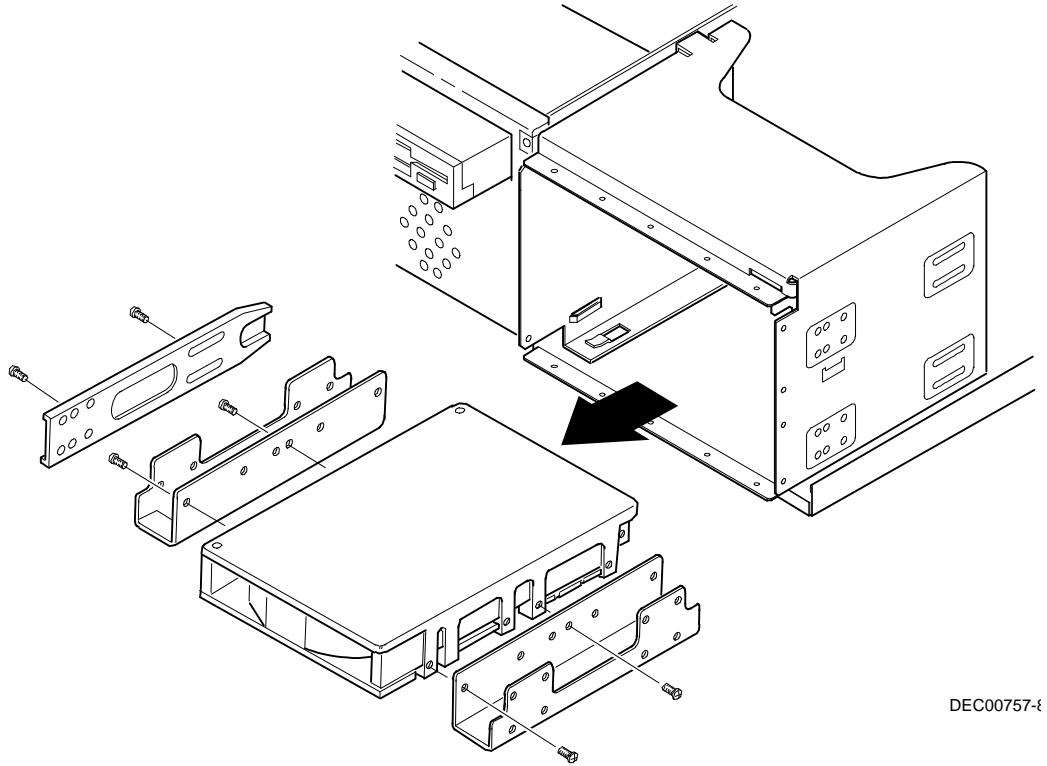

DEC00757-1

Figure 5-34. Removing a 3½-Inch Device from Front Bay (Venturis FX and Celebris FX Low Profile)

Removing a 5¼-Inch Device (Venturis FX and Celebris FX Low Profile)

1. Turn off the computer, monitor, and then disconnect power from the computer.
2. Remove the outside cover.
3. Disconnect all power and data cables.
4. Remove the screws holding the drive to the bay.
5. Remove the 5¼-inch device, which includes the rail.
6. Remove the rail from the device.

VENTURIS FX and CELEBRIS FX

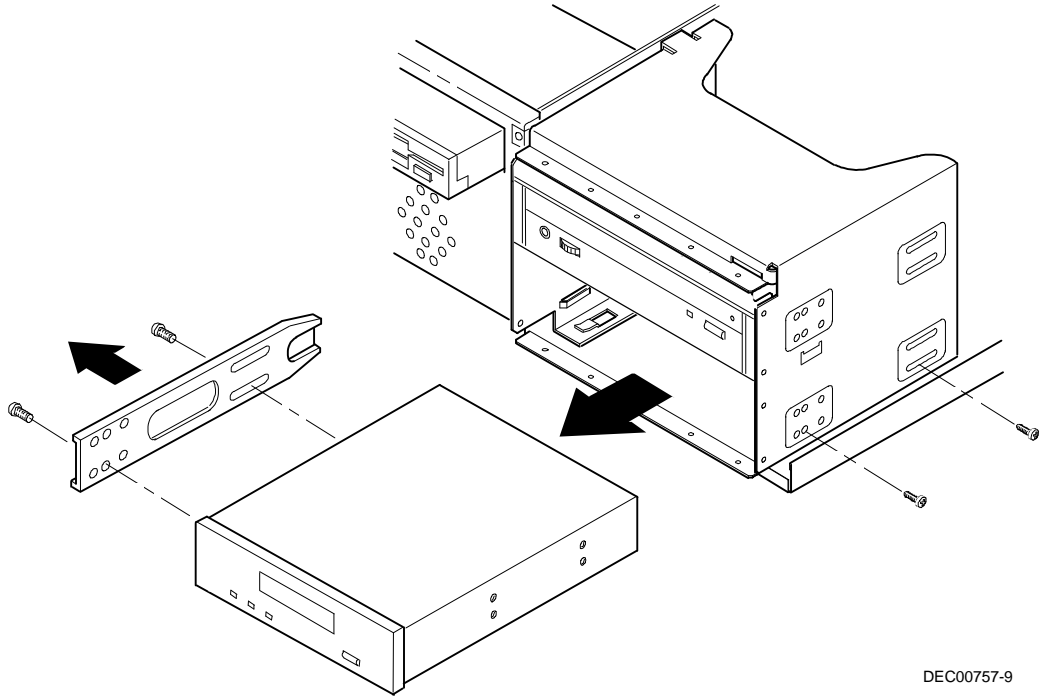

DEC00757-9

Figure 5-35. Removing a 5 1/4-Inch Device (Venturis FX and Celebris FX Low Profile)

IDE Drive Connections (Venturis FX and Celebris FX Low Profile)

Figure Legend	IDE Drive Component
A	Power supply
B	Primary IDE hard disk drive
C	Power connections
D	Primary IDE hard disk drive connections
E	Backplane IDE drive connection (primary)
F	Secondary IDE hard disk drive connections
G ⁽¹⁾	CD-ROM drive (not available on all models)
H	Backplane IDE drive connection (secondary)

⁽¹⁾ The CD-ROM drive is connected to the secondary IDE port and configured as a master drive.

VENTURIS FX and CELEBRIS FX

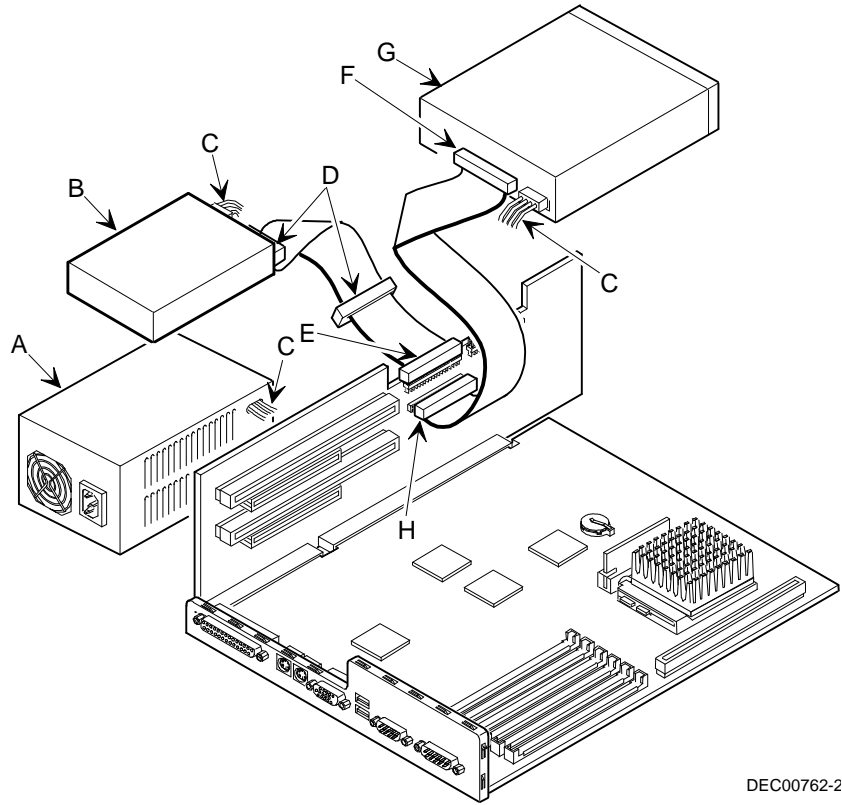

DEC00762-2

Figure 5-36. IDE Drive Connections (Venturis FX and Celebris FX Low Profile)

Removing the Internal 3½-Inch Device (Venturis FX and Celebris FX Low Profile)

1. Turn off the computer, monitor, and then disconnect power from the computer.
2. Remove the outside cover.
3. Disconnect all power and data cables from the device.
4. Remove the screw from the bracket.
5. Remove the 3½-inch device with the bracket by sliding the device forward and lifting.
6. Remove the 3½-inch device from the bracket.

VENTURIS FX and CELEBRIS FX

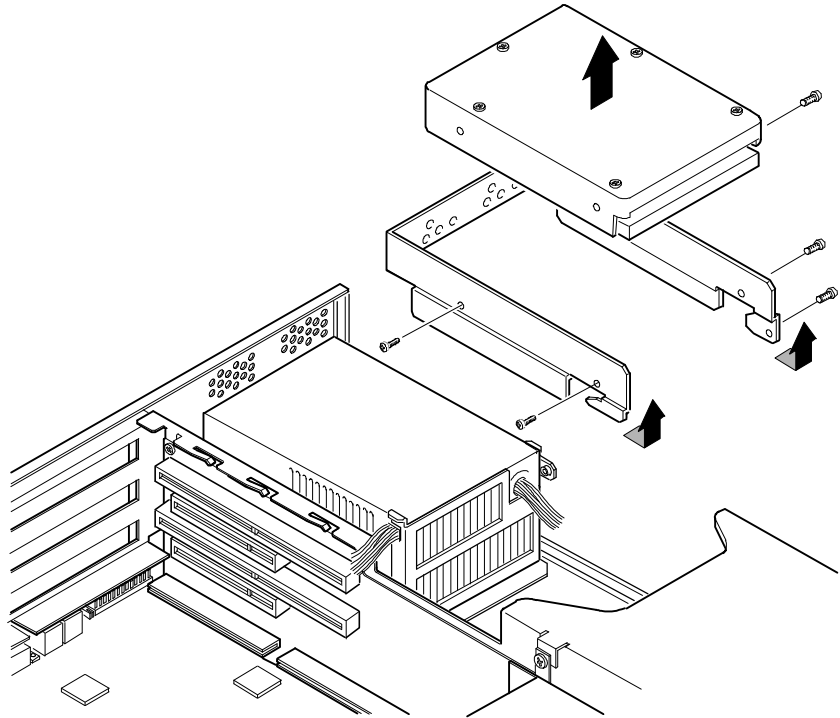

DEC00894

Figure 5-37. Removing the Internal 3 1/2-Inch Device (Venturis FX and Celebris FX Low Profile)

Removing the Diskette Drive (Venturis FX and Celebris FX Low Profile)

1. Turn off the computer, monitor, and then disconnect power from the computer.
2. Remove the outside cover.
3. Remove all power and data cables from the diskette drive.
4. Remove the screws from the front holding the drive and the bracket in the bay.
5. Remove the diskette drive with the bracket.

VENTURIS FX and CELEBRIS FX

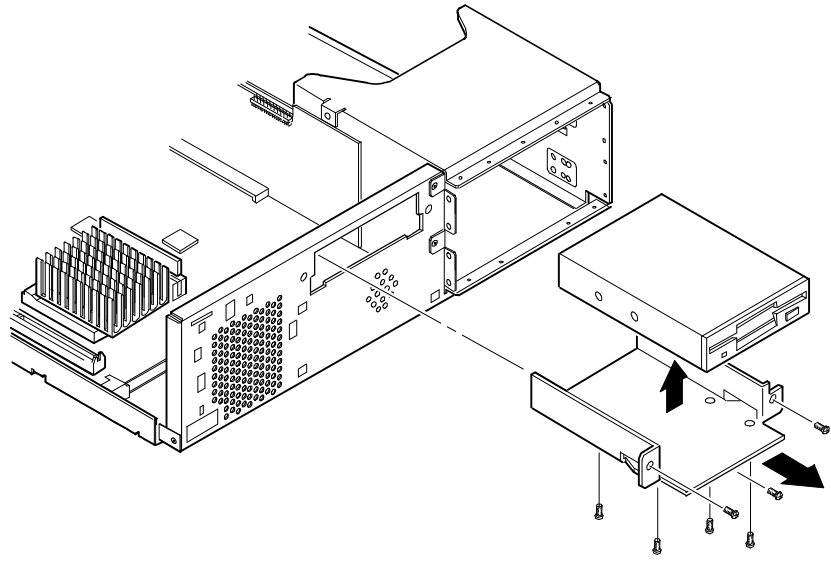

DEC00887

Figure 5-38. Removing the Diskette Drive (Venturis FX and Celebris FX Low Profile)

Diskette Drive Connections (Venturis FX and Celebris FX Low Profile)

Figure Legend	Diskette Drive Component
A	Power supply
B	Power connection
C	Diskette drive connections
D	Backplane diskette drive connection
E	Diskette drive

VENTURIS FX and CELEBRIS FX

VENTURIS FX and CELEBRIS FX

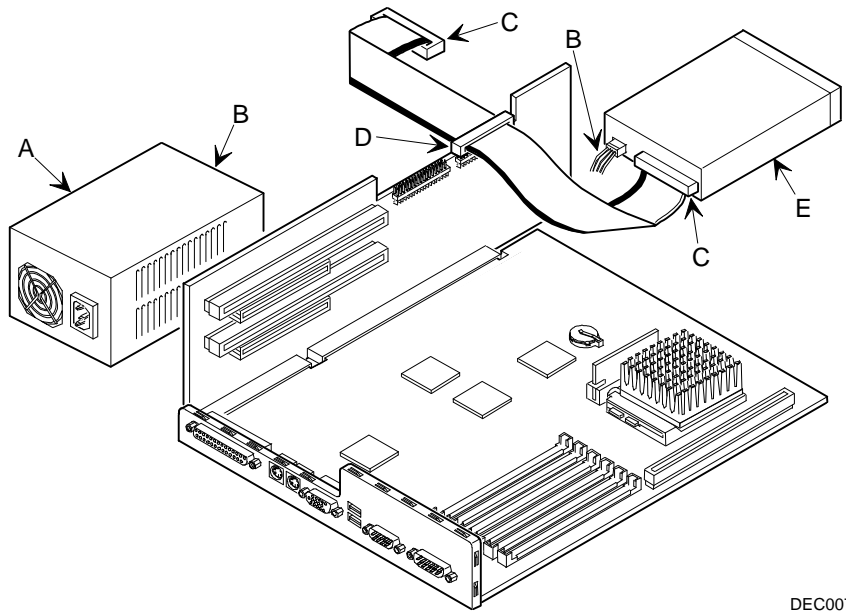

DEC0076

Figure 5-39. Diskette Drive Connections (Venturis FX and Celebris FX Low Profile)

Removing the Front Bezel (Venturis FX Short Tower)

1. Turn off the computer and monitor.
2. Disconnect all external devices, ac power, and monitor power.
3. Remove the outside cover.
4. From the top of the computer, find both tabs (one on the left and one on the right).
5. Push both tabs towards the center of the computer to release the top of the bezel.
6. Pull the top of the bezel approximately an inch away from the top of the chassis.
7. Pull up on the bezel to detach the bottom bezel mounts.

VENTURIS FX and CELEBRIS FX

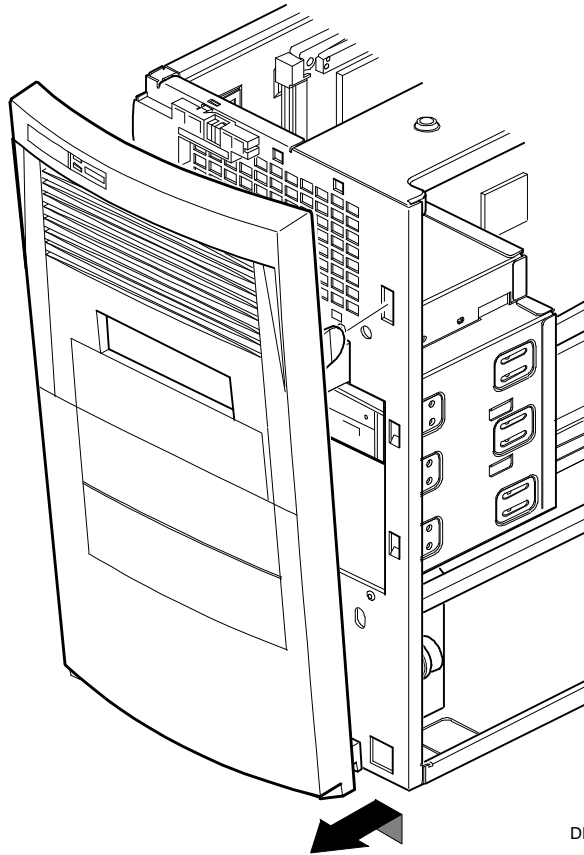

DEC00758-11

Figure 5-40. Removing the Front Bezel

Removing a 3½-Inch Device from Front Bay (Venturis FX Short Tower)

1. Turn off the computer, monitor, and then disconnect power from the computer.
2. Remove the outside cover.
3. Remove the front bezel.
4. Disconnect all power and data cables.
5. Remove the two screws holding the drive to the bay.
6. Remove the 3½-inch device, which includes the rail and the brackets.
7. Remove the rail from the device.
8. Remove the brackets from the device.

VENTURIS FX and CELEBRIS FX

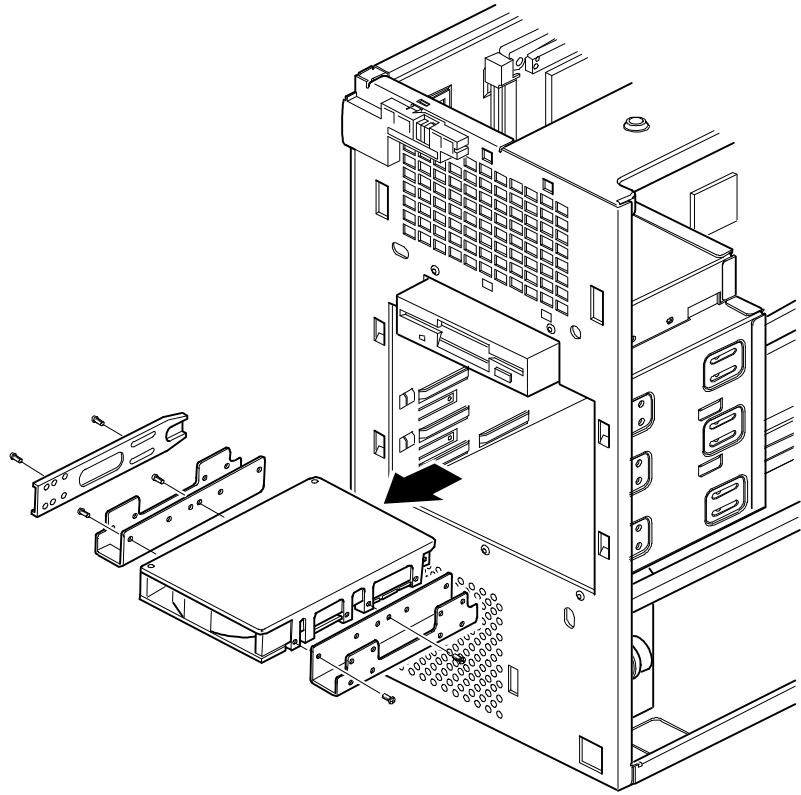

DEC00758-12

Figure 5-41. Removing a 3½-Inch Device from Front Bay (Venturis FX Short Tower)

Removing a 5¼-Inch Device (Venturis FX Short Tower)

1. Turn off the computer, monitor, and then disconnect power from the computer.
2. Remove the outside cover.
3. Remove the front bezel.
4. Disconnect all power and data cables.
5. Remove the two screws holding the drive to the bay.
6. Remove the 5¼-inch device, which includes the rail.
7. Remove the rail from the device.

VENTURIS FX and CELEBRIS FX

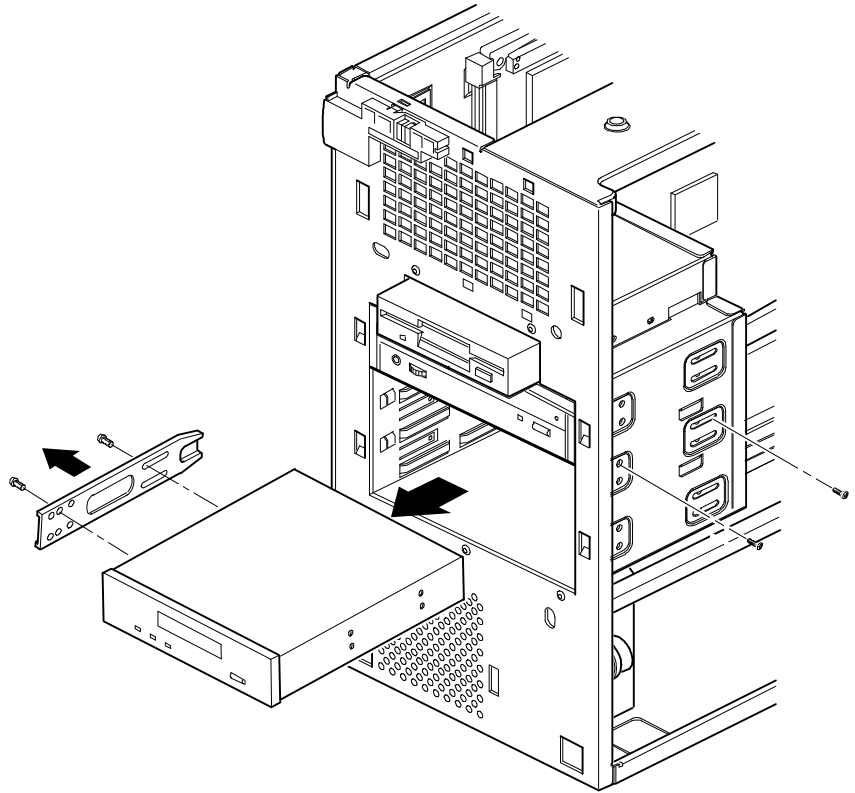

DEC00758-13

Figure 5-42. Removing a 5 1/4-Inch Device (Venturis FX Short Tower)

Removing an Internal 3½-Inch Device (Venturis FX Short Tower)

1. Turn off the computer, monitor, and then disconnect power from the computer.
2. Remove the outside cover.
3. Disconnect all power and data cables.
5. Remove the screw securing the drive bay to the chassis.
6. Swing the device bay away from the chassis.
7. Remove the screws from the drive bay.
8. Remove the 3½-inch device.

VENTURIS FX and CELEBRIS FX

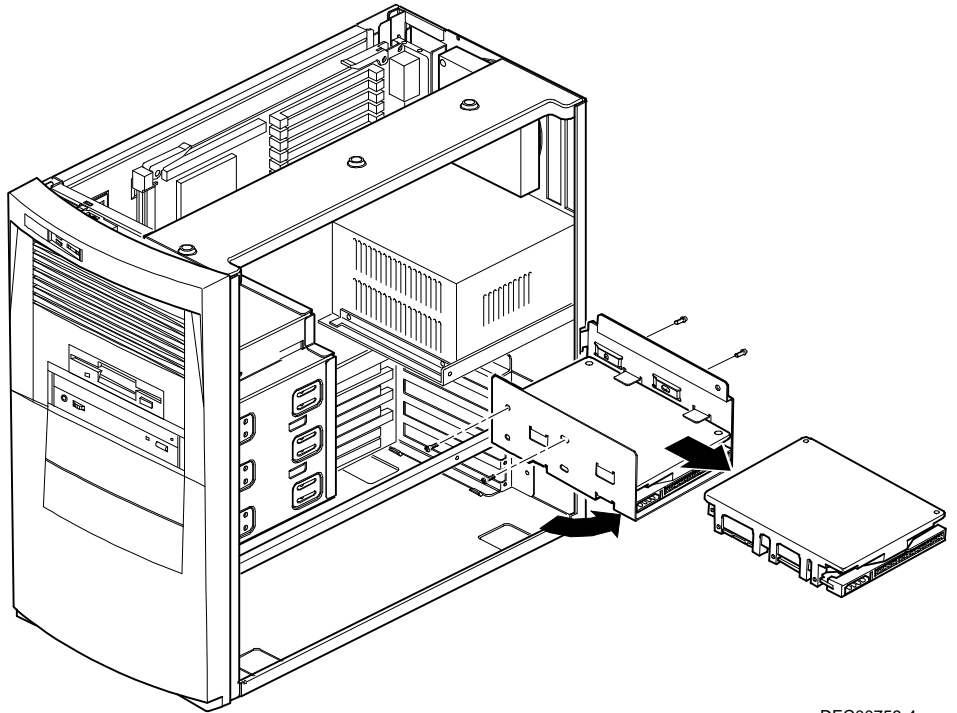

DEC00759-4

Figure 5-43. Removing an Internal 3½-Inch Device (Venturis FX Short Tower)

IDE Drive Connections (Venturis FX Short Tower)

Figure Legend	IDE Drive Component
A	Backplane IDE drive connection (primary)
B	Power connections
C	Power supply
D	Primary IDE hard disk drive
E	Primary IDE hard disk drive connections
F	Backplane IDE drive connection (secondary)
G	Secondary IDE hard disk drive connections
H ⁽¹⁾	CD-ROM drive (not available on all models)

⁽¹⁾ The CD-ROM drive is connected to the secondary IDE port and configured as a master drive.

VENTURIS FX and CELEBRIS FX

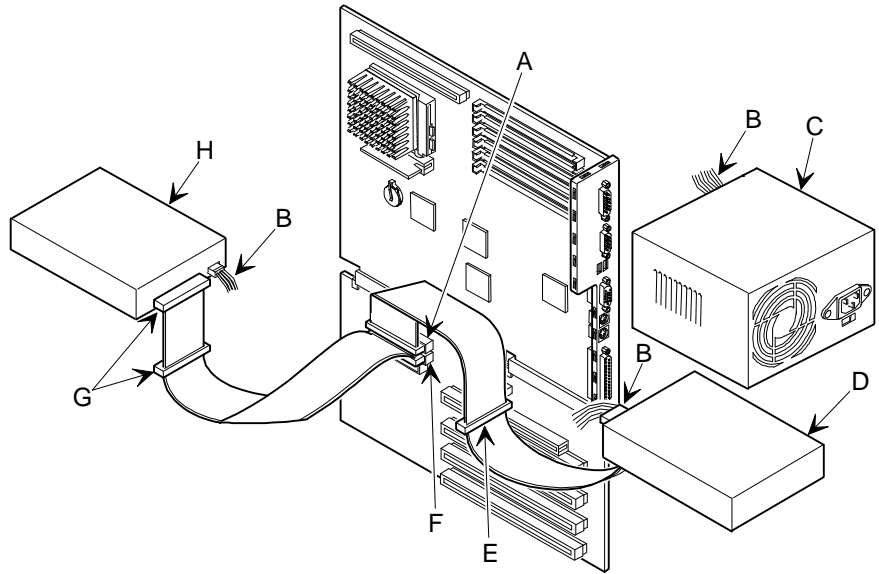

DEC00961-2

Figure 5-44. IDE Drive Connections (Venturis FX Short Tower)

Removing the Diskette Drive (Venturis FX Short Tower)

1. Turn off the computer, monitor, and then disconnect power from the computer.
2. Remove the outside cover.
3. Remove the front bezel.
4. Remove all power and data cables from the diskette drive.
5. Remove the screws.
6. Remove the diskette drive.

VENTURIS FX and CELEBRIS FX

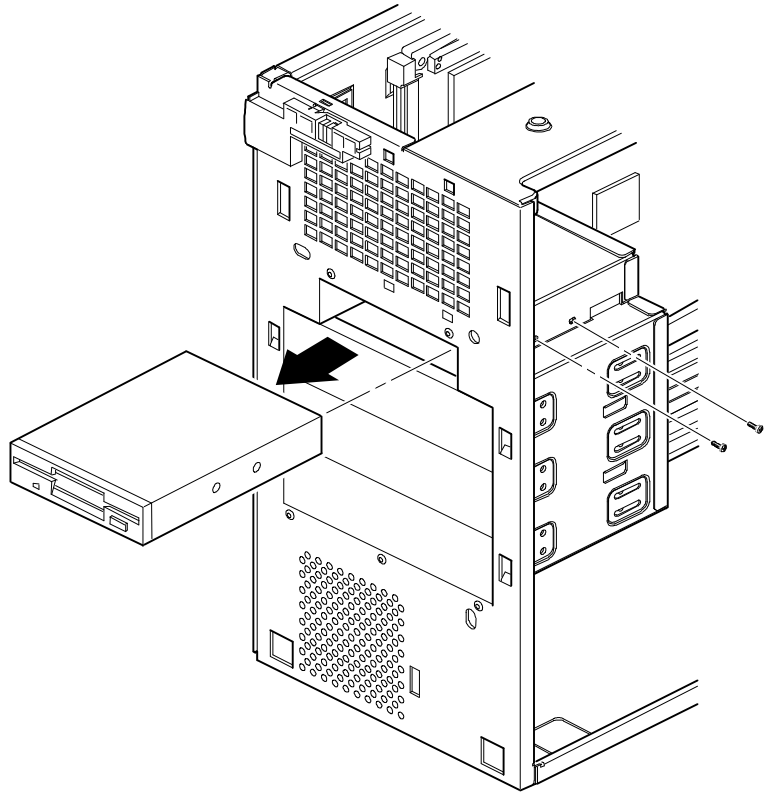

DEC00888-2

Figure 5-45. Removing the Diskette Drive (Venturis FX Short Tower)

Diskette Drive Connections (Venturis FX Short Tower)

Figure Legend	Diskette Drive Component
A	Power connection
B	Diskette drive
C	Diskette drive connections
D	Backplane diskette drive connection
E	Power supply

VENTURIS FX and CELEBRIS FX

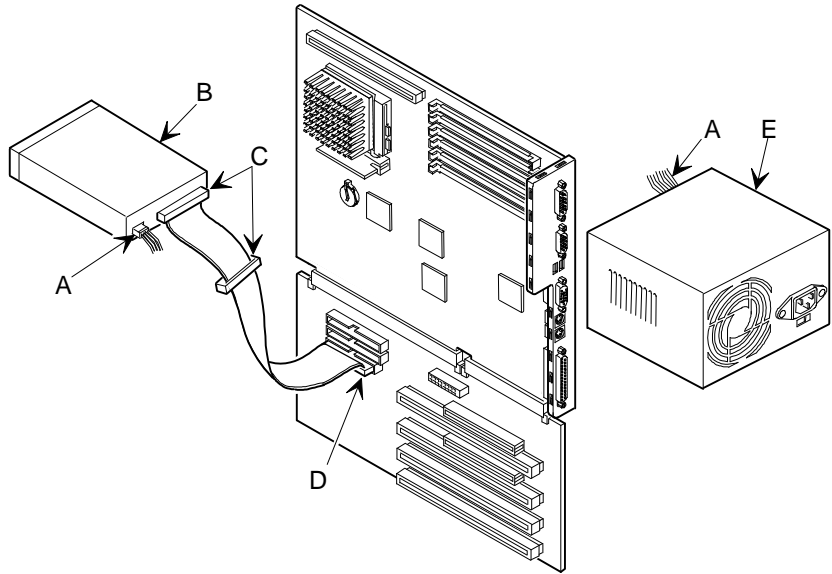

DEC00763-2

Figure 5-46. Diskette Drive Connections (Venturis FX Short Tower)

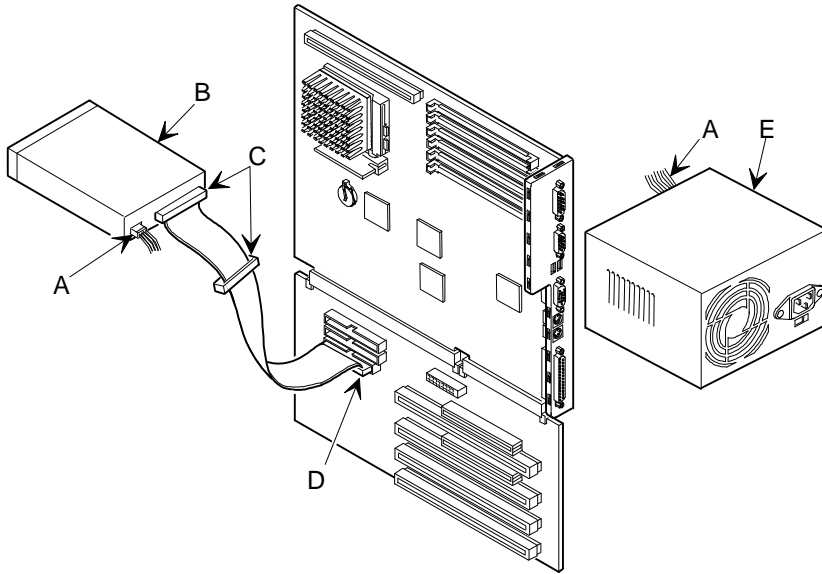

DEC00763-2

Figure 5-46. Diskette Drive Connections (Venturis FX Short Tower)

VENTURIS FX and CELEBRIS FX

Introduction

This chapter provides a series of tables listing mapping and address information related to computer memory and various main logic board devices (keyboard controller, interrupt controller, DMA controller, etc.).

Your computer's memory and address locations are allocated at the factory to operate within a standard PC environment. However, due to the number of optional devices and/or expansion boards that are available, sometimes memory and address locations need to be changed. For example, some network expansion boards require a specific memory location. If that location is already allocated, a memory conflict results and the expansion board will not operate as expected. Note that some memory, I/O and interrupt locations can be changed using the BIOS Setup utility.



CAUTION: Before changing any memory or address location, refer to the documentation supplied with the optional device, expansion board, or software application and make sure adequate information is available. If not, contact the option or software manufacturer for further information.

CPU Memory Address Map (Full Range)

Range	Function	Size
0 to 9FFFFh	Base memory	640 KB
A0000h to BFFFFh	Video RAM	128 KB
C0000h to C7FFFh	VGA BIOS	32 KB
C8000h to DFFFFh	BIOS extension ROM (AT bus used)	96 KB
E0000h to FFFFFh	PnP BIOS/APM BIOS	128 KB
100000h to BFFFFFFh	Extended memory	191 MB

I/O Address Map

Range (hexadecimal)	Function
000 - 00F	DMA controller one
020 - 021	Interrupt controller one
022	Index register (Sis5513)
023	Data register (Sis5513)
040 - 043	Interval timer
060 - 06F	Keyboard controller
070 - 07F	Real-Time Clock (RTC), NMI
080 - 08F	DMA page register
0A0 - 0A1	Interrupt controller two
0C0 - 0CF	DMA controller two
0F0	Clear math co-processor busy
0F1	Reset math co-processor
0F8 - 0FF	Math co-processor
170 - 17F	Secondary IDE controller
1F0 - 1F7	Primary IDE controller
201	Joystick
220 - 22F	Audio
278 - 27A	LPT2
2E8 - 2EF	COM4

continued

Range (hexadecimal)	Function
2F8 - 2FF	COM2
300 - 301	MIDI MPU (Venturis FXsm only)
310 - 311	
320 - 321	
330 - 331 ⁽¹⁾	
378 - 37A	LPT1
388 - 38B	Audio, FM music synthesizer
3BC - 3BE	LPT3
3E8 - 3EF	COM3
3F0 - 3F7	Diskette (floppy disk) controller
3F6 - 3F7	Primary/secondary IDE controller (alt status, device address)
3F8 - 3FF	COM1
4D0	Edge/level control register - INTCNTRL1
4D1	Edge/level control register - INTCNTRL2
CF8 - CFF	PCI configure space control register
CC00	Programming chip select

⁽¹⁾ These are the possible ranges. If the device is Plug and Play and you are using it with a Plug and Play operating system, such Windows 95, Plug and Play will select the correct address. Otherwise, use the ICU to determine an available I/O address.

Computer Interrupt Levels

Interrupt Number	Interrupt Source
IRQ0	Timer tick
IRQ1	Keyboard controller
IRQ2	Cascade interrupt
IRQ3	COM2, COM4, if enabled
IRQ4	COM1, COM3, if enabled
IRQ5	Audio, if enabled
IRQ6	Diskette (floppy disk) drive, if enabled
IRQ7	LPT1, LPT3, if enabled
IRQ8	Real Time Clock (RTC)
IRQ9	Video
IRQ10	Reserved
IRQ11	Network
IRQ12	Mouse interrupt, if enabled
IRQ13	Math co-processor
IRQ14	IDE primary, if enabled
IRQ15	IDE secondary, if enabled

DMA Channel Assignment

Channel	Controller	Function
0	1	Refresh
1	1	Audio or ECP
2	1	Diskette (floppy disk) controller, if enabled
3	1	Not used
4	2	Cascade DMA
5	2	ECP or not used
6	2	Not used
7	2	Not used

Service Notes **A**

VENTURIS FX and CELEBRIS FX

VENTURIS FX and CELEBRIS FX

VENTURIS FX and CELEBRIS FX



BAAWW-SM. A01

Printed in U.S.A.



Printed on
Recycled Paper.