

# Digital SNA Data Transfer Facility for OpenVMS

---

## Problem Solving and Messages

Part Number: AA-JR79F-TE

**May 1996**

This manual describes debugging procedures and problem solving techniques for the Digital SNA Data Transfer Facility (DTF) software. The manual also includes a description of all error messages generated by the DTF file transfer interfaces.

**Revision/Update Information:** This is a revised manual.

**Operating System and Version:** OpenVMS VAX Versions 6.1, 6.2, or 7.0  
OpenVMS Alpha Versions 6.1, 6.2, or 7.0  
RSX-11M/M-PLUS Version 4.2(M)/Version  
4.0(M-PLUS) or later  
MS-DOS Version 3.0 or later  
OS/2 Version 1.2 or later  
MVS/SP, MVS/XA, MVS/ESA  
VM/SP, VM/XA  
See the SPD for the latest operating  
system version.

**Software Version:** Digital SNA Data Transfer Facility for  
OpenVMS, Version 3.2

---

**May 1996**

The information in this document is subject to change without notice and should not be construed as a commitment by Digital Equipment Corporation or EDS. Digital Equipment Corporation or EDS assumes no responsibility for any errors that may appear in this document.

The software described in this document is furnished under a license and may be used or copied only in accordance with the terms of such license.

No responsibility is assumed for the use or reliability of software on equipment that is not supplied by Digital Equipment Corporation or its affiliated companies.

Digital conducts its business in a manner that conserves the environment.

Restricted Rights: Use, duplication, or disclosure by the U.S. Government is subject to restrictions as set forth in subparagraph (c)(1)(ii) of the Rights in Technical Data and Computer Software clause at DFARS 252.227-7013.

Copyright © 1988, 1996 Digital Equipment Corporation, EDS Defense Limited  
All Rights Reserved.

The following are trademarks of Digital Equipment Corporation: Alpha, DEC, DEC/CMS, DEC/MSS, DECnet, DECSYSTEM-10, DECSYSTEM-20, DECUS, DECwriter, DIBOL, EduSystem, IAS, MASSBUS, OpenVMS, PDP, PDT, RSTS, RSX, UNIBUS, VAX, VAXcluster, VMS, VT, and the Digital logo.

IBM, RACF, and OS/2 are registered trademarks of International Business Machines Corporation.

CA-ACF2 and CA-TOP SECRET are registered trademarks of Computer Associates International, Inc.

MS-DOS is a registered trademark of Microsoft Corporation.

---

# Contents

<b>Preface</b> .....	vii
<b>1 How the DTF Product Works</b>	
1.1 The DTF for IBM Components .....	1-2
1.2 The OpenVMS/DTF Components .....	1-2
1.3 DTF for IBM Software Initialization .....	1-4
1.4 OpenVMS/DTF Software Initialization .....	1-4
1.5 Nonrecoverable File Transfers Initiated from an IBM System to a DECnet System .....	1-7
1.6 Recoverable File Transfers Initiated from an IBM System to a DECnet System .....	1-9
1.7 File Transfers Between Two IBM Systems .....	1-12
1.8 Nonrecoverable File Transfers Initiated from a DECnet Node ...	1-15
1.9 Recoverable File Transfers Initiated from a DECnet Node .....	1-17
<b>2 Isolating DTF Software Problems</b>	
2.1 Usage Problems .....	2-2
2.1.1 Isolating DTF for IBM Usage Errors .....	2-2
2.1.2 Isolating OpenVMS/DTF Usage Errors .....	2-3
2.2 Installation Errors .....	2-5
2.2.1 Isolating DTF for IBM Installation Errors .....	2-5
2.2.2 Isolating OpenVMS/DTF Installation Errors .....	2-6
2.3 Software Errors .....	2-8
2.3.1 Isolating and Reporting DTF for IBM Software Errors .....	2-8
2.3.2 Isolating and Reporting OpenVMS/DTF Software Errors .....	2-8

### 3 Gathering Information on DTF for IBM Problems

3.1	Examining the SYSPRINT File .....	3-2
3.2	Examining Abend Dumps .....	3-3
3.3	Examining the Internal Trace Table .....	3-3
3.4	Using the External Trace .....	3-4
3.4.1	External Tracing for MVS .....	3-4
3.4.2	External Tracing in VM .....	3-4
3.5	Using DTF Component DEBUG Mode .....	3-6
3.6	Examining IDCAMS Output .....	3-7
3.6.1	The IDCAMOUT File (MVS Only) .....	3-8
3.6.2	The VSAMLOG Option (MVS) .....	3-8
3.6.3	The VSAMLOG Option (VM) .....	3-9

### 4 Using the DTF Console

4.1	The DTF Console Interfaces .....	4-1
4.1.1	The MVS Node Manager Console Interface .....	4-1
4.1.2	The VM Network Manager Console Interface .....	4-2
4.1.3	The VM Node Manager Console Interface .....	4-2
4.2	DTF Console Commands .....	4-3
4.2.1	INQUIRE .....	4-3
4.2.2	SET .....	4-4
4.2.3	CLOSE .....	4-7

### 5 Gathering Information on OpenVMS/DTF Problems

5.1	Using the SNALOG_MASK Facility .....	5-1
5.1.1	Defining the SNALOG_MASK Logical .....	5-1
5.1.2	Directing the SNALOG_MASK Trace Output .....	5-4
5.1.3	Using SNALOG_MASK When Submitting SPRs .....	5-4
5.2	Using the SNATRACE Facility .....	5-4
5.3	Using the NETTRACE Facility .....	5-5
5.4	Using the CTF Facility .....	5-5

### A DTF for IBM Messages

A.1	Messages .....	A-2
-----	----------------	-----

## B DTF for IBM Return Codes

B.1	DTF Initialization Return Codes . . . . .	B-1
B.2	DTF Operation Error Return Codes . . . . .	B-2
B.3	DTF Command Processor Return Codes . . . . .	B-3

## C Primary OpenVMS/DTF Messages

## D Translating the OpenVMS/DTF Secondary Status Codes

## E OpenVMS/DTF Messages

E.1	OpenVMS/DTF Messages . . . . .	E-2
E.2	DTF for IBM Messages from MVS Systems . . . . .	E-45

## Index

## Figures

1-1	Steps in an IBM-Initiated Nonrecoverable File Transfer to a DECnet Node . . . . .	1-6
1-2	Steps in an IBM-Initiated Recoverable File Transfer to a DECnet Node . . . . .	1-8
1-3	Steps in an IBM-Initiated File Transfer to a Different IBM System . . . . .	1-11
1-4	Steps in a DECnet-Initiated Nonrecoverable File Transfer . . . . .	1-14
1-5	Steps in a DECnet-Initiated Recoverable File Transfer . . . . .	1-16

## Tables

2-1	IBM-Specific Status Codes . . . . .	2-4
3-1	Information Collection Tools for Common Software Errors . . . . .	3-1
3-2	SNAPDUMP ID Summary . . . . .	3-6
4-1	DTF Console Commands . . . . .	4-3
4-2	PROXY Settings and Descriptions (MVS Only) . . . . .	4-6
5-1	SNALOG_MASK Bit Definitions . . . . .	5-2
B-1	DTF Initialization Return Codes . . . . .	B-2
B-2	Operation Error Return Codes . . . . .	B-2

B-3	Suggested Problem Determination Steps .....	B-3
B-4	Return Codes for DTF Command Processor Batch Jobs .....	B-3
D-1	Numerical Secondary Status Codes .....	D-2

---

## Preface

The Digital SNA Data Transfer Facility (DTF) software is a Digital Equipment Corporation product that allows you to transfer files between IBM MVS and VM systems in an SNA network and systems in a Digital DECnet network. To use the DTF access routine, you must first install the appropriate versions of the software and hardware that you plan to use. Refer to the Software Product Description (SPD) for this information.

The DTF access routine consists of two major parts: the IBM-resident software (DTF for IBM software) and the Digital-resident software (OpenVMS/DTF). The IBM-resident software can reside on a VM or MVS system.

### Manual Objective

This manual provides information required to help solve problems that might arise when using the DTF software.

### Intended Audience

The Data Transfer Facility product involves cooperating software on an IBM host (referred to as DTF for IBM software) and software in a DECnet network (OpenVMS/DTF). Therefore, solving Data Transfer Facility (DTF) software problems is a cooperative effort between the OpenVMS system manager and the IBM system programmer. Both people must be aware of problems as they occur, convey the information to their counterpart at the other system, and often work on both systems to solve the problem.

The IBM system programmer is responsible for most of the IBM problem solving. The OpenVMS system manager is responsible for problem solving on a DECnet node or TCP/IP host and can use some of the DTF for IBM problem solving tools without intervention by the IBM system programmer. Some problems, however, require involvement of the IBM system programmer.

This manual can be used by both IBM system programmers and OpenVMS system managers to assist in their effort to solve and report any problems with the DTF software.

## Manual Structure

This document contains the following five chapters and five appendixes:

Chapter 1	Explains how the DTF software transfers files.
Chapter 2	Explains how to perform problem isolating procedures for the DTF for IBM software.
Chapter 3	Explains how to gather problem-solving information on IBM systems.
Chapter 4	Describes the DTF for IBM console commands.
Chapter 5	Explains how to gather problem-solving information on OpenVMS systems.
Appendix A	Describes the DTF for IBM messages and suggested user actions.
Appendix B	Describes the DTF for IBM return codes.
Appendix C	Describes the primary file request messages unique to OpenVMS/DTF.
Appendix D	Provides a table to translate OpenVMS/DTF secondary-level numeric message codes to their alphabetic equivalent.
Appendix E	Describes the OpenVMS/DTF secondary messages and suggested user actions. This appendix also includes the messages for the TRANSFER/DTF utility.

The postage-prepaid Reader's Comments form on the last page of this document requests the user's critical evaluation to assist us in preparing future documentation.

## Associated Documents

The Digital SNA Data Transfer Facility software documentation consists of the following manuals:

- *Digital SNA Data Transfer Facility for OpenVMS Installation*
- *Digital SNA Data Transfer Facility for OpenVMS Management*
- *Digital SNA Data Transfer Facility for OpenVMS Problem Solving and Messages*
- *Digital SNA Data Transfer Facility for OpenVMS Use*

You should have the following Digital documents available for reference when you use the Digital SNA Data Transfer Facility software:

- *Common Data Dictionary Summary Description*
- *Common Data Dictionary User's Guide*



- *Common Data Dictionary Utilities Reference*
- *Common Data Dictionary Data Definition Language Reference*
- *Digital SNA Domain Gateway Installation*
- *Digital SNA Domain Gateway Management*
- *Digital SNA Domain Gateway Guide to IBM Resource Definition*
- *DECnet SNA Gateway Problem Determination Guide*
- *DECnet SNA Gateway-CT Installation*
- *DECnet SNA Gateway-CT Problem Solving (OpenVMS & ULTRIX)*
- *DECnet SNA Gateway-CT Management (OpenVMS)*
- *DECnet SNA Gateway-CT Guide to IBM Parameters*
- *DECnet SNA Gateway-ST Installation*
- *DECnet SNA Gateway-ST Problem Solving (OpenVMS)*
- *DECnet SNA Gateway-ST Guide to IBM Parameters*
- *DECnet SNA Gateway Management for OpenVMS*
- *Digital Peer Server Installation and Configuration*
- *Digital Peer Server Management*
- *Digital Peer Server Network Control Language Reference*
- *Digital Peer Server Guide to IBM Resource Definition*
- *OpenVMS SNA Installation*
- *OpenVMS SNA Problem Solving*
- *OpenVMS SNA Guide to IBM Parameters*
- *OpenVMS SNA Management*
- *OpenVMS SNA Problem Determination Guide*

OpenVMS client users may also find the following Digital OpenVMS manuals to be helpful:

- *OpenVMS User's Manual*
- *OpenVMS Record Management Utilities Reference Manual*
- *DEC DATATRIEVE User's Guide*
- *OpenVMS DCL Dictionary*

- *OpenVMS DCL Concepts Manual*
- *Guide to OpenVMS File Applications*

Digital UNIX client users may also find the following DECnet/OSI for Digital UNIX manual helpful:

- *DECnet/OSI for Digital UNIX Introductory User's Guide*

ULTRIX client users may also find the following Digital DECnet-ULTRIX manual to be helpful:

- *DECnet-ULTRIX Use*

RSX-11M/M-PLUS client users may also find the following Digital DECnet-RSX manual to be helpful:

- *DECnet-RSX Guide to User Utilities*

DOS client users may also find the following PATHWORKS for DOS manual to be helpful:

- *PATHWORKS for DOS DECnet User's Guide*

OS/2 client users may also find the following PATHWORKS for OS/2 manual to be helpful:

- *PATHWORKS for OS/2 Utilities Guide*

IBM client users may also find the following IBM manuals to be helpful:

- *JCL Reference*
- *CMS Primer*
- *IBM Access Method Services*

The following IBM manuals provide additional reference information that could be helpful in problem determination:

- *DFP: Access Method Services Reference*
- *IBM VTAM Customization*
- *MVS JCL Reference Manual*
- *MVS Service Aids Manual*
- *MVS System Commands*
- *MVS System Messages*
- *VTAM Operator Commands*
- *VM Planning and Reference*

- *VM/SP6 Connectivity, Planning, and Administration*
- *VM/SP5 TSAF*

## Abbreviations and Acronyms

The following acronyms are used throughout this manual:

APPLID	Application ID
CMS	Conversational Monitor System
DFP	Data Facility Product
DTF	Digital SNA Data Transfer Facility access routine
GTF	Generalized trace facility
ISPF	Interactive System Productivity Facility
JCL	Job Control Language
RMS	Record Management Services
RWA	Resource work area
SNA	IBM's Systems Network Architecture
SVC	Supervisor call
TSO	Time Sharing Option
OpenVMS/DTF	Digital-resident Data Transfer Facility software
VSAM	Virtual Storage Access Method
VTAM	Virtual Telecommunications Access Method

## Graphic Conventions

The following conventions are used throughout this manual:

UPPERCASE	Uppercase letters in a command represent text that you must enter as shown.
<i>lowercase italics</i>	Lowercase italicized items in a command represent variables for which you must substitute an actual value.
[ ]	In command syntax, square brackets enclose optional parts of the command. Do not type the brackets when you enter the command.
{ }	In command syntax, braces indicate that you must choose one of the options enclosed. Do not type the braces when you enter the command.
<span style="border: 1px solid black; padding: 2px;">Enter</span>	This symbol represents the ENTER key. Unless otherwise stated, end every command line by pressing the ENTER key.

**MVS**

This symbol indicates a section or qualifier that applies only to the MVS operating system.

**VM**

This symbol indicates a section or qualifier that applies only to the VM operating system.

# 1

---

## How the DTF Product Works

The Data Transfer Facility product involves cooperating software on an IBM host (referred to in this manual as DTF for IBM) and software in a DECnet or TCP/IP network (OpenVMS/DTF). Therefore, solving Data Transfer Facility (DTF) software problems is a cooperative effort between the OpenVMS system manager and the IBM system programmer. Both people must be aware of problems as they occur, convey the information to their counterpart at the other system, and often work on both systems to solve the problem.

The IBM system programmer is responsible for most problem resolution on an IBM system. The OpenVMS system manager is responsible for problem resolution on a DECnet node or TCP/IP host and can use some of the DTF for IBM problem resolution tools without intervention by the IBM system programmer. Some problems, however, require the involvement of the IBM system programmer.

The material in this chapter should assist you in your effort to solve and report any problems with the DTF software. The chapter describes how DTF is intended to work for all possible combinations of file transfers.

It is easier to detect and solve problems with the DTF software if you understand what DTF components are involved and how DTF works. This chapter describes each component and explains what occurs during the following DTF file transfers.

- Nonrecoverable file transfers initiated from an IBM system to a DECnet system.
- Recoverable file transfers initiated from an IBM system to a DECnet system.
- File transfers initiated from an IBM system to another IBM system.
- File transfers initiated from a DECnet node.

## 1.1 The DTF for IBM Components

The DTF for IBM software consists of four logical components:

- The **DTF command processor** parses DTF commands entered on the IBM system and sends requests to the Network Manager.
- The **Network Manager** accepts requests from local IBM users, IBM users on a connected node in VM, and requests from remote systems. For locally-initiated transfers, it establishes a path between the File Manager and the remote system and then acts as a router to the remote system. For remotely-initiated transfers, it passes the requests to the Node Manager.
- The **Node Manager** receives remotely-initiated requests from the Network Manager and passes them to the File Manager.
- The **File Manager** controls the file transfer.

In both VM and MVS, the DTF command processor is a separate physical component. In VM, the command processor is a CMS command processor and includes its own File Manager component. In MVS, the command processor is a TSO command processor. In MVS, the Node Manager, Network Manager, and File Manager are all logical components and all reside in the Node Manager address space. In VM, the Node Manager and the File Manager for handling remotely-initiated requests reside in the Node Manager virtual machine, and the Network Manager logical component resides in the Network Manager virtual machine.

## 1.2 The OpenVMS/DTF Components

The OpenVMS/DTF software consists of seven logical components:

- The **DTF command processor** accepts nonrecoverable DTF requests and uses the SNADTF\$FAL component to complete the request.
- The **OpenVMS/DTF dispatcher** accepts incoming nonrecoverable and recoverable file transfer requests initiated on IBM DTF clients. It routes nonrecoverable requests to the server's local TRANSFER/DTF component. It routes recoverable file transfer requests to the TRANSFER/DTF component on the target OpenVMS node (which could be the local OpenVMS/DTF server).
- The **TRANSFER/DTF utility** accepts recoverable and nonrecoverable DTF requests from either local users through a command interface or from IBM users through the OpenVMS/DTF dispatcher. It sends locally-initiated requests to the DTF execution queue. It sends dispatcher-generated requests and locally-initiated non-queued requests directly to the SNADTF\$COPY component.

- The **OpenVMS/DTF queue controller (symbiont)** manages the DTF execution queues and synchronously invokes the SNADTF\$COPY component for each job it takes off the queues.
- The **SNADTF\$COPY** component accepts file transfer requests directly from the TRANSFER/DTF utility in the case of IBM-initiated requests and non-queued locally-initiated requests, or from the DTF queue controller (symbiont) in the case of queued locally-initiated requests. It uses the SNADTF\$FAL component to complete the request. The SNADTF\$COPY component provides the recoverable copy features available to OpenVMS and IBM users.
- The **SNADTF\$FAL** component is used by local and remote DTF command processors and by the SNADTF\$COPY component to perform the individual file operations necessary to complete the file request.
- The **SNADTFCFG utility** is used to maintain the OpenVMS/DTF server databases.

On OpenVMS nodes, the DTF command processor is the DCL command processor. On ULTRIX and Digital UNIX nodes, the DTF command processor is a collection of DECnet-ULTRIX file transfer commands. On RSX-11M /M-PLUS nodes, the DTF command processor is either the DCL command processor or one of the file transfer programs provided with DECnet-RSX (NFT or FTS). On MS-DOS and OS/2 nodes, the DTF command processor is the NFT program provided with the PATHWORKS for DOS or PATHWORKS for OS/2 software.

The SNADTF\$FAL component is a DECnet object on the OpenVMS/DTF server. When invoked remotely, the TRANSFER/DTF utility is the DECnet object SNARCOPY on the OpenVMS/DTF server and, optionally, on other OpenVMS client systems. The same software can also be invoked locally as an executable image. The SNADTF\$COPY component is an executable image of the same name. The OpenVMS/DTF queue controller (symbiont) is the executable image SNADTF\$SYMBIONT. The OpenVMS/DTF dispatcher is the executable image SNADTF\$DISPATCHER. The SNADTFCFG utility is always on the OpenVMS/DTF server and, optionally, can be located on other OpenVMS client systems.

## 1.3 DTF for IBM Software Initialization

**MVS** The DTF software is initialized on MVS systems using the following process:

1. The Node Manager is typically started by the operations staff after every IPL.
2. The Node Manager starts the integrated Network Manager during the initialization phase.
3. The OpenVMS/DTF server node must start a server session with the Network Manager. Refer to Section 1.4 for a discussion of server sessions and the dispatcher process.

After steps 1 and 2, DTF for MVS is able to service DECnet users but not IBM users. Service for IBM users is not available until step 3 is completed. VM users only require that the Network Manager be started – the Node Manager is not a requirement.

**VM** The DTF software is initialized on VM systems using the following process:

1. The Node Manager virtual machine is started by the operations staff issuing an AUTOLOG of that CMS ID after an IPL.
2. The Node Manager, if so authorized, will AUTOLOG the DTF Network Manager virtual machine.
3. After the Network Manager is started, the Node Manager will issue the IUCV/APPC connection to interconnect the two machines.
4. The OpenVMS/DTF server node must start a server session with the Network Manager. Refer to Section 1.4 for a discussion of server sessions and the dispatcher process.

After steps 1, 2, and 3, DTF for VM is able to service DECnet users but not IBM users. Service for IBM users is not available until step 4 is completed.

## 1.4 OpenVMS/DTF Software Initialization

The OpenVMS/DTF server software initialization is initiated by the server startup command procedure and consists of the following activities:

1. The volatile and permanent DECnet database entries for the FAL object are modified to point to a DTF command procedure. At the start of each file transfer request this command procedure will check for a symbol defined by the login file in the DTF account. If this symbol is found, then the SNAFAL program is run. If the symbol is not defined, then the standard DECnet FAL program is run.



2. The OpenVMS/DTF dispatcher is started.
3. The OpenVMS/DTF dispatcher reads the server account information from the OpenVMS/DTF server's account database for the server sessions indicated in the startup procedure. It uses the server account information to establish server sessions to the DTF for IBM software on the indicated IBM systems.
4. The DTF for IBM software initializes as described in Section 1.3.
5. The DTF queues are started.

The OpenVMS/DTF utilities software initialization is initiated by the utilities startup command procedure and consists of starting the DTF queues.

**Figure 1-1 Steps in an IBM-Initiated Nonrecoverable File Transfer to a DECnet Node**

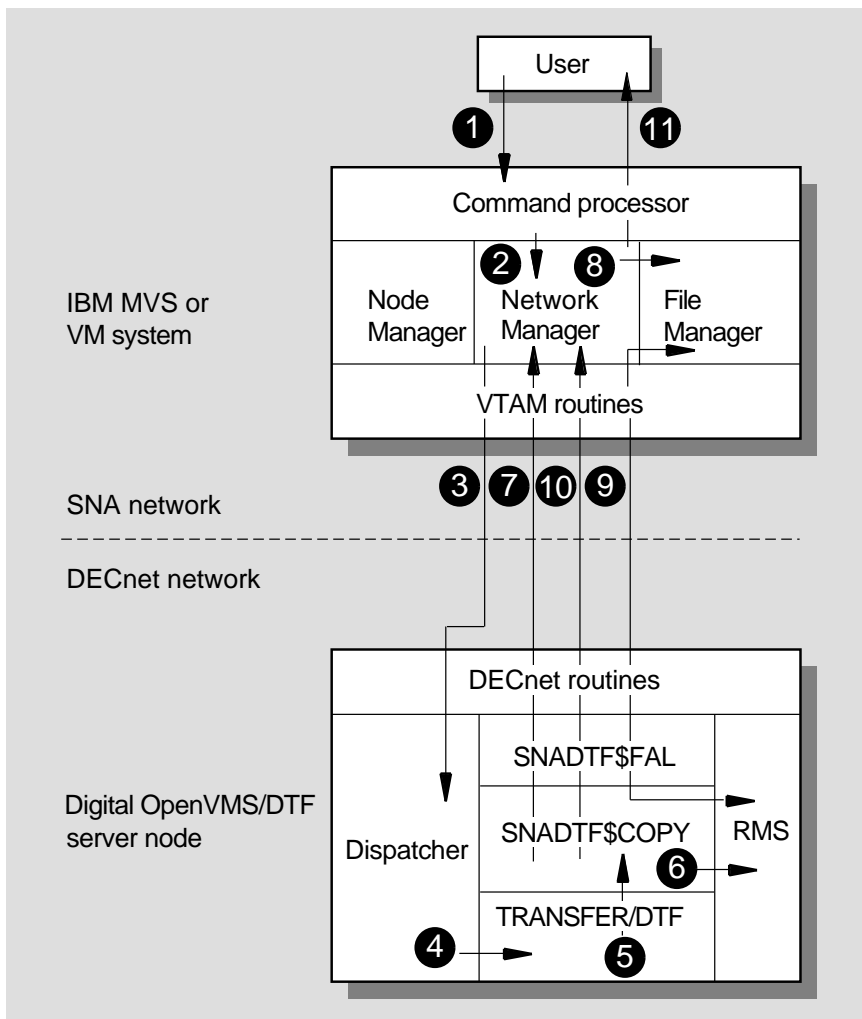

LKG-4409-93R

## 1.5 Nonrecoverable File Transfers Initiated from an IBM System to a DECnet System

Figure 1-1 shows the steps involved when you initiate a file transfer from DTF for IBM.

---

### Note

---

The TCP/IP can be used between the host running the SNADTF\$FAL process and the SNA Gateway and to connect into the SNA network. TCP/IP is only supported by the Digital SNA Domain Gateway and the Digital SNA Peer Server.

---

1. An IBM DTF user supplies transfer parameters to the command processor, command interface, or panel interface.
2. The DTF command processor submits the transfer request to the DTF Network Manager subsystem.
3. The DTF Network Manager contacts the dispatcher on an OpenVMS/DTF server node by using the server node specified by the IBM DTF user or by selecting a server node from a pool of active server nodes.
4. The dispatcher passes the request to the TRANSFER/DTF utility on the local node.
5. The TRANSFER/DTF parses the request and passes the request to the SNADTF\$COPY component.
6. The SNADTF\$COPY component, using local RMS services, accesses the local file. If the file is on another DECnet node, the SNADTF\$COPY component establishes a DECnet link to that node.
7. The SNADTF\$COPY component, using SNADTF\$FAL, establishes a transfer session back to the DTF Network Manager.
8. The DTF Network Manager passes the session to the DTF File Manager.
9. The file transfer proceeds to completion.
10. File transfer ends and the SNADTF\$COPY component terminates the transfer session. The SNADTF\$COPY component passes completion status back to the DTF Network Manager.
11. The DTF Network Manager passes the status to the command processor, and the command processor passes it on to the user.

**Figure 1-2 Steps in an IBM-Initiated Recoverable File Transfer to a DECnet Node**

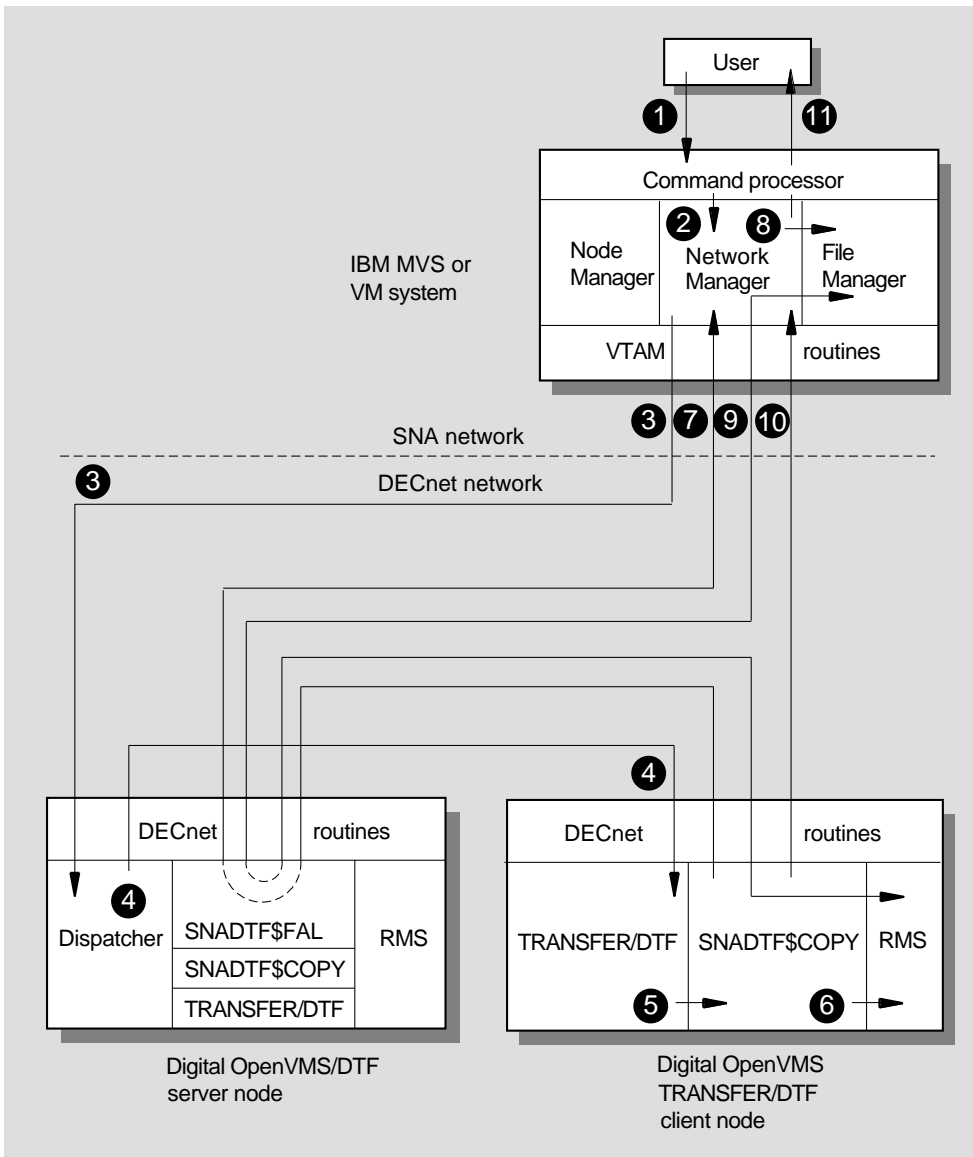

LKG-4417-93R

## 1.6 Recoverable File Transfers Initiated from an IBM System to a DECnet System

Figure 1–2 shows the steps involved when you initiate a recoverable file transfer from DTF for IBM.

---

### Note

---

The TCP/IP can be used between the host running the SNADTF\$FAL process and the SNA Gateway and to connect into the SNA network. TCP/IP is only supported by the Digital SNA Domain Gateway and the Digital SNA Peer Server.

---

1. An IBM DTF user supplies transfer parameters to the command processor, command interface, or panel interface.
2. The DTF command processor submits the transfer request to the DTF Network Manager subsystem.
3. The DTF Network Manager contacts the dispatcher on an OpenVMS/DTF server node by using the server node specified by the DTF user or by selecting a server node from a pool of active server nodes.
4. The dispatcher passes the request to the TRANSFER/DTF utility on the OpenVMS TRANSFER/DTF client node. This could be the server node if the server is also acting as a client in the transfer.
5. The TRANSFER/DTF utility parses the request and passes the request to the SNADTF\$COPY component.
6. The SNADTF\$COPY component on the TRANSFER/DTF client node accesses the local file using local RMS services.
7. The TRANSFER/DTF client's SNADTF\$COPY component, using the OpenVMS/DTF server's SNADTF\$FAL, establishes a transfer session back to the DTF Network Manager.
8. The DTF Network Manager passes the session to the DTF File Manager.
9. The file transfer proceeds to completion.
10. File transfer ends and the TRANSFER/DTF client's SNADTF\$COPY component terminates the transfer session. The TRANSFER/DTF client's SNADTF\$COPY component passes completion status back to the DTF Network Manager.

11. The DTF Network Manager passes the status to the command processor, and the command processor passes it on to the user.

**Figure 1-3 Steps in an IBM-Initiated File Transfer to a Different IBM System**

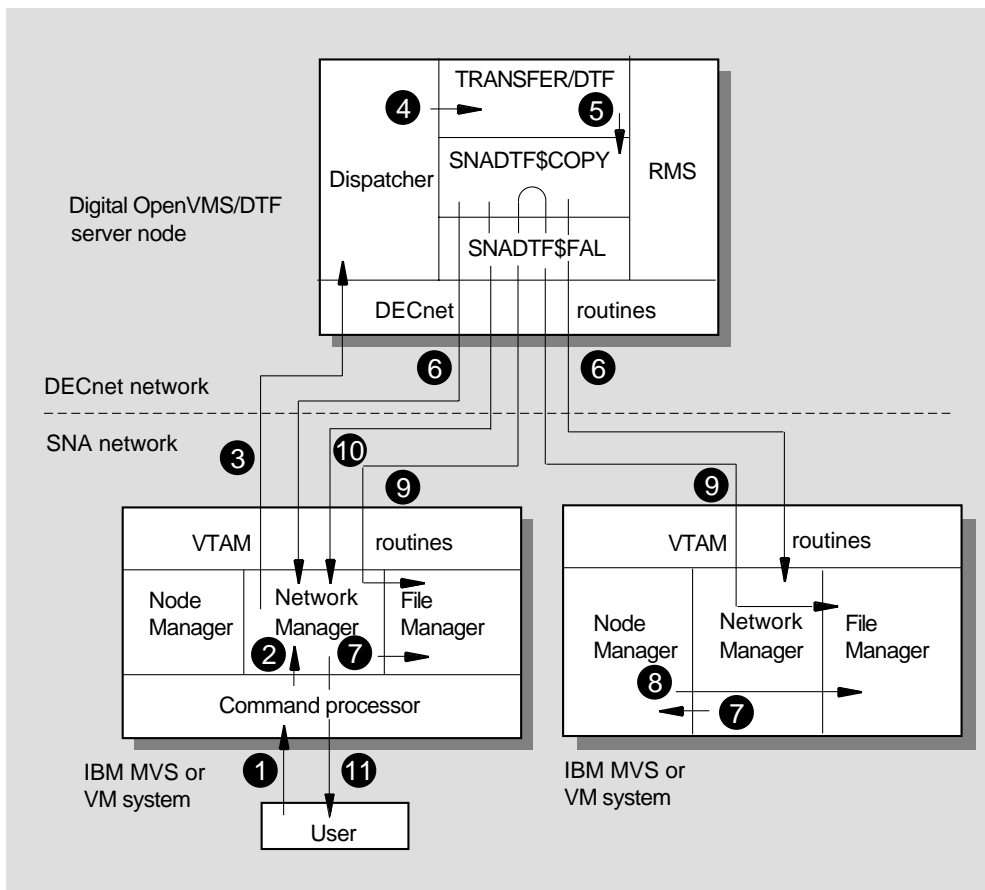

LKG-4410-93R

## 1.7 File Transfers Between Two IBM Systems

The DECnet or TCP/IP network can be used to copy files between two IBM systems as long as both systems have active DTF Network Manager subsystems and are connected, through gateways, to the same DECnet or TCP/IP network.

Figure 1–3 shows the software components used for an IBM-initiated file transfer request to a different IBM system. The description is the same for both recoverable and nonrecoverable file transfers.

---

### Note

---

The TCP/IP can be used between the host running the SNADTF\$FAL process and the SNA Gateway and to connect into the SNA network. TCP/IP is only supported by the Digital SNA Domain Gateway and the Digital SNA Peer Server.

---

1. An IBM DTF user supplies transfer parameters to the command processor, command interface, or panel interface.
2. The DTF command processor submits the transfer request to the DTF Network Manager subsystem.
3. The DTF Network Manager contacts the dispatcher on an OpenVMS/DTF server node by using the server node specified by the DTF user or by selecting a server node from a pool of active server nodes.
4. The dispatcher passes the request to the TRANSFER/DTF utility on the server node that services the target IBM system. This could be the dispatcher's local server node if the server is also acting as a client in the transfer. (This is the case shown.)
5. The TRANSFER/DTF utility parses the request and passes the request to the SNADTF\$COPY component.
6. The SNADTF\$COPY component, using SNADTF\$FAL, establishes a transfer session with both the target and source Network Managers.
7. On the initiating IBM system, the DTF Network Manager passes the session to the DTF File Manager. On the target IBM system, the DTF Network Manager passes the session to the DTF Node Manager.
8. On the target IBM system, the DTF Node Manager finds an available File Manager and passes it the transfer request.



9. The two File Managers use their respective Network Managers to communicate with one another and the file transfer proceeds to completion.
10. File transfer ends and the SNADTF\$COPY component terminates the transfer session. The SNADTF\$COPY component passes completion status back to the DTF Network Manager on the source system.
11. The DTF Network Manager passes the status to the command processor, and the command processor passes it on to the user.

Figure 1-4 Steps in a DECnet-Initiated Nonrecoverable File Transfer

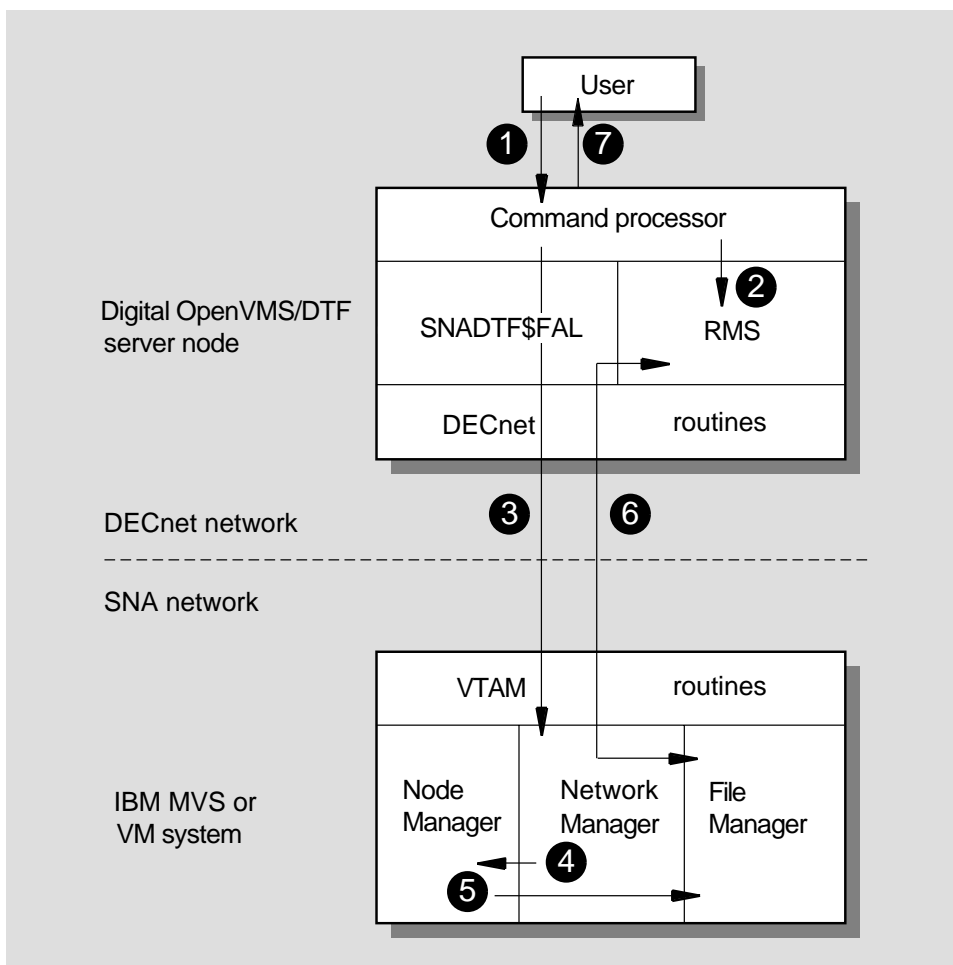

LKG-4411-93R

## 1.8 Nonrecoverable File Transfers Initiated from a DECnet Node

Figure 1-4 shows the steps involved in a DECnet-initiated nonrecoverable file transfer.

---

### Note

---

The TCP/IP can be used between the host running the SNADTF\$FAL process and the SNA Gateway and to connect into the SNA network. TCP/IP is only supported by the Digital SNA Domain Gateway and the Digital SNA Peer Server.

---

1. The user initiates a file transfer request using the DCL command processor.
2. The command processor, using local RMS services, accesses the local file.
3. The command processor, using SNADTF\$FAL, establishes a transfer session with the target system's DTF Network Manager using the session characteristics stored for that transfer session in the server account database.
4. The Network Manager passes the request to the Node Manager.
5. The Node Manager passes the transfer request to the File Manager.
6. The File Manager connects to the Network Manager and uses the Network Manager to carry out the file transfer which is controlled by the DCL command processor.
7. The DCL interface concludes the transfer and issues status to the local user.

**Figure 1-5 Steps in a DECnet-Initiated Recoverable File Transfer**

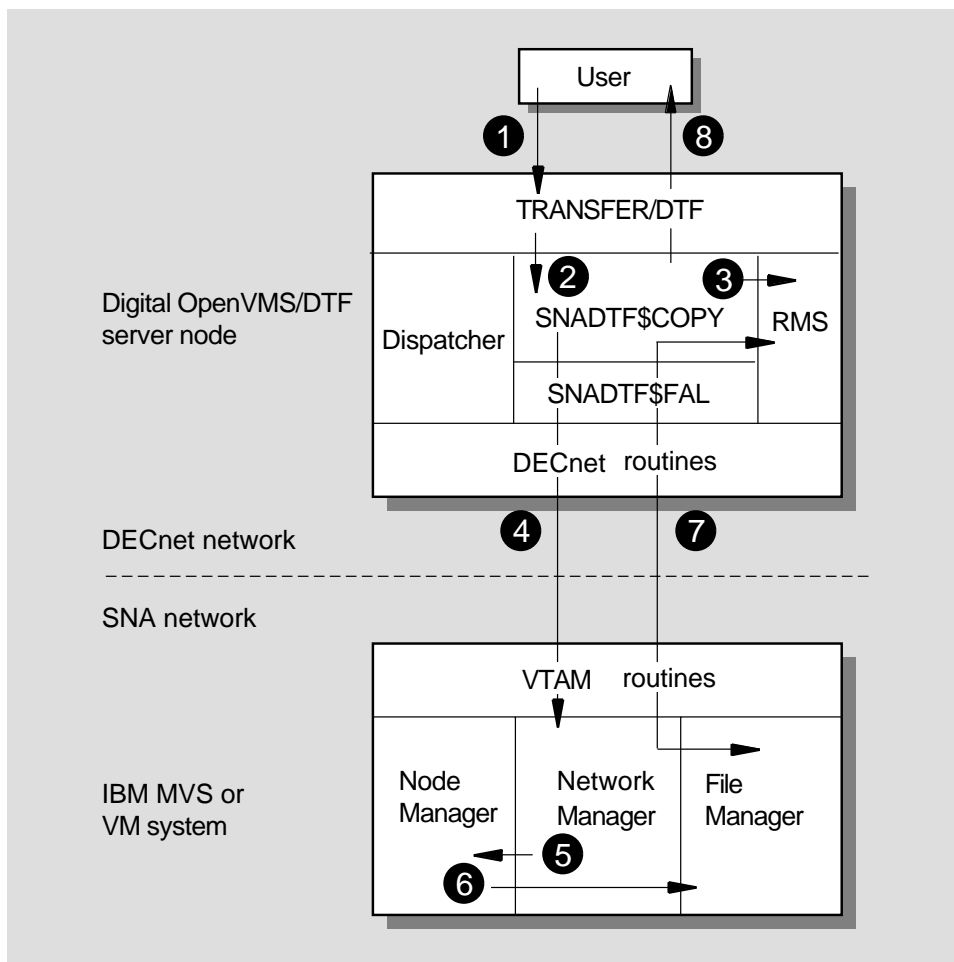

LKG-4989-93R

## 1.9 Recoverable File Transfers Initiated from a DECnet Node

Figure 1–5 shows the steps involved in a DECnet-initiated recoverable file transfer.

---

### Note

---

The TCP/IP can be used between the host running the SNADTF\$FAL process and the SNA Gateway and to connect into the SNA network. TCP/IP is only supported by the Digital SNA Domain Gateway and the Digital SNA Peer Server.

---

1. The user initiates a file transfer request using the TRANSFER/DTF utility.
2. The TRANSFER/DTF parses the request and passes the request to the SNADTF\$COPY component.
3. The command processor or the SNADTF\$COPY component, using local RMS services, accesses the local file.
4. The command processor or the SNADTF\$COPY component, using SNADTF\$FAL, establishes a transfer session with the target system's DTF Network Manager using the session characteristics stored for that transfer session in the server account database.
5. The Network Manager passes the request to the Node Manager.
6. The Node Manager passes the transfer request to the File Manager.
7. The File Manager connects to the Network Manager and uses the Network Manager to carry out the file transfer which is controlled by the DCL command or the DECnet file transfer command.
8. The DCL interface or the SNADTF\$COPY component concludes the transfer and issues status to the local user.



# 2

---

## Isolating DTF Software Problems

The DTF software has many different components that operate both on the OpenVMS/DTF server node and on IBM (MVS or VM) DTF clients. DTF provides interfaces to both DECnet or TCP/IP users and IBM users. Because of the distribution of the components, the first step in the problem determination process is usually to isolate the problem to either OpenVMS/DTF or DTF for IBM.

OpenVMS/DTF provides a service to users on a DECnet network node. Frequently, problems with DTF software will first become apparent to those users. This will frequently result in the OpenVMS system manager becoming involved before the IBM system programmer. Therefore, the OpenVMS system manager must perform simple problem resolution for DTF for IBM software to isolate the problem.

DTF for IBM includes a command processor and a panel interface to the DECnet network or TCP/IP node. Problems with these components usually involve the IBM system programmer, who must perform simple problem resolution for OpenVMS/DTF to isolate the problem.

In both cases the systems people involved will probably follow the course of attempting all problem solving techniques on their own systems first. After this step is done, they will probably have to approach their counterpart on the other system for assistance.

The goal of problem isolation is to classify the problem as one of the following:

1. Usage problem
2. Installation error
3. Software error

## 2.1 Usage Problems

Most DTF problem determination occurs in the area of usage problems. The DTF software ties together three different file management systems. The OpenVMS file management system is referred to as **Record Management Services (RMS)**. The MVS file management system is handled by the **Data Facility Product (DFP)**. The VM file management system is part of the **Conversational Monitor System (CMS)** facility. DTF provides IBM users with access to RMS files and also provides Digital users with access to DFP files and CMS files.

Because the file management systems are quite different, usage errors can be caused by a user's failure to understand how the remote file systems operate. For example, RMS-managed files are written to devices with fixed block sizes of 512 bytes. Because this is a fixed value, Digital users do not have to be conscious of block sizes when creating files. In contrast, DFP can be used to write files with varying block sizes. Consequently, MVS users are very conscious of block sizes when they create files because improper blocking can result in poor usage of disk space.

Another major difference in the two file systems is the syntax of their file specifications. DTF requires that users on both the IBM side and the Digital side understand the syntax of the remote file specification. The *OpenVMS Digital Command Language Concepts* manual provides a good introduction to the RMS file syntax for IBM users. Although the *MVS JCL Reference Manual* should be used as a reference manual and not as a primer for new users, it can provide Digital users with a good introduction to DFP. The *VM/SP Primer* provides Digital users with a good overview of CMS file concepts.

DTF reports usage errors to the originator of the request. Since there is a difference in the two file systems, the user may not understand the error message. In such a case, the OpenVMS system manager or the IBM system programmer must investigate the problem and explain the error to the user.

### 2.1.1 Isolating DTF for IBM Usage Errors

DTF for IBM usage errors appear as messages received by users through the DTF command processor, DTF panel interface, or single-line command interface. These messages are transient; once the user clears the screen, the messages are lost. Therefore, it is important to get the complete text of the error message from the user before the message is lost.



DTF for IBM usage errors are detected by both DTF for IBM and OpenVMS /DTF. If DTF for IBM detects the usage error, the terminal displays a message that begins with the "DTF" characters. Appendix A explains these messages. The explanation of the message should suggest whether this is a usage error or another type of error.

If the OpenVMS/DTF server software detects the usage error, the message is returned in OpenVMS format. These error messages are intended to be readable so that users can understand their mistakes without referring to a message manual. If you cannot understand the message text, you may need to refer to either the *VMS Messages/Recovery Procedures Reference Manual* or Appendix C. Refer to Appendix C for messages beginning with DTF and RMS. Refer to the OpenVMS messages manual for all other messages.

If the reason cannot be determined from reading the message's User Action section, this is probably not a usage error.

### 2.1.2 Isolating OpenVMS/DTF Usage Errors

Usage errors in OpenVMS/DTF appear to Digital users as error messages on their screens. Most error messages have enough information in them to explain what caused the error. Two additional usage problems are discussed in the following sections.

#### Problems Reaching the OpenVMS/DTF Network Object

Although this problem may sound like a network problem it is usually due to a usage error. All IBM file specification qualifiers must be entered using a colon (:) instead of the equals sign (=). If an equals sign is included in the IBM file specification the following message is given:

```
-SYSTEM-F-NOSUCHOBJ, network object is unknown at remote node
```

Reentering the command with the colon should solve the problem.

#### Coded Error Messages

Unfortunately, usage errors that are caused by inconsistencies in the file systems do not have concise text messages. These errors return error codes instead of text messages. On OpenVMS TRANSFER/DTF clients, the error codes can be interpreted using the TRANSFER/DTF or SNADTFCFG utility's SHOW ERROR command (see the *Digital SNA Data Transfer Facility for OpenVMS Use* manual). On other clients or where TRANSFER/DTF is not available, a table in Appendix D provides the ASCII message code for these errors. The complete message text can then be looked up in Appendix E.

Often the reason for errors generating coded messages must be traced to the DTF for IBM SYSPRINT file. Section 3.1 explains how to examine internal messages.

Every status message sent by DTF for IBM is logged in the SYSPRINT file with message DTF2403I. This message shows the status code in both the octal format and the transmission format. The octal format is used to find the code in the Digital manual *DAP Access Protocol Functional Specification*. The transmission format is used by OpenVMS/DTF software to report the error to the OpenVMS user.

Message DTF2403I has a second line that describes the error code for some of the more common errors. If the message does not have this line, the message that preceded the DTF2403I message usually describes the error that caused the status code to be sent. If the DTF2403I message was not preceded by an error message, you must use either the DAP functional specification or Table 2-1 to find the error.

Table 2-1 shows all the IBM-specific status codes that are not listed in the functional specification. These are used by DTF for IBM to report usage errors for parameters that are unique to IBM.

**Table 2-1 IBM-Specific Status Codes**

Octal Format	Transmission Format	Meaning
027622	922F	The block size specified is not valid for the record format or record length.
027626	962F	The density value is invalid.
027633	9B2F	The label parameter is invalid.
027636	9E27	The retention period is invalid.
027641	A12F	The IBM volume is not supplied when a volume name is required.
040501	4141	Cleanup is requested because the IBM operator is shutting down DTF.
040504	4441	A READ checkpoint has been reached.
040513	4641	SVC 99 failure during allocation of an old file. The SVC 99 error code and reason code are returned.
040514	4C41	SVC 99 failure during allocation of an old file. The SVC 99 error code and reason code are returned.

## 2.2 Installation Errors

DTF for IBM installation errors that are not caught with installation verification procedures could later appear in the following ways:

- The DTF for IBM command processor does not start.
- Transfer or server sessions do not start.
- DTF for IBM command processor or DTF panel interface error messages are returned.
- Privilege violations are reported to OpenVMS users.
- Low throughput on transfer sessions.
- Files are created with poor attributes.

If the problem can be traced to the DTF for IBM installation, the IBM system programmer must become involved in the problem determination process. In most cases, the system programmer should be able to correct the problem.

OpenVMS/DTF installation errors can appear in one of the following forms:

- Network-related error messages are reported to OpenVMS users.
- Unexplained syntax errors are reported to OpenVMS users.
- Transfer or server sessions do not start.
- DTF command processor or DTF panel interface requests are rejected.

If the problem can be traced to an OpenVMS/DTF installation error, the OpenVMS system manager must become involved in the problem determination process.

### 2.2.1 Isolating DTF for IBM Installation Errors

#### **DTF Command Processor Does Not Start**

Problems in starting a DTF component can be traced by using the return code. Appendix A describes these return codes. If initialization has proceeded far enough, there may also be messages in the SYSPRINT file.

#### **Transfer or Server Sessions Do Not Start**

Problems in starting transfer and server sessions can be traced through the SYSPRINT file or through the user sense code in the unbind. Messages DTF0202E, DTF0303E, and DTF0602E are all used to log failed session establishment requests. The most common reason for failed requests will be bad session parameters in the LOGMODE table entry. The *Digital SNA Data Transfer Facility Installation (VM)* or *Digital SNA Data Transfer Facility*

*Installation (MVS)* manual lists and explains the required logon mode table values.

#### **DTF Privilege Error Messages Returned to OpenVMS/DTF Users**

The DTF File Manager returns privilege violations to OpenVMS users if DTF for IBM encounters problems with the security exit. If the requested exit is unavailable or fails during operation, the DTF File Manager returns privilege violations to all requests.

A second cause of privilege violations may be problems with the proxy database. If the OpenVMS/DTF server's proxy database is being used, have the OpenVMS/DTF server manager check to be sure that the database is enabled and that it has the proper entries for the user experiencing the problem. On MVS systems, if the IBM proxy mechanism is being used check to be sure that the proper entry for the user has been made.

#### **Bad Throughput**

Bad throughput on the transfer session could be caused by poor selection of pacing and RU size parameters or by problem resolution options that are turned on in the DTF Network Manager during DTF for IBM software installation.

#### **Problems with File Creation Attributes**

Poor file creation attributes can usually be traced to DTF defaults set during DTF for IBM software installation. The OpenVMS interface allows substantial defaulting to occur in DTF. Since many IBM file creation parameters have no equivalent in RMS, OpenVMS users tend not to specify them. This causes the DTF default values to be used commonly at file creation time. IBM sites should set defaults during installation to control the default attributes of files created by OpenVMS users.

### **2.2.2 Isolating OpenVMS/DTF Installation Errors**

#### **Network-Related Problems**

If you receive the following error message when trying to transfer a file

```
-SYSTEM-F-LINKEXIT, network partner exited
```

check the NETSERVER.LOG file in the directory of the server account referenced in your request on the server node you are using for the file transfer. Since there may be many NETSERVER.LOG files, look for the one that was created in the appropriate timeframe. The NETSERVER.LOG file should contain information explaining the error. This problem is usually caused when the DTF server account does not have read access to certain files.

To solve the problem, check the NETSERVER.LOG file to see if it contains any of the following messages. This will tell you which files do not have the appropriate protection. Change the protection for the affected file so that it can be accessed by the server account.

If the server account cannot access the SNADTF\$LOGIN.COM or the system login command file, then the NETSERVER.LOG file contains the following message:

```
%DCL-E-NOCMDPROC, error opening captive command procedure - access denied
```

If the server account cannot access the NETSERVER.COM file, then the NETSERVER.LOG file contains the following messages:

```
Error opening primary input file SYS$INPUT  
Insufficient privilege or file protection violation
```

If the server account cannot access the SNADTF\$FAL.COM file, then the NETSERVER.LOG file contains the following messages:

```
%DCL-E-OPENIN, error opening SYS$SYSROOT:[SYSEXE]SNADTF$FAL.COM as input  
-RMS-E-PRV, insufficient privilege or file protection violation
```

### **Unexplained Syntax Errors**

You may experience an error even though the file specification has been entered correctly. If the file specification looks correct:

- Check the network object database on the server node and make sure that the file identification for the FAL object is SYS\$SYSTEM:SNADTF\$FAL.COM.
- Use the AUTHORIZE utility to make sure that the referenced server account is a DTF server account.

### **Transfer or Server Sessions Not Running**

An OpenVMS/DTF installation error often appears before a session to the DTF Network Manager is started. The best way to check this is to make the OpenVMS request, then check the SYS\$PRINT file to see if a session began. If no messages record the start of a session, the error is probably an installation error.

OpenVMS/DTF has a management utility on the server that allows the OpenVMS system manager to select session initialization parameters like VTAM APPLID and LOGMODE table entry for each server account. Server accounts are used for server and transfer sessions. If there is a mistake in these values, the session to the DTF Network Manager will never begin. *Digital SNA Data Transfer Facility for OpenVMS Management* describes the OpenVMS/DTF management utility.

### **Rejected Transfer Requests**

File transfer requests that fail before a transfer session begins can generally be traced to OpenVMS/DTF installation errors. *Digital SNA Data Transfer Facility for OpenVMS Use* explains how to correct these errors.

## **2.3 Software Errors**

DTF for IBM software errors appear as system errors or user request errors. OpenVMS/DTF software errors appear as system errors. The following sections explain how to isolate DTF for IBM and OpenVMS/DTF software errors.

### **2.3.1 Isolating and Reporting DTF for IBM Software Errors**

#### **System Errors**

System errors cause the DTF Network Manager address space to write an abend dump. On MVS systems this dump is directed to the SYSUDUMP (or SYSABEND or SYSMDUMP) data set. OpenVMS users are notified of this dump by a message that includes the "Operation aborted at remote node" text. The IBM operator does not see the dump until the DTF component is terminated.

#### **User Request Errors**

A user request error is one in which a request is wrongfully rejected or does not work as expected. These errors do not usually have dumps associated with them. You can usually duplicate this type of error.

If the user request results in a transfer session and the requested file is not successfully transferred, the error is probably with DTF for IBM software. These types of errors must be reported to the Digital support center. The information-gathering process requires involvement of the IBM system programmer. See Chapter 3 and Chapter 4 for more information.

### **2.3.2 Isolating and Reporting OpenVMS/DTF Software Errors**

#### **System Errors**

DTF for IBM has several built-in problem determination aids. These should be used prior to reporting a problem to the Digital support center. In addition, OpenVMS/DTF has excellent tracing functions that could help diagnose the DTF for IBM problem. See Chapter 5 for more information.

# 3

---

## Gathering Information on DTF for IBM Problems

Problem isolation information is available in DTF for IBM in an ongoing manner. If you suspect that a software error is causing the problem, you should use additional information-gathering tools to pinpoint the problem. Table 3-1 illustrates the types of information you should gather for common software errors. The Situation column lists the types of errors you could encounter. The remaining columns indicate the information collection tool you should use for each error situation.

**Table 3-1 Information Collection Tools for Common Software Errors**

Situation	Information Collection Tool						
	Abend Dump	Internal Trace	External Trace	DEBUG	PSW Ranges	OpenVMS Tools <sup>1</sup>	OpenVMS SYSPRINT Log
Transfer hangs	X	X				X	X
OpenVMS user aborts operation	X	X					X
SVC 99 failure				X			X
Sessions rejected				X		X	X
Failures during transfer		X	X			X	X
Looping	X	X	X	X	X		X

<sup>1</sup>See Chapter 5

(continued on next page)

**Table 3–1 (Cont.) Information Collection Tools for Common Software Errors**

Situation	Information Collection Tool					
	Abend Dump	Internal Trace	External Trace	DEBUG	PSW Ranges	OpenVMS Tools <sup>1</sup> SYSPRINT Log
DTF command processor or DTF panel interface errors		X		X		X X
Data integrity problems				X		X X
Network failures		X				X X
DTF component failure	X	X				X
Problems with VSAM file creation /deletion <sup>2</sup>						X X
Problems opening VSAM files		X		X		X X

<sup>1</sup>See Chapter 5

<sup>2</sup>Information also available in IDCAMS output - see Section 3.6

### 3.1 Examining the SYSPRINT File

DTF for IBM components write logs of all important events in the SYSPRINT file. Appendix A describes the common DTF message format. A listing of all messages follows the discussion of the common format.

**[MVS]** The SYSPRINT log file is generally not available until the DTF component is stopped. Your IBM site may have a utility that you can use to browse JES spool data sets while a job is still running. If your site has such a utility, you can examine the SYSPRINT file without stopping the DTF components.

**[VM]** When a DTF component is stopped, the SYSPRINT log file is automatically spooled to the print queue. The file may then be PEEKed or transferred to another virtual machine's reader for inspection.



---

**Note**

---

VM DTF users must set DTF\_LOG in the DTF EXEC file to YES to obtain a SYSPRINT log file from the DTF command processor.

---

## 3.2 Examining Abend Dumps

If a DTF component encounters an abend situation, it writes a dump. An abend dump from a DTF component is a signal of a software error. If your site finds data in the dump data set, you should call the Digital support center for help in determining the cause of the error.

**[MVS]** The dump is controlled by the designated dump DD card (SYSUDUMP, SYSABEND, or SYSMDUMP). You cannot examine these dumps until the DTF components have terminated.

**[MVS]** The DTF Node Manager does not write abend dumps if the DTF Node Manager was installed with DUMP(OFF) or if the MVS operator has used the DTF console interface to SET DUMP OFF. Chapter 4 describes the DTF console interface.

**[VM]** For CMS components, the dump is sent to the reader of the virtual machine. For GCS components, the dump is sent to a virtual machine designated by the VM system programmer. The dump can be analyzed by using IBM-supplied utilities. If the Digital support center requests dump tapes, please use the CP command SPTAPE to load the dump files onto tape.

## 3.3 Examining the Internal Trace Table

The internal trace table is used to record the sequence of events within the DTF component. It is very useful in determining the location of software errors. You can examine this trace table for information in abend dumps or when you are in DEBUG mode.

The DTF component will not trace unless the DTF component was installed with TRACE(ON) or unless the operator has used the DTF console interface, if available, to SET TRACE ON. Chapter 4 describes the DTF console interface.

## 3.4 Using the External Trace

The external trace allows for extra problem resolution information when the internal trace table is not large enough. The internal trace table of a DTF component is adequate for tracking errors that occur before file records start flowing during a transfer. After that point, the trace table is overwritten very quickly and some important events could be missed. In addition, if multiple transfers are executing, the trace information is overwritten even sooner. To compensate for this problem, you can enable external tracing which causes trace data to be written to both the internal trace table and to an external area.

### 3.4.1 External Tracing for MVS

External trace allows the MVS standard **generalized trace facility** (GTF) to be used to capture all trace information. This has the added benefit of allowing you to examine trace entries while the DTF component is still executing.

Before the DTF component begins using the external trace, the MVS system programmer must have started GTF in such a manner that it captures user data. To enable external tracing the MVS operator should start GTF, using the startup parameter USR. The MVS operator can then give the DTF console command SET EXTRACE ON to begin external tracing. Once the error has occurred, the DTF console command SET EXTRACE OFF should be used to end tracing. GTF should then be stopped and the trace data printed. Chapter 4 explains how to use EXTRACE from the MVS master console.

### 3.4.2 External Tracing in VM

The external trace feature uses the Monitor Call instruction to record trace data. This allows DTF to record trace data while DTF is still active.

To enable tracing you must instruct the operating system to begin trace data collection and instruct the DTF component to generate trace data.

To begin trace data collection enter the following commands:

**On non-XA systems:**

```
CPTRAP 3E
CPTRAP ALLOWID dtf-component-id
CPTRAP START TO *
```

**On XA systems:**

```
TRSOURCE ID DTF TYPE GT FOR USER dtf-component-id  
TRSAVE FOR ID DTF DASD TO *  
TRSOURCE ENABLE ID DTF
```

where *dtf-component-id* is the name of the virtual machine for which you wish to enable external tracing. Unless you specified different names during the DTF software installation, you should specify either DTFNET or DTFNODE.

To instruct the DTF component to generate trace data, log in to the component's console and enter the following commands:

**On the Node Manager's console:**

```
SET EXTRACE ON
```

**On the Network Manager's console:**

```
DTF SET EXTRACE ON
```

Once you have captured the necessary information in the trace you should instruct the DTF component to stop generating trace data and instruct the operating system to stop trace data collection.

To instruct the DTF component to stop generating trace data, log in to the component's console and enter the following commands:

**On the Node Manager's console:**

```
SET EXTRACE OFF
```

**On the Network Manager's console:**

```
DTF SET EXTRACE OFF
```

To stop trace data collection enter the following commands:

**On non-XA systems:**

```
CPTRAP STOP  
CPTRAP CLOSE
```

**On XA systems:**

```
TRSOURCE DISABLE ID DTF  
TRSOURCE DROP ID DTF
```

For both XA and non-XA systems you should refer to your IBM documentation on your trace facility. The commands shown in this section generate the minimum tracing information required by Digital. Many other system-supplied trace options are available and your site may have additional trace options.

## 3.5 Using DTF Component DEBUG Mode

DEBUG mode in a DTF component is useful when you are tracking system errors. It causes small, formatted memory dumps to be written that contain key pieces of memory involved in processing requests. Each piece of memory is coded with a three-digit SNAP ID. Table 3–2 lists these IDs.

The DTF component will not be in DEBUG mode unless the component was installed with DEBUG(ON) or unless the operator has used the DTF console interface command to SET DEBUG ON. Chapter 4 describes the console interface.

**[MVS]** The SNAPDUMP data set is generally not available until the DTF component has terminated. Your IBM site may have a utility you can use to browse JES spool data sets while a job is still running. If your site has such a utility, you can examine the SNAPDUMP data set without stopping the DTF component. **[VM]** The DEBUG facility uses the trace data collection facility described in Section 3.4.2. Follow the procedures presented in this section to enable the collection of DEBUG data.

**Table 3–2 SNAPDUMP ID Summary**

<b>SNAP ID</b>	<b>Description</b>
100	Bind image, user data, bind response, and session control blocks (SCB) of the transfer session
105	Bind image, user data, bind response, and SCB of the rejected session
110	Bind image, user data, bind response, and SCB of the control session
115	Transfer block being sent
116	IUCV transfer block being sent
120	SCB before teardown
125	Transfer block off receive queue
126	IUCV transfer block receive queue
130	File control block (FCB)
135	Resource request block (RRB)

(continued on next page)

**Table 3–2 (Cont.) SNAPDUMP ID Summary**

SNAP ID	Description
140	Resource request block (RRB) completed
144	Resource allocation block
145	SVC 99 parameter list resource work area (RWA) if dynamic allocation fails
150	Deallocate failed
155	Control session receive
165	TSO request block
170	Subsystem block
175	Subsystem on completion
180	Control session send
185	VTOC error on directory
250	Major blocks on shutdown

### 3.6 Examining IDCAMS Output

IDCAMS is a utility program provided by IBM. The DTF components use this utility to perform the following functions:

- Delete VSAM clusters (in a non-SMS environment)
- Define VSAM base clusters, alternate indexes built on the base clusters, and paths that link the alternate indexes to the base clusters
- Load the alternate indexes with the BLDINDEX command
- List VSAM file attributes

Normally, IDCAMS writes messages to the SYSPRINT file. The DTF component traps these messages and redirects them to other files. If you encounter problems with any of the previously listed functions, you should begin the problem determination process with these files.

IDCAMS writes messages that begin with the IDC characters as shown:

IDCxxxxy

The IBM manual *MVS System Messages* explains these messages. All other lines are IDCAMS control cards. The IBM manual *DFP: Access Method Services Reference* explains these IDCAMS control cards.

### 3.6.1 The IDCAMOUT File (MVS Only)

The IDCAMOUT DD card in the JCL that starts the DTF component specifies the IDCAMOUT file. Normally, it is sent to a JCL SYSOUT file that is automatically purged when the subsystem shuts down. If your site has a utility that enables you to display SYSOUT files, you can examine this file. If your site does not have such a utility, you should change the startup JCL so this file is saved.

The IDCAMOUT file contains a copy of the control cards that were used to request a function and all of the IDCAMS messages related to that function. All output (control cards and messages) is written to IDCAMOUT in a sequential manner, but the output is not separated on a per user basis.

The only IDCAMS command (and related messages) that is not written to this file is BLDINDEX. This is done when a VSAM cluster is created and loaded. Section 3.6.2 explains how to collect this information.

### 3.6.2 The VSAMLOG Option (MVS)

The DTF Node Manager has a VSAMLOG parameter that enables collecting IDCAMS commands that are issued and messages that are generated during the process of creating and loading a VSAM cluster. The *Digital SNA Data Transfer Facility Installation (MVS)* manual provides additional information about setting the VSAMLOG parameter during software installation. You can use the DTF SET VSAMLOG console command to change this parameter dynamically. Chapter 4 explains the DTF console commands.

If you specify the VSAMLOG parameter as ON, all of the IDCAMS output related to creating and loading a VSAM cluster will be collected in a generation data group file. This output includes the BLDINDEX command and related messages. A new generation will be created and written to on a per user request basis. Each generation relates to a specific user request; the output is not combined with other user requests, as it is in the IDCAMOUT file.

The VSAMLOGNAME parameter of the DTF Node Manager controls the name of the generation data group. The base generation data group record must have been defined before this parameter can work. The *Digital SNA Data Transfer Facility Installation (MVS)* manual describes the VSAMLOGNAME parameter and explains how to define the base generation data group record.

The default value for the VSAMLOGNAME is DTF.VSAMLOG. To examine the control cards and messages for the most recent user to have created and loaded a VSAM cluster, examine the most recent version of the generation data group. If your site has not changed the default name, the name is DTF.VSAMLOG(0). To examine a prior user's request, change the generation number to indicate

the previous version; for example, specify DTF.VSAMLOG(-1) to see the output from the user who made a request prior to the most recent user.

### 3.6.3 The VSAMLOG Option (VM)

The DTF Node Manager and command processor have a VSAMLOG parameter that enables collecting IDCAMS commands that are issued and messages that are generated during the process of creating and loading a VSAM cluster.

The *Digital SNA Data Transfer Facility Installation (VM)* manual provides additional information about setting the VSAMLOG parameter during software installation. You can use the DTF SET VSAMLOG console command to change this parameter dynamically. Chapter 4 explains the DTF console commands.

If you specify the VSAMLOG parameter as ON, all of the IDCAMS output related to creating and loading a VSAM cluster will be collected in a file. This output includes the BLDINDEX command and related messages.

The VSAMLOGNAME parameter of the DTF Node Manager controls the name of the file. The *Digital SNA Data Transfer Facility Installation (VM)* manual describes the VSAMLOGNAME parameter.





# 4

---

## Using the DTF Console

This chapter describes how to use the various IBM operating system console interfaces to solve problems with the DTF software.

### 4.1 The DTF Console Interfaces

The DTF console interfaces help with normal operations and problem determination. On MVS systems, the DTF component resides in the MVS operating system. On VM systems, DTF components reside in both the GCS and CMS operating system environments. Each of these operating systems enforces its own rules on the location of the console and the syntax necessary to communicate with the component. The following list shows the DTF components that have console interfaces and the operating systems in which these console interfaces run:

- MVS Node Manager - MVS
- VM Network Manager - GCS
- VM Node Manager - CMS

#### 4.1.1 The MVS Node Manager Console Interface

To use the MVS Node Manager console interface, use the following MVS MODIFY command:

```
MODIFY job-name,dtf-command dtf-qualifiers
```

where

*job-name* specifies either the name of the DTF Node Manager batch job or, if the DTF Node Manager is running as a started task, the name of the cataloged procedure.

*dtf-command* specifies a DTF console command described in Section 4.2.

*dtf-qualifiers* specifies a set of keywords that are understood by the *dtf-command*. A *dtf-qualifier* is separated from the *dtf-command* and other *dtf-qualifiers* by one or more spaces. A *dtf-command* has its own set of *dtf-qualifiers*, that are described in the section detailing the operation of that command.

The manual *MVS System Commands* describes the syntax for the MVS MODIFY command. You can abbreviate the MVS MODIFY command to F.

#### 4.1.2 The VM Network Manager Console Interface

To use the VM Network Manager interface, log into a disconnected machine and enter the following command:

```
DTF dtf-command dtf-qualifiers
```

where

*dtf-command* specifies a DTF console command described in Section 4.2.

*dtf-qualifiers* specifies a set of keywords that are understood by the *dtf-command*. A *dtf-qualifier* is separated from the *dtf-command* and other *dtf-qualifiers* by one or more spaces. A *dtf-command* has its own set of *dtf-qualifiers*, that are described in the section detailing the operation of that command.

The characters "DTF" must precede all DTF console commands or the commands will not be recognized.

#### 4.1.3 The VM Node Manager Console Interface

To use the VM Node Manager interface, log into a disconnected machine and enter the following command:

```
dtf-command dtf-qualifiers
```

where

*dtf-command* specifies a DTF console command described in Section 4.2.

*dtf-qualifiers* specifies a set of keywords that are understood by the *dtf-command*. A *dtf-qualifier* is separated from the *dtf-command* and other *dtf-qualifiers* by one or more spaces. A *dtf-command* has its own set of *dtf-qualifiers*, that are described in the section detailing the operation of that command.

## 4.2 DTF Console Commands

Table 4–1 shows the available DTF console commands and a brief description of their functions.

**Table 4–1 DTF Console Commands**

DTF Console Command	Function
INQUIRE	Examines DTF component activities.
SET	Controls problem determination options.
CLOSE	Stops the DTF component.

The following sections describe the INQUIRE, SET, and CLOSE DTF console commands and the qualifiers associated with each of the commands.

### 4.2.1 INQUIRE

Use the DTF INQUIRE command to examine activities within a DTF component. The syntax of the INQUIRE command is:

```
INQ[UIRE] { INTERCONN [access-number]  }  
           { NET [lu-name]  
           { TRANSFER [access-number]  
           { SERVER [node-name]
```

where

#### **INTERCONN *access-number***

Displays a summary of the DTF component connections to other DTF components for reasons not directly related to file access. The use of *access-number* is optional. If you do not include it, the DTF component lists all connections. If you include it, *access-number* must be an access number that is 5 digits long, right justified, and zero filled on the left.

The DTF component displays a summary about the requested connections. The summary includes IUCV or APPC send and receive counts.

#### **NET *lu-name***

Lists information about a VTAM network link to the DECnet or TCP/IP network. The use of *lu-name* is optional. If you do not include it, the DTF component lists all network links. If you include it, the *lu-name* must be the 1- to 8-character name assigned to the SNA logical unit (LU).

The DTF component displays a summary about the network link. The summary includes the SNA network name and the DTF session type (server or transfer). If it is a DTF server session, the output lists the DECnet node or TCP/IP host name of the server node. If it is a DTF transfer session, the output lists the access number and the IBM user ID.

#### **TRANSFER *access-number***

Displays a summary of the transfers being executed by the DTF component. The use of *access-number* is optional. If you do not include it, the DTF component lists all transfer sessions. If you include it, *access-number* must be an access number that is 5 digits long, right justified, and zero filled on the left.

The DTF component displays a summary of the transfer session by returning the network name being used by each transfer.

#### **SERVER *node-name***

Lists a summary of the server session links to the DTF component. The *node-name* is optional. If you do not include it, the DTF component lists all server sessions. If you do include it, *node-name* must be a DECnet node or TCP/IP host name.

The DTF Network Manager displays a summary of the server session by returning both the name of the network LU being used as a server session and the name of the server node that established the session.

### **4.2.2 SET**

The DTF SET command controls the use of problem determination aids within the DTF component. The syntax of the SET command is:

```
SET { EXTRACE ON | OFF
      DEBUG ON | OFF
      DUMP ON | OFF [MVS]
      PROXY ON | OFF | PROPAGATE [MVS]
      TRACE ON | OFF
      VSAMLOG ON | OFF }
```

where

#### **EXTRACE ON | OFF**

Controls the ability of the DTF component to write trace entries to an external source so you can examine them while the DTF component is still running. You can use this feature to track problems that occur at points that will be overwritten by later entries in the internal trace table.

If you specify `EXTRACE ON`, the internal trace is automatically activated. If you specify `EXTRACE OFF`, however, the internal trace is not turned off.

The `EXTRACE ON` setting should be used only for problem determination. Using this feature in a production environment is not recommended; it will degrade performance.

#### **DEBUG ON|OFF**

Controls whether or not small, formatted memory dumps are written during transfer operations.

The `DEBUG ON` setting should be used only for problem determination. Using this feature in a production environment is not recommended; it will degrade performance. In addition, it is not intended to function with multiple transfer sessions. Using it in this manner could cause internal errors.

#### **DUMP ON|OFF** MVS

Controls how dumps are written to the data set described by the `SYSABEND`, `SYSUDUMP`, or `SYSMDUMP` DD card. If you specify `DUMP ON` and the DTF component encounters an internal error, a dump will be taken.

The `DUMP OFF` setting should be specified only to avoid excessive print lines when the DTF component shuts down. The default is to take dumps on internal error situations. If your site has initiated the problem determination process by collecting the output of a dump, it may be desirable to avoid future dumps by specifying `DUMP OFF`.

It is recommended that the dump option remain `ON` so that problem determination is not hindered. This does not affect performance in a production environment.

#### **PROXY ON|OFF|PROPAGATE** MVS

Allows the installation to alter the current setting of the `PROXY` value.

At the startup of the DTF address space, the `PROXY` file is allocated if `PROXY` is `ON` and `PROXYDSN(...)` is specified. This prohibits the installation from customizing the `PROXYDSN` file after startup by using ISPF. The main intent of this keyword is to allow installations to customize the proxy file on the IBM system without requiring a shutdown and startup of DTF. Table 4-2 describes what happens when the `PROXY` setting is changed by using the `SET` command.

**Table 4–2 PROXY Settings and Descriptions (MVS Only)**

Current Setting	New Setting	Descriptions
OFF	ON <sup>1</sup>	PROXYDSN file will be allocated if defined in NODEPARM. The next DECnet or TCP/IP initiated request requiring an IBM user ID will cause the PROXYEXIT to be invoked.
	OFF	No action.
	PROPAGATE	The next DECnet or TCP/IP initiated request requiring an IBM user ID will have the DECnet or TCP/IP user ID assigned to the IBM user ID.
ON	ON	No action.
	OFF	If the PROXYDSN file is allocated, it will be deallocated. All subsequent DECnet or TCP/IP requests will require a /USERID (if security is enabled).
	PROPAGATE	If the PROXYDSN file is allocated, it will be deallocated. The next access requiring an IBM user ID will have the DECnet or TCP/IP user ID assigned to it.
PROPAGATE	ON <sup>1</sup>	The PROXYDSN file will be allocated if it is defined in NODEPARM. The next DECnet or TCP/IP initiated request requiring an IBM user ID will cause the PROXYEXIT to be invoked.
	OFF	All subsequent DECnet or TCP/I initiated accesses will require a /USERID (if security is enabled).
	PROPAGATE	No action.

<sup>1</sup>You have to define PROXYEXIT *program-name* in NODEPARMS at startup.

**TRACE ON|OFF**

Controls the ability of the DTF component to write trace entries to an internal trace table. If you specify TRACE ON, the DTF component writes its internal trace entries to the trace table. When the table fills, it wraps and overwrites the earliest entries.

The TRACE ON setting should be used only for problem determination. Using this feature in a production environment is not recommended; it will degrade performance.

### **VSAMLOG ON|OFF**

Controls how to save the SYSPRINT output from invoking IDCAMS to do DEFINE and BLDINDEX commands. Section 3.6.2 describes how the VSAMLOG parameter works.

VSAMLOG ON directs the DTF component to create files for saving all IDCAMS SYSPRINT output on a per user basis.

VSAMLOG OFF directs the DTF component to stop creating files where IDCAMS SYSPRINT output on a per user basis is saved.

### **4.2.3 CLOSE**

Use the DTF CLOSE command to stop the DTF component. The syntax of the CLOSE command is:

```
CLOS[E]      { QUIESCE | IMMEDIATE }
```

where

#### **QUIESCE**

Asks the DTF component to stop accepting new sessions and user requests but to allow all existing transfer sessions and user requests to complete. After all transfers and user requests have completed, the DTF component completes. The default is QUIESCE.

The DTF Network Manager automatically begins a quiesced shutdown when VTAM begins a quiesced shutdown.

#### **IMMEDIATE**

Notifies all users of a shutdown. All transfers are notified of an immediate shutdown and the remote DECnet node or TCP/IP host begins cleaning up the transfer.

An immediate shutdown does not complete until all transfer sessions are released. Server sessions are released immediately. Transfer sessions are released after the DECnet node or TCP/IP host completes cleaning up.

If the remote node is in an unknown state, the transfer session may never be cleaned up. In this case, the VTAM link must be forced down before the DTF component can complete the shutdown. You can terminate the VTAM session by using the VTAM VARY command with the FORCE option. Refer to the *VTAM Operator Commands* manual for the syntax of this command.

---

**Note**

---

You can use the MVS CANCEL command to cancel the DTF Node Manager. However, you should not do this until you have attempted an immediate shutdown. A cancel could affect the memory allocated by the MVS security system. In particular, ACF2 protects its memory by recommending that the definition for a MUSASS allow the DTF component to be set to NONCANCEL.)

---



---

## Gathering Information on OpenVMS/DTF Problems

This chapter discusses three methods for gathering problem determination information on the OpenVMS/DTF software. These methods range from gathering information about the DTF processes to gathering information about the actual network links used to carry the DTF transfers.

### 5.1 Using the SNALOG\_MASK Facility

Use the SNALOG\_MASK facility to obtain detailed information on the SNADTF\$DISPATCHER, SNADTF\$FAL, and SNADTF\$SYMBIONT processes. This facility is a valuable tool for the diagnosis of DTF software problems. To enable this facility, you must define the logical name SNALOG\_MASK.

#### 5.1.1 Defining the SNALOG\_MASK Logical

You should define the SNALOG\_MASK logical name only when you are diagnosing a problem. The SNALOG\_MASK logical name should be defined in a logical name table that is accessible from the process that is running the image you wish to trace.

---

**Note**

---

Since this facility can be used by all the layered product images that use the Digital SNA Gateway, performance can be degraded if SNALOG\_MASK is defined as a system-wide logical.

---

To define the SNALOG\_MASK logical name, include the following line in the file indicated in the three subsections that follow Table 5-1:

```
$ DEFINE SNALOG_MASK hex-value
```

The value *hex-value* determines the type of information to be logged. Each bit in *hex-value* can be broken down into groups of four bits. Each group of four bits corresponds to an access routine or layer of software. Table 5–1 shows this correspondence. A '0X' must be specified prior to the hex-value.

**Table 5–1 SNALOG\_MASK Bit Definitions**

0-3	Gateway Access Interface layer
4-7	Extended Application Interface layer
8-11	Used by other products
12-15	New Application Interface layer
16-19	Used by other products
20-23	Digital SNA Data Transfer Facility for OpenVMS Used by other products
24-27	General Communicatins Interface layer
28-31	Reserved

If bit 30 is set, the tracing subsystem logs informational messages to SYSS\$OUTPUT to indicate when the trace file has been opened or closed. If bit 31 is clear, the messages in the trace file are timestamped. If bit 31 is set, the messages in the trace file are not timestamped.

#### Using SNALOG\_MASK with the SNADTF\$FAL Process

To capture trace output for the transfer sessions of the SNADTF\$FAL.EXE image, SNALOG\_MASK must be defined as a process logical name in the process that is running that image. This is done by placing the DEFINE SNALOG\_MASK command in the LOGIN.COM file located in a server account's default directory. Each transfer will create a separate trace file.

When tracing the SNADTF\$FAL process, the SNALOG\_MASK bits 20 through 23 are used in the following manner:

Value	Information Collected
00100000	Routine tracing.
00200000	Important events such as SNA session startup and shutdown, DECnet logical link startup and shutdown, DAP messages, and error signaling.
00400000	AST posting and delivering.
00800000	Data structure allocation and deallocation.

#### Using SNALOG\_MASK with the SNADTF\$DISPATCHER Process

To capture trace output for the server sessions of the

SNADTF\$DISPATCHER.EXE image, SNALOG\_MASK must be defined as a process logical name in the process that is running that image. This is done by placing the DEFINE SNALOG\_MASK command in the SNADTF\$STARTUP\_SERVER.COM file located in SYS\$STARTUP. Since the log file will capture server session data for all server sessions you may want to capture trace data only during times when there are no other DTF users. The trace file will remain open until the SNADTF\$DISPATCHER process is stopped.

When tracing the SNADTF\$DISPATCHER process, the SNALOG\_MASK bits 20 through 23 are used in the following manner:

Value	Information Collected
00100000	Routine tracing.
00200000	Server session protocol message logging.
00400000	Unused.
00800000	Unused.

#### Using SNALOG\_MASK with the SNADTF\$SYMBIONT Process

Since you cannot modify a login command file (because the symbiont process is started by the system queue manager) you must use a different method to collect information about the SNADTF\$SYMBIONT process. The best way to trace the symbiont process is to define SNALOG\_MASK in the group logical table for UIC [1,4] by including the following line in the SNADTF\$STARTUP\_SERVER file located in SYS\$STARTUP:

```
$ DEFINE/TABLE=LN$GROUP_000001 SNALOG_MASK hex-value
```

You must then stop and restart the symbiont by running the OpenVMS/DTF server startup command file.

When tracing the SNADTF\$SYMBIONT process, the SNALOG\_MASK bits 20 through 23 are used in the following manner:

Value	Information Collected
00100000	Routine tracing.
00200000	Signaling, entrance into and exit from symbiont, and message types.
00400000	Unused.
00800000	Unused.

## 5.1.2 Directing the SNALOG\_MASK Trace Output

By default, the output from the SNALOG\_MASK trace facility is placed in SNADTF\$MANAGER:SNALOG.DAT. To help prevent confusion, you can direct your trace output to a file other than SNADTF\$MANAGER:SNALOG.DAT. You might use this command if you wanted trace output that is related to a particular process. To do this, edit the same command file to which you added the DEFINE SNALOG\_MASK command to include the following line:

```
$ DEFINE SNALOG_FILE output-file-spec
```

For example, if you want information only about the connection between OpenVMS and an IBM system during a transfer session, then you would define SNALOG\_MASK to trace the SNADTF\$FAL process, and you might define SNALOG\_FILE to be SNADTF\$FAL\_TRC.LOG by including the following line:

```
$ DEFINE SNALOG_FILE SNADTF$FAL_TRC.LOG
```

The SNALOG\_MASK trace output for the SNADTF\$SYMBIONT process is always written to the following file:  
SNADTF\$MANAGER:SNADTF\$SYMBIONT\_TRC.LOG

## 5.1.3 Using SNALOG\_MASK When Submitting SPRs

When submitting a Software Performance Report (SPR) to Digital, you should include an SNALOG\_FILE file that was generated with the SNALOG\_MASK defined as follows:

```
$ DEFINE SNALOG_MASK 0X70F00000
```

Specifying bits 20-23 produces trace output for DTF-specific events.

If the problem involves SNA processing, you should define SNALOG\_MASK follows:

```
$ DEFINE SNALOG_MASK 0X70F000FF
```

Since DTF includes the New Application Interface, Extended Application Interface, Gateway Access Interface and General Communications Interface layers, specifying bits 0-7 traces the messages received and transmitted from these layers by the image.

## 5.2 Using the SNATRACE Facility

You can use the SNATRACE facility to gather information about the SNADTF\$DISPATCHER or SNADTF\$FAL processes. Refer to the *DECnet SNA Gateway Problem Determination Guide* or the *OpenVMS SNA Problem Determination Guide* for more information on how to use this facility.

### 5.3 Using the NETTRACE Facility

You can use the NETTRACE facility to gather information about the circuit and physical line between the SNA Gateway or TCP/IP host and the IBM system. Refer to the *DECnet SNA Gateway Problem Determination Guide* or the *OpenVMS SNA Problem Determination Guide* for more information on how to use this facility.

### 5.4 Using the CTF Facility

You can use the CTF facility to gather information about the SNADTF\$DISPATCHER or SNADTF\$FAL processes. Refer to the *Digital SNA Domain Gateway Management* or the *Digital Peer Server Management* for more information on how to use this facility.



# A

---

## DTF for IBM Messages

This appendix lists all of the messages that you could receive while using the DTF for IBM software. The format of each message consists of the DTF acronym followed by a four-character message ID and a severity code:

DTF`xxxxs`

THE ACTUAL DTF MESSAGE

**Recipients:** *n*

**Explanation:** Explains what the message means.

**User Action:** Describes what action, if any, you need to perform.

**Note:** Provides any additional information.

The *s* variable for the severity code will be one of the following:

- I — The message is informational.
- W — The message is a warning.
- E — There is an error.
- S — There is a severe error.

The *n* variable in the Recipients field describes one or more of the following message actions:

- 0 — The message is logged to the SYSPRINT file.
- 1 — The message is sent to the console.
- 4 — The message is sent to a user.
- 8 — The message is not logged to the SYSPRINT file.

A number other than 0, 1, 4, or 8 indicates more than one message action. For example, a recipient code of 9 means that the message was sent to the console (recipient code 1) and was not logged to the SYSPRINT file (recipient code 8). Some DTF for IBM messages also contain information about return codes.

## A.1 Messages

The rest of this appendix lists all the DTF for IBM messages, which are arranged by prefix (messages prefixed by DTFM precede messages prefixed by DTF). Within each prefix messages are arranged by number.

DTFM001W

*file-name* CHANGED TO NON-IBM FORMAT OR ZEROED - SOME  
PARAMETERS ARE NULLIFIED

**Recipients:** 1

**Explanation:** The indicated INFILE or OUTFILE was either changed from an IBM file specification to a non-IBM file specification or was set to the null value. This resets IBM-related parameters to the null value.

**User Action:** Informational. No action is necessary. This is a normal message when a file specification is changed from IBM to non-IBM format.

DTFM002E

TOO MANY CHARACTERS IN PARAMETER *param-name*

**Recipients:** 1

**Explanation:** The indicated parameter has too many characters.

**User Action:** Reduce the number of characters and retry the operation.

DTFM003E

MISMATCH ON INFILE AND OUTFILE, BOTH ARE NON-IBM FILES

**Recipients:** 1

**Explanation:** Either the INFILE or the OUTFILE must be an IBM file specification.

**User Action:** Find the file specification that is meant to be an IBM file specification and correct the syntax so that it is recognized as an IBM file specification and retry the operation.

DTFM004E

UNPAIRED PARENTHESIS IN PARAMETER *param-name*

**Recipients:** 1

**Explanation:** The indicated parameter contains an unpaired parenthesis.

**User Action:** Add the missing parenthesis or delete the extra parenthesis and retry the operation.



DTFM005E  
SYNTAX ERROR IN PARAMETER *param-name*

**Recipients:** 1

**Explanation:** The syntax of the indicated parameter is incorrect.

**User Action:** The *Digital SNA Data Transfer Facility for OpenVMS Use* manual explains the correct syntax. Correct the syntax and retry the operation.

DTFM006E  
THE NODE AND ACCESS CONTROL PORTION OF *file-spec* IS TOO LONG

**Recipients:** 1

**Explanation:** The indicated non-IBM file specification contains too many characters in the node and access control portion of the file specification. The node and access control portion includes the double colons.

**User Action:** Correct the parameter and retry the operation.

DTFM007E  
*file-spec* IS MISSING THE FILE NAME PORTION

**Recipients:** 1

**Explanation:** The indicated non-IBM file specification does not contain a file name portion. The file name portion consists of everything following the node portion of the file specification.

**User Action:** Correct the parameter and retry the operation.

DTFM009E  
KEYWORD *param-name* INVALID IF INFILE UNDEFINED OR NOT IBM  
FILE

**Recipients:** 1

**Explanation:** The indicated INFILE-related parameter was specified without first defining an INFILE.

**User Action:** An INFILE is required before you can specify any INFILE-related parameters. Define the INFILE; then redefine the INFILE-related parameters.

DTFM010E

KEYWORD *param-name* INVALID IF OUTFILE UNDEFINED OR NOT IBM  
FILE

**Recipients:** 1

**Explanation:** The indicated OUTFILE-related parameter was specified without first defining an OUTFILE.

**User Action:** An OUTFILE is required before you can specify any OUTFILE-related parameters. Define the OUTFILE; then redefine the OUTFILE-related parameter.

DTFM011E

THE VALUE SPECIFIED FOR KEYWORD *keyword-name* IS NOT ACCEPTABLE

**Recipients:** 1

**Explanation:** The indicated keyword was specified with an unacceptable value.

**User Action:** The *Digital SNA Data Transfer Facility for OpenVMS Use* manual explains the correct syntax. Correct the parameter and retry the operation.

DTFM012E

THE VALUE SPECIFIED FOR KEYWORD *keyword-name* IS NOT LEGAL

**Recipients:** 1

**Explanation:** The indicated keyword was specified with unacceptable characters.

**User Action:** The *Digital SNA Data Transfer Facility for OpenVMS Use* manual explains the correct syntax. Correct the parameter and retry the operation.

DTFM013E

*file-spec* WHICH IS AN IBM FILE-SPEC, HAS A SYNTAX ERROR

**Recipients:** 1

**Explanation:** The indicated INFILE or OUTFILE was specified as an IBM file, but it contains a syntax error.

**User Action:** Correct the parameter and retry the operation.

DTFM014E

TOO MANY CHARACTERS BEFORE THE MEMBER NAME OF THE IBM  
FILE-SPEC IN PARAMETER *param-name*

**Recipients:** 1

**Explanation:** The indicated INFILE or OUTFILE was specified as an IBM file, but it contains too many characters including the member name.

**User Action:** Correct the parameter and retry the operation.

DTFM015E

MINIDISK LINK FAILED - OWNER:*owner-id* ADDRESS:*virtual-address*  
MODE:*link-mode*

**Recipients:** 1

**Explanation:** This message is issued if the minidisk involved in the transfer could not be linked for some reason. The transfer is rejected and the user is returned to the prompt.

**User Action:** Examine the indicated minidisk owner, device address, and minidisk password to make sure that they are all correct. In addition, there may be VM messages indicating the reason for the failure.

DTFM016E

INFILE AND OUTFILE BOTH LOCAL FILES - UNSUPPORTED

**Recipients:** 1

**Explanation:** This message is issued if both files for the transfer are determined to be local. DTF does not support file transfers where both files are on the local system.

**User Action:** If this is not a user error then check the input to the transfer to determine if a node name has been supplied for the network file.

DTFM017E

DTF HELP FILES NOT FOUND

**Recipients:** 1

**Explanation:** An installation error has caused the DTF help files to be inaccessible.

**User Action:** Review the installation of DTF to make sure that the help files were placed on a minidisk accessible to your user ID.

DTFM018E

LOST INTERCONNECTION TO NETMGR: *component-name*

**Recipients:** 1

**Explanation:** This message is issued when the conversation with the DTF Network Manager is unexpectedly dropped. This is due either to a failure in the network connection to the network or to a failure of the virtual machine. The *component-name* value is the name of the DTF Network Manager.

**User Action:** Check to see if the Network Manager is still operative. If the Network Manager is still operative, then check the log files to determine the cause of the failure.

DTFM019E

TAPE REQUEST CANCELLED

**Recipients:** 1

**Explanation:** This message is issued when the IBM interface user issues the CANCEL command after a tape mount request has been sent to the user ID specified in TAPEOPER. The TAPEOPER user ID is notified that the tape request has been cancelled and control is returned to the command processor.

**User Action:** Restart request if desired.

DTFM020S

ESTAE ENVIRONMENT COULD NOT BE CREATED

**Recipients:** 1

**Explanation:** The DTF command processor failed to initialize the internal recovery routine. This is a fatal error that terminates the DTF command processor and returns control to the user. This is most likely a software error.

**User Action:** Chapter 3 explains how to collect information and report problems.

DTFM021S

THE TSO PARAMETERS TABLE COULD NOT BE LOADED

**Recipients:** 1

**Explanation:** The DTF command processor could not locate the TSO parameter table load module at initialization time. This is an installation error.

**User Action:** Locate the installation job that created the TSO parameters table. Make sure that the load module was placed in a data set that is

accessible by the TSO user.

**DTFM022S**

THE VALUE SPECIFIED FOR THE MODE KEYWORD IS NOT RECOGNIZED

**Recipients:** 1

**Explanation:** The ISPF panels were damaged; DTF can no longer be accessed from ISPF. This is an installation error.

**User Action:** Reinstall the ISPF portion of DTF.

**DTFM023S**

NO MEMORY AVAILABLE FOR INITIALIZATION

**Recipients:** 1

**Explanation:** The DTF command processor could not allocate enough internal memory to initialize successfully.

**User Action:** Increase the region size for the user or the batch JCL and resubmit the command.

**DTFM024I**

TAPE REQUEST SENT TO *user-id*

**Recipients:** 1

**Explanation:** An informational message indicating which user ID was sent the tape mount request message as a result of your initiating a transfer to or from tape.

**User Action:** Informational. No action is necessary.

**DTFM030I**

REQUEST SUBMITTED TO *subsystem-name*

**Recipients:** 1

**Explanation:** The request was submitted to the indicated subsystem identified in this message. The user is placed in a waiting state until the subsystem reports that the transfer is complete. You can exit from the waiting state and cancel the request by using the CANCEL option.

**User Action:** Informational. No action is necessary.

DTFM031I  
DTF ENTERING WAIT STATE

**Recipients:** 1

**Explanation:** The user is in a waiting state until the subsystem reports that the transfer is complete. You can exit from the waiting state and cancel the request by using the CANCEL option.

**User Action:** Informational. No action is necessary.

DTFM032I  
CANCEL REQUEST SUBMITTED TO *subsystem-name*

**Recipients:** 1

**Explanation:** The user requested a cancel. The indicated subsystem was notified of the request.

**User Action:** The user can either continue using DTF commands or stop the DTF command processor.

DTFM033I  
CROSS MEMORY AUTHORIZATION STILL SET

**Recipients:** 1

**Explanation:** The TSO user is trying to clean up from a DTF request, but the cross memory authorization cannot be removed from the subsystem. This is a software error.

**User Action:** Since the TSO user's memory can be written over by the subsystem, the safest course is to log off and log on again. Chapter 3 explains how to collect information and report problems.

DTFM034E  
SUBSYSTEM *subsystem-name* REPORTS AN ERROR BUT DOES NOT  
RETURN A MESSAGE

**Recipients:** 1

**Explanation:** The indicated subsystem completed the request with an error but did not report a DTF-related condition. The transfer did not complete successfully. The server node, not the DTF subsystem, is probably the source of the error.

**User Action:** Check for OpenVMS messages that report the reason for the failure.

DTFM035E

SERVER *server-name* REPORTS AN ERROR BUT DOES NOT RETURN A MESSAGE

**Recipients:** 1

**Explanation:** The indicated server completed the request with an error but did not return any messages. This condition is most likely due to a problem with the OpenVMS/DTF software.

**User Action:** Chapter 3 explains how to collect information and report problems.

DTFM036I

SUBSYSTEM *subsystem-name* STILL PROCESSING REQUEST

**Recipients:** 1

**Explanation:** The timer expired without the indicated subsystem responding.

**User Action:** Informational. No action is necessary. This is a normal message that is written every 90 seconds while a TSO request is pending.

DTFM037I

THIS REQUEST ASSIGNED REQUEST NUMBER *request-number*

**Recipients:** 1

**Explanation:** The subsystem assigned the indicated request number to you. Error tracing is done with this number.

**User Action:** Informational. No action is necessary.

DTFM038E

ERROR HANDLING TERMINAL INTERRUPT ENVIRONMENT

**Recipients:** 1

**Explanation:** An internal error caused DTF to miss a terminal interrupt. This is a fatal error. The subsystem is notified of a user failure and the transfer is aborted. This is a DTF for IBM software error.

**User Action:** Chapter 3 explains how to collect information and report problems.

DTFM039E

SUBSYSTEM *subsystem-name* HAS SHUTDOWN WITHOUT REPORTING STATUS OF REQUEST

**Recipients:** 1

**Explanation:** The indicated subsystem shut down unexpectedly and was unable to notify all users of the system failure. The transfer state can be determined through OpenVMS reporting logs.

**User Action:** Your IBM system staff must restart the DTF Network Manager subsystem. When it becomes active, retry the request.

DTFM040E

SUBSYSTEM NAME *subsystem-name* IS NOT DEFINED

**Recipients:** 1

**Explanation:** The indicated subsystem is not defined.

**User Action:** Correct the subsystem name parameter and retry the request.

DTFM041E

SUBSYSTEM *subsystem-name* IS NOT ACTIVE

**Recipients:** 1

**Explanation:** The indicated subsystem is not currently active.

**User Action:** Your IBM system staff must start the DTF Network Manager subsystem.

DTFM042E

SUBSYSTEM *subsystem-name* IS NOT CAPABLE OF HANDLING THIS REQUEST

**Recipients:** 1

**Explanation:** The indicated subsystem is not a DTF subsystem.

**User Action:** Correct the subsystem name and reissue the request.

DTFM043E

SUBSYSTEM *subsystem-name* IS BUSY, RESUBMIT REQUEST AT A LATER TIME

**Recipients:** 1

**Explanation:** The indicated subsystem is busy. The request cannot be processed.

**User Action:** Resubmit the request at a later time.



**MVS** If this error occurs frequently, increase the space allocated for the TSO request.

DTFM044E

ERROR ESTABLISHING CROSS MEMORY ACCESS TO *subsystem-name*

**Recipients:** 1

**Explanation:** The indicated subsystem cannot be contacted with the request because of cross memory failure. This is a DTF for IBM software error.

**User Action:** Chapter 3 explains how to collect information and report problems.

DTFM045E

COULD NOT LOAD REQUIRED MODULE: *module-name*

**Recipients:** 1

**Explanation:** The indicated module could not be loaded from the DTF command processor. DTF cannot initialize without the module. This is a DTF for IBM installation error.

**User Action:** Make sure that the module named is accessible to this user.

DTFM046E

MISSING REQUIRED KEYWORD: *param-name*

**Recipients:** 1

**Explanation:** A request missing the indicated keyword is rejected without reaching the subsystem.

**User Action:** Define the missing parameter and resubmit the request.

DTFM047I

DTF

**Recipients:** 1

**Explanation:** This is the short form of the DTF command processor prompt. DTF is ready to accept any valid command.

**User Action:** Informational. No action is necessary.

DTFM048I

ENTER CLEAR, DEFINE, END, LIST, RECALL, RESUME, SET, SHOW, OR  
TRANS

**Recipients:** 1

**Explanation:** This is the long form of the DTF command processor prompt. DTF is ready to accept any valid command.

**User Action:** Informational. No action is necessary.

DTFM049E

SYNTAX ERROR IN COMMAND *command*

**Recipients:** 1

**Explanation:** The indicated DTF command contains a syntax error.

**User Action:** The *Digital SNA Data Transfer Facility for OpenVMS Use* manual explains the correct syntax. Correct the command and retry the operation.

DTFM050E

COMMAND *command* IS NOT RECOGNIZED

**Recipients:** 1

**Explanation:** The indicated DTF command is not recognized.

**User Action:** The *Digital SNA Data Transfer Facility for OpenVMS Use* manual explains the correct syntax. Correct the command and retry the operation.

DTFM051W

KEYWORD *param-name* IGNORED BECAUSE INFILE IS NOT AN IBM  
FILE-SPEC

**Recipients:** 1

**Explanation:** The indicated keyword cannot be specified if the INFILE is not an IBM file specification.

**User Action:** Informational. No action is necessary. The parameter is ignored.

DTFM052W

KEYWORD *param-name* IGNORED BECAUSE OUTFILE IS NOT AN IBM FILE-SPEC

**Recipients:** 1

**Explanation:** The indicated keyword cannot be specified if the OUTFILE is not an IBM file specification.

**User Action:** Informational. No action is necessary. The parameter is ignored.

DTFM053E

*file-spec* WHICH IS A NON-IBM FILE-SPEC, HAS A SYNTAX ERROR

**Recipients:** 1

**Explanation:** The indicated INFILE or OUTFILE, specified as an OpenVMS file specification, contains a syntax error.

**User Action:** Correct the syntax and resubmit the command.

DTFM054E

UNABLE TO PROMPT FOR MISSING PASSWORD BECAUSE PROFILE SET TO NOPROMPT

**Recipients:** 1

**Explanation:** The DTF command processor is trying to prompt for a missing password, but the TSO profile is set to NOPROMPT.

**User Action:** Define the missing passwords and resubmit the request. The next time you invoke DTF, set your TSO profile to PROMPT to allow the TSO command processor to prompt for the missing password in a nondisplay field.

DTFM055I

SUBSYSTEM *subsystem-name* REPORTS COMPLETION OF REQUEST

**Recipients:** 1

**Explanation:** The indicated subsystem has completed your request. Examine the messages or the return code for information about the success or failure of the request.

**User Action:** Informational. No action is necessary.

DTFM056I

SERVER *server-name* REPORTS SUCCESS

**Recipients:** 1

**Explanation:** The indicated server successfully completed your request. OpenVMS messages may be returned.

**User Action:** Informational. No action is necessary.

DTFM057E

SUBSYSTEM *subsystem-name* IS NOT ACCEPTING REQUESTS

**Recipients:** 1

**Explanation:** The indicated subsystem is in shutdown mode. The request cannot be resubmitted.

**User Action:** Retry the request later.

DTFM058S

INTERNAL ERROR IN DTF

**Recipients:** 1

**Explanation:** An internal error forced the DTF command processor to terminate. This is a DTF for IBM software error.

**User Action:** Chapter 3 explains how to collect information and report problems.

DTFM060E

*keyword-name* IBM FILE-SPEC QUALIFIER OR MEMBER NAME MUST BEGIN WITH ALPHA

**Recipients:** 1

**Explanation:** The IBM file specification was entered improperly. Qualifiers and member names must begin with an alphabetic character.

**User Action:** Reissue the DEFINE subcommand with the correct INFILE or OUTFILE specification.

DTFM061E

*keyword-name* GDG VALUE IN IBM FILESPEC IS INVALID

**Recipients:** 1

**Explanation:** The IBM file specification was entered improperly. A keyword describing a generation data group (GDG) has been entered improperly.

**User Action:** Reissue the DEFINE subcommand with the correct INFILE or OUTFILE specification.

DTFM062I

THIS REQUEST ASSIGNED RETRY NUMBER *retry-number*

**Recipients:** 1

**Explanation:** The client node assigned the transfer request the indicated retry number. This message is seen only if the request is executed in recoverable mode. If the transfer fails with a recoverable error, the *retry-number* value can be used as the retry number (or RETNUM keyvalue) when the transfer is resumed.

**User Action:** Informational. No action is necessary.

DTFM063C

THE TSO PARAMETERS TABLE IS NOT IN THE PROPER FORMAT

**Recipients:** 1

**Explanation:** The TSO parameters table is not in the proper format for this release of the DTF command processor. The DTF command processor will terminate without processing any commands.

**User Action:** Verify that the TSO parameters table was properly installed into a STEPLIB or system library that is available to the job issuing the DTF command.

DTFM064E

THE ACCESS CONTROL PORTION OF *file-spec* HAS A SYNTAX ERROR

**Recipients:** 1

**Explanation:** The access control portion of the DECnet file specification contains a syntax error. All keywords associated with the INFILE or OUTFILE that contains the errors will be ignored until the corrected INFILE or OUTFILE is defined with the DEFINE subcommand.

**User Action:** Verify the syntax rules for DECnet file specifications and reenter the command.

DTFM065W

CONFLICTING VALUES FOR *keyword-name/keyword-name* - THE SECOND ONE IS IGNORED

**Recipients:** 1

**Explanation:** The value specified for the second keyword in the text of the message conflicts with the value specified for the first keyword. The value of the second keyword is ignored.

**User Action:** Change the value entered for the first keyword, then redefine the second keyword.

DTFM066I  
THE RECOVERABLE COPY REQUEST IS ABOUT TO BEGIN

**Recipients:** 1

**Explanation:** A client node has been contacted and has accepted the recoverable transfer request. The series of messages that follows reports all of the information required to retry the transfer, should it fail.

**User Action:** Informational. No action is necessary.

DTFM067I  
SERVER NODE HANDLING THE TRANSFER IS *server-name*

**Recipients:** 1

**Explanation:** The indicated server node is being used by the DTF Network Manager to control the transfer. The server node name is relevant only if the transfer involves two IBM files.

**User Action:** If the transfer involves two IBM files, save the name of the server.

DTFM068I  
CLIENT NODE INVOLVED IN TRANSFER IS *client-name*

**Recipients:** 1

**Explanation:** The indicated client node is actually performing the transfer. This information is required to resume a failed transfer.

**User Action:** Save the name of the client node.

DTFM069E  
DTF SVC INCAPABLE OF HANDLING REQUEST, VERSION MISMATCH

**Recipients:** 1

**Explanation:** This is normally an installation error where the new DTF interfaces are using a previous version of the DTF SVC. The DTF SVC cannot handle the request because of a version mismatch on the request block.

**User Action:** Install a new version of the DTF SVC to correct this problem.

DTFM070W

SYNTAX ERROR IN PREVIOUS LINE OR PARSER ERROR HAS CAUSED  
PREVIOUS INPUT TO BE IGNORED

**Recipients:** 1

**Explanation:** The parser discarded an input line or an unexpected parser error occurred. This error usually occurs when you enter too many characters within the parentheses of a keyvalue. All of the remaining line is discarded.

**User Action:** Correct the keyvalue that caused the previous error. If you entered multiple keywords and keyvalues on the line, reenter all of the keywords and keyvalues.

DTFM071E

DTFSEND FAILED

**Recipients:** 1

**Explanation:** This error is issued if DTF attempts to send a request to the Network Manager and fails. The transfer is terminated.

**User Action:** Check that the Network Manager virtual machine is logged on and available.

DTFM081I

DTF USER STARTUP USING PARMS FILE: *file-name*

**Recipients:** 1

**Explanation:** Report of which DTFUSER parameter file was used. During startup of the DTF user interface the file DTFUSER PARMS is read to configure options relating to IBM-initiated transfers. The first file by this name found in the minidisk search order is the one that will be used. This allows one common copy of DTFUSER PARMS to be used, or all users could have their own copy.

**User Action:** Informational. No action is necessary.

DTFM082I

VALUE FOR KEYWORD *keyword-name* INVALID.

**Recipients:** 1

**Explanation:** While parsing the DTFUSER PARMS file the indicated keyword was found with an invalid value. The default is used instead and initialization continues. DTF will function normally using the defaulted keyword.

**User Action:** Correct the invalid keyword if desired.

DTFM085E

KEYWORD *keyword-name* IS NOT RECOGNIZED

**Recipients:** 1

**Explanation:** The indicated keyword is not valid. The incorrect keyword is ignored.

**User Action:** Correct the offending keyword.

DTFM086E

VALUE SPECIFIED FOR KEYWORD *keyword-name* IS TOO LONG

**Recipients:** 1

**Explanation:** The indicated keyword was entered with a value that was too long. The keyword and its value are ignored.

**User Action:** Correct the keyword value and reenter the command.

DTFM087E

VALUE SPECIFIED FOR KEYWORD *keyword-name* IS TOO SHORT

**Recipients:** 1

**Explanation:** The indicated keyword was entered with a value that was too short. The keyword and its value are ignored.

**User Action:** Correct the keyword value and reenter the command.

DTFM088E

DATA TYPE MISMATCH FOR KEYWORD: *keyword-name*

**Recipients:** 1

**Explanation:** The indicated keyword was entered with a value that was not of the correct data type. The most common reason is entering a character value when numerics are expected. The keyword is ignored.

**User Action:** Correct the keyword value and reenter the command.

DTFM089E

DUPLICATE KEYWORD IGNORED: *keyword-name*

**Recipients:** 1

**Explanation:** The indicated keyword was entered twice on the same line. The second occurrence of the keyword is ignored.

**User Action:** Informational. No action is necessary.



DTFM090S  
SEVERE ERROR IN *portion-name* PORTION OF DTF, NO COMMANDS  
PROCESSED

**Recipients:** 1

**Explanation:** An internal error forced the DTF command processor to terminate. This is a DTF for IBM software error.

**User Action:** Chapter 3 explains how to collect information and report problems.

DTFM091I  
DETAIL QUERY REQUEST ACCEPTED

**Recipients:** 1

**Explanation:** This is the normal beginning of a set of messages in response to a QUERY command.

**User Action:** Informational. No action is necessary.

DTFM092I  
DETAIL QUERY REQUEST COMPLETED

**Recipients:** 1

**Explanation:** This is the normal termination of a set of messages in response to a QUERY command.

**User Action:** Informational. No action is necessary.

DTFM093I  
<-----*section-name* DATA ----->

**Recipients:** 1

**Explanation:** This message precedes a set of messages that describe the state of the transfer request in general. Specific information about the transfer is available in other messages. The *section-name* variable can contain one of the following three values:

REQUEST	This message will be followed by messages describing a transfer initiated by an IBM user.
TRANSFER	This message will be followed by messages describing a transfer in progress.
FILE	This message will be followed by messages describing a local file involved in a transfer.

**User Action:** Informational. No action is necessary.

DTFM094I

NET PATH : LU(*vtam-lu-name*) ACCESS(*dtf-access-number*)

**Recipients:** 1

**Explanation:** This message shows the names of the network resources used for the transfer.

**User Action:** Informational. No action is necessary.

DTFM095I

NO *resource-name* AVAILABLE

**Recipients:** 1

**Explanation:** It is possible that the transfer has not yet begun or has already completed, in which case there is no detailed information available. The *resource-name* variable is replaced by one of the following:

- IUCV/APPC COUNTS      No IUCV or APPC connection has yet been started to handle the transfer.
- FILE COUNTS            The local file has not yet been opened for the transfer.
- FILE INFO                The local file has not yet been identified.
- TRANSFER COUNTS      The transfer has not yet begun.

**User Action:** Informational. No action is necessary.

DTFM096I

*count-type* COUNTS: TYPE(*count-subtype*) TOTAL(*total-number*) BYTE(*number-of-bytes*) MBYTE(*number-of-mbytes*)

**Recipients:** 1

**Explanation:** This message shows the counters for the various resources being used.

<i>count-type</i>	<i>count-subtype</i>	<i>total-number</i>	<i>number-of-bytes</i>	<i>number-of-mbytes</i>
IUCV	SEND	number of IUCV sends	number of bytes sent	number of megabytes sent
IUCV	RECV	number of IUCV receives	number of bytes received	number of megabytes received
APPC	SEND	number of APPC sends	number of bytes sent	number of megabytes sent
APPC	RECV	number of APPC receives	number of bytes received	number of megabytes received

<i>count-type</i>	<i>count-subtype</i>	<i>total-number</i>	<i>number-of-bytes</i>	<i>number-of-mbytes</i>
VTAM	SEND	number of VTAM sends	number of bytes sent	number of megabytes sent
VTAM	RECV	number of VTAM receives	number of bytes received	number of megabytes received
FILE	READ	number of file reads	number of bytes read	number of megabytes read
FILE	WRITE	number of file writes	number of bytes written	number of megabytes written

**User Action:** Informational. No action is necessary.

DTFM097I

DTF WORK UNITS: ACCESS(*dtf-access-number*) RETRY NUMBER(*retry-number*)

**Recipients:** 1

**Explanation:** This message, which is displayed in response to a detailed query on an IBM-initiated transfer, shows the DTF work units associated with the transfer:

*dtf-access-number*      the access number which is the local unit of work

*retry-number*          the retry number assigned by the client system during a recoverable file transfer

**User Action:** Informational. No action is necessary.

DTFM098I

DTF SERVICES: NETMGR(*manager-name*) V(*manager-version*) SERVER(*server-name*) V(*server-version*)

**Recipients:** 1

**Explanation:** This message, which is displayed in response to a detailed query on an IBM-initiated transfer, shows DTF service providers for the two networks.

*manager-name*          the DTF Network Manager subsystem providing DTF services

*manager-version*      the version number of the DTF Network Manager software

*server-name*            the OpenVMS/DTF server node providing services for the file transfer

*server-version* the version number of the OpenVMS/DTF server node software

**User Action:** Informational. No action is necessary.

DTFM099I

DTF SERVICES: CLIENT(*client-name*) V(*version-number*)

**Recipients:** 1

**Explanation:** This message, which is displayed in response to a detailed query on an IBM-initiated transfer, shows the DTF client involved in the transfer and its version number, if available.

**User Action:** Informational. No action is necessary.

DTFM100I

FILE ACCESS:*file-info*

**Recipients:** 1

**Explanation:** This message, which is displayed in response to a detailed query on an IBM-initiated transfer, shows the local file being accessed and, if possible, information about how the file is being used.

**User Action:** Informational. No action is necessary.

DTFM101I

SUCCESSFUL TRANSFER - RECORD COUNT IS *number-transferred*

**Recipients:** 1

**Explanation:** This message, which is displayed upon successful completion of a file transfer, shows the number of records that were transferred during the file transfer.

**User Action:** Informational. No action is necessary.

DTFM102I

*section-name* DATA:

**Recipients:** 1

**Explanation:** This message precedes a set of messages that describe the state of the transfer request in general. Specific information about the transfer is available in other messages. The *section-name* variable can contain one of the following three values:

REQUEST This message will be followed by messages describing a transfer initiated by an IBM user.

TRANSFER This message will be followed by messages describing a transfer in progress.

FILE                    This message will be followed by messages describing a local file involved in a transfer.

**User Action:** Informational. No action is necessary.

DTFM103I  
USER NOW IN *mode* MODE

**Recipients:** 9

**Explanation:** This message is displayed in response to a TSO user invoking the WAIT or QUERY option during a transfer. The message indicates that the requested mode has been entered. In WAIT mode the keyboard will remain locked until the transfer completes. In QUERY mode the display will be refreshed every 5 seconds to show the status of the transfer.

**User Action:** Informational. No action is necessary.

DTF0100I  
INITIALIZATION COMPLETE FOR DATA TRANSFER FACILITY COMPONENT  
*component-name*

**Recipients:** 1

**Explanation:** This message is displayed after a DTF component has completed its initialization and is ready for use. The *component-name* variable is replaced by one of the following:

MVS NODE MANAGER	the component that provides node, network, and file services on an MVS client.
GCS NETWORK MANAGER	the component that provides network management services on a VM client.
CMS NODE MANAGER	the component that provides node and file management on a VM client.

**User Action:** Informational. No action is necessary.

DTF0101I  
TASK ID *subtask* IS INITIALIZED

**Recipients:** 1

**Explanation:** The indicated subtask is reporting successful initialization.

**User Action:** Informational. No action is necessary.

DTF0102C

INITIALIZATION OF TASK ID *subtask* FAILED WITH REASON CODE =  
*X"reason-code"* WHICH MEANS: *reason-text*

**Recipients:** 0

**Explanation:** The indicated subtask failed to initialize. This subtask is critical to the function of DTF. DTF immediately shuts down with a return code of 112 for the job step.

**User Action:** This error generally requires a system programmer's attention. Report the number within the quotation marks to your system programmer.

---

<i>reason-code</i>	<b>Explanation</b>	<b>User Action</b>
00000004	DTF is having memory problems.	Increase the region for this job step.
00000008	DTF is having memory problems. The events table is allocated out of LSQA storage.	Your installation may have to increase the LSQA so that DTF can successfully initialize.
00000012	The security environment requested cannot be established.	Check the DTF Network Manager software installation for the module name of the security exit. Make sure that this module is available to the DTF Network Manager.

---

DTF0103I

SUBSYSTEM INTERFACE NOT CONFIGURED

**Recipients:** 1

**Explanation:** DTF did not activate the subsystem interface because it was not selected in the startup parameters.

**User Action:** Informational. No action is necessary.

DTF0104C

PROGRAM NOT AUTHORIZED, STARTUP CANCELED

**Recipients:** 1

**Explanation:** The DTF component failed during initialization because it was not authorized. This is an installation error.

**User Action:** MVS Either APF-authorize the STEPLIB data set for the DTF Node Manager job or copy the DTF Node Manager load modules to an

APF-authorized system library.

**User Action:**  Grant the Network Manager access to the VTAM software using the GCS AUTHORIZE macro. For detailed instructions on using the AUTHORIZE macro, refer to the *Group Control System Command and Macro Reference* manual.

DTF0105I

LOGGING EXIT MODULE *module-name* LOADED AND ACTIVATED

**Recipients:** 1

**Explanation:** The DTF component successfully activated the indicated logging exit.

**User Action:** Informational. No action is necessary.

DTF0106I

LOGGING EXIT IS NOT CONFIGURED, LOGGING IS NOT ACTIVATED

**Recipients:** 1

**Explanation:** The DTF component will run without the logging exit.

**User Action:** Informational. No action is necessary.

**Note:** The logging function can be specified by including a logging module name during DTF for IBM software installation.

DTF0107W

LOGGING EXIT MODULE *module-name* WAS NOT FOUND, LOGGING IS NOT ACTIVATED

**Recipients:** 1

**Explanation:** The DTF component tried to load the indicated logging exit but the exit was not found. The subsystem continues with the initialization but does not activate the logging function.

**User Action:** Stop the DTF component and take one of the following actions:

- Correct the name of the logging exit module used during DTF for IBM software installation.
- Make sure that the logging exit is either in a system library or in the DTF component STEPLIB library.

DTF0108I

DTF START DATE: *date* START TIME: *time*

**Recipients:** 1

**Explanation:** This message indicates the startup date and time.

**User Action:** Informational. No action is necessary.

DTF0109E

DTF NOT AUTHORIZED - ATTEMPTING TO RUN IN UNAUTHORIZED  
MODE

**Recipients:** 1

**Explanation:** DTF is not authorized to issue special commands.

**User Action:** Informational. No action is necessary.

DTF0110I

DTF *control-block-name* IS @ *location*

**Recipients:** 1

**Explanation:** The indicated control block is at the indicated location.

**User Action:** Informational. No action is necessary.

DTF0111W

UNABLE TO ALLOCATE PROXY FILE, DEFAULT PROXY ACCESS  
DISABLED, DYNALLOC ERR=

**Recipients:** 1

**Explanation:** The NODEPARMS startup file had a PROXYDSN value coded but a problem was encountered attempting to allocate the file.

**User Action:** It is possible that the file does not exist if the failure-code is 1708. Review the startup options and installation documentation to determine if the file is required.

DTF0112W

UNABLE TO OPEN PROXY FILE, DEFAULT PROXY ACCESS DISABLED

**Recipients:** 1

**Explanation:** The PROXYDSN file was successfully allocated but could not be opened.

**User Action:** The PROXYDSN file should be a sequential file with a record size of 80. If this is incorrect then delete and reinitialize, and restart DTF.



DTF0113W

PROXY IS SET TO ON BUT PROXYEXIT NOT SPECIFIED. PROXY HAS BEEN DISABLED.

**Recipients:** 1

**Explanation:** In order to set PROXY(ON) the PROXYEXIT value must also be coded.

**User Action:** Review the installation and set PROXY to OFF or install the PROXYEXIT.

DTF0114W

ERROR LOADING PROXYEXIT. PROXY HAS BEEN DISABLED.

**Recipients:** 1

**Explanation:** The PROXYEXIT could not be loaded. In order to set PROXY(ON), PROXYEXIT must be available.

**User Action:** Review the installation and set PROXY to OFF or install the PROXYEXIT.

DTF0115I

DEFAULT FOR *parameter-name* IS NOW SET TO *value*

**Recipients:** 1

**Explanation:** This message may be displayed when you override a parameter in the startup process. Not all DTF components issue this message.

**User Action:** Informational. No action is necessary.

DTF0116W

DEFAULT OVERRIDE FOR *parameter-name* VALUE *value* IS INVALID AND IGNORED

**Recipients:** 1

**Explanation:** The value you specified to override the default value is invalid. The default value is not overridden.

**User Action:** Correct the parameter and restart the DTF component.

DTF0120E

PARAMETER ERROR, "*param-name*" is unknown.

**Recipients:** 1

**Explanation:** The indicated parameter is invalid.

**User Action:** Correct the error and restart DTF.

DTF0121E  
DATA FOLLOWING KEYWORD "*keyword-name*" IS MISSING

**Recipients:** 1

**Explanation:** The indicated keyword was encountered without a related data value.

**User Action:** Correct the error and restart DTF.

DTF0130C  
CREATION OF TASK ID *task-name* FAILED BECAUSE NO MEMORY  
AVAILABLE FOR THE SUBTASK TABLE ELEMENT

**Recipients:** 0

**Explanation:** DTF failed during initialization. A return code of 112 is returned from the job step.

**User Action:** Increase the region size for this job step.

DTF0131C  
CREATION OF TASK ID *task-name* FAILED BECAUSE THE PROGRAM  
COULD NOT BE ATTACHED

**Recipients:** 0

**Explanation:** DTF failed during initialization. A return code of 112 is returned from the job step, indicating that DTF cannot locate the required program.

**User Action:** Check your installation steps to make sure that all required load modules are available at run time.

DTF0132C  
CREATION OF TASK ID *task-name* FAILED BECAUSE THE PROGRAM  
*program-name* COULD NOT BE LOADED

**Recipients:** 0

**Explanation:** The DTF component has failed during initialization. A return code of 112 is returned from the job step.

**User Action:** This is an installation error. The DTF component cannot locate the required program. Check your installation steps to make sure that all required load modules are available at run time.

DTF0150C

VTAM INITIALIZATION FAILED DUE TO MEMORY PROBLEMS WHILE  
SETTING UP A *control-block-name*

**Recipients:** 0

**Explanation:** The indicated VTAM control block could not be created during initialization.

**User Action:** Increase the region size and restart the job.

DTF0152C

VTAM ACB OPEN FOR APPLID *application-id* FAILED WITH R15/ERROR  
CODE = X"*reason-code*" WHICH MEANS: *reason-text*

**Recipients:** 1

**Explanation:** DTF failed during initialization. A return code of 142 is returned from the job step.

**User Action:** This error generally requires a system programmer's attention. Report the indicated reason code to your system programmer.

**Note:** The first 4 digits of the *reason-code* number are the value in register 15 on return from the OPEN macro. The second 4 digits of the number contain the error code from the VTAM ACB.

---

<i>reason-code</i>	Explanation	User Action
00080058	The APPLID is being used by another job.	Change the application ID (APPLID) in the initialization options and resubmit the job. Otherwise you must wait for the current job to release the APPLID.
00080070	The APPLID belongs to another job but it is closed.	Change the application ID (APPLID) in the initialization options and resubmit the job. Otherwise you must wait for the current job to release the APPLID.
000C005A	The VTAM APPLID was not defined to VTAM.	Check the network definition of the application ID (APPLID). This error can also occur if you failed to activate the APPLID.

---

DTF0153C

VTAM INITIALIZATION FAILED DUE TO BAD RETURN FROM *control-block-name* GENCB

**Recipients:** 0

**Explanation:** An internal logic error has caused an error during the generation of the indicated VTAM control block. This is a DTF for IBM software error.

**User Action:** Chapter 3 explains how to collect information and report problems.

DTF0155C

VTAM INITIALIZATION FAILED WHEN LOGONS ENABLED

**Recipients:** 0

**Explanation:** An internal logic error caused an error return from the SETLOGON macro. VTAM does not allow unsolicited sessions without this macro succeeding. Therefore, VTAM initialization failed and DTF shut down with a return code of 142. This is a DTF for IBM software error.

**User Action:** Chapter 3 explains how to collect information and report problems.

DTF0156I

VTAM INTERFACE STARTED USING APPLID *application-id*

**Recipients:** 1

**Explanation:** This message is issued after the VTAM ACB is successfully opened. The *application-id* variable is replaced by the application ID supplied during DTF for IBM software installation or through startup parameters.

**User Action:** Informational. No action is necessary.

DTF0161I

SUBSYSTEM NAME *subsystem-name* IS BEING USED BY DTF

**Recipients:** 1

**Explanation:** The indicated subsystem interface has been initialized.

**User Action:** Informational. No action is necessary.

DTF0162S

MEMORY FAILURE DURING SUBSYSTEM INTERFACE INITIALIZATION

**Recipients:** 1

**Explanation:** DTF could not get enough memory to initialize the subsystem interface.

**User Action:** Increase the region size and retry the job.

DTF0163S

SUBSYSTEM NAME *subsystem-name* IS NOT DEFINED TO MVS

**Recipients:** 1

**Explanation:** DTF cannot initialize with the indicated subsystem name because MVS cannot match it in the subsystem names table.

**User Action:** Recheck the installation materials to verify the following:

- The name in the message was added to the subsystem names table.
- MVS was restarted after the change.

DTF0164S

SUBSYSTEM NAME *subsystem-name* IS ALREADY STARTED

**Recipients:** 1

**Explanation:** DTF cannot initialize with the indicated subsystem name because MVS already has an active subsystem with that name.

**User Action:** Correct the name or stop the DTF system that is using the subsystem name.

DTF0165S

NO CSA STORAGE FOR SUBSYSTEM INTERFACE INITIALIZATION

**Recipients:** 1

**Explanation:** DTF could not get required memory in the common system area (CSA).

**User Action:** Either change the MVS initialization parameters to free more CSA, or change the DTF initialization parameters to reduce the CSA requirements.

DTF0166S

DTF DENIED CROSS MEMORY AUTHORIZATION

**Recipients:** 1

**Explanation:** DTF could not get cross memory authorization as required by the subsystem interface. This error is unexpected. It could signal one of the following:

- A software problem with DTF
- A software installation-related error
- Unsupported hardware or software at the site

**User Action:** Chapter 3 explains how to collect information and report problems.

DTF0167S

DTF UNABLE TO START VTAM INTERFACE FOR SERVER SESSIONS

**Recipients:** 1

**Explanation:** DTF failed while initializing the VTAM interface to be used for server sessions. This error is unexpected. It could signal one of the following:

- A software problem with DTF
- A software installation-related error
- Unsupported hardware or software at the site

**User Action:** Chapter 3 explains how to collect information and report problems.

DTF0180I

DTF VM NODENAME = '*node-name*'

**Recipients:** 1

**Explanation:** DTF reads the site SYSTEM NETID file to determine the VM node name. The site DTF administrator must make this file available to DTF at initialization time. This file usually resides on the system volume, but DTF will use the first one it finds in its search order.

**User Action:** None required.

DTF0181C

DTF CANNOT LOCATE SYSTEM NETID FILE, SYSTEM SHUTDOWN

**Recipients:** 1

**Explanation:** DTF reads the site SYSTEM NETID file to determine the VM node name. The site DTF administrator must make this file available to DTF at initialization time. This file usually resides on the system volume, but DTF will use the first one it finds in its search order.

**User Action:** Provide access to the SYSTEM NETID file. Restart the system.

DTF0182C

DTF CANNOT MATCH THE CPUID TO AN ENTRY IN THE SYSTEM NETID FILE, SYSTEM SHUTDOWN

**Recipients:** 1

**Explanation:** DTF reads the site SYSTEM NETID file to determine the VM node name. The site DTF administrator must make this file available

to DTF at initialization time. This file should reside on the system volume, but DTF will use the first one it finds in its search order.

**User Action:** Correct the CPUID value and restart the system.

DTF0200I

SESSION ESTABLISHED WITH LU *vtam-lu-name* ACCESS NUMBER *dtf-access-number* AT *time*

**Recipients:** 1

**Explanation:** The VTAM session (that is used to transfer files) has started.

**User Action:** Informational. No action is necessary.

DTF0201E

ERROR REPORTED WHILE TRYING TO BIND LU *vtam-lu-name* VTAM  
RETURN CODE FEEDBACK CODE OF *feedback-code* AT *time*

**Recipients:** 0

**Explanation:** A bind has failed.

**User Action:** VTAM could not bind an LU because of an error. Check the return code and the feedback code to see why.

**Note:** The first 4 digits of the indicated feedback code are the return code from the OPNDST macro instruction. The second 4 digits are the feedback code from the same macro. Both numbers are reported in decimal format.

If this error occurs frequently, then a second line that explains these codes will be displayed. If a second line is not displayed, check the IBM *VTAM Programming* manual for the meaning of the return code and the feedback code.

DTF0202E

DTF REJECTED THE TRANSFER SESSION WITH LU *vtam-lu-name* FOR  
REASON CODE *reason-code* AT *time*

**Recipients:** 0

**Explanation:** DTF rejected a session because of invalid session parameters. Each reason code should appear with a second line explaining the error in more detail. If a second line does not appear with the reason code, this is a DTF for IBM software error.

**User Action:** The user action depends on the reason code; see the User Action column in the table that follows.

<i>reason-code</i>	<b>Explanation</b>	<b>User Action</b>
00000016	DTF cannot begin a new access because a shutdown is in progress.	Retry the access later.
00000020	An invalid session establishment request from a DECnet node was received. The session was rejected and the LU is unbound. This is either a software mismatch or a logon from an unsupported device.	Chapter 3 explains how to collect information and report problems.
00000024	A primary send pacing value of zero was specified on a session request. This is not allowed for DTF. The session was rejected.	Check the logon mode entry for this LU to ensure that the PSNDPAC value cannot default to zero.
00000028	A primary receive pacing value of zero was specified on a session request. This is not allowed for DTF. The session was rejected.	Check the VTAM APPL definition to make sure that a nonzero value is specified for the VPACING operand and that the AUTH parameter includes VPACE.
00000032	DTF cannot assign this access to a subtask. Try again later. A subtask is not available to handle the new access. This could be because all communications tasks are at the session limit.	If you receive this message often, adjust the DTF tuning parameters to allow more sessions.
00000040	A DECnet LU returned a negotiated bind response that is not within allowable session parameters. The LU is unbound. The request unit (RU) size is the only bind parameter that is negotiated. This error is probably caused by the DTF for IBM software.	Chapter 3 explains how to collect information and report problems.



<i>reason-code</i>	Explanation	User Action
00000048	The outbound RU size cannot be set to zero.	Check the LOGMODE entry for this LU to ensure that the RUSIZES value was not set to zero. The outbound RU size is contained in the second 2 digits of the RUSIZES field. The IBM manual <i>IBM VTAM Customization</i> explains the format of the RUSIZES parameter.
00000052	The inbound RU size cannot be set to zero.	Check the LOGMODE entry for this LU to ensure that the RUSIZES value is not set to zero. The inbound RU size is contained in the first 2 digits of the RUSIZES field. The IBM manual <i>IBM VTAM Customization</i> explains the format of the RUSIZES parameter.
00000072	The setting for MAXTRANSFERS has been exceeded. The server session is unbound. The indicated server node is unavailable to IBM DTF users until this situation is corrected.	Wait until other transfers have completed and retry the request. The system programmer should consider setting the value for MAXTRANSFERS higher and restarting the component.

DTF0203E

VTAM HAS REJECTED AN UNBIND REQUEST FOR LU *vtam-lu-name*  
WITH R15/R0 EQUAL TO *register-values* AT *time*

**Recipients:** 0

**Explanation:** VTAM did not attempt to unbind the indicated LU.

**User Action:** Check the value of register 15 and register 0 to see why. The LU should be varied inactive by a VTAM command to cancel the session.

**Note:** The first 4 digits of *register-values* are the value in register 15 after the CLSDST macro instruction. The second 4 digits are the value in register 0 after the CLSDST macro instruction. Both numbers are reported in hexadecimal format.

If this error occurs frequently, then a second line that explains these codes is displayed. If a second line is not displayed, check the VTAM documentation for the meaning of register 15 and register 0.

DTF0204S

TRANSFER SESSION INITIATION FOR *lu-name* ACCESS *dtf-access-number*  
FAILED BECAUSE NO IOB IS AVAILABLE FOR THE RECEIVE AT *time*

**Recipients:** 0

**Explanation:** This is a memory problem.

**User Action:** Increase the DTF region size.

**Note:** The access is terminated and the DECnet accessor is notified. No action should be necessary.

DTF0205E

VTAM HAS REJECTED A RECEIVE REQUEST FOR LU *vtam-lu-name*  
ACCESS NUMBER *dtf-access-number* WITH R15/R0 EQUAL TO *register-*  
*values* AT *time*

**Recipients:** 0

**Explanation:** VTAM refused to issue a receive for the indicated logical unit.

**User Action:** Check the value of register 15 and register 0 to see why.

**Note:** The access is terminated without notification to the DECnet accessor. This is a session failure. No action should be necessary.

The first 4 digits of *register-values* are the value in register 15 after the RECEIVE macro instruction. The second 4 digits are the value in register 0 after the RECEIVE macro instruction. Both numbers are reported in hexadecimal format.

If this error occurs frequently, then a second line is displayed to explain these codes. If a second line does not appear, check the VTAM documentation for the meaning of register 15 and register 0.

DTF0210E

NO DTF SERVICE MACHINE AVAILABLE TO HANDLE WORK FOR  
TRANSFER SESSION ON LU *vtam-lu-name* ACCESS *dtf-access-number*

**Recipients:** 0

**Explanation:** A transfer request was denied by the DTF Network Manager. A DTF Node Manager was not available to process the transfer.

**User Action:** Start a DTF Node Manager to handle the additional work load.

DTF0211S

UNABLE TO ACQUIRE MEMORY TO SERVICE TRANSFER SESSION LU  
*vtam-lu-name* ACCESS *dtf-access-number*

**Recipients:** 0

**Explanation:** A transfer session was denied because of a virtual storage shortage.

**User Action:** Increase the virtual storage for the virtual machine and restart the DTF component at a convenient time.

DTF0212E

FAILED ATTEMPT TO ASSIGN TRANSFER SESSION ON LU *vtam-lu-name*  
*name* ACCESS *dtf-access-number* TO SERVICE MACHINE *manager-name*  
REASON CODE *reason-code*

**Recipients:** 0

**Explanation:** The *manager-name* variable is the name of the DTF Node Manager processing the transfer.

**User Action:** Check the reason code in the *System Facilities for Programming* or *CP Programming Services* manual. Correct the error. Retry the transfer. If the error persists, call your system programmer for assistance.

DTF0232I

MESSAGE ARRIVED FROM NAME *application-name*, USER *user-id*,PATH  
*path-name*

**Recipients:** 1

**Explanation:** This message is issued when the APPC transfer mode is requested and the system is in DEBUG mode.

**User Action:** Informational. No action is necessary.

DTF0233I

MESSAGE TEXT *message-text*

**Recipients:** 1

**Explanation:** This message is issued when the APPC message arrives and the system is in DEBUG mode.

**User Action:** Informational. No action is necessary.

DTF0240E

VTAM HAS REJECTED AN UNBIND REQUEST FOR LU *vtam-lu-name*  
WITH R15/R0 EQUAL TO *register-values*

**Recipients:** 0

**Explanation:** VTAM did not attempt to unbind the indicated LU.

**User Action:** Check the value of register 15 and register 0 to see why. The LU should be varied inactive by a VTAM command in order to cancel the session.

**Note:** The first 4 digits of *register-values* are the value in register 15 after the CLSDST macro instruction. The second 4 digits are the value in register 0 after the CLSDST macro instruction. Both numbers are reported in hexadecimal format.

If this error occurs frequently, then a second line that explains these codes is displayed. If a second line is not displayed, check the VTAM documentation for the meaning of register 15 and register 0.

DTF0241I

LU *vtam-lu-name* ACCESS NUMBER *dtf-access-number* REPORTED  
COMPLETE, SESSION ALREADY UNBOUND AT *time*

**Recipients:** 1

**Explanation:** The access has completed and the indicated LU is released.

**User Action:** Informational. No action is necessary.

DTF0300I

*shutdown-type* SHUTDOWN IN RESPONSE TO TPEND

**Recipients:** 1

**Explanation:** DTF completes the shutdown by itself.

**User Action:** Informational. No action is necessary.

**Note:** The *shutdown-type* variable is either QUIESCED or FORCED:

- A QUIESCED shutdown stops all new sessions and waits for current accesses to be completed before shutting down.

- A FORCED shutdown stops all accesses without any warning to the accessor. The program terminates immediately.

DTF0302S

ERROR TRYING TO INVOKE IDCAMS

**Recipients:** 0

**Explanation:** A supersede request was not completed because DTF is unable to invoke IDCAMS dynamically.

**User Action:** Manually complete the supersede request. Chapter 3 explains how to collect information and report problems.

**Note:** This is usually an installation error.

DTF0304S

ERROR RENAMING FILE *file-name*

**Recipients:** 0

**Explanation:** A supersede request was not completed because the renaming of the indicated data set failed.

**User Action:** The supersede request must be completed manually. Look for messages that describe the reason for this failure.

**Note:** The *file-name* variable is replaced with the name of the new version of this file. This is the file to be renamed.

DTF0305S

UCB NOT MATCHED FOR VOLUME DURING SUPERSEDE

**Recipients:** 0

**Explanation:** A supersede request was not completed because the UCB of a volume was not found.

**User Action:** Manually complete the supersede request. Chapter 3 explains how to collect information and report problems.

**Note:** This error indicates a DTF for IBM software error.

DTF0306E

ERROR DELETING FILE *file-name*

**Recipients:** 0

**Explanation:** A supersede request was completed but the old version of the indicated file was not deleted.

**User Action:** Use the data set name listed in this message to delete the old version manually. Also check for messages describing the reason for the failure.

DTF0310S

A VTAM EXIT HAS REPORTED ERROR CODE *reason-code*

**Recipients:** 0

**Explanation:** A VTAM exit could not accomplish its purpose because of an internal problem. The error code reported is internal to DTF and is explained in more detail in the following entries. If no further explanation is found, this is a DTF for IBM software error.

**User Action:** The user action depends on the reason code; see the User Action column in the table that follows.

---

<i>reason-code</i>	Explanation	User Action
00000004	The VTAM LOGON exit could not get enough memory to allocate the basic control block for a session.	Either increase the region size or reduce the maximum number of sessions.
00000008	The VTAM LOGON exit could not get enough memory to make a copy of the bind image.	Either increase the region size or reduce the maximum number of sessions.

---

DTF0311I

DTF IN FORCED SHUTDOWN DUE TO VTAM EXIT IN DISTRESS

**Recipients:** 1

**Explanation:** DTF completes the shutdown by itself.

**User Action:** Informational. No action is necessary.

**Note:** Look for message DTF0310 to see the actual VTAM exit that reported an error.

DTF0330E

DTF REJECTED THE SESSION WITH LU *vtam-lu-name* FOR REASON CODE *reason-code*

**Recipients:** 0

**Explanation:** DTF rejected a session because of problems during session establishment. The reason codes are explained in more detail in the following entries.

**User Action:** The user action depends on the reason code; see the User Action column in the table that follows.

<i>reason-code</i>	<b>Explanation</b>	<b>User Action</b>
00000004	VTAM did not supply the LOGON exit with any user data. This could be a problem with VTAM or with the DECnet node.	Take a VTAM buffer trace of the session establishment logic. The INITSELF RU from the DECnet node should contain user data. If none is present, then this is a problem with the DECnet node configuration. If the user data is supplied, then it is most likely a problem with VTAM. Check the CINIT RU to see whether the user data is carried over from the INITSELF RU. Chapter 3 explains how to collect information and report problems.
00000008	VTAM has not supplied DTF with the parameters necessary to either accept or reject the session. You should not receive this reason code. If you do, it probably indicates a mismatch of DTF to the level of VTAM that your site is running.	Chapter 3 explains how to collect information and report problems.
00000016	This condition is caused by session requests that are received after DTF has been told to shut down. This is normal for DTF in quiesced shutdown mode. It could also occur if DTF is in forced shutdown mode.	No action is necessary.
00000020	An invalid session establishment request from a DECnet node was received. The session is rejected and the LU is unbound.	Check the configuration files of the DECnet node making the session request. If you cannot find any problems, refer to Chapter 3, which explains how to collect information and report problems.
00000024	A primary send pacing value of zero was specified on a session request. This is not allowed for DTF, and the session was rejected.	Check the LOGMODE entry used for this LU to make sure that the PSNDPAC value is not allowed to default to zero.

<i>reason-code</i>	<b>Explanation</b>	<b>User Action</b>
00000028	A primary receive pacing value of zero was specified on a session request. This is not allowed for DTF, and the session is rejected.	Check the VTAM APPL definition to make sure that a nonzero value is specified for the VPACING operand and that the AUTH parameter includes VPACE.

DTF0331E

VTAM HAS REJECTED AN UNBIND REQUEST FOR LU *vtam-lu-name* WITH R15/R0 EQUAL TO *register-values*

**Recipients:** 0

**Explanation:** VTAM refused to unbind the indicated LU.

**User Action:** Check the value of register 15 and register 0 to see why. The LU should be varied inactive by a VTAM command in order to cancel the session.

**Note:** The first 4 digits of *register-values* are the value in register 15 after the CLSDST macro instruction. The second 4 digits are the value in register 0 after the CLSDST macro instruction. Both numbers are reported in hexadecimal format.

If this error occurs frequently, then a second line that explains these codes is displayed. If no second line displays, check the VTAM documentation for the meaning of register 15 and register 0.

DTF0332E

VTAM HAS REJECTED A BIND REQUEST FOR LU *vtam-lu-name* WITH R15/R0 EQUAL TO *register-values*

**Recipients:** 0

**Explanation:** VTAM refused to bind the indicated LU.

**User Action:** Check the value of register 15 and register 0 to see why.

**Note:** A session is not established. In most cases the access can be retried.

The first 4 digits of *register-values* are the value in register 15 after the OPNDST macro instruction. The second 4 digits are the value in register 0 after the OPNDST macro instruction. Both numbers are reported in hexadecimal format.

If this error occurs frequently, then a second line that explains these codes is displayed. If a second line is not displayed, check the VTAM documentation for the meaning of register 15 and register 0.



DTF0333E

VTAM HAS REJECTED A MODCB REQUEST FOR LU *vtam-lu-name*, LU CANNOT BE UNBOUND

**Recipients:** 0

**Explanation:** VTAM refused to modify a session level control block. This indicates a logic error in the program. The indicated LU is still in session with DTF but it is marked as unusable.

**User Action:** Vary the LU inactive to release it from control of DTF. Chapter 3 explains how to collect information and report problems.

DTF0340I

LU *vtam-lu-name* HAS BEEN SUCCESSFULLY UNBOUND AT *time*

**Recipients:** 0

**Explanation:** The VTAM session has been ended.

**User Action:** Informational. No action is necessary.

DTF0341E

ERROR REPORTED WHILE TRYING TO UNBIND LU *vtam-lu-name* VTAM RETURN CODE / FEEDBACK CODE OF *feedback-code* AT *time*

**Explanation:** VTAM could not unbind the indicated LU due to some error.

**User Action:** Check the return code and the feedback code to see why.

**Note:** The LU should be varied inactive by a VTAM command to cancel the session.

The first 4 digits of *feedback-code* are the return code from the CLSDST macro instruction. The second 4 digits are the feedback code from the same macro. Both numbers are reported in decimal format.

If this error occurs frequently, then a second line that explains these codes is displayed. If a second line is not displayed, check the IBM *VTAM Programming* manual for the meaning of the return code and the feedback code.

DTF0391I

DROPPED INTERCONNECTION TO *user-id* AT *node-name*, ACCESS *dtf-access-number*

**Recipients:** 1

**Explanation:** A communication link to the indicated user at the indicated node has been dropped.

**User Action:** Informational. No action is necessary.

DTF0392I

TRANSFER SESSION ON *vtam-lu-name* HAS DROPPED AN INTER-  
CONNECTION TO *node-name* AT *dtf-access-number*

**Recipients:** 1

**Explanation:** A communication link to the indicated node has been dropped.

**User Action:** Informational. No action is necessary.

DTF0393I

TRANSFER SESSION ON *vtam-lu-name* ACCESS *dtf-access-number* IS  
BEING UNBOUND FOR REASON CODE *reason-code*

**Recipients:** 0

**Explanation:** The IUCV/APPC connection used by the indicated transfer has been dropped. The DTF Network Manager unbinds the LU to signal that the connection to the Node Manager or command processor has been dropped.

**User Action:** For the Network Manager this is not necessarily a problem. You must check with the Node Manager or command processor to see why the IUCV/APPC connection was dropped.

DTF0394E

UNEXPECTED NOTIFICATION OF INTERCONNECTION FAILURE TO  
*manager-name* BECAUSE INTERCONNECTION NOT PREVIOUSLY  
RECORDED

**Recipients:** 0

**Explanation:** The indicated Node Manager notified the Network Manger of a failed interconnect request but the request was not active to the Network Manager.

**User Action:** None required.

DTF0395E

MGMT INTERCONNECTION SERVICING *manager-name* REQUEST FOR  
TRANSFER SESSION ON LU *vtam-lu-name* ACCESS *dtf-access-number*  
FAILED WITHOUT RESPONSE

**Recipients:** 0

**Explanation:** The management connection to the indicated Node Manager has been severed. Any transfer sessions pending are rejected.

**User Action:** Restart the Node Manager. Retry the transfer.

DTF0420E

SUBTASK ID *subtask-name* COULD NOT BE DETACHED

**Recipients:** 0

**Explanation:** The indicated subtask cannot be detached during shutdown. DTF continues shutting down. A system abend may occur when DTF exits with the subtask still attached.

**User Action:** Chapter 3 explains how to collect information and report problems.

DTF0421C

THE RESOURCE TASK *task-name* HAS FAILED

**Recipients:** 0

**Explanation:** The indicated RESOURCE task has failed and shut down. DTF ends without notifying users or detaching subtasks.

**User Action:** This is usually the result of a DTF for IBM software error. Chapter 3 explains how to collect information and report problems.

DTF0422C

PERMANENT TASK *task-name* HAS FAILED

**Recipients:** 0

**Explanation:** The indicated installation-dependent permanent task failed. DTF ends without notifying users or detaching subtasks.

**User Action:** Informational. No action is necessary.

DTF0500I

TRAN -NET(*net-name*) ACC(*dtf-access-number*) USER(*user-id*) WITH(*manager-name@node-name*)

**Recipients:** 9

**Explanation:** This message is displayed in response to a console command. It describes the logical unit used for a file transfer. The indicated manager name refers to the File Manager.

**User Action:** Informational. No action is necessary.

DTF0501I

SERV -NET(*net-name*) ACC(*dtf-access-number*) NODE(*node-name*) USERS(*number-of-users*)

**Recipients:** 9

**Explanation:** This message is displayed in response to a console command. It describes the logical unit being used for a server session. The *number-of-users* is the number of IBM-initiated user requests being handled by this server session.

**User Action:** Informational. No action is necessary.

DTF0502I

(*vtam-lu-name* or *dtf-access-number*) NOT FOUND

**Recipients:** 9

**Explanation:** This message is displayed in response to an INQUIRE console command. It results if the INQUIRE command specifies a resource that is not being used by DTF.

**User Action:** Informational. No action is necessary.

DTF0503I

*command* REQUEST FROM CONSOLE *console-id* ON *date* AT *time*

**Recipients:** 1

**Explanation:** This message is displayed in response to a console command and acknowledges a console request.

**User Action:** Informational. No action is necessary.

DTF0504I

DTF CONSOLE REQUEST COMPLETE

**Recipients:** 9

**Explanation:** This message is displayed when all processing for a console command is complete.

**User Action:** Informational. No action is necessary.

DTF0505I

INTER-PATH(*path-name*) ACC(*dtf-access-number*) WITH(*component-name@node-name*)

**Recipients:** 9

**Explanation:** This message displays in response to a console command. It describes the DTF interconnection.

**User Action:** Informational. No action is necessary.

DTF0506I

USER -USER(*user-id@node-name*) ACC(*dtf-access-number*) SERVER(*server-name*) TRANS(*dtf-access-number*)

**Recipients:** 9

**Explanation:** This message displays in response to a console command. It describes the DTF interconnection.

**User Action:** Informational. No action is necessary.

DTF0511I

ENTER ONE OF THE FOLLOWING: *text*

**Recipients:** 9

**Explanation:** This message is displayed in response to an incomplete console command. The *text* variable is replaced with the possible values for the missing portion of the command. Chapter 4 describes the console commands.

**User Action:** Decide which options should be used to complete the command and reenter the entire command.

DTF0512I

INVALID COMMAND: *command*

**Recipients:** 9

**Explanation:** The indicated console command was not recognized.

**User Action:** Correct the indicated command and reenter the entire string.

DTF0513I

INVALID COMMAND ABBREVIATION *abbreviation* IS ASSUMED TO BE *command*

**Recipients:** 9

**Explanation:** The indicated console command contains an ambiguous command abbreviation. DTF assumes you mean the indicated command.

**User Action:** No action is necessary. The command is accepted.

DTF0514I

NOT FOUND, NO INFORMATION AVAILABLE

**Recipients:** 9

**Explanation:** This message is displayed in response to an INQUIRE console command when the appropriate sessions cannot be found. This is a normal response if DTF sessions are not active.

**User Action:** No action is necessary. This is a normal response.

DTF0515I  
OPTION *option* IS NOT VALID AND IS IGNORED

**Recipients:** 9

**Explanation:** The indicated console command contains an unrecognized keyword or keyword value. The command is processed and the invalid portion is ignored.

**User Action:** No action is necessary. The command is accepted.

DTF0516I  
DTF *characteristic* IS NOW SET TO *state*

**Recipients:** 9

**Explanation:** This message is displayed in response to a console command setting a characteristic.

**User Action:** Informational. No action is necessary.

DTF0590E  
LOGGING DISABLED DUE TO ERROR IN LOGGING EXIT

**Recipients:** 1

**Explanation:** Logging was terminated in the DTF component.

**User Action:** There may be a system dump or a message to the console to indicate why logging was disabled.

**Note:** The DTF0590E message is issued under one of the following circumstances:

- The logging exit returns an indicator that tells the DTF component to stop calling the logging exit.
- The DTF component intercepts a system error while the exit was in control. The DTF component disabled the exit.

DTF0600I  
LU *vtam-lu-name* ACTING AS SERVER SESSION FOR NODE *node-name* AT  
*time*

**Recipients:** 1

**Explanation:** A server node started a server session with DTF.

**User Action:** Informational. No action is necessary.

DTF0601E

ERROR REPORTED WHILE TRYING TO BIND LU *vtam-lu-name* AS  
SERVER SESSION, VTAM RETURN CODE / FEEDBACK CODE *feedback-*  
*code* AT *time*

**Recipients:** 0

**Explanation:** VTAM could not bind the indicated LU for use as a server session because of an error.

**User Action:** Check the combined return code and feedback code to see why. The DECnet server node trying to use this LU does not have an available server session.

**Note:** The first 4 digits of *feedback-code* are the return code from the OPNDST macro instruction. The second 4 digits are the feedback code from the same macro. Both numbers are reported in decimal format.

If this error occurs frequently, then a second line that explains these codes is displayed. If a second line is not displayed, check the IBM *VTAM Programming* manual for the meaning of the return code and the feedback code.

DTF0602E

DTF REJECTED THE SERVER SESSION WITH LU *vtam-lu-name* FOR  
REASON CODE *reason-code*

**Recipients:** 0

**Explanation:** DTF rejected the indicated server session because of invalid session parameters. Each reason code is explained in more detail in the following entries.

**User Action:** The user action depends on the reason code; see the User Action column in the table that follows.

---

<i>reason-</i> <i>code</i>	Explanation	User Action
00000016	DTF cannot begin a new access because a shutdown is in progress.	Retry the access later.

---

<i>reason-code</i>	<b>Explanation</b>	<b>User Action</b>
00000020	An invalid session establishment request was received from a DECnet node. The session was rejected and the LU is unbound.	Check the configuration files of the DECnet node initiating the session request. If you cannot find any problems, refer to Chapter 3, which explains how to collect information and report problems.
00000040	A DECnet LU returned a negotiated bind response that is not within allowable session parameters. The LU is unbound. The request unit size is the only bind parameter that is negotiated. This error is probably caused by a problem with the DECnet accessor.	Chapter 3 explains how to collect information and report problems.
00000044	The outbound RU size is too small. The LOGMODE entry for the server session specifies an outbound RU size that is too small.	The <i>Digital SNA Data Transfer Facility Installation (VM)</i> or <i>Digital SNA Data Transfer Facility Installation (MVS)</i> manual provides the RU settings.
00000048	The outbound RU size cannot be set to zero.	Check the LOGMODE entry for this LU to ensure that the RUSIZES value is not set to zero. The outbound RU size is contained in the second 2 digits of the RUSIZES field. The IBM manual <i>IBM VTAM Customization</i> explains the format of the RUSIZES parameter.
00000052	The inbound RU size cannot be set to zero.	Check the LOGMODE entry for this LU and make sure that the RUSIZES value is not set to zero. The inbound RU size is contained in the first 2 digits of the RUSIZES field. The IBM manual <i>IBM VTAM Customization</i> explains the format of the RUSIZES parameter.



<i>reason-code</i>	<b>Explanation</b>	<b>User Action</b>
00000072	The setting for MAXSERVERS has been exceeded. The server session is unbound. The indicated server node is unavailable to IBM DTF users until this situation is corrected.	Stop one of the other server sessions in order to allow the indicated session to proceed.

DTF0603E

VTAM HAS REJECTED AN UNBIND REQUEST FOR LU *vtam-lu-name* WITH R15/R0 EQUAL TO *register-values* AT *time*

**Recipients:** 0

**Explanation:** VTAM refused to unbind the indicated server session.

**User Action:** Check the value of register 15 and register 0 to see why VTAM refused to unbind the server session. The LU should be varied inactive by a VTAM command to cancel the session.

**Note:** The first 4 digits of *register-values* are the value in register 15 after the CLSDST macro instruction. The second 4 digits are the value in register 0 after the CLSDST macro instruction. Both numbers are reported in hexadecimal format.

If this error occurs frequently, then a second line that explains these codes is displayed. If a second line is not displayed, check the VTAM documentation for the meaning of register 15 and register 0.

DTF0611S

DTF UNABLE TO PROCESS REQUEST BECAUSE OF MEMORY CONSTRAINT

**Recipients:** 4

**Explanation:** DTF could not handle a user request from the subsystem interface because no memory was available.

**User Action:** The request can be resubmitted. If the request is rejected multiple times, then DTF should be restarted with a larger region size.

DTF0612I

A SERVER SESSION IS NOT AVAILABLE FOR THIS REQUEST

**Recipients:** 4

**Explanation:** DTF could not find a server node to process the user's request.

**User Action:** If the server node is not important to you, clear the server keyword value so that DTF can select a server node. If you need a specific server, you must verify that the node has the server software installed and activated.

You can examine the list of servers from the DTF component console.

DTF0613W

UNABLE TO CONTACT USER *user-id* FOR COMPLETION OF REQUEST

**Recipients:** 1

**Explanation:** DTF is unable to report the outcome of the request back to a requester.

**User Action:** No action is necessary. This is a normal message if connection to the user is lost.

DTF0614I

REQUEST FROM USER *user-id* ROUTED TO SERVER NODE *node-name*

**Recipients:** 1

**Explanation:** A request was accepted through the subsystem interface and routed to the indicated DECnet server node.

**User Action:** No action is necessary. This is a normal message.

DTF0615E

DTF NETWORK MANAGER IS IN SHUTDOWN MODE

**Recipients:** 1

**Explanation:** A request has been rejected because the DTF Network Manager is now in shutdown mode.

**User Action:** Retry the request later.

DTF0616E

DTF NETWORK MANAGER IS AT CONFIGURATION MAXIMUM FOR THIS REQUEST TYPE

**Recipients:** 1

**Explanation:** A request has been rejected because the DTF Node Manager has reached one of these maximum configuration settings:

- MAXIBMUSERS - The setting for maximum IBM users has been reached.
- MAXTRANSFERS -The setting for maximum transfers has been reached.

**User Action:** Retry the request later.

DTF0630E

RECOVERABLE ERROR REPORTED FROM SERVER *server-name*

**Recipients:** 12

**Explanation:** A recoverable transfer failed but the indicated server node reports that the transfer can be retried.

**User Action:** Retry the transfer (only the request number is required). See the OpenVMS error messages for the failure message.

DTF0631E

NON-RECOVERABLE ERROR REPORTED FROM SERVER *server-name*

**Recipients:** 12

**Explanation:** A recoverable transfer failed and the indicated server node reports that the transfer cannot be retried.

**User Action:** The transfer cannot be retried. See the OpenVMS error messages for the text of the hard error.

DTF0632S

REQUEST *request-number* ON LU *vtam-lu-name* FAILED DUE TO MEMORY CONSTRAINTS

**Recipients:** 5

**Explanation:** DTF is unable to pass a request to the indicated server node because no output buffer is available. The DECnet command dispatcher is left in an unknown state. Resources may be allocated to this request, which will not be released until DTF releases the indicated server session LU.

**User Action:** Restart DTF with a larger region.

DTF0633E

SERVER SESSION FOR NODE *server-name* FAILED BEFORE REQUEST SUBMITTED

**Recipients:** 12

**Explanation:** The server session used to start the user request failed.

**User Action:** The transfer request had not been submitted at the time of the failure. This is probably a transient error situation. Resubmit the request after reestablishing the server session.

DTF0634E

INCOMPLETE PARAMETER LIST, REQUEST NOT SUBMITTED

**Recipients:** 12

**Explanation:** An incomplete parameter list was submitted to DTF. The request was refused.

**User Action:** Complete the missing parameters and resubmit the request.

DTF0635E

ERROR ON CONNECT TO SERVER *server-name*

**Recipients:** 12

**Explanation:** The indicated server node rejected a user request. This error occurs before a transfer begins. This is probably a problem with OpenVMS/DTF.

**User Action:** Examine the error message reported from the server node to determine why the request was rejected. Chapter 3 explains how to collect information and report problems.

DTF0636S

SERVER SESSION INTERFACE CLOSED BECAUSE OF VTAM ERROR

**Recipients:** 1

**Explanation:** A VTAM error caused the server session interface to become inactive. This is probably caused by a DTF for IBM software error.

**User Action:** Shut down DTF to notify all users of an error. Chapter 3 explains how to collect information and report problems.

DTF0637I

POSSIBLE RACE CONDITION ON SERVER NODE *server-name* IS  
IGNORED

**Recipients:** 0

**Explanation:** A server session returned information about a user request that is no longer active. A canceled request could cause this condition.

**User Action:** Informational. No action is necessary.

DTF0638S

SERVER SESSION SEQUENCE ERROR WITH NODE *server-name* FOR  
USER *user-id*

**Recipients:** 4

**Explanation:** The indicated server node returned a server session message out of sequence. The status of the transfer cannot be determined. This is either a DTF for IBM software error or an OpenVMS/DTF software error.

**User Action:** Chapter 3 explains how to collect information and report problems.

DTF0639E

ERRORS DETECTED ON SERVER SESSION FOR SERVER NODE *server-*  
*name*

**Recipients:** 1

**Explanation:** DTF is having problems with data sent by the server session for the indicated server node. One or more user requests may be involved. This is either a DTF for IBM software error or an OpenVMS/DTF software error.

**User Action:** Chapter 3 explains how to collect information and report problems.

DTF0640E

VTAM HAS REJECTED AN UNBIND REQUEST FOR LU *vtam-lu-name*  
WITH R15/R0 EQUAL TO *register-values*

**Recipients:** 0

**Explanation:** VTAM refused to unbind the indicated server session LU.

**User Action:** Check the value of register 15 and register 0 to see why VTAM refused to unbind the server session LU. The LU should be varied inactive by a VTAM command to cancel the session.

**Note:** The first 4 digits of *register-values* are the value in register 15 after the CLSDST macro instruction. The second 4 digits are the value in

register 0 after the CLSDST macro instruction. Both numbers are reported in hexadecimal format.

If this error occurs frequently, then a second line that explains these codes is displayed. If a second line is not displayed, check the VTAM documentation for the meaning of register 15 and register 0.

DTF0641I

SERVER SESSION FOR NODE *server-name* REPORTED COMPLETE

**Recipients:** 1

**Explanation:** The server session with the indicated server node was disconnected.

**User Action:** No action is necessary. This is a normal message when the OpenVMS/DTF server software is stopped.

DTF0642E

TRANSFER SUCCESSFUL - ERROR IN POST PROCESSING

**Recipients:** 12

**Explanation:** The file was transferred; however, there was an error in submitting the post-processing file to the batch system. Review the descriptive messages which follow this error for the reason that the post processing failed.

**User Action:** Since the transfer succeeded, it is not necessary to re-transfer the entire file. You can transfer an empty file with a corrected post-processing file in order to restart at the post-processing phase.

DTF0711I

DTF IN CONTROLLED SHUTDOWN

**Recipients:** 1

**Explanation:** DTF detected an error condition and is trying to shut down in a controlled manner.

**User Action:** Check the system log for the reason for the shutdown.

DTF0820S

FIRST SPEAKER FAILED TO SEND HANDSHAKE, PATH SEVERED

**Recipients:** 1

**Explanation:** A DTF IUCV/APPC protocol violation occurred. The connection is immediately severed.

**User Action:** There is a possible error in the APPC/IUCV connection. Chapter 3 explains how to collect information and report problems.

DTF0851I

DTF COMPLETED *path-name* CONNECTION TO *component-name* AT *node-name*, ACCESS *dtf-access-number* AT *time*

**Recipients:** 1

**Explanation:** This message is issued when a connection has been completed.

**User Action:** Informational. No action is necessary.

DTF0852E

INTERCONNECTION TO *component-name*, RESOURCE *resource-name*,  
COULD NOT BE ESTABLISHED BECAUSE OF MEMORY SHORTAGE

**Recipients:** 0

**Explanation:** A transfer session was rejected due to a memory shortage.

**User Action:** Increase the virtual machine storage size. Restart DTF.

DTF0853I

INTERCONNECTION FOR TRANSFER SESSION ON *vtam-lu-name*  
ACCESS *dtf-access-number* HAS BEEN RELEASED DUE TO APPARENT  
PREVIOUS FAILURE

**Recipients:** 0

**Explanation:** See previous messages for causes.

**User Action:** Informational. No action is necessary.

DTF0859I

TRANSFER SESSION ON *vtam-lu-name* HAS ACQUIRED AN *connection-type*  
CONNECTION TO *component-name* AT *node-name*, ACCESS *dtf-access-*  
*number* AT *time*

**Recipients:** 1

**Explanation:** This message is issued when the APPC/IUCV connection has been completed.

**User Action:** Informational. No action is necessary.

DTF0901I

LU *vtam-lu-name* ACCESS *dtf-access-number* LINK TERMINATION CODE IS  
*reason-code*

**Recipients:** 0

**Explanation:** This message records the reason for session termination.

**User Action:** The user action depends on the reason code; see the User Action column in the table that follows.

<i>reason-code</i>	<b>Explanation</b>	<b>User Action</b>
00000008	The VTAM LOSTERMINAL signaled that the session is no longer active. This is not a normal session termination message. It may signal problems with VTAM buffering for this logical unit.	Chapter 3 explains how to collect information and report problems.
00000016	This is a normal session termination message.	No action is necessary.
00000020	This is not a normal communications link termination. It could signal a VTAM problem.	Chapter 3 explains how to collect information and report problems.
00000024	This is not a normal communications link termination. It could signal a VTAM problem.	Chapter 3 explains how to collect information and report problems.
00000028	This is not a normal communications link termination. It could signal a VTAM problem.	Chapter 3 explains how to collect information and report problems.

DTF0902I

LU *vtam-lu-name* ACCESS *dtf-access-number* IS REQUESTING THE ACCESS TERMINATION WITH REQUEST CODE: *request-code*

**Recipients:** 0

**Explanation:** This message records DTF making a request to the DECnet accessor to have the access terminated.

**User Action:** The user action depends on the reason code; see the User Action column in the table that follows.

<i>request-code</i>	<b>Explanation</b>	<b>User Action</b>
00000004	The VTAM RECEIVE RPL exit missed an incoming DAP message because of a buffer shortage.	Increase the region size and retry the access.
00000012	The VTAM SCIP exit has received an unexpected value.	Chapter 3 explains how to collect information and report problems.
00000032	The IBM operator requested that this session be terminated.	No action is necessary. The transfer can be retried.

DTF2001E



MDPW EXIT DETECTED MINIDISK PASSWORD VIOLATION BY *user-id*  
LINKING TO *minidisk-owner minidisk-address*

**Recipients:** 1

**Explanation:** A minidisk password violation was detected during the minidisk password validate/supply function. The DTF component rejects the transfer with a privilege violation. The DTF component has trapped the error before attempting the minidisk link.

**User Action:** Correct the minidisk password and retry the file access.

DTF2002E  
LOGON PASSWORD VIOLATION FOR USER *user-id* DETECTED BY MDPW  
EXIT

**Recipients:** 1

**Explanation:** The VMSECURE exit performed a password check on the user ID and the check failed. The user is returned a privilege violation.

**User Action:** Correct the logon password information and retry the request.

DTF2003E  
ERROR LINKING CAUSED BY USER *user-id* LINKING TO *minidisk-owner*  
*minidisk-address*

**Recipients:** 1

**Explanation:** A CMS minidisk link request was performed and it failed due to a minidisk password violation. The user is returned a privilege violation.

**User Action:** Correct the minidisk password and retry the request.

DTF2004E  
SECURITY EXIT REJECTED LINK REQUEST BY USER *user-id* LINKING  
TO *minidisk-owner minidisk-address*

**Recipients:** 1

**Explanation:** The security exit rejected the request to link to the indicated minidisk. The user is returned a privilege violation.

**User Action:** Contact your security administrator.

DTF2005E

MINIDISK LINK ERRORS HAVE BEEN EXCEEDED. REQUEST BY USER *user-id* FOR *minidisk-owner minidisk-address* HAS BEEN REJECTED

**Recipients:** 1

**Explanation:** The DTF component has failed to link to the indicated minidisk because the CP maximum for link password violations by this component has been exceeded. The user is returned a privilege violation.

**User Action:** The VM system programmer should identify the cause of the link password error count having been exceeded. The minidisk password validate/supply feature can help to avoid this condition. The DTF virtual machine must be stopped and restarted to clear this condition.

DTF2006E

SECURITY EXIT REJECTED SIGNON BY USER *user-id*

**Recipients:** 1

**Explanation:** The security exit has indicated that the user is to be denied a logon. The user is returned a privilege violation.

**User Action:** Correct the logon password and retry the request.

DTF2007E

SECURITY SYSTEM NOT ACTIVE, REQUEST BY USER *user-id* REJECTED

**Recipients:** 1

**Explanation:** The security exit was called to validate the access and it indicated that the security system is not active. The user is returned a privilege violation.

**User Action:** Contact the VM system programmer.

DTF2008E

VMSECURE NOT AUTHORIZED FOR MACHINE

**Recipients:** 1

**Explanation:** The VMSECURE security exit attempted to do a validation of the user ID and password; however, the exit was notified that the DTF component does not have the necessary authority to do the validation. The user is returned a privilege violation.

**User Action:** This is an installation error. You should refer to the *Digital SNA Data Transfer Facility Installation (VM)* manual to see how to authorize the DTF component.

DTF2009E

RETURN CODE FROM MDPW EXIT NOT UNDERSTOOD, LINK REQUEST  
FROM USER *user-id* TO *minidisk-owner minidisk-address* DENIED

**Recipients:** 1

**Explanation:** A call to the minidisk password exit returned an unexpected error condition. The user is returned a privilege violation.

**User Action:** The VM system programmer should determine what caused the condition within the exit and attempt to correct the situation.

DTF2010E

ALTERNATE USER DIAG D4 FAILED WITH RETURN CODE *return-code*

**Recipients:** 1

**Explanation:** DTF has attempted to issue the x'D4' Diagnose instruction to perform a function on behalf of the specified user ID and has failed.

**User Action:** Consult the *Digital SNA Data Transfer Facility for Installation (VM)* for the proper security procedures to give the DTF Node Manager virtual machine the authority to perform this function.

DTF2301S

SERVER NODE *server-name* HAS GONE OUT OF SERVICE WHILE  
PROCESSING YOUR REQUEST

**Recipients:** 12

**Explanation:** The server session that was servicing the user's request failed. The status of the transfer cannot be determined. This is an OpenVMS/DTF error.

**User Action:** Chapter 3 explains how to collect information and report problems.

DTF2302S

UNABLE TO CONTACT USER *user-id* TO NOTIFY OF SERVER SESSION  
FAILURE

**Recipients:** 1

**Explanation:** DTF is unable to report back to the indicated user that a server session failed before a request completed. This is probably due to a user session failure during a DTF request.

**User Action:** Informational. No action is necessary.

DTF2401S

A STATUS MESSAGE FOR LU *vtam-lu-name* ACCESS NUMBER *dtf-access-number* OF *number* (OCTAL) COULD NOT BE SENT BECAUSE OF MEMORY PROBLEMS

**Recipients:** 0

**Explanation:** This is a memory problem. Access is terminated and the DECnet accessor is notified.

**User Action:** Increase the DTF component region size.

**Note:** Message DTF2403I explains the replacement characters.

DTF2403I

STATUS MESSAGE SENT TO LU *vtam-lu-name* ACCESS NUMBER *dtf-access-number*; STATUS CODE IS *dap-code* (OCTAL FORMAT IS *status-code*)

**Recipients:** 0

**Explanation:** This message records all DAP status messages sent to the DECnet node.

Depending on the meaning of the status code, this can either signal a problem or be regarded as normal. If a problem occurs, the DECnet LU determines whether or not the access is continued.

**User Action:** The user action depends on the reason code; see the User Action column in the table that follows.

**Note:** To make problem determination easier, the DAP status code is also displayed in octal format. All DAP status codes are documented in this format. The first 2 characters are known as the MACCODE; the last 6 characters are known as the MICCODE.

<i>status-code</i>	Explanation	User Action
04000100	The error recovery routine was entered for the transfer and the transfer was labeled as a failure. This error occurs before a file is opened. This status code will result in an abend dump by the DTF Network Manager.	Chapter 3 explains how to collect information and report problems.

<b><i>status- code</i></b>	<b>Explanation</b>	<b>User Action</b>
04002200	DTF for IBM found a logic error and notified the accessing node of the condition. This error occurs before a file is opened.	Check for a message that describes the internal error. Chapter 3 explains how to collect information and report problems.
04003000	A file create request failed.	Check for a message that describes the file create failure.
04005500	A file create request failed because a file with that name already exists.	Delete the old file and retry the request. You can also use the supersede option to delete the file.
04006000	A file create/open request was rejected because another user is accessing the file.	Wait for the file to be freed, then retry the request.
04006200	A file open request was rejected because the file was not found.	Check the spelling of the data set name.
04012500	The requested access was denied because the security system rejected the request.	Correct the user ID, the password, or both and retry the request.
05000100	The error recovery routine entered for this transfer was marked as a failure. The file remains open until the remote system closes it. This status code is accompanied by a DTF component abend dump.	Chapter 3 explains how to collect information and report problems.
05002200	DTF for IBM found a logic error and notified the accessing node of the condition. The open file remains open until the remote system closes it.	Check for a message that describes the internal error.
05004700	The end of file was reached while reading a file.	No action is necessary. This is a normal message.
07000100	The error recovery routine entered for this transfer was marked as a failure. The file that was opened is now closed. This status code is accompanied by a DTF component abend dump.	Chapter 3 explains how to collect information and report problems.

<i>status-code</i>	<b>Explanation</b>	<b>User Action</b>
07002200	DTF for IBM found a logic error and the accessing node is notified of the condition. The file that was opened is now closed.	Check for a message that describes the internal error. Chapter 3 explains how to collect information and report problems.

DTF3001C  
CSA MEMORY NOT RELEASED

**Recipients:** 1

**Explanation:** During shutdown of DTF, a buffer in the CSA was not released. The buffer will remain unused until the next system initial program load (IPL) is done.

**User Action:** Chapter 3 explains how to collect information and report problems.

**Note:** The MAXIBMUSERS initialization parameter controls the actual size of the buffer. If this is a relatively small value and your site is not CSA constrained, this condition may not be considered serious. Otherwise, if CSA availability is a major problem, you should schedule an IPL at the earliest possible time.

DTF3002C  
SYSTEM CROSS MEMORY AUTHORIZATION NOT RELEASED

**Recipients:** 1

**Explanation:** During shutdown of DTF, a unique cross memory authorization code was not released. The code remains reserved by MVS until the next system IPL is done.

**User Action:** Chapter 3 explains how to collect information and report problems.

**Note:** Cross memory authorization codes are a limited resource. DTF has not returned its index to the table of available indexes. This error, although not immediately a problem, may cause unknown problems if allowed to continue. An IPL should be done.

DTF3003I  
SUBSYSTEM INTERFACE IS CLOSED

**Recipients:** 1

**Explanation:** The subsystem interface was closed during the shutdown of DTF.

**User Action:** No action is necessary. This is a normal shutdown message.

DTF3004I  
CSA MEMORY RELEASED

**Recipients:** 1

**Explanation:** All CSA memory was released during the shutdown of DTF.

**User Action:** No action is necessary. This is a normal shutdown message.

DTF3005I  
SYSTEM CROSS MEMORY AUTHORIZATION FREED

**Recipients:** 1

**Explanation:** The unique cross memory authorization code was released during the shutdown of DTF.

**User Action:** No action is necessary. This is a normal shutdown message.

DTF3006I  
DTF SHUTDOWN DATE: *date* AND TIME: *time*

**Recipients:** 0

**Explanation:** Notifies users of the date and time when the DTF component shut down.

**User Action:** Informational. No action is necessary.

DTF3101I  
LU *vtam-lu-name* ACCESS NUMBER *dtf-access-number* MARKED AS  
FAILURE; FAILURE CODE IS *failure-code*

**Recipients:** 0

**Explanation:** An internal error was recorded for the indicated access number. When possible, a status code is sent to the DECnet accessor and the session remains active until the accessor terminates the access.

**User Action:** The user action depends on the reason code; see the User Action column in the table that follows.

---

<i>failure-code</i>	Explanation	User Action
00000004	This error probably happened because the SNA session failed at an unexpected point. This message may appear out of sequence because of a timing problem.	Check all messages for any errors that might have caused the remote system to terminate the session unexpectedly.

<i>failure-code</i>	<b>Explanation</b>	<b>User Action</b>
00000008	This error probably happened because the SNA session failed at an unexpected point. This message may appear out of sequence because of a timing problem.	Check all messages for any errors that might have caused the remote system to terminate the session unexpectedly.
00000012	A communications error caused the remote system to send a response to DTF for IBM. This message may appear out of sequence because of a timing problem.	Chapter 3 explains how to collect information and report problems.
00000016	A communications error caused the remote system to send an SNA RU that DTF for IBM cannot handle. This message may appear out of sequence because of a timing problem.	Chapter 3 explains how to collect information and report problems.
00000020	A communications error prevented VTAM from sending an RU to the remote system. The SNA session probably terminated after the send was accepted by VTAM. This message may appear out of sequence because of a timing problem.	Check all messages for any errors that might have caused the remote system to terminate the session unexpectedly.
00000024	A communications error caused the remote system to send an SNA exception response. This message may appear out of sequence because of a timing problem.	Chapter 3 explains how to collect information and report problems.



DTF4000E

IUCV SET REQUEST FOR NAME "*program-name*" FAILED WITH RC =  
*reason-code*

**Recipients:** 1

**Explanation:** IUCV refused a SET request. A reason code of 04 indicates that the name has already been assigned.

**User Action:** Check the return code to see the reason for the error. The IBM manuals *System Facilities for Programming and CP Programming Services* describe the IUCV codes. Correct the problem and restart DTF.

DTF4001I

IUCV SET REQUEST FOR NAME "*program-name*" SUCCESSFUL

**Recipients:** 1

**Explanation:** IUCV/APPC has successfully established itself as ready for communication interrupts.

**User Action:** Informational. No action is necessary.

DTF4012E

VTAM HAS REJECTED A SEND REQUEST FOR LU *vtam-lu-name* ACCESS  
NUMBER *dtf-access-number* WITH R15/R0 EQUAL TO *register-values*

**Recipients:** 0

**Explanation:** VTAM failed to send a message. Access is terminated and the DECnet accessor is not notified. This is a session failure.

**User Action:** Check the value of register 15 and register 0 to see why. No action should be necessary.

**Note:** The first 4 digits of *register-values* are the value in register 15 after the SEND macro instruction. The second 4 digits are the value in register 0 after the SEND macro instruction. Both numbers are reported in hexadecimal format.

If this error occurs frequently, then a second line is displayed explaining these codes. If the second line does not appear, check the VTAM documentation for the meaning of register 15 and register 0.

Reason Code in Log	Explanation	User Action
000C000B	The SNA session went down after VTAM accepted a send request. The request is marked as failed and DTF for IBM notes that condition. This error is caused by the remote system shutting the link down earlier than expected. This message may appear out of sequence because of a timing problem.	Try to locate a message that indicates why the link was terminated early.

DTF4020I

DTF/*connection-type* INTERCONNECTION TO *component-name*, ACCESS *dtf-access-number*, PATH *path-name*, SEVERED AT *time*

**Recipients:** 1

**Explanation:** A communication path to the indicated VM ID has been severed.

**User Action:** Informational. No action is necessary.

DTF4030E

DTF/IUCV SEND ERROR, ACCESS *dtf-access-number*, IPRCODE = *iprcode* AT *time*

**Recipients:** 1

**Explanation:** An IUCV or APPC send message failed.

**User Action:** Research the indicated IUCV/APPC IPRCODE using the IBM *System Facilities for Programming* manual or *CP Programming Services* manual. Correct the error and retry the transfer.

DTF4040E

*connection-type* CONNECT TO "*component-name*" FAILED, IPRCODE = *iprcode* AT *time*

**Recipients:** 1

**Explanation:** An IUCV or APPC connect request failed.

**User Action:** Research the indicated IUCV/APPC IPRCODE using the IBM *System Facilities for Programming* manual or *CP Programming Services* manual. Correct the error and retry the transfer.

DTF4041E

RESOURCE NAME "*resource-name*" NOT ACTIVE AT *time*

**Recipients:** 1

**Explanation:** An IUCV or APPC connect request failed because the other VM ID has not identified the indicated resource name as a valid IUCV or APPC program or because the requested program is not active.

**User Action:** Restart the indicated DTF component (the DTF Network Manager).

DTF4042I

*connection-type* PATH TO *component-name* READY, PATHID = *path-name* AT *time*

**Recipients:** 1

**Explanation:** An IUCV or APPC connect request has completed. This message is displayed only if DTF is running in DEBUG mode.

**User Action:** Informational. No action is necessary.

DTF4043I

*connection-type* CONNECT REQUEST TO *component-name* ENDED BY SEVER AT *time*

**Recipients:** 1

**Explanation:** An IUCV/APPC connect request was rejected.

**User Action:** Check the log of the VM ID that DTF was trying to connect with for a reason code.

DTF4044I

*connection-type* CONNECT REQUEST TO *component-name* ENDED BY HANDSHAKE ERROR AT *time*

**Recipients:** 1

**Explanation:** An IUCV/APPC connect request was rejected.

**User Action:** Check for the possibility of other software trying to access DTF.

DTF4170I

TRANSFER SESSION ON LU *vtam-lu-name* ACCESS *dtf-access-number* BELONGS TO USER *user-id*

**Recipients:** 1

**Explanation:** A transfer request has been identified as belonging to the indicated user.

**User Action:** Informational. No action is necessary.

DTF5100S

CMDUNKN - INVALID COMMAND "*command*" SENT TO *component-name*  
AT *node-name* FROM *user-id* AT *node-name time*

**Recipients:** 1

**Explanation:** An IUCV or APPC connect request has been rejected.

**User Action:** Use the DEBUG option to research the error in the originating system's log.

DTF5101S

REJECT - *component-name node-name* REJECTED START FROM *component-name node-name* TO *vtam-lu-name* ACCESS *dtf-access-number*, MEMORY SHORTAGE- *time*

**Recipients:** 1

**Explanation:** A DTF transfer session is being rejected.

**User Action:** Increase the virtual storage machine size for the VM ID that rejected the transfer request. Restart the DTF system. Retry the request.

DTF5102S

REJECT - *component-name node-name* REJECTED START FROM *component-name node-name* TO *vtam-lu-name* ACCESS *dtf-access-number*, RESOURCE SHORTAGE *time*

**Recipients:** 1

**Explanation:** A DTF transfer session is being rejected.

**User Action:** Increase the virtual storage machine size for the VM ID that rejected the transfer request. Restart the DTF system. Retry the request.

DTF5103I

AUTOMATIC RETRY SCHEDULED IN *n* SECONDS TO CONNECT TO  
*vm-node-name* (MANAGEMENT)

**Recipients:** 1

**Explanation:** This message is displayed when the Node Manager fails to connect to a Network Manager. DTF for IBM will retry the operation in *n* seconds.

The message is also displayed if the Network Manager connection is lost. The DTF Node Manager will automatically try to reestablish the connection and issues this warning message periodically until the connection is made.

**User Action:** Start the DTF Network Manager system.

DTF5400I

*receive-data*

**Recipients:** 0

**Explanation:** This is displayed only when the system is in DEBUG mode. The first 120 bytes of IUCV/APPC data being received are displayed.

**User Action:** Informational. No action is necessary.

DTF5500I

APPC/VM RESOURCE MANAGER INITIALIZED FOR "*resource-name*",  
SCOPE IS "*scope*"

**Recipients:** 1

**Explanation:** DTF has successfully identified itself to TSAF as a resource manager. The *scope* variable is replaced with either GLOBAL or LOCAL.

**User Action:** Informational. No action is necessary.

DTF5501E

APPC/VM RESOURCE MANAGER INITIALIZE FAILED FOR "*resource-name*", SCOPE = "*scope*"

**Recipients:** 1

**Explanation:** DTF has unsuccessfully identified itself to TSAF as a resource manager for the indicated resource name. The *scope* variable is replaced with either GLOBAL or LOCAL.

**User Action:** Verify that this ID is allowed to connect to \*IDENT and that your TSAF group is active. Correct the problem. Restart DTF.

DTF6021E

LU *vtam-lu-name* ACCESS *access-name* FILE NAME *file-name*, OPEN  
FAILURE CODE = *failure-code*

**Recipients:** 0

**Explanation:** A file open failed.

**User Action:** The user action depends on the reason code; see the User Action column in the table that follows.

<i>failure-code</i>	<b>Explanation</b>	<b>User Action</b>
00000001	The file was not opened because DTF for IBM did not get enough memory for an internal control block.	Increase the region size and retry the request.
00000002	The file was not opened because the OPEN macro failed. This is an unexpected error.	Chapter 3 explains how to collect information and report problems.
00000003	The file was not opened/created because DTF for IBM is purging all activity for this session.	Try the request later.
00000004	The file was not opened/created because DTF for IBM is shutting down. All requests are terminated early.	Try the request later.
00000005	The CLOSE macro did not close the file. This is an unexpected error.	Chapter 3 explains how to collect information and report problems.
00000006	The open/close request was not recognized by the internal DTF for IBM resource manager because of a logic error. This is an unexpected error.	Chapter 3 explains how to collect information and report problems.
00000007	A logic error corrupted the table of available files. This is an unexpected error.	Chapter 3 explains how to collect information and report problems.
00000008	The DTF for IBM resource manager rejected an invalid record format.	DTF cannot copy a file with this record format. Correct the record format and retry the request.
00000009	The DTF for IBM resource manager rejected an invalid data set organization (DSORG).	DTF cannot copy a file with this data set organization. Correct the DSORG and retry the request.
00000010	DTF for IBM internal usage flags prevent multiple requesters from sharing a file. This is a normal error if two users try to control a file exclusively.	Wait for the file to be freed and retry the request.
00000011	A read request was rejected because a user with exclusive control allocated the file. This is a normal error.	Wait for the file to be freed.

<i>failure-code</i>	<b>Explanation</b>	<b>User Action</b>
00000012	A file access was rejected by the security exit. This is a normal error when an invalid user ID or password is supplied. This is a user error.	Correct the user ID, the password, or both and resubmit the request.
00000013	A file was rejected because the operating system rejected the request for access to the file.	Check for message DTF6023, which describes a dynamic allocation error. Dynamic allocation is also referred to as SVC 99.
00000014	A file was rejected because DTF for IBM did not get enough memory to record control of this file.	Increase the region size of the DTF Network Manager.
00000015	A file was rejected because DTF for IBM could not identify the attributes of the file.	DTF cannot copy this file.
00000016	A logic error allowed an unsupported request to reach the manager.	Chapter 3 explains how to collect information and report problems.
00000019	The DTF component could not find a member of an existing PDS.	Correct the member name and retry the request.
00000020	The DTF component found a member of an existing PDS when the user requested the creation of a new member.	Delete the old member and retry the request.
00000023	The requested security system is not functioning. All requests are being rejected.	Chapter 3 explains how to collect information and report problems.
00000029	A file access was rejected due to a file not found. This is a normal error if a requestor attempts to open a file that does not exist.	Determine correct filespec and resubmit the request.
00000032	The request is rejected by the security exit.	Correct the user ID, the password, or both and retry the request.
00000044	A mode digit mismatch has occurred.	Remove the mode digit from the file specification or issue a DIRECTORY command to determine the correct mode digit.

<i>failure-code</i>	<b>Explanation</b>	<b>User Action</b>
00000047	A CMS file specification has been used while attempting to access a minidisk	Correct the file specification and retry the request.
00000048	A VSAM file specification has been used while attempting to access a CMS disk.	Correct the file specification and retry the request.
00000049	Wildcards are not supported for DOS or OS disks.	Determine other methods for achieving the goal of the wildcard operation.
00000050	Member names not supported for DOS or OS disks.	Correct the file specification and retry the request.
00000056	The tape operator has cancelled the request.	Contact the tape operator for more information and retry the request.
00000059	The tape operator indicated during DTF software startup is not logged in.	Contact tape operator or change startup parameters and retry the request.
00000060	The maximum number of link errors for the Node Manager has been exceeded.	The Node Manager must be stopped and restarted. Try to determine why so many link errors were detected.
00000061	A maclib member was specified for a file that does not have a file type of MACLIB.	Correct the file specification and retry the request.
00000062	A VSAM request is currently active.	Retry the request later.
00000063	HSM is not active to process the recall request.	Contact the system programmer to determine if HSM can be started.
00000064	An HSM request has failed on a locate error.	Contact the system programmer for HSM support.
00000065	An HSM request has failed on a locate error.	Contact the system programmer for HSM support.
00000066	DTF is currently using HSM to recall the indicated file for another user.	Issue a DTF INQUIRE TRANS at the console to determine the user now recalling the file. Contact the other user or retry the request later.



<i>failure-code</i>	Explanation	User Action
00000067	An HSM request has failed during a recall	Review the console for errors.
00000068	A file access has failed to specify the /HSMRECALL qualifier and the file could not be found on disk.	Add the /HSMRECALL qualifier to the file specification and retry the request.
00000069	The maximum number of users allowed by the HSM facility has been exceeded.	Try the request later.
00000071	An unsupported request has been made to supersede an HSM file.	Modify your request if possible.
00000074	An unsupported request has been made to supersede an SMS-managed GDG file.	If possible, convert the request to create the new generation of a GDG file. Follow by deleting the old generation.
00000077	A /VSAM qualifier has been used while accessing a CMS disk.	Remove the /VSAM qualifier and retry the request.
00000078	No mode letters are available to handle your request.	See your system programmer and ask that another Node Manager be added to the configuration.
00000079	The Node Manager is not authorized to issue DIRMAINT for user MDPW.	Review security considerations and modify authorizations as necessary.
00000080	The Node Manager is not authorized to link to the requested minidisk.	Review security considerations and modify authorizations as necessary.

DTF6023E

LU *vtam-lu-name* ACCESS *dtf-access-number* DYNAMIC ALLOCATION  
FAILURE CODE = *failure-code*

**Recipients:** 0

**Explanation:** This message reports an unexpected return code from the dynamic allocation call. DTF cannot create or open the file.

**User Action:** Chapter 3 explains how to collect information and report problems.

**Note:** The first four digits of *failure-code* are replaced with the dynamic allocation error code. The second four digits are replaced with the dynamic allocation information code. Consult the IBM *MVS/ESA System*

*Programming Library: Application Development Guide* manual for the meaning of these codes.

DTF6041E

LU *vtam-lu-name* ACCESS *dtf-access-number* FILE NAME *file-name*, CLOSE  
FAIL CODE = *failure-code*

**Recipients:** 0

**Explanation:** This message records a file close failure. This is an unexpected error.

**User Action:** The user action depends on the reason code; see the User Action column in the table that follows.

<i>failure-code</i>	Explanation	User Action
00000004	The file was not opened/created because DTF for IBM is shutting down. All requests are being terminated early.	Try the request later.
00000005	The CLOSE macro did not close the file. This is an unexpected error.	Chapter 3 explains how to collect information and report problems.
00000006	A logic error prevented the internal DTF for IBM resource manager from recognizing the open/create request. This is an unexpected error.	Chapter 3 explains how to collect information and report problems.
00000007	A logic error corrupted the table of available files. This is an unexpected error.	Chapter 3 explains how to collect information and report problems.
00000016	A logic error allowed an unsupported request to reach the manager.	Chapter 3 explains how to collect information and report problems.
00000017	A file was not deallocated because it was not in the chain of allocated files. This is an unexpected error.	Chapter 3 explains how to collect information and report problems.
00000018	A file was not deallocated because its use count dropped below zero.	Chapter 3 explains how to collect information and report problems.

<b>failure- code</b>	<b>Explanation</b>	<b>User Action</b>
00000033	DTF for IBM could not link to the MVS-supplied IDCAMS load module. This is a DTF Network Manager installation error.	Make the MVS-supplied IDCAMS load module available to DTF for IBM.
00000035	During a supersede operation, the new version of the file was created under a temporary name, but it was not renamed because the original file could not be renamed.	Chapter 3 explains how to collect information and report problems.
00000036	During a supersede operation, a new version of a file was created under a temporary name, and the original file was renamed with a temporary name. The renaming of the new version to the original name, however, failed.	Chapter 3 explains how to collect information and report problems.
00000037	During a supersede operation, a new version of a file was created and then renamed to the original file name. The original file name that was renamed with a temporary name, however, could not be deleted.	Chapter 3 explains how to collect information and report problems.
00000051	DOS or OS files cannot be submitted.	If possible move file to a CMS disk and retry the request.
00000052	The DTF software on the IBM system was configured with the SUBMIT capability disabled.	See your system programmer if this is a necessary feature.
00000057	A submit request was made to a batch machine that does not exist.	Retry the request using a valid batch machine.
00000058	A VSAM access request was made without the /VSAM IBM file specification qualifier.	Retry the request using the /VSAM qualifier.
00000072	The submitted file did not contain a user ID on the JOBCARD.	Correct the file and retry the submit request.

---

<b><i>failure- code</i></b>	<b>Explanation</b>	<b>User Action</b>
00000073	The submitted file did not contain a user password on the JOBCARD.	Correct the file and retry the submit request.

---

DTF6042S

LU *vtam-lu-name* ACCESS *dtf-access-number* UNEXPECTED CLOSE  
REQUEST WHILE REQUEST BLOCK BUSY

**Recipients:** 0

**Explanation:** An error occurred in the sequence of messages from the accessor. A request to close a file arrived while the session was making a different resource request. This is an unexpected error.

**User Action:** Chapter 3 explains how to collect information and report problems.

DTF6500C

ABEND HANDLER CANNOT LOCATE MCB, SYSTEM ABORTED

**Recipients:** 1

**Explanation:** An abend has occurred. DTF cannot locate the MCB to attempt recovery. A VMDUMP is taken and the DTF component terminates.

**User Action:** Chapter 3 explains how to collect information and report problems.

DTF6501C

DTF ABEND WHILE PROCESSING ABEND

**Recipients:** 0

**Explanation:** An abend has occurred while processing a previous abend. A VMDUMP is taken.

**User Action:** Chapter 3 explains how to collect information and report problems.

DTF7011E

LU *vtam-lu-name* ACCESS *dtf-access-number* FILE NAME *file-name*, DELETE  
FAIL CODE = *failure-code*

**Recipients:** 0

**Explanation:** A file delete failure occurred.

**User Action:** The user action depends on the failure code; see the User Action column in the table that follows.

<i>failure-code</i>	<b>Explanation</b>	<b>User Action</b>
00000001	The file was not opened because DTF for IBM could not get enough memory for an internal control block.	Increase the DTF component region size and retry the request.
00000002	The file was not opened because the OPEN macro failed. This is an unexpected error.	Chapter 3 explains how to collect information and report problems.
00000003	The file was not opened/created because DTF for IBM purged all activity for this session.	No action is necessary. This is a normal shutdown message.
00000004	The file was not opened/created because DTF for IBM is shutting down. All requests are being terminated early.	No action is necessary. This is a normal shutdown message.
00000005	The CLOSE macro did not close the file. This is an unexpected error.	Chapter 3 explains how to collect information and report problems.
00000006	A logic error prevented the internal DTF for IBM resource manager from recognizing the open/create request. This is an unexpected error.	Chapter 3 explains how to collect information and report problems.
00000007	A logic error corrupted the table of available files. This is an unexpected error.	Chapter 3 explains how to collect information and report problems.
00000008	The DTF for IBM resource manager rejected an invalid record format.	DTF does not allow access to files with this record format. Correct the record format and retry the request.
00000009	The DTF for IBM resource manager rejected an invalid data set organization (DSORG).	DTF does not allow access to files with this data set organization. Correct the DSORG and retry the request.
00000010	DTF for IBM internal usage flags prevent multiple requesters from sharing a file. This is a normal error if two users try to control a file exclusively.	No action is necessary. This is a normal situation.

<b>failure-code</b>	<b>Explanation</b>	<b>User Action</b>
00000011	A delete request was rejected because a different user with exclusive control allocated the file.	Wait for the file to be freed.
00000012	A file access was rejected by the security exit. This error condition occurs when you supply an invalid user ID or password.	Correct the user ID, the password, or both and retry the request.
00000013	Access to the file was rejected because the operating system rejected the request for access to the file.	Check for message DTF6023, which describes the dynamic allocation error. Dynamic allocation is also referred to as SVC 99.
00000014	Access to the file was rejected because DTF for IBM did not get the memory necessary to record control of this file.	Increase the region size of the DTF Network Manager.
00000015	Access to the file was rejected because DTF for IBM did not identify the attributes of the file.	You cannot use DTF for IBM to access this file.
00000016	A logic error allowed an unsupported request to reach the manager.	Chapter 3 explains how to collect information and report problems.
00000017	A file was not deallocated because it was not in the chain of allocated files.	Chapter 3 explains how to collect information and report problems.
00000018	A file was not deallocated because its use count dropped below zero.	Chapter 3 explains how to collect information and report problems.
00000019	DTF for IBM did not find a member of an existing PDS.	Correct the member name and retry the request.
00000020	The member was not deleted because the STOW macro failed to update the directory of the PDS.	Chapter 3 explains how to collect information and report problems.
00000023	The requested security system is not functioning. All requests are being rejected.	Chapter 3 explains how to collect information and report problems.

<i>failure-code</i>	<b>Explanation</b>	<b>User Action</b>
00000044	A mode digit mismatch has occurred.	Remove the mode digit from the file specification or issue a DIRECTORY command to determine the correct mode digit.
00000047	A CMS file specification has been used while attempting to access a minidisk.	Correct the file specification and retry the request.
00000048	A VSAM file specification has been used while attempting to access a CMS disk.	Correct the file specification and retry the request.
00000049	Wildcards are not supported for DOS or OS disks.	Determine other methods for achieving the goal of the wildcard operation.
00000050	Member names are not supported for DOS or OS disks.	Correct the file specification and retry the request. See your system programmer if this is a necessary feature.
00000056	The tape operator has cancelled the request.	Contact the tape operator for more information and retry the request.
00000060	The maximum number of link errors for the Node Manager has been exceeded.	The Node Manager must be stopped and restarted. Try to determine why so many link errors were detected.
00000061	A maclib member was specified for a file that does not have a file type of MACLIB.	Correct the file specification and retry the request.
00000062	A VSAM request is currently active.	Retry the request later.
00000063	HSM is not active to process the recall request.	Contact the system programmer to determine if HSM can be started.
00000064	An HSM request has failed on a locate error.	Contact the system programmer for HSM support.
00000065	An HSM request has failed on a locate error.	Contact the system programmer for HSM support.



<i>failure-code</i>	<b>Explanation</b>	<b>User Action</b>
00000066	DTF is currently using HSM to recall the indicated file for another user.	Issue a DTF INQUIRE TRANS at the console to determine the user now recalling the file. Contact the other user or retry the request later.
00000067	An HSM request has failed during a recall	Review the console for errors.
00000068	A file access has failed to specify the /HSMRECALL qualifier and the file could not be found on disk.	Add the /HSMRECALL qualifier to the file specification and retry the request.
00000069	The maximum number of users allowed by the HSM facility has been exceeded.	Try the request later.
00000078	No mode letters are available to handle your request.	See your system programmer and ask that another Node Manager be added to the configuration.
00000079	The Node Manager is not authorized to issue DIRMAINT for user MDPW.	Review security considerations and modify authorizations as necessary.
00000080	The Node Manager is not authorized to link to the requested minidisk.	Review security considerations and modify authorizations as necessary.

DTF7012S

LU *vtam-lu-name* ACCESS *dtf-access-number* UNEXPECTED DELETE REQUEST WHILE REQUEST BLOCK BUSY

**Recipients:** 0

**Explanation:** An error in the sequence of messages from the accessor occurred. A request to delete a file arrived while the session was making a different resource request. This is an unexpected error.

**User Action:** Chapter 3 explains how to collect information and report problems.

DTF7013E

LU *vtam-lu-name* ACCESS *dtf-access-number* DYNAMIC ALLOCATION  
FAILURE CODE = *failure-code*

**Recipients:** 0

**Explanation:** This message reports an unexpected return code from the dynamic allocation call. DTF cannot access the file to delete it.

**User Action:** Chapter 3 explains how to collect information and report problems.

**Note:** The first four digits of *failure-code* are replaced with the dynamic allocation error code. The second four digits are replaced with the dynamic allocation information code. Consult the IBM *MVS/ESA System Programming Library: Application Development Guide* manual for the meaning of these codes.

DTF7101E

LU *vtam-lu-name* ACCESS *dtf-access-number* FILE NAME *file-name*, DIR.  
FAILURE CODE = *failure-code*

**Recipients:** 0

**Explanation:** A directory failure occurred.

**User Action:** The user action depends on the failure code; see the User Action column in the table that follows.

<i>failure-code</i>	Explanation	User Action
00000001	The directory did not complete because DTF for IBM did not get enough memory for an internal control block.	Increase the DTF component region size and retry the request.
00000002	The file did not open because the OPEN macro failed. This is an unexpected error.	Chapter 3 explains how to collect information and report problems.
00000003	The directory did not complete because DTF for IBM is purging all activity for this session.	No action is necessary. This is a normal shutdown message.
00000004	The directory did not complete because DTF for IBM is shutting down. All requests are being terminated early.	No action is necessary. This is a normal shutdown message.

<i>failure- code</i>	<b>Explanation</b>	<b>User Action</b>
00000005	The CLOSE macro did not close the file. This is an unexpected error.	Chapter 3 explains how to collect information and report problems.
00000006	A logic error prevented the internal DTF for IBM resource manager from recognizing the directory request. This is an unexpected error.	Chapter 3 explains how to collect information and report problems.
00000012	The security exit rejected access to the file.	Correct the user ID, the password, or both and try to access the file again.
00000016	A logic error allowed an unsupported request to reach the manager. This is an unexpected error.	Chapter 3 explains how to collect information and report problems.
00000023	The requested security system is not functioning. All requests are being rejected. This is an unexpected error.	Chapter 3 explains how to collect information and report problems.
00000024	A volume name was not supplied for a directory request.	Add the volume name to the directory request and retry the request.
00000025	The DTF component did not obtain enough memory to report on all files.	Increase the region size of the DTF component.
00000026	DTF for IBM could not find the UCB for a volume. This error is probably caused by misspelling a volume name.	Reenter the volume name and retry.
00000027	DTF for IBM encountered a system error while accessing the VTOC of a volume. This error might be caused by a problem with the disk volume.	Try to verify the VTOC with an IBM-supplied utility. If you can verify the VTOC and the symptom persists, see Chapter 3, which explains how to collect information and report problems.
00000028	Data sets of the requested format could not be found.	No action is necessary.
00000032	The security exit rejected the request.	Correct the user ID, the password, or both and retry the request.

<i>failure-code</i>	<b>Explanation</b>	<b>User Action</b>
00000044	A mode digit mismatch has occurred.	Remove the mode digit from the file specification or issue a DIRECTORY command to determine the correct mode digit.
00000047	A CMS file specification has been used while attempting to access a minidisk.	Correct the file specification and retry the request.
00000048	A VSAM file specification has been used while attempting to access a CMS disk.	Correct the file specification and retry the request.
00000049	Wildcards are not supported for DOS or OS disks.	Determine other methods for achieving the goal of the wildcard operation.
00000050	Member names are not supported for DOS or OS disks.	Correct the file specification and retry the request.
00000056	The tape operator has cancelled the request.	Contact the tape operator for more information and retry the request.
00000060	The maximum number of link errors for the Node Manager has been exceeded.	The Node Manager must be stopped and restarted. Try to determine why so many link errors were detected.
00000061	A maclib member was specified for a file that does not have a file type of MACLIB.	Correct the file specification and retry the request.
00000062	A VSAM request is currently active.	Retry the request later.
00000063	HSM is not active to process the recall request.	Contact the system programmer to determine if HSM can be started.
00000064	An HSM request has failed on a locate error.	Contact the system programmer for HSM support.
00000065	An HSM request has failed on a locate error.	Contact the system programmer for HSM support.
00000066	DTF is currently using HSM to recall the indicated file for another user.	Issue a DTF INQUIRE TRANS at the console to determine the user now recalling the file. Contact the other user or retry the request later.

<i>failure-code</i>	<b>Explanation</b>	<b>User Action</b>
00000067	An HSM request has failed during a recall	Review the console for errors.
00000068	A file access has failed to specify the /HSMRECALL qualifier and the file could not be found on disk.	Add the /HSMRECALL qualifier to the file specification and retry the request.
00000069	The maximum number of users allowed by the HSM facility has been exceeded.	Try the request later.
00000078	No mode letters are available to handle your request.	See your system programmer and ask that another Node Manager be added to the configuration.
00000079	The Node Manager is not authorized to issue DIRMAINT for user MDPW.	Review security considerations and modify authorizations as necessary.
00000080	The Node Manager is not authorized to link to the requested minidisk.	Review security considerations and modify authorizations as necessary.

DTF9000W

KEY: *message-number* TCC: *data* LIT: *data*

**Recipients:** 0

**Explanation:** This message is a general format used when the indicated message number cannot be found in the message file.

**User Action:** Chapter 3 explains how to collect information and report problems.

**Note:** The two *data* variables are replaced with any run-time variables pointed to by the message requester.

This message indicates one of the following conditions:

- The requested message is not in the message file.
- A logic error corrupted the message ID supplied to the message routine.

Although this message is in the message file, DTF uses an internal form of the message. Its presence in the message file acts as a placeholder so that the ID is not reused.

DTF9001I  
DTF SHUTTING DOWN DUE TO SERIOUS ERROR

**Recipients:** 1

**Explanation:** DTF has entered an error state and is shutting itself down.

**User Action:** Check the log to determine the reason for the shutdown.

DTF9002E  
PROXY SUPPORT. PROXY MINIDISK *minidisk-address* NOT FOUND

**Recipients:** 1

**Explanation:** This message states that a proxy function has failed.

**User Action:** DTF has PROXY support ON and \$DTFPRXY EXEC cannot locate the minidisk containing the proxy file. Check the DTFNODE machine which displayed the message for the minidisk address in the message. If the address is not present, then take action to insure that it is available to DTF or turn PROXY support OFF.

DTF9003E  
PROXY SUPPORT. PROXY MINIDISK ACCESS FAILED

**Recipients:** 1

**Explanation:** An attempt to access a proxy file has failed.

**User Action:** An error occurred while attempting to access the proxy file. Move the proxy file to another minidisk and try again.

DTF9004E  
PROXY SUPPORT, PROXY FILE *entry-name* NOT FOUND

**Recipients:** 1

**Explanation:** An attempt to access a proxy file has failed.

**User Action:** DTF has PROXY support ON and \$DTFPRXY EXEC cannot locate the proxy file. Check the DTFNODE machine which displayed the message to see if the proxy file is present on the designated minidisk.

DTF9005E  
ID=*user-id* HAS NO MANAGER (VMSECURE ONLY)

**Recipients:** 1

**Explanation:** An attempt to access a proxy file has failed.

**User Action:** The IBM user ID supplied by the DEC user has not been assigned to a DIRECTORY. Assign the user ID to a DIRECTORY manager.

DTF9006E

ID=*user-id* IS NOT ACTIVE (VMSECURE ONLY)

**Recipients:** 1

**Explanation:** An attempt to access a proxy file has failed.

**User Action:** The IBM user ID supplied by the DEC user is not active.  
Activate the IBM user ID.

DTF9007E

NODE=*node-name*, ID=*user-id* IS NOT A VALID PROXY FOR *user-id*

**Recipients:** 1

**Explanation:** An attempt to access a proxy file has failed.

**User Action:** The IBM user ID supplied by the DEC user is not active.  
Activate the IBM user ID.

DTF9008E

*vtam-lu-name* IS NOT PERMITTED TO ACT ON USER ID *user-id*

**Recipients:** 1

**Explanation:** The DTFNODE machine does not have a GRANT command  
for authority to act on behalf of user ID.

**User Action:** Add the GRANT command to the VMSECURE CONFIG file.

**Example**

```
GRANT $VPROXY OVER *ALL TO DTFNODE
```





# B

---

## DTF for IBM Return Codes

This appendix describes all the return codes associated with the DTF for IBM software.

The DTF components other than the command processor have two categories of return codes:

- Return codes that signal errors occurring during initialization (see Section B.1).
- Return codes that signal errors occurring during operation (see Section B.2).

The DTF command processor software has four categories of return codes (see Section B.3):

- Return codes that signal errors occurring during initialization.
- Return codes that indicate full or partial success of a transfer.
- Return codes that indicate errors occurred before data records were transferred.
- Return codes that indicate errors occurred after data records started transferring.

### B.1 DTF Initialization Return Codes

Errors that occur during initialization receive error codes in the range of 100-255. Some initialization errors could also be documented in the SYSPRINT file. Table B-1 lists the DTF initialization return codes.

**Table B–1 DTF Initialization Return Codes**

Return Code	Description
100	No memory for mainline control blocks
104	No memory for trace table
108	Could not find startup parameters information
112	Subtasks not attached
116	No ESTAE
120	DTF Network Manager is not granted APF authorization
124	No file storage area
128	SYSPRINT failed
132	Missing DTFMAINI load module
134	Events table for MAINLINE failed
138	No memory for event in mainline
142	VTAM interface not initialized
146	Subsystem interface failed
150	DTF Network Manager startup parameters are not compatible with this version of DTF for IBM

## B.2 DTF Operation Error Return Codes

During execution of the DTF component, the return code reflects the severity of the messages issued. The last character of the message ID is referred to as the message type. Table B–2 shows the relationship between the message type and the return code.

**Table B–2 Operation Error Return Codes**

Return Code	Message Type	Description
00	I	An information message was issued.
04	W	A warning message was issued.
08	E	An error message was issued.
12	S	A severe error message was issued.
16	C	A catastrophic error message was issued.

## B.3 DTF Command Processor Return Codes

When the DTF command processor returns control, it sets the condition code to indicate the status. This condition code reflects the most severe error encountered by the DTF command processor during processing.

Use Table B-3 as a reference to help you determine what problem determination steps to take in response to return codes encountered during DTF command processor batch operations.

**Table B-3 Suggested Problem Determination Steps**

Return Code	Message Type	Action to Take
0	Success	No action is necessary.
1	Success	Some input was ignored. Examine the SYSPRINT file and correct the subcommands. If an ignored parameter was important, redo the job.
2	Failure	The request can be reinitiated with the RESUME subcommand.
3	Failure	The transfer completed successfully but an error occurred during the execution of the post-processing file.
4, 5, 6, or 7	Failure	The failure occurred before the transfer started. Table B-4 indicates where to start problem determination. No cleanup of files is necessary.
8 or greater	Failure	The failure occurred during a transfer. Table B-4 indicates where to do problem determination. Partial files must be cleaned up.

Table B-4 describes the specific return code values from the DTF command processor.

**Table B-4 Return Codes for DTF Command Processor Batch Jobs**

Return Code	Description
0	All of the subcommands completed normally.

(continued on next page)

**Table B-4 (Cont.) Return Codes for DTF Command Processor Batch Jobs**

<b>Return Code</b>	<b>Description</b>
1	All of the subcommands completed normally, but a warning message was issued. This code is returned if a DEFINE subcommand issues a warning message while the DTF command processor is executing in batch mode.
2	The TRANSFER or RESUME subcommand failed with a partial transfer. You can use the RESUME subcommand to restart the transfer from the last checkpoint.
3	The transfer completed successfully but an error occurred during the execution of the post-processing file.
4	DEFINE subcommands either specified invalid parameters or did not specify all of the required parameters. As a result, neither the TRANSFER nor the RESUME subcommands can correctly function. The DTF Network Manager subsystem was not contacted; the transfer was not started. The following conditions cause this code to be returned: <ul style="list-style-type: none"><li>• Missing INFILE or OUTFILE specification.</li><li>• Missing INUSER or OUTUSER specification when the DTF command processor is running in batch mode.</li><li>• Missing subsystem name.</li></ul>
5	The DTF Network Manager subsystem could not be contacted. The transfer was not started. The following conditions cause this code to be returned: <ul style="list-style-type: none"><li>• The SUBSYS keyword was not specified and the default (SUBSYSNAME in the TPT) specifies an incorrect name.</li><li>• The SUBSYS keyword was specified but it specified an incorrect subsystem name.</li><li>• The DTF Network Manager subsystem is not active.</li><li>• The DTF Network Manager subsystem is in shutdown mode.</li><li>• The DTF Network Manager subsystem is too busy to handle the request.</li></ul>

(continued on next page)

**Table B-4 (Cont.) Return Codes for DTF Command Processor Batch Jobs**

<b>Return Code</b>	<b>Description</b>
6	<p>The DTF Network Manager subsystem rejected the request. The transfer was not started. This error condition could be accompanied by a message in the DTF Network Manager SYSPRINT log explaining the error.</p> <p>The following conditions cause this code to be returned:</p> <ul style="list-style-type: none"><li>• The server node specified with the SERVER keyword has not established a session to the DTF Network Manager.</li><li>• The SERVER keyword was not specified and the DTF Network Manager had no server sessions available to handle the request.</li><li>• The request was incomplete.</li><li>• The DTF Network Manager subsystem did not have enough memory to process the request.</li><li>• An internal error condition in the DTF Network Manager subsystem caused the request to be rejected.</li></ul>
7	<p>The OpenVMS/DTF server node cannot grant the request. The transfer was not started.</p> <p>The following conditions cause this code to be returned:</p> <ul style="list-style-type: none"><li>• A recoverable transfer was requested but the client node does not support the recovery option.</li><li>• The server node cannot contact the client node specified in the DECnet file specification.</li></ul>

(continued on next page)

**Table B-4 (Cont.) Return Codes for DTF Command Processor Batch Jobs**

<b>Return Code</b>	<b>Description</b>
8	<p>The transfer was attempted but failed. The OpenVMS client node reports the reason for the failure.</p> <p>The following user errors are the most common reasons that this code is returned:</p> <ul style="list-style-type: none"><li>• File naming errors (such as file not found).</li><li>• File type errors (such as invalid record format or invalid data set organization).</li><li>• Data set name errors.</li><li>• A TSO user-requested cancel.</li></ul>

---

**Note**

---

If this error code is returned, the files involved in the transfer are in doubt. The transfer could have partially completed.

If DISP(NEW) was specified, the output file could have been created; if DISP(OLD) was specified, the output file could have been reset to the beginning of file.

---

(continued on next page)

**Table B-4 (Cont.) Return Codes for DTF Command Processor Batch Jobs**

<b>Return Code</b>	<b>Description</b>
9	<p>Contact was lost with the OpenVMS/DTF server node or DTF Network Manager subsystem during transfer processing.</p> <p>The following conditions cause this code to be returned:</p> <ul style="list-style-type: none"><li>• A line outage caused the server session to fail.</li><li>• The DTF Network Manager subsystem terminated before the transfer request could complete.</li></ul>
<hr/> <b>Note</b> <hr/>	
<p>The outcome of the transfer is in doubt. In normal situations, the server node stops the transfer as soon as contact with the DTF Network Manager is lost. Subsequently, you can use the RESUME subcommand to restart the transfer. However, there could be instances where the transfer either completes or fails just as contact is lost with the DTF Network Manager. In these cases, you must examine the log files of the dispatcher on the server node to see the actual outcome of the transfer.</p> <hr/>	
10	Reserved for future use.
11	Reserved for future use.
12	<p>Indicates that an internal error occurred within the DTF command processor. The DTF command processor cancels the current subcommand.</p> <p>[MVS] Control returns to the TSO terminal monitor program which continues to process the SYSTSIN file. If the SYSTSIN file includes additional DTF command processor subcommands, the TSO terminal monitor program issues errors for each additional subcommand in the file. In some instances, a dump could be written to the SYSUDUMP data set.</p>





# C

---

## Primary OpenVMS/DTF Messages

Most messages for the OpenVMS/DTF file transfer interface are identical to the messages used for DECnet file transfer. These messages are generated by the operating system's file utilities (such as COPY) or by the network software's file utilities (such as NFT). These messages are described in the client operating system's system messages manual or in the network software's use or guide to utilities manual.

This appendix describes those primary messages that are unique to DTF file transfers (all have abbreviated text that begins with DTF). These messages often include secondary codes which must be interpreted to obtain a secondary message. These codes are listed in Appendix D and are described in Appendix E.

---

### Note

---

The TRANSFER/DTF utility generates its own error messages. These messages are prefixed by TRANSFER/DTF and are described in Appendix E.

---

DTFACC, error accessing file; reason code %XXXXXXXX

**Explanation:** The DTF for IBM component could not access the file. The secondary status code indicates the reason for the failure. If this code cannot be translated by using the tables in Appendix D or the TRANSFER/DTF SHOW ERROR command, then the error occurred due to a dynamic allocation (SVC 99) failure on the IBM system. Refer to the *MVS/ESA System Programming Library: Application Development Guide* for more information.

**User Action:** Examine the IBM SYSPRINT log, which will contain a more detailed explanation of the error.

DTFCDDREC, error accessing CDD record; reason code %XXXXXXXX

**Explanation:** SNADTF\$FAL could not retrieve the record that was specified with the /RECORD\_DEFINITION qualifier, from the Common Data Dictionary on the OpenVMS/DTF server node.

**User Action:** Translate the code provided by using the tables in Appendix D or by using the TRANSFER/DTF SHOW ERROR command.

DTFCFGFIL, error accessing configuration file

**Explanation:** SNADTF\$FAL encountered an error accessing the server account database file on the OpenVMS/DTF server node.

**User Action:** Examine the subsequent error messages to determine the exact cause of the error.

DTFCRE, error creating file; reason code %XXXXXXXX

**Explanation:** The DTF for IBM component could not create the file. The secondary status code indicates the reason for the failure. If this code cannot be translated by using the tables in Appendix D or the TRANSFER/DTF SHOW ERROR command, then the error occurred due to a dynamic allocation (SVC 99) failure on the IBM system. Refer to the *MVS/ESA System Programming Library: Application Development Guide* for more information.

**User Action:** Examine the IBM SYSPRINT log, which will contain a more detailed explanation of the error.

DTFCVT, error converting data in record; reason code %XXXXXXXX

**Explanation:** SNADTF\$FAL could not convert the data type.

**User Action:** Translate the code provided by using the tables in Appendix D or by using the TRANSFER/DTF SHOW ERROR command. In addition, the NETSERVER.LOG file in the server account directory on the OpenVMS/DTF server node contains a more detailed explanation of the error.

DTFDEFFIL, error accessing file definition file

**Explanation:** SNADTF\$FAL encountered an error accessing the file definition database file on the OpenVMS/DTF server node.

**User Action:** Examine the subsequent error messages to determine the exact cause of the error.

DTFFALSHT, remote FAL is shutting down

**Explanation:** A file transfer or access operation could not be initiated because DTF for IBM is in the process of shutting down.

**User Action:** Contact your IBM support center staff or retry your command at a later time.

DTFNOFIL, no such file definition

**Explanation:** There is no such file definition defined in the file definition database on the OpenVMS/DTF server node.

**User Action:** Add the file definition on the OpenVMS/DTF server node using the SNA DTF Configuration utility.

DTFNOREC, no such record definition

**Explanation:** There is no such record definition in the Common Data Dictionary (CDD) on the OpenVMS/DTF server node.

**User Action:** Use the CDD DMU utility to add the required record definition to the CDD on the server node.

DTFOPRABO, operation aborted by remote operator

**Explanation:** DTF for IBM had an internal error which forced the address space to take an internal dump.

**User Action:** Contact your IBM support center staff or submit a Software Performance Report (SPR).

DTFQUASYN, syntax error in foreign file specification; %XXXXXXXXXX

**Explanation:** The IBM file specification is specified incorrectly in the command.

**User Action:** Translate the code provided by using the tables in Appendix D or by using the TRANSFER/DTF SHOW ERROR command. In addition, the NETSERVER.LOG file in the server account directory on the OpenVMS/DTF server node contains a more detailed explanation of the error.

DTFQUAVAL, invalid file name qualifier value specified; reason code  
%XXXXXXXXXX

**Explanation:** An invalid IBM file specification qualifier value is specified in the command.

**User Action:** Translate the code provided by using the tables in Appendix D or by using the TRANSFER/DTF SHOW ERROR command. In addition, the NETSERVER.LOG file in the server account directory on

the OpenVMS/DTF server node contains a more detailed explanation of the error.

DTFRDCKP, Read checkpoint reached

**Explanation:** A read checkpoint has been reached during a recoverable file transfer.

**User Action:** This message should never be seen. If you see this message and you have the proper maintenance service, you should submit a Software Performance Report (SPR) explaining the circumstances leading up to your observance of this message.

DTFSESEST, error establishing SNA session; reason code %XXXXXXXXXX

**Explanation:** SNADTF\$FAL encountered an error while establishing an SNA session with DTF for IBM software.

**User Action:** Translate the code provided by using the tables in Appendix D or by using the TRANSFER/DTF SHOW ERROR command. In addition, the NETSERVER.LOG file in the server account directory on the OpenVMS/DTF server node contains a more detailed explanation of the error.

DTFSESTER, SNA session terminated unexpectedly; reason code %XXXXXXXXXX

**Explanation:** The SNA session between DTF for IBM software and OpenVMS/DTF terminated unexpectedly.

**User Action:** Translate the code provided by using the tables in Appendix D or by using the TRANSFER/DTF SHOW ERROR command. In addition, the NETSERVER.LOG file in the server account directory on the OpenVMS/DTF server node contains a more detailed explanation of the error.

DTFTRATBL, error loading translation table; reason code %XXXXXXXXXX

**Explanation:** SNADTF\$FAL could not load the DMCS-to-EBCDIC translation table that was specified with the /TRANSLATE qualifier.

**User Action:** Translate the code provided by using the tables in Appendix D or by using the TRANSFER/DTF SHOW ERROR command.

DTFUNSTYP, unsupported data type in record; reason code %XXXXXXXXXX

**Explanation:** The record definition obtained from the CDD specified a field with a data type that is not supported by OpenVMS/DTF.

**User Action:** Translate the code provided by using the tables in Appendix D or by using the TRANSFER/DTF SHOW ERROR command.

DTFVERMIS, incompatible version of control file; reason code %XXXXXXXXXX

**Explanation:** One of the database files on the OpenVMS/DTF server node (the file definition, proxy, or server account database) is incompatible with the version of the OpenVMS/DTF product running on the OpenVMS/DTF server node.

**User Action:** Translate the code provided by using the tables in Appendix D or by using the TRANSFER/DTF SHOW ERROR command. If the problem persists, delete the database referred to in the message and use the DTF Configuration utility to recreate it.



# D

---

## Translating the OpenVMS/DTF Secondary Status Codes

This appendix lists the numeric secondary status codes you may receive when using DTF. These status codes are always received as secondary messages following a primary message. Secondary codes are reported as hexadecimal numbers.

In Digital UNIX, ULTRIX, MS-DOS, and OS/2, messages appear in a format similar to the following:

```
message-text  
STV: %X'hex-number'
```

where *message-text* is the primary message and *hex-number* is the hexadecimal secondary status code.

In OpenVMS, messages appear in a format similar to the following:

```
message-text;reason code: %X'hex-number'
```

where *message-text* is the primary message and *hex-number* is the hexadecimal secondary status code.

OpenVMS TRANSFER/DTF clients can use the TRANSFER/DTF SHOW ERROR command to obtain the message text associated with the secondary status code. All other clients must refer to Table D-1 to obtain the corresponding abbreviated ASCII message text of a particular code and then find the explanation of the abbreviated message text and suggested user action in Appendix E. The codes are arranged in numerical order. If you receive any messages that are not listed, see the OpenVMS/DTF server manager.

**Table D-1 Numerical Secondary Status Codes**

<b>Status Code</b>	<b>ASCII Text</b>
0203817A	FAIESTLIN
020381E2	ABNSESTER
020381EA	ACCINTERR
02038202	PUNOTAVA
0203820A	PUNOTSPE
02038222	INSGATRES
02038232	LOGUNIDEA
0203823A	NO_SUCACC
02038242	NO_SUCPU
0203824A	NO_SUCSES
0203825A	SESIN_USE
02038262	SESNOTAVA
0203826A	SESINUNAC
0203E7BA	SESOUTRAN
023A800A	CDDNOTINS
023A8012	CONVERMIS
023A801A	ERRACCTRA
023A8022	ERRCLOCON
023A802A	ERRCLOFIL
023A803A	ERROPECON
023A8042	ERROPEFIL
023A8052	ERRREACON
023A805A	ERRREAFIL
023A806A	FILVERMIS
023A8072	INVQUAL
023A8082	VERNUM
023A808C	BUGCHK
023A8094	UNEMBXMSG (see BUGCHK)
023A809C	UNESCRU (see BUGCHK)

(continued on next page)



**Table D-1 (Cont.) Numerical Secondary Status Codes**

<b>Status Code</b>	<b>ASCII Text</b>
023A80A3	SEENETLOG
023A80AB	SEESYSPRI
023A80B2	APPNOTAVA
023A80BA	APPNOTKNO
023A80C2	BADDATFOR
023A80CA	DYNMEMEXH
023A80D2	INVSESPAR
023A80DA	IBMDTFSHU
023A80E2	NEGBINUNA
023A80EA	NOCINDAT
023A80F2	NOTASKAVA
023A80FA	NOUSEDAT
023A8102	OUTRUSMALL
023A810A	SESLIMEXC
023A8112	VTAREFBIN
023A811A	ZERRECPAC
023A8122	ZERSENPAC
023A812A	CRC
023A8132	CVTFORERR
023A813A	CVTOVF
023A8142	CVTPRELOS
023A814A	CVTUNF
023A8152	DECLINBRO
023A815A	DECCOMERR
023A8162	DECMBXERR
023A816A	ERRCOMIBM
023A8172	EXRRCV
023A817A	FIELDNAM
023A8182	FLDOFFSET

(continued on next page)

**Table D-1 (Cont.) Numerical Secondary Status Codes**

<b>Status Code</b>	<b>ASCII Text</b>
023A818A	INCOBJNUM
023A8192	INVNCBFOR
023A819A	NEGRSPRCV
023A81A2	PARDAPCON
023A81AA	QUAVALOUT
023A81B2	QUAVALOT1
023A81BA	RECLENNEQ
023A81C2	RECNUM
023A81CA	SNAEVTNOT
023A81D2	SNASESSHU
023A81DA	SYNCH
023A81E2	TOOMANVOL
023A81EA	UNABIND
023A81F2	UNABD0
023A81FA	UNABD1
023A8202	UNABD2
023A820A	UNARAN
023A8212	UNAVAL
023A821A	UNESEQNUM
023A8222	UNESEQNM1
023A822A	UNSTYPADT
023A8232	UNSTYPB
023A823A	UNSTYPBPV
023A8242	UNSTYPBLV
023A824A	UNSTYPBU
023A8252	UNSTYPCIT
023A825A	UNSTYPDC
023A8262	UNSTYPDSC
023A826A	UNSTYPFC

(continued on next page)

**Table D-1 (Cont.) Numerical Secondary Status Codes**

<b>Status Code</b>	<b>ASCII Text</b>
023A8272	UNSTYPGC
023A827A	UNSTYPHC
023A8282	UNSTYPNRO
023A828A	UNSTYPO
023A8292	UNSTYPOU
023A829A	UNSTYPQ
023A82A2	UNSTYPQU
023A82AA	UNSTYPUNK
023A82B2	UNSTYPVAL
023A82BA	UNSTYPVT
023A82C2	UNSTYPZI
023A82CA	UNSTYPZEM
023A82D2	VALLONDSP
023A82DA	VALLONFIL
023A82E2	VALLONPAS
023A82EA	VALLONREC
023A82F2	VALLONUNI
023A82FA	VALLONUSE
023A8302	VALLONVOL
023A830C	BADLINSTA (see BUGCHK)
023A8314	EXPUNBRU (see BUGCHK)
023A831C	QUE_EMPTY (see BUGCHK)
023A8324	POSRSPRCV (see BUGCHK)
023A832C	RUISREQ (see BUGCHK)
023A8334	UNEERRMSG (see BUGCHK)
023A833C	UNEEVETYP (see BUGCHK)
023A8344	UNERETSYS (see BUGCHK)
023A834C	VALTOOLON (see BUGCHK)
023A8354	VALTOOSHO (see BUGCHK)

(continued on next page)

**Table D-1 (Cont.) Numerical Secondary Status Codes**

<b>Status Code</b>	<b>ASCII Text</b>
023A88D2	RECVSAMUNS
023A88DA	NOVSAMPWD
023A88E2	IDXLOADERR
023A88EA	VSAMSUPUNS
023A88F2	EMPTYALTIDX
023A88FA	VSAMOVRUNS
023A8902	NODUPPRI
023A890A	RFATABFUL
023A8912	CANTDORFA
023A891A	BADVSAMNAM
023A8922	VSAMEMPTY
023A892A	ERRRECPDS
023A8932	EXCRSPRCV
023A893A	NOFILSER
023A8942	NONETMEM
023A894A	NOMOREREQ
023A8952	FILOUTSRV
023A895A	NMRESSHRT
023A8962	NOWRTLNK
023A896A	NOREADLNK
023A8972	ERROPEOUT
023A897A	ERROPEVSA
023A8982	INVVALUE
023A8994	BADKEYREQ (see BUGCHK)
023A899C	INTSTRCOR (see BUGCHK)
023A89A2	BADDAPVER
023A89AA	KEYREF
023A89B2	KEYVALOUT
023A89BA	SHORTFIELD

(continued on next page)

**Table D-1 (Cont.) Numerical Secondary Status Codes**

Status Code	ASCII Text
023A89C2	TOOMANDSP
023A89CA	TOOMANKEY
023A89D2	UNRKEYWOR
023A89DA	VALLONSEC
023A89E2	VARARRSHO
023A89EC	UNSCRXNOD (see BUGCHK)
023A8CDA	BADDOSFIL
023A8CE2	BADCMSFIL
023A8CEA	MEMNOTSUP
023A8CF2	NOWILDDOS
023A8CFA	SUBNOTSUP
023A8D02	BADRECSIZ
023A8D0A	BADRECFORM
023A8D12	NOSUBDOS
023A8D1A	INVUNIT
023A8D22	OPERCAN
023A8D2A	NOBATCHID
023A8D32	ADDVSAMQ
023A8D3A	TAPOPNLGN
023A8D42	LNKERREXC
023A8D4A	NOBIOVSAM
023A8D52	INVMACLIB
023A8D5A	HSMNOTACT
023A8D62	HSMLOCERR
023A8D6A	HSMLNKERR
023A8D72	HSMINUSE
023A8D7A	HSMRECALL
023A8D82	HSMNOTCNF
023A8D8A	HSMMAXREQ

(continued on next page)

**Table D-1 (Cont.) Numerical Secondary Status Codes**

Status Code	ASCII Text
023A8D92	HSMMEMDEL
023A8D9A	HSMSUPARC
023A8DA2	SUBREQUID
023A8DAA	SUBREQPAS
023A8DB2	VMFILDEL
023A8DBA	VSAMACTIV
023A8DC2	HSMSUPGDG
023A8DCA	INVMACHDR
023A8DD2	MODDIGCON
023A8DDA	NOVSAMCMS
023A8DE2	CLOSEFAIL
023A8DEA	NOMODELET
023A8DF2	NODEDIRM
023A8DFA	NODELINK
023A8E02	ZERLENREC
023A8E22	DIAGD4FLD
023A8E6A	VALLONMDR
023A8E72	VALLONOWN
023A8E7A	VALLONBAT
023A8E82	VALLONCLA
023A8E8A	VALLONMDA
023A8E92	VALLONNULL
023A8E9A	INVALNULL
023A8EA2	VALLONMDW
023A8EAA	VALLONMDM
023A8EB2	VALLONNOD
023A8EBA	VALLONSMSD
023A8EC2	VALLONSMSM
023A8ECA	VALLONSMSS

(continued on next page)

**Table D-1 (Cont.) Numerical Secondary Status Codes**

<b>Status Code</b>	<b>ASCII Text</b>
023A8ED4	INTCRXERR
023A8EDC	TAGMSMTCH
023A8FC2	UNSTAGD
023A8FCA	UNSTAGF
023A8FD2	UNSTAGG
023A8FDA	UNSTAGH
023A8FE2	UNSTAGNL
023A8FEA	UNSTAGNR
023A8FF2	UNSTAGNU
023A8FFA	UNSTAGNZ
023A9002	UNSTAGP
023A900A	UNSTAGZ
023A9012	UNSTAGUNK
023A901A	UNSTAGVAL
023A9052	UNSTYPNLO





# E

---

## OpenVMS/DTF Messages

This appendix lists and describes all the TRANSFER/DTF messages and all the OpenVMS/DTF secondary status messages for the other DTF-supported nonrecoverable file transfer commands. Most messages for nonrecoverable DTF file transfer requests are the same messages you would receive performing DECnet file transfers. For more information on these messages, see your system messages manual or your DECnet file transfer manual.

A small number of nonrecoverable primary messages are DTF-specific and are listed in Appendix C. The DTF-specific messages frequently contain secondary status codes that must be translated to their ASCII equivalent. Users with access to the TRANSFER/DTF utility can use the TRANSFER/DTF SHOW ERROR command to get the ASCII error message. All other users must use the table in Appendix D.

All TRANSFER/DTF messages and secondary status code messages displayed with the SHOW ERROR command have the following format:

*facility-l-ident, text*

where

*facility* is the name of the facility or program that generates the message. All the messages in this appendix have the facility code SNADTF.

*I* is a severity level indicator with one of the following values:

Code	Meaning
S	Success—the action completed successfully.
I	Information—you do not need to take any further action.
W	Warning—OpenVMS/DTF may have performed some of your request.
E	Error—the output is incorrect. You may need to refer to the problem determination guide for your interconnect system or report the problem to Digital using a Software Performance Report (SPR).
F	Fatal, or severe, error—OpenVMS/DTF cannot continue with your request. You may need to refer to the problem determination guide for your interconnect system or report the problem to Digital using a Software Performance Report (SPR).

*ident* is an abbreviation of the message text.

*text* is the explanation of the message.

A sample OpenVMS/DTF message follows:

```
%SNADTF-I-ADDFIL, file definition 'DTF1' added
```

## E.1 OpenVMS/DTF Messages

The following messages are listed alphabetically according to the abbreviated message text (*ident*).

ABNSESTER, session terminated abnormally

**Explanation:** Either the link between the Gateway and IBM was lost or IBM deactivated the physical unit or the line leading to the Gateway.

**User Action:** Determine why the link was lost. Retry when the connection with IBM returns.

ACCINTERR, Gateway detected an error in the Gateway access routines

**Explanation:** This is a fatal error.

**User Action:** Copy the error messages that appear on your screen at this time and report the problem to your OpenVMS/DTF server manager.

ACCROUFAL, error from Gateway access routine, gateway unknown or unreachable,

**Explanation:** SNA Gateway is unknown or unreachable; Transport list (defined by SNA\_TRANSPORT\_ORDER logical) is defined incorrectly or Gateway/Host Name specified does not support transport selected; or TCP/IP Port (defined by SNA\_TCP\_PORT logical) does not match the remote connection TCP/IP Port.

**User Action:** Check the SNA Gateway, the SNA\_TRANSPORT\_ORDER logical, or the SNA\_TCP\_PORT logical.

ADDVSAMQ, /VSAM qualifier must be present to create or access VSAM files

**Explanation:** The /VSAM qualifier must be present in the IBM file specification to access or create VSAM files.

**User Action:** Include the /VSAM qualifier and retry the operation.

APPNOTAVA, DTF for IBM is not available (sense code %X'0801')

**Explanation:** A connection request from SNADTF\$FAL to DTF for IBM was rejected with a sense code of %X'0801'. This implies that the DTF component address space on the IBM system is currently not active.

**User Action:** Contact the IBM DTF client's system programmer and request that the DTF component address space be activated.

APPNOTKNO, incorrect application name specified (sense code %X'0806')

**Explanation:** A connection request from SNADTF\$FAL to DTF for IBM was rejected with a sense code of %X'0806'. This implies that the application name specified in the OpenVMS/DTF server account definition is not recognized by the IBM system.

**User Action:** See your OpenVMS/DTF server manager.

**Server Manager Action:** Use the SNADTFCFG SHOW SERVER\_ACCOUNT command to examine the Digital definition for the server account that you are using. Check that the application name given is the same as the VTAM APPLID that was defined for the DTF component on the IBM system. To do this, you will need to contact the IBM system programmer.

BADCMSFIL, OS/DOS file specification cannot be used on CMS disk

**Explanation:** IBM file specification is not a valid CMS file specification.

**User Action:** Review the file specification syntax and reissue the command.

BADDAPVER, bad DAP version

**Explanation:** The version of DAP implemented by DTF for IBM is not supported by SNADTF\$FAL.

**User Action:** See your OpenVMS/DTF server manager.

**Server Manager Action:** Have DTF for IBM upgraded to the same version as OpenVMS/DTF.

BADDATFOR, bad user data format (sense code %X'08260014')

**Explanation:** A connection request from SNADTF\$FAL to DTF for IBM was rejected with a sense code of %X'08260014'. This implies that DTF for IBM did not recognize the user data that SNADTF\$FAL sent in the INIT-SELF message. This error may occur whenever the version of DTF for IBM running on the IBM machine is incompatible with the version of OpenVMS/DTF running on either the VAX or the AXP.

**User Action:** See your OpenVMS/DTF server manager.

**Server Manager Action:** Ensure that DTF for IBM software is compatible with your version of OpenVMS/DTF. Compatibility information is contained in the Software Product Description (SPD) and in the documentation for the product. If the versions are compatible and the problem recurs, call the Digital support hotline or submit a Software Performance Report (SPR).

BADDOSFIL, CMS file specification cannot be used on OS/DOS disk

**Explanation:** IBM file specification is not a valid OS/DOS file specification.

**User Action:** Review the file specification syntax and reissue the command.

BADRECFORM, record format is invalid to submit the file

**Explanation:** The record format is invalid to submit the file.

**User Action:** The record size must be 80 bytes and record format must be fixed. Correct the file and resubmit.

BADRECSIZ, record size invalid to submit the file

**Explanation:** The record size is invalid to submit the file.

**User Action:** The record size must be 80 bytes and record format must be fixed. Correct the file and resubmit.

BADVSAMNAM, bad VSAM name, member name or generation version number not allowed

**Explanation:** You attempted to gain access to a VSAM file with a file specification containing a partitioned data set member name or a generation data group version number.

**User Action:** Do not specify the member name or version number when specifying the file name.

BUGCHK, internal error detected in *routine-name* at PC *xxxxxxx*

**Explanation:** An internal error has been detected in the OpenVMS /DTF software. This error is fatal and causes the running image to exit immediately. The occurrence of this message implies that the OpenVMS /DTF software is operating incorrectly. BUGCHK secondary messages are listed below along with their full message text:

BADKEYREQ bad key request state *state*  
BADLINSTA bad link state *state*  
BLKOUTRNG block type is out of range  
DECNFND internal queue empty  
EXPFRCV unexpected expedited flow message received  
EXPUNBRU expected an UNBIND RU, code %X'32', received *value*  
INSPRIV failed to enable required privileges  
INTSTRCOR internal structure corrupt  
LIBFAIL call to library routine *routine-name* failed  
MSGOUTRNG message type is out of range  
POSRSPRCV positive response received from IBM host  
QUE\_ internal queue empty  
EMPTY  
RUISREQ RU is a request  
SSFAIL call to system service *service-name* failed  
STATE job is in an invalid job state, value *value*  
UNEERRMSG unexpected error message  
UNEEVETYP unexpected event type, type *type-value*  
UNEMBXMSG unexpected DECnet mailbox message received, type *code*  
UNERETSYS unexpected return code from system routine  
UNESCRU unexpected Session Control RU received, RU code *code*

UNREVT unrecognized event occurred  
UNSCRXNOD unsupported CRX node type, type *type-value*  
VALTOOLON value *value* too long for qualifier *qualifier*  
VALTOOSHO value *value* too short for qualifier *qualifier*

**User Action:** Record this error message and all subsequent error messages associated with this error. Show them to your OpenVMS/DTF server manager.

**Server Manager Action:** Gather information on all the circumstances surrounding this error, and then report the problem to Digital by submitting a Software Performance Report (SPR) or by calling the Digital support hotline.

CANTDORFA, RFA access not allowed, use /RFA qualifier

**Explanation:** This error is reported when an attempt is made to access a VSAM indexed file using an RFA, without using the /RFA qualifier.

**User Action:** When opening the VSAM indexed file, specify the /RFA IBM file specification qualifier in the foreign file name.

CDDNOTINS, Common Data Dictionary is not installed on the OpenVMS /DTF server node

**Explanation:** The Common Data Dictionary product is not installed on the OpenVMS/DTF server node. This product is required in order to use the /RECORD\_DEFINITION qualifier.

**User Action:** See your OpenVMS/DTF server manager.

**Server Manager Action:** Install the Common Data Dictionary product on the OpenVMS/DTF server node.

CHANOTMAD, changes not made

**Explanation:** A TRANSFER/DTF SET command failed.

**User Action:** Examine the subsequent error messages to determine the reason for failure.

CLIENTCOMERR, error communicating with client node *keyword-name*

**Explanation:** This error is reported when a DTF for IBM-initiated file transfer fails to connect to the client node. The SNADTF\$DISPATCHER process could not communicate over a DECnet logical link with the remote client node.

**User Action:** See your OpenVMS/DTF server manager.

**Server Manager Action:** Examine the subsequent error messages to determine why the SNADTF\$DISPATCHER process could not establish a DECnet link with the client node.

CLOSEFAIL, could not close the file

**Explanation:** DTF for IBM could not close the output file. The most likely cause for this message is that a CMS file was created but no data was written to the new file.

**User Action:** CMS does not allow for creation of empty files. If you wish to create a CMS file, you must enter at least one record of data before closing the file. Try the operation again entering at least one record of data.

CONVERMIS, SNADTF\$MANAGER:SNADTF\$SERVER\_ACCOUNT.DAT is incompatible

**Explanation:** The server name database file on the OpenVMS/DTF server node is incompatible with the running version of the OpenVMS/DTF product.

**User Action:** See your OpenVMS/DTF server manager.

**Server Manager Action:** Delete the SNADTF\$SERVER\_ACCOUNT.DAT;\* file from the SNADTF\$MANAGER directory on the OpenVMS/DTF server node. Use the SNADTFCFG ADD SERVER\_ACCOUNT command to create a new server account database file.

CRC, network DAP level CRC check failed on DECnet logical link

**Explanation:** CRC checksums computed by SNADTF\$FAL and RMS on the OpenVMS/DTF client node did not match when compared during a file close operation.

**User Action:** The file that was created or modified may be corrupted. Repeat the file access. If the CRC error on close persists, the communication hardware is malfunctioning.

CVTFORERR, format error discovered during data conversion

**Explanation:** SNADTF\$FAL was unable to convert a field in a record between Digital and IBM formats because the input field was formatted incorrectly. This causes the file transfer to terminate at the point of failure.

**User Action:** Examine the input file to determine which field is formatted incorrectly.

CVTOVF, overflow occurred during data conversion

**Explanation:** SNADTF\$FAL was unable to convert a field in a record between Digital and IBM formats. The resulting number was too large to be converted to the floating point format of the destination system. This causes the file transfer to terminate at the point of failure.

**User Action:** Examine the input file to determine which field contains a value that is too large to be converted.

CVTPRELOS, precision lost during data conversion

**Explanation:** SNADTF\$FAL was unable to convert a field in a record between Digital and IBM formats because precision is lost when converting to the floating point format of the destination system. This causes the file transfer to terminate at the point of failure.

**User Action:** Examine the input file to determine which field is causing the error.

CVTUNE, underflow occurred during data conversion

**Explanation:** SNADTF\$FAL was unable to convert a field in a record between Digital and IBM formats because the resulting number was too small to be converted to the floating point format of the destination system. This causes the file transfer to terminate at the point of failure.

**User Action:** Examine the input file to determine which field contains a value that is too small to be converted.

DECCOMERR, DECnet communication error

**Explanation:** SNADTF\$FAL detected an error in communicating with the OpenVMS/DTF client system.

**User Action:** Examine the subsequent messages to determine the reason for the error.



DECLINBRO, DECnet link broken

**Explanation:** The DECnet link between the OpenVMS/DTF client system and SNADTF\$FAL on the server node was terminated by the client process accessing the remote file.

**User Action:** None. This is a normal condition that occurs when a file transfer is completed and the OpenVMS/DTF client system terminates the DECnet logical link to the OpenVMS/DTF server node.

DECMBXERR, DECnet mailbox read error

**Explanation:** SNADTF\$FAL was unable to read a message from the mailbox that is associated with the DECnet logical link connected to the OpenVMS/DTF client node. The error is probably caused by a lack of resources on the OpenVMS/DTF server node.

**User Action:** Examine the subsequent messages to determine the cause of the error.

DEFINTOUT, default INTERVAL value *delta-time* is less than the minimum value of *delta-time*

**Explanation:** A TRANSFER/DTF SET QUEUE command failed because the DEFAULT INTERVAL value you specified is less than the MINIMUM INTERVAL value.

**User Action:** Reissue the command specifying a DEFAULT INTERVAL value that is greater than the MINIMUM INTERVAL value.

DEFRETOU, default RETRIES value *n* is out of range [*n-n*]

**Explanation:** A TRANSFER/DTF SET QUEUE command failed because the DEFAULT RETRIES value exceeds the allowable range.

**User Action:** Reissue the command specifying a DEFAULT RETRIES value that is within the allowable range.

DEFTIMOUT, default TIME value *delta-time* is greater than the maximum of *delta-time*

**Explanation:** A TRANSFER/DTF SET QUEUE command failed because the DEFAULT TIME value is greater than the MAXIMUM TIME value.

**User Action:** Reissue the command specifying a DEFAULT TIME value that is less than the MAXIMUM TIME value.

DISERR, error communicating with server process SNADTF\$DISPATCHER

**Explanation:** A TRANSFER/DTF network job running a DTF for IBM-initiated file transfer failed because the DECnet logical link broke between it and the SNADTF\$DISPATCHER process on the OpenVMS/DTF server node.

**User Action:** Correct the network problem that caused the link to break. Then retry the file transfer operation using the DTF for IBM user interface.

DYNMEMEXH, dynamic memory exhausted (sense code %X'0826', %X'0024')

**Explanation:** DTF for IBM could not allocate the dynamic memory that is necessary to bring up an SNA session.

**User Action:** See your OpenVMS/DTF server manager.

**Server Manager Action:** Contact IBM DTF client's system programmer and ask that the SYSPRINT log for the DTF component address space be reviewed. The log should be checked for one of the following errors: DTF0202E, DTF0303E, or DTF0602E. These errors record the reason that an SNA session could not be established with DTF for IBM. Use the SYSPRINT log file and refer to Chapter 2 for a more detailed explanation of why this error has occurred.

EMPTYALTIDX, empty alternate index in VSAM file

**Explanation:** An attempt was made to open a multi-keyed VSAM file which contains an empty alternate index component.

**User Action:** Perform a BUILD INDEX operation on the MVS system.

ERRACCTRA, error accessing translation table file *file-spec*

**Explanation:** SNADTF\$FAL on the OpenVMS/DTF server node could not read the translation table from the specified file. This file name was specified either with the /TRANSLATE qualifier or indirectly through the use of a file definition.

**User Action:** Examine the subsequent error messages to determine the exact cause of the error.

ERRCLOCON, error closing server account database *file-spec*

**Explanation:** The server account database file could not be closed.

**User Action:** Examine the subsequent error messages to determine the exact cause of the error.

ERRCLOFIL, error closing file definition database *file-spec*

**Explanation:** The file definition database file could not be closed.

**User Action:** Examine the subsequent error messages to determine the exact cause of the error.

ERRCLOJOB, error closing job entry file *file-spec*

**Explanation:** The work file submitted by the TRANSFER/DTF command to the SNADTF queue could not be closed.

**User Action:** Examine the subsequent error messages to determine the exact cause of the error.

ERRCLOLOG, error closing log file *file-spec*

**Explanation:** The SNADTF symbiont could not close the job log file.

**User Action:** Examine the subsequent messages to determine the reason for the error.

ERRCLOQUE, error closing queue management file *file-spec*

**Explanation:** The queue management file could not be closed. The queue management file contains the SNADTF queue parameters.

**User Action:** Examine the subsequent error messages to determine the exact cause of the error.

ERRCOMIBM, error communicating with DTF for IBM

**Explanation:** An error occurred during communication with the DTF for IBM software.

**User Action:** Examine the subsequent messages to determine the reason for the error.

ERRDELJOB, error deleting job entry file *file-spec*

**Explanation:** The SNADTF queue symbiont did not delete the job entry file that was submitted to the queue by the TRANSFER/DTF command.

**User Action:** Examine the subsequent error messages to determine the exact cause of the error.

ERRJBC, error communicating with job controller

**Explanation:** An attempt to get information from the job controller using the \$GETQUI system service failed.

**User Action:** Examine the subsequent error messages to determine the reason for the failure.

ERROPECON, error opening server account database *file-spec*

**Explanation:** The server account database file could not be opened.

**User Action:** Examine the subsequent error messages to determine the exact cause of the error.

**Server Manager Action:** If the problem occurred because the file could not be found, use the SNADTFCFG ADD SERVER\_ACCOUNT command to create a new version of the file on the OpenVMS/DTF server node.

ERROPEFIL, error opening file definition database *file-spec*

**Explanation:** The file definition database file could not be opened.

**User Action:** Examine the subsequent error messages to determine the exact cause of the error.

**Server Manager Action:** If the problem occurred because the file could not be found, use the SNADTFCFG ADD FILE\_DEFINITION command to create a new version of the file on the OpenVMS/DTF server node.

ERROPEJOB, error opening job entry file *file-spec*

**Explanation:** The work file submitted by the TRANSFER/DTF command to the SNADTF queue could not be opened.

**User Action:** Examine the subsequent error messages to determine the exact cause of the error.

ERROPELOG, error opening log file *file-spec*

**Explanation:** The SNADTF symbiont could not open the job log file.

**User Action:** Examine the subsequent messages to determine the reason for the error.

ERROPEOUT, error opening output file *file-spec*

**Explanation:** The output file could not be opened.

**User Action:** Examine the subsequent error messages to determine the exact cause of the error.

ERROPEQUE, error opening queue management file *file-spec*

**Explanation:** The queue management file could not be opened. This file contains the SNADTF queue parameters.

**User Action:** Examine the subsequent error messages to determine the exact cause of the error.

ERROPEVSA, error opening DTF file definition file *file-spec*

**Explanation:** The DTF file definition file could not be opened.

**User Action:** Examine the subsequent error messages to determine the exact cause of the error.

ERRPARVSA, error parsing VSAM definition file

**Explanation:** The VSAM definition file cannot be parsed.

**User Action:** Examine the subsequent error messages to determine the exact cause of the error.

ERRREACON, error reading server account database *file-spec*

**Explanation:** A record could not be read from the server account database file.

**User Action:** Examine the subsequent error messages to determine the exact cause of the error.

ERRREAFIL, error reading file definition database *file-spec*

**Explanation:** A record could not be read from the file definition database file.

**User Action:** Examine the subsequent error messages to determine the exact cause of the error.

ERRREAJOB, error reading job entry file *file-spec*

**Explanation:** A record could not be read from the job entry file submitted by the TRANSFER/DTF command to an SNADTF queue.

**User Action:** Examine the subsequent error messages to determine the exact cause of the error.

ERRREAQUE, error reading queue management file *file-spec*

**Explanation:** A record could not be read from the queue management file. This file contains the SNADTF queue parameters.

**User Action:** Examine the subsequent error messages to determine the exact cause of the error.

ERRRECPDS, error recovering PDS member, member unusable due to previous failure

**Explanation:** This error is reported when DTF for IBM attempts to access a PDS member during a recovery operation. This situation occurs when DTF for IBM is unable to reposition the PDS member due to a previous MVS system error. This error is not recoverable.

**User Action:** Delete the partially transferred PDS member and restart the transfer.

ERRSUBMITTING, error encountered while submitting the file

**Explanation:** DTF encountered an error while submitting the file.

**User Action:** Examine the subsequent error messages to determine the exact cause of the error.

ERRTRUJOB, error truncating job entry file *file-spec*

**Explanation:** The SNADTF queue symbiont could not truncate records at the end of a job entry file.

**User Action:** Examine the subsequent error messages to determine the exact cause of the error.

ERRWRIJOB, error writing to job entry file *file-spec*

**Explanation:** A record could not be written to the job entry file submitted by the TRANSFER/DTF command to an SNADTF queue.

**User Action:** Examine the subsequent error messages to determine the exact cause of the error.

ERRWRIQUE, error writing to queue management file *file-spec*

**Explanation:** A record could not be written to the queue management file. This file contains the SNADTF queue parameters.

**User Action:** Examine the subsequent error messages to determine the exact cause of the error.

EXCMAXRET, maximum retry value exceeded, job terminated

**Explanation:** A TRANSFER/DTF COPY job terminated because it exceeded the number of retries specified with the COPY command or the default value specified with the queue parameters.

**User Action:** The reasons for multiple retries should be investigated. They are recorded in the job log file. The network connection may have been lost before the job could complete. In this case, reissue the COPY command and specify a higher value for the /RETRY qualifier. If the network connections are unreliable, retry the job with a smaller value for

the /CHECKPOINT\_INTERVAL qualifier. This will enable the file to be transferred in smaller parts.

EXCMAXTIM, maximum time value exceeded, job terminated

**Explanation:** A TRANSFER/DTF COPY job terminated because it exceeded the time limit specified with the COPY command or the default value specified with the queue parameters.

**User Action:** The reason for the job having exceeded its maximum time limit should be investigated. These reasons are recorded in the job log file. The network connection may have been lost before the job could complete. In this case, reissue the COPY command and specify a higher value for the /TIME qualifier. If the network connections are unreliable, retry the job with a smaller value for the /CHECKPOINT\_INTERVAL qualifier. This will enable the file to be transferred in smaller parts.

EXCRSPRCV, DTF for IBM received an exception response

**Explanation:** An error occurred when DTF for IBM attempted to send a message over the SNA network. This message is used to inform the OpenVMS user of the condition. This error may occur if the RU size is too large for one of the links in the SNA network. It may also occur due to a heavy SNA network load, thus making it a transient problem. During a recoverable copy operation, this is a fatal error.

**User Action:** Report this problem to the IBM system programmer.

EXNETSER, examine SYS\$LOGIN:NETSERVER.LOG in OpenVMS account

**Explanation:** This error is reported when a DTF for IBM-initiated file transfer fails unexpectedly. The SNADTF\$DISPATCHER process could not communicate over a DECnet logical link with the TRANSFER/DTF process that is carrying out the file transfer.

**User Action:** A NETSERVER.LOG file is created under an OpenVMS account when a DECnet logical link is established between a TRANSFER/DTF process and the SNADTF\$DISPATCHER process on the OpenVMS/DTF server node. To create the link, an IBM user specifies the node name and access control information included in the DECnet file specification string. Refer to the NETSERVER.LOG file for details as to why SNADTF\$DISPATCHER could not communicate with the TRANSFER/DTF process running under the target account.

EXRRCV, exception request received

**Explanation:** An SNA exception request RU was received from the DTF for IBM software. An exception request is an RU with an associated RH that has the SDI (sense data indicator) set.

**User Action:** See your OpenVMS/DTF server manager.

**Server Manager Action:** Recreate the error and use the SNATRACE utility to examine the message sequence that caused this error.

FAICANJOB, failed to cancel job *job-name* on queue *queue-name*

**Explanation:** The TRANSFER/DTF CANCEL JOB command failed to cancel the job *job-name* on the specific queue *queue-name*.

**User Action:** Examine the subsequent error messages to determine the reason for the failure.

FAIESTLIN, failed to establish a link to the Gateway

**Explanation:** SNADTF\$FAL could not establish a link to the SNA Gateway.

**User Action:** See your OpenVMS/DTF server manager.

**Server Manager Action:** Use the SNADTFCFG utility to check whether the gateway node was specified correctly for this server account. Make the appropriate changes and reissue the command.

FAISUBJOB, failed to submit job to queue *queue-name*

**Explanation:** The TRANSFER/DTF COPY command failed because TRANSFER/DTF was unable to submit the copy job to the SNADTF queue *queue-name*.

**User Action:** Examine the subsequent error messages to determine the reason for the failure.

FIELDNAM, attempted to translate field '*field-name*'

**Explanation:** This message gives the name of the field that caused an error during translation.

**User Action:** None. This message appears with a conversion error message.

FILOUTSRV, IBM file service worker has gone out of service without acknowledging this transfer.

**Explanation:** File service machine went out of service.

**User Action:** Report this problem to the VM system programmer.



FILVERMIS, SNADTF\$MANAGER:SNADTF\$FILE\_DEFINITION.DAT is incompatible

**Explanation:** The file definition database file on the OpenVMS/DTF server node is incompatible with the running version of the OpenVMS/DTF product.

**User Action:** See your OpenVMS/DTF server manager.

**Server Manager Action:** Delete the SNADTF\$FILE\_DEFINITION.DAT;\* file from the SNADTF\$MANAGER directory on the OpenVMS/DTF server node. Use the SNADTFCFG ADD FILE\_DEFINITION command to create a new file definition database file.

FLDOFFSET, field is at offset *byte-offset* bytes in the record

**Explanation:** This message gives the offset of the field that caused an error during translation.

**User Action:** None. This message appears with a conversion error message.

HSMINUSE, HSM recall in progress by another requester

**Explanation:** The HSM facility is recalling the specified file for another user.

**User Action:** Retry the request later or see the IBM system programmer for further assistance.

HSMLNKERR, HSM has returned a link error

**Explanation:** This is an unexpected error.

**User Action:** Contact the IBM system programmer for assistance.

HSMLOCERR, HSM has returned a locate error

**Explanation:** This is an unexpected error.

**User Action:** Contact the IBM system programmer for assistance.

HSMMAXREQ, maximum HSM recall requests are in progress

**Explanation:** The HSM facility cannot handle any more requests at this time.

**User Action:** Retry the request later or see the IBM system programmer to have the maximum number of HSM users raised.

HSMNOTACT, file is archived but HSM is not active

**Explanation:** The HSM facility on the IBM system is not currently active.

**User Action:** Contact the IBM system programmer to see if HSM can be started.

HSMNOTCNE, DTF not configured to support requested HSM recall operation

**Explanation:** The DTF for IBM software was configured with HSM support disabled.

**User Action:** Contact the IBM system programmer and see if the DTF for IBM software can be reconfigured.

HSMRECALL, file is archived NOHSMRECALL is specified or defaulted

**Explanation:** DTF encountered an archived file but the /NOHSMRECALL qualifier was either explicitly specified or was the default.

**User Action:** Specify the /HSMRECALL qualifier and retry the operation.

HSMSUPARC, DTF does not support supersede of archived file

**Explanation:** DTF for IBM does not support superseding an archived file.

**User Action:** Review the need for the operation or recall the file, supersede the file, and then archive the file.

IBMDTFSHU, DTF for IBM is in shutdown mode (sense code %X'0826', %X'0010')

**Explanation:** The file access operation cannot be initiated because DTF for IBM is in the process of shutting down.

**User Action:** Retry the operation when DTF for IBM is available for use.

IDXLOADERR, error loading alternate indexes; see MVS VSAM log

**Explanation:** The MVS system encountered an error during the loading of an alternate index for a VSAM file. The loading of the index occurs as part of the creation of a VSAM file.

**User Action:** See the MVS system programmer to get the name of the VSAM log. Examine the log to find the specific cause of the error.

INCOBJNUM, DECnet connect specified an incorrect object number - *object-number*

**Explanation:** SNADTF\$FAL was activated through a DECnet connection that was not destined for the DECnet object FAL (object number 17). This error occurs only when SNADTF\$FAL.EXE is activated through a means other than the FAL.

**User Action:** See your OpenVMS/DTF server manager.

**Server Manager Action:** Do not activate SNADTF\$FAL.EXE in any way except through the FAL DECnet object.

INSGATRES, insufficient Gateway resources for session establishment

**Explanation:** The Gateway has insufficient resources for establishing a session. The active sessions currently in the Gateway are using the total resources available.

**User Action:** Wait until some of the sessions have finished, then retry. Report problem to the Gateway manager.

INTCRXERR, internal error while processing CRX node type *node*

**Explanation:** DTF generates this error when it encounters unexpected data while processing CRX nodes.

**User Action:** See your OpenVMS/DTF server manager.

**Server Manager Action:** This error indicates a software problem. You should report this problem to Digital by submitting a Software Performance Report (SPR) or by calling the Digital support hotline.

INTERRUPT, copy interrupted due to IBM communication error

**Explanation:** The copy operation has been interrupted because of an IBM communication error.

**User Action:** See your OpenVMS/DTF server manager or the IBM system programmer.

**Server Manager Action:** Determine the source of the communication error. Chapter 5 describes tracing facilities that may help you locate the problem.

INVALNULL, invalid syntax for qualifier /NULL

**Explanation:** The value given for the IBM file specification qualifier is invalid.

**User Action:** Reenter the command and use the correct syntax. For more details check the description for the /NULL qualifier.

INVMACHDR, file type is MACLIB, but invalid MACLIB header

**Explanation:** The file type specified was MACLIB but the VM operating system has indicated that the file does not have a maclib header or that the header is invalid.

**User Action:** Determine if the file really is a maclib. If the file is not a maclib, reenter the request with the proper file type. If the file is a maclib, see the VM system programmer.

INVMACLIB, member name specified but file type is not maclib

**Explanation:** The file type specified was MACLIB but the VM operating system has indicated that the file type is not MACLIB.

**User Action:** Correct the request specifying the right file name or see the VM system programmer if the file is a maclib.

INVNCBFOR, DECnet connect received with an invalid NCB format

**Explanation:** SNADTF\$FAL was activated through a DECnet connection that was not destined for the DECnet object FAL (object number 17). The DECnet network connect block (NCB) was not in the expected format. This error occurs only when SNADTF\$FAL.EXE is activated by some means other than through FAL.

**User Action:** See your OpenVMS/DTF server manager.

**Server Manager Action:** Do not activate SNADTF\$FAL.EXE in any way other than through FAL.

INVQUAL, invalid value specified for qualifier */qualifier-name*

**Explanation:** An invalid value was specified for this IBM file specification qualifier.

**User Action:** Correct the command that specified the incorrect value and reenter the command.

INVSESPAR, invalid SNA session parameters (sense code %X'0821')

**Explanation:** An attempt to establish an SNA session with DTF for IBM was rejected with SNA sense code %X'0821'. This error can be caused by specifying a nonexistent logon mode table entry.

**User Action:** See your OpenVMS/DTF server manager.

**Server Manager Action:** Use the SNADTFCFG SHOW SERVER\_ACCOUNT command to examine the definition for the server account that you are using. Write down the logon mode table entry name associated with this server account. Contact your IBM support center staff to find out whether this logon mode table entry can be used with the DTF for IBM product.

INVUNIT, invalid unit specification

**Explanation:** Unit specification is invalid.

**User Action:** Contact the VM system programmer and get the correct unit and reissue the command.

INVVALUE, invalid value specified for keyword

**Explanation:** An invalid value was specified in the DTF file definition file.

**User Action:** Correct the line that specified the incorrect value.

JOBABORT, job aborted during execution

**Explanation:** A TRANSFER/DTF COPY job failed to complete successfully.

**User Action:** Examine the subsequent error messages to determine the reason for the failure.

KEYREF, key of reference *index-number*

**Explanation:** This message indicates which index was being used during an indexed read operation.

**User Action:** None. This message appears with a conversion error message.

KEYVALOUT, value *value* for keyword *keyword* is out of range [*n-n*]

**Explanation:** A value specified in a DTF file definition file exceeded the allowable range.

**User Action:** Modify the DTF file definition file, specifying a valid value.

LNKERREXC, link errors exceeded

**Explanation:** The link errors on the IBM system exceeded the allowable limit.

**User Action:** Notify the IBM system programmer and request that the File Manager be restarted.

LOGERR, error writing to log file *file-spec*

**Explanation:** The SNADTF symbiont could not write to the job log file.

**User Action:** Examine the subsequent messages to determine the reason for the error.

LOGUNIDEA, SSCP has deactivated the session

**Explanation:** The IBM SSCP has deactivated the session by sending a DACTLU command. Some applications deactivate sessions by deactivating the LU rather than by sending an UNBIND command.

**User Action:** Contact the IBM DTF client's system programmer or retry your command at a later time.

MAXRETOUT, maximum RETRIES value *n* would be out of range [*n-n*]

**Explanation:** A TRANSFER/DTF SET QUEUE command failed because the MAXIMUM RETRIES value exceeded the allowable range.

**User Action:** Reissue the command specifying a MAXIMUM RETRIES value that is within the allowable range.

MEMNOTSUP, Member names not supported in OS/DOS file specification

**Explanation:** Member names are not for all OS/DOS files.

**User Action:** Do not use member names in the file specification syntax and reissue the command.

MININTOUT, minimum INTERVAL value *delta-time* would be less than the minimum of *delta-time*

**Explanation:** A TRANSFER/DTF SET QUEUE command failed because the MINIMUM INTERVAL value you specified is less than the valid MINIMUM INTERVAL value.

**User Action:** Reissue the command specifying a MINIMUM INTERVAL value that is greater than the valid MINIMUM INTERVAL value.

MODDIGCON, mode digit conflict

**Explanation:** A matching file has been found but the mode digit does not match the one specified.

**User Action:** Use a directory command to obtain a file listing showing the mode digits or, if the file is unique, omit the mode digit from the DTF request.

NEGBINUNA, negotiated bind is unacceptable (sense code %X'0826', %X'0028')

**Explanation:** SNADTF\$FAL sent a negotiated BIND response to DTF for IBM that was unacceptable. More detailed information on the reason for the rejection is contained in the DTF for IBM SYSPRINT log.

**User Action:** See your OpenVMS/DTF server manager.

**Server Manager Action:** Contact the IBM DTF client's system programmer and request that the SYSPRINT log for the DTF component address space be examined. Have the system programmer look for one of the following errors: DTF0202E, DTF0303E, or DTF0602E. These errors are used to log the reason that SNADTF\$FAL could not establish an SNA session with DTF for IBM.

NEGRSPRCV, negative response received

**Explanation:** An SNA negative response RU was received from the DTF for IBM software.

**User Action:** See your OpenVMS/DTF server manager.

**Server Manager Action:** Recreate the error and use the SNATRACE utility to examine the message sequence that led to the negative response being generated.

NMRESSHRT, cannot initiate transfer; resource shortage in node manager machine.

**Explanation:** The Node Manager machine on the IBM DTF client has detected a resource shortage.

**User Action:** Notify the IBM system's system programmer.

NO\_SUCACC, access name not recognized by Gateway node

**Explanation:** You specified a nonexistent access name.

**User Action:** See your OpenVMS/DTF server manager.

**Server Manager Action:** Check with your Gateway manager to determine which access name you need.

NO\_SUCPU, PU name not recognized by Gateway node

**Explanation:** Either you or the access name you used specified a nonexistent physical unit.

**User Action:** See your OpenVMS/DTF server manager.

**Server Manager Action:** Check with your Gateway manager to determine which pu name or access name you need.

NO\_SUCSES, session address does not exist

**Explanation:** Either you or the access name you used specified a nonexistent session address.

**User Action:** See your OpenVMS/DTF server manager.

**Server Manager Action:** Check with your Gateway manager to determine which session address or access name you need.

NOBATCHID, batch machine ID is not specified or invalid

**Explanation:** Batch machine ID is not specified or not valid.

**User Action:** Contact the IBM DTF client's system programmer for the correct ID.

NOBIOVSAM, block I/O not supported for VSAM files

**Explanation:** Block I/O is not supported for VSAM files.

**User Action:** If possible, convert the file to a non-VSAM file and retry the request.

NOCINDAT, no CINIT supplied by VTAM (sense code %X'0826', %X'0008')

**Explanation:** DTF for IBM did not receive a CINIT from VTAM during session establishment.

**User Action:** See your OpenVMS/DTF server manager.

**Server Manager Action:** This error should not occur because VTAM should always supply a CINIT to DTF for IBM. This error indicates a problem in VTAM or in OpenVMS/DTF. If the IBM DTF client's system programmer suspects a problem with DTF for IBM, you should report this problem to Digital by submitting a Software Performance Report (SPR) or by calling the Digital support hotline.

NODEDIRM, Node Manager not authorized to issue dirm for userid minidisk password

**Explanation:** The DTF Node Manager on the VM system does not have the authority to issue a necessary DIRMAINT request.

**User Action:** See the IBM system programmer.

NODELINK, Node Manager not authorized to link to minidisk

**Explanation:** The DTF Node Manager on the VM system does not have the authority to link to the indicated minidisk.

**User Action:** See the IBM system programmer.



NODUPPRI, duplicate key attribute unsupported for primary keys

**Explanation:** XABSV\_DUP was specified in the primary key definition XAB.

**User Action:** Verify that the call to the RMS service was coded correctly. Alternatively, the file can be redesigned with the problem key defined as an alternate key.

NOFILSER, No IBM file service worker available to handle this transfer

**Explanation:** An error occurred when DTF for IBM attempted to send a request over to the File Manager. This message is used to inform the OpenVMS user of the condition. This error may occur if the File Manager is not started.

**User Action:** Report this problem to the VM system programmer and request that the File Manager be started.

NOJOBUSER, no jobs are running under user name *user-name*

**Explanation:** A TRANSFER/DTF SHOW JOBS/USER=*user-name* failed because there are no jobs running under the specified user name.

**User Action:** None. Informational only.

NOMODELET, no more mode letters to access file with

**Explanation:** No mode letters were available for file access.

**User Action:** See the IBM system programmer.

NOMOREREQ, IBM file service worker cannot handle any more transfer

**Explanation:** The File Manager cannot handle any more transfer requests.

**User Action:** Report this problem to the VM system programmer.

NONETMEM, Memory shortage in IBM network manager has forced it to abort the transfer.

**Explanation:** The Network Manager ran out of memory. This forced it to abort the transfer.

**User Action:** Report this problem to the VM system programmer and ask that the Network Manager be restarted.

NOREADLNK, Read link not available to minidisk

**Explanation:** Could not obtain the read link to minidisk. A possible reason is that there is already a read link to this minidisk.

**User Action:** Check if there is a read link already established to this minidisk. Reissue the command after the link is given up to the minidisk.

NOSETGEN, the SET QUEUE command cannot be used on generic queues

**Explanation:** The TRANSFER/DTF SET QUEUE command can be used only on SNADTF execution queues. It cannot be used on generic queues that supply jobs to SNADTF execution queues.

**User Action:** Reissue the command for each SNADTF execution queue that receives jobs from specified generic queues.

NOSETLOG, the SET QUEUE command cannot be used on logical queues

**Explanation:** The TRANSFER/DTF SET QUEUE command can be used only on SNADTF execution queues. It cannot be used on a logical queue that supplies jobs to an SNADTF execution queue.

**User Action:** Reissue the command on the SNADTF execution queue that receives jobs from specified logical queues.

NOSUBDOS, cannot submit OS/DOS file

**Explanation:** DTF cannot submit an OS/DOS file.

**User Action:** Review the IBM file specification and submit a CMS file.

NOSUCHDTF, no such SNADTF queue

**Explanation:** A TRANSFER/DTF command failed because the specified queue either is not an SNADTF execution queue (or a generic queue that supplies jobs to an SNADTF execution queue), or is not a logical queue assigned to an SNADTF execution queue.

**User Action:** Reissue the command with the proper queue name.

NOSUCHJOB, no such job

**Explanation:** A TRANSFER/DTF command failed because the specified job does not exist.

**User Action:** Use the proper job.

NOTASKAVA, no task available to manage session (sense code %X'0826', %X'0020')

**Explanation:** SNADTF\$FAL could not start a transfer session with DTF for IBM because all DTF component communications subtasks are at their session limits.

**User Action:** Try again later when there are fewer concurrent accesses to DTF for IBM. If the problem persists, you may want to ask the IBM DTF client's system programmer to reconfigure DTF for IBM to support more concurrent sessions.

NOTDECIBM, TRANSFER/DTF cannot be used for transferring files between DECnet nodes

**Explanation:** An attempt was made to use the TRANSFER/DTF utility to copy files from one DECnet node or TCP/IP host to another DECnet node or TCP/IP host. The TRANSFER/DTF utility can be used only if one (or both) of the input and output files is an IBM system resident file.

**User Action:** Use the DCL COPY command to copy a file within a DECnet network.

NOTSTART, *date-time*, session to DTF for IBM for server *server-account* could not be started

**Explanation:** This message is logged in the SNADTF\$DISPATCHER.LOG log file when the SNADTF\$DISPATCHER process cannot establish a control session with DTF for IBM.

**User Action:** Examine the subsequent error messages to determine why the SNADTF\$DISPATCHER process could not establish a control session with DTF for IBM.

NOUSEDAT, no user data found in CINIT (sense code %X'0826', %X'0004')

**Explanation:** DTF for IBM received a CINIT that did not contain any user data.

**User Action:** See your OpenVMS/DTF server manager.

**Server Manager Action:** This error should not occur because SNADTF\$FAL always sends user data to VTAM, then to DTF for IBM, in the INIT-SELF request. Report this problem to Digital by submitting a Software Performance Report (SPR) or by calling the Digital support hotline.

NOVSAMCMS, VSAM files cannot exist on CMS disk

**Explanation:** The /VSAM qualifier was specified on a request to access a CMS minidisk. VSAM files cannot exist on a CMS minidisk.

**User Action:** Issue the command without the VSAM qualifier or specify the correct location of the VSAM files.

NOVSAMPWD, passwords not supported for VSAM file creation

**Explanation:** This error is reported when a DTF file definition file containing passwords is used during a VSAM file creation operation.

**User Action:** Create the file without specifying passwords in the DTF file definition file entry.

NOWILDDOS, Wild cards are not supported in OS/DOS file specifications

**Explanation:** Wildcards are not supported in OS/DOS file specifications.

**User Action:** Take out the wild card from the file specification and reissue the command.

NOWRTLNK, Write link not available to minidisk

**Explanation:** Could not obtain the write link to minidisk. A possible reason is that there is already a write link to this minidisk.

**User Action:** Check if there is a write link already established to this minidisk. Reissue the command after the link is given up to the minidisk.

OPEPREREQ, OPER privilege is required to execute this command

**Explanation:** A TRANSFER/DTF command failed because the user must have OPER privilege in order to execute the command successfully.

**User Action:** See your OpenVMS/DTF server manager.

**Server Manager Action:** Use the SET PROCESS/PRIVILEGE=OPER command to enable OPER privilege and reissue the failing command. Note that you will be able to enable OPER privilege only if your OpenVMS account has been authorized to use this privilege.

OPERCAN, operator cancelled tape request

**Explanation:** Operator cancelled tape request.

**User Action:** Contact operator and inquire why the cancel was entered.

OUTRUSMALL, outbound RU size is too small (sense code %X'0826', %X'002C')

**Explanation:** The logon mode table entry that was used to establish a control session specified an outbound RU size that is too small. Control sessions require an RU size of at least 800 bytes.

**User Action:** See your OpenVMS/DTF server manager.

**Server Manager Action:** Use the SNADTFCFG MODIFY SERVER\_ACCOUNT command to specify a logon mode table entry that specifies an RU size greater than 800 bytes.

PARDAPCON, error parsing DAP configuration message

**Explanation:** The DAP configuration message received by SNADTF\$FAL from the DAP accessor (RMS) on the OpenVMS/DTF client node is incorrectly formatted. This error indicates a problem with RMS on the OpenVMS/DTF client node.

**User Action:** See your OpenVMS/DTF server manager.

**Server Manager Action:** Report this problem to Digital by submitting a Software Performance Report (SPR) or by calling the Digital support hotline.

PROVERMIS, SNADTF\$MANAGER:SNADTF\$PROXY.DAT is incompatible

**Explanation:** The OpenVMS/DTF server's proxy database is incompatible with the version of OpenVMS/DTF server software running on the server.

**User Action:** See your OpenVMS/DTF server manager.

**Server Manager Action:** Delete all old versions of the proxy database (SNADTF\$PROXY.DAT) from the SNADTF\$MANAGER directory Use a series of SNADTFCFG ADD PROXY commands to recreate the old proxy database.

PUNOTAVA, PU has not been activated

**Explanation:** The physical unit on the Gateway has not been activated by IBM.

**User Action:** Ask the system programmer on the IBM DTF client to check the line and physical unit from the IBM host and activate them if necessary. If they are activated, there may be a hardware problem between the Gateway and the IBM host.

PUNOTSPE, PU name was not specified

**Explanation:** You did not specify a physical unit name in the SNASCONNECT or the SNA\$LISTEN call, and the access name that you used did not supply one either.

**User Action:** Either explicitly supply the pu name in the parameter list or implicitly supply it through the access name.

QUAVALOT1, value for qualifier is out of range

**Explanation:** A value specified on an IBM file specification qualifier exceeded the allowable range.

**User Action:** Examine SNADTF\$MANAGER:NETSERVER.LOG on the OpenVMS/DTF server node for additional information about the reason for this error.

QUAVALOUT, value *value* for qualifier */qualifier-name* is out of range [*n-n*]

**Explanation:** A value specified in an IBM file specification qualifier exceeded the allowable range.

**User Action:** Reenter the file transfer command, specifying a valid value for the qualifier.

QUEEMPTY, all queues are empty

**Explanation:** A TRANSFER/DTF SHOW JOBS command failed because there are no jobs on any of the SNADTF queues.

**User Action:** None. Informational only.

QUETOOLON, queue name *queue-name* is too long

**Explanation:** The specified queue name is too long. The maximum length allowed for an OpenVMS queue name is 31 characters.

**User Action:** Reenter the command specifying a queue name with a valid number of characters.

QUEVERMIS, queue file *file-spec* is incompatible

**Explanation:** The queue file *file-spec* is incompatible with the running version of the OpenVMS/DTF product.

**User Action:** Delete the specified file. If you changed the queue characteristics, you will have to issue a TRANSFER/DTF SET QUEUE command to redefine those queue characteristics.

RCOPYCOM, error communicating with TRANSFER/DTF process

**Explanation:** This error is reported when a DTF for IBM-initiated file transfer fails because the logical link between SNADTF\$DISPATCHER and the TRANSFER/DTF process transferring the file breaks.

**User Action:** Examine the subsequent error messages to determine why the error occurred. This error is always a recoverable error: the DTF for IBM file transfer command can be retried and the file transfer will continue from the last checkpoint.

RCOPYMSG, invalid message received from TRANSFER/DTF process

**Explanation:** This error is reported when a DTF for IBM-initiated file transfer fails because SNADTF\$DISPATCHER receives an invalid message from the TRANSFER/DTF network process that is transferring the file.

**User Action:** The SNADTF\$DISPATCHER process on the OpenVMS/DTF server node establishes a DECnet logical link to a TRANSFER/DTF process using the node name and access control information specified in the DECnet file specification by the IBM user. A NETSERVER.LOG will be created in this OpenVMS account. This log contains additional information explaining why SNADTF\$DISPATCHER received an invalid message from this process. The most likely reason is that the LOGIN.COM in this account ran an image unconditionally (such as the FAL.EXE image). Because this image is not the SNARCOPY image, it could send DECnet messages to SNADTF\$DISPATCHER that would not be understood by SNADTF\$DISPATCHER. To solve this problem, change the LOGIN.COM so that it does not run images like FAL.EXE when the DECnet connect is for the SNARCOPY object.

RCPRIV, SNARCOPY must be installed with CMKRNL, NETMBX, SYSPRV and TMPMBX privileges

**Explanation:** The SYSSYSTEM:SNARCOPY.EXE image must be installed with the privileges listed. This error is most likely due to the OpenVMS/DTF startup command procedure not executing successfully at system startup time.

**User Action:** See your OpenVMS/DTF server manager.

**Server Manager Action:** Install the SNARCOPY image with the necessary privileges. This can be done by executing the startup command procedure from an account with system manager privileges.

(Use SYSSMANAGER:SNADTF\$STARTUP\_SERVER.COM on an OpenVMS/DTF server node. Use SYSSMANAGER:SNADTF\$STARTUP\_CLIENT.COM on an OpenVMS/DTF client node.)

RECIDXUNS, recoverable copy for indexed file is not supported

**Explanation:** This error is reported when a recoverable copy operation is attempted and the input file is an indexed file.

**User Action:** Retry the copy with the /NORECOVER qualifier.

RECLENNREQ, record definition length does not equal actual record length

**Explanation:** The record length in the file being transferred does not match the length of the record defined in the record definition that was obtained from the Common Data Dictionary (CDD).

**User Action:** Use a record definition from the CDD that has the same length as the records in the file being transferred.

RECNSUP, recoverable copies not supported by remote node

**Explanation:** This error is reported when a recoverable IBM-initiated copy operation is attempted and the remote node does not support this operation.

**User Action:** Retry the copy with the RECOVERABLE COPY set to NO in the DTF command interface.

RECNUM, record number *record-number* of the current transfer

**Explanation:** This message indicates which record was being translated when a conversion error occurred. If the transfer is part of a recovery, *record-number* is the record count from the checkpoint at which the recovery was started. If the transfer is of a complete file, then *record-number* is the same as the record number in the file.

**User Action:** None. This message appears with a conversion error message.

RECVSAMUNS, recoverable copy for VSAM file is not supported

**Explanation:** This error is reported when a recoverable copy operation is attempted and either the input file or output file is a VSAM file.

**User Action:** Retry the copy with the /NORECOVER qualifier.

RENAMEERR, error renaming file

**Explanation:** An error occurred while a temporary data file was being renamed to its permanent name.

**User Action:** Examine any subsequent error messages to determine the cause of the error. Correct the problem indicated and retry the operation.



RFATABFUL, RFA table full, close and re-open file

**Explanation:** The table created by DTF for IBM to record RFA values for an indexed VSAM file is full.

**User Action:** To empty the table, perform a file close followed by a file open.

SEENETLOG, see SNADTF\$MANAGER:NETSERVER.LOG for more information

**Explanation:** SNADTF\$FAL encountered an error that could not be fully reported to the initiator of the file access operation.

**User Action:** To look at the SNADTF\$MANAGER:NETSERVER.LOG file on the OpenVMS/DTF server node, use the TYPE command. This log file will contain a more detailed explanation of the error condition.

SEESYSPRI, see the DTF for IBM SYSPRINT log for more information (sense code %X'0826')

**Explanation:** A connection request from SNADTF\$FAL to DTF for IBM was rejected with SNA sense code %X'0826'. The DTF for IBM SYSPRINT log contains more detailed information about the reason for the rejection.

**User Action:** See your OpenVMS/DTF server manager.

**Server Manager Action:** Contact the IBM DTF client's system programmer and ask that the SYSPRINT log for the DTF component address space be reviewed. Have the system programmer look for one of the following errors: DTF0202E, DTF0303E, or DTF0602E. These errors are used to log the reason that SNADTF\$FAL could not establish an SNA session with DTF for IBM.

SESENDED, *date-time*, session to DTF for IBM for server *server-account* terminated

**Explanation:** This message is logged in the SNADTF\$DISPATCHER.LOG log file when a server session established between DTF for IBM and the SNADTF\$DISPATCHER process terminates unexpectedly.

**User Action:** Examine the subsequent error messages to determine why the SNA session terminated. The SNADTF\$DISPATCHER process will attempt to reestablish the server session each time the session SNADTF\$DISPATCHER RETRY\_INTERVAL expires. This RETRY\_INTERVAL is specified as a parameter to the SNADTF\$STARTUP\_SERVER command procedure. Users can initiate file transfers from the IBM system only when the server session is active.

SESIN\_USE, session address is already in use

**Explanation:** Someone else is using this session address.

**User Action:** See your OpenVMS/DTF server manager.

**Server Manager Action:** Retry using a different session address. If you are unsure of a valid choice, ask your Gateway system manager.

SESINUNAC, session address already in use or not activated

**Explanation:** All session addresses in the range specified by the access name are in use or are not activated.

**User Action:** Ask the IBM VTAM operator to activate more SLUs, or wait for an active one to become available.

SESLIMEXC, SNA session limit exceeded (sense code %X'0805')

**Explanation:** VTAM rejected an SNA session establishment request from OpenVMS/DTF. A VTAM subsystem was in the process of running down a previous session on this LU.

**User Action:** Retry the file access request. If the problem persists, contact the IBM DTF client's system programmer to find out why the LU is staying in this state.

SESNOTAVA, session address has not been activated

**Explanation:** The SLU has not been activated from the IBM side.

**User Action:** Ask the IBM VTAM operator to check the LU from the IBM host and activate it if necessary.

SESOUTRAN, session address value is out of range

**Explanation:** SNADTF\$FAL could not establish a session with DTF for IBM because the session address value specified by the /ACCESS\_NAME or /SESSION\_ADDRESS qualifier is out of range.

**User Action:** See your OpenVMS/DTF server manager.

**Server Manager Action:** Use the SNADTFCFG utility to check whether the access name specified for this server account has enough LUs defined. If the /SESSION\_ADDRESS qualifier is specified, then purge this value.

SESTARTED, *date-time*, session to DTF for IBM started for server *server-account*

**Explanation:** This message is logged in the SNADTF\$DISPATCHER.LOG log file when a control session is established with DTF for IBM.

**User Action:** None. This is an informational message.

SHORTFIELD, field too short for translation

**Explanation:** SNADTF\$FAL was unable to convert a field in a record between Digital and IBM formats. This error occurs when the record definition specifies a length for a field, but there is no more data left in the record to translate.

**User Action:** Examine the SNADTF\$MANAGER:NETSERVER.LOG file on the OpenVMS/DTF server node to see which record and field are the cause of the error, then modify the record.

SMSUPGDG, cannot supersede an SMS managed GDG

**Explanation:** You cannot supersede an SMS-managed GDG file.

**User Action:** Review the need for the operation or create a new generation and delete the old generation.

SNAEVTNOT, asynchronous SNA event notification

**Explanation:** The SNA session between the OpenVMS/DTF server node and DTF for IBM terminated unexpectedly because of generation of an asynchronous event.

**User Action:** Examine the subsequent messages to determine the reason for the error.

SNASESSHU, SNA session has either shut down or is shutting down

**Explanation:** This error is reported by SNADTF\$FAL when DAP messages are received from the OpenVMS/DTF client node while the SNA session is in the process of terminating.

**User Action:** None. This is the expected way for an SNA session to shut down.

SUBNOTSUP, Submit not supported

**Explanation:** Submit is not supported.

**User Action:** Contact the IBM DTF client's system programmer.

SUBREQPAS, Security requires /PASSWORD on SUBMIT

**Explanation:** Security on the IBM system is enabled and you must supply a user ID and password for batch submit requests.

**User Action:** Resubmit the request supplying the password information.

SUBREQUID, Security requires /USERID on SUBMIT

**Explanation:** Security on the IBM system is enabled and you must supply a user ID and password for batch submit requests.

**User Action:** Resubmit the request supplying the user ID information.

SYNCH, DAP synchronization error (expected configuration message)

**Explanation:** SNADTF\$FAL received an unexpected DAP message from the DAP accessor (RMS) on the OpenVMS/DTF client node. This error indicates a problem with RMS on the OpenVMS/DTF client node or SNADTF\$FAL on the OpenVMS/DTF server node.

**User Action:** See your OpenVMS/DTF server manager.

**Server Manager Action:** Report this problem to Digital by submitting a Software Performance Report (SPR) or by calling the Digital support hotline.

TAGSMATCH, tag did not match those defined in VARIANTS OF statement

**Explanation:** DTF was unable to determine which VARIANT clause to use because the tag in the record did not match a tag in the VARIANTS OF statement.

**User Action:** Examine the SNADTF\$MANAGER:NETSERVER.LOG file on the OpenVMS/DTF server node to determine which record and field caused the error. Also, check the CDD definition to be sure the VARIANTS OF and VARIANTS definitions were properly coded.

TAPOPNLGN, tape operator not logged in to process request

**Explanation:** The IBM tape operator was not logged in when your request reached the IBM system.

**User Action:** Notify the IBM tape operator of your need for assistance and retry the operation.

TOOMANDSP, too many values for qualifier /DSPASSWORD

**Explanation:** Too many data set passwords were specified in the parameter list for the IBM file specification qualifier /DSPASSWORD.

**User Action:** Reenter the command specifying fewer than 32 data set passwords.

TOOMANKEY, too many values for qualifier /KEY

**Explanation:** Too many key position/key size pairs were specified in the parameter list for the IBM file specification qualifier /KEY.

**User Action:** Reenter the command specifying fewer than 255 key position/key size pairs.

TOOMANVOL, too many values for qualifier /VOLUME

**Explanation:** Too many volume names were specified in the parameter list for the IBM file specification qualifier /VOLUME.

**User Action:** Reenter the command specifying fewer than 42 volume names.

UNABD0, unacceptable BIND image, byte *n*, field name *field-name*

**Explanation:** An unacceptable BIND image was received from the IBM system. The message gives the byte number in the BIND image that was unacceptable and a symbolic name for the field represented by that byte. Note that the first byte in the BIND RU is byte 0.

**User Action:** See your OpenVMS/DTF server manager.

**Server Manager Action:** Refer to the IBM manual *SNA Reference Summary* for information on the fields in the BIND image. The most likely reasons for the error are:

1. The SNA session was established to a VTAM application other than DTF for IBM.
2. An invalid logon mode table entry was used to establish the SNA session.

UNABD1, unacceptable BIND image, byte *n*, bit *n*, field name *field-name*

**Explanation:** An unacceptable BIND image was received from the IBM system. The message gives the byte number (and the bit number within that byte) in the BIND image that was unacceptable and a symbolic name for the field represented by that bit. Note that the first byte in the BIND RU is byte 0 and that the bit number is given in IBM notation. That is, the most significant bit in a byte is bit 0; the least significant bit is bit 7.

**User Action:** See your OpenVMS/DTF server manager.

**Server Manager Action:** Refer to the IBM manual *SNA Reference Summary* for information on the fields in the BIND image. The most likely reasons for the error are:

1. The SNA session was established to a VTAM application other than DTF for IBM.

2. An invalid logon mode table entry was used to establish the SNA session.

UNABD2, unacceptable BIND image, byte *n*, bits *n-m*, field name *field-name*

**Explanation:** An unacceptable BIND image was received from the IBM system. The message gives the byte number (and the bit numbers within that byte) in the BIND image that was unacceptable and a symbolic name for the field represented by those bits. Note that the first byte in the BIND RU is byte 0 and that the bit numbers are given in IBM notation. That is, the most significant bit in a byte is bit 0; the least significant bit is bit 7.

**User Action:** See your OpenVMS/DTF server manager.

**Server Manager Action:** Refer to the IBM manual *SNA Reference Summary* for information on the fields in the BIND image. The most likely reasons for the error are:

1. The SNA session was established to a VTAM application other than DTF for IBM.
2. An invalid logon mode table entry was used to establish the SNA session.

UNABIND, unacceptable BIND image

**Explanation:** An unacceptable BIND image was received from the IBM system.

**User Action:** See your OpenVMS/DTF server manager.

**Server Manager Action:** Examine the NETSERVER.LOG file in the SNADTF\$MANAGER directory on the OpenVMS/DTF server node to determine the reason for the error. This log file will contain more detailed messages concerning the incorrect field in the BIND image.

UNARAN, needed value in range '%X'hex-number' to '%X'hex-number'', received '%X'hex-number'

**Explanation:** A value was received in a BIND image that was out of range. The particular incorrect BIND image field is reported in the UNABIND message.

**User Action:** See your OpenVMS/DTF server manager.

**Server Manager Action:** Examine the NETSERVER.LOG file in the SNADTF\$MANAGER directory on the OpenVMS/DTF server node to determine the reason for the error. This log file will contain more detailed messages concerning the incorrect field in the BIND image.

UNAREQJOB, unable to requeue job *job-name* (entry *n*, on queue *queue-name*) for user *user-name*

**Explanation:** The SNADTF queue symbiont could not requeue a job after a recoverable file transfer error.

**User Action:** See your OpenVMS/DTF server manager.

**Server Manager Action:** This error indicates that there is a problem in communications between the SNADTF queue symbiont and the job controller. You should gather all the pertinent information surrounding the occurrence of this error and submit a Software Performance Report (SPR). You can also call the Digital support hotline.

UNAAVAL, expected *%X'hex-number'*, received *%X'hex-number'*

**Explanation:** An invalid value was received in an SNA BIND image. The particular incorrect BIND image field is reported in the UNABIND message.

**User Action:** See your OpenVMS/DTF server manager.

**Server Manager Action:** Examine the NETSERVER.LOG file in the SNADTF\$MANAGER directory on the OpenVMS/DTF server node to determine the reason for the error. This log file will contain more detailed messages concerning the incorrect field in the BIND image.

UNESEQNM1, unexpected sequence number received

**Explanation:** SNADTF\$FAL received a request RU with an invalid sequence number from DTF for IBM.

**User Action:** Examine the SNADTF\$MANAGER:NETSERVER.LOG file on the OpenVMS/DTF server node to determine the reason for the error. This log file will contain more detailed messages describing the reason for the error.

UNESEQNUM, unexpected sequence number *%X'hex-number'*, expected *%X'hex-number'*

**Explanation:** SNADTF\$FAL received a request RU with an invalid sequence number from DTF for IBM. This message indicates the sequence number that was received in the message and the sequence number that was expected.

**User Action:** See your OpenVMS/DTF server manager.

**Server Manager Action:** Recreate the error and use the SNATRACE utility to examine the message sequence that led to the error. A possible cause of the error is that the SNA network lost a message.

UNRKEYWOR, unrecognized keyword - check validity and spelling

**Explanation:** You either misspelled a keyword or placed the keyword in the wrong section of the DTF file definition file.

**User Action:** Edit the DTF file definition file to correct the spelling or placement.

UNSTAGD, unsupported tag data type: D\_floating

UNSTAGF, unsupported tag data type: F\_floating

UNSTAGG, unsupported tag data type: G\_floating

UNSTAGH, unsupported tag data type: H\_floating

UNSTAGNL, unsupported tag data type: left separate numeric

UNSTAGNR, unsupported tag data type: right separate numeric

UNSTAGNU, unsupported tag data type: unsigned numeric

UNSTAGNZ, unsupported tag data type: zoned numeric

UNSTAGP, unsupported tag data type: packed decimal

UNSTAGUNK, unsupported tag data type: unknown

UNSTAGVAL, unknown tag data type value is *n*

UNSTAGZ, unsupported tag data type: undefined

**Explanation:** The record definition obtained from the Common Data Dictionary (CDD) specified a field with a data type that is not supported as a VARIANTS OF tag by the OpenVMS/DTF product. In the case of UNSTAGVAL, the value of *n* is a number used for the internal representation of the data type.

**User Action:** Use a record definition that contains only supported data types for tag variables.

UNSTYPADT, unsupported data type: absolute date and time

UNSTYPB, unsupported data type: byte

UNSTYPBLV, unsupported data type: Bound Label Value

UNSTYPBPV, unsupported data type: Bound Procedure Value



UNSTYPBU, unsupported data type: unsigned byte

UNSTYPCIT, unsupported data type: COBOL Intermediate Temporary

UNSTYPDC, unsupported data type: D\_floating complex

UNSTYPDSC, unsupported data type: descriptor

UNSTYPFC, unsupported data type: F\_floating complex

UNSTYPGC, unsupported data type: G\_floating complex

UNSTYPHC, unsupported data type: H\_floating complex

UNSTYPNLO, unsupported data type: numeric string, left overpunched sign

UNSTYPNRO, unsupported data type: numeric string, right overpunched sign

UNSTYPO, unsupported data type: octaword

UNSTYPOU, unsupported data type: unsigned octaword

UNSTYPQ, unsupported data type: quadword

UNSTYPQU, unsupported data type: unsigned quadword

UNSTYPUNK, unsupported data type, data type is unknown

UNSTYPVAL, unknown data type value is *n*

UNSTYPVT, unsupported data type: varying character-coded text

UNSTYPZEM, unsupported data type: procedure entry mask

UNSTYPZI, unsupported data type: sequence of instructions

**Explanation:** The record definition obtained from the Common Data Dictionary (CDD) specified a field with a data type that is not supported by the OpenVMS/DTF product. In the case of UNSTYPVAL, the value of *n* is a number used for the internal representation of the data type.

**User Action:** Use a record definition that contains only supported data types.

USESADTF, invalid job entry file submitted to queue *queue-name*

**Explanation:** A file was submitted to an SNADTF queue that was not formatted correctly. The most likely cause of this error is use of the SUBMIT command to submit a file to an SNADTF execution queue. The only correct way to submit a file to an SNADTF execution queue is with the TRANSFER/DTF COPY command.

**User Action:** Use the TRANSFER/DTF COPY command to submit files to SNADTF execution queues.

VALLONBAT, value too long for qualifier /BATCHID

VALLONCLA, value too long for qualifier /CLASS

VALLONDSP, value too long for qualifier /DSPASSWORD

VALLONFIL, value too long for qualifier /FILE\_DEFINITION

VALLONMDA, value too long for qualifier /MDMADDRESS

VALLONMDM, value too long for qualifier /MDMPASSWORD

VALLONMDR, value too long for qualifier /MDRPASSWORD

VALLONMDW, value too long for qualifier /MDWPASSWORD

VALLONNULL, value too long for qualifier /NULL

VALLONOWN, value too long for qualifier /OWNERID

VALLONPAS, value too long for qualifier /PASSWORD

VALLONREC, value too long for qualifier /RECORD\_DEFINITION

VALLONSEC, value too long for qualifier /SECURITY\_DATA

VALLONSMSD, value too long for qualifier /SMSDCCLASS

VALLONSMSM, value too long for qualifier /SMSMCLASS

VALLONSMSS, value too long for qualifier /SMSSCLASS

VALLONUNI, value too long for qualifier /UNIT

VALLONUSE, value too long for qualifier /USERID

VALLONVOL, value too long for qualifier /VOLUME

**Explanation:** The value given for the IBM file specification qualifier is too long.

**User Action:** Reenter the command that caused the error, using a shorter qualifier value.

VARARRSHO, variable length array too short

**Explanation:** SNADTF\$FAL was unable to convert a variable length array in a record between Digital and IBM formats. This error occurs when the record is too short to contain the number of elements indicated by the tag variable field.

**User Action:** Examine the SNADTF\$MANAGER:NETSERVER.LOG file on the OpenVMS/DTF server node to see which record and field are the cause of the error. Also examine the CDD definition to see which field is the tag variable field for the variable length array.

VERNUM, file version is *Vn.n.n*, *Vn.n.n* is needed

**Explanation:** This is a submessage of a message reporting that a database file is incompatible with the running version of OpenVMS/DTF. This submessage reports the version level of the database file and the version number that the product expected.

**User Action:** Refer to the user action specified for the top-level error message.

VMFILDEL, VM file has been deleted while user was linked read to the disk

**Explanation:** A VM file has been deleted while the user was reading a file on a minidisk using the minidisk read password.

**User Action:** Determine the user who deleted the file. See the IBM DTF client's system programmer.

VSAMACTIV, VSAM access is already active

**Explanation:** A VSAM request is currently active on the IBM VM system.

**User Action:** Retry the request later or contact the IBM system programmer who can help you determine who the active user is.

VSAMEMPTY, cannot open an empty VSAM file for read only access

**Explanation:** This error is reported when you attempt to access an empty VSAM file.

**User Action:** Open the file with read and write access or ensure that the file is not empty.

VSAMOVRUNS, overlay on VSAM sequential file not supported

**Explanation:** The IBM file specification qualifier /OVERLAY was used during an attempt to transfer an OpenVMS file to an IBM VSAM file.

**User Action:** Retry the transfer with a new VSAM file as the destination.

VSAMSUPUNS, supersede on VSAM files not supported

**Explanation:** The IBM file specification qualifier /SUPERSEDE was used during an attempt to transfer an OpenVMS file to an IBM VSAM file.

**User Action:** Retry the transfer without the /SUPERSEDE qualifier, or create a new VSAM file.

VTAREFBIN, VTAM refused to send a BIND to the LU (sense code %X'0826', %X'000C')

**Explanation:** DTF for IBM attempted to send a BIND to OpenVMS/DTF. VTAM rejected this attempt.

**User Action:** See your OpenVMS/DTF server manager.

**Server Manager Action:** Contact the IBM DTF client's system programmer and ask that the SYSPRINT log for the DTF component address space be reviewed. Have the system programmer look for one of the following errors: DTF0202E, DTF0303E, or DTF0602E. The error logged in addition to this error will give more information concerning why VTAM rejected the BIND attempt.

WRKFILMIS, *work-file* is incompatible

**Explanation:** A work file has been found that is incompatible with the OpenVMS/DTF server software.

**User Action:** Resubmit the request contained in the work file.

ZERLENREC, can't write zero length records to this file

**Explanation:** A zero length record was encountered in the input file while writing to a file. If transferring to a VM system, CMS files cannot contain zero length records.

**User Action:** Use the /NULL qualifier as described in the *Digital SNA Data Transfer Facility for OpenVMS Use* manual.

ZERRECPAC, zero primary receive pacing not allowed (sense code %X'0826', %X'001C')

**Explanation:** The VPACING value for the VTAM APPLID definition specified a receive pacing value of 0. This is not a valid value.

**User Action:** Ask the IBM DTF client's system programmer modify the DTF for IBM APPLID definition to specify a nonzero VPACING value.

ZERSENPAC, zero primary send pacing not allowed (sense code %X'0826', %X'0018')

**Explanation:** The logon mode table entry that was used to establish the SNA session specified zero for the send pacing value.

**User Action:** See your OpenVMS/DTF server manager.

**Server Manager Action:** Use the SNADTFCFG MODIFY SERVER\_ACCOUNT command to specify a logon mode table entry with a nonzero send pacing value.

## E.2 DTF for IBM Messages from MVS Systems

The IBM MVS system may send you a DTF error message related to VSAM file creation that does not have a corresponding RMS message. To display the text associated with these messages, check the VTAM error log file created during VSAM file creation. If this facility is active on your system, you can copy this file from the MVS system using the DCL COPY or TYPE command.

The DTF for IBM software allows all VSAM file creation commands and messages to be recorded in a generation data group (GDG) file. This log file contains all utility control cards and messages which were used to create and initialize the VSAM files. The control cards are for the VSAM Access Method Services (IDCAMS) utility. A description of the control cards can be found in the manual, *MVS/DFP Access Method Services Reference*. Error messages written by IDCAMS begin with the characters "IDC." An explanation of these messages can be found in the *MVS System Messages* manual.

This facility is activated if the VSAMLOG option is set in the DTF component default values table or the MVS operator dynamically modifies this option using a console command. If the VSAMLOG option is active, then every request to create a VSAM file results in a new generation of the VSAM log file. The name of this file can be changed by the MVS support staff when customizing the default values table. The VSAMLOGNAME parameter determines the base GDG name. DTF.VSAMLOG is the default base name.

When trying to copy the error log from the MVS system, the GDG name must indicate the version of the requested file. Version numbers for GDG files are appended to the base GDG name. The GDG version number is enclosed in parentheses and can be one of the following:

- 0 (for the most recent version)
- -*n* (for a previous version, where *n* is a number between 1 and 255)

For example:

DTF.VSAMLOG(0) indicates the newest version of this file.

DTF.VSAMLOG(-4) indicates a version that is 4 generations old.

GDG files can also be specified by their absolute name. When you use the DIRECTORY command, the GDG file name is returned in this format. This form of the GDG name does not use the previously explained method to indicate a version number. Instead, an eight-character name is appended to the base GDG name to indicate the version number.

For example:

DTF.VSAMLOG.GnnnnV00, where *nnnn* indicates the absolute number assigned to this generation.

---

# Index

## A

---

Abend dumps  
using to resolve DTF problems, 3-3

## C

---

CLOSE command  
*See* DTF Network Manager commands  
Correlating RMS and DTF for IBM  
messages, E-45

## D

---

Data set  
SNAPDUMP, 3-6  
DEBUG  
*See* DTF Network Manager qualifiers  
DTF component  
DEBUG mode, 3-6  
SNAPDUMP, 3-6  
DTF for IBM errors  
installation, 2-5  
DTF for IBM messages, E-45  
DTF Network Manager command qualifiers  
DEBUG, 4-5  
DUMP, 4-5  
EXTRACE, 4-4  
IMMEDIATE, 4-7  
INTERCONN, 4-3  
NET, 4-3  
PROXY, 4-5  
QUIESCE, 4-7  
SERVER, 4-4

DTF Network Manager command qualifiers  
(cont'd)

TRACE, 4-6  
TRANSFER, 4-4  
VSAMLOG, 4-7

DTF Network Manager commands

CLOSE, 4-7  
INQUIRE, 4-3  
SET, 4-4

DUMP

*See* DTF Network Manager qualifiers

## E

---

Error messages

VSAM file creation, E-45

Errors

DTF for IBM software, 2-8  
gathering information for reporting, 3-1  
installation, 2-5  
isolating DTF for IBM installation errors,  
2-5  
isolating in DTF for IBM software, 2-8  
isolating in OpenVMS/DTF software, 2-8  
isolating OpenVMS/DTF installation  
errors, 2-7  
OpenVMS/DTF software, 2-8  
using abend dumps to solve, 3-3  
using external trace to solve, 3-4  
using IDCAMS output to solve, 3-7  
using internal trace table to solve, 3-3  
using SYSPRINT file to solve, 3-2

External trace

using to resolve DTF problems, 3-4

EXTRACE  
*See* DTF Network Manager qualifiers

---

## I

IDCAMS output  
IDCAMOUT file, 3-8  
VSAMLOG option, 3-8, 3-9  
using to resolve DTF problems, 3-7

IMMEDIATE  
*See* DTF Network Manager qualifiers

INQUIRE command  
*See* DTF Network Manager commands

INTERCONN  
*See* DTF Network Manager qualifiers

Internal trace table  
using to resolve DTF problems, 3-3

---

## M

Master console, 4-1  
interface, 4-1  
using, 4-1

Messages, A-1

---

## N

NET  
*See* DTF Network Manager qualifiers

---

## O

OpenVMS/DTF errors  
installation, 2-5  
OpenVMS/DTF messages, E-2  
OpenVMS/DTF problems, 5-1

---

## P

Problem determination, 5-1  
Problems  
caused during use, 2-2  
isolating, 2-1

PROXY  
*See* DTF Network Manager qualifiers

---

## Q

QUIESCE  
*See* DTF Network Manager qualifiers

---

## R

Return codes, B-1  
from DTF command processor, B-3  
from DTF Network Manager initialization,  
B-1  
from DTF Network Manager operation,  
B-2

---

## S

SERVER  
*See* DTF Network Manager qualifiers

SET command  
*See* DTF Network Manager commands

SNAPDUMP data set, 3-6

SYSPRINT file  
using to resolve DTF problems, 3-2

---

## T

TRACE  
*See* DTF Network Manager qualifiers

TRANSFER  
*See* DTF Network Manager qualifiers

Troubleshooting OpenVMS/DTF problems,  
5-1

---

## U

Usage errors  
isolating DTF for IBM errors, 2-2  
isolating OpenVMS/DTF errors, 2-3



## V

---

VSAM file creation

error messages, E-45

VSAMLOG

*See* DTF Network Manager qualifiers

