

---

# HP OpenVMS System Management Utilities Reference Manual: M–Z

Order Number: BA555-90009

**June 2010**

This document describes reference information for System Management utilities used with the OpenVMS Alpha and Integrity server operating systems.

**Revision/Update Information:** This manual supersedes the *HP OpenVMS System Management Utilities Reference Manual: M–Z*, OpenVMS Version 8.3.

**Software Version:** OpenVMS Version 8.4 for Integrity servers  
OpenVMS Alpha Version 8.4

**Hewlett-Packard Company**  
**Palo Alto, California**

---

© Copyright 2010 Hewlett-Packard Development Company, L.P.

Confidential computer software. Valid license from HP required for possession, use or copying. Consistent with FAR 12.211 and 12.212, Commercial Computer Software, Computer Software Documentation, and Technical Data for Commercial Items are licensed to the U.S. Government under vendor's standard commercial license.

The information contained herein is subject to change without notice. The only warranties for HP products and services are set forth in the express warranty statements accompanying such products and services. Nothing herein should be construed as constituting an additional warranty. HP shall not be liable for technical or editorial errors or omissions contained herein.

Intel and Itanium are trademarks or registered trademarks of Intel Corporation or its subsidiaries in the United States and other countries.

ZK6259

The HP OpenVMS documentation set is available on CD-ROM.

This document was prepared using DECdocument, Version 3.3-1B.

---

# Contents

<b>Preface</b> .....	xv
<b>1 Monitor Utility</b>	
1.1 MONITOR Description .....	1-1
1.2 MONITOR Usage Summary .....	1-3
1.3 MONITOR Commands .....	1-4
ALIGN (Integrity servers only) .....	1-5
CONVERT .....	1-6
EXECUTE (@) .....	1-7
EXIT .....	1-8
HELP .....	1-9
INITIALIZE .....	1-10
MONITOR .....	1-11
MONITOR ALL_CLASSES .....	1-17
MONITOR CLUSTER .....	1-19
MONITOR DECNET .....	1-24
MONITOR DISK .....	1-26
MONITOR DLOCK .....	1-29
MONITOR FCP .....	1-32
MONITOR FILE_SYSTEM_CACHE .....	1-34
MONITOR IO .....	1-38
MONITOR LOCK .....	1-40
MONITOR MODES .....	1-42
MONITOR MSCP_SERVER .....	1-46
MONITOR PAGE .....	1-48
MONITOR PROCESSES .....	1-50
MONITOR RLOCK .....	1-56
MONITOR RMS .....	1-58
MONITOR SCS .....	1-62
MONITOR STATES .....	1-66
MONITOR SYSTEM .....	1-70
MONITOR TIMER .....	1-74
MONITOR TRANSACTION .....	1-76
MONITOR VECTOR .....	1-79
SET DEFAULT .....	1-81
SHOW DEFAULT .....	1-82

## 2 MSA Utility

2.1	MSA Utility Usage Summary	2-1
2.1.1	Required Privileges	2-1
2.1.2	Restrictions	2-1
2.2	MSA Utility Commands	2-2
	ACCEPT UNIT	2-3
	ADD UNIT	2-4
	DELETE UNIT	2-7
	EXIT	2-8
	FLASH FIRMWARE	2-9
	HELP	2-10
	LOCATE	2-11
	READ FIRMWARE	2-13
	RESET THIS_CONTROLLER	2-14
	RESET OTHER_CONTROLLER	2-15
	SCAN ALL	2-16
	SET CONTROLLER	2-17
	SET GLOBALS	2-18
	SET UNIT	2-20
	SHOW CONNECTIONS	2-25
	SHOW CONTROLLER	2-26
	SHOW DISKS	2-29
	SHOW GLOBALS	2-32
	SHOW PROFILE	2-33
	SHOW OTHER_CONTROLLER	2-34
	SHOW THIS_CONTROLLER	2-35
	SHOW UNIT	2-36
	SHOW UNITS	2-37
	SHOW VERSION	2-38
	START RECOVER	2-39

## 3 Point-to-Point Utility

3.1	PPPD Description	3-1
3.2	PPPD Usage Summary	3-1
3.3	PPPD Commands	3-2
	CONNECT	3-3
	DIAL_OUT	3-4
	DISCONNECT	3-6
	EXIT	3-7
	HELP	3-8
	SET	3-9
	SHOW	3-13

## 4 POLYCENTER Software Installation Utility (PCSI)

4.1	PRODUCT Introduction .....	4-1
4.2	PRODUCT Commands .....	4-2
	ANALYZE PDB .....	4-4
	CONFIGURE .....	4-6
	COPY .....	4-10
	DELETE RECOVERY_DATA .....	4-15
	EXTRACT FILE .....	4-17
	EXTRACT PDF .....	4-21
	EXTRACT PTF .....	4-25
	EXTRACT RELEASE_NOTES .....	4-29
	FIND .....	4-33
	INSTALL .....	4-36
	LIST .....	4-42
	PACKAGE .....	4-46
	RECONFIGURE .....	4-51
	REGISTER PRODUCT .....	4-57
	REGISTER VOLUME .....	4-62
	REMOVE .....	4-64
	SHOW HISTORY .....	4-66
	SHOW OBJECT .....	4-69
	SHOW PRODUCT .....	4-72
	SHOW RECOVERY_DATA .....	4-75
	SHOW UTILITY .....	4-77
	UNDO PATCH .....	4-78

## 5 SAS Controller

5.1	SAS Description .....	5-1
5.2	Integrated RAID .....	5-1
5.2.1	Integrated Mirroring .....	5-1
5.2.2	Global Hot Spare Capability .....	5-2
5.3	SAS Utility Usage Summary .....	5-2
5.4	Restrictions .....	5-2
5.5	Additional Information .....	5-3
5.6	SAS Utility Commands .....	5-3
	ADD UNIT .....	5-4
	DELETE DISK .....	5-6
	DELETE UNIT .....	5-7
	EXIT .....	5-8
	SET CONTROLLER .....	5-9
	SET DISK .....	5-10
	SET UNIT .....	5-11
	SHOW CONTROLLER .....	5-13
	SHOW DISK .....	5-14
	SHOW ENCLOSURE .....	5-15
	SHOW EXPANDER .....	5-16
	SHOW PHY .....	5-17

SHOW UNIT .....	5-18
SHOW VERSION .....	5-19

## 6 SCA Control Program Utility (SCACP)

6.1	SCACP Description .....	6-1
6.1.1	Terminology Related to SCACP .....	6-1
6.1.1.1	SCS Ports and Circuits .....	6-1
6.1.1.2	Virtual Circuits .....	6-2
6.1.1.3	LAN Channels .....	6-2
6.1.1.4	IP Channels .....	6-3
6.1.1.5	Channels and Virtual Circuits .....	6-3
6.1.2	New Cluster SCA Circuit and Port Functionality .....	6-3
6.1.2.1	Ability to Set Port and Circuit Priorities .....	6-3
6.1.2.2	Ability to Enable/Disable PEdriver Checksumming .....	6-4
6.1.2.3	SCS Dynamic Load Class Support .....	6-4
6.1.3	Managing Cluster Ports and Circuits .....	6-4
6.1.4	Managing LAN/IP Cluster Ports .....	6-5
6.1.5	Troubleshooting Cluster Communications .....	6-5
6.1.6	Related Documents .....	6-5
6.2	SCACP Usage Summary .....	6-6
6.3	SCACP Commands .....	6-6
	CALCULATE .....	6-9
	EXIT .....	6-10
	HELP .....	6-11
	RELOAD .....	6-12
	SET CHANNEL .....	6-13
	SET CIRCUIT .....	6-15
	SET IP_INTERFACE .....	6-16
	SET LAN_DEVICE .....	6-17
	SET PORT .....	6-18
	SET TRACE .....	6-19
	SET VC .....	6-21
	SHOW CHANNEL .....	6-25
	SHOW CIRCUIT .....	6-31
	SHOW IP_INTERFACE .....	6-33
	SHOW LAN_DEVICE .....	6-36
	SHOW PORT .....	6-38
	SHOW TRACE .....	6-39
	SHOW VC .....	6-42
	SPAWN .....	6-44
	START IP_INTERFACE .....	6-45
	START LAN_DEVICE .....	6-46
	START TRACE .....	6-47
	STOP IP_INTERFACE .....	6-49
	STOP LAN_DEVICE .....	6-50
	STOP TRACE .....	6-51

## 7 Show Cluster Utility

7.1	SHOW CLUSTER Description	7-1
7.2	SHOW CLUSTER Usage Summary	7-11
7.3	SHOW CLUSTER Qualifiers	7-12
	/BEGINNING=time	7-13
	/CONTINUOUS	7-14
	/ENDING=time	7-15
	/INTERVAL=seconds	7-16
	/OUTPUT=file-spec	7-17
7.4	SHOW CLUSTER Commands	7-17
	@ (Execute Procedure)	7-20
	ADD CIRCUITS	7-21
	ADD CLUSTER	7-23
	ADD CONNECTIONS	7-25
	ADD COUNTERS	7-27
	ADD CREDITS	7-29
	ADD ERRORS	7-30
	ADD (Field)	7-31
	ADD LOCAL_PORTS	7-33
	ADD MEMBERS	7-35
	ADD SYSTEMS	7-36
	DEFINE/KEY	7-38
	DESELECT	7-41
	EXIT	7-42
	HELP	7-43
	INITIALIZE	7-44
	MOVE	7-45
	PAN	7-47
	REFRESH	7-49
	REMOVE CIRCUITS	7-50
	REMOVE CLUSTER	7-51
	REMOVE CONNECTIONS	7-52
	REMOVE COUNTERS	7-54
	REMOVE CREDITS	7-55
	REMOVE ERRORS	7-56
	REMOVE (Field)	7-57
	REMOVE LOCAL_PORTS	7-58
	REMOVE MEMBERS	7-59
	REMOVE SYSTEMS	7-60
	SAVE	7-62
	SCROLL	7-64
	SELECT	7-66
	SET AUTO_POSITIONING	7-67
	SET (Field)	7-68
	SET FUNCTION	7-69
	SET INTERVAL	7-70
	SET SCREEN	7-71

WRITE .....	7-72
-------------	------

## 8 System Generation Utility

8.1	SYSGEN Description .....	8-1
8.1.1	Specifying Values for SYSGEN Qualifiers and Parameters .....	8-1
8.1.2	Using Active and Current Parameter Values .....	8-1
8.2	SYSGEN Usage Summary .....	8-2
8.3	SYSGEN Commands .....	8-2
	CREATE .....	8-3
	DEINSTALL .....	8-4
	DISABLE .....	8-5
	ENABLE .....	8-6
	INSTALL .....	8-7
	SET .....	8-8
	SET/OUTPUT .....	8-9
	SET/STARTUP .....	8-10
	SHOW .....	8-11
	SHOW/STARTUP .....	8-16
	TERMINAL .....	8-17
	USE .....	8-18
	WRITE .....	8-20

## 9 System Management Utility

9.1	SYSMAN Description .....	9-1
9.1.1	Defining Keys to Execute SYSMAN Commands .....	9-2
9.1.2	Executing Commands from an Initialization File .....	9-2
9.2	SYSMAN Usage Summary .....	9-2
9.3	SYSMAN Commands .....	9-4
	@ (Execute Procedure) .....	9-8
	ALF ADD .....	9-10
	ALF REMOVE .....	9-12
	ALF SHOW .....	9-14
	ATTACH .....	9-15
	CLASS_SCHEDULE ADD .....	9-17
	CLASS_SCHEDULE DELETE .....	9-22
	CLASS_SCHEDULE MODIFY .....	9-23
	CLASS_SCHEDULE RESUME .....	9-25
	CLASS_SCHEDULE SHOW .....	9-26
	CLASS_SCHEDULE SUSPEND .....	9-27
	CONFIGURATION SET CLUSTER_AUTHORIZATION .....	9-28
	CONFIGURATION SET TIME .....	9-30
	CONFIGURATION SHOW CLUSTER_AUTHORIZATION .....	9-32
	CONFIGURATION SHOW TIME .....	9-33
	DEFINE/KEY .....	9-34
	DISKQUOTA ADD .....	9-36
	DISKQUOTA CREATE .....	9-38
	DISKQUOTA DELETE .....	9-40



DISKQUOTA DISABLE .....	9-41
DISKQUOTA ENABLE .....	9-43
DISKQUOTA MODIFY .....	9-45
DISKQUOTA REBUILD .....	9-47
DISKQUOTA REMOVE .....	9-48
DISKQUOTA SHOW .....	9-50
DO .....	9-51
DUMP_PRIORITY ADD (Alpha and Integrity servers) .....	9-55
DUMP_PRIORITY LIST (Alpha and Integrity servers) .....	9-58
DUMP_PRIORITY LOAD (Alpha and Integrity servers) .....	9-59
DUMP_PRIORITY MODIFY (Alpha and Integrity servers) .....	9-60
DUMP_PRIORITY REMOVE (Alpha Integrity servers) .....	9-63
DUMP_PRIORITY SHOW (Alpha and Integrity servers) .....	9-65
DUMP_PRIORITY UNLOAD (Alpha and Integrity servers) .....	9-66
EXIT .....	9-67
HELP .....	9-68
IO AUTOCONFIGURE (Alpha and Integrity servers) .....	9-69
IO CONNECT (Alpha and Integrity servers) .....	9-71
IO CREATE_WWID (Alpha and Integrity servers) .....	9-75
IO FIND_WWID (Alpha and Integrity servers) .....	9-76
IO LIST_WWID (Alpha and Integrity servers) .....	9-79
IO LOAD (Alpha and Integrity servers) .....	9-80
IO REBUILD (Alpha and Integrity servers) .....	9-81
IO REPLACE_WWID (Alpha and Integrity servers) .....	9-82
IO SCSI_PATH_VERIFY (Alpha and Integrity servers) .....	9-84
IO SET EXCLUDE (Alpha and Integrity servers) .....	9-85
IO SET PREFIX (Alpha and Integrity servers) .....	9-86
IO SHOW BUS (Alpha and Integrity servers) .....	9-87
IO SHOW DEVICE (Alpha and Integrity servers) .....	9-89
IO SHOW EXCLUDE (Alpha and Integrity servers) .....	9-91
IO SHOW PREFIX (Alpha and Integrity servers) .....	9-92
LICENSE LOAD .....	9-93
LICENSE UNLOAD .....	9-94
PARAMETERS DISABLE CHECKS .....	9-95
PARAMETERS ENABLE CHECKS .....	9-96
PARAMETERS SET .....	9-97
PARAMETERS SHOW .....	9-98
PARAMETERS USE .....	9-103
PARAMETERS WRITE .....	9-104
RESERVED_MEMORY ADD (Alpha and Integrity servers) .....	9-105
RESERVED_MEMORY EXTEND (Alpha and Integrity servers) .....	9-109
RESERVED_MEMORY FREE (Alpha and Integrity servers) .....	9-110
RESERVED_MEMORY LIST (Alpha and Integrity servers) .....	9-112
RESERVED_MEMORY MODIFY (Alpha and Integrity servers) .....	9-113
RESERVED_MEMORY REMOVE (Alpha and Integrity servers) .....	9-116
RESERVED_MEMORY SHOW (Alpha and Integrity servers) .....	9-117
SET ENVIRONMENT .....	9-119

SET PROFILE	9-121
SET TIMEOUT	9-122
SHOW ENVIRONMENT	9-123
SHOW KEY	9-124
SHOW PROFILE	9-125
SHOW TIMEOUT	9-126
SHUTDOWN NODE	9-127
SPAWN	9-131
STARTUP ADD	9-135
STARTUP DISABLE	9-137
STARTUP ENABLE	9-139
STARTUP MODIFY	9-140
STARTUP REMOVE	9-142
STARTUP SET DATABASE	9-143
STARTUP SET OPTIONS	9-144
STARTUP SHOW	9-146
SYS_LOADABLE ADD	9-148
SYS_LOADABLE REMOVE	9-150
9.4 RAD Example	9-151

## 10 USB Configuration Manager (UCM)

10.1 UCM Description	10-1
10.2 USB and UCM Concepts	10-1
10.2.1 Introduction to USB	10-2
10.2.2 UCM Concepts	10-4
10.2.3 The Discovery of Devices	10-5
10.3 Configuring Devices Automatically	10-7
10.4 Configuring Devices Manually	10-8
10.4.1 Disabling Automatic Configuration	10-9
10.4.2 Creating an Entry in the Permanent List	10-9
10.5 Viewing Configuration Events	10-10
10.5.1 Getting Information About Unknown Devices	10-11
10.5.2 Getting Information about Configuration Failures	10-11
10.6 UCM Usage Summary	10-12
10.7 UCM Commands	10-12
ADD DEVICE	10-14
DELETE DEVICE	10-16
EXIT	10-17
HELP	10-18
MODIFY DEVICE	10-19
RELOAD	10-21
RESTART	10-22
SET AUTO	10-23
SET LOG	10-25
SHOW AUTO	10-26
SHOW DEVICE	10-27
SHOW EVENTS	10-29

## 11 XA Gateway Control Program Utility (XGCP)

11.1	XGCP Description .....	11-1
11.2	XGCP Commands .....	11-1
11.3	XGCP Usage Summary .....	11-1
	CREATE_LOG .....	11-2
	EXIT .....	11-3
	START_SERVER .....	11-4
	STOP_SERVER .....	11-5

## A Supplemental MONITOR Information—Record Formats

A.1	The MONITOR Recording File .....	A-1
A.2	Conventions .....	A-3
A.3	HP Control Records .....	A-3
A.3.1	File Header Record .....	A-4
A.3.2	System Information Record .....	A-6
A.3.3	Node Transition Record .....	A-7
A.3.4	RMS File Record .....	A-7
A.4	Class Records .....	A-8
A.4.1	Class Type Formats .....	A-8
A.4.1.1	Class Header .....	A-9
A.4.1.2	Class Prefix (Component Classes Only) .....	A-10
A.4.2	Class Data Blocks .....	A-11
A.4.2.1	CLUSTER Class Record .....	A-11
A.4.2.2	DECNET Class Record .....	A-13
A.4.2.3	DISK Class Record .....	A-14
A.4.2.4	DLOCK Class Record .....	A-15
A.4.2.5	FCP Class Record .....	A-17
A.4.2.6	FILE_SYSTEM_CACHE Class Record .....	A-19
A.4.2.7	I/O Class Record .....	A-20
A.4.2.8	LOCK Class Record .....	A-22
A.4.2.9	MODES Class Record .....	A-23
A.4.2.10	MSCP_SERVER Class Record .....	A-25
A.4.2.11	PAGE Class Record .....	A-26
A.4.2.12	PROCESSES Class Record .....	A-28
A.4.2.13	RLOCK Class Record .....	A-30
A.4.2.14	RMS Class Record .....	A-31
A.4.2.15	SCS Class Record .....	A-32
A.4.2.16	STATES Class Record .....	A-34
A.4.2.17	SYSTEM Class Record .....	A-36
A.4.2.18	TIMER Class Record .....	A-37
A.4.2.19	TRANSACTION Class Record .....	A-38

## B HP OpenVMS Integrity servers Serial Multiplexer (MUX) Support for Integrity Servers

B.1	Conforming Devices .....	B-1
B.2	Device Installation .....	B-4

## C SHOW CLUSTER Keypad Commands

C.1	Using the Keypad . . . . .	C-1
C.2	Redefining the Keypad Keys . . . . .	C-3
C.3	Redefining the Arrow Keys . . . . .	C-3

## D System Parameters

D.1	How the Parameters are Described . . . . .	D-1
D.1.1	Parameter Categories and Attributes . . . . .	D-1
D.1.2	Values for Parameters . . . . .	D-2
D.2	Parameter Descriptions . . . . .	D-2
D.2.1	System Parameters . . . . .	D-3

## Index

## Figures

6-1	Sample SHOW CHANNEL/ALL output . . . . .	6-27
6-2	Sample SHOW CHANNEL/ECS output . . . . .	6-29
6-3	Sample SHOW CHANNEL/IP output . . . . .	6-30
6-4	Sample SHOW CHANNEL/LANCHANNEL output . . . . .	6-30
6-5	Sample SHOW IP_INTERFACE/ALL output . . . . .	6-34
6-6	Sample SHOW LAN/ALL output . . . . .	6-37
7-1	Sample SHOW CLUSTER Report . . . . .	7-10
10-1	USB Configuration . . . . .	10-3
10-2	Hub Tiers . . . . .	10-4
10-3	UCM Architecture . . . . .	10-5
A-1	File Header Record Format - Alpha and Integrity servers . . . . .	A-4
A-2	System Information Record Format - Alpha and Integrity servers . . . . .	A-6
A-3	Node Transition Record Format . . . . .	A-7
A-4	RMS File Record Format . . . . .	A-8
A-5	Class Record Format . . . . .	A-9
A-6	Class Header Format - Alpha and Integrity servers . . . . .	A-9
A-7	Class Prefix Format . . . . .	A-11
A-8	CLUSTER Class Record Format . . . . .	A-12
A-9	DECNET Class Record Format . . . . .	A-13
A-10	DISK Class Record Format - Alpha and Integrity servers . . . . .	A-14
A-11	DLOCK Class Record Format . . . . .	A-16
A-12	FCP Class Record Format . . . . .	A-18
A-13	FILE_SYSTEM_CACHE Class Record Format . . . . .	A-19
A-14	I/O Class Record Format . . . . .	A-21
A-15	LOCK Class Record Format . . . . .	A-22
A-16	MODES Class Record Format . . . . .	A-24
A-17	MSCP_SERVER Class Record Format . . . . .	A-25
A-18	PAGE Class Record Format . . . . .	A-27
A-19	PROCESSES Class Record Format - Alpha and Integrity servers . . . . .	A-29
A-20	RLOCK Class Record Format . . . . .	A-31
A-21	RMS Class Record Format . . . . .	A-32

A-22	SCS Class Record Format . . . . .	A-33
A-23	STATES Class Record Format . . . . .	A-35
A-24	SYSTEM Class Record Format . . . . .	A-36
A-25	TIMER Class Record Format . . . . .	A-37
A-26	TRANSACTION Class Record Format . . . . .	A-38
C-1	SHOW CLUSTER Default Keypad . . . . .	C-1

## Tables

1	Manual Structure . . . . .	xv
3-1	PPPD Command Summary . . . . .	3-2
6-1	SCACP Commands . . . . .	6-7
6-2	Channel Error Data . . . . .	6-28
6-3	IP or LAN Device Error Data . . . . .	6-34
7-1	Classes of SHOW CLUSTER Information . . . . .	7-1
7-2	CIRCUITS Class Fields . . . . .	7-2
7-3	CLUSTER Class Fields . . . . .	7-3
7-4	CONNECTIONS Class Fields . . . . .	7-4
7-5	COUNTERS Class Fields . . . . .	7-5
7-6	CREDITS Class Fields . . . . .	7-5
7-7	ERRORS Class Fields . . . . .	7-5
7-8	LOCAL_PORTS Class Fields . . . . .	7-6
7-9	MEMBERS Class Fields . . . . .	7-7
7-10	SYSTEMS Class Fields . . . . .	7-9
9-1	SYSMAN Commands . . . . .	9-4
9-2	/SELECT Qualifier Examples . . . . .	9-69



---

# Preface

The *HP OpenVMS System Management Utilities Reference Manual: M–Z* contains reference information about the utilities that are used to manage the OpenVMS Alpha and Integrity servers system management utility and provides examples for frequently used commands and qualifiers. The utilities appear alphabetically.

See the *HP OpenVMS System Management Utilities Reference Manual: A–L* for the utilities not discussed in this book. In addition to system management utilities, a description and usage summary of the AUTOGEN command procedure is presented in the *HP OpenVMS System Management Utilities Reference Manual: A–L*.

All commands follow standard rules of grammar as specified in the *HP OpenVMS DCL Dictionary*.

For information using these system management utilities and AUTOGEN, see the *HP OpenVMS System Manager’s Manual*.

## Intended Audience

This manual is intended for system managers and users of the system management utilities for the OpenVMS Alpha and Integrity server operating systems.

## Document Structure

The parts of this manual are arranged alphabetically. Each part contains reference information for a system management utility. Table 1 shows the structure.

**Table 1 Manual Structure**

Part	Utility
1	Monitor (MONITOR)
2	MSA Utility (MSAUTIL)
3	Point-to-Point Protocol Utility (PPPD)
4	POLYCENTER Software Installation utility (PRODUCT)
5	HP 8 Internal Port Serial Attached SCSI Host Bus Adapter (SAS Controller)
6	SCA Control Program utility (SCACP)
7	Show Cluster (SHOW CLUSTER)
8	System Generation (SYSGEN)

(continued on next page)

**Table 1 (Cont.) Manual Structure**

Part	Utility
9	System Management (SYSMAN)
10	USB Configuration Manager (UCM)
11	XA Gateway Control Program utility (XGCP)

## Related Documents

For more information about the OpenVMS system management utilities, see the following documents:

- *HP OpenVMS System Management Utilities Reference Manual: A–L*
- *HP OpenVMS System Services Reference Manual*
- *HP OpenVMS System Manager’s Manual*
- *HP OpenVMS DCL Dictionary*
- *HP OpenVMS Guide to System Security*
- *HP POLYCENTER Software Installation Utility Developer’s Guide*
- *HP OpenVMS License Management Utility Manual*
- *OpenVMS User’s Manual*
- *OpenVMS VAX Device Support Manual (Archived)*
- *HP OpenVMS Programming Concepts Manual*
- *OpenVMS Programming Interfaces: Calling a System Routine*
- *OpenVMS Record Management Services Reference Manual*
- *HP Volume Shadowing for OpenVMS*
- *HP OpenVMS Cluster Systems*
- *Writing OpenVMS Alpha Device Drivers in C* (Margie Sherlock and Leonard Szubowicz, Digital Press, 1996)

For additional information about HP OpenVMS products and services, see:

<http://www.hp.com/go/openvms>

## Reader’s Comments

HP welcomes your comments on this manual. Please send your comments or suggestions to:

[openvmsdoc@hp.com](mailto:openvmsdoc@hp.com)

## How To Order Additional Documentation

For information about how to order additional documentation, see:

<http://www.hp.com/go/openvms/doc/order>



## Conventions

VMScluster systems are now referred to as OpenVMS Cluster systems. Unless otherwise specified, references to OpenVMS Cluster systems or clusters in this document are synonymous with VMScluster systems.

The contents of the display examples for some utility commands described in this manual may differ slightly from the actual output provided by these commands on your system. However, when the behavior of a command differs significantly between OpenVMS Alpha and Integrity servers, that behavior is described in text and rendered, as appropriate, in separate examples.

In this manual, every use of DECwindows and DECwindows Motif refers to DECwindows Motif for OpenVMS software.

The following conventions are also used in this manual:

Ctrl/ <i>x</i>	A sequence such as Ctrl/ <i>x</i> indicates that you must hold down the key labeled Ctrl while you press another key or a pointing device button.
PF1 <i>x</i>	A sequence such as PF1 <i>x</i> indicates that you must first press and release the key labeled PF1 and then press and release another key or a pointing device button.
<span style="border: 1px solid black; padding: 2px;">Return</span>	In examples, a key name enclosed in a box indicates that you press a key on the keyboard. (In text, a key name is not enclosed in a box.)  In the HTML version of this document, this convention appears as brackets, rather than a box.
...	A horizontal ellipsis in examples indicates one of the following possibilities: <ul style="list-style-type: none"><li>• Additional optional arguments in a statement have been omitted.</li><li>• The preceding item or items can be repeated one or more times.</li><li>• Additional parameters, values, or other information can be entered.</li></ul>
.	A vertical ellipsis indicates the omission of items from a code example or command format; the items are omitted because they are not important to the topic being discussed.
( )	In command format descriptions, parentheses indicate that you must enclose the options in parentheses if you choose more than one.
[ ]	In command format descriptions, brackets indicate optional choices. You can choose one or more items or no items. Do not type the brackets on the command line. However, you must include the brackets in the syntax for OpenVMS directory specifications and for a substring specification in an assignment statement.
[   ]	In command format descriptions, vertical bars separate choices within brackets or braces. Within brackets, the choices are options; within braces, at least one choice is required. Do not type the vertical bars on the command line.

{ }	In command format descriptions, braces indicate required choices; you must choose at least one of the items listed. Do not type the braces on the command line.
<b>bold text</b>	This text style represents the introduction of a new term or the name of an argument, an attribute, or a reason.
<i>italic text</i>	Italic text indicates important information, complete titles of manuals, or variables. Variables include information that varies in system output (Internal error <i>number</i> ), in command lines (/PRODUCER= <i>name</i> ), and in command parameters in text (where <i>dd</i> represents the predefined code for the device type).
UPPERCASE TEXT	Uppercase text indicates a command, the name of a routine, the name of a file, or the abbreviation for a system privilege.
Monospace type	Monospace type indicates code examples and interactive screen displays.  In the C programming language, monospace type identifies the following elements: keywords, the names of independently compiled external functions and files, syntax summaries, and references to variables or identifiers introduced in an example.
-	A hyphen at the end of a command format description, command line, or code line indicates that the command or statement continues on the following line.
numbers	All numbers in text are assumed to be decimal unless otherwise noted. Nondecimal radices—binary, octal, or hexadecimal—are explicitly indicated.

---

## Monitor Utility

### 1.1 MONITOR Description

The Monitor utility (MONITOR) is a system management tool used to obtain information about operating system performance. MONITOR allows you to monitor classes of systemwide performance data (such as system I/O statistics, page management statistics, and time spent in each of the processor modes) at specifiable intervals, and produce several types of output.

To monitor a particular class of information, specify the class names corresponding to the information classes that you want to monitor. For example, to monitor page management statistics, specify the PAGE class name in the MONITOR command. MONITOR collects system performance data by class and produces the following three forms of optional output:

- A disk recording file in binary format
- Statistical terminal displays
- A disk file containing statistical summary information in ASCII format

The utility initiates a single MONITOR request for the classes of performance data specified each time you enter a command in the following form:

```
MONITOR [/qualifier[,...]] classname[,...] [/qualifier[,...]]
```

Regardless of the order in which you specify classname parameters, MONITOR always executes requests in the following sequence:

```
PROCESSES  
STATES  
MODES  
PAGE  
IO  
FCP  
LOCK  
DECNET  
FILE_SYSTEM_CACHE  
DISK  
DLOCK  
SCS  
SYSTEM  
CLUSTER  
RMS  
MSCP_SERVER  
TRANSACTION  
VECTOR  
TIMER  
RLOCK
```

## **MONITOR**

### **1.1 MONITOR Description**

Depending on the command qualifiers specified, MONITOR collects system performance data from the running system or plays back data recorded previously in a recording file. When you play back data, you can display it, summarize it, and even rerecord it to reduce the amount of data in the recording file.

## 1.2 MONITOR Usage Summary

The Monitor utility (MONITOR) is a system management tool that enables you to obtain information about operating system performance.

### Format

MONITOR

#### Parameters

None.

### Description

Issuing the MONITOR command from the DCL prompt invokes the Monitor utility and allows you to use any of the Monitor utility commands as follows:

```
$ MONITOR  
MONITOR>
```

To begin monitoring a system, issue the Monitor utility MONITOR command.

---

**Note**

---

If you attempt to monitor a remote node that is incompatible, the system displays the following message:

```
%MONITOR-E-SRVMISMATCH, MONITOR server on remote node is an incompatible  
version
```

If you receive this message, contact your HP support representative for a remedial kit that corrects this problem.

Before you install the remedial kit, you can still use MONITOR to obtain data about the remote node. To do this, record the data on the remote node, and then run the MONITOR playback feature to examine the data on the local node.

---

Generally, each MONITOR request runs until the time specified or implied by the /ENDING qualifier. To exit from MONITOR, enter the EXIT command at the MONITOR> prompt or press Ctrl/Z. To terminate a MONITOR request without exiting from the utility, press Ctrl/C.

Information that MONITOR collect is usually displayed as ASCII screen images. You can use the optional /DISPLAY qualifier to specify a disk file to contain the information. If you omit the file specification, output is directed to SYS\$OUTPUT. See the Monitor utility MONITOR command for a discussion of the /DISPLAY qualifier.

You can also initiate MONITOR requests from command level by entering the DCL command MONITOR with the desired qualifiers and parameters. However, in terms of conserving system resources, it is preferable to initiate requests in response to the MONITOR> prompt.

# MONITOR

## 1.3 MONITOR Commands

### 1.3 MONITOR Commands

This section describes and provides examples of MONITOR commands. For commands that specify classname parameters (other than ALL\_CLASSES), a sample display or summary of each class is provided, with a brief description of the items in the class.

MONITOR recognizes the exclamation point (!) as a comment character. Thus, full- or partial-line comments are acceptable in command files specified as input to MONITOR.

Note that in MONITOR, **rate** indicates the number of occurrences per second. For example, the Page Fault rate indicates the number of page faults per second.

The following table lists the commands described in this section:

Command	Description
ALIGN	On Integrity server systems, displays information about alignment faults.
CONVERT	Converts a pre-Version 5.0 MONITOR recording file to the current format.
EXECUTE (@)	Executes a series of MONITOR commands contained in a file.
EXIT	Terminates MONITOR, returning control to command level.
HELP	Displays information about MONITOR.
INITIALIZE	Reestablishes initial default settings for parameters and qualifiers altered by the SET DEFAULT command.
MONITOR	Initiates monitoring of statistics for the classes of information you specify.
SET DEFAULT	Sets command qualifier, classname parameter, and classname qualifier defaults for the MONITOR command.
SHOW DEFAULT	Displays the defaults established by the SET DEFAULT command.

## ALIGN (Integrity servers only)

On Integrity server systems, the ALIGN command displays information about alignment faults, thereby helping troubleshoot HP Integrity server systems.

### Format

ALIGN

### Description

The MONITOR ALIGN class displays a rate of alignment faults for each mode (kernel, executive, supervisor and user), along with the total alignment faults per second. If the alignment fault rate is very high, HP recommends that you use the Alignment Fault Utility (FLT) to analyze the cause of the alignment faults.

On Integrity server systems, the operating system handles all alignment faults. Therefore, you can increment counters to track the alignment fault rate. On Alpha systems, PALcode in the console corrects alignment faults. Therefore, you cannot tick counters without incurring much overhead. For this reason, the MONITOR command ALIGN is available only on Integrity servers.

### Example

MONITOR> ALIGN

```

                                ALIGNMENT FAULT STATISTICS
                                on node MTDIB9
                                11-JAN-2006 16:58:07.25

```

	CUR	AVE	MIN	MAX
Kernel Fault Rate	19529.00	19529.00	19529.00	19529.00
Exec Fault Rate	7581.00	7581.00	7581.00	7581.00
Super Fault Rate	0.00	0.00	0.00	0.00
User Fault Rate	164972.00	164972.00	164972.00	164972.00
Total Fault Rate	192082.00	192082.00	192082.00	192082.00

This example shows the alignment fault rate on the current system.

# MONITOR CONVERT

---

## CONVERT

The CONVERT command converts a pre-Version 5.0 MONITOR recording file to the current format.

### Format

CONVERT file-spec

### Parameter

#### **file-spec**

Specifies the file to be converted. The default file specification is MONITOR.DAT.

### Qualifier

#### **/OUTPUT**

The file specification of the converted file. The default specification is MONITOR.DAT.

### Description

You must convert pre-Version 5.0 recording files to the current format before attempting to play them back with the current MONITOR version.

### Example

```
MONITOR> CONVERT 24MAY_MONITOR.DAT/OUTPUT=24MAY_NEWMON.DAT
```

This command converts the file 24MAY\_MONITOR.DAT to the current format and names the output file 24MAY\_NEWMON.DAT.



---

## **EXECUTE (@)**

The EXECUTE command or the at sign (@) executes a series of MONITOR commands contained in a file.

### **Format**

EXECUTE (@) file-spec

### **Parameter**

**file-spec**

Specifies a command file to be executed by the EXECUTE (@) command.

### **Qualifiers**

None.

### **Description**

With the EXECUTE command, you can direct MONITOR to obtain command input from a specified file rather than from the terminal. The file can contain any valid MONITOR command except an EXECUTE (@) command. Commands in the file are executed sequentially. If you omit the optional file specification, the default is MONITOR.MON.

After the file has executed, subsequent commands are obtained from the terminal.

### **Example**

```
MONITOR> EXECUTE INQMEM.MON
```

```
.  
.
```

```
MONITOR> MONITOR /RECORD
```

Contents of the file INQMEM.MON are as follows:

```
! This file sets defaults for a memory management inquiry using  
! INTERVAL=5, PAGE, IO, and PROCESSES/TOPFAULT  
!
```

```
.  
.
```

```
SET DEFAULT /INTERVAL=5 PAGE, IO, PROCESSES/TOPFAULT
```

In this example, appropriate default values for a memory management investigation are established in the file INQMEM.MON, and the file is executed with the EXECUTE command. Then a subsequent MONITOR command uses those defaults, adding the /RECORD qualifier, to display and record the selected classes with a 5-second interval.

Note that the defaults established when the file INQMEM.MON is executed remain in effect until changed explicitly or until you exit from the utility.

## **MONITOR EXIT**

---

### **EXIT**

The EXIT command terminates MONITOR, returning control to command level.

### **Format**

EXIT

### **Parameters**

None.

### **Qualifiers**

None.

## **HELP**

The HELP command displays information about MONITOR.

### **Format**

HELP [command]

### **Parameter**

**command**

Specifies the name of a MONITOR command for which HELP is desired.

### **Qualifiers**

None.

### **Example**

```
MONITOR> HELP MONITOR INITIALIZE
```

The INITIALIZE command reestablishes initial default settings for parameters and qualifiers previously altered by the SET DEFAULT command.

The command in this example requests help information about the INITIALIZE command.

# MONITOR INITIALIZE

---

## INITIALIZE

The INITIALIZE command reestablishes initial default settings for parameters and qualifiers altered by the SET DEFAULT command.

### Format

INITIALIZE

### Parameters

None.

### Qualifiers

None.

---

## MONITOR

The MONITOR command initiates monitoring of statistics for the classes of information you specify.

### Format

MONITOR [/command qualifier[,...]] classname[,...] [/classname qualifier[,...]]

### Parameter

#### **classname[,...]**

Specifies the class of performance data to be monitored. To monitor all classes, specify the ALL\_CLASSES parameter. When you specify several classes, separate the classname parameters with commas or plus signs. You cannot specify the CLUSTER class name with any other class name. Cluster monitoring functions require that DECnet for OpenVMS be installed.

You must specify one or more of the following parameters:

Parameter	Description
ALL_CLASSES	Statistics for all classes
CLUSTER	Clusterwide performance statistics
DECNET	DECnet for OpenVMS statistics
DISK	Disk I/O statistics
DLOCK	Distributed lock management statistics
FCP	File control primitive statistics
FILE_SYSTEM_CACHE	File system cache statistics
IO	System I/O statistics
LOCK	Lock management statistics
MODES	Time spent in each of the processor modes
MSCP_SERVER	MSCP server statistics
PAGE	Page management statistics
PROCESSES	Statistics on all processes
RLOCK	Dynamic lock remastering statistics
RMS	Record Management Services statistics
SCS	System Communications Services statistics
STATES	Number of processes in each of the scheduler states
SYSTEM	Summary of statistics from other classes
TIMER	Timer Queue Entry (TQE) statistics
TRANSACTION	DECdtm services statistics
VECTOR	Vector processor scheduled usage

This section describes qualifiers for the MONITOR and SET DEFAULT commands. Note that these commands accept the same qualifiers. As these qualifiers follow the standard rules of DCL grammar as specified in the *HP OpenVMS DCL Dictionary*, you can abbreviate any qualifier or keyword as long as the abbreviation is not ambiguous. Use the asterisk (\*) and the percent sign (%) as wildcard characters unless otherwise noted.

# MONITOR MONITOR

## Command Qualifier Descriptions

### **/BEGINNING=time**

Specifies the time that monitoring begins, by using a combination of absolute and delta times. Observe the syntax rules for time values described in the online help topic DCL\_Tips (subtopic Date\_Time).

If you are monitoring a running system, and you omit the /BEGINNING qualifier, monitoring begins when you enter the MONITOR command. However, if you have specified the /INPUT qualifier to play back data from an input recording file, /BEGINNING defaults to the beginning time recorded in the input file. If you specify /BEGINNING with a time but are playing back a recording file, MONITOR selects either the beginning time of the file or the beginning time you specify, whichever is later. If you are monitoring a remote node, the local node time is used to determine beginning time.

If you specify a future time for a request to monitor a running system, MONITOR issues an informational message, and the process issuing the request hibernates until the specified time. This feature can be useful when you run MONITOR from a batch job.

### **/BY\_NODE**

### **/NOBY\_NODE**

Specifies that performance class data in a multifile summary be displayed as a single column of AVERAGE statistics for each node.

The /BY\_NODE qualifier displays data in a multifile summary. If you specify only one input file, MONITOR ignores the /BY\_NODE qualifier because you are not performing a multifile summary.

You can specify the /BY\_NODE qualifier only in combination with the /SUMMARY qualifier. One column of AVERAGE statistics per node appears for each class requested.

By default, multifile summaries include one column of AVERAGE statistics for each node requested in each input file.

### **/COMMENT=string**

### **/NOCOMMENT (default)**

Specifies an ASCII string to be stored in the output recording file. The string can contain up to 60 characters.

The /COMMENT qualifier is valid only when /RECORD is also specified. (MONITOR ignores the /COMMENT qualifier if you do not use the /RECORD qualifier in the command line.) If you omit the qualifier or specify /NOCOMMENT, a string consisting of 60 blanks is stored in the recording file by default.

When a recording file containing a comment is played back, the comment is included in the heading of the display or single-file summary. Note that comment text is not displayed on playback for the CLUSTER class unless either the /SUMMARY or the /ALL qualifier is also used.

### **/DISPLAY[=file-spec] (default)**

### **/NODISPLAY**

Specifies whether information collected by MONITOR is to be displayed as ASCII screen images. Optionally names the disk file to contain the output.

If you omit the optional file specification, output is written to SYS\$OUTPUT.

Note that although display output is produced by default, display output is never produced when a multifile summary is requested.

**/ENDING=time**

Specifies the time that monitoring ends, by using a combination of absolute and delta times. Observe the syntax rules for time values described in the online help topic DCL\_Tips (subtopic Date\_Time).

If you are monitoring a running system and omit the /ENDING qualifier, monitoring continues until you terminate the request with Ctrl/C or Ctrl/Z. If you have also specified the /INPUT qualifier to play back data from an input recording file, /ENDING defaults to the ending time recorded in the input file. If you specify /ENDING with a time, but are playing back a recording file, MONITOR selects the earlier of the ending time of the file and the ending time you specify. For live requests, the local node's time-stamp is used to determine ending time.

You can prematurely terminate a request, regardless of the value of the /ENDING qualifier, by pressing Ctrl/C or Ctrl/Z. To prematurely terminate a request running in a noninteractive process (that is, a batch job or a detached process or subprocess), enter the appropriate DCL command to terminate the process.

**/FLUSH\_INTERVAL=seconds**

Specifies the interval, in seconds, at which data collected by MONITOR (contents of MONITOR buffers) is written to disk. Values must be in the range from 1 to 9,999. The default interval is 300 seconds.

If you are writing data to a shared recording file currently in use, specify a short interval to ensure that others accessing the file receive data that is as current as possible. The smaller the interval, the less data is lost if a system failure occurs while recording.

**/INPUT[(file-spec,...)]****/NOINPUT (default)**

Controls whether performance data is played back from one or more input files or collected from the running system. If you specify more than one file, enclose the list in parentheses, and separate the file specifications with commas. Wildcard characters are allowed in the file specification.

---

**Caution**

---

Data in all files in the list must have been collected by the same OpenVMS version.

---

With multiple input files, you must use the /SUMMARY qualifier. The maximum number of files MONITOR accepts for a multifile summary is 5000. In a multifile summary request, the classes CLUSTER and PROCESSES are ignored. If these classes are the only classes specified on the command line, MONITOR does not recognize them and displays a "no classes specified" error message.

In a list of input files, any omitted segment of the file specification (name or type) is defaulted to the corresponding segment of the previous file specification.

If you omit the file type, and you have not specified the file type previously in an input file list, the default file type .DAT is used. If you omit the file specification, MONITOR assigns the default file name MONITOR.DAT. The current device and directory defaults are applied.

# MONITOR MONITOR

If you omit the qualifier, performance data is collected from the running system.

## **/INTERVAL=seconds**

Specifies the sampling interval between data collection events, recording events, and display events. Values can range from 1 to 9,999,999.

Collection events, recording events, and display events occur within a MONITOR request. Use the /INTERVAL qualifier to control the frequency of these events. A collection event causes raw data for all requested classes to be collected from the operating system or from a previously recorded file. A recording event causes data for all requested classes to be written to a recording file. A display event causes a screen image to be composed, for a single class, from the accumulated data collected for that class since the beginning of the MONITOR request.

For live collection requests, a collection event is always followed immediately by a recording event (if requested). The frequency of collection/recording event pairs is controlled by the /INTERVAL qualifier, which specifies the number of seconds that must elapse between occurrences of the event pair. Display events occur asynchronously to collection/recording event pairs at a frequency governed by the /VIEWING\_TIME qualifier.

For playback requests, a collection event occurs each time a new interval is encountered in the input file of previously recorded data. A recording event (if requested) does not necessarily follow immediately as it does in live collection. Its frequency is still governed by the /INTERVAL qualifier; the specified /INTERVAL value is interpreted in terms of the /INTERVAL value specified when the input file was created. The new value must be an integral multiple of the original value. A recording event is then triggered every time an interval is encountered in the input file that is the appropriate multiple of the original interval.

For playback requests, occurrences of display events (if requested) are indicated in exactly the same way as recording events (with the /INTERVAL qualifier) and immediately follow recording events (if both are specified). The actual length of time a displayed image remains on the screen is still specified with the /VIEWING\_TIME qualifier, but, unlike the live collection case, this qualifier is not used to signal a display event.

The following table summarizes which qualifiers cause the various MONITOR events:

<b>Event</b>	<b>Live Collection Qualifier</b>	<b>Playback Qualifier</b>
Collection	/INTERVAL	Original /INTERVAL value (from file)
Recording	/INTERVAL	/INTERVAL
Display	/VIEWING_TIME	/INTERVAL

Note that, for live requests, the collection interval is defined as the number of seconds from the end of one collection event to the beginning of the next. A collection event includes collection for all requested classes on all nodes specified. (For multiple-node requests, a collection event must complete on all nodes before a new event is initiated.) Therefore, the elapsed time from the beginning of one collection event to the beginning of the next is the interval value plus the time it takes to do the collection. For some requests, notably those including many classes or the PROCESSES, RMS, CLUSTER, or SYSTEM classes, collection time can be significant.



For /INPUT requests, the interval value defaults to the value specified in the input recording file. The default for monitoring the running system is 3 seconds for all classes except ALL\_CLASSES, CLUSTER, and SYSTEM, which have a default of 6 seconds.

**/NODE=(nodename,...)**

Specifies the nodes (up to 48 in a cluster) for which data is to be collected. If you specify more than one name, separate the names with commas, and enclose the list in parentheses.

Remote monitoring in an OpenVMS Cluster environment might not be compatible for nodes that are running different OpenVMS versions. The following table shows the compatibility of versions for remote monitoring:

	<b>OpenVMS Alpha and VAX Version 6.0 and later</b>	<b>OpenVMS Alpha Version 1.5 and VAX Version 5.n</b>
OpenVMS Alpha and VAX Version 6.0 or later	Yes	No
OpenVMS Alpha Version 1.5 and VAX Version 5.n	No	Yes

To obtain data from an incompatible remote node, record the data on the remote node and then use the MONITOR playback feature to examine the data on the local node. The *HP OpenVMS System Manager's Manual* describes remote monitoring. If you specify multiple node names with multiple system classes, MONITOR displays one class at a time for each node. For example, the command MONITOR/NODE=(NODE\_A,NODE\_B) STATES,MODES generates STATES data for NODE\_A and NODE\_B and then MODES data.

**/OUTPUT=file-spec**

Used with the CONVERT command, this qualifier specifies the name of the converted recording file. The default specification is MONITOR.DAT. File lists are not permitted.

Recording files produced using MONITOR prior to VMS Version 5.0 must be converted to the current format before they can be played back by the current MONITOR version.

**/RECORD[=file-spec]**

**/NORECORD (default)**

Specifies that a binary disk file be created containing all collected data for the request. Note that recording is restricted to files on disks. No wildcard characters are allowed in the file specification. If you omit the file type, the default file type is .DAT. If you omit the file specification, output is generated to a file named MONITOR.DAT in the current default device and directory. If you specify an existing file but omit the version number, a new version of the file is created.

The output consists of all data for the requested classes, regardless of the classname qualifiers specified. Note that recording file output is not produced when a multifile summary is requested.

**/SUMMARY[=file-spec]**

**/NOSUMMARY (default)**

Specifies that an ASCII disk file be created containing summary statistics on all data collected for this request. If the optional file specification is omitted, it defaults to MONITOR.SUM.

## MONITOR MONITOR

The summary file, generated at the end of monitoring, contains one or more pages of output for each requested class. The format of each page is similar to that of display output and is determined by the classname qualifiers. The /ALL qualifier is applied to all class names for which no other qualifier is specified.

### **/VIEWING\_TIME=seconds**

Specifies the duration for each screen image display for /DISPLAY requests. Values can range from 1 to 9,999,999.

If you are monitoring the running system, /VIEWING\_TIME defaults to the /INTERVAL value. If you specify /INPUT, and you are monitoring a recording file, /VIEWING\_TIME defaults to 3 seconds.

Effective viewing time varies, however, depending on whether you are running MONITOR on your local system or on a remote node. (*Remote* in this context refers to the use of the SET HOST command to access another node.) For remote access, the time required to display the screen is included in the viewing time, while for local access, this time is not included. Therefore, use a larger viewing time than the 3-second default when running MONITOR on a remote system. The value appropriate for remote access depends on your terminal baud rate. For a 9600-baud terminal line, 6 seconds is a reasonable viewing time.

Note also that the time between full screens of data for the PROCESSES display is controlled by this qualifier.

---

## MONITOR ALL\_CLASSES

The MONITOR ALL\_CLASSES command initiates monitoring of statistics for all classes except the CLUSTER and RMS classes.

### Format

MONITOR ALL\_CLASSES

### Command Qualifiers

**/qualifier[,...]**

One or more qualifiers as described in the Command Qualifier Descriptions section.

### Classname Qualifiers

**/ALL**

Specifies that a table of all available statistics (current, average, minimum, and maximum) is to be included in the display and summary output. For summary output, this qualifier is the default for all classes; otherwise, it is the default for all classes except CLUSTER, MODES, PROCESSES, STATES, SYSTEM, and VECTOR.

**/AVERAGE**

Specifies that a bar graph of average statistics is to be included in the display and summary outputs.

**/CURRENT**

Specifies that a bar graph of current statistics is to be included in the display and summary outputs. The /CURRENT qualifier is the default for the CLUSTER, MODES, STATES, SYSTEM, and VECTOR classes.

**/MAXIMUM**

Specifies that a bar graph of maximum statistics is to be included in the display and summary outputs.

**/MINIMUM**

Specifies that a bar graph of minimum statistics is to be included in the display and summary outputs.

### Description

If you do not specify any qualifiers with the ALL\_CLASSES parameter, normal default output is produced for each class. The qualifiers have no effect on display of the PROCESSES class.

Note that the default interval is 6 seconds.

The MONITOR ALL\_CLASSES command is particularly useful for playback of recording files because it eliminates the need to specify the particular classes of performance data the recording file contains. To override any of the default qualifiers, specify the class name with the qualifier after specifying ALL\_CLASSES.

## MONITOR MONITOR ALL\_CLASSES

### Example

```
MONITOR> MONITOR/INPUT=SYS$MANAGER:LOADBAL.DAT ALL_CLASSES,PROCESSES/TOPCPU
```

This command initiates playback of the recording file  
SYS\$MANAGER:LOADBAL.DAT. All data contained in the file will be displayed.

---

## MONITOR CLUSTER

The MONITOR CLUSTER command initiates monitoring of the CLUSTER statistics class, which shows clusterwide CPU, memory, disk, and locking activity.

### Format

MONITOR CLUSTER

### Command Qualifiers

**/qualifier[,...]**

One or more qualifiers as described in the Command Qualifier Descriptions section.

### Classname Qualifiers

**/ALL**

Specifies that a table of all available statistics (current, average, minimum, and maximum) is to be included in the display and summary output. For summary output, this qualifier is the default for all classes; otherwise, it is the default for all classes except CLUSTER, MODES, PROCESSES, STATES, SYSTEM, and VECTOR.

**/AVERAGE**

Specifies that a bar graph of average statistics is to be included in the display and summary outputs.

**/CURRENT**

Specifies that a bar graph of current statistics is to be included in the display and summary outputs. The /CURRENT qualifier is the default for the CLUSTER, MODES, STATES, SYSTEM, and VECTOR classes.

**/MAXIMUM**

Specifies that a bar graph of maximum statistics is to be included in the display and summary outputs.

**/MINIMUM**

Specifies that a bar graph of minimum statistics is to be included in the display and summary outputs.

### Description

MONITOR is capable of using both TCP/IP and DECnet as a transport mechanism. For more information about MONITOR Cluster for TCP/IP, see Section 6.7.10 of the *HP OpenVMS System Manager's Manual, Volume 2: Tuning, Monitoring, and Complex Systems*.

For the CLUSTER class, MONITOR collects data items for up to 48 nodes in a cluster. Because this class combines the most significant clusterwide performance statistics in a single display, it is particularly useful to cluster managers and other users seeking an overview of cluster activity.

MONITOR does not recognize nodes that enter the cluster while a request is active. MONITOR, therefore, does not collect data for these nodes.

You cannot specify the CLUSTER class in the same request with any other class.

## MONITOR MONITOR CLUSTER

In a multiframe summary request, the classes CLUSTER and PROCESSES are ignored. If these classes are the only classes specified on the command line, MONITOR does not recognize them and displays a "no classes specified" error message. MONITOR does not recognize these classes if they are the only classes specified on the command line, and displays a "no classes specified" error message.

The CLUSTER class includes the following data items:

Data Item	Description
CPU Busy	Percentage of CPU in use; includes activity in all processor modes (except Idle Time) for each node.
Percent Memory In Use	Memory in use on each node; calculated by dividing the Free List Size by total available memory and subtracting the result from 100%.
I/O Operation Rate	Total rate of disk I/O operations on each disk by all nodes currently active in the request. In cluster configurations, the MSCP server software makes locally attached and HSC disks available to other nodes. A node uses <i>remote</i> access to a disk when it accesses the disk through another VAX node (using the MSCP server). A node uses <i>direct</i> access to a disk when it directly accesses a locally attached or HSC disk. An "R" following the device name indicates that the displayed statistics represent I/O operations requested by nodes using remote access. If an "R" does not appear after the device name, the displayed statistics represent I/O operations issued by nodes with direct access. These I/O operations might include those issued by the MSCP server on behalf of remote requests.
Total ENQ/DEQ Rate	Sum of all local, incoming, and outgoing ENQs, DEQs, and conversions.

Two display formats are provided, depending on the classname qualifier specified:

- A tabular style format for the /ALL qualifier
- A bar graph style format for the /AVERAGE, /CURRENT, /MAXIMUM, and /MINIMUM qualifiers

Beginning in OpenVMS Version 7.3, the range of rate fields has been increased in the MONITOR CLUSTER screen display as follows:

Rate Name	Old Rate	New Rate
I/O Operation	0 - 25 - 50 - 75 - 100	0 - 125 - 250 - 375 - 500
Lock	Scale from 0 to 500	Scale from 0 to 1000

### Note to Cluster Managers on MONITOR\_SERVER Process

When users enter the MONITOR CLUSTER command, MONITOR activates the image SYS\$SYSTEM:VPM.EXE, which creates a process called MONITOR\_SERVER on each **remote** cluster node. (If users specify the /NODE qualifier with

## MONITOR MONITOR CLUSTER

the MONITOR CLUSTER command or with any command of the form MONITOR class name, MONITOR creates the process only on the specified nodes.) The server process gathers data from remote nodes for live display or to record on the local node. To ensure accurate and timely data collection, the process is started at priority 15. Because server processes consume minimal resources, they have no significant effect on system performance.

By default, MONITOR\_SERVER processes are started in the system DECnet account, which is created when the NETCONFIG.COM command procedure executes at bootstrap time. If this account is not present on your system, you must either create it by executing NETCONFIG.COM, or specify another account in which the server processes can be started.

If you want to start the processes in another account, use the following sequence of commands to define VPM as known object 51 in the DECnet database and associate the object with the desired account:

```
$ SET PROCESS/PRIVILEGE=SYSPRV
$ RUN SYS$SYSTEM:NCP
NCP> DEFINE OBJECT VPM NUMBER 51 -
  FILE SYS$SYSTEM:VPM.EXE -
  PROXY NONE -
  ACCOUNT account -
  USER user-id -
  PASSWORD password
NCP> SET OBJECT VPM NUMBER 51 -
  FILE SYS$SYSTEM:VPM.EXE -
  PROXY NONE -
  ACCOUNT account -
  USERNAME user-id -
  PASSWORD password
NCP> EXIT
$ SET PROCESS/PRIVILEGE=NOSYSPRV
```

For each server process, MONITOR creates a log file on the local node to which information about server connection activity, including error messages, is written. Note that error messages are written to the file only when errors occur. A single version is maintained for the life of the system. The default file specification has the form SYS\$COMMON:[SYSMGR]VPM\$nodename.LOG. The node name portion of the specification identifies the node on which the MONITOR\_SERVER process has been started.

If you want to change the default specification, you can redefine the executive-mode logical name VPM\$LOG\_FILE in the system logical name table on the appropriate nodes. For example, if you wanted to write server error logging data to the file WRKD:[MONSERVER]VPM\_ERRORS.LOG, you would define VPM\$LOG\_FILE as follows:

```
$ DEFINE/SYSTEM/EXECUTIVE MODE VPM$LOG_FILE -
_$ WRKD:[MONSERVER]VPM_ERRORS.LOG
```

To direct to a single file data for all MONITOR\_SERVER processes on the cluster, you could assign the logical name the same value on each member system. Note that because the log files are created as shared sequential files, multiple server processes can access them simultaneously.

If you routinely monitor your cluster, you can reduce server startup time significantly by creating MONITOR\_SERVER processes on each member node at bootstrap time and maintaining the processes for the life of the system. To do so, add the following lines to the appropriate site-independent startup command files:

# MONITOR MONITOR CLUSTER

```
$ DEFINE/SYSTEM/EXECUTIVE MODE VPM$SERVER LIVE TRUE
$ RUN/DETACH/PAGE_FILE=10000 SYSS$SYSTEM:VPM.EXE
```

You can enter these commands interactively at any time if you have the following privileges: ALTPRI, NETMBX, PSWAPM, SYSNAM, SYSPRV, and TMPMBX.

## Example

```
MONITOR> MONITOR CLUSTER/ALL
```

```
OpenVMS Monitor Utility
CLUSTER STATISTICS
on node CURLEY
29-APR-2003 12:25:13
```

CPU Busy	CUR	AVE	MIN	MAX
LARRY	100.00	100.00	100.00	100.00
CURLEY	100.00	99.83	100.00	100.00
MOE	8.52	8.50	8.52	8.52

```
OpenVMS Monitor Utility
CLUSTER STATISTICS
on node CURLEY
29-APR-2003 12:25:19
```

%Memory In Use	CUR	AVE	MIN	MAX
MOE	88.00	88.00	88.00	88.00
LARRY	78.00	78.00	77.00	78.00
CURLEY	72.00	72.50	72.00	72.00

```
OpenVMS Monitor Utility
CLUSTER STATISTICS
on node CURLEY
29-APR-2003 12:25:25
```

I/O Operation Rate	CUR	AVE	MIN	MAX
\$111\$DUA7: (DECEIT) SQMCLUSTERV4	0.48	6.53	0.48	10.41
\$111\$DUA6: (DECEIT) QUALD	1.93	1.07	0.00	1.93
\$111\$DUA4: (DECEIT) PAGESWAPDISK	1.44	0.96	0.00	1.44
\$111\$DUA2: (DECEIT) TSDPERF	0.32	0.53	0.16	1.12
LARRY\$DRA3: QUALQUEST	0.00	0.21	0.00	0.64
MOE\$DMA1: UVMSQAR	0.00	0.00	0.00	0.00
MOE\$DRA5: USER01	0.00	0.00	0.00	0.00
LARRY\$DRA4: TIMEDEV	0.00	0.00	0.00	0.00
LARRY\$DBB3: REGLIB	0.00	0.00	0.00	0.00
\$111\$DUA3: (DECEIT) DUMPDISK	0.00	0.00	0.00	0.00
\$111\$DUA5: (DECEIT) BPMDISK	0.00	0.00	0.00	0.00
\$111\$DJA8: (DECEIT) ORLEAN	0.00	0.00	0.00	0.00
\$111\$DJA10: (DECEIT) QMISDATABASE	0.00	0.00	0.00	0.00
\$111\$DJA9: (DECEIT) MPI\$DATA	0.00	0.00	0.00	0.00



# MONITOR MONITOR CLUSTER

```
OpenVMS Monitor Utility
CLUSTER STATISTICS
on node CURLEY
29-APR-2003 12:25:56
```

Tot ENQ/DEQ Rate	CUR	AVE	MIN	MAX
MOE	7.90	14.92	0.00	43.12
LARRY	20.48	14.64	0.00	46.92
CURLEY	1.93	13.29	0.00	57.30

The preceding example shows the tabular style format for the CLUSTER display.

MONITOR> MONITOR CLUSTER/CURRENT

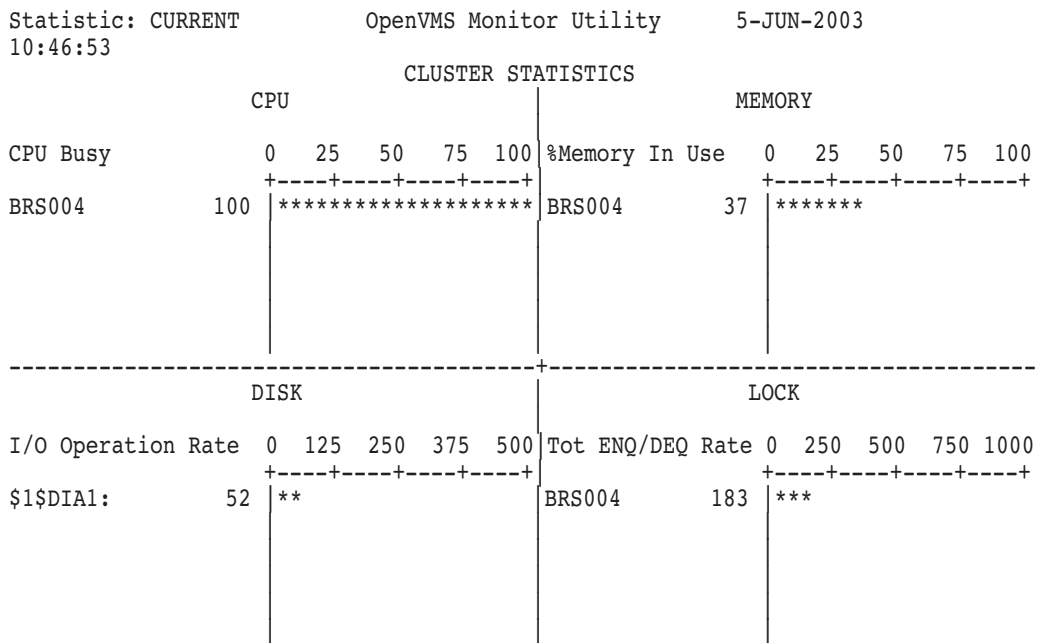

The preceding example shows the bar graph style format for a CLUSTER/CURRENT display.

# MONITOR MONITOR DECNET

---

## MONITOR DECNET

The MONITOR DECNET command initiates monitoring of the DECNET class, which includes information about DECnet for OpenVMS network activity.

### Format

MONITOR DECNET

### Command Qualifiers

**/qualifier[,...]**

One or more qualifiers as described in the Command Qualifier Descriptions section.

### Classname Qualifiers

**/ALL**

Specifies that a table of all available statistics (current, average, minimum, and maximum) is to be included in the display and summary output. For summary output, this qualifier is the default for all classes; otherwise, it is the default for all classes except CLUSTER, MODES, PROCESSES, STATES, SYSTEM, and VECTOR.

**/AVERAGE**

Specifies that a bar graph of average statistics is to be included in the display and summary outputs.

**/CURRENT**

Specifies that a bar graph of current statistics is to be included in the display and summary outputs. The /CURRENT qualifier is the default for the CLUSTER, MODES, STATES, SYSTEM, and VECTOR classes.

**/MAXIMUM**

Specifies that a bar graph of maximum statistics is to be included in the display and summary outputs.

**/MINIMUM**

Specifies that a bar graph of minimum statistics is to be included in the display and summary outputs.

### Description

The DECNET class consists of the following data items:

Data Item	Description
Arriving Local Packet Rate	Rate at which local packets are being received.
Departing Local Packet Rate	Rate at which local packets are being sent.
Arriving Transit Packet Rate	Rate at which transit packets are arriving.
Transit Congestion Loss Rate	Rate of transit congestion loss.
Receiver Buffer Failure Rate	Rate of receiver buffer failures.

**Example**

MONITOR> MONITOR DECNET

```
OpenVMS Monitor Utility
DECNET STATISTICS
on node SAMPLE
29-APR-2003 22:22:44
```

	CUR	AVE	MIN	MAX
Arriving Local Packet Rate	9.54	5.08	0.00	11.25
Departing Local Packet Rate	9.22	4.66	0.00	10.92
Arriving Trans Packet Rate	0.00	0.00	0.00	0.00
Trans Congestion Loss Rate	0.00	0.00	0.00	0.00
Receiver Buff Failure Rate	0.00	0.00	0.00	0.00

This example shows that arriving and departing network packet rates (including control packets) are roughly equivalent, and that network activity is currently at a level higher than the average since monitoring began, but not at its highest point.

# MONITOR MONITOR DISK

---

## MONITOR DISK

The MONITOR DISK command initiates monitoring of the DISK statistics class. The maximum number of disks that can be monitored for record output is 909, and for display and summary output is 1817.

### Format

MONITOR DISK

### Command Qualifiers

**/qualifier[,...]**

One or more qualifiers as described in the Command Qualifier Descriptions section.

### Classname Qualifiers

**/ALL**

Specifies that a table of all available statistics (current, average, minimum, and maximum) is to be included in the display and summary output. For summary output, this qualifier is the default for all classes; otherwise, it is the default for all classes except CLUSTER, MODES, PROCESSES, STATES, SYSTEM, and VECTOR.

**/AVERAGE**

Specifies that a bar graph of average statistics is to be included in the display and summary outputs.

**/CURRENT**

Specifies that a bar graph of current statistics is to be included in the display and summary outputs. The /CURRENT qualifier is the default for the CLUSTER, MODES, STATES, SYSTEM, and VECTOR classes.

**/ITEM=(keyword[,...])**

Selects one or more data items for inclusion in display and summary outputs. If you specify two or more keywords, enclose them in parentheses, and separate them with commas. When the /ITEM qualifier is omitted, the default is /ITEM=OPERATION\_RATE.

The following table describes /ITEM qualifier keywords:

Keyword	Description
ALL	Specifies that statistics on all data items collected for the disks are displayed on successive screens.
OPERATION_RATE	Specifies that I/O operation rate statistics are displayed for each disk.
QUEUE_LENGTH	Specifies that the number of I/O request packets being serviced (current or waiting) is displayed for each disk.

**/MAXIMUM**

Specifies that a bar graph of maximum statistics is to be included in the display and summary outputs.

**/MINIMUM**

Specifies that a bar graph of minimum statistics is to be included in the display and summary outputs.

**/PERCENT**

**/NOPERCENT (default)**

Controls whether statistics are expressed as percent values in display and summary outputs. The /PERCENT qualifier is applicable only to the DISK, MODES, SCS, and STATES classes.

**Description**

The DISK class is a component class. Data items for this class are collected for each mounted disk device in a single-node or cluster system. The DISK class consists of the following data items:

Data Item	Description
I/O Operation Rate	Rate at which I/O operations occur on each disk. By comparing operation rates for all disks in the system, you can tell which disks are busy and which are idle. However, because this statistic does not provide information about the time required for individual operations, use discretion in interpreting it.
I/O Request Queue Length	Number of outstanding I/O request packets. Includes the request currently being serviced and those awaiting service. Note that, for greater precision, this item is always sampled at a 1-second interval, regardless of the value specified with the /INTERVAL command qualifier.  The maximum number of disks that can be monitored is 909 for record output and 1817 for display or summary output. In previous versions, the limit was 799 disks for both types of output.

In the following example, typical of a cluster environment, note that each disk is identified by three elements:

- Disk name ending in a colon.
- Name of the cluster node through which the disk is accessed. This field appears only in the multiple-statistic display; it is not included in single-statistic displays or multifile summaries.
- Volume label.

In cluster configurations, the MSCP server software makes locally attached and HSC disks available to other nodes. A node uses *remote* access to a disk when it accesses the disk through another VAX node (using the MSCP server). A node uses *direct* access to a disk when it directly accesses a locally attached or HSC disk.

An “R” following the device name indicates that the displayed statistics represent I/O operations requested by nodes using remote access.

## MONITOR MONITOR DISK

If an "R" does not appear after the device name, the displayed statistics represent I/O operations issued by nodes with direct access. These I/O operations might include those issued by the MSCP server on behalf of remote requests.

### Example

```
MONITOR> MONITOR DISK/ITEM=QUEUE_LENGTH
```

```
OpenVMS Monitor Utility
DISK I/O STATISTICS
on node SAMPLE
29-APR-2003 14:19:56
```

I/O Request	Queue Length	CUR	AVE	MIN	MAX
SAMPLE\$DBA0:	SAMPLE09APR	0.00	0.00	0.00	0.00
SAMPLE\$DRA2:	SAMPLEPAGE	2.00	1.43	0.00	4.00
SAMPLE\$DRB1:	ACCREG	0.00	0.00	0.00	0.00
\$1\$DRA5:	(MOE) MOE\$\$PAGE	0.00	0.00	0.00	0.00
\$1\$DBA3:	(CURLEY) UMASTER	0.00	0.00	0.00	0.00
\$1\$DBA5:	(CURLEY) MIDNITE	0.00	0.00	0.00	0.00
\$2\$DRA7:	(LARRY) RES26APR	0.00	0.00	0.00	0.00
\$2\$DRB6:	(LARRY) CLUSTERDUMP1	0.00	0.00	0.00	0.00
\$255\$DUA4:	(SHEMP) RES06AUG	0.00	0.00	0.00	0.00
\$255\$DUA5:	(SHEMP) VMSDOCLIB	0.00	0.00	0.00	0.00

This example, typical of a cluster environment, shows the number of I/O packets awaiting service or in service for each disk. Note that the device SAMPLE\$DRA2 is the only device with a nonzero queue length. Because MONITOR samples queue lengths every second, regardless of the collection interval value, the precision of the data does not depend on the collection interval.

---

## MONITOR DLOCK

The MONITOR DLOCK command initiates monitoring of the DLOCK (distributed lock management) statistics class.

### Format

MONITOR DLOCK

### Command Qualifiers

**/qualifier[,...]**

One or more qualifiers as described in the Command Qualifier Descriptions section.

### Classname Qualifiers

**/ALL**

Specifies that a table of all available statistics (current, average, minimum, and maximum) is to be included in the display and summary output. For summary output, this qualifier is the default for all classes; otherwise, it is the default for all classes except CLUSTER, MODES, PROCESSES, STATES, SYSTEM, and VECTOR.

**/AVERAGE**

Specifies that a bar graph of average statistics is to be included in the display and summary outputs.

**/CURRENT**

Specifies that a bar graph of current statistics is to be included in the display and summary outputs. The /CURRENT qualifier is the default for the CLUSTER, MODES, STATES, SYSTEM, and VECTOR classes.

**/MAXIMUM**

Specifies that a bar graph of maximum statistics is to be included in the display and summary outputs.

**/MINIMUM**

Specifies that a bar graph of minimum statistics is to be included in the display and summary outputs.

### Description

The DLOCK class is useful for monitoring the lock management subsystem in a cluster environment. The class consists of the following data items:

Data Item	Description
New ENQ Rate (Local)	Rate of new lock (ENQ) requests that originate and are performed on this system
New ENQ Rate (Incoming)	Rate of new lock requests that originate on other systems and are performed on this system

## MONITOR MONITOR DLOCK

Data Item	Description
New ENQ Rate (Outgoing)	Rate of new lock requests that originate on this system and are performed on another system
Converted ENQ Rate (Local)	Rate of lock (ENQ) conversion requests that originate and are performed on this system
Converted ENQ Rate (Incoming)	Rate of lock conversion requests that originate on other systems and are performed on this system
Converted ENQ Rate (Outgoing)	Rate of lock conversion requests that originate on this system and are performed on another system
DEQ Rate (Local)	Rate of unlock (DEQ) requests that originate and are performed on this system
DEQ Rate (Incoming)	Rate of unlock requests that originate on other systems and are performed on this system
DEQ Rate (Outgoing)	Rate of unlock requests that originate on this system and are performed on another system
Blocking AST Rate (Local)	Rate of lock manager blocking ASTs that originate and are performed on this system
Blocking AST Rate (Incoming)	Rate of lock manager blocking ASTs that originate on other systems and are performed on this system
Blocking AST Rate (Outgoing)	Rate of lock manager blocking ASTs that originate on this system and are performed on another system
Directory Function Rate (Incoming)	Rate of requests for locks being managed by this node
Directory Function Rate (Outgoing)	Rate of requests for locks being managed by other nodes
Deadlock Message Rate	Rate of incoming and outgoing messages required for deadlock detection



# MONITOR MONITOR DLOCK

## Example

MONITOR> MONITOR DLOCK

```
OpenVMS Monitor Utility
DISTRIBUTED LOCK MANAGEMENT STATISTICS
on node SAMPLE
29-APR-2003 11:02:20
```

	CUR	AVE	MIN	MAX
New ENQ Rate (Local)	15.84	11.59	1.54	26.88
(Incoming)	1.67	2.62	0.11	25.05
(Outgoing)	0.05	0.63	0.00	5.99
Converted ENQ Rate (Local)	23.67	9.13	0.99	41.22
(Incoming)	4.48	5.71	0.00	70.19
(Outgoing)	0.00	1.43	0.00	15.90
DEQ Rate (Local)	15.86	11.58	1.64	26.68
(Incoming)	1.66	2.59	0.00	24.85
(Outgoing)	0.05	0.63	0.00	5.99
Blocking AST Rate (Local)	0.00	0.00	0.00	0.01
(Incoming)	0.00	0.00	0.00	0.00
(Outgoing)	0.00	0.00	0.00	0.00
Dir Functn Rate (Incoming)	8.00	7.33	4.66	11.00
(Outgoing)	1.00	0.77	0.00	2.66
Deadlock Message Rate	0.00	0.00	0.00	0.00

This example shows that most of the current lock management activity occurs locally, but that, at some point during the monitoring period, a significant amount of incoming activity occurred.

# MONITOR

## MONITOR FCP

---

### MONITOR FCP

The MONITOR FCP command initiates monitoring of the File Control Primitive statistics class, which includes information about all Files-11 ancillary control processes (ACPs) and extended QIO processors (XQPs) on the local node.

#### Format

MONITOR FCP

#### Command Qualifiers

**/qualifier[,...]**

One or more qualifiers as described in the Command Qualifier Descriptions section.

#### Classname Qualifiers

**/ALL**

Specifies that a table of all available statistics (current, average, minimum, and maximum) is to be included in the display and summary output. For summary output, this qualifier is the default for all classes; otherwise, it is the default for all classes except CLUSTER, MODES, PROCESSES, STATES, SYSTEM, and VECTOR.

**/AVERAGE**

Specifies that a bar graph of average statistics is to be included in the display and summary outputs.

**/CURRENT**

Specifies that a bar graph of current statistics is to be included in the display and summary outputs. The /CURRENT qualifier is the default for the CLUSTER, MODES, STATES, SYSTEM, and VECTOR classes.

**/MAXIMUM**

Specifies that a bar graph of maximum statistics is to be included in the display and summary outputs.

**/MINIMUM**

Specifies that a bar graph of minimum statistics is to be included in the display and summary outputs.

#### Description

The FCP class consists of the following data items, all of which are displayed as occurrences per second:

Data Item	Description
FCP Call Rate	Rate of QIO requests received by the file system.
Allocation Rate	Rate of calls that caused allocation of disk space.
Create Rate	Rate at which new files were created.
Disk Read Rate	Rate of read I/O operations from disk by the file system.

Data Item	Description
Disk Write Rate	Rate of write I/O operations to disk by the file system.
Volume Lock Wait Rate	Rate of entry into a wait state due to contention for a volume synchronization lock. Volume synchronization locks are removed by the XQP during file creation, deletion, extension, and truncation operations.
CPU Tick Rate	Rate at which CPU time was used by the file system (in 10-millisecond ticks).
File System Page Fault Rate	Rate at which page faults occurred in the file system.
Window Turn Rate	Rate of file-map window misses.
File Lookup Rate	Rate of file name lookup operations in file directories.
File Open Rate	Rate at which files were opened.
Erase Rate	Rate of erase operations issued by the file system.

### Example

```
MONITOR> MONITOR /INTERVAL=10 FCP
```

```

OpenVMS Monitor Utility
FILE PRIMITIVE STATISTICS
on node SAMPLE
29-APR-2003 16:13:38

```

	CUR	AVE	MIN	MAX
FCP Call Rate	4.62	3.80	0.33	7.61
Allocation Rate	0.99	0.24	0.00	0.99
Create Rate	2.31	0.57	0.00	2.31
Disk Read Rate	1.98	2.48	0.33	6.95
Disk Write Rate	3.30	2.39	0.33	5.62
Volume Lock Wait Rate	4.62	3.06	0.00	6.95
CPU Tick Rate	3.63	3.88	0.33	10.26
File Sys Page Fault Rate	0.00	0.00	0.00	0.00
Window Turn Rate	1.98	0.99	0.00	1.98
File Lookup Rate	0.33	1.40	0.00	4.63
File Open Rate	2.00	3.54	2.00	5.10
Erase Rate	0.00	0.00	0.00	0.00

This example shows that the rate of files opened during the last 10-second collection interval was 2.0 (for a total of 20). The average rate since the MONITOR command was entered is 3.54; the highest rate achieved during any 10-second interval is 5.10, and the lowest rate of 2.0 occurred during the last interval.

# MONITOR

## MONITOR FILE\_SYSTEM\_CACHE

---

### MONITOR FILE\_SYSTEM\_CACHE

The MONITOR FILE\_SYSTEM\_CACHE command initiates monitoring of the FILE\_SYSTEM\_CACHE statistics class.

#### Format

MONITOR FILE\_SYSTEM\_CACHE

#### Command Qualifiers

**/qualifier[,...]**

One or more qualifiers as described in the Command Qualifier Descriptions section.

#### Classname Qualifiers

**/ALL**

Specifies that a table of all available statistics (current, average, minimum, and maximum) is to be included in the display and summary output. For summary output, this qualifier is the default for all classes; otherwise, it is the default for all classes except CLUSTER, MODES, PROCESSES, STATES, SYSTEM, and VECTOR.

**/AVERAGE**

Specifies that a bar graph of average statistics is to be included in the display and summary outputs.

**/CURRENT**

Specifies that a bar graph of current statistics is to be included in the display and summary outputs. The /CURRENT qualifier is the default for the CLUSTER, MODES, STATES, SYSTEM, and VECTOR classes.

**/MAXIMUM**

Specifies that a bar graph of maximum statistics is to be included in the display and summary outputs.

**/MINIMUM**

Specifies that a bar graph of minimum statistics is to be included in the display and summary outputs.

#### Description

The FILE\_SYSTEM\_CACHE class includes the following data items:

Data Item	Description
Directory FCB Hit%	Percentage of directory file control block hits on the directory cache. The percentage value shown is the ratio of hits to the sum of hits plus misses.
Directory FCB Attempt Rate	Rate at which attempts were made to find directory file control blocks in the directory cache.

**MONITOR  
MONITOR FILE\_SYSTEM\_CACHE**

<b>Data Item</b>	<b>Description</b>
Directory Data Hit%	Percentage of directory data hits on the directory cache. The percentage value shown is the ratio of hits to the sum of hits plus misses.
Directory Data Attempt Rate	Rate at which attempts were made to find directory data in the directory cache.
File Header Hit%	Percentage of file header hits on the file header cache. The percentage value shown is the ratio of hits to the sum of hits plus misses.
File Header Attempt Rate	Rate at which attempts were made to find file headers in the file header cache.
File ID Hit%	Percentage of file identifier hits on the file ID cache. The percentage value shown is the ratio of hits to the sum of hits plus misses.
File ID Cache Attempt Rate	Rate at which attempts were made to find file identifiers in the file ID cache.
Extent Cache Hit%	Percentage of appropriate size extent hits on the extent cache. The percentage value shown is the ratio of hits to the sum of hits plus misses.
Extent Cache Attempt Rate	Rate at which attempts were made to find appropriate size extents in the extent cache.
Quota Cache Hit%	Percentage of quota entry hits on the quota cache. The percentage value shown is the ratio of hits to the sum of hits plus misses.
Quota Cache Attempt Rate	Rate at which attempts were made to find entries in the quota cache.
Bitmap Cache Hit%	Percentage of entry hits on the bitmap cache. The percentage value shown is the ratio of hits to the sum of hits plus misses.
Bitmap Cache Attempt Rate	Rate at which attempts were made to find entries in the bitmap cache.

Note that all items shown in the FILE\_SYSTEM\_CACHE display except Dir FCB apply only to XQPs. The Dir FCB item applies to both XQPs and the ODS-1 ACP.

# MONITOR

## MONITOR FILE\_SYSTEM\_CACHE

### Example

```
MONITOR> MONITOR FILE_SYSTEM_CACHE
```

```
OpenVMS Monitor Utility
FILE SYSTEM CACHING STATISTICS
on node SAMPLE
29-APR-2003 13:08:53
```

		CUR	AVE	MIN	MAX
Dir FCB	(Hit %)	100.00	100.00	0.00	100.00
	(Attempt Rate)	1.66	0.49	0.00	1.66
Dir Data	(Hit %)	100.00	100.00	0.00	100.00
	(Attempt Rate)	4.66	1.24	0.00	4.66
File Hdr	(Hit %)	66.00	80.00	0.00	100.00
	(Attempt Rate)	1.00	0.41	0.00	1.00
File ID	(Hit %)	0.00	0.00	0.00	0.00
	(Attempt Rate)	0.00	0.00	0.00	0.00
Extent	(Hit %)	0.00	100.00	0.00	100.00
	(Attempt Rate)	0.00	0.24	0.00	1.00
Quota	(Hit %)	0.00	100.00	0.00	100.00
	(Attempt Rate)	0.00	0.16	0.00	0.66
Bitmap	(Hit %)	0.00	0.00	0.00	0.00
	(Attempt Rate)	0.00	0.00	0.00	0.00

The cache hits and misses reflect the effectiveness of file system caching. Generally, the size of the cache affects the hit rate. The Attempt Rate is the sum of hits plus misses; the Hit% is the percentage of attempts that were successful.

Unlike other MONITOR data items, the averages for the hit percentages are not calculated based on previous hit percentages. Instead, these values are calculated based on the total number of hits and the total number of attempts on a cache since the beginning of the Monitor request. This provides more accurate average values for the hit percentage items.

The **directory FCB cache** is checked whenever a directory lookup is performed. Directory lookups can be performed on file open, creation, deletion, extension, or truncation. If the file control block associated with the directory is found in the cache, a hit is recorded. Otherwise, a miss is recorded. Both hits and misses are counted as attempts.

The **directory data cache** is checked whenever a file lookup is performed. Directory lookups may be performed on file open, creation, deletion, extension, or truncation. If an entry for the file being accessed is found in the directory data cache, a hit is recorded. Otherwise, a miss is recorded. Both hits and misses are counted as attempts.

The **file header cache** is checked on file open, close, creation, deletion, extension, or truncation. If the file header for the file being accessed is found in the file header cache, a hit is recorded. Otherwise, a miss is recorded. Both hits and misses are counted as attempts.

## MONITOR MONITOR FILE\_SYSTEM\_CACHE

The **file identification cache** is a list of file identifiers that are removed on file creation and returned on file deletion. The File ID hits indicate file numbers successfully removed or returned to the file ID cache. Otherwise, a miss is recorded. Both hits and misses are counted as attempts.

The **extent cache** is checked on file creation, deletion, extension, and truncation. An attempt is made to allocate space from the extent cache during file creation or extension. During file creation, if sufficient size is found, a hit is recorded. If the desired size is not found, or an entry is forced to be split, an attempt is recorded. During file deletion, if the blocks were returned to the cache without the extent cache becoming too large, a hit is recorded. Otherwise, a miss is recorded. Both hits and misses are counted as attempts.

If quota checking is enabled, the **quota cache** is checked on file creation, deletion, extension, and truncation. If the desired entry (the identifier matching that of the requester) is found in the quota cache, a hit is recorded. Otherwise, a miss is recorded. Both hits and misses are counted as attempts.

The **bitmap cache** contains blocks from the storage bitmap file. This cache is accessed when the extent cache cannot satisfy requests for disk space. High rates indicate fragmented volumes.

Data items in the FILE\_SYSTEM\_CACHE display correspond to SYSGEN ACP/XQP parameters, as follows:

FILE_SYSTEM_CACHE Item	ACP/XQP Parameters
Dir FCB	ACP_SYSACC ACP_DINDXCACHE
Dir Data	ACP_DIRCACHE
File Hdr	ACP_HDRCACHE
File ID	ACP_FIDCACHE
Extent	ACP_EXTCACHE ACP_EXTLIMIT
Quota	ACP_QUOCACHE
Bitmap	ACP_MAPCACHE

When you change the ACP/XQP cache parameters, remember to reboot the system to make the changes effective. For more information about these parameters, see Appendix D.

# MONITOR MONITOR IO

---

## MONITOR IO

The MONITOR IO command initiates monitoring of the I/O class.

### Format

MONITOR IO

### Command Qualifiers

**/qualifier[,...]**

One or more qualifiers as described in the Command Qualifier Descriptions section.

### Classname Qualifiers

**/ALL**

Specifies that a table of all available statistics (current, average, minimum, and maximum) is to be included in the display and summary output. For summary output, this qualifier is the default for all classes; otherwise, it is the default for all classes except CLUSTER, MODES, PROCESSES, STATES, SYSTEM, and VECTOR.

**/AVERAGE**

Specifies that a bar graph of average statistics is to be included in the display and summary outputs.

**/CURRENT**

Specifies that a bar graph of current statistics is to be included in the display and summary outputs. The /CURRENT qualifier is the default for the CLUSTER, MODES, STATES, SYSTEM, and VECTOR classes.

**/MAXIMUM**

Specifies that a bar graph of maximum statistics is to be included in the display and summary outputs.

**/MINIMUM**

Specifies that a bar graph of minimum statistics is to be included in the display and summary outputs.

### Description

The IO class includes the following data items:

<b>Data Item</b>	<b>Description</b>
Direct I/O Rate	Rate of direct I/O (for example, disk and tape) operations
Buffered I/O Rate	Rate of buffered I/O (for example, terminal and line printer) operations
Mailbox Write Rate	Rate of write-to-mailbox requests received by the system
Split Transfer Rate	Rate at which transfers were split into multiple I/Os



# MONITOR MONITOR IO

Data Item	Description
Log Name Translation Rate	Rate of logical name translations
File Open Rate	Rate at which files were opened
Page Fault Rate	Rate of occurrence of page faults for all working sets
Page Read Rate	Rate of pages read from disk as a result of page faults
Page Read I/O Rate	Rate of read I/O operations from disk as a result of page faults
Page Write Rate	Rate of pages written to the page file
Page Write I/O Rate	Rate of write I/O operations to the page file
Inswap Rate	Rate at which working sets were read into memory from the swap file
Free List Size	Number of pages on the free page list
Modified List Size	Number of pages on the modified page list

## Example

```
MONITOR> MONITOR /RECORD IO
```

```

OpenVMS Monitor Utility
I/O SYSTEM STATISTICS
on node SAMPLE
29-APR-2003 22:22:44

```

	CUR	AVE	MIN	MAX
Direct I/O Rate	15.33	4.46	0.33	15.33
Buffered I/O Rate	24.91	47.47	24.91	69.00
Mailbox Write Rate	0.00	0.45	0.00	2.95
Split Transfer Rate	1.66	1.56	0.33	3.97
Log Name Translation Rate	13.28	10.75	3.66	27.66
File Open Rate	1.66	1.26	0.33	2.98
Page Fault Rate	24.58	52.31	17.33	178.00
Page Read Rate	12.29	9.00	0.00	26.88
Page Read I/O Rate	2.65	2.43	0.00	6.22
Page Write Rate	0.00	6.69	0.00	58.66
Page Write I/O Rate	0.00	0.27	0.00	1.66
Inswap Rate	0.00	0.00	0.00	0.00
Free List Size	3621.00	3604.09	3392.00	3771.00
Modified List Size	49.00	73.36	4.00	181.00

RECORDING

This example shows that the direct I/O rate is currently at its highest level since the MONITOR command was entered and is significantly higher than the average rate. Termination of this command by Ctrl/C and entry of a MONITOR PROCESSES/TOPDIO command would show the top users of direct I/Os. Note that if I/O monitoring is begun at a later time, a new MONITOR request is defined. That is, it is not a continuation of the original request; the average, minimum, and maximum statistics are reinitialized. However, because the original request specified recording, that data can be played back for redisplay or summarization.

# MONITOR MONITOR LOCK

---

## MONITOR LOCK

The MONITOR LOCK command initiates monitoring of the LOCK class.

### Format

MONITOR LOCK

### Command Qualifiers

**/qualifier[,...]**

One or more qualifiers as described in the Command Qualifier Descriptions section.

### Classname Qualifiers

**/ALL**

Specifies that a table of all available statistics (current, average, minimum, and maximum) is to be included in the display and summary output. For summary output, this qualifier is the default for all classes; otherwise, it is the default for all classes except CLUSTER, MODES, PROCESSES, STATES, SYSTEM, and VECTOR.

**/AVERAGE**

Specifies that a bar graph of average statistics is to be included in the display and summary outputs.

**/CURRENT**

Specifies that a bar graph of current statistics is to be included in the display and summary outputs. The /CURRENT qualifier is the default for the CLUSTER, MODES, STATES, SYSTEM, and VECTOR classes.

**/MAXIMUM**

Specifies that a bar graph of maximum statistics is to be included in the display and summary outputs.

**/MINIMUM**

Specifies that a bar graph of minimum statistics is to be included in the display and summary outputs.

### Description

The LOCK class includes the following data items:

<b>Data Item</b>	<b>Description</b>
New ENQ Rate	Rate of new lock (ENQ) requests (as opposed to conversions)
Converted ENQ Rate	Rate of lock (ENQ) conversion requests
DEQ Rate	Rate of unlock (DEQ) requests
Blocking AST Rate	Rate of lock manager blocking ASTs delivered

# MONITOR MONITOR LOCK

Data Item	Description
ENQs Forced To Wait Rate	Rate of occurrence of locks that could not be granted immediately, thus causing a wait
ENQs Not Queued Rate	Rate of occurrence of locks that could not be granted immediately but requested not to be queued, and thus received an error status instead
Deadlock Search Rate	Rate at which a deadlock search was performed
Deadlock Find Rate	Rate at which deadlocks were found
Total Locks	Total number of locks in the system
Total Resources	Total number of resources in the system

## Example

```
MONITOR> MONITOR /RECORD IO
MONITOR> MONITOR /INPUT=LOCKSTATS.DAT/SUMMARY/NODISPLAY LOCK/AVERAGE
.
.
MONITOR> Ctrl/Z
$ TYPE MONITOR.SUM
```

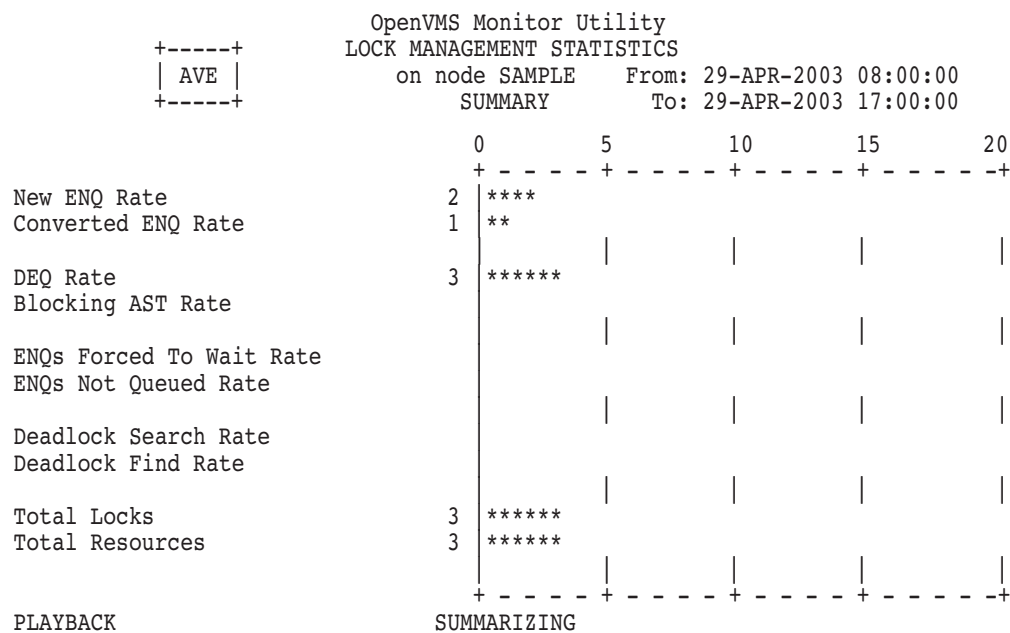

This example shows the average use of the lock management subsystem during a typical workday, based on data that was previously recorded.

# MONITOR

## MONITOR MODES

---

### MONITOR MODES

The MONITOR MODES command initiates monitoring of the MODES class, which includes a data item for each mode of processor operation.

#### Format

MONITOR MODES

#### Command Qualifiers

**/qualifier[,...]**

One or more qualifiers as described in the Command Qualifier Descriptions section.

#### Classname Qualifiers

**/ALL**

Specifies that a table of all available statistics (current, average, minimum, and maximum) is to be included in the display and summary output. For summary output, this qualifier is the default for all classes; otherwise, it is the default for all classes except CLUSTER, MODES, PROCESSES, STATES, SYSTEM, and VECTOR.

**/AVERAGE**

Specifies that a bar graph of average statistics is to be included in the display and summary outputs.

**/CPU**

**/NOCPU [= (x[,...])] (default)**

In multiprocessor configurations, selects the CPU-specific form of output, where *x* specifies the CPU identification. If you specify /CPU without specifying a CPU identification, MONITOR displays MODES class statistics for each successive CPU until information for all active CPUs has been displayed. MONITOR then repeats the cycle beginning with the first CPU. If you specify one CPU identification, MONITOR displays statistics for that CPU only. If you specify multiple CPU identifications, MONITOR displays statistics for each successive CPU specified, then repeats the cycle beginning with the first specified CPU.

Note that if you specify multiple CPU identifications, MONITOR does not notify you if one or more of the specified CPUs is unavailable. If all of the CPU identifications that you specify do not exist, then MONITOR will behave as if /CPU were specified without any arguments.

For multiprocessor systems, /NOCPU produces a single modes screen that reflects the combined time that all CPUs spent in each mode.

For nonmultiprocessor systems, the /CPU qualifier displays the CPU ID; /NOCPU does not display the CPU ID.

**/CURRENT**

Specifies that a bar graph of current statistics is to be included in the display and summary outputs. The /CURRENT qualifier is the default for the CLUSTER, MODES, STATES, SYSTEM, and VECTOR classes.

**/MAXIMUM**

Specifies that a bar graph of maximum statistics is to be included in the display and summary outputs.

**/MINIMUM**

Specifies that a bar graph of minimum statistics is to be included in the display and summary outputs.

**/PERCENT**

**/NOPERCENT (default)**

Controls whether statistics are expressed as percent values in display and summary outputs. The [NO]PERCENT qualifier is applicable only to the DISK, MODES, SCS, and STATES classes.

**Description**

The following data items, included in the MODES class, can be displayed as percentages of all processor (CPU) time or as rates of clock ticks (10 millisecond units) per second:

<b>Data Item</b>	<b>Description</b>
Interrupt State	Time spent on the interrupt state on a kernel stack.
MP Synchronization	Time spent synchronizing multiple CPUs (applicable to multiprocessor systems only).
Kernel Mode	Time spent in kernel mode, but not in an interrupt state.
Executive Mode	Time spent in executive mode.
Supervisor Mode	Time spent in supervisor mode.
User Mode	Time spent in user mode executing instructions.
Idle Time	Time not spent in any of the other modes.

For multiprocessor systems, when you enter the MONITOR MODES command without using the /CPU qualifier to select specific CPUs, MONITOR produces a single modes screen similar to those produced for nonmultiprocessor systems. However, the statistics produced for multiprocessor systems reflect the combined time that all CPUs spent in each mode.

# MONITOR MONITOR MODES

## Examples

1. MONITOR> MONITOR MODES /PERCENT

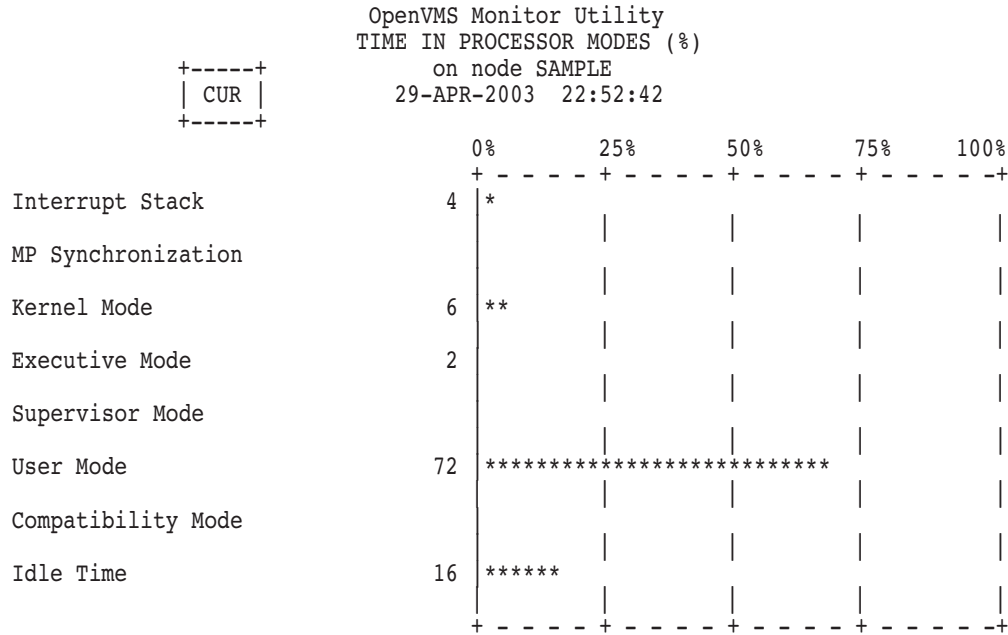

This display shows that, over the last collection interval, the processor spent 72 percent of its time executing user code, 8 percent executing system code to service user requests in executive and kernel modes, and 4 percent processing interrupts on the interrupt stack. It was idle 16 percent of the time. Time spent executing OpenVMS RMS code is included in executive-mode time. Time spent executing DCL code is included in supervisor-mode time.

If you omit the /PERCENT qualifier or specify /NOPERCENT, MONITOR displays mode times as rates of clock ticks per second, where a clock tick is 10 milliseconds. On a uniprocessor, the rate value is equivalent to the percent value.

# MONITOR MONITOR MODES

## 2. MONITOR> MONITOR MODES

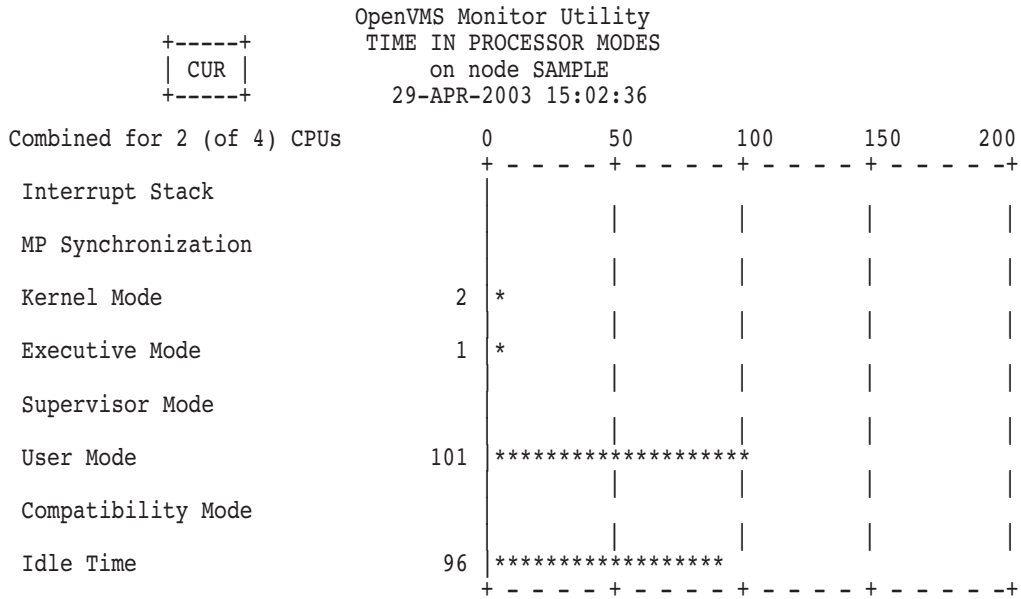

This example demonstrates output of the MONITOR MODES command for a multiprocessor system. Displayed statistics represent rates of clock ticks per second. Information in the upper left corner of the screen indicates that node SAMPLE has four CPUs, two of which are active. Because the command line does not include the /CPU qualifier, statistics reflect the combined time that all CPUs spent in each mode.

# MONITOR

## MONITOR MSCP\_SERVER

---

### MONITOR MSCP\_SERVER

The MONITOR MSCP\_SERVER command initiates monitoring of the mass storage control protocol (MSCP) server class.

#### Format

MONITOR MSCP\_SERVER

#### Command Qualifiers

**/qualifier[,...]**

One or more qualifiers as described in the Command Qualifier Descriptions section.

#### Classname Qualifiers

**/ALL**

Specifies that a table of all available statistics (current, average, minimum, and maximum) is to be included in the display and summary output. For summary output, this qualifier is the default for all classes; otherwise, it is the default for all classes except CLUSTER, MODES, PROCESSES, STATES, SYSTEM, and VECTOR.

**/AVERAGE**

Specifies that a bar graph of average statistics is to be included in the display and summary outputs.

**/CURRENT**

Specifies that a bar graph of current statistics is to be included in the display and summary outputs. The /CURRENT qualifier is the default for the CLUSTER, MODES, STATES, SYSTEM, and VECTOR classes.

**/MAXIMUM**

Specifies that a bar graph of maximum statistics is to be included in the display and summary outputs.

**/MINIMUM**

Specifies that a bar graph of minimum statistics is to be included in the display and summary outputs.

#### Description

The MSCP server class consists of the following data items that can be useful in tuning the MSCP server:

---

<b>Data Item</b>	<b>Description</b>
Server I/O Request Rate	The rate at which remote processors request I/O transfers.
Read Request Rate	The rate at which remote processors request Read I/O transfers.



## MONITOR MONITOR MSCP\_SERVER

Data Item	Description
Write Request Rate	The rate at which remote processors request Write I/O transfers.
Extra Fragment Rate	The rate at which the server issues extra fragments. One or more extra fragments are created when, due to buffering constraints, the MSCP server issues multiple I/Os in order to fulfill a single I/O request. For example, if the MSCP server breaks up a 64-block request into 4 fragments of 16 blocks, 3 extra fragments are created.
Fragmented Request Rate	The rate at which fragmented requests occur. A fragmented request is a transfer request that the server fragments due to buffering constraints. For example, one fragmented request occurs when the server splits a 36-block request into 3 fragments of 16 blocks, 16 blocks, and 4 blocks. In this example, the server creates two extra fragments.
Buffer Wait Rate	The rate at which "buffer waits" occur in the server. A buffer wait occurs when a request must wait for MSCP buffer memory.
Request Size Rates	A histogram that displays the rate of requests for various block sizes.

### Example

```
MONITOR> MONITOR MSCP_SERVER
```

```

OpenVMS Monitor Utility
MSCP SERVER STATISTICS
on node GLOBBO
29-APR-2003 09:51:43

```

	CUR	AVE	MIN	MAX
Server I/O Request Rate	0.00	0.71	0.00	6.22
Read Request Rate	0.00	0.54	0.00	6.22
Write Request Rate	0.00	0.16	0.00	6.16
Extra Fragment Rate	0.00	0.00	0.00	0.00
Fragmented Request Rate	0.00	0.00	0.00	0.00
Buffer Wait Rate	0.00	0.00	0.00	0.00
Request Size Rates				
(Blocks)				
1	0.00	0.07	0.00	0.98
2-3	0.00	0.03	0.00	0.65
4-7	0.00	0.03	0.00	0.65
8-15	0.00	0.10	0.00	1.63
16-31	0.00	0.46	0.00	5.51
32-63	0.00	0.00	0.00	0.00
64+	0.00	0.00	0.00	0.00

This example demonstrates use of the MONITOR MSCP\_SERVER command to generate MSCP statistics on node GLOBBO.

# MONITOR MONITOR PAGE

---

## MONITOR PAGE

The MONITOR PAGE command initiates monitoring of the PAGE class.

### Format

MONITOR PAGE

### Command Qualifiers

**/qualifier[,...]**

One or more qualifiers as described in the Command Qualifier Descriptions section.

### Classname Qualifiers

**/ALL**

Specifies that a table of all available statistics (current, average, minimum, and maximum) is to be included in the display and summary output. For summary output, this qualifier is the default for all classes; otherwise, it is the default for all classes except CLUSTER, MODES, PROCESSES, STATES, SYSTEM, and VECTOR.

**/AVERAGE**

Specifies that a bar graph of average statistics is to be included in the display and summary outputs.

**/CURRENT**

Specifies that a bar graph of current statistics is to be included in the display and summary outputs. The /CURRENT qualifier is the default for the CLUSTER, MODES, STATES, SYSTEM, and VECTOR classes.

**/MAXIMUM**

Specifies that a bar graph of maximum statistics is to be included in the display and summary outputs.

**/MINIMUM**

Specifies that a bar graph of minimum statistics is to be included in the display and summary outputs.

### Description

The PAGE class includes the following data items:

Data Item	Description
Page Fault Rate	Rate of page faults for all working sets
Page Read Rate	Rate of pages read from disk as a result of page faults
Page Read I/O Rate	Rate of read I/O operations from disk as a result of page faults
Page Write Rate	Rate at which pages were written to the page file
Page Write I/O Rate	Rate of write I/O operations to the page file

## MONITOR MONITOR PAGE

Data Item	Description
Free List Fault Rate	Rate at which pages were read from the free-page list as a result of page faults
Modified List Fault Rate	Rate of pages read from the modified-page list as a result of page faults
Demand Zero Fault Rate	Rate at which zero-filled pages were allocated as a result of page faults
Global Valid Fault Rate	Rate of page faults for pages that are not in the process's working set, but are in physical memory and are indicated as valid pages in the systemwide global page tables
Writes In Progress Fault Rate	Rate of pages read that were in the process of being written back to disk when faulted
System Fault Rate	Rate of page faults for pages in system space
Free List Size	Number of pages on the free-page list
Modified List Size	Number of pages on the modified-page list

### Example

MONITOR> MONITOR PAGE

```

OpenVMS Monitor Utility
PAGE MANAGEMENT STATISTICS
on node SAMPLE
29-APR-2003 22:22:44

```

	CUR	AVE	MIN	MAX
Page Fault Rate	26.82	18.27	9.66	26.82
Page Read Rate	3.97	2.65	1.33	3.97
Page Read I/O Rate	1.32	0.99	0.66	1.32
Page Write Rate	0.00	0.00	0.00	0.00
Page Write I/O Rate	0.00	0.00	0.00	0.00
Free List Fault Rate	13.90	10.96	8.00	13.90
Modified List Fault Rate	5.62	2.99	0.33	5.62
Demand Zero Fault Rate	4.63	2.65	0.66	4.63
Global Valid Fault Rate	1.32	0.66	0.00	1.32
Wrt In Progress Fault Rate	0.00	0.00	0.00	0.00
System Fault Rate	2.31	1.99	1.66	2.31
Free List Size	3164.00	3176.00	3164.00	3188.00
Modified List Size	155.00	131.00	107.00	155.00

This example shows that the current rate of pages read per read I/O operation is approximately 3 per second (Page Read Rate divided by Page Read I/O Rate). Note that while the page fault rate is currently at the highest point of the monitoring session, the majority of the pages are faulted from memory, not from disk.

# MONITOR MONITOR PROCESSES

---

## MONITOR PROCESSES

The MONITOR PROCESSES command initiates monitoring of the PROCESSES class, which displays information about all processes in the system.

In a multifile summary request, the classes CLUSTER and PROCESSES are ignored. If these classes are the only classes specified on the command line, MONITOR does not recognize them and displays a “no classes specified” error message.

Beginning in OpenVMS Version 8.3, four new qualifiers ( /TOPKERNEL, /TOPEXECUTIVE, /TOPSUPERVISOR, and /TOPUSER) allow you to monitor per-process-based modes usage. These qualifiers are useful in helping to identify the top consumers of the various CPU modes. For example, if the MONITOR MODES command reveals that an excessive amount of supervisor mode is being used, the new MONITOR PROCESSES/TOPSUPERVISOR display reveals which process—and therefore, which user—is responsible.

### Format

MONITOR PROCESSES

### Command Qualifiers

**/qualifier[,...]**

One or more qualifiers as described in the Command Qualifier Descriptions section.

### Classname Qualifiers

**/TOPBIO**

Specifies that a bar graph listing the top buffered I/O users be produced instead of the standard display and summary output. Values are expressed in units of buffered I/Os per second.

**/TOPCPU**

Specifies that a bar graph listing the top CPU time users be produced instead of the standard display and summary output. Values are expressed in units of clock ticks (10 milliseconds) per second.

Prior to OpenVMS Version 7.3, the MONITOR PROCESSES/TOPCPU display showed only a maximum of 8 processes on one screen. In OpenVMS Version 7.3 and later versions, the choice of which one of three screens is displayed is determined by the number of CPUs on the system. (See the examples in this section.)

**/TOPDIO**

Specifies that a bar graph listing the top direct I/O users be produced instead of the standard display and summary output. Values are expressed in units of direct I/Os per second.

**/TOPEXECUTIVE**

Specifies that a bar graph listing the top executive-mode users be produced instead of the standard display and summary output. Values are expressed in clock ticks (10 ms) per second.

**/TOPFAULT**

Specifies that a bar graph listing the top page-faulting processes be produced instead of the standard display and summary output. Values are expressed in number of page faults per second.

**/TOPKERNEL**

Specifies that a bar graph listing the top kernel-mode users be produced instead of the standard display and summary output. Values are expressed in clock ticks (10 ms\_ per second).

**/TOPSUPERVISOR**

Specifies that a bar graph listing the top supervisor-mode users be produced instead of the standard display and summary output. Values are expressed in clock ticks (10 ms) per second.

**/TOPUSER**

Specifies that a bar graph listing the top user-mode users be produced instead of the standard display and summary output. Values are expressed in clock ticks (10 ms\_ per second).

**Description**

As illustrated in the examples, the PROCESSES display (and summary) formats are different from those of all other classes. The PROCESSES display provides the following information:

<b>Data Item</b>	<b>Description</b>
PID	Process identifier as assigned by the system, in hexadecimal
STATE	Process's scheduler state (see the description of the MONITOR STATES command for an explanation and a tabular summary of the STATES codes)
PRI	Current (as opposed to base) priority of the process
NAME	Process name
PAGES	Number of shareable pages and total number of pages currently in use by the process
DIOCNT	Cumulative direct I/O operations performed by the process since its creation; not displayed if the process is swapped out
FAULTS	Cumulative page faults since the process was created; not displayed if the process is swapped out
CPU TIME	Cumulative CPU time used by the process since its creation, in the format hours:minutes:seconds; not displayed if the process is swapped out

The top corners of the display contain the number of processes in the system and the time in days, hours, minutes, and seconds since the system was last booted. Processes that are swapped out are so noted.

If more processes are in the system than can be displayed on the terminal screen at once, the display consists of multiple screens. Screens are presented one at a time at intervals specified with the /VIEWING\_TIME qualifier. The five /TOP bar graph displays provide the PID and process name of each of the top eight users.

## MONITOR MONITOR PROCESSES

As with the other bar graph displays, examples in the displays of top users are rounded to the nearest whole number. Up to 16 processes with nonzero values are displayed. To be eligible for inclusion in the list of top users, a process must be present and swapped in at the beginning and end of the display interval. This eligibility requirement also applies to the beginning and ending of the entire period covered by a summary.

Note that only one of the displays of top users or the regular PROCESSES display can be selected in a single MONITOR request.

### Examples

1. MONITOR> MONITOR/INPUT=PROCS.DAT/INTERVAL=6 PROCESSES

```
Process Count: 20          OpenVMS Monitor Utility          Uptime:  1 23:26:10
                          PROCESSES
                          on node SAMPLE
                          29-APR-2003 12:39:09

   PID  STATE PRI  NAME          PAGES    DIOCNT  FAULTS  CPU TIME
00000081 HIB   16  SWAPPER          0/0         0        0 00:00:15.8
00000102 LEFO   4  SAMPLE1001      87/232     SWAPPED OUT
00000103 COM   4  SAMPLE1101     16/100     7127    51298 00:05:11.0
00000084 HIB   8  ERRFMT         64/174     2750     125 00:00:43.9
00000086 LEF   8  OPCOM          73/272     283      178 00:00:07.7
00000087 HIB   9  JOB CONTROL    57/293     707     167 00:00:10.5
00000088 HIB   8  CONFIGURE     43/205      22     123 00:00:00.6
0000008A HIB   6  SYMBIONT_0001  5/56        50     617 00:03:15.1
0000008B HIB   8  JNLACP        75/580    15149    4922 00:21:51.1
0000008C HIB   8  NETACP        5/954      11    1057 00:25:06.8
0000008D HIB   5  EVL           7/56       44   34384 00:00:20.5
0000008E HIB   9  REMACP        5/54       13     107 00:00:01.3
00000112 COM   4  SAMPLE1601    45/111    13131   39992 00:06:39.1
0000011E CUR   9  SMITH         89/298     138     830 00:00:07.1
```

This example illustrates a PROCESSES display generated from the input file PROCS.DAT. One line is displayed for each process in the system. This display shows current values only—average, minimum, and maximum statistics are not available. Also for swapped-out processes, the words SWAPPED OUT replace the three rightmost items, because those items are not available for swapped-out processes. Because this example is a playback request, the system uptime displayed is that of the system at the time the MONITOR data was recorded.

Nondisplayable characters in process names are represented by periods.

# MONITOR MONITOR PROCESSES

2. MONITOR> MONITOR/INPUT=PROCS.DAT PROCESSES/TOPDIO

OpenVMS Monitor Utility  
TOP DIRECT I/O RATE PROCESSES  
on node SAMPLE  
29-APR-2003 16:13:38

			0	25	50	75	100
			+ - - - - +	+ - - - - +	+ - - - - +	+ - - - - +	+ - - - - +
000000C7	SAMPLE0901	25	*****				
00000112	SAMPLE1601	17	*****				
00000102	SAMPLE1001	14	*****				
00000103	SAMPLE1101	12	****				
00000080	NULL	12	****				
0000011E	SMITH	4	*				
0000008C	NETACP	1					
			+ - - - - +	+ - - - - +	+ - - - - +	+ - - - - +	+ - - - - +

This example shows that the process SAMPLE0901, with a rate of 25 per second, was the top consumer of direct I/Os during the most recent interval between displays.

3. MONITOR> MONITOR PROCESSES/TOPCPU

OpenVMS Monitor Utility  
TOP CPU TIME PROCESSES  
on node BRS004  
5-JUN-2003 10:47:49.21

			0	25	50	75	100
			+ - - - - +	+ - - - - +	+ - - - - +	+ - - - - +	+ - - - - +
00000121	BATCH_36	6	**				
0000012A	BATCH_45	6	**				
00000117	BATCH_26	6	**				
0000011D	BATCH_32	5	**				
0000011A	BATCH_29	5	**				
0000012B	BATCH_46	5	**				
00000125	BATCH_40	5	**				
0000011F	BATCH_34	5	**				
			+ - - - - +	+ - - - - +	+ - - - - +	+ - - - - +	+ - - - - +

# MONITOR MONITOR PROCESSES

This example shows a MONITOR PROCESSES/TOPCPU screen display on a single CPU system.

4. MONITOR> MONITOR PROCESSES/TOPCPU

```
OpenVMS Monitor Utility
TOP CPU TIME PROCESSES
on node BRS012
5-JUN-2003 10:48:39.38

          0          25          50          75          100
          + - - - + - - - + - - - + - - - +
0000012B BATCH_46      7  **
00000128 BATCH_43      6  **
0000012A BATCH_45      5  **
00000125 BATCH_40      5  **
00000123 BATCH_38      5  **
00000121 BATCH_36      5  **
00000129 BATCH_44      5  **
0000011F BATCH_34      5  **
0000011E BATCH_33      5  **
0000011D BATCH_32      5  **
00000117 BATCH_26      5  **
00000127 BATCH_42      5  **
00000120 BATCH_35      5  **
0000011B BATCH_30      5  **
00000119 BATCH_28      5  **
```

This example shows a MONITOR PROCESSES/TOPCPU screen display on a 12-CPU system.

5. MONITOR> MONITOR PROCESSES/TOPCPU

```
OpenVMS Monitor Utility
TOP CPU TIME PROCESSES
on node BRS016
5-JUN-2003 10:51:10.89
```



# MONITOR MONITOR PROCESSES

		0	25	50	75	100
		+ - - - - +	+ - - - - +	+ - - - - +	+ - - - - +	+ - - - - +
00000127	BATCH_42	6				**
00000125	BATCH_40	6				**
00000124	BATCH_39	5				**
00000118	BATCH_27	5				**
00000129	BATCH_44	5				**
00000122	BATCH_37	5				**
00000120	BATCH_35	5				**
0000011F	BATCH_34	5				**
0000011D	BATCH_32	5				**
0000011C	BATCH_31	5				**
00000119	BATCH_28	5				**
00000128	BATCH_43	5				**
00000123	BATCH_38	5				**
0000011B	BATCH_30	4				*
0000012B	BATCH_46	4				*
00000126	BATCH_41	4				*

This example shows a MONITOR PROCESSES/TOPCPU screen display on a 16-CPU system.

## 6. MONITOR> MONITOR PROCESSES/TOPSUPERVISOR

OpenVMS Monitor Utility  
TOP SUPERVISOR MODE PROCESSES  
on node QUEBIT  
7-DEC-2005 14:04:24.19

		0	25	50	75	100
		+ - - - - +	+ - - - - +	+ - - - - +	+ - - - - +	+ - - - - +
74E000AD	BATCH_3	5				**
74E000AC	BATCH_2	4				*
74E000AA	BATCH_1	3				*
74E000AB	_RTA3:	3				*

+ - - - - + - - - - + - - - - + - - - - +

The command in this example displays a bar graph that shows the 16 processes that are top consumers of CPU time in supervisor mode. Values are expressed in clock ticks (10 ms) per second.

## MONITOR MONITOR RLOCK

---

### MONITOR RLOCK

The MONITOR RLOCK command initiates monitoring of the RLOCK (dynamic lock remastering) statistics class.

#### Format

MONITOR RLOCK

#### Command Qualifiers

**/qualifier[,...]**

One or more qualifiers as described in the Command Qualifier Descriptions section.

#### Classname Qualifiers

**/ALL**

Specifies that a table of all available statistics (current, average, minimum and maximum) is to be included in the display and summary outputs. For summary output, this qualifier is the default for all classes; otherwise, it is the default for all classes except CLUSTER, MODES, PROCESSES, STATES, SYSTEM, and VECTOR.

**/AVERAGE**

Specifies that a bar graph of average statistics is to be included in the display and summary outputs.

**/CURRENT**

Specifies that a bar graph of current statistics is to be included in the display and summary outputs. The /CURRENT qualifier is the default for the CLUSTER, MODES, STATES, SYSTEM, and VECTOR classes.

**/MAXIMUM**

Specifies that a bar graph of maximum statistics is to be included in the display and summary outputs.

**/MINIMUM**

Specifies that a bar graph of minimum statistics is to be included in the display and summary outputs.

#### Description

You can use the RLOCK class to monitor the dynamic lock remastering statistics of a node. Because local locking operations are less costly than remote operations, lock trees are moved from node to node to improve performance. A lock tree might be moved for any of the following reasons:

- Another node in the cluster is much more active on the tree than the current master.
- A node with a higher LOCKDIRWT enqueues a lock to a resource that a node with a lower LOCKDIRWT masters.
- Only one node in the cluster has locks on this resource and should, therefore, become the master.

## MONITOR MONITOR RLOCK

The class RLOCK consists of the following data items, which are displayed as the rate of occurrences per second:

| Data Item                 | Description   |
|---------------------------|---|
| Lock Tree Outbound Rate   | Rate at which lock trees are moved from this node.  |
| Higher Activity           | Rate for trees moved due to higher locking activity on another node in the cluster.                               |
| Higher LOCKDIRWT          | Rate at which trees are moved to a node with a higher value of the SYSGEN parameter LOCKDIRWT.                    |
| Sole Interest             | Rate at which trees are moved to another node because that node is the only one with locks remaining on the tree. |
| Remaster Msg Send Rate    | Rate at which remaster messages are sent from this node.  |
| Lock Tree Inbound Rate    | Rate at which trees are moved to this node.   |
| Remaster Msg Receive Rate | Rate at which remaster messages are received on this node.  |

### Example

```
MONITOR> MONITOR RLOCK
```

```
          DYNAMIC LOCK REMASTERING STATISTICS
                on node JYGAL2
          30-OCT-2003 12:19:55.27
```

|                           | CUR  | AVE  | MIN  | MAX  |
|---------------------------|------|------|------|------|
| Lock Tree Outbound Rate   | 0.33 | 0.02 | 0.00 | 0.33 |
| (Higher Activity)         | 0.33 | 0.02 | 0.00 | 0.33 |
| (Higher LCKDIRWT)         | 0.00 | 0.00 | 0.00 | 0.00 |
| (Sole Interest)           | 0.00 | 0.00 | 0.00 | 0.00 |
| Remaster Msg Send Rate    | 2.66 | 0.25 | 0.00 | 2.66 |
| Lock Tree Inbound Rate    | 0.00 | 0.01 | 0.00 | 0.33 |
| Remaster Msg Receive Rate | 0.00 | 0.09 | 0.00 | 1.66 |

In this example, the outbound numbers are quite low; in most cases, these numbers are never very large. Remastering is attempted only once every 8 seconds; then a maximum of 5 trees are processed at once. The exception is during orderly shutdown, when the system attempts to force all trees off the node shutting down.

# MONITOR MONITOR RMS

---

## MONITOR RMS

The MONITOR RMS command initiates monitoring of the OpenVMS Record Management Services (OpenVMS RMS) statistics class for a specific file.

### Format

MONITOR RMS

### Command Qualifiers

**/qualifier[,...]**

One or more qualifiers as described in the Command Qualifier Descriptions section.

### Classname Qualifiers

**/ALL**

Specifies that a table of all available statistics (current, average, minimum, and maximum) is to be included in the display and summary output. For summary output, this qualifier is the default for all classes; otherwise, it is the default for all classes except CLUSTER, MODES, PROCESSES, STATES, SYSTEM, and VECTOR.

**/AVERAGE**

Specifies that a bar graph of average statistics is to be included in the display and summary outputs.

**/CURRENT**

Specifies that a bar graph of current statistics is to be included in the display and summary outputs. The /CURRENT qualifier is the default for the CLUSTER, MODES, STATES, SYSTEM, and VECTOR classes.

**/FILE=(file-name[,...])**

Specifies a list of one or more files to which the MONITOR RMS command applies. If you include a node name as part of the file specification, MONITOR ignores the node name. Use the /NODE command qualifier to select specific nodes for MONITOR RMS requests. If you use the /NODE command qualifier to specify multiple nodes, the file must exist on all specified nodes. You can list up to 5,000 files. Do not specify wildcard characters.

**/ITEM=(keyword[,...])**

Selects one or more data items for inclusion in display and summary outputs. If you specify two or more keywords, enclose them in parentheses, and separate them with commas. When the /ITEM qualifier is omitted, the default is /ITEM=OPERATIONS.

The following table describes /ITEM qualifier keywords:

| Keyword    | Description   |
|------------|---|
| OPERATIONS | Specifies that RMS basic operations statistics are displayed for the selected file. |

| Keyword    | Description  |
|------------|--|
| DATA_RATES | Specifies that RMS data rate statistics are displayed for the selected file. |
| LOCKING    | Specifies that RMS locking statistics are displayed for the selected file.   |
| CACHING    | Specifies that RMS caching statistics are displayed for the selected file.   |

**/MAXIMUM**

Specifies that a bar graph of maximum statistics is to be included in the display and summary outputs.

**/MINIMUM**

Specifies that a bar graph of minimum statistics is to be included in the display and summary outputs.

**Description**

When you enter the MONITOR RMS command, you must use the /FILE qualifier to specify an input file. MONITOR displays RMS statistics for the input file that you specify. MONITOR displays statistics only for the input file if statistics are enabled for the file, and the file is open. For information about enabling statistics for a file, see the SET FILE command in the *HP OpenVMS DCL Dictionary* and the *OpenVMS Record Management Services Reference Manual*.

The MONITOR RMS command generates RMS statistics of the following types:

- Basic operations (produced by specifying the OPERATIONS item)
- Data rates per operation (produced by specifying the DATA\_RATES item)
- File locking (produced by specifying the LOCKING item)
- Caching (produced by specifying the CACHING item)

**Basic operations** statistics consist of the following data items:

- Sequential \$Get Call Rate
- Keyed \$Get Call Rate
- RFA \$Get Call Rate
- Sequential \$Find Call Rate
- Keyed \$Find Call Rate
- RFA \$Find Call Rate
- Sequential \$Put Call Rate
- Keyed \$Put Call Rate
- \$Read Call Rate
- \$Write Call Rate
- \$Update Call Rate
- \$Delete Call Rate
- \$Truncate Call Rate
- \$Extend Call Rate
- \$Flush Call Rate

**Data rate** statistics consist of the following data items:

- Total \$GET Call Rate
- Bytes per \$GET
- Total \$PUT Call Rate
- Bytes Per \$PUT

## MONITOR MONITOR RMS

Total \$UPDATE Call Rate  
Bytes per \$UPDATE  
\$READ Call Rate  
Bytes per \$READ  
\$WRITE Call Rate  
Bytes per \$WRITE  
\$TRUNCATE Call Rate  
Blocks per \$TRUNCATE  
\$EXTEND Call Rate  
Blocks per \$EXTEND

**File locking** statistics consist of the following data items:

New ENQ Rate  
DEQ Rate  
Converted ENQ Rate  
Blocking AST Rate  
Bucket Split Rate  
Multi-Bucket Split Rate

**Caching** statistics consist of the following data items:

Local Cache Hit Percent  
Local Cache Attempt Rate  
Global Cache Hit Percent  
Global Cache Attempt Rate  
Global Buffer Read I/O Rate  
Global Buffer Write I/O Rate  
Local Buffer Read I/O Rate  
Local Buffer Write I/O Rate

---

**Note**

---

Values produced by the MONITOR RMS command do not include I/Os generated by the recovery mechanisms of RMS Journaling.

---

For more information about OpenVMS RMS, OpenVMS RMS services, and file applications, see the *OpenVMS Record Management Services Reference Manual*, *HP OpenVMS System Services Reference Manual*, and the *Guide to OpenVMS File Applications*.

**Example**

MONITOR> MONITOR RMS /ITEM=OPERATIONS /FILE=SYS\$COMMON:[SYSEXE]SYSUAF.DAT

```

                                OpenVMS Monitor Utility
                                RMS FILE OPERATIONS
                                on node SAMPLE
                                29-APR-2003 11:03:06
(Index) _$254$DUA213:[SYS0.SYSEXE]SYSUAF.DAT;2
Active Streams:  17          CUR          AVE          MIN          MAX
$GET Call Rate  (Seq)          0.00         0.00         0.00         0.00
                 (Key)          4.30         2.15         0.00         6.76
                 (RFA)          0.00         0.00         0.00         0.00
$FIND Call Rate (Seq)          0.00         0.00         0.00         0.00
                 (Key)          0.00         0.00         0.00         0.00
                 (RFA)          0.00         0.00         0.00         0.00
$PUT Call Rate  (Seq)          0.00         0.00         0.00         0.00
                 (Key)          0.20         0.14         0.00         0.30
$READ Call Rate          0.00         0.00         0.00         0.00
$WRITE Call Rate         0.00         0.00         0.00         0.00
$UPDATE Call Rate        0.00         0.00         0.00         0.00
$DELETE Call Rate        0.00         0.00         0.00         0.00
$TRUNCATE Call Rate      0.00         0.00         0.00         0.00
$EXTEND Call Rate        0.00         0.00         0.00         0.00
$FLUSH Call Rate         0.00         0.00         0.00         0.00

```

This example demonstrates the use of the MONITOR RMS command to generate basic operations statistics for the file SYSUAF.DAT.

# MONITOR

## MONITOR SCS

---

### MONITOR SCS

The MONITOR SCS command initiates monitoring of the System Communications Services (SCS) class.

#### Format

MONITOR SCS

#### Command Qualifiers

**/qualifier[,...]**

One or more qualifiers as described in the Command Qualifier Descriptions section.

#### Classname Qualifiers

**/ALL**

Specifies that a table of all available statistics (current, average, minimum, and maximum) is to be included in the display and summary output. For summary output, this qualifier is the default for all classes; otherwise, it is the default for all classes except CLUSTER, MODES, PROCESSES, STATES, SYSTEM, and VECTOR.

**/AVERAGE**

Specifies that a bar graph of average statistics is to be included in the display and summary outputs.

**/CURRENT**

Specifies that a bar graph of current statistics is to be included in the display and summary outputs. The /CURRENT qualifier is the default for the CLUSTER, MODES, STATES, SYSTEM, and VECTOR classes.

**/ITEM=(keyword[,...])**

Selects one or more data items for inclusion in display and summary outputs. If you specify two or more keywords, enclose them in parentheses, and separate them with commas. When the /ITEM qualifier is omitted, the default is /ITEM=KB\_MAP.

The following table describes /ITEM qualifier keywords:

| Keyword           | Description   |
|-------------------|---|
| ALL               | Specifies that statistics on all data items collected for the disks are displayed on successive screens.            |
| BUFFER_DESCRIPTOR | Specifies that statistics on the queued-for-buffer-descriptor (on the local node) rate are displayed for each node. |
| D_DISCARD         | Specifies that datagram discard rate statistics are displayed for each node.  |
| D_RECEIVE         | Specifies that datagram receive rate statistics are displayed for each node.  |



| <b>Keyword</b> | <b>Description</b>   |
|----------------|--|
| D_SEND         | Specifies that datagram send rate statistics are displayed for each node.                              |
| KB_MAP         | Specifies that kilobyte map rate statistics are displayed for each node.                               |
| KB_REQUEST     | Specifies that kilobyte request (via request datas) rate statistics are displayed for each node.       |
| KB_SEND        | Specifies that kilobyte send (via send datas) rate statistics are displayed for each node.             |
| M_RECEIVE      | Specifies that message receive rate statistics are displayed for each node.                            |
| M_SEND         | Specifies that message send rate statistics are displayed for each node.                               |
| REQUEST_DATA   | Specifies that request data (initiated on the local node) rate statistics are displayed for each node. |
| SEND_CREDIT    | Specifies that queued-for-send-credit (on the local node) rate statistics are displayed for each node. |
| SEND_DATA      | Specifies that send data (initiated on the local node) rate statistics are displayed for each node.    |

**/MAXIMUM**

Specifies that a bar graph of maximum statistics is to be included in the display and summary outputs.

**/MINIMUM**

Specifies that a bar graph of minimum statistics is to be included in the display and summary outputs.

**/PERCENT**

**/NOPERCENT (default)**

Controls whether statistics are expressed as percent values in display and summary outputs. The /PERCENT qualifier is applicable only to the DISK, MODES, SCS, and STATES classes.

**Description**

The SCS class is a component class. Data items for this class are collected for each node in the cluster. The SCS class consists of the following data items:

| <b>Data Item</b>      | <b>Description</b>                                      |
|-----------------------|---|
| Datagram Send Rate    | Rate at which datagrams are sent to another node.       |
| Datagram Receive Rate | Rate at which datagrams are received from another node. |
| Datagram Discard Rate | Rate at which datagrams are discarded.                  |

## MONITOR MONITOR SCS

| Data Item                     | Description  |
|-------------------------------|--|
| Message Send Rate             | Rate at which sequenced messages are sent to another node. Sequenced messages are exchanged between nodes to communicate with mass storage control protocol (MSCP) disks and the lock manager.   |
| Message Receive Rate          | Rate at which sequenced messages are received from another node. Sequenced messages are exchanged between nodes to communicate with MSCP disks and the lock manager.   |
| Send Data Rate                | Rate at which block send datas are initiated on the local node.  |
| Kbytes Send Rate              | Rate at which kilobytes are sent, as a result of send datas initiated on the local node.   |
| Request Data Rate             | Rate at which request datas are initiated on the local node.   |
| Kbytes Request Rate           | Rate at which kilobytes are received, as a result of request datas initiated on the local node.  |
| Kbytes Map Rate               | Rate at which kilobytes are mapped for block transfers. This is a rough measure of the data transfer rate between the local node and a remote node. Before any transfer can take place, a buffer must be mapped. The size of the accumulated buffers that were mapped is displayed by the Kbytes Map Rate. If request datas or send datas are initiated on the local or a remote node, then the Kbytes Map Rate reflects the number of kilobytes actually transferred between the two nodes. |
| Send Credit Queued Rate       | Rate at which connections are queued for a send credit. A connection is queued for a send credit whenever all of the buffers that were allocated by the remote node have been used.  |
| Buffer Descriptor Queued Rate | Rate at which connections are queued for a buffer descriptor. A connection is queued for a buffer descriptor whenever all of the buffer descriptors have been allocated by the local node. You can increase the number of buffer descriptors allocated on the local system by adjusting the system parameter SCSBUFFCNT.   |

**Example**

MONITOR> MONITOR SCS

```
OpenVMS Monitor Utility
SCS STATISTICS
on node CURLEY
29-APR-2003 10:21:46

Kbytes Map Rate          CUR      AVE      MIN      MAX
CURLEY                   0.00    0.00    0.00    0.00
MOE                      0.00    0.00    0.00    0.00
LARRY                    0.00    0.00    0.00    0.00
SHEMP                    5.64    3.81    1.98    5.64
```

The command in this example requests that kilobyte map rate statistics collected for SCS be displayed for each node in the cluster. The display shows block transfer map activity between the node CURLEY and the hierarchical storage controller (HSC) SHEMP. Note that each node in the cluster is identified by its SCS node name.

# MONITOR

## MONITOR STATES

---

### MONITOR STATES

The MONITOR STATES command initiates monitoring of the PROCESS STATES class, which shows the number of processes in each of the 14 scheduler states.

#### Format

MONITOR STATES

#### Command Qualifiers

**/qualifier[,...]**

One or more qualifiers as described in the Command Qualifier Descriptions section.

#### Classname Qualifiers

**/ALL**

Specifies that a table of all available statistics (current, average, minimum, and maximum) is to be included in the display and summary output. For summary output, this qualifier is the default for all classes; otherwise, it is the default for all classes except CLUSTER, MODES, PROCESSES, STATES, SYSTEM, and VECTOR.

**/AVERAGE**

Specifies that a bar graph of average statistics is to be included in the display and summary outputs.

**/CURRENT**

Specifies that a bar graph of current statistics is to be included in the display and summary outputs. The /CURRENT qualifier is the default for the CLUSTER, MODES, STATES, SYSTEM, and VECTOR classes.

**/MAXIMUM**

Specifies that a bar graph of maximum statistics is to be included in the display and summary outputs.

**/MINIMUM**

Specifies that a bar graph of minimum statistics is to be included in the display and summary outputs.

**/PERCENT**

**/NOPERCENT (default)**

Controls whether statistics are expressed as percent values in display and summary outputs. The /PERCENT qualifier is applicable only to the DISK, MODES, SCS, and STATES class names.

## Description

The STATES class shows the number of processes in each of the 14 scheduler states. The following table describes these scheduler states:

| Scheduler State                             | Description   |       |                 |       |                            |       |  |       |   |       |                         |       |                               |       |                |       |                       |       |               |       |              |       |                           |       |                          |       |                         |       |                      |       |                |       |           |       |                                     |       |                 |       |                 |
|---|---|-------|-----------------|-------|----------------------------|-------|--|-------|---|-------|-------------------------|-------|-------------------------------|-------|----------------|-------|-----------------------|-------|---------------|-------|--------------|-------|---------------------------|-------|--------------------------|-------|-------------------------|-------|----------------------|-------|----------------|-------|-----------|-------|-------------------------------------|-------|-----------------|-------|-----------------|
| Collided Page Wait (COLPG)                  | Waiting for a faulted page in transition.   |       |                 |       |                            |       |  |       |   |       |                         |       |                               |       |                |       |                       |       |               |       |              |       |                           |       |                          |       |                         |       |                      |       |                |       |           |       |                                     |       |                 |       |                 |
| Mutex & Miscellaneous Resource Wait (MWAIT) | Waiting for the availability of a mutual exclusion semaphore or a dynamic resource. The following table contains a summary of Mutex and Miscellaneous Resource Wait states and identifying codes, as they appear in the PROCESSES class display:  |       |                 |       |                            |       |  |       |   |       |                         |       |                               |       |                |       |                       |       |               |       |              |       |                           |       |                          |       |                         |       |                      |       |                |       |           |       |                                     |       |                 |       |                 |
|   | <table border="1"> <thead> <tr> <th>MWAIT</th> <th>Reason for Wait</th> </tr> </thead> <tbody> <tr> <td>MUTEX</td> <td>Mutual exclusion semaphore</td> </tr> <tr> <td>RWAST</td> <td>AST wait (wait for system or special kernel AST)</td> </tr> <tr> <td>RWBRK</td> <td>Breakthrough (wait for broadcast message)</td> </tr> <tr> <td>RWCAP</td> <td>CPU capability required</td> </tr> <tr> <td>RWCLU</td> <td>Cluster state transition wait</td> </tr> <tr> <td>RWCSV</td> <td>Cluster server</td> </tr> <tr> <td>RWIMG</td> <td>Image activation lock</td> </tr> <tr> <td>RWLCK</td> <td>Lock database</td> </tr> <tr> <td>RWMBX</td> <td>Mailbox full</td> </tr> <tr> <td>RWMPB</td> <td>Modified page writer busy</td> </tr> <tr> <td>RWMPE</td> <td>Modified page list empty</td> </tr> <tr> <td>RWNPG</td> <td>Nonpaged dynamic memory</td> </tr> <tr> <td>RWPAG</td> <td>Paged dynamic memory</td> </tr> <tr> <td>RWPGF</td> <td>Page file full</td> </tr> <tr> <td>RWQUO</td> <td>Job quota</td> </tr> <tr> <td>RWSCS</td> <td>System Communications Services wait</td> </tr> <tr> <td>RWSNP</td> <td>System snapshot</td> </tr> <tr> <td>RWSWP</td> <td>Swap file space</td> </tr> </tbody> </table> | MWAIT | Reason for Wait | MUTEX | Mutual exclusion semaphore | RWAST | AST wait (wait for system or special kernel AST) | RWBRK | Breakthrough (wait for broadcast message) | RWCAP | CPU capability required | RWCLU | Cluster state transition wait | RWCSV | Cluster server | RWIMG | Image activation lock | RWLCK | Lock database | RWMBX | Mailbox full | RWMPB | Modified page writer busy | RWMPE | Modified page list empty | RWNPG | Nonpaged dynamic memory | RWPAG | Paged dynamic memory | RWPGF | Page file full | RWQUO | Job quota | RWSCS | System Communications Services wait | RWSNP | System snapshot | RWSWP | Swap file space |
| MWAIT                                       | Reason for Wait   |       |                 |       |                            |       |  |       |   |       |                         |       |                               |       |                |       |                       |       |               |       |              |       |                           |       |                          |       |                         |       |                      |       |                |       |           |       |                                     |       |                 |       |                 |
| MUTEX                                       | Mutual exclusion semaphore  |       |                 |       |                            |       |  |       |   |       |                         |       |                               |       |                |       |                       |       |               |       |              |       |                           |       |                          |       |                         |       |                      |       |                |       |           |       |                                     |       |                 |       |                 |
| RWAST                                       | AST wait (wait for system or special kernel AST)  |       |                 |       |                            |       |  |       |   |       |                         |       |                               |       |                |       |                       |       |               |       |              |       |                           |       |                          |       |                         |       |                      |       |                |       |           |       |                                     |       |                 |       |                 |
| RWBRK                                       | Breakthrough (wait for broadcast message)   |       |                 |       |                            |       |  |       |   |       |                         |       |                               |       |                |       |                       |       |               |       |              |       |                           |       |                          |       |                         |       |                      |       |                |       |           |       |                                     |       |                 |       |                 |
| RWCAP                                       | CPU capability required   |       |                 |       |                            |       |  |       |   |       |                         |       |                               |       |                |       |                       |       |               |       |              |       |                           |       |                          |       |                         |       |                      |       |                |       |           |       |                                     |       |                 |       |                 |
| RWCLU                                       | Cluster state transition wait   |       |                 |       |                            |       |  |       |   |       |                         |       |                               |       |                |       |                       |       |               |       |              |       |                           |       |                          |       |                         |       |                      |       |                |       |           |       |                                     |       |                 |       |                 |
| RWCSV                                       | Cluster server  |       |                 |       |                            |       |  |       |   |       |                         |       |                               |       |                |       |                       |       |               |       |              |       |                           |       |                          |       |                         |       |                      |       |                |       |           |       |                                     |       |                 |       |                 |
| RWIMG                                       | Image activation lock   |       |                 |       |                            |       |  |       |   |       |                         |       |                               |       |                |       |                       |       |               |       |              |       |                           |       |                          |       |                         |       |                      |       |                |       |           |       |                                     |       |                 |       |                 |
| RWLCK                                       | Lock database   |       |                 |       |                            |       |  |       |   |       |                         |       |                               |       |                |       |                       |       |               |       |              |       |                           |       |                          |       |                         |       |                      |       |                |       |           |       |                                     |       |                 |       |                 |
| RWMBX                                       | Mailbox full  |       |                 |       |                            |       |  |       |   |       |                         |       |                               |       |                |       |                       |       |               |       |              |       |                           |       |                          |       |                         |       |                      |       |                |       |           |       |                                     |       |                 |       |                 |
| RWMPB                                       | Modified page writer busy   |       |                 |       |                            |       |  |       |   |       |                         |       |                               |       |                |       |                       |       |               |       |              |       |                           |       |                          |       |                         |       |                      |       |                |       |           |       |                                     |       |                 |       |                 |
| RWMPE                                       | Modified page list empty  |       |                 |       |                            |       |  |       |   |       |                         |       |                               |       |                |       |                       |       |               |       |              |       |                           |       |                          |       |                         |       |                      |       |                |       |           |       |                                     |       |                 |       |                 |
| RWNPG                                       | Nonpaged dynamic memory   |       |                 |       |                            |       |  |       |   |       |                         |       |                               |       |                |       |                       |       |               |       |              |       |                           |       |                          |       |                         |       |                      |       |                |       |           |       |                                     |       |                 |       |                 |
| RWPAG                                       | Paged dynamic memory  |       |                 |       |                            |       |  |       |   |       |                         |       |                               |       |                |       |                       |       |               |       |              |       |                           |       |                          |       |                         |       |                      |       |                |       |           |       |                                     |       |                 |       |                 |
| RWPGF                                       | Page file full  |       |                 |       |                            |       |  |       |   |       |                         |       |                               |       |                |       |                       |       |               |       |              |       |                           |       |                          |       |                         |       |                      |       |                |       |           |       |                                     |       |                 |       |                 |
| RWQUO                                       | Job quota   |       |                 |       |                            |       |  |       |   |       |                         |       |                               |       |                |       |                       |       |               |       |              |       |                           |       |                          |       |                         |       |                      |       |                |       |           |       |                                     |       |                 |       |                 |
| RWSCS                                       | System Communications Services wait   |       |                 |       |                            |       |  |       |   |       |                         |       |                               |       |                |       |                       |       |               |       |              |       |                           |       |                          |       |                         |       |                      |       |                |       |           |       |                                     |       |                 |       |                 |
| RWSNP                                       | System snapshot   |       |                 |       |                            |       |  |       |   |       |                         |       |                               |       |                |       |                       |       |               |       |              |       |                           |       |                          |       |                         |       |                      |       |                |       |           |       |                                     |       |                 |       |                 |
| RWSWP                                       | Swap file space   |       |                 |       |                            |       |  |       |   |       |                         |       |                               |       |                |       |                       |       |               |       |              |       |                           |       |                          |       |                         |       |                      |       |                |       |           |       |                                     |       |                 |       |                 |
| Common Event Flag Wait (CEF)                | Waiting for a combination of event flags to be set in a common event block.   |       |                 |       |                            |       |  |       |   |       |                         |       |                               |       |                |       |                       |       |               |       |              |       |                           |       |                          |       |                         |       |                      |       |                |       |           |       |                                     |       |                 |       |                 |
| Page Fault Wait (PFW)                       | Waiting for a page to be read as a result of a page fault; resident processes.  |       |                 |       |                            |       |  |       |   |       |                         |       |                               |       |                |       |                       |       |               |       |              |       |                           |       |                          |       |                         |       |                      |       |                |       |           |       |                                     |       |                 |       |                 |
| Local Event Flag Wait (LEF)                 | Waiting for one or more local event flags to be posted; resident processes.   |       |                 |       |                            |       |  |       |   |       |                         |       |                               |       |                |       |                       |       |               |       |              |       |                           |       |                          |       |                         |       |                      |       |                |       |           |       |                                     |       |                 |       |                 |
| Local Event Flag (Outswapped) (LEFO)        | Waiting for one or more local event flags to be posted; outswapped processes.   |       |                 |       |                            |       |  |       |   |       |                         |       |                               |       |                |       |                       |       |               |       |              |       |                           |       |                          |       |                         |       |                      |       |                |       |           |       |                                     |       |                 |       |                 |

# MONITOR

## MONITOR STATES

| Scheduler State                | Description   |
|--------------------------------|---|
| Hibernate (HIB)                | Hibernating, or process has executed a hibernate request; resident processes.   |
| Hibernate (Outswapped) (HIBO)  | Hibernating, or process has executed a hibernate request; outswapped processes. |
| Suspended (SUSP)               | Process has executed a suspend request; resident processes.                     |
| Suspended (Outswapped) (SUSPO) | Process has executed a suspend request; outswapped processes.                   |
| Free Page Wait (FPW)           | Waiting for a free page of memory.  |
| Compute (COM)                  | Ready to use the processor; resident processes.                                 |
| Compute (Outswapped) (COMO)    | Ready to use the processor; outswapped processes.                               |
| Current Process (CUR)          | Using the processor.  |

The data items can also be displayed as percentages of all processes.

Note that the Current Process is always the process running MONITOR, because MONITOR is running when each measurement is made.

For performance reasons, MONITOR does not synchronize the scanning of process state data structures with operating system use of those structures. It is therefore possible that MONITOR will display certain anomalous state indications.

### Example

```
$ MONITOR/INPUT/SUMMARY/NODISPLAY -
  $/BEGINNING=29-APR-2003:13:00 -
  $/ENDING=29-APR-2003:14:00 STATES/PERCENT/ALL
  § TYPE MONITOR.SUM
```

| OpenVMS Monitor Utility    |             |             |          |      |
|----------------------------|-------------|-------------|----------|------|
| PROCESS STATES (%)         |             |             |          |      |
| on node SAMPLE             |             |             |          |      |
| SUMMARY                    |             |             |          |      |
|                            | From:       | 29-APR-2003 | 13:00:00 |      |
|                            | To:         | 29-APR-2003 | 14:00:00 |      |
|                            | CUR%        | AVE%        | MIN%     | MAX% |
| Collided Page Wait         | 0.0         | 0.0         | 0.0      | 0.0  |
| Mutex & Misc Resource Wait | 0.0         | 0.0         | 0.0      | 0.0  |
| Common Event Flag Wait     | 0.0         | 0.0         | 0.0      | 0.0  |
| Page Fault Wait            | 4.3         | 1.4         | 0.0      | 4.3  |
| Local Event Flag Wait      | 34.7        | 31.7        | 34.7     | 42.8 |
| Local Evt Flg (Outswapped) | 0.0         | 9.0         | 0.0      | 19.4 |
| Hibernate                  | 43.4        | 40.7        | 43.4     | 52.1 |
| Hibernate (Outswapped)     | 0.0         | 4.3         | 0.0      | 15.4 |
| Suspended                  | 0.0         | 0.0         | 0.0      | 0.0  |
| Suspended (Outswapped)     | 0.0         | 0.0         | 0.0      | 0.0  |
| Free Page Wait             | 0.0         | 0.0         | 0.0      | 0.0  |
| Compute                    | 13.0        | 7.3         | 4.3      | 13.0 |
| Compute (Outswapped)       | 0.0         | 0.8         | 0.0      | 3.2  |
| Current Process            | 1.0         | 1.0         | 1.0      | 1.0  |
| PLAYBACK                   | SUMMARIZING |             |          |      |

## **MONITOR MONITOR STATES**

The commands in this example generate and display a PROCESS STATES summary. Note that since use of the Return key is not permitted within a single MONITOR command following the MONITOR> prompt, the MONITOR command is entered at DCL level. The summary shows that, on the average, 14.1 percent of processes were swapped out for the summarized period. Note that the summary was requested for data covering only the hour between 1 P.M. and 2 P.M., although the input file could have contained data covering a longer period.

# MONITOR MONITOR SYSTEM

---

## MONITOR SYSTEM

The MONITOR SYSTEM command initiates monitoring of the SYSTEM statistics class, which shows several of the most important items from other classes.

### Format

MONITOR SYSTEM

### Command Qualifiers

**/qualifier[,...]**

One or more qualifiers as described in the Command Qualifier Descriptions section.

### Classname Qualifiers

**/ALL**

Specifies that a table of all available statistics (current, average, minimum, and maximum) is to be included in the display and summary output. For summary output, this qualifier is the default for all classes; otherwise, it is the default for all classes except CLUSTER, MODES, PROCESSES, STATES, SYSTEM, and VECTOR.

**/AVERAGE**

Specifies that a bar graph of average statistics is to be included in the display and summary outputs.

**/CURRENT**

Specifies that a bar graph of current statistics is to be included in the display and summary outputs. The /CURRENT qualifier is the default for the CLUSTER, MODES, STATES, SYSTEM, and VECTOR classes.

**/MAXIMUM**

Specifies that a bar graph of maximum statistics is to be included in the display and summary outputs.

**/MINIMUM**

Specifies that a bar graph of minimum statistics is to be included in the display and summary outputs.

### Description

Because the SYSTEM class collects the most significant performance statistics from other classes in a single display, it is particularly useful to system managers and other users seeking a general overview of system activity. The SYSTEM class includes the following data items:

- Interrupt State
- MP Synchronization
- Kernel Mode
- Executive Mode
- Supervisor Mode
- User Mode
- Idle Time
- Process Count



Page Fault Rate  
 Page Read I/O Rate  
 Free List Size  
 Modified List Size  
 Direct I/O Rate  
 Buffered I/O Rate

The following two display formats are provided, depending on the classname qualifier specified:

- A tabular style format for the /ALL qualifier
- A bar graph style format for the /AVERAGE, /CURRENT, /MAXIMUM, and /MINIMUM qualifiers

Examples of these formats are at the end of this section. Note that the bar graph version of the SYSTEM class (shown in Example 2) contains the following data, which differs from the tabular version:

- All of the CPU processor modes except Idle Time are summarized in the CPU Busy segment.
- In the Page Fault segment, the page read I/O rate is indicated by a vertical bar. The bar provides a visual estimate of the proportion of the total page fault rate that caused read I/O operations (the hard fault rate). The hard fault rate appears to the left of the bar.
- Four segments show the processes that are currently the top consumers of CPU (since the last screen update), page faults, direct I/Os, and buffered I/Os.

Beginning in OpenVMS Version 7.3, the following rate fields have increased in the MONITOR SYSTEM bar graph screen display:

| Rate Name  | Old Rate           | New Rate   |
|--|--------------------|--|
| Page Fault   | 100                | 500  |
| Hard Page Fault<br>(vertical line on Page Fault display) | 100                | 500  |
| Direct I/O   | 60                 | 500  |
| Free List Size   | Shown in K blocks  | Shown in K, M, or G blocks (whichever is appropriate)  |
| Mod (modified) List Size                                 | 5 digits; K blocks | 8 digits; K, M, or G blocks (whichever is appropriate) |
| Buffered I/O   | 150                | 500  |

Any process that MONITOR designates as a top user process must be swapped in at the beginning and ending of the display interval or at the beginning and ending of the entire period covered by a summary.

When the lower bar graph (top user) and the corresponding upper bar graph (overall system measure) are tracking the same statistic for the same interval (as in Example 2), it is reasonable to compare the two graphs. This will be the case in the following situation:

- SYSTEM is the only class being monitored (no other class names have been specified with the MONITOR command).
- The CURRENT statistic is specified.

## MONITOR MONITOR SYSTEM

- The /INTERVAL and /VIEWING\_TIME values are equal.

Otherwise, exercise care in making such comparisons because the top user statistic is always CURRENT, while the overall system measure statistic may be CURRENT, AVERAGE, MAXIMUM, or MINIMUM.

Rates for top users are calculated based on the interval between two successive screen displays, while overall system rates are based on the collection interval. These two interval values can be different whenever one or more classes are being monitored with the SYSTEM class, or when /INTERVAL and /VIEWING\_TIME values differ.

While other upper boundary figures for the SYSTEM class bar graphs are constants, the figures for Free List Size and Modified List Size are derived from the physical memory configuration and system parameters of individual systems. The upper boundary figure for the Free List is the number of pages available after deducting the pages permanently allocated to the operating system. This figure, sometimes referred to as **balance set memory**, is the number of pages that can be allocated to processes, the Free List, and the Modified List. The upper boundary figure for the Modified List is the value of the MPW\_HILIMIT system parameter. Note that both upper boundary figures are calculated when the MONITOR request is initiated and do not change thereafter.

### Examples

1. MONITOR> MONITOR SYSTEM/ALL

```
OpenVMS Monitor Utility
SYSTEM STATISTICS
on node SAMPLE
29-APR-2003 12:43:28
```

|                    | CUR     | AVE     | MIN     | MAX     |
|--------------------|---------|---------|---------|---------|
| Interrupt Stack    | 0.33    | 0.33    | 0.33    | 0.33    |
| MP Synchronization | 0.00    | 0.00    | 0.00    | 0.00    |
| Kernel Mode        | 0.16    | 0.16    | 0.16    | 0.16    |
| Executive Mode     | 0.00    | 0.00    | 0.00    | 0.00    |
| Supervisor Mode    | 0.00    | 0.00    | 0.00    | 0.00    |
| User Mode          | 0.50    | 0.49    | 0.50    | 0.50    |
| Compatibility Mode | 0.00    | 0.00    | 0.00    | 0.00    |
| Idle Time          | 99.00   | 98.67   | 99.00   | 99.00   |
| Process Count      | 14.00   | 14.00   | 14.00   | 14.00   |
| Page Fault Rate    | 0.33    | 0.33    | 0.33    | 0.33    |
| Page Read I/O Rate | 0.00    | 0.00    | 0.00    | 0.00    |
| Free List Size     | 4255.00 | 4255.00 | 4255.00 | 4255.00 |
| Modified List Size | 105.00  | 105.00  | 105.00  | 105.00  |
| Direct I/O Rate    | 0.00    | 0.00    | 0.00    | 0.00    |
| Buffered I/O Rate  | 0.16    | 0.16    | 0.16    | 0.16    |

This example shows the tabular style format for the SYSTEM display.

# MONITOR MONITOR SYSTEM

## 2. MONITOR> MONITOR SYSTEM

```

Node: BRS004                OpenVMS Monitor Utility      5-JUN-2003 10:45:32
Statistic: CURRENT          SYSTEM STATISTICS

                                Process States
CPU      0 + CPU Busy (400)      -+      LEF:   15      LEFO:   0
          |*****|              HIB:   14      HIBO:   0
          +-----+ 400        COM:    8      COMO:   0
          |*|                    PFW:    0      Other:  1
          +-----+          MWAIT:  0
          Cur Top: BATCH_27 (6)      Total: 38

MEMORY   0 + Page Fault Rate (1438) -+      + Free List Size (35173) +
          |****|*****|          |*****| 54K
          +-----+ 500        0 +-----+
          |****|              |*****| 5765
          +-----+          + Mod List Size (3078) +
          Cur Top: BATCH_29 (78)

I/O      0 + Direct I/O Rate (442) -+      + Buffered I/O Rate (112) -+
          |*****|              |*****|
          +-----+ 500        0 +-----+ 500
          |*|                    |
          +-----+          +-----+
          Cur Top: BATCH_24 (23)      Cur Top: BATCH_24 (6)

```

This example shows the bar graph style format for the SYSTEM display.

## 3. MONITOR> MONITOR SYSTEM

```

Node: ADU26B                OpenVMS Monitor Utility      28-SEP-2004 16:05:29
Statistic: CURRENT          SYSTEM STATISTICS

                                Process States
CPU      0 + CPU Busy (0)        -+      LEF:    1      LEFO:   0
          | |                    HIB:   20      HIBO:   0
          +-----+ 200        COM:    0      COMO:   0
          | |                    PFW:    0      CUR:    1
          +-----+          MWAIT:  0      Other:  0
          Cur Top: (0)          Total: 22

MEMORY   0 + Page Fault Rate (0) -+      + Free List Size (98588) +
          ||                    |*****| 128K
          +-----+ 500        0 +-----+
          | |                    |*****| 32K
          +-----+          + Mod List Size (889) +
          Cur Top: (0)

I/O      0 + Direct I/O Rate (0) -+      + Buffered I/O Rate (0) -+
          | |                    | |
          +-----+ 500        0 +-----+ 500
          | |                    |
          +-----+          +-----+
          Cur Top: (0)          Cur Top: (0)

```

This example shows format for the SYSTEM display on an Integrity servers system, including a CUR (current) field.

# MONITOR

## MONITOR TIMER

---

### MONITOR TIMER

The MONITOR TIMER command initiates monitoring of the TIMER statistics class, which is the rate of processing Timer Queue Entries (TQEs) by the OpenVMS executive. A TQE is a data structure representing a timer request made by a user or by the system.

#### Format

MONITOR TIMER

#### Command Qualifiers

**/qualifier[,...]**

One or more qualifiers as described in the Command Qualifier Descriptions section.

#### Classname Qualifiers

**/ALL**

Specifies that a table of all available statistics (current, average, minimum and maximum) is to be included in the display and summary outputs. For summary output, this qualifier is the default for all classes; otherwise, it is the default for all classes except CLUSTER, MODES, PROCESSES, STATES, SYSTEM, and VECTOR.

**/AVERAGE**

Specifies that a bar graph of average statistics is to be included in the display and summary outputs.

**/CURRENT**

Specifies that a bar graph of current statistics is to be included in the display and summary outputs. The /CURRENT qualifier is the default for the CLUSTER, MODES, STATES, SYSTEM, and VECTOR classes.

**/MAXIMUM**

Specifies that a bar graph of maximum statistics is to be included in the display and summary outputs.

**/MINIMUM**

Specifies that a bar graph of minimum statistics is to be included in the display and summary outputs.

#### Description

The TIMER class consists of the following data items, which are displayed as rates of occurrences per second:

---

| <b>Data Item</b> | <b>Description</b>  |
|------------------|---|
| Total TQE Rate   | Total Rate of TQEs processed per second. This statistic is a combined total of the three following TQE rates. |

---

## MONITOR MONITOR TIMER

| Data Item       | Description  |
|-----------------|--|
| SYSUB TQE Rate  | Rate of SYSUB TQEs processed per second. These system subroutine TQEs represent timer requests made by the OpenVMS operating system. |
| Timer TQE Rate  | Rate of Timer TQEs processed per second. These TQEs represent timer requests made by users through the \$SETIMR system service.      |
| Wakeup TQE Rate | Rate of wakeup TQEs processed per second. These TQEs represent timer requests made by users through the \$SCHDWK system service.     |

### Examples

1. MONITOR> MONITOR TIMER

```
OpenVMS Monitor Utility
TIMER STATISTICS
on node EBJB28
6-OCT-2003 08:46:13.84

                CUR      AVE      MIN      MAX
Total TQE Rate      56.00    56.00    56.00    56.00
SYSUB TQE Rate      51.33    51.33    51.33    51.33
Timer TQE Rate       4.33     4.33     4.33     4.33
Wakeup TQE Rate      0.33     0.33     0.33     0.33
```

This example shows a relatively low over-all level of TQE processing, most of which has been requested by OpenVMS. Note that the last three rates approximately total the first rate.

# MONITOR MONITOR TRANSACTION

---

## MONITOR TRANSACTION

The MONITOR TRANSACTION command initiates monitoring of the TRANSACTION class, which shows information about transactions coordinated by DECdtm services.

### Format

MONITOR TRANSACTION

### Command Qualifiers

**/qualifier[,...]**

One or more qualifiers as described in the Command Qualifier Descriptions section.

### Classname Qualifiers

**/ALL**

Specifies that a table of all available statistics (current, average, minimum, and maximum) is to be included in the display and summary output. For summary output, this qualifier is the default for all classes; otherwise, it is the default for all classes except CLUSTER, MODES, PROCESSES, STATES, SYSTEM, and VECTOR.

**/AVERAGE**

Specifies that a bar graph of average statistics is to be included in the display and summary outputs.

**/CURRENT**

Specifies that a bar graph of current statistics is to be included in the display and summary outputs. The /CURRENT qualifier is the default for the CLUSTER, MODES, STATES, SYSTEM, and VECTOR classes.

**/MAXIMUM**

Specifies that a bar graph of maximum statistics is to be included in the display and summary outputs.

**/MINIMUM**

Specifies that a bar graph of minimum statistics is to be included in the display and summary outputs.

### Description

The TRANSACTION class consists of the following data items:

---

| <b>Data Item</b> | <b>Description</b>  |
|------------------|---|
| Start Rate       | The rate at which new transactions are started on the local node.                                     |
| Prepare Rate     | The rate at which transactions on the local node are placed in the Prepared state by DECdtm services. |

## MONITOR MONITOR TRANSACTION

| Data Item             | Description  |                     |  |                     |   |                     |   |                     |   |                     |   |                    |  |
|-----------------------|--|---------------------|--|---------------------|---|---------------------|---|---------------------|---|---------------------|---|--------------------|--|
| One-Phase Commit Rate | The rate at which transactions on the local node complete using the one-phase commit operation. This operation, which consumes significantly fewer system resources, is used when there is only a single resource manager participating in the transaction.  |                     |  |                     |   |                     |   |                     |   |                     |   |                    |  |
| Total Commit Rate     | The rate at which transactions on the local node are committed. This value is the combined total of one-phase and two-phase commit transactions.   |                     |  |                     |   |                     |   |                     |   |                     |   |                    |  |
| Abort Rate            | The rate at which transactions on the local node are aborted.  |                     |  |                     |   |                     |   |                     |   |                     |   |                    |  |
| End Rate              | The rate at which transactions that were started on the local node are committed.  |                     |  |                     |   |                     |   |                     |   |                     |   |                    |  |
| Remote Start Rate     | The rate at which transaction branches are started on the local node.  |                     |  |                     |   |                     |   |                     |   |                     |   |                    |  |
| Remote Add Rate       | The rate at which transaction branches are added on the local node.  |                     |  |                     |   |                     |   |                     |   |                     |   |                    |  |
| Completion Rate       | <p>The rate at which transactions complete, indexed by their duration in seconds. The following list shows the Completion Rate categories:</p> <table style="width: 100%; border-collapse: collapse;"> <tbody> <tr> <td style="width: 30%;">Completion Rate 0–1</td> <td>The number of transactions completed in 0–1 seconds (1 second or less)</td> </tr> <tr> <td>Completion Rate 1–2</td> <td>The number of transactions completed in 1–2 seconds</td> </tr> <tr> <td>Completion Rate 2–3</td> <td>The number of transactions completed in 2–3 seconds</td> </tr> <tr> <td>Completion Rate 3–4</td> <td>The number of transactions completed in 3–4 seconds</td> </tr> <tr> <td>Completion Rate 4–5</td> <td>The number of transactions completed in 4–5 seconds</td> </tr> <tr> <td>Completion Rate 5+</td> <td>The number of transactions that took more than 5 seconds to complete</td> </tr> </tbody> </table> <p>For example, a transaction that completes in 0.5 second is included in the statistics displayed for the Completion Rate 0–1 category.</p> | Completion Rate 0–1 | The number of transactions completed in 0–1 seconds (1 second or less) | Completion Rate 1–2 | The number of transactions completed in 1–2 seconds | Completion Rate 2–3 | The number of transactions completed in 2–3 seconds | Completion Rate 3–4 | The number of transactions completed in 3–4 seconds | Completion Rate 4–5 | The number of transactions completed in 4–5 seconds | Completion Rate 5+ | The number of transactions that took more than 5 seconds to complete |
| Completion Rate 0–1   | The number of transactions completed in 0–1 seconds (1 second or less)   |                     |  |                     |   |                     |   |                     |   |                     |   |                    |  |
| Completion Rate 1–2   | The number of transactions completed in 1–2 seconds  |                     |  |                     |   |                     |   |                     |   |                     |   |                    |  |
| Completion Rate 2–3   | The number of transactions completed in 2–3 seconds  |                     |  |                     |   |                     |   |                     |   |                     |   |                    |  |
| Completion Rate 3–4   | The number of transactions completed in 3–4 seconds  |                     |  |                     |   |                     |   |                     |   |                     |   |                    |  |
| Completion Rate 4–5   | The number of transactions completed in 4–5 seconds  |                     |  |                     |   |                     |   |                     |   |                     |   |                    |  |
| Completion Rate 5+    | The number of transactions that took more than 5 seconds to complete   |                     |  |                     |   |                     |   |                     |   |                     |   |                    |  |

# MONITOR MONITOR TRANSACTION

## Examples

1. MONITOR> MONITOR TRANSACTION/ALL

```

                                OpenVMS Monitor Utility
                                DISTRIBUTED TRANSACTION STATISTICS
                                on node SAMPLE
                                16-JAN-2003 14:52:34

```

|                       | CUR   | AVE   | MIN   | MAX   |
|-----------------------|-------|-------|-------|-------|
| Start Rate            | 34.76 | 34.76 | 34.76 | 34.76 |
| Prepare Rate          | 33.77 | 33.77 | 33.77 | 33.77 |
| One Phase Commit Rate | 0.00  | 0.00  | 0.00  | 0.00  |
| Total Commit Rate     | 35.09 | 35.09 | 35.09 | 35.09 |
| Abort Rate            | 0.00  | 0.00  | 0.00  | 0.00  |
| End Rate              | 35.09 | 35.09 | 35.09 | 35.09 |
| Remote Start Rate     | 31.12 | 31.12 | 31.12 | 31.12 |
| Remote Add Rate       | 31.45 | 31.45 | 31.45 | 31.45 |
| Completion Rate 0-1   | 35.09 | 35.09 | 35.09 | 35.09 |
| by Duration 1-2       | 0.00  | 0.00  | 0.00  | 0.00  |
| in Seconds 2-3        | 0.00  | 0.00  | 0.00  | 0.00  |
| 3-4                   | 0.00  | 0.00  | 0.00  | 0.00  |
| 4-5                   | 0.00  | 0.00  | 0.00  | 0.00  |
| 5+                    | 0.00  | 0.00  | 0.00  | 0.00  |

This example shows the status of all transactions on node SAMPLE.

2. MONITOR> MONITOR TRANSACTION/MAXIMUM

```

                                OpenVMS Monitor Utility
                                DISTRIBUTED TRANSACTION STATISTICS
                                on node SAMPLE
                                16-JAN-2003 14:51:04

```

|                       | 0  | 25    | 50 | 75 | 100 |
|-----------------------|----|-------|----|----|-----|
| Start Rate            | 35 | ***** |    |    |     |
| Prepare Rate          | 37 | ***** |    |    |     |
| One Phase Commit Rate |    |       |    |    |     |
| Total Commit Rate     | 35 | ***** |    |    |     |
| Abort Rate            |    |       |    |    |     |
| End Rate              | 35 | ***** |    |    |     |
| Remote Start Rate     | 33 | ***** |    |    |     |
| Remote Add Rate       | 32 | ***** |    |    |     |
| Completion Rate 0-1   | 35 | ***** |    |    |     |
| by Duration 1-2       |    |       |    |    |     |
| in Seconds 2-3        |    |       |    |    |     |
| 3-4                   |    |       |    |    |     |
| 4-5                   |    |       |    |    |     |
| 5+                    |    |       |    |    |     |

This example shows the maximum statistics of all transactions on node SAMPLE.



---

## **MONITOR VECTOR**

The **MONITOR VECTOR** command displays the number of 10-millisecond clock ticks per second in which one or more vector consumers have been scheduled on each currently configured vector processor in the system.

### **Format**

**MONITOR VECTOR**

### **Command Qualifiers**

**/qualifier[,...]**

One or more qualifiers as described in the Command Qualifier Descriptions section.

### **Classname Qualifiers**

**/ALL**

Specifies that a table of all available statistics (current, average, minimum, and maximum) is to be included in the display and summary output. For summary output, this qualifier is the default for all classes; otherwise, it is the default for all classes except **CLUSTER**, **MODES**, **PROCESSES**, **STATES**, **SYSTEM**, and **VECTOR**.

**/AVERAGE**

Specifies that a bar graph of average statistics is to be included in the display and summary outputs.

**/CURRENT**

Specifies that a bar graph of current statistics is to be included in the display and summary outputs. The **/CURRENT** qualifier is the default for the **CLUSTER**, **MODES**, **STATES**, **SYSTEM**, and **VECTOR** classes.

**/MAXIMUM**

Specifies that a bar graph of maximum statistics is to be included in the display and summary outputs.

**/MINIMUM**

Specifies that a bar graph of minimum statistics is to be included in the display and summary outputs.

### **Description**

The **MONITOR VECTOR** command displays the number of 10-millisecond clock ticks per second in which one or more vector consumers have been scheduled on each currently configured vector processor in the system. Because the operating system schedules vector consumers only on those processors identified as “vector present,” the **VECTOR** class output never displays vector CPU time for those processors that are “vector absent.”

Note that, because vector consumers can use either the vector CPU, the scalar CPU, or both components of a vector-present processor, the vector CPU time in the **VECTOR** class display is not a strict measure of the actual usage of the processor’s vector CPU component. Rather, it indicates the time during which

# MONITOR

## MONITOR VECTOR

a scheduled vector consumer has reserved both vector CPU and scalar CPU components of the vector-present processor for its own exclusive use.

The VECTOR class consists of the data item Vector Scheduled Rate, which is represented by a display of statistics that show the rates of 10-millisecond clock ticks per second during which vector consumers have been scheduled on each vector-present CPU.

### Example

```
MONITOR> MONITOR VECTOR
```

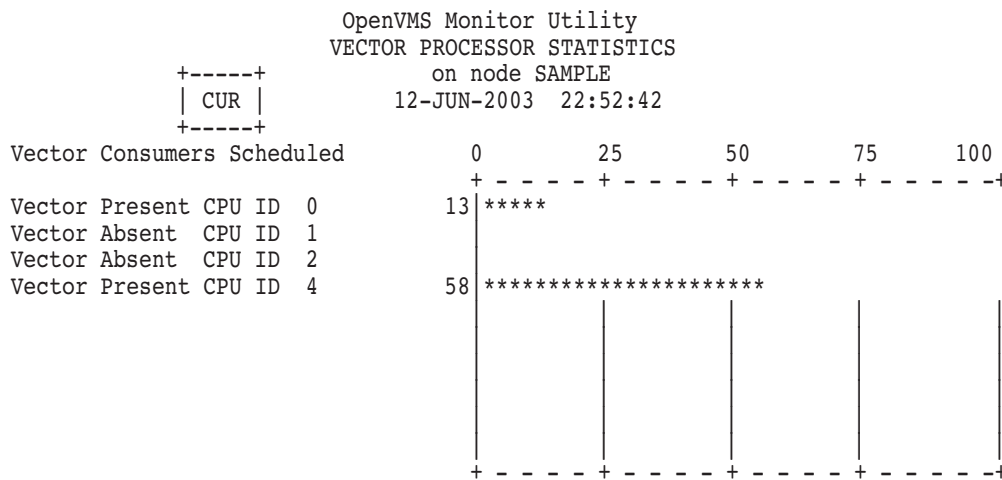

This example shows the VECTOR class display for a multiprocessing system containing two vector-present processors, CPU 0 and CPU 4. Displayed statistics represent rates of 10-millisecond clock ticks per second. For an average of 13 ticks per second over the last collection interval, vector consumers have been scheduled on CPU 0. For an average of 58 ticks per second over the last collection interval, vector consumers have been scheduled on CPU 4.

---

**SET DEFAULT**

The SET DEFAULT command sets command qualifier, classname parameter, and classname qualifier defaults for the MONITOR command. Each SET DEFAULT command sets only the command qualifiers you specify, but replaces the entire set of classname parameters and classname qualifiers. All qualifiers and class names are identical to those for the MONITOR command.

**Format**

```
SET DEFAULT [/qualifier[,...]] classname[,...] [/qualifier[,...]]
```

**Parameters**

**classname[,...]**  
Specifies one or more class names.

**Command Qualifiers**

**/qualifier[,...]**  
One or more command qualifiers as described in the Command Qualifier Descriptions section.

**Classname Qualifiers**

**/qualifier[,...]**  
One or more classname qualifiers.

**Description**

Command and classname qualifiers are identical to those for the MONITOR classname commands.

**Example**

```
MONITOR> SET DEFAULT /INTERVAL=10 PAGE/AVERAGE+IO/MAXIMUM /NODE=(LARRY,MOE,CURLEY)
```

The command in this example selects PAGE and IO as the default classes for the MONITOR command and specifies an interval of 10 seconds for the statistics display. The command specifies that AVERAGE statistics be displayed for the PAGE class, and that MAXIMUM statistics be displayed for the IO class. Finally, the command requests that data be collected on nodes LARRY, MOE, and CURLEY. After establishing these defaults, you can enter the MONITOR command without any qualifiers or parameters to display the requested information.

# MONITOR

## SHOW DEFAULT

---

### SHOW DEFAULT

The SHOW DEFAULT command displays the defaults established by the SET DEFAULT command.

#### Format

```
SHOW DEFAULT
```

#### Parameters

None.

#### Qualifiers

None.

#### Description

The SHOW DEFAULT command verifies the defaults you have set with the SET DEFAULT command.

#### Example

```
MONITOR> SHOW DEFAULT
```

```
/BEGINNING = current time          /INTERVAL      = 10
/ENDING     = indefinite            /VIEWING_TIME = 10
/FLUSH_INTERVAL = 300
/NOINPUT
/NORECORD
/DISPLAY    = SYS$OUTPUT:.;
/NOSUMMARY
/NOFILENAME
/NOCOMMENT
Classes:
  PAGE/AVERAGE          IO/MAXIMUM
Nodes:
  LARRY                 MOE                CURLEY
```

The command in this example displays the defaults specified by the previous SET DEFAULT command.

---

## MSA Utility

This chapter contains information about the MSA utility.

### 2.1 MSA Utility Usage Summary

The MSA utility is an OpenVMS system management tool for configuring and managing the following controllers:

- HP StorageWorks Smart Array Family of Storage Host Bus Adapters (5300 series, 6400 series, P400, P410i, P411, P700, and P800 with Native Command Queuing (NCQ) Firmware)
- HP StorageWorks Modular Smart Array Family of Storage Controllers (MSA1000 and MSA1500)
- Support for SB40c blade storage and the disk numbering changes

These controllers connect to HP StorageWorks Modular Smart Array storage array systems, and to Integrity servers internal SCSI or SAS drives.

#### 2.1.1 Required Privileges

You must have the following privileges to run the MSA utility: NETMBX, TMPMBX, SYSPRV, DIAGNOSE, PHY\_IO.

To start the MSA utility, enter the following command at the DCL command prompt (\$):

```
$ RUN SYS$SYSTEM:MSA$UTIL
```

The MSA utility returns the following prompt:

```
MSA>
```

At the MSA prompt, you can enter any MSA utility command described in the following sections.

#### 2.1.2 Restrictions

The MSA Utility has the following restrictions:

- The MSA\_UTIL command SHOW CONNECTIONS is not applicable to or supported on the HP StorageWorks Smart Array Controller.
- EXTEND, MIGRATE, and EXPAND commands on Smart Array systems will fail if the controller cache is bad or the cache battery is less than 75%. These commands work on controllers that are designed to support volume expansion by using disk drives for backing up expand data stripe. This is in the absence of battery-backed memory on the controller.
- RAID units that have spare disks (RAID 1, RAID 5, and so on) cannot be migrated to RAID 0 or JBOD units.

## **MSA Utility**

### **2.1 MSA Utility Usage Summary**

- Multiple-capacity disks can be used by specifying the /SIZE qualifier. The maximum value of size specified with the /SIZE qualifier should be the size available on the disk with the lowest capacity.

### **2.2 MSA Utility Commands**

The following sections describe MSA utility commands and provide examples of their use. Note that some qualifiers are shown as abbreviated in the examples.

---

## **ACCEPT UNIT**

Changes the state of the unit back to VOLUME\_OK when all drives of a previously failed unit are in working order.

This command accepts media exchange on a unit marked as failed.

---

**Note**

---

The ACCEPT UNIT command resets the status of all failed units to VOLUME\_OK.

---

### **Format**

ACCEPT UNIT <#>

where # represents the unit number.

### **Example**

```
MSA> ACCEPT UNIT 2
```

## **ADD UNIT**

Creates units (logical storage units that comprise one or more hard drives).

### **Format**

ADD UNIT <unit\_n> / <qualifiers> unit\_n

### **Parameters**

#### **unit\_n**

The unit number can range from 0-31.

---

#### **Note**

---

Any two or a combination of all the following qualifiers cannot be used in conjunction with each other.

---

### **Qualifiers**

#### **/ADG**

Specifies the RAID type for the unit as Advanced Data Guard (ADG).

#### **/CACHE**

Determines whether the controller's cache must be used for the UNIT. Caching is ON by default. To disable caching, use a /NOCACHE qualifier with SET UNIT or ADD UNIT commands.

#### **/DISK**

Specifies the disk numbers to be used to form the unit. Enclose multiple disks in parentheses. Use the following format:

```
/DISK=(disk-numbers[,...])
```

#### **/IDENTIFIER**

User-defined identifier for the unit. This identifier is used by OpenVMS to name the device. The value of the identifier *n* is between 1 and 9999. Use the following format:

```
/IDENTIFIER= n
```

---

#### **Note**

---

The /IDENTIFIER qualifier is not required for Smart Array controllers.

---

#### **/JBOD**

Specifies the RAID type as JBOD. Synonymous with RAID 0.

#### **/PARTITION**

Specifies the partition number to be used for a given unit. The first unit that is created on a disk/disk group is automatically assigned the partition number 0. Units that are subsequently created on this disk/disk group must be created with sequential partition numbers. Use the following format:



`/PARTITION=(partition_number)`

#### **/RAID\_LEVEL**

Specifies the RAID type of the unit. Supported values for this qualifier are 0 (data striping), 1 (data mirroring), 5 (data striping with striped parity), 50 (data striping with parity), and 60 (data striping with parity).

Use the following format:

`/RAID={ (0 | 1 | 5 | 50 | 60) }`

#### **/SIZE**

Specifies the size of the unit. If the size qualifier is not specified, the size defaults to the maximum capacity of the disks depending on the RAID level, as shown in the following example:

`/SIZE=#(GB | MB | KB | %)`

#### **/SPARE**

Specifies the disk numbers to be used as spare disks. Enclose multiple disks in parentheses. Assigning a spare disk to an unit in a drive group assigns the spare disk to all the configured units in the drive group.

If a unit is created on a disk group to which a spare disk is assigned, then the spare disk is configured to the new unit (if it is not a RAID 0 unit). One spare disk can be assigned to multiple drive groups.

Ensure that the size of the spare disk is equal at least to the size of the smallest drive in the drive group. Use the following format:

`/SPARE=(disk_number[,...])`

#### **/STRIPE\_SIZE**

Specifies the stripe size for a given RAID volume. Stripe size must be one of the following values: 8, 16, 32, 64, 128, or 256. Raid 5 and ADG are limited to a maximum 64 KB stripes. RAID 0 and 1 default to 128 KB stripes, and RAID 5 and ADG default to 16 KB stripes. Use the following format:

`/STRIPE_SIZE=(stripe_size)`

#### **/VERBOSE**

Provides logging that can be interpreted by engineering.

## **Restrictions**

Any two or a combination of all the following qualifiers cannot be used in conjunction with each other.

`/RAID_LEVEL, /JBOD, /ADG`

## **Examples**

1. MSA> ADD UNIT 2

This command creates unit 2.

## MSA Utility ADD UNIT

2. MSA> ADD UNIT 3/ID=1003/DISK=103/JBOD/PARTITION=0/SIZE=8GB  
MSA> ADD UNIT 4/ID=1004/DISK=103/JBOD/PARTITION=1/SIZE=10GB  
MSA> ADD UNIT 5/ID=1005/DISK=103/JBOD/PARTITION=2/SIZE=8GB

These commands create three units on disk 103. Notice that the partition numbers are provided in sequential order on the same disk/disk group.

3. MSA> ADD UNIT 3/ID=1003/DISK=103/JBOD/PARTITION=0/SIZE=8GB  
MSA> ADD UNIT 4/ID=1004/DISK=103/JBOD/PARTITION=2/SIZE=10GB

In this command sequence, assume that there is no unit with partition number 1 on this disk, the creation of unit 4 will fail because the unit is assigned the partition number 2 and the assignment is not in sequential order.

---

## DELETE UNIT

Delete units from the drive. Regardless, whether the disk is mounted on OpenVMS, you are prompted for confirmation before proceeding to delete the selected unit.

For example, if the disk is mounted on an OpenVMS node, in addition to the prompting for confirmation, you are informed that the disk is mounted.

---

### Note

---

After a unit is deleted, its unit number remains unused until manually assigned to a new unit.

Unit numbers are not automatically reassigned when a unit is deleted.

If more than one unit has been created on a disk/disk group, only the last created unit can be deleted.

Be sure to maintain a record of the unit numbers and the order in which they are created on a disk/disk group.

---

## Format

```
DELETE UNIT <unit_n> / <qualifiers> unit_n
```

## Parameters

**unit\_n**

The unit number can range from 0-31.

## Qualifiers

**/VERBOSE**

Provides logging that can be interpreted by engineering.

**/NOCONFIRM**

Allows the specified unit to be deleted without prompting for confirmation.

## Example

```
MSA> DELETE UNIT 4/NOCONFIRM
```

In this example, unit 4 is the unit to be deleted. This is the same number that is given to the unit when it was created using the ADD UNIT command. The /NOCONFIRM qualifier deletes unit 4 without prompting for confirmation.

**MSA Utility**  
**EXIT**

---

**EXIT**

Exits the MSA\$UTIL program.

## FLASH FIRMWARE

Updates the firmware of a given controller. Specify the firmware file name to be used.

### Format

FLASH FIRMWARE <firmware-file-name> / <qualifiers> firmware-file-name

### Parameters

**firmware-file-name**

### Qualifiers

**/VERBOSE**

Provides logging that can be interpreted by engineering.

## MSA Utility HELP

---

### HELP

Describes all currently supported MSA\$UTIL commands, their parameters, and their qualifiers. Use the following format, where *verb* is the specific description.

### Format

```
HELP <verb> verb
```

### Parameters

**verb**

### Example

```
MSA> Help ADD
ADD
UNIT
    ADD UNIT is used to create UNITS (logical storage units comprising
    one or more hard drives).
Format:
ADD UNIT <unit_n> <qualifiers>
Parameters  Qualifiers  Examples
```

This command describes the ADD command and its parameters.

---

## LOCATE

Causes the LEDs of the requested drives to blink. These LEDs are visible from the front of the attached storage enclosures.

---

### Note

---

If time limit is not included with the LOCATE command, the LEDs blink for 30 seconds. In some cases, the LEDs may remain steady without blinking. Furthermore, the LOCATE command does not work from a STANDBY CONTROLLER.

---

## Format

LOCATE/TIME=xxx <parameters> / <qualifiers> ALL

## Parameters

### ALL

Causes all drives connected to the MSA storage subsystem to flash.

### BOX

The LOCATE BOX command causes the disks connected to the specified box/enclosure number to flash.

### BUS *bus-number*

Causes the disks connected to the specified bus to flash.

### CANCEL

Cancels the current locate operation.

### DISK *disk-number*

The LOCATE DISKS command makes the specified drive to flash. Disks are identified by their corresponding SCSI bus and SCSI IDs for all the controllers. For SAS controllers, internally connected disks are numbered based on their bay numbers and externally connected disks are numbered based on a combination of their box number and bay number as "disk\_n = box number \*100 + bay number".

---

### Note

---

The disk numbers for the existing disks can be obtained using the SHOW DISKS command.

---

### UNIT *unit-number*

Causes the disks configured on the specified unit to flash.

## MSA Utility LOCATE

### Qualifiers

#### **/TIME=time**

Specifies the number of seconds the disk's LED should flash. This is an optional qualifier whose default is 30 seconds.

#### **/VERBOSE**

Provides logging that can be interpreted by engineering.

### Examples

1. MSA> LOCATE ALL

This command locates all drives attached to the storage enclosure.

2. MSA> LOCATE BUS 1

This command locates all drives SCSI bus 1.

3. MSA> LOCATE UNIT 1

This command locates all drives in unit 1.

4. MSA> LOCATE DISK 102

This command locates drive 102.

5. MSA> LOCATE BOX 1

This command locates and flashes all the drives in the specified BOX 1.



## READ FIRMWARE

Reads the firmware image on the controller.

---

**Note**

---

Supported only for Smart Array 5300 and Smart Array 6400 series controllers.

---

### Format

READ FIRMWARE <firmware file-name> / <qualifiers> firmware file name

### Parameters

**firmware file name**

Specifies the file name of the firmware image.

### Qualifiers

**/VERBOSE**

Provides logging that can be interpreted by engineering.

## MSA Utility RESET THIS\_CONTROLLER

---

### RESET THIS\_CONTROLLER

Issues a controller reset to the specified controller.

#### Format

RESET THIS\_CONTROLLER <parameters> / <qualifiers> CONTROLLER\_TYPE

#### Parameters

##### **CONTROLLER\_TYPE**

Issues a controller reset to the specified controller.

---

##### **Note**

---

Applicable only for MSA1000/1500 controllers.

---

#### Qualifiers

##### **/VERBOSE**

Provides logging that can be interpreted by engineering.

#### Example

```
MSA> RESET THIS_CONTROLLER
```

---

## RESET OTHER\_CONTROLLER

Issues a reset to the controller. The state of this controller can be either ACTIVE or STANDBY.

### Format

RESET OTHER\_CONTROLLER / <qualifiers> CONTROLLER\_TYPE

### Parameters

#### CONTROLLER\_TYPE

Issues a controller reset to the specified controller.

---

**Note**

---

Applicable only for MSA1000/1500 controllers.

---

### Qualifiers

#### /VERBOSE

Provides logging that can be interpreted by engineering.

### Example

```
MSA> RESET OTHER_CONTROLLER
```

## MSA Utility

### SCAN ALL

---

#### SCAN ALL

Sends a scan message to the Smart Array controller instructing it to scan SCSI buses and discover new or replaced disks. After the scan is complete, the rebuild operation for the logical volumes is initiated for all the units configured in the disk group.

This command is applicable only for the internal disk enclosure connected to the Smart Array on Integrity server platforms.

---

#### Note

---

For additional information on rebuild of volumes, see the START RECOVER command.

---

#### Format

SCAN ALL

#### Parameters

None

#### Qualifiers

None

#### Example

```
MSA> SCAN ALL
```

---

## SET CONTROLLER

Selects the controller device-name as the default controller. The device name has the format *ddcu:*, where:

*dd* is the device code.

*c* is the controller designation (A through Z).

*u* is the unit number (0 through 9999).

This command is required before entering all SAS utility commands except SHOW CONTROLLER and SHOW VERSION.

---

### Note

---

SET CONTROLLER command is synonymous with the SET ADAPTER command.

---

## Format

SET CONTROLLER [ddcu:] / <qualifiers>

## Parameters

None

## Qualifiers

### **/DEFAULT**

Specifies the default controller.

### **/VERBOSE**

Provides logging that can be interpreted by engineering.

## Example

```
MSA> SET CONTROLLER $1$GGA105:
```

This command sets controller \$1\$GGA105 as the default controller.

## **SET GLOBALS**

Set the expand priority, the read/write ratio, and the system name.

### **Format**

SET GLOBALS / <qualifiers>

### **Parameters**

None

### **Qualifiers**

#### **/EXPAND\_PRIORITY=(LOW | MEDIUM | HIGH)**

Sets the default controller.

Specifies the expand priority. Use when expanding an array to set the priority of array expansions in relation to input/output (I/O) operations. Use in the following format:

/EXPAND\_PRIORITY=(LOW | MEDIUM | HIGH)

#### **/READ\_CACHE=value**

Specifies the percentage of cache to be used with the READ command.

This value must be between 0 and 100. Use the following format:

/READ\_CACHE=(AUTOMATIC | percent)

---

#### **Note**

---

Combined, the values of the /READ\_CACHE and the /WRITE\_CACHE qualifiers must equal 100.

---

#### **/REBUILD\_PRIORITY=(LOW | MEDIUM | HIGH)**

Specifies the rebuild priority of the RAID volume.

Use when rebuilding an array to set the priority of an array rebuild in relation to input/output (I/O) operations. Low expansion or rebuild applies only when the array controller is not busy handling normal I/O requests. This setting has minimal effect on normal I/O operations. However, there is an increased risk that data will be lost if another physical drive fails while the rebuild is in progress. Use the following format:

/REBUILD\_PRIORITY=(LOW | MEDIUM | HIGH)

#### **/WRITE\_CACHE=value**

Specifies the percentage of cache to be used with the WRITE command.

The value must be between 0 and 100.

---

**Note**

Combined, the values of the /READ\_CACHE and the /WRITE\_CACHE qualifiers must equal 100.

---

**/SYSTEM\_NAME=*name***

Specifies the name to be assigned to the controller.

The name represents any-user defined phrase, up to 20 alphanumeric characters long.

---

**Note**

The /SYSTEM\_NAME qualifier is not supported for Smart Array controllers.

---

**/VERBOSE**

Provides logging that can be interpreted by engineering.

**Example**

```
MSA> SET GLOBALS/EXPAND PRIORITY=HIGH/REBUILD  
PRIORITY=HIGH/SYSTEM_NAME="XXX"/READ_CACHE=50/  
WRITE_CACHE=50
```

Example MSA\$UTIL response for SHOW GLOBALS:

```
Controller: _$1$GGA1002: (DEFAULT)  
Global Parameters:  
System Name: ITA8.2-1  
Rebuild Priority: high  
Expand Priority: low  
Total Cache: 256MB  
25% Read Cache: 64MB  
75% Write Cache: 192MB
```

## **SET UNIT**

Modifies the attributes of existing units.

### **Format**

SET UNIT <unit\_n> / <qualifiers> unit\_n

### **Parameters**

#### **unit\_n**

The unit number can be in the range of 0-31.

### **Qualifiers**

#### **/ADG**

Specifies that the RAID type for the existing unit is Advanced Data Guard (ADG). Use only with the /MIGRATE qualifier to migrate from any existing RAID level to ADG.

#### **/CACHE**

Specifies whether to use the controller's cache for the unit. Caching is On by default. To disable caching, use the /NOCACHE qualifier to the SET UNIT or ADD UNIT command.

#### **/DEL\_SPARE**

Specifies the spare disks to be removed from use for a unit. Multiple disks must be enclosed in parentheses. Use the following format:

```
/DEL_SPARE=(disk numbers[,...])
```

---

**Note**

---

If you delete a spare disk (that is assigned to more than one LUNs) from one unit, the disk specified in the DEL\_SPARE qualifier will be deleted from all the units in a disk group.

---

#### **/DISK**

Specifies the disks to be used to form the unit. Multiple disks must be enclosed in parentheses. Use only with the /EXPAND qualifier to expand the disks used by the existing unit, as shown in the following format:

```
/DISKS=(disk-numbers[,...])
```

---

**Note**

---

The /DISK qualifier can only be used with the /EXPAND qualifier.

---

#### **/EXPAND**

Allows the specified logical unit and all units in the disk/disk group to utilize more disks. The /EXPAND qualifier does not increase the size of the logical unit; rather, it adds more disks and increases space on individual disks.



To increase the size of the logical unit use the /EXTEND qualifier after you expand the unit.

During expansion of units in a drive group, the RAID level of certain units might change. For example, if a RAID 1 unit with 2 disks is expanded to 3 disks, then the RAID level must change to RAID 5 because the RAID 1 unit does not support an odd number of disks.

When you expand a unit with other units present on the same set of drives, all units undergo volume expansion. Use the following format:

```
SET UNIT <unit_n>/EXPAND/DISKS=<disk range>
```

---

**Note**

---

The value for disk range must include both pre-expansion disks and the additional disks, for example 101, (101,112,314, ...).

Only the /DISK qualifier should be used with the /EXPAND qualifier.

---



---

**Note**

---

The /EXTEND, /EXPAND, and /MIGRATE qualifiers can be used only with the SET UNIT command to change the attributes of an existing unit.

---

### **/EXTEND**

Increases the size of an existing logical unit. To specify a new size for the unit, use the /SIZE qualifier along with the /EXTEND qualifier. The size specified must be greater than the current unit size. When extending a unit with other units present on the same set of drives, some units might be moved (that is, undergo volume expansion) to make space for the additional size required.

Note that even though the SET UNIT/EXTEND command increases the unit size, you complete other command completing successfully, the increased size takes effect only after you complete other steps (such as SET VOLUME/EXTENSION) successfully at the DCL prompt. For more information, see the *HP OpenVMS System Manager's Volume 1: Essentials* manual.

Use the following format:

```
SET UNIT <unit_n> /EXTEND/SIZE=value
```

---

**Note**

---

The /EXTEND, /EXPAND, and /MIGRATE qualifiers can be used only with the SET UNIT command to change the attributes of an existing unit.

---

### **/IDENTIFIER**

Specifies the unit number to be used by OpenVMS. The value of the identifier is between 0 and 9999.

---

**Note**

---

The /IDENTIFIER qualifier is not required for Smart Array controllers.

---

## MSA Utility SET UNIT

### **/JBOD**

Specifies the RAID type to be JBOD. This is synonymous with RAID 0.

### **/MIGRATE**

Migrates the fault tolerance (RAID) level or stripe size, or both, of an existing logical unit. When migrating a unit with other units present on the same set of drives, some units might undergo volume expansion.

```
SET UNIT <unit_n>/MIGRATE [/RAID_LEVEL=R] [/STRIPE_SIZE=S]
```

where *unit\_n* = (0-31), R=(0,1,5), and S =(8,16,32,64,128,256)

---

#### **Note**

---

The /ADG or /JBOD qualifier can also be used instead of the /RAID\_LEVEL qualifier.

Only RAID level and stripe size can be modified using the /MIGRATE qualifier.

Cannot migrate any RAID units (RAID 1, RAID 5 and so on) that have spare disks to RAID 0 or JBOD units.

---

#### **Note**

---

The /EXTEND, /EXPAND, and /MIGRATE qualifiers can be used only with the SET UNIT command to change the attributes of an existing unit.

### **/RAID\_LEVEL=level**

Specifies the RAID type of the unit. The supported values for this qualifier are 0 (data stripe), 1 (disk memory), and 5 (data striping with striped parity).

---

#### **Note**

---

The /RAID\_LEVEL qualifier can be used only with the /MIGRATE qualifier.

See the following example for the correct format:

```
/RAID_LEVEL=[ ( 0 | 1 | 5 ) ]
```

### **/SIZE=size**

Specifies the new size of a unit.

Use the following format:

```
/SIZE=size (GB | MB | KB | %)
```

---

#### **Note**

---

The /SIZE qualifier can only be used with the /EXTEND qualifier.

**/SPARE**

/SPARE specifies the disks to be designated as the spare disks. Multiple disks must be enclosed in parentheses. Assigning a spare disk to an unit in a drive group will assign the spare disk to all the configured units in the drive group. If an unit is created on a disk group to which a spare disk is assigned, then the spare disk will be configured to the new unit (if it is not a RAID 0 unit). One spare disk can be assigned to multiple drive groups. Ensure that the size of the spare disk is at least equal to the size of the smallest drive in the drive group.

See the following example for the correct format:

```
/SPARE=(disk_number[,...])
```

**/STRIPE\_SIZE=size**

Specifies the new stripe size for a given RAID volume. Stripe size must be one of the following values: 8, 16, 32, 64, 128, and 256. Raid 5 and ADG are limited to a maximum 64 KB stripes.

---

**Note**

---

The /STRIPE\_SIZE qualifier can be used only with the /MIGRATE qualifier.

---

**/VERBOSE**

Provides logging that can be interpreted by engineering.

## Restrictions

The following restrictions are there for the MSA utility SET UNIT command:

- The /RAID\_LEVEL and /STRIPE\_SIZE qualifiers can be used only with the /MIGRATE qualifier.
- The /DISK qualifier can be used only with the /EXPAND qualifier.
- The /SIZE qualifier can be used only with the /EXTEND qualifier.

---

**Note**

---

The /EXTEND, /EXPAND, and /MIGRATE qualifiers can be used only with SET UNIT command to change the attributes of an existing unit.

---

## Examples

1. MSA> SET UNIT 0/CACHE

This command modifies unit 0 and enables the use of the array accelerator for unit 0.

2. SET UNIT 0/EXPAND/DISK=(0,1,2,3)

This command increases the number of disks used by unit 0 and all the other units on the disk group.

## MSA Utility SET UNIT

3. MSA> SET UNIT 0/SPARE=(100,101)

This command specifies that unit 0 and all the other units on the disk group are spares.

4. MSA> SET UNIT 0/MIGRATE/RAID\_LEVEL=1/STRIPE\_SIZE=64

This command migrates the RAID level and the stripe size to 64 KB.

5. MSA> SET UNIT 0/EXTEND/SIZE=6GB

This command increases the size of Unit 0. The other units on the disk group may go into volume expansion state.

---

### Note

---

The size of a UNIT cannot be decreased using the SET UNIT command.

---

6. MSA> SET UNIT 0/ID=100

This command sets the identifier for unit 0 to 100.

7. MSA> SET UNIT 0/DEL\_SPARE=(1,2)

If unit 0 has spare disks 1, 2, and 3, then this command removes the disks 1 and 2 from the spare disk list. Hence, unit 0 will have only disk 3 as spare disk.

8. MSA> SET UNIT 0/DEL\_SPARE=(1,2,3)

If unit 0 has spare disks 1, 2, and 3, then this command removes all the specified disks 1, 2 and 3 from the spare disk list in a disk group.

---

## SHOW CONNECTIONS

### Format

SHOW CONNECTIONS / <qualifiers>

Displays the worldwide name, connection name, and profile of each host bus adapter (HBA) attached to the controller. If connections between the HBAs and the MSA utility have been given user-defined names, these names are also displayed.

---

#### Note

---

The SHOW CONNECTIONS command is applicable only to the MSA utility and not Smart Array controllers.

Use the SHOW CONNECTIONS command to verify that all connections to the MSA utility are recognized and defined.

---

### Parameters

None

### Qualifiers

#### **/VERBOSE**

Provides logging that can be interpreted by engineering.

### Example

```
MSA> SHOW CONNECTIONS
Connection Name: abc
Host WWNN = 50060b00-001d25b5
Host WWPN = 50060b00-001d25b4
Profile Name = Default
Unit Offset = 0
Controller 1 Port 1 Status = Online
Controller 2 Port 1 Status = Online
```

This command shows the name of a specific connection to display.

## MSA Utility

### SHOW CONTROLLER

---

#### SHOW CONTROLLER

Displays information about the specified controller. If the controller name is not provided, then information of all the connected controllers is displayed.

The SHOW CONTROLLER command is synonymous with the SHOW ADAPTER command.

---

#### Note

---

If the context is set to a specific controller and the controller name is not provided, then SHOW CONTROLLER displays information about only the controller to which the context is set.

---

#### Format

SHOW CONTROLLER (controller\_name:) / <qualifiers> controller\_name:

#### Parameters

**controller\_name:**

#### Qualifiers

##### **/BUS**

Displays the bus number of the controller.

##### **/BRIEF**

Displays limited information about the controller.

##### **/DEFAULT**

Displays information about the default controller.

##### **/NODEFAULT**

Displays information about all the controllers.

##### **/FULL**

Displays extensive information about the controller.

##### **/REVISION**

Displays the firmware version of the controller, along with the default information for the controller.

##### **/SUBSYSTEM**

Displays the subsystem ID of the controller.

##### **/VERBOSE**

Provides logging that can be interpreted by engineering.

## Example

```
MSA> SHOW CONTROLLER

A default controller is not set. All matching controllers
displayed

Controller: _$1$GGA201:
MSA1000      (c) COMPAQ      P56350B9IN2021 Software 4.42
Controller Identifier: 201
NODE_ID = 500805f3-0001b660
SCSI_VERSION = SCSI-3
Supported Redundancy Mode: Active/Standby
Current Redundancy mode: Active/Standby
Current Role: Standby
Device Port SCSI address 6
Host Port 1:
    REPORTED PORT_ID = 500805f3-0001b669
    PORT_1_TOPOLOGY = Not available to this program
Cache:
    102 megabyte read cache  154 megabyte write cache
    Cache is GOOD, and Cache is enabled.
    No unflushed data in cache.
Battery:
    Battery is fully charged.

Controller: _$1$GGA300:
MSA CONTROLLER (c) HP      P56350GX3QN152 Software 6.72
Controller Identifier: 300
NODE_ID = 500508b3-00905ed0
SCSI_VERSION = SCSI-3
Supported Redundancy Mode: Asym Active/Active Active/Standby
    Current Redundancy mode: Asymmetrical Active/Active
    Current Role: Active
    Device Port SCSI address 7
Host Port 1:
    REPORTED PORT_ID = 500508b3-00905ed1
    PORT_1_TOPOLOGY = Not available to this program
Cache:
    128 megabyte read cache  128 megabyte write cache
    Cache is GOOD, and Cache is enabled.
    No unflushed data in cache.
Battery:
    Battery is fully charged.

Controller: _$1$GGA301:
MSA CONTROLLER (c) HP      P56350GX3QN0FS Software 6.72
Controller Identifier: 301
NODE_ID = 500508b3-00905ed0
SCSI_VERSION = SCSI-3
Supported Redundancy Mode: Asym Active/Active Active/Standby
    Current Redundancy mode: Asymmetrical Active/Active
    Current Role: Active
    Device Port SCSI address 6
Host Port 1:
    REPORTED PORT ID = 500508b3-00905ed9
    PORT_1_TOPOLOGY = Not available to this program
Cache:
    128 megabyte read cache  128 megabyte write cache
    Cache is GOOD, and Cache is enabled.
    No unflushed data in cache.
Battery:
    Battery is fully charged.
```

## MSA Utility

### SHOW CONTROLLER

```
Controller:  $1$GGA1002:
MSA1000      (c) COMPAQ      P56350A9IMN06M Software 4.42
Controller Identifier: 1002
NODE_ID = 500805f3-0001b660
SCSI_VERSION = SCSI-3
Supported Redundancy Mode: Active/Standby
  Current Redundancy mode: Active/Standby
  Current Role: Active
  Device Port SCSI address 7
Host Port 1:
  REPORTED PORT_ID = 500805f3-0001b661
  PORT_1_TOPOLOGY = Not available to this program
Cache:
  102 megabyte read cache  154 megabyte write cache
  Cache is GOOD, and Cache is enabled.
  No unflushed data in cache.
Battery:
  Battery is fully charged.

Adapter:  _PKD0:
SA6400      (c) HP      P57820FDAPHJE7 Software 1.92
SCSI_VERSION = X3.131:1994 (SCSI-2)
Not currently Redundant
Current Role: Active
(No redundant controller installed)
Cache:
  128 megabyte read/write cache
  Cache is not configured, and Cache is disabled.
  No unflushed data in cache.
Battery:
  Battery is not fully charged.

Adapter:  _PKE0:
SA6400 EM    (c) HP      P577C0EDAPH3JK Software 1.92
SCSI_VERSION = X3.131:1994 (SCSI-2)
Not currently Redundant
Current Role: Active
(No redundant controller installed)
Cache:
  128 megabyte read/write cache
  Cache is not configured, and Cache is disabled.
  No unflushed data in cache.
Battery:
  Battery is not fully charged.
```

This command displays information about all the controllers because a default controller has not been set.



---

## SHOW DISKS

Displays the following information on all available physical disks: disk number, enclosure bus number and ID, disk size, unit created on the disk, and disks assigned as spares.

---

### Note

SHOW DISK <disk\_n> can be used to view information of a particular disk, where disk\_n is the disk number. Disks are identified by their corresponding SCSI bus and SCSI IDs for all the controllers. For SAS controllers, internally connected disks are numbered based on their bay numbers and externally connected disks are numbered based on combination of their box number and bay number as "disk\_n" = box Number \*100 + bay number".

For the Smart Array P400 series of controllers, the target ID, connector, and bay are also displayed.

---

## Format

SHOW DISKS / <qualifiers>

## Parameters

None

## Qualifiers

### /AVAILABLE

Lists all the disks on which there are no units configured.

### /ENCLOSURE

Displays all the disks connected to a particular enclosure.

SHOW DISKS/ENCLOSURE = <enclosure\_n>

---

### Note

/ENCLOSURE qualifier is supported only for SAS controllers.

---

### /FULL

Displays the drive model and the drive serial number in addition to the disk information.

---

### Note

For the Smart Array P400 series of controllers, the following information is displayed:

## MSA Utility SHOW DISKS

Connector Location  
Connector  
Enclosure  
Bay  
WWID  
Device Type  
Disk Capacity  
Device Status  
Device Vendor ID  
Device Product ID  
Device Serial Number  
Device Firmware Version  
Reserved Area (cfg/status information)  
Block Size (bytes/sector)  
M&P Data Stamped  
Last Failure Reason  
Physical Disk Flags

---

### **/MEMBER**

Displays the disks on which the units are configured.

### **/SPARE**

Displays the disks that are configured as spares for logical units.

### **/VERBOSE**

Provides logging that can be interpreted by engineering.

## Examples

1. MSA> SHOW DISKS

This command displays information about all available disks.

2. MSA> SHOW DISK/SPARE  
MSA> SHOW DISK/AVAILABLE

These commands display information about designated spare disks and all available disks on which no units are configured.

3. MSA> SHOW DISK 1

For SAS controllers, the output of SHOW DISK command will be similar to the following:

```
SAS device           [Disk]
Disk 1: bus: 1, Target id: 7, Port: 3I,
Box/Enclosure: 1, Bay: 1,
size 68.37 [73.41]GB
Disk 1, # 0, size 14329984 blocks,
(6.83 [7.34] GB), Unit 3.
Disk 1, # 1, size 128979218 blocks,
(61.50 [66.04] GB), Unused.
MSA>
```

4. MSA> SHOW DISK 201

For SATA controllers, the output of SHOW DISK command will be similar to the following:

```
SATA device                [Disk]
Disk 201: bus: 1, Target id: 8, Port: 2E,
Box/Enclosure: 2, Bay: 1,
size 149.05 [160.04]GB
Disk 201, # 0, size 312516272 blocks,
(149.02 [160.01] GB), Unused.
MSA>
```

5. MSA> SHOW DISK 201

For all other controllers, the output of SHOW DISK command will be similar to the following:

```
SAS device                  [Disk]
Disk 9: bus: 1, Target id: 9, Port: 1E,
Box/Enclosure: 2, Bay: 5, size 68.37 [73.41]GB
Disk 9, # 0, size 2096640 blocks,
(1023.75 [1073.48] MB), Unit 1.
Disk 9, # 1, size 1397664 blocks,
(682.45 [715.60] MB), Unit 2.
Disk 9, # 2, size 1044256 blocks,
(509.89 [534.66] MB), Unit 3.
Disk 9, # 3, size 1048320 blocks,
(511.88 [536.74] MB), Unit 4.
Disk 9, # 4, size 13772322 blocks,
(65.67 [70.51] GB), Unused.
MSA>
```

6. MSA> SHOW DISKS/ENCLOSURE

## MSA Utility

### SHOW GLOBALS

---

### SHOW GLOBALS

Displays the following global parameters for the specified controller: system name, rebuild and expand-priority settings, and read and write cache settings.

#### Format

SHOW GLOBALS / <qualifiers>

#### Parameters

None

#### Qualifiers

##### **/BRIEF**

Displays the global parameters information about the controller.

##### **/FULL**

Displays the WWID information in addition to the global parameters.

##### **/VERBOSE**

Provides logging that can be interpreted by engineering.

#### Examples

1. MSA> SHOW GLOBALS  
Global Parameters:  
System Name: ABC  
Rebuild Priority: high  
Expand Priority: high  
Total Cache: 256MB  
50% Read Cache: 128 MB  
50% Write Cache: 128 MB

This command displays the global parameters for the controller.

2. MSA> SHOW GLOBALS/FULL  
MSA> SHOW GLOBALS/BRIEF

These commands display the WWID parameters and the global parameters for the controller.

## SHOW PROFILE

Displays all the profile names.

### Format

```
SHOW PROFILE [profile_name] / <qualifiers> profile_name
```

### Parameters

**profile\_name**

Displays the specified profile name.

### Qualifiers

**/VERBOSE**

Provides logging that can be interpreted by engineering.

### Example

```
MSA> SHOW PROFILE
```

This command displays all profile names.

## MSA Utility

### SHOW OTHER\_CONTROLLER

---

### SHOW OTHER\_CONTROLLER

Display information about the controller. The state of this controller can be either ACTIVE or STANDBY.

This is not supported on Smart Array controllers.

#### Format

SHOW OTHER\_CONTROLLER

## **SHOW THIS\_CONTROLLER**

Displays information about the controller to which the context is set. The state of this controller can be either ACTIVE or STANDBY.

This command applies to both Smart Array and MSA1000/MSA1500 series of controllers.

### **Format**

SHOW THIS\_CONTROLLER

## MSA Utility SHOW UNIT

---

### SHOW UNIT

Displays the following information for the specified unit:

- Unit identifier (user-defined name)
- Unit status
- List of the disks assigned as data disks to the UNIT
- List of the disks assigned as spares to the UNIT
- RAID level
- Unit size

### Format

SHOW UNIT



---

## SHOW UNITS

Displays information about all the logical volumes configured on the controller.

---

### Note

---

From the command-line interface of MSA1000/MSA1500 controllers, if ACLs are enabled for the units with respect to the connections (HBAs to which these controllers are connected), then only those corresponding UNITS are visible to the respective HBAs.

---

After the ACLs are enabled, if you create any units on these controllers (from either CLI or MSA\$UTIL), then you must set the ACLs explicitly in order for these units to be visible.

### Format

```
SHOW UNITS <unit_n> / <qualifiers> unit_n
```

### Parameters

#### **unit\_n**

The unit number can range from 0 to 31.

### Qualifiers

#### **/BRIEF**

Displays information about the unit.

#### **/FULL**

Displays the physical configuration information of the unit in addition to the unit information.

#### **/VERBOSE**

Provides logging that can be interpreted by engineering.

### Example

```
MSA> SHOW UNIT 0/FULL
MSA> SHOW UNIT 1/BRIEF
```

These commands display the physical configuration of the unit as well as the unit information.

## MSA Utility

### SHOW VERSION

---

#### SHOW VERSION

Displays the MSA\$UTIL version number.

#### Format

SHOW VERSION / <qualifiers>

#### Parameters

None

#### Qualifiers

##### **/FULL**

Displays the WWID, firmware version, and controller revision information in addition to the MSA\$UTIL version.

##### **/VERBOSE**

Provides logging that can be interpreted by engineering.

#### Example

```
MSA> SHOW VERSION/FULL
```

This command displays displays the WWID, firmware version, controller revision information, and the MSA\$UTIL version.

---

## START RECOVER

Initiates the REBUILD operation for all the units configured in the disk group sequentially.

Note that "hiding" the insertion of a new disk from the controller can result in the rebuild operation not starting automatically, even if the controller can detect hot-plug events (such as when connected to an MSA30). Removing a disk while the host system is running, and replacing the disk while the host system is powered off, effectively hides the insertion. The START RECOVER command initiates the rebuild operation in such scenarios also.

This command is supported on both OpenVMS Alpha and OpenVMS Integrity server platforms.

---

**Note**

---

For additional information about rebuilding volumes, see the SCAN ALL command.

---

### Format

START RECOVER

### Parameters

None

### Qualifiers

None



---

## Point-to-Point Utility

### 3.1 PPPD Description

The Point-to-Point Protocol utility (PPPD) initiates and manages a Point-to-Point Protocol (PPP) network connection and its link parameters from an OpenVMS Alpha or Integrity host server. This chapter describes the PPPD commands, with their parameters and qualifiers, that support PPP connections.

For information about the PPP driver and its programming interface, see the files `PPP_INTERFACES.TXT` and `PPP_INTERFACES.PS` in `SYS$SYSROOT:[SYSHLP.EXAMPLES.PPPD.DOC]`.

### 3.2 PPPD Usage Summary

The Point-to-Point Protocol utility (PPPD) allows you to initiate and control a Point-to-Point Protocol (PPP)-compliant network connection from an OpenVMS Alpha or Integrity servers host and define its physical link parameters.

Specifically, you can use this utility to:

- Create an asynchronous (ASN) device. PPPD creates the device automatically if one is not currently associated with a serial port (such as TTA1).
- Set both PPP and ASN device characteristics such as flow control and baud rate.
- Inform the network stacks that there is a new physical transport that uses the PPP.
- Act as a simple terminal emulator when establishing a connection to a new system (asynchronous only).
- Display configuration information about the ASN and PPP device drivers as well as any ongoing PPPD sessions.

#### Format

```
$ PPPD
```

The utility then displays the following prompt:

```
PPPD>
```

#### Description

After invoking PPPD, you can perform PPPD operations by entering the appropriate commands. You can also enter a single PPPD command on the same line as the command that invokes the utility, for example:

```
$ PPPD CONNECT TTAO:
```

## PPPD

### 3.2 PPPD Usage Summary

To exit from the Point-to-Point Protocol utility, enter the **EXIT** command at the **PPPD>** prompt or press **Ctrl/Z**. Either method returns control to the **DCL** command level.

For information about the PPPD utility, enter the **HELP** command at the **PPPD>** prompt.

### 3.3 PPPD Commands

This section describes and provides examples of the PPPD commands. If you need to customize your PPP settings, command qualifiers are provided. However, most users will be satisfied with the default settings.

Table 3–1 summarizes the PPPD command functions.

**Table 3–1 PPPD Command Summary**

| <b>Command</b> | <b>Function</b>  |
|----------------|--|
| CONNECT        | Establishes a network connection through the current physical port or a specified remote port. |
| DIAL_OUT       | Allows direct access to a device to dial out over a modem or link to an external device.       |
| DISCONNECT     | Terminates the network connection and returns control to the terminal driver.                  |
| EXIT           | Leaves the utility and returns you to the DCL command prompt (\$).                             |
| HELP           | Displays help text for PPPD commands.  |
| SET            | Determines the device and line characteristics for the specified terminal.                     |
| SHOW           | Displays the device and line characteristics of the specified terminal.                        |

---

## CONNECT

Establishes a network connection to a device located on the current physical port or specified remote port.

### Format

```
CONNECT device-name[:]
```

#### Parameter

##### device-name[:]

Optional. Supplies the name of a device through which the network connection is made. The device name has the form *ddcu* where *dd* is the device code, *c* is the controller designation, and *u* is the unit number. LAN devices are specified as the name of the device that is unit 0. For example, the first terminal device on a LAN is specified as TTA0, the second as TTb0.

#### Qualifiers

None.

### Description

The CONNECT command creates a link, or connection, to the device located on the current physical port or a specific remote port. When you enter this command, control passes to the PPP driver and an incoming transient network session is established. When the session is disconnected, the control of the host device returns to the terminal device driver.

#### Example

```
PPPD> CONNECT TTA1:
%PPPD-I-CONNECTTERM, converting connection on device _TTA1: to a
Point-to-Point connection
```

The command in this example creates a temporary network connection to the serial port TTA1. The port is ready to receive the PPP setup negotiations initiated by the host at the other end of the serial connection.

---

## DIAL\_OUT

Provides access to a specific physical device to dial a modem or link to an external device.

### Format

DIAL\_OUT device-name[:]

#### Parameter

##### **device-name[:]**

Supplies the name of a device over which the network connection is made. The device name has the form *ddcu* where *dd* is the device code, *c* is the controller designation, and *u* is the unit number. LAN devices are specified as the name of the device that is unit 0. For example, the first terminal device on a LAN is specified as TTA0, the second as TTb0.

#### Qualifiers

##### **/BREAK=*break-character***

Specifies a character sequence that you can use to interrupt the signal being currently transmitted. To interrupt the signal, type *Ctrl/break-character*. You can select any ASCII character from @ through Z, except C, M, Q, S, and Y. The default break character is ~.

##### **/DISCONNECT=*disconnect-character***

Specifies a character sequence that you can use to terminate DIAL\_OUT mode. To disconnect the call, type *Ctrl/disconnect-character*. You can select any ASCII character from @ through Z, except C, M, Q, S, and Y. The default disconnect character is \.

##### **/SWITCH=*switch-character***

Specifies a character sequence that you can use to switch the line to PPP mode. To activate PPP mode, type *Ctrl/switch-character*. You can select any ASCII character from @ through Z, except C, M, Q, S, and Y. The default switch character is @.

Similar to the CONNECT command, this qualifier switches a line into PPP mode. If the packet negotiations fail, PPPD exits and the line is left in terminal mode. If line is set to /MODEM and /NOHANGUP, this can result in extraneous data, the ASCII representation of Internet Protocol (IP) packets, being transmitted across the open line.

### Description

The DIAL\_OUT command directs access to a specific physical device to dial a modem or access an external device.



### Example

```
PPPD> DIAL_OUT TTA0:
Type control-~ to send a break,
      control-\ to disconnect,
      and control-@ to switch to a point-to-point connection.

UNIVRS - Unauthorized access is prohibited
Username:  SEBASTIAN
Password:

      Welcome to OpenVMS (TM) Alpha Operating System, Version 7.3-1 on node UNIVRS
      Last interactive login on Tuesday, AUGUST 13, 2000 02:39 PM
      Last non-interactive login on Monday, AUGUST 12, 2000 02:16 PM

$ PPPD CONNECT
%PPPD-I-CONNECTTERM, converting connection on device _TTB0: to a
Point-to-Point connection
Ctrl-@

%PPPD-I-CONNECTTERM, converting connection on device _TTA1: to a
Point-to-Point connection
```

This example illustrates using PPP with a direct serial link.

## PPPD DISCONNECT

---

### DISCONNECT

Terminates the current network connection.

#### Format

```
DISCONNECT device-name[:]
```

##### Parameter

##### **device-name[:]**

Optional. Indicates the name of a device over which the network connection occurred. The device name has the form *ddcu* where *dd* is the device code, *c* is the controller designation, and *u* is the unit number. LAN devices are specified as the name of the device that is unit 0. For example, the first terminal device on a LAN is specified as TTA0, the second as TTb0.

##### Qualifiers

None.

#### Description

The DISCONNECT command terminates the physical link to a network, independent of the state of the upper-level protocols. The physical device reverts to the appropriate terminal driver and the upper-level protocols receive a hang-up event. This command is often used to clear and reset port communication settings in the case of a system pause.

```
PPPD> DISCONNECT TTA1:
```

The command in this example terminates the current network connection established through the serial port TTA1.

---

#### Note

---

A user must have the same UIC as the one on the ASNn: device for the connection, or have SYSPRV privilege to disconnect a serial port.

---

---

## EXIT

Stops the execution of PPPD and returns control to the DCL command level. You can enter Ctrl/Z only if the line has not already been switched to PPP mode.

### Format

EXIT

#### Parameters

None.

#### Qualifiers

None.

### Description

Use the EXIT command to exit the utility.

```
PPPD> EXIT
```

The command in this example leaves the PPPD utility and returns control to the DCL command level.

## PPPD HELP

---

### HELP

Provides online help information for using the PPPD commands.

### Format

```
HELP [command-name...]
```

#### Parameter

##### **command-name**

The name of a PPPD command or PPPD command and command keyword. If you enter the HELP command with a command name only, such as HELP SET, PPPD displays a list of all of the command keywords used with the SET command.

### Description

The HELP command is an online reference for PPPD commands. After you view an initial help display, press Return. The help display stops and the PPPD prompt is displayed. If you do not specify a command name, the HELP command displays general information on the commands for which help is available. Supplying a command name obtains syntax information for that command.

```
PPPD> HELP DISCONNECT
```

In this example, the HELP DISCONNECT command produces a description of the DISCONNECT command and shows the command format.

---

## SET

Sets the communication line characteristics for a specific terminal device.

### Format

SET device-name[:]

#### Parameter

##### device-name

Indicates the name of the device whose characteristics are to be set. The device name has the form *ddcu* where *dd* is the device code, *c* is the controller designation, and *u* is the unit number. LAN devices are specified as the name of the device that is unit 0. For example, the first terminal device on a LAN is specified as TTA0, the second as TTb0.

#### Qualifiers

**/ADDRESS\_COMPRESSION (default)**

**/NOADDRESS\_COMPRESSION**

Indicates whether the address and control fields are compressed.

**/CLEAR\_COUNTERS=(keyword,...)**

Determines which counters to clear when trying to resolve performance problems. The default is to clear all counters. With this qualifier, you can specify one or more of the following keywords:

| Keyword             | Description   |
|---------------------|---|
| ALL                 | Resets all counters.  |
| BAD_FCS_PACKETS     | Resets the count of packets with a bad frame check sequence (FCS).                      |
| DATA_LOST           | Resets the count of lost characters that were reported by hardware.                     |
| DROPPED_CHARACTERS  | Resets the count of all characters thrown away.   |
| FRAMING_ERRORS      | Resets the count of characters with framing errors.                                     |
| LONG_PACKETS        | Resets the count of packets longer than the current maximum receive unit (MRU) setting. |
| RECEIVED_PACKETS    | Resets the count of total packets received.   |
| RUNT_PACKETS        | Resets the count of packets with too few characters.                                    |
| TOTAL_CHARACTERS    | Resets the count of all characters received.  |
| TRANSMITTED_PACKETS | Resets the count of total packets transmitted.  |

#### **/CONNECT**

Sets the line parameters and binds the ASN device to the physical terminal.

**/ECHO=(FAILURE=*value*, INTERVAL=*value*)**

Specifies the number of Link Control Protocol (LCP) echo requests and the interval between requests that must be sent without response before the line is considered down. The default number of echo requests is 0.

***/FLOW\_CONTROL=control-option***

Indicates the type of flow control used over the physical link. You can specify one of the following keywords with this qualifier:

| Keyword               | Description  |
|-----------------------|--|
| HARDWARE              | Uses RTS/CTS flow control. If using this control, the transmit Asynch Control Character Map (ACCM) can be 0x0, 0x0, 0x0, 0x60000000. Only valid for lines set to /MODEM or /COMMSYNCH. |
| XON_XOFF<br>(default) | Uses band flow control. If using this control, the optimal transmit ACCM is 0xA0000, 0x0, 0x0, 0x60000000. Only valid for asynchronous lines.  |

***/HANGUP***

***/NOHANGUP***

Determines the action that occurs when a session is terminated. This qualifier notifies the ASN driver when a modem hangup is necessary due to an idle device. For example, when the last network connection is closed on a transient line that is set to /NOHANGUP, the line switches back to the terminal driver but the modem remains connected. This allows users to reaccess the line and log in without having to redial and reestablish the connection.

To use this qualifier, you must have PHY\_IO privilege, or the line must have TT2\$M\_MODHANGUP already set.

***/MAGIC\_NUMBER\_RETRIES=value***

Specifies the number of attempts made to negotiate a magic number. Magic numbers are used to detect looped back connections. If you specify 0, no negotiations are made. If you specify 255, negotiation continues until a number is found. The default number of attempts is 5.

***/MAXCONFIGURE=value***

Indicates the number of configure-request packets sent without receiving a valid configure-ack, configure-nak, or configure-reject before assuming the peer is unable to respond. Specify a value in the range of 0 to 255. The default number of packets sent is 10.

***/MAXFAILURE=value***

Indicates the number of configure-nak packets sent without receiving a valid configure-ack before assuming that the configuration is not converging. Specify a value in the range of 0 to 255. The default number of packets sent is 5.

***/MAXTERMINATE=value***

Indicates the number of terminate-request packets sent without receiving a terminate-ack before assuming that the peer is unable to respond. Specify a value in the range of 0 to 255. The default number of packets is 2.

***/MRU=size***

Specifies the largest packet that can be received over the line. This value is used as part of the line negotiation, and the actual MRU setting can vary. Specify a value in the range of 6 to 1500. The default packet size is 1500.

***/MTU=size***

Specifies the largest packet that can be transmitted over the line. This value is used as part of the line negotiation, and the actual maximum transfer unit (MTU)

setting can vary. Specify a value in the range of 6 to 1500. The default packet size is 1500.

**/NETWORK\_PROTOCOL=(protocol-name)**

Specifies the the protocol allowed over the link. The default network protocol is TCP/IP.

**/PASSIVE**

**/NOPASSIVE (default)**

Notifies the PPP driver how to handle the PPP connection. It can either actively initiate the connection or wait for the remote host to start the connection.

**/PERMANENT**

**/NOPERMANENT**

Determines how the link is handled when a connection is closed or lost. If you specify **/PERMANENT**, the link remains in place with the PPP driver in control. If you specify **/NOPERMANENT**, the link is treated as a transient connection, and the terminal reverts to the terminal driver.

**/PROTOCOL\_COMPRESSION (default)**

**/NOPROTOCOL\_COMPRESSION**

Specifies whether the two octet protocol fields are compressed into a single octet.

**/RECEIVE\_ACCM=*mask-value***

Identifies the starting Asynch Control Character Map (ACCM). This mask is used by the PPP driver to negotiate the final ACCM for asynchronous ports. Specify a mask in the range of 0x0 to 0xFFFFFFFF. The default mask value is 0xFFFFFFFF, 0x0, 0x0, 0x60000000, 0x0, 0x0, 0x0. The masks are ordered from low-order longword to high-order longword. Specify the longword mask until the last mask bits are set. The remaining longwords are set to 0. With 8 longwords, there is 1 bit for every ASCII character position (from 0 to 255). The ASCII characters 0x20 through 0x3F and 0x5E cannot be quoted.

**/RESTART\_TIMER=*msecs***

Interval in milliseconds (msecs) used to time the transmission of configure-request and terminate-request packets. Expiration of the restart timer results in a timeout event and retransmission of the packet. Specify a value from 1 to 90. The default is 30 milliseconds (.03 seconds), which is intended for relatively slow speed links. For smaller, faster links, specify a smaller value.

**/SPEED=(*input-rate,output-rate*)**

Allows you to control the input and output speed of the line for asynchronous ports. To use this qualifier, you must have PHY\_IO privilege, or the line must already have TT2\$M\_SETSPEED set.

Specify one of the following speeds: 50, 75, 100, 134, 150, 300, 600, 1200, 1800, 2400, 3600, 4800, 7200, 9600, 19200, 38400, 57600, 76800, or 115200. If your line allows split speed, you can specify different speeds for input and output. If you only specify one speed, it is used for both input and output.

**/TRANSMIT\_ACCM=*mask-value,...***

Identifies the starting Asynch Control Character Map (ACCM). This mask is used by the PPP driver to negotiate the final transmit ACCM for asynchronous ports. Specify a mask in the range of 0x0 to 0xFFFFFFFF. The default mask value is 0xFFFFFFFF, 0x0, 0x0, 0x60000000, 0x0, 0x0, 0x0. The masks are ordered from low-order longword to high-order longword. Specify the longword mask until the

## PPPD SET

last mask bits are set. The remaining longwords are set to 0. With 8 longwords, there is 1 bit for every ASCII character position (from 0 to 255). The ASCII characters 0x20 through 0x3F and 0x5E cannot be quoted.

### Description

Use the SET command to specify the communications characteristic of a terminal device. Communications characteristics such as address compression, flow control, and line speed determine how data is transmitted and received. These characteristics take effect as soon as you invoke the CONNECT or DIAL\_OUT command.

---

#### Note

---

If you you invoke a SET command from the DCL command line (for example, PPPD SET/MTU=1000 tta0), the utility assumes you wish to connect and attempt to start a PPP connection on the specified device.

---

```
PPPD> SET/PERMANENT TTA0:  
%PPPD-I-CONNECTTERM, converting connection on device _TTA0: to a  
Point-to-Point connection
```

In this example, the SET command is setting up a permanent network connection over the serial port TTA0.



---

## SHOW

Allows you to display the communication characteristics for a specific terminal.

### Format

SHOW device-name[:]

#### Parameter

##### device-name[:]

Supplies the name of the device whose characteristics are to be displayed. The device name has the form *ddcu* where *dd* is the device code, *c* is the controller designation, and *u* is the unit number. LAN devices are specified as the name of the device that is unit 0. For example, the first terminal device on a LAN is specified as TTA0, the second as TTb0.

#### Qualifiers

##### /ADDRESS\_COMPRESSION

Indicates whether the address compression is on or off.

##### /ALL[=BRIEF] (default)

##### /ALL[=LONG]

Displays all the current device and communication settings. BRIEF formats the output for the screen. LONG displays each setting on a separate line.

##### /COUNTERS=(keyword,...)

Shows the current values for the specified counter(s). You can specify one or more of the following keywords with this qualifier:

| Keyword             | Description   |
|---------------------|---|
| ALL                 | Displays all counters.  |
| BAD_FCS_PACKETS     | Displays the count of packets with bad frame check sequence (FCS).                        |
| DATA_LOST           | Displays the count of lost characters that were reported by hardware.                     |
| DROPPED_CHARACTERS  | Displays the count of all characters thrown away.   |
| FRAMING_ERRORS      | Displays the count of characters with framing errors.                                     |
| LONG_PACKETS        | Displays the count of packets longer than the current maximum receive unit setting (MRU). |
| RECEIVED_PACKETS    | Displays the count of total packets received.   |
| RUNT_PACKETS        | Displays the count of packets with too few characters.                                    |
| TOTAL_CHARACTERS    | Displays the count of all characters received.  |
| TRANSMITTED_PACKETS | Displays the count of total packets transmitted.  |

##### /ECHO=(FAILURE=value, INTERVAL=value)

Specifies the number of Link Control Protocol (LCP) echo requests and the interval (in milliseconds) between requests that must be sent without response before the line is considered down.

##### /FCS\_SIZE

Shows the current receive and transmit FCS size in bits.

## PPPD SHOW

### **/FLOW\_CONTROL=(keyword,...)**

Shows the current flow control setting used over the asynchronous physical link. You can specify one of the following keywords with this qualifier:

| Keyword               | Description  |
|-----------------------|--|
| HARDWARE              | Uses RTS/CTS flow control. If using this control, the transmit Asynch Control Character Map (ACCM) can be 0x0, 0x0, 0x0, 0x60000000. Only valid for lines set to /MODEM or /COMMSYNCH. |
| XON_XOFF<br>(default) | Uses band flow control. If using this control, the optimal transmit ACCM is 0xA0000, 0x0, 0x0, 0x60000000. Only valid for asynchronous lines.  |

### **/HANGUP**

Displays the action that occurs when a session is terminated.

### **/MAGIC\_NUMBER\_RETRIES**

Shows the number of attempts that are made to negotiate a magic number.

### **/MAXCONFIGURE**

Shows the number of configure-request packets sent without acknowledgment before assuming that the peer is not responding.

### **/MAXFAILURE**

Displays the number of configure-nak packets sent before sending a configure-ack and before assuming that the configuration is not converging.

### **/MAXTERMINATE**

Shows the number of terminate-request packets sent without acknowledgment before assuming the peer is unable to respond.

### **/MRU**

Displays the largest packet that the line can receive.

### **/MTU**

Displays the largest packet that the line can transmit.

### **/NETWORK\_PROTOCOL**

Displays the current network protocol(s) allowed over the physical link.

### **/PASSIVE**

Indicates whether this is a passive or active line.

### **/PERMANENT**

Indicates whether this is a permanent or transient (nonpermanent) line.

### **/PROTOCOL\_COMPRESSION**

Shows the status of protocol field compression.

### **/RECEIVE\_ACCM**

Displays the value of the current receive ACCM for asynchronous ports.

### **/RESTART\_TIMER**

Displays the interval used to time transmission of request packets.

### **/SPEED**

Indicates the current input and output speeds of the line.

**/TRANSMIT\_ACCM**

Displays the value of the current transmit ACCM for asynchronous ports.

**Description**

The SHOW command allows you display the current terminal and communication settings. To display all available settings, use the /ALL qualifier.

```

PPPD> SHOW/ALL=BRIEF TTA0:
Line TTA1: is being used for PPP connections

Debug trace:      OFF      Debug mailbox:
Address comp:    OFF      Max configure:      10  Restart timer:      30
ASN port name:  ASN13    Max failure:        5
Echo failure:    0        Max terminate:      2  Receive ACCM:      FFFFFFFF
Echo intervals:  0        MRU:                1500  Transmit ACCM:     FFFFFFFF
Flow control:    XON/XOFF  MTU:                1500
Hangup:         DEFAULT  Mode:               ACTIVE  00000000
Line type:      TRANSIENT  Net protocol:      TCP/IP  60000000
Magic retries:  0        Protocol comp:     OFF    00000000
Input speed:    DEFAULT  Receive FCS:       16    00000000
Output speed:   DEFAULT  Transmit FCS:      16

```

Counter totals for line TTA0:

```

Bad FCS packets:      0  Packets received:      4
Data lost (chars):    0  Packets transmitted:   6
Dropped chars:       0  Runt packets:          0
Framing errors:      0  Total chars received: 179
Long packets:        0

```

The command in this example displays the current PPP characteristics assigned to port TTA1.



---

# POLYCENTER Software Installation Utility (PCSI)

## 4.1 PRODUCT Introduction

The DCL interface to the POLYCENTER Software Installation utility (PCSI) is the `PRODUCT` command.

PCSI creates, installs, and manages software products. You can use it to do the following:

- Install and reconfigure software products.
- Remove software products.
- Display information from the software product database, such as the names of installed products, the names of patches applied, product dependencies, the names of files provided by product, and historical information about past operations.
- Locate software product kits.
- Create a software product kit in sequential, compressed, or reference format.
- List the contents of a software product kit or extract files from the kit, such as release notes or files you specify.
- Perform other operations such as establishing default configuration choices offered by a product, copying a product kit or converting it to a different format, and registering information about a product in the product database.
- Uninstall the last patch or set of patches applied to a product.

### Format

```
PRODUCT [subcommand product-name [/qualifiers]]
```

### Description

To use PCSI from the DCL prompt, enter the `PRODUCT` command, a subcommand, and any required parameters and optional qualifiers. For example:

```
$ PRODUCT INSTALL FORTRAN /VERSION=V7.2-3 /SOURCE=DISK1:[KITS]
```

This command installs FORTRAN V7.2-3 on your system from a product kit located in `DISK1:[KITS]`.

## 4.1 PRODUCT Introduction

### Parameters

#### subcommand

Specifies an operation you want PCSI to perform. If you do not supply a subcommand, the utility prompts you to select one from a list.

#### product-name

Specifies the name of the product to which you want to apply the activity. Some subcommands do not require this parameter. You can use the asterisk (\*) and the percent sign (%) wildcard characters for all or part of the *product-name*. You can specify a list of products separated by commas (,).

The product name is the same as the third component of the file name of the product kit. For example, the product name parameter that you would use to refer to a kit named DEC-AXPVMS-FORTRAN-V0702-3-1.PCSI is FORTRAN. A product name can include an underscore character (\_) but never a hyphen (-). For example, VMS73\_DRIVER is the name of a remedial kit for OpenVMS whose file name is DEC-AXPVMS-VMS73\_DRIVER-V0300-4.PCSI.

## 4.2 PRODUCT Commands

The following table describes PRODUCT subcommands:

| Subcommand            | Description   |
|-----------------------|---|
| ANALYZE PDB           | Verifies the product database and makes minor repairs, if possible.   |
| CONFIGURE             | Creates a product configuration file (PCF).   |
| COPY                  | Copies a software product kit or converts it to another format such as compressed format.                                     |
| DELETE RECOVERY_DATA  | Deletes one or more patch recovery data sets.   |
| EXTRACT FILE          | Retrieves a specified file or files from a software product kit.  |
| EXTRACT PDF           | Retrieves the product description file (PDF) from a software product kit.   |
| EXTRACT PTF           | Retrieves the product text file (PTF) from a software product kit.  |
| EXTRACT RELEASE_NOTES | Retrieves the release notes from a software product kit.  |
| FIND                  | Displays the name of product kits found in a specified directory.   |
| INSTALL               | Installs one or more software products and updates the product database.  |
| LIST                  | Lists the files contained in a software product kit   |
| PACKAGE               | Creates a software product kit in either sequential or reference format.  |
| RECONFIGURE           | Modifies the configuration of an installed product and updates the product database.  |
| REGISTER PRODUCT      | Records information in the product database about one or more installed products that are not yet registered in the database. |

---

| <b>Subcommand</b>  | <b>Description</b>   |
|--------------------|--|
| REGISTER VOLUME    | Records a change in volume label in the product database.                        |
| REMOVE             | Uninstalls one or more software products and updates the product database.       |
| SHOW HISTORY       | Displays in chronological order the operations performed on software products.   |
| SHOW OBJECT        | Displays information about objects created during software product installation. |
| SHOW PRODUCT       | Displays information about installed products.                                   |
| SHOW RECOVERY_DATA | Displays patch recovery data sets in chronological order.                        |
| SHOW UTILITY       | Displays version information about PCSI.   |
| UNDO PATCH         | Uninstalls one or more patches for which recovery data has been saved.           |

---

# PCSI ANALYZE PDB

---

## ANALYZE PDB

Verifies the structural integrity of the product database and, in some circumstances, performs minor repairs on the files in the database.

### Format

PRODUCT ANALYZE PDB [/qualifiers]

### Description

The product database refers to an interrelated set of files named \*.PCSI\$DATABASE. These files ordinarily reside in SYS\$SYSTEM.

When you use this command, PCSI does the following:

- Reads \*.PCSI\$DATABASE files referenced by the root database file PCSI\$ROOT.PCSI\$DATABASE and checks all fields for correct syntax.
- Automatically performs minor repairs when a known corruption pattern can be identified and if a repair is feasible.
- Provides instructions for rebuilding the database if an unrecoverable corruption is found.

The PRODUCT ANALYZE PDB command always reads the PCSI\$ROOT.PCSI\$DATABASE file, even if you also select a subset of the database files for analysis.

### Parameters

None.

### Qualifiers

#### **/LOCATION=device-name:[directory-name]**

Specifies the location of the product database files to be analyzed. Include only a device and directory name. This qualifier is useful if you copy the product database to a temporary directory to perform verification and repair on the copy rather than on the original files.

If you do not use this qualifier, the default location of the product database files is SYS\$SYSDEVICE:[VMS\$COMMON.SYSEXE]. If you omit the device name, PCSI uses your current default device. If you omit the directory name, PCSI uses your current default directory.

#### **/PDB\_TYPE=keyword**

Specifies that a subset of the product database files is to be analyzed. By default, all database files referenced by the root database file PCSI\$ROOT.PCSI\$DATABASE are analyzed.

Keywords are as follows:

|             |   |
|-------------|---|
| FILE_SYSTEM | Selects the PCSI\$FILE_SYSTEM.PCSI\$DATABASE file for analysis. |
| PROCESSOR   | Selects the PCSI\$PROCESSOR.PCSI\$DATABASE file for analysis.   |



**PRODUCT**=(product-name[,...])      Selects the product specific database files for the named products for analysis. Wildcard characters are permitted in the product name.

**ROOT**      Selects the PCSI\$ROOT.PCSI\$DATABASE file for analysis.

**/REMOTE**

**/NOREMOTE (default)**

Selects the product database located on a privately mounted system disk. By default, PCSI searches the currently booted system disk for the product database.

When you use /REMOTE, the following logical names must be defined:

- PCSI\$SYSDEVICE must specify the physical disk name of the target system disk. This disk must be mounted and allocated to the process executing the PRODUCT command.
- PCSI\$SPECIFIC must point to a system root on PCSI\$SYSDEVICE. It must be defined in the following form, where *x* is a valid system root:

PCSI\$SYSDEVICE:[SYS*x*.]

## Examples

1. \$ PRODUCT ANALYZE PDB

Analyzing product database files in DISK\$V83SYS:[VMS\$COMMON.][SYSEXE]

```
...scanned PCSI$ROOT.PCSI$DATABASE;1
...scanned PCSI$FILE SYSTEM.PCSI$DATABASE;1
...scanned PCSI$PROCESSOR.PCSI$DATABASE;1
...scanned DEC-AXPVMS-DECNET_OSI-V0703-2.PCSI$DATABASE;1
...
...scanned DEC-AXPVMS-VMS-V0803-2.PCSI$DATABASE;1
```

Completed product database analysis with no errors detected

The command in this example verifies the active product database files in their usual location on the system disk in SYS\$SYSTEM.

2. \$ PRODUCT ANALYZE PDB /LOCATION=DKA300:[TEST] /PDB\_TYPE=PRODUCT=TCP/IP\*)

Analyzing product database files in DKA300:[TEST]

```
...scanned DEC-AXPVMS-TCP/IP-V0504-15.PCSI$DATABASE;1
...scanned DEC-AXPVMS-TCP/IP_ECO-V0504-155.PCSI$DATABASE;1
...scanned DEC-AXPVMS-TCP/IP_ECO-V0504-154.PCSI$DATABASE;1
...scanned DEC-AXPVMS-TCP/IP_ECO-V0504-152.PCSI$DATABASE;1
```

Completed product database analysis with no errors detected

The command in this example analyzes the database files in the DKA300:[TEST] directory for the TCP/IP product and all the patch kits that have been applied to it. The root database file PCSI\$ROOT.PCSI\$DATABASE must also be in this directory.

---

## CONFIGURE

Creates a product configuration file (PCF) for one or more products. Optionally uses the values in an existing PCF file to create the new PCF.

### Format

PRODUCT CONFIGURE product-name[...] [/qualifiers]

### Parameter

**product-name**

Names the product, or list of products, for which product configuration files will be generated.

### Qualifiers

**/BASE\_SYSTEM=base-system-name**

Selects software products whose base system matches the one specified. The base system name identifies both a hardware platform and an operating system. Standard names are:

| Name   | Description  |
|--------|--|
| AXPVMS | Denotes an OpenVMS Alpha product.  |
| I64VMS | Denotes an OpenVMS Integrity servers product.                                |
| VAXVMS | Denotes an OpenVMS VAX product.  |
| VMS    | Indicates a product that can be installed on more than one OpenVMS platform. |

**/CONFIGURATION=(keyword[,...])**

Specifies how the configuration choices are used. Keywords are:

|                 |   |
|-----------------|---|
| CURRENT         | Uses values from the product database. These values are the configuration choices made when the product was installed or reconfigured.  |
| PRODUCER        | Uses values specified by the software manufacturer of the product.  |
| INPUT=pcf-name  | Uses values from the specified product configuration file.  |
| OUTPUT=pcf-name | Writes configuration choices to the specified product configuration file. If no file name is supplied, creates a file named DEFAULT.PCSI\$CONFIGURATION in the current default directory. |

The keywords CURRENT, PRODUCER, and INPUT are mutually exclusive. (CURRENT is the default if none of these keywords is specified.)

The OUTPUT keyword can be used with the CURRENT, PRODUCER, or INPUT keyword.

If you specify only one keyword, you can omit the parentheses.

**/HELP**

**/NOHELP (default)**

Controls whether detailed explanations of product options and informational text are displayed. The first time you install a product, these explanations can help you decide which options to select. When you perform subsequent installations or upgrades, you might choose the brief explanations to save time.

When /NOHELP is selected, you can request a detailed explanation about a question by performing one of the following actions at the prompt:

- Press the Help key or PF2 key
- Type ? and press the Return key

**/KIT\_ATTRIBUTES=keyword([,...])**

Selects kits by kit type or kit format, or both. Keywords are:

**FORMAT=**                      Designates the format of the product kit as follows:  
format-type

- |            |  |
|------------|--|
| COMPRESSED | Compressed format in which a data compression technique has been applied to a sequential kit. A compressed kit has a .PCSI\$COMPRESSED file type.            |
| REFERENCE  | Reference format in which product files exist in a directory tree. A .PCSI\$DESCRIPTION file in the top level of the directory tree denotes a reference kit. |
| SEQUENTIAL | Sequential format in which product files are placed in a container file. A file type of .PCSI indicates a sequential kit.                                    |

**TYPE=**                              Specifies the type of product kit as follows:  
kit-type

- |                      |  |
|----------------------|--|
| FULL                 | Layered product (application) software.  |
| OPERATING_<br>SYSTEM | Operating system software.   |
| MANDATORY_<br>UPDATE | A required correction to currently installed software. Functionally, this type of kit is the same as a patch kit.  |
| PARTIAL              | An upgrade to currently installed software. Installation of this kit changes the version of the product.           |
| PATCH                | A correction to currently installed software. Installation of this kit does not change the version of the product. |
| PLATFORM             | An integrated set of software products (also called a product suite).  |

**/LOG**

**/NOLOG (default)**

Displays the file specification of the configuration file that is created.

## PCSI CONFIGURE

### **/OPTIONS=keyword**

### **/NOOPTIONS (default)**

Specifies PRODUCT command options. The keywords are:

**NOCONFIRM** Omits the confirmation dialog that asks the user to verify the products that have been selected for the operation.  
The NOCONFIRM and NODEFAULT\_KIT keywords are mutually exclusive.

**NODEFAULT\_KIT** Directs the utility to query the user instead of choosing a default kit when more than one kit that matches the selection criteria for the product is found in the source directory path. The selection criteria include the producer, base system, product name, and product version strings that are embedded in the file name of a kit.

If multiple kits are found for a selected product, and NODEFAULT\_KIT is not specified, the utility determines the default kit to use by applying the following rules:

1. The last character of the kit's file name (1-7) is used to order the kits by kit type. In descending order, the precedence is as follows: full, operating system, partial, patch, platform, transition, and mandatory update.
2. The file type is used to order the kits by format. In descending order, the precedence is as follows: compressed (.PCSI\$COMPRESSED), sequential (.PCSI), and reference (.PCSI\$DESCRIPTION).
3. If multiple kits are found with the same file name and file type, but differ in their directory path names, the case of their file specifications, or their file versions, then the first file found by RMS search rules takes precedence.

The NODEFAULT\_KIT and NOCONFIRM keywords are mutually exclusive.

**NOVALIDATE\_KIT** Disables validation of software product kits that are signed and have a manifest file in the source directory.

### **/PRODUCER=producer-name**

Selects software products that the specified manufacturer produces.

### **/REMOTE**

### **/NOREMOTE (default)**

Selects the product database located on a privately mounted system disk. By default, PCSI searches the currently booted system disk for the product database.

When you use /REMOTE, the following logical names must be defined:

- PCSI\$SYSDEVICE must specify the physical disk name of the target system disk. This disk must be mounted and allocated to the process executing the PRODUCT command.

- PCSI\$SPECIFIC must point to a system root on PCSI\$SYSDEVICE. It must be defined in the following form, where *x* is a valid system root:

```
PCSI$SYSDEVICE:[SYSx.]
```

**/SOURCE=device-name:[directory-name]**

Specifies the disk and directory where the utility searches for the software product kit or kits. If /SOURCE is not specified, the utility searches in the location defined by the logical name PCSI\$SOURCE. If PCSI\$SOURCE is not defined, and the /SOURCE qualifier is not specified, PCSI searches the current default directory.

**/SPAN\_VERSIONS=keyword([,...])**

Selects software products whose versions match the specified version criteria. The keywords are:

|                 |   |
|-----------------|---|
| ABOVE=version   | Selects versions greater than the version specified             |
| BELOW=version   | Selects versions less than the version specified                |
| MINIMUM=version | Selects versions greater than or equal to the version specified |
| MAXIMUM=version | Selects versions less than or equal to the version specified    |

The ABOVE, BELOW, MINIMUM, and MAXIMUM keywords can be used alone or in combination. For example, /SPAN\_VERSIONS= (MINIMUM=V2.1,BELOW=V3.0) selects versions greater than or equal to V2.1 and less than (but not including) V3.0. Using the MAXIMUM keyword instead of BELOW would select versions that include V3.0.

**/VERSION=version-number**

Selects software products that have the specified version.

**Example**

```
$ PRODUCT CONFIGURE EDITOR -
_$ /CONFIGURATION=(INPUT=EDITOR_REV1.PCF,OUTPUT=EDITOR_REV2.PCF)
```

The command in this example reads an existing PCF file named EDITOR\_REV1.PCF for a product named EDITOR to obtain default values for its configuration options. Then a configuration dialog allows the user to change and review all options. Finally, the modified configuration values are saved in EDITOR\_REV2.PCF.

---

## COPY

Copies or converts one or more existing product kits that you specify to product kits in the format you request. For example, you can create a kit in reference format from a kit in sequential format, create a compressed kit from a kit in sequential format, or simply copy a kit to a new location without changing its format.

### Format

```
PRODUCT COPY product-name /DESTINATION=device-name:[directory-name]
              [qualifiers]
```

### Description

The PRODUCT COPY command allows you to compress a sequential kit. If you do not have a kit in sequential format, you must first use the PRODUCT PACKAGE command to create a sequential kit from the product materials. Then you can use the PRODUCT COPY command to convert it to compressed format. You cannot create a kit in compressed format directly from a kit in reference format.

Use the /FORMAT qualifier to determine the format of the product kits that you create. Use the /KIT\_ATTRIBUTES=FORMAT qualifier to select kits of a particular format to be copied or converted.

If you copy a product kit that is signed and has an associated manifest file in the source directory, both the kit and its manifest are copied to the destination directory. A manifest file is used for product kit validation. It must have a file name and file type that match the file specification of the product kit, with \_ESW appended to the file type.

### Parameter

**product-name**

Names the product, or list of products, to copy.

### Qualifiers

**/BASE\_SYSTEM=base-system-name**

Selects software products whose base system matches the one specified. The base system name identifies both a hardware platform and an operating system. Standard names are:

| Name   | Description  |
|--------|--|
| AXPVMS | Denotes an OpenVMS Alpha product.  |
| I64VMS | Denotes an OpenVMS Integrity servers product.                                |
| VAXVMS | Denotes an OpenVMS VAX product.  |
| VMS    | Indicates a product that can be installed on more than one OpenVMS platform. |

**/DESTINATION=device-name:[directory-name]**

Specifies the location where the utility will create the sequential or compressed kit. For a reference kit, specifies the top-level directory location where the utility will place files.

If you do not provide a device name, the default is the user's default device. If you omit the directory name, the default is the user's default directory.

The PRODUCT COPY command ignores the PCSI\$DESTINATION logical name whether or not you use the /DESTINATION qualifier.

**/FORMAT=keyword**

Specifies the output format of the product kit. Keywords are:

|            |   |
|------------|---|
| COMPRESSED | Compressed format in which a data compression technique is applied to a sequential kit to produce a .PCSI\$COMPRESSED file, which is the compressed form of a sequential kit.   |
| REFERENCE  | Reference format in which product files are placed in a directory tree for direct access. The utility creates a product description file, with a file type of .PCSI\$DESCRIPTION, in the top level of the directory tree. |
| SEQUENTIAL | Sequential format in which product files are placed in a container file having a .PCSI file type.   |

The default is to preserve the format of the product kit. You must use this qualifier if you want to change the format of the product kit.

**/KIT\_ATTRIBUTES=keyword([,...])**

Selects kits by kit type or kit format, or both. Keywords are:

|                        |  |
|------------------------|--|
| FORMAT=<br>format-type | Designates the format of the product kit as follows:   |
| COMPRESSED             | Compressed format in which a data compression technique has been applied to a sequential kit. A compressed kit has a .PCSI\$COMPRESSED file type.            |
| REFERENCE              | Reference format in which product files exist in a directory tree. A .PCSI\$DESCRIPTION file in the top level of the directory tree denotes a reference kit. |
| SEQUENTIAL             | Sequential format in which product files are placed in a container file. A file type of .PCSI indicates a sequential kit.                                    |

**TYPE=**  
**kit-type** Specifies the type of product kit as follows:

|                                    |  |
|------------------------------------|--|
| <b>FULL</b>                        | Layered product (application) software.  |
| <b>OPERATING_</b><br><b>SYSTEM</b> | Operating system software.   |
| <b>MANDATORY_</b><br><b>UPDATE</b> | A required correction to currently installed software. Functionally, this type of kit is the same as a patch kit.  |
| <b>PARTIAL</b>                     | An upgrade to currently installed software. Installation of this kit changes the version of the product.   |
| <b>PATCH</b>                       | A correction to currently installed software. Installation of this kit does not change the version of the product.   |
| <b>PLATFORM</b>                    | An integrated set of software products (also called a product suite).  |
| <b>TRANSITION</b>                  | Used to register information about a product that is installed but not recorded in the product database (for example, a product installed by VMSINSTAL). This kit does not provide product material. |

**/LOG**

**/NOLOG (default)**

Displays the file specification of the product kit file that is created and the files packaged in the kit.

**/OPTIONS=keyword**

**/NOOPTIONS (default)**

Specifies PRODUCT command options. The keywords are:

**NOCONFIRM** Omits the confirmation dialog that asks the user to verify the products that have been selected for the operation.  
The **NOCONFIRM** and **NODEFAULT\_KIT** keywords are mutually exclusive.



**NODEFAULT\_KIT** Directs the utility to query the user instead of choosing a default kit when more than one kit that matches the selection criteria for the product is found in the source directory path. The selection criteria include the producer, base system, product name, and product version strings that are embedded in the file name of a kit.

If multiple kits are found for a selected product, and **NODEFAULT\_KIT** is not specified, the utility determines the default kit to use by applying the following rules:

1. The last character of the kit's file name (1-7) is used to order the kits by kit type. In descending order, the precedence is as follows: full, operating system, partial, patch, platform, transition, and mandatory update.
2. The file type is used to order the kits by format. In descending order, the precedence is as follows: compressed (.PCSI\$COMPRESSED), sequential (.PCSI), and reference (.PCSI\$DESCRIPTION).
3. If multiple kits are found with the same file name and file type, but differ in their directory path names, the case of their file specifications, or their file versions, then the first file found by RMS search rules takes precedence.

The **NODEFAULT\_KIT** and **NOCONFIRM** keywords are mutually exclusive.

**NOVALIDATE\_KIT** Disables validation of software product kits that are signed and have a manifest file in the source directory.

**/OWNER\_UIC=uic**

Specifies the owner user identification code (UIC) for files created during a copy operation. By default, the user executing the operation owns the software product files. For example, if you are logged in to your own account, you can use this qualifier during a copy operation to assign ownership of the product files to **SYSTEM** rather than to your own account. Specify the UIC in alphanumeric format (in the form [name]) or in octal group-member format (in the form [g,m]). UIC formats are described in the *OpenVMS User's Manual*.

**/PRODUCER=producer-name**

Selects software products that the specified manufacturer produces.

**/SOURCE=device-name:[directory-name]**

Specifies the disk and directory where the utility searches for the software product kit or kits. If **/SOURCE** is not specified, the utility searches in the location defined by the logical name **PCSI\$SOURCE**. If **PCSI\$SOURCE** is not defined, and the **/SOURCE** qualifier is not specified, **PCSI** searches the current default directory.

## PCSI COPY

### **/SPAN\_VERSIONS=keyword([,...])**

Selects software products whose versions match the specified version criteria.

The keywords are:

|                 |   |
|-----------------|---|
| ABOVE=version   | Selects versions greater than the version specified             |
| BELOW=version   | Selects versions less than the version specified                |
| MINIMUM=version | Selects versions greater than or equal to the version specified |
| MAXIMUM=version | Selects versions less than or equal to the version specified    |

The ABOVE, BELOW, MINIMUM, and MAXIMUM keywords can be used alone or in combination. For example, /SPAN\_VERSIONS= (MINIMUM=V2.1,BELOW=V3.0) selects versions greater than or equal to V2.1 and less than (but not including) V3.0. Using the MAXIMUM keyword instead of BELOW would select versions that include V3.0.

### **/VERSION=version-number**

Selects software products that have the specified version.

## Example

```
$ PRODUCT COPY ABC /SOURCE=[SHERMAN.ABC] -  
_ $ /DESTINATION=[KITS] /FORMAT=SEQUENTIAL
```

The command in this example converts product kit ABC, located in the [SHERMAN.ABC] directory on the user's default device, to a sequential copy in the [KITS] directory on the user's default device.

## DELETE RECOVERY\_DATA

Deletes one or more patch recovery data sets in order of creation date, starting with the oldest one first. A recovery data set is created when a patch kit is successfully installed with the /SAVE\_RECOVERY\_DATA qualifier. Recovery data sets are used to uninstall patches when you use the PRODUCT UNDO PATCH command.

Note that once patch recovery data is deleted, you cannot uninstall any patch that is associated with this data. Installed patches are not affected when you use the PRODUCT DELETE RECOVERY\_DATA command.

### Format

```
PRODUCT DELETE RECOVERY_DATA [/qualifiers]
```

### Parameters

None.

### Qualifiers

#### **/ALL (default)**

Selects all patch recovery data sets to be deleted. The recovery data is deleted in the order it was created, starting with the oldest set first. If you omit this qualifier from the command line, the effect is the same as if you specified it.

#### **/BEFORE=time**

Selects patch recovery data sets created before the specified date and time. You can specify time as an absolute time, as a combination of absolute and delta times, or as one of the following keywords:

```
TODAY (default)
TOMORROW
YESTERDAY
```

For information about specifying time values, see the *OpenVMS User's Manual*.

#### **/OPTIONS=keyword**

#### **/NOOPTIONS (default)**

Specifies PRODUCT command options. The keyword is:

|           |   |
|-----------|---|
| NOCONFIRM | Omits the confirmation dialog that asks the user to verify the recovery data sets that have been selected for processing. |
|-----------|---|

#### **/LOG**

#### **/NOLOG (default)**

Displays the file specifications of the files within the recovery data sets that are being deleted.

#### **/OLDEST=count**

Specifies the number of oldest recovery data sets that you want to delete. For example, if you specify /OLDEST=2, the PRODUCT DELETE RECOVERY\_DATA command deletes the two oldest recovery data sets. If you do not specify a number with this qualifier, the default value is 1.

## PCSI DELETE RECOVERY\_DATA

### **/REMOTE**

### **/NOREMOTE (default)**

Selects recovery data sets located on a privately mounted system disk. By default, PCSI searches the currently booted system disk for recovery data sets.

When you use /REMOTE, the following logical names must be defined:

- PCSI\$SYSDEVICE must specify the physical disk name of the target system disk. This disk must be mounted and allocated to the process executing the PRODUCT command.
- PCSI\$SPECIFIC must point to a system root on PCSI\$SYSDEVICE. It must be defined in the following form, where *x* is a valid system root:

```
PCSI$SYSDEVICE:[SYSx.]
```

## Example

```
$ PRODUCT DELETE RECOVERY_DATA /OLDEST=2
```

The command in this example deletes the two oldest recovery data sets starting with the one that was created first, followed by next oldest recovery data set. If, for example, three patch recovery data sets are on the system disk, you still have one set preserved after this operation completes.

Remember that once a patch recovery data set is deleted, you cannot uninstall the patch kit associated with the deleted recovery data. The installed patch kits, however, are not affected by this action.

---

## EXTRACT FILE

Retrieves a user-specified file or files from a software product kit. The original name of the file is preserved when it is extracted.

### Format

PRODUCT EXTRACT FILE product-name[,...] [/qualifiers]

### Parameter

#### **product-name**

Names the product, or list of products, from whose kits the selected file or files are to be retrieved. This parameter is required.

### Qualifiers

#### **/BASE\_SYSTEM=base-system-name**

Selects software products whose base system matches the one specified. The base system name identifies both a hardware platform and an operating system. Standard names are:

| Name   | Description  |
|--------|--|
| AXPVMS | Denotes an OpenVMS Alpha product.  |
| I64VMS | Denotes an OpenVMS Integrity servers product.                                |
| VAXVMS | Denotes an OpenVMS VAX product.  |
| VMS    | Indicates a product that can be installed on more than one OpenVMS platform. |

#### **/DESTINATION=device-name:[directory-name]**

Specifies the location where the utility will place all of the files that the user indicates are to be retrieved. If the device name is not provided, the default is the user's default device. If the directory name is omitted, or the /DESTINATION qualifier is not specified, the default is the user's default directory. The PRODUCT EXTRACT FILE command ignores the PCSI\$DESTINATION logical name whether or not you use the /DESTINATION qualifier.

#### **/KIT\_ATTRIBUTES=keyword([,...])**

Selects kits by kit type or kit format, or both. Keywords are:

## PCSI EXTRACT FILE

|                        |  |
|------------------------|--|
| FORMAT=<br>format-type | Designates the format of the product kit as follows:   |
| COMPRESSED             | Compressed format in which a data compression technique has been applied to a sequential kit. A compressed kit has a .PCSI\$COMPRESSED file type.  |
| REFERENCE              | Reference format in which product files exist in a directory tree. A .PCSI\$DESCRIPTION file in the top level of the directory tree denotes a reference kit.   |
| SEQUENTIAL             | Sequential format in which product files are placed in a container file. A file type of .PCSI indicates a sequential kit.  |
| TYPE=<br>kit-type      | Specifies the type of product kit as follows:  |
| FULL                   | Layered product (application) software.  |
| OPERATING_<br>SYSTEM   | Operating system software.   |
| MANDATORY_<br>UPDATE   | A required correction to currently installed software. Functionally, this type of kit is the same as a patch kit.  |
| PARTIAL                | An upgrade to currently installed software. Installation of this kit changes the version of the product.   |
| PATCH                  | A correction to currently installed software. Installation of this kit does not change the version of the product.   |
| PLATFORM               | An integrated set of software products (also called a product suite).  |
| TRANSITION             | Used to register information about a product that is installed but not recorded in the product database (for example, a product installed by VMSINSTAL). This kit does not provide product material. |

### **/LOG**

#### **/NOLOG (default)**

Displays the file specifications of the files that are extracted from the kit.

### **/OPTIONS=keyword**

#### **/NOOPTIONS (default)**

Specifies PRODUCT command options. The keywords are:

|           |  |
|-----------|--|
| NOCONFIRM | Omits the confirmation dialog that asks the user to verify the products that have been selected for the operation.<br>The NOCONFIRM and NODEFAULT_KIT keywords are mutually exclusive. |
|-----------|--|

**NODEFAULT\_KIT** Directs the utility to query the user instead of choosing a default kit when more than one kit that matches the selection criteria for the product is found in the source directory path. The selection criteria include the producer, base system, product name, and product version strings that are embedded in the file name of a kit.

If multiple kits are found for a selected product, and **NODEFAULT\_KIT** is not specified, the utility determines the default kit to use by applying the following rules:

1. The last character of the kit's file name (1-7) is used to order the kits by kit type. In descending order, the precedence is as follows: full, operating system, partial, patch, platform, transition, and mandatory update.
2. The file type is used to order the kits by format. In descending order, the precedence is as follows: compressed (.PCSI\$COMPRESSED), sequential (.PCSI), and reference (.PCSI\$DESCRIPTION).
3. If multiple kits are found with the same file name and file type, but differ in their directory path names, the case of their file specifications, or their file versions, then the first file found by RMS search rules takes precedence.

The **NODEFAULT\_KIT** and **NOCONFIRM** keywords are mutually exclusive.

**NOVALIDATE\_KIT** Disables validation of software product kits that are signed and have a manifest file in the source directory.

**/PRODUCER=producer-name**

Selects software products that the specified manufacturer produces.

**/SELECT=filename[,...]**

Specifies the name of a file, or a list of files, to be extracted from the specified product kit. You can use the asterisk (\*) and the percent sign (%) wildcard characters for all or part of the file name. The file name can contain a directory specification that includes an ellipsis (...). If you omit this qualifier, all files will be extracted from the specified kit or kits.

**/SOURCE=device-name:[directory-name]**

Specifies the disk and directory where the utility searches for the software product kit or kits. If **/SOURCE** is not specified, the utility searches in the location that the logical name **PCSI\$SOURCE** defines. If **PCSI\$SOURCE** is not defined, and the **/SOURCE** qualifier is not specified, **PCSI** searches the current default directory.

**/SPAN\_VERSIONS=keyword([,...])**

Selects software products whose versions match the specified version criteria. The keywords are:

## PCSI EXTRACT FILE

|                 |   |
|-----------------|---|
| ABOVE=version   | Selects versions greater than the version specified             |
| BELOW=version   | Selects versions less than the version specified                |
| MINIMUM=version | Selects versions greater than or equal to the version specified |
| MAXIMUM=version | Selects versions less than or equal to the version specified    |

The ABOVE, BELOW, MINIMUM, and MAXIMUM keywords can be used alone or in combination. For example, /SPAN\_VERSIONS= (MINIMUM=V2.1,BELOW=V3.0) selects versions greater than or equal to V2.1 and less than (but not including) V3.0. Using the MAXIMUM keyword instead of BELOW would select versions that include V3.0.

### **/VERSION=version-number**

Selects software products that have the specified version.

## Example

```
$ PRODUCT EXTRACT FILE TEST /SELECT=TEST.EXE /SOURCE=[AL]
```

In this example, PCSI extracts the file TEST.EXE from the kit of the product TEST that is in the [AL] directory on the user's default disk. The extracted file TEST.EXE is placed in the user's current default directory.



## EXTRACT PDF

Retrieves the product description file (PDF) from a software product. The file type of the extracted PDF file is .PCSI\$DESCRIPTION.

You can obtain the PDF from the software product kit or, if the product is already installed, from the product database.

### Format

PRODUCT EXTRACT PDF product-name[...] [/qualifiers]

### Parameter

#### **product-name**

Names the product, or list of products, whose PDF file is to be retrieved from the kit.

### Qualifiers

#### **/BASE\_SYSTEM=base-system-name**

Selects software products whose base system matches the one specified. The base system name identifies both a hardware platform and an operating system. Standard names are:

| Name   | Description  |
|--------|--|
| AXPVMS | Denotes an OpenVMS Alpha product.  |
| I64VMS | Denotes an OpenVMS Integrity servers product.                                |
| VAXVMS | Denotes an OpenVMS VAX product.  |
| VMS    | Indicates a product that can be installed on more than one OpenVMS platform. |

#### **/DESTINATION=device-name:[directory-name]**

Specifies the location where the utility will place the extracted product description file (PDF). If the device name is not provided, the default is the user's default device. If the directory name is omitted, or the /DESTINATION qualifier is not specified, the default is the user's default directory. The PRODUCT EXTRACT PDF command ignores the PCSI\$DESTINATION logical name whether or not you use the /DESTINATION qualifier.

#### **/FROM=keyword**

Specifies whether the PDF is to be extracted from a product kit or from the product database if the product is already installed.

Keywords are the following:

|     |   |
|-----|---|
| KIT | Extract the PDF file from a product kit. This is the default.           |
| PDB | Extract the PDF file of an installed product from the product database. |

The /FROM=PDB and /SOURCE qualifiers are mutually exclusive.

**/KIT\_ATTRIBUTES=keyword([,...])**

Selects kits by kit type or kit format, or both. Keywords are:

|                               |  |
|-------------------------------|--|
| <b>FORMAT=</b><br>format-type | Designates the format of the product kit as follows:   |
|                               | <b>COMPRESSED</b> Compressed format in which a data compression technique has been applied to a sequential kit. A compressed kit has a .PCSI\$COMPRESSED file type.  |
|                               | <b>REFERENCE</b> Reference format in which product files exist in a directory tree. A .PCSI\$DESCRIPTION file in the top level of the directory tree denotes a reference kit.  |
|                               | <b>SEQUENTIAL</b> Sequential format in which product files are placed in a container file. A file type of .PCSI indicates a sequential kit.  |
| <b>TYPE=</b><br>kit-type      | Specifies the type of product kit as follows:  |
|                               | <b>FULL</b> Layered product (application) software.  |
|                               | <b>OPERATING_</b><br><b>SYSTEM</b> Operating system software.  |
|                               | <b>MANDATORY_</b><br><b>UPDATE</b> A required correction to currently installed software. Functionally, this type of kit is the same as a patch kit.   |
|                               | <b>PARTIAL</b> An upgrade to currently installed software. Installation of this kit changes the version of the product.  |
|                               | <b>PATCH</b> A correction to currently installed software. Installation of this kit does not change the version of the product.  |
|                               | <b>PLATFORM</b> An integrated set of software products (also called a product suite).  |
|                               | <b>TRANSITION</b> Used to register information about a product that is installed but not recorded in the product database (for example, a product installed by VMSINSTAL). This kit does not provide product material. |

**/LOG**

**/NOLOG (default)**

Displays the file specification of the product description file that is created.

**/OPTIONS=keyword**

**/NOOPTIONS (default)**

Specifies PRODUCT command options. The keywords are:

|                  |  |
|------------------|--|
| <b>NOCONFIRM</b> | Omits the confirmation dialog that asks the user to verify the products that have been selected for the operation.<br>The NOCONFIRM and NODEFAULT_KIT keywords are mutually exclusive. |
|------------------|--|

**NODEFAULT\_KIT** Directs the utility to query the user instead of choosing a default kit when more than one kit that matches the selection criteria for the product is found in the source directory path. The selection criteria include the producer, base system, product name, and product version strings that are embedded in the file name of a kit.

If multiple kits are found for a selected product, and **NODEFAULT\_KIT** is not specified, the utility determines the default kit to use by applying the following rules:

1. The last character of the kit's file name (1-7) is used to order the kits by kit type. In descending order, the precedence is as follows: full, operating system, partial, patch, platform, transition, and mandatory update.
2. The file type is used to order the kits by format. In descending order, the precedence is as follows: compressed (.PCSI\$COMPRESSED), sequential (.PCSI), and reference (.PCSI\$DESCRIPTION).
3. If multiple kits are found with the same file name and file type, but differ in their directory path names, the case of their file specifications, or their file versions, then the first file found by RMS search rules takes precedence.

The **NODEFAULT\_KIT** and **NOCONFIRM** keywords are mutually exclusive.

**NOVALIDATE\_KIT** Disables validation of software product kits that are signed and have a manifest file in the source directory.

**/PRODUCER=producer-name**

Selects software products that the specified manufacturer produces.

**/SOURCE=device-name:[directory-name]**

Specifies the disk and directory where the utility searches for the software product kit or kits. If **/SOURCE** is not specified, the utility searches in the location that the logical name **PCSI\$SOURCE** defines. If **PCSI\$SOURCE** is not defined, and the **/SOURCE** qualifier is not specified, **PCSI** searches the current default directory.

The **/SOURCE** and **/FROM=PDB** qualifiers are mutually exclusive.

**/SPAN\_VERSIONS=keyword([,...])**

Selects software products whose versions match the specified version criteria. The keywords are:

|                        |   |
|------------------------|---|
| <b>ABOVE=version</b>   | Selects versions greater than the version specified             |
| <b>BELOW=version</b>   | Selects versions less than the version specified                |
| <b>MINIMUM=version</b> | Selects versions greater than or equal to the version specified |

## PCSI EXTRACT PDF

**MAXIMUM=version**                      Selects versions less than or equal to the version specified

The ABOVE, BELOW, MINIMUM, and MAXIMUM keywords can be used alone or in combination. For example, /SPAN\_VERSIONS= (MINIMUM=V2.1,BELOW=V3.0) selects versions greater than or equal to V2.1 and less than (but not including) V3.0. Using the MAXIMUM keyword instead of BELOW would select versions that include V3.0.

**/VERSION=version-number**

Selects software products that have the specified version.

### Example

```
$ PRODUCT EXTRACT PDF TEST /SOURCE=[AL]
```

In this example, PCSI extracts the product description file (PDF) from the kit of the product TEST that is in the [AL] directory on the user's default disk and places it in the user's current default directory.

## EXTRACT PTF

Retrieves the product text file (PTF) from a software product kit. The PTF file is stored in a product kit as a text library file. The file type of the extracted PTF is .PCSI\$TLB. In addition, a text file version of this text library file is created with a file type of .PCSI\$TEXT.

### Format

PRODUCT EXTRACT PTF product-name[,...] [/qualifiers]

### Parameter

#### **product-name**

Names the product, or list of products, whose PTF file is to be retrieved from the kit.

### Qualifiers

#### **/BASE\_SYSTEM=base-system-name**

Selects software products whose base system matches the one specified. The base system name identifies both a hardware platform and an operating system. Standard names are:

| Name   | Description  |
|--------|--|
| AXPVMS | Denotes an OpenVMS Alpha product.  |
| I64VMS | Denotes an OpenVMS Integrity servers product.                                |
| VAXVMS | Denotes an OpenVMS VAX product.  |
| VMS    | Indicates a product that can be installed on more than one OpenVMS platform. |

#### **/DESTINATION=device-name:[directory-name]**

Specifies the location where the utility will place the extracted product text file (PTF). If the device name is not provided, the default is the user's default device. If the directory name is omitted, or the /DESTINATION qualifier is not specified, the default is the user's default directory. The PRODUCT EXTRACT PTF command ignores the PCSI\$DESTINATION logical name whether or not you use the /DESTINATION qualifier.

#### **/KIT\_ATTRIBUTES=keyword([,...])**

Selects kits by kit type or kit format, or both. Keywords are:

## PCSI EXTRACT PTF

|                        |  |
|------------------------|--|
| FORMAT=<br>format-type | Designates the format of the product kit as follows:   |
| COMPRESSED             | Compressed format in which a data compression technique has been applied to a sequential kit. A compressed kit has a .PCSI\$COMPRESSED file type.  |
| REFERENCE              | Reference format in which product files exist in a directory tree. A .PCSI\$DESCRIPTION file in the top level of the directory tree denotes a reference kit.   |
| SEQUENTIAL             | Sequential format in which product files are placed in a container file. A file type of .PCSI indicates a sequential kit.  |
| TYPE=<br>kit-type      | Specifies the type of product kit as follows:  |
| FULL                   | Layered product (application) software.  |
| OPERATING_<br>SYSTEM   | Operating system software.   |
| MANDATORY_<br>UPDATE   | A required correction to currently installed software. Functionally, this type of kit is the same as a patch kit.  |
| PARTIAL                | An upgrade to currently installed software. Installation of this kit changes the version of the product.   |
| PATCH                  | A correction to currently installed software. Installation of this kit does not change the version of the product.   |
| PLATFORM               | An integrated set of software products (also called a product suite).  |
| TRANSITION             | Used to register information about a product that is installed but not recorded in the product database (for example, a product installed by VMSINSTAL). This kit does not provide product material. |

### **/LOG**

#### **/NOLOG (default)**

Displays the file specifications of the product text and product text library files that are created.

### **/OPTIONS=keyword**

#### **/NOOPTIONS (default)**

Specifies PRODUCT command options. The keywords are:

|           |  |
|-----------|--|
| NOCONFIRM | Omits the confirmation dialog that asks the user to verify the products that have been selected for the operation.<br>The NOCONFIRM and NODEFAULT_KIT keywords are mutually exclusive. |
|-----------|--|

**NODEFAULT\_KIT** Directs the utility to query the user instead of choosing a default kit when more than one kit that matches the selection criteria for the product is found in the source directory path. The selection criteria include the producer, base system, product name, and product version strings that are embedded in the file name of a kit.

If multiple kits are found for a selected product, and NODEFAULT\_KIT is not specified, the utility determines the default kit to use by applying the following rules:

1. The last character of the kit's file name (1-7) is used to order the kits by kit type. In descending order, the precedence is as follows: full, operating system, partial, patch, platform, transition, and mandatory update.
2. The file type is used to order the kits by format. In descending order, the precedence is as follows: compressed (.PCSI\$COMPRESSED), sequential (.PCSI), and reference (.PCSI\$DESCRIPTION).
3. If multiple kits are found with the same file name and file type, but differ in their directory path names, the case of their file specifications, or their file versions, then the first file found by RMS search rules takes precedence.

The NODEFAULT\_KIT and NOCONFIRM keywords are mutually exclusive.

**NOVALIDATE\_KIT** Disables validation of software product kits that are signed and have a manifest file in the source directory.

**/PRODUCER=producer-name**

Selects software products that the specified manufacturer produces.

**/SOURCE=device-name:[directory-name]**

Specifies the disk and directory where the utility searches for the software product kit or kits. If /SOURCE is not specified, the utility searches in the location that the logical name PCSI\$SOURCE defines. If PCSI\$SOURCE is not defined, and the /SOURCE qualifier is not specified, PCSI searches the current default directory.

**/SPAN\_VERSIONS=keyword([,...])**

Selects software products whose versions match the specified version criteria. The keywords are:

|                 |   |
|-----------------|---|
| ABOVE=version   | Selects versions greater than the version specified             |
| BELOW=version   | Selects versions less than the version specified                |
| MINIMUM=version | Selects versions greater than or equal to the version specified |
| MAXIMUM=version | Selects versions less than or equal to the version specified    |

## PCSI EXTRACT PTF

The ABOVE, BELOW, MINIMUM, and MAXIMUM keywords can be used alone or in combination. For example, /SPAN\_VERSIONS= (MINIMUM=V2.1,BELOW=V3.0) selects versions greater than or equal to V2.1 and less than (but not including) V3.0. Using the MAXIMUM keyword instead of BELOW would select versions that include V3.0.

### **/VERSION=version-number**

Selects software products that have the specified version.

## Example

```
$ PRODUCT EXTRACT PTF TEST /SOURCE=[AL]
```

In this example, PCSI extracts the product text file (PTF) from the kit of the product TEST that is in the [AL] directory on the user's default disk and places two files in the user's current default directory: the extracted text library file (.PCSI\$TLB) and a text file (.PCSI\$TEXT) created from the library.



## EXTRACT RELEASE\_NOTES

Retrieves the release notes for the selected product or group of products. The name of each release notes file is preserved unless you override it with the /FILE qualifier.

### Format

PRODUCT EXTRACT RELEASE\_NOTES product-name[...] [/qualifiers]

### Parameter

#### **product-name**

Names the product, or list of products, from which to extract release notes.

### Qualifiers

#### **/BASE\_SYSTEM=base-system-name**

Selects software products whose base system matches the one specified. The base system name identifies both a hardware platform and an operating system. Standard names are:

| Name   | Description  |
|--------|--|
| AXPVMS | Denotes an OpenVMS Alpha product.  |
| I64VMS | Denotes an OpenVMS Integrity servers product.                                |
| VAXVMS | Denotes an OpenVMS VAX product.  |
| VMS    | Indicates a product that can be installed on more than one OpenVMS platform. |

#### **/DESTINATION=device-name:[directory-name]**

Specifies the location where the utility will place the extracted release notes files. If the device name is not provided, the default is the user's default device. If the directory name is omitted, or the /DESTINATION qualifier is not specified, the default is the user's default directory.

The PRODUCT EXTRACT RELEASE\_NOTES command ignores the PCSI\$DESTINATION logical name whether or not you use the /DESTINATION qualifier.

The /DESTINATION and /FILE qualifiers are mutually exclusive.

#### **/FILE=filespec**

Specifies the name of the output file that will contain the release notes. If no file name is given, the original name of the release notes file is preserved and the file is written to your default directory.

The /FILE qualifier has been superseded by /DESTINATION. HP recommends that you use /DESTINATION in command procedures and operator instructions. See the description of /DESTINATION for more information.

The /FILE and /DESTINATION qualifiers are mutually exclusive.

## PCSI EXTRACT RELEASE\_NOTES

### **/KIT\_ATTRIBUTES=keyword([,...])**

Selects kits by kit type or kit format, or both. Keywords are:

|                               |   |
|-------------------------------|---|
| <b>FORMAT=</b><br>format-type | Designates the format of the product kit as follows:  |
|                               | <b>COMPRESSED</b> Compressed format in which a data compression technique has been applied to a sequential kit. A compressed kit has a .PCSI\$COMPRESSED file type.           |
|                               | <b>REFERENCE</b> Reference format in which product files exist in a directory tree. A .PCSI\$DESCRIPTION file in the top level of the directory tree denotes a reference kit. |
|                               | <b>SEQUENTIAL</b> Sequential format in which product files are placed in a container file. A file type of .PCSI indicates a sequential kit.                                   |
| <b>TYPE=</b><br>kit-type      | Specifies the type of product kit as follows:   |
|                               | <b>FULL</b> Layered product (application) software.   |
|                               | <b>OPERATING_</b><br><b>SYSTEM</b> Operating system software.   |
|                               | <b>MANDATORY_</b><br><b>UPDATE</b> A required correction to currently installed software. Functionally, this type of kit is the same as a patch kit.                          |
|                               | <b>PARTIAL</b> An upgrade to currently installed software. Installation of this kit changes the version of the product.   |
|                               | <b>PATCH</b> A correction to currently installed software. Installation of this kit does not change the version of the product.   |
|                               | <b>PLATFORM</b> An integrated set of software products (also called a product suite).   |

### **/LOG**

#### **/NOLOG (default)**

Displays the file specification of the release notes file that is created.

### **/OPTIONS=keyword**

#### **/NOOPTIONS (default)**

Specifies PRODUCT command options. The keywords are:

|                  |  |
|------------------|--|
| <b>NOCONFIRM</b> | Omits the confirmation dialog that asks the user to verify the products that have been selected for the operation.<br>The NOCONFIRM and NODEFAULT_KIT keywords are mutually exclusive. |
|------------------|--|

**NODEFAULT\_KIT** Directs the utility to query the user instead of choosing a default kit when more than one kit that matches the selection criteria for the product is found in the source directory path. The selection criteria include the producer, base system, product name, and product version strings that are embedded in the file name of a kit.

If multiple kits are found for a selected product, and **NODEFAULT\_KIT** is not specified, the utility determines the default kit to use by applying the following rules:

1. The last character of the kit's file name (1-7) is used to order the kits by kit type. In descending order, the precedence is as follows: full, operating system, partial, patch, platform, transition, and mandatory update.
2. The file type is used to order the kits by format. In descending order, the precedence is as follows: compressed (.PCSI\$COMPRESSED), sequential (.PCSI), and reference (.PCSI\$DESCRIPTION).
3. If multiple kits are found with the same file name and file type, but differ in their directory path names, the case of their file specifications, or their file versions, then the first file found by RMS search rules takes precedence.

The **NODEFAULT\_KIT** and **NOCONFIRM** keywords are mutually exclusive.

**NOVALIDATE\_KIT** Disables validation of software product kits that are signed and have a manifest file in the source directory.

**/PRODUCER=producer-name**

Selects software products that the specified manufacturer produces.

**/SOURCE=device-name:[directory-name]**

Specifies the disk and directory where the utility searches for the software product kit or kits. If **/SOURCE** is not specified, the utility searches in the location that the logical name **PCSI\$SOURCE** defines. If **PCSI\$SOURCE** is not defined, and the **/SOURCE** qualifier is not specified, **PCSI** searches the current default directory.

**/SPAN\_VERSIONS=keyword([,...])**

Selects software products whose versions match the specified version criteria. The keywords are:

|                        |   |
|------------------------|---|
| <b>ABOVE=version</b>   | Selects versions greater than the version specified             |
| <b>BELOW=version</b>   | Selects versions less than the version specified                |
| <b>MINIMUM=version</b> | Selects versions greater than or equal to the version specified |
| <b>MAXIMUM=version</b> | Selects versions less than or equal to the version specified    |

## PCSI EXTRACT RELEASE\_NOTES

The ABOVE, BELOW, MINIMUM, and MAXIMUM keywords can be used alone or in combination. For example, /SPAN\_VERSIONS= (MINIMUM=V2.1,BELOW=V3.0) selects versions greater than or equal to V2.1 and less than (but not including) V3.0. Using the MAXIMUM keyword instead of BELOW would select versions that include V3.0.

### **/VERSION=version-number**

Selects software products that have the specified version.

### **/WORK=device:[directory]**

Specifies the name of the device and directory acting as a temporary work area. By default, temporary files are created in subdirectories of the user's login directory.

## Example

```
$ PRODUCT EXTRACT RELEASE_NOTES XYZ /VERSION=2.3/FILE=[RN]XYZ.TXT
```

The command in this example places the release notes for Version 2.3 of the product XYZ in a file named [RN]XYZ.TXT on your current default device.

---

## FIND

Displays the names of software product kits located in the specified directory, along with kit type and kit format information.

### Format

PRODUCT FIND product-name[...] [/qualifiers]

### Parameter

#### **product-name**

Names the product, or list of products to find.

### Qualifiers

#### **/BASE\_SYSTEM=base-system-name**

Selects software products whose base system matches the one specified. The base system name identifies both a hardware platform and an operating system. Standard names are:

| Name   | Description  |
|--------|--|
| AXPVMS | Denotes an OpenVMS Alpha product.  |
| I64VMS | Denotes an OpenVMS Integrity servers product.                                |
| VAXVMS | Denotes an OpenVMS VAX product.  |
| VMS    | Indicates a product that can be installed on more than one OpenVMS platform. |

#### **/FULL**

#### **/NOFULL (default)**

Displays information in 132-column format. The /NOFULL qualifier displays a subset of available information in 80-column format.

#### **/KIT\_ATTRIBUTES=keyword([,...])**

Selects kits by kit type or kit format, or both. Keywords are:

|                        |  |
|------------------------|--|
| FORMAT=<br>format-type | Designates the format of the product kit as follows:   |
| COMPRESSED             | Compressed format in which a data compression technique has been applied to a sequential kit. A compressed kit has a .PCSI\$COMPRESSED file type.            |
| REFERENCE              | Reference format in which product files exist in a directory tree. A .PCSI\$DESCRIPTION file in the top level of the directory tree denotes a reference kit. |
| SEQUENTIAL             | Sequential format in which product files are placed in a container file. A file type of .PCSI indicates a sequential kit.                                    |

|                      |  |
|----------------------|--|
| TYPE=<br>kit-type    | Specifies the type of product kit as follows:  |
| FULL                 | Layered product (application) software.  |
| OPERATING_<br>SYSTEM | Operating system software.   |
| MANDATORY_<br>UPDATE | A required correction to currently installed software. Functionally, this type of kit is the same as a patch kit.  |
| PARTIAL              | An upgrade to currently installed software. Installation of this kit changes the version of the product.   |
| PATCH                | A correction to currently installed software. Installation of this kit does not change the version of the product.   |
| PLATFORM             | An integrated set of software products (also called a product suite).  |
| TRANSITION           | Used to register information about a product that is installed but not recorded in the product database (for example, a product installed by VMSINSTAL). This kit does not provide product material. |

**/PRODUCER=producer-name**

Selects software products that the specified manufacturer produces.

**/SOURCE=device-name:[directory-name]**

Specifies the disk and directory where the utility searches for the software product kit or kits. If /SOURCE is not specified, the utility searches in the location defined by the logical name PCSI\$SOURCE. If PCSI\$SOURCE is not defined, and the /SOURCE qualifier is not specified, PCSI searches the current default directory.

**/SPAN\_VERSIONS=keyword([,...])**

Selects software products whose versions match the specified version criteria. The keywords are:

|                 |   |
|-----------------|---|
| ABOVE=version   | Selects versions greater than the version specified             |
| BELOW=version   | Selects versions less than the version specified                |
| MINIMUM=version | Selects versions greater than or equal to the version specified |
| MAXIMUM=version | Selects versions less than or equal to the version specified    |

The ABOVE, BELOW, MINIMUM, and MAXIMUM keywords can be used alone or in combination. For example, /SPAN\_VERSIONS= (MINIMUM=V2.1,BELOW=V3.0) selects versions greater than or equal to V2.1 and less than (but not including) V3.0. Using the MAXIMUM keyword instead of BELOW would select versions that include V3.0.

**/VERSION=version-number**

Selects software products that have the specified version.

## **Example**

```
$ PRODUCT FIND TEST* /BASE_SYSTEM=VAXVMS
```

The command in this example searches for all software product kits located in the user's default directory and displays the names of all versions of products whose names begin with "TEST" and are intended to be installed on OpenVMS VAX.

---

## INSTALL

Installs one or more software products on your system and updates the product database. You can also use this command to install patch and mandatory update kits that modify previously installed products.

### Format

PRODUCT INSTALL product-name[...] [/qualifiers]

### Description

To uninstall complete products, including any patches or mandatory updates that might have been applied to them, use the PRODUCT REMOVE command.

To uninstall patches or mandatory updates while still retaining the original product that was installed, use the PRODUCT UNDO PATCH command. However, to use PRODUCT UNDO PATCH, you must have created and retained recovery data sets for these patches. (By default, the PRODUCT INSTALL command creates a recovery data set when patch kits are installed.)

For more information about the use of recovery data sets, see the description of the PRODUCT UNDO PATCH command.

### Parameter

**product-name**

Names the product, or list of products, to install.

### Qualifiers

**/BASE\_SYSTEM=base-system-name**

Selects software products whose base system matches the one specified. The base system name identifies both a hardware platform and an operating system. Standard names are:

| Name   | Description  |
|--------|--|
| AXPVMS | Denotes an OpenVMS Alpha product.  |
| I64VMS | Denotes an OpenVMS Integrity servers product.                                |
| VAXVMS | Denotes an OpenVMS VAX product.  |
| VMS    | Indicates a product that can be installed on more than one OpenVMS platform. |

**/CONFIGURATION=(keyword[,...])**

Specifies how the configuration choices will be supplied. Keywords are:

|                |  |
|----------------|--|
| CURRENT        | Uses values from the product database. These values are the configuration choices made when the product was installed or reconfigured. |
| PRODUCER       | Uses values specified by the software manufacturer of the product.   |
| INPUT=pcf-name | Uses values from the specified product configuration file.   |



**OUTPUT=pcf-name** Writes configuration choices to the specified product configuration file. If no file name is supplied, creates a file named DEFAULT.PCSI\$CONFIGURATION in the current default directory.

The keywords CURRENT, PRODUCER, and INPUT are mutually exclusive. (CURRENT is the default if none of these keywords is specified.)

The OUTPUT keyword can be used with the CURRENT, PRODUCER, or INPUT keyword.

If you specify only one keyword, you can omit the parentheses.

**/DEBUG**

**/NODEBUG (default)**

Specifies options useful to the product kit developer during kit testing. Keywords are:

**CONFLICT\_DATA** Displays supplemental information about file and module conflict resolution. This includes the generation numbers used in the comparison, whether the object is retained or replaced, and the name of the product that supplies the object.

Use /DEBUG=CONFLICT\_DATA in conjunction with the /LOG qualifier to display all information about conflict resolution. For more information, see the *HP POLYCENTER Software Installation Utility Developer's Guide*.

**/DESTINATION=device-name:[directory-name]**

Specifies the top-level directory where the utility will install software product files. If you omit the device name, the utility uses your current default device. If you omit the directory name, the utility uses [VMS\$COMMON] as the default directory.

If you do not use this qualifier to specify a destination, the utility installs the software in the location defined by logical name PCSI\$DESTINATION. If this logical name is not defined, the utility installs the software in SYS\$SYSDEVICE:[VMS\$COMMON], the default top-level directory for software product files.

**/HELP**

**/NOHELP (default)**

Controls whether detailed explanations of product options and informational text are displayed. The first time you install a product, these explanations can help you decide which options to select. When you perform subsequent installations or upgrades, you might choose the brief explanations to save time.

When /NOHELP is selected, you can request a detailed explanation about a question by performing one of the following actions at the prompt:

- Press the Help key or PF2 key
- Type ? and press the Return key

**/KIT\_ATTRIBUTES=keyword([,...])**

Selects kits by kit type or kit format, or both. Keywords are:

## PCSI INSTALL

|                        |  |
|------------------------|--|
| FORMAT=<br>format-type | Designates the format of the product kit as follows:   |
| COMPRESSED             | Compressed format in which a data compression technique has been applied to a sequential kit. A compressed kit has a .PCSI\$COMPRESSED file type.            |
| REFERENCE              | Reference format in which product files exist in a directory tree. A .PCSI\$DESCRIPTION file in the top level of the directory tree denotes a reference kit. |
| SEQUENTIAL             | Sequential format in which product files are placed in a container file. A file type of .PCSI indicates a sequential kit.                                    |
| TYPE=<br>kit-type      | Specifies the type of product kit as follows:  |
| FULL                   | Layered product (application) software.  |
| OPERATING_<br>SYSTEM   | Operating system software.   |
| MANDATORY_<br>UPDATE   | A required correction to currently installed software. Functionally, this type of kit is the same as a patch kit.  |
| PARTIAL                | An upgrade to currently installed software. Installation of this kit changes the version of the product.   |
| PATCH                  | A correction to currently installed software. Installation of this kit does not change the version of the product.   |
| PLATFORM               | An integrated set of software products (also called a product suite).  |

### **/LOG**

#### **/NOLOG (default)**

Displays the file specification of each file processed. When logging is enabled, messages notify you whenever product files, libraries, directories, recovery data files, and product database files are created, deleted, or modified. Information about any file and module conflict resolution is also provided.

#### **/OPTIONS=(keyword[,...])**

#### **/NOOPTIONS (default)**

Specifies PRODUCT command options. The keywords are:

|           |  |
|-----------|--|
| NOCONFIRM | Omits the confirmation dialog that asks the user to verify the products that have been selected for the operation.<br>The NOCONFIRM and NODEFAULT_KIT keywords are mutually exclusive. |
|-----------|--|

**NODEFAULT\_KIT** Directs the utility to query the user instead of choosing a default kit when more than one kit that matches the selection criteria for the product is found in the source directory path. The selection criteria include the producer, base system, product name, and product version strings that are embedded in the file name of a kit.

If multiple kits are found for a selected product, and **NODEFAULT\_KIT** is not specified, the utility determines the default kit to use by applying the following rules:

1. The last character of the kit's file name (1-7) is used to order the kits by kit type. In descending order, the precedence is as follows: full, operating system, partial, patch, platform, transition, and mandatory update.
2. The file type is used to order the kits by format. In descending order, the precedence is as follows: compressed (.PCSI\$COMPRESSED), sequential (.PCSI), and reference (.PCSI\$DESCRIPTION).
3. If multiple kits are found with the same file name and file type, but differ in their directory path names, the case of their file specifications, or their file versions, then the first file found by RMS search rules takes precedence.

The **NODEFAULT\_KIT** and **NOCONFIRM** keywords are mutually exclusive.

**NOVALIDATE\_KIT** Disables validation of software product kits that are signed and have a manifest file in the source directory. The **NOVALIDATE\_KIT** and **SIGNED\_KIT** keywords are mutually exclusive.

**SHOW\_DISK\_USAGE** Displays estimated disk block usage. Both peak utilization and net change are shown in addition to the amount of free space available before and after the operation.

**SIGNED\_KIT** Requires all software product kits selected for the operation to be signed kits that have passed validation; otherwise, the operation is not performed. The **SIGNED\_KIT** and **NOVALIDATE\_KIT** keywords are mutually exclusive.

**/PRODUCER=producer-name**

Selects software products that the specified manufacturer produces.

**/RECOVERY\_MODE (default)**

**/NORECOVERY\_MODE**

Enables or disables product installation in recovery mode. The directories, files, and libraries that are modified or deleted in the installation process are saved in a directory tree on the system disk unless you specify **/NORECOVERY\_MODE**. These files, along with a copy of the product database, comprise the recovery data set.

The recovery data set is handled somewhat differently when an installation ends successfully or if it terminates unsuccessfully.

- If an installation terminates in its execution phase, either voluntarily (by using Ctrl/Y or Ctrl/C) or involuntarily (because of a fatal error), the saved recovery data is used to roll back all the displaced objects in an attempt to reinstate the product environment prior to the interrupted operation. Then the recovery data set is deleted.
- At the end of the successful installation of one or more full, platform, or partial kits, the recovery data set is deleted.
- At the end of the successful installation of one or more patch or mandatory update kits, the recovery data set is automatically retained for possible future use with the PRODUCT UNDO PATCH command unless you specify the /NOSAVE\_RECOVERY\_DATA qualifier.

**/REMARK=string**

Records a comment in the product database about the task you are performing. The PRODUCT SHOW HISTORY command displays the recorded comments. For each product, PCSI stores a chronological list of tasks you perform and the associated remarks. The default behavior is that no remark is recorded.

**/REMOTE**

**/NOREMOTE (default)**

Selects the product database located on a privately mounted system disk. By default, PCSI searches the currently booted system disk for the product database.

When you use /REMOTE, the following logical names must be defined:

- PCSI\$SYSDEVICE must specify the physical disk name of the target system disk. This disk must be mounted and allocated to the process executing the PRODUCT command.
- PCSI\$SPECIFIC must point to a system root on PCSI\$SYSDEVICE. It must be defined in the following form, where *x* is a valid system root:

PCSI\$SYSDEVICE:[SYS*x*.]

**/SAVE\_RECOVERY\_DATA (default)**

**/NOSAVE\_RECOVERY\_DATA**

Enables or disables the retention of recovery data for the PRODUCT UNDO PATCH command to use.

This qualifier applies only to patch and mandatory update kits. It is ignored when full, operating system, platform, partial, or transition kits are installed.

The directories, files, and libraries that are modified or deleted in the process of installation are saved in a directory tree on the system disk unless you specify /NOSAVE\_RECOVERY\_DATA. These files, along with a copy of the product database, comprise the recovery data set. This recovery data set can be used later to uninstall patch and mandatory update kits.

**/SOURCE=device-name:[directory-name]**

Specifies the disk and directory where the utility searches for the software product kit or kits. If /SOURCE is not specified, the utility searches in the location defined by the logical name PCSI\$SOURCE. If PCSI\$SOURCE is not defined, and the /SOURCE qualifier is not specified, PCSI searches the current default directory.

**/SPAN\_VERSIONS=keyword([,...])**

Selects software products whose versions match the specified version criteria.

The keywords are:

|                 |   |
|-----------------|---|
| ABOVE=version   | Selects versions greater than the version specified             |
| BELOW=version   | Selects versions less than the version specified                |
| MINIMUM=version | Selects versions greater than or equal to the version specified |
| MAXIMUM=version | Selects versions less than or equal to the version specified    |

The ABOVE, BELOW, MINIMUM, and MAXIMUM keywords can be used alone or in combination. For example, /SPAN\_VERSIONS= (MINIMUM=V2.1,BELOW=V3.0) selects versions greater than or equal to V2.1 and less than (but not including) V3.0. Using the MAXIMUM keyword instead of BELOW would select versions that include V3.0.

**/TEST (default)**

**/NOTEST**

Requests that PCSI run the installation verification procedure (IVP) for the product.

**/TRACE**

**/NOTRACE (default)**

Identifies the creation and deletion of subprocesses and the DCL commands and command procedures submitted to these subprocesses for execution during the processing of the PRODUCT command. Also shows the creation and deletion of scratch directories and temporary files that the PCSI utility provides for the subprocess environment. Any output that DCL produces is also displayed.

This qualifier is primarily a debugging aid for product developers to trace the execution of command procedures included in their product kits. For more information, see the *HP POLYCENTER Software Installation Utility Developer's Guide*.

**/VERSION=version-number**

Selects software products that have the specified version.

**/WORK=device:[directory]**

Specifies the name of the device and directory acting as a temporary work area. By default, temporary files are created in subdirectories of the user's login directory.

**Example**

```
$ PRODUCT INSTALL POSIX/VERSION=3.0 /CONFIGURATION=OUTPUT=POSIX.PCF
```

The command in this example installs POSIX Version 3.0 and creates a product configuration file.

---

## LIST

Lists the names of the files contained in a software product kit. All files are listed unless you use the /SELECT qualifier to specify a subset of the files.

### Format

PRODUCT LIST product-name[...] [/qualifiers]

### Parameter

#### **product-name**

Names the product, or list of products, whose kit contents are to be listed. This parameter is required.

### Qualifiers

#### **/BASE\_SYSTEM=base-system-name**

Selects software products whose base system matches the one specified. The base system name identifies both a hardware platform and an operating system. Standard names are:

| Name   | Description  |
|--------|--|
| AXPVMS | Denotes an OpenVMS Alpha product.  |
| I64VMS | Denotes an OpenVMS Integrity servers product.                                |
| VAXVMS | Denotes an OpenVMS VAX product.  |
| VMS    | Indicates a product that can be installed on more than one OpenVMS platform. |

#### **/FULL**

#### **/NOFULL (default)**

Displays information about files contained in the kit in 132-column format. The /FULL qualifier shows the name of each file, gives its size in blocks, and provides a comment field that can provide additional information—for example, the file is a product description file, a temporary file, or a module file that updates a library file. The /NOFULL qualifier displays only the name of each file in the kit in 80-column format.

#### **/KIT\_ATTRIBUTES=keyword([,...])**

Selects kits by kit type or kit format, or both. Keywords are:

|                                    |  |
|------------------------------------|--|
| <b>FORMAT=</b><br>format-type      | Designates the format of the product kit as follows:   |
| <b>COMPRESSED</b>                  | Compressed format in which a data compression technique has been applied to a sequential kit. A compressed kit has a .PCSI\$COMPRESSED file type.  |
| <b>REFERENCE</b>                   | Reference format in which product files exist in a directory tree. A .PCSI\$DESCRIPTION file in the top level of the directory tree denotes a reference kit.   |
| <b>SEQUENTIAL</b>                  | Sequential format in which product files are placed in a container file. A file type of .PCSI indicates a sequential kit.  |
| <b>TYPE=</b><br>kit-type           | Specifies the type of product kit as follows:  |
| <b>FULL</b>                        | Layered product (application) software.  |
| <b>OPERATING_</b><br><b>SYSTEM</b> | Operating system software.   |
| <b>MANDATORY_</b><br><b>UPDATE</b> | A required correction to currently installed software. Functionally, this type of kit is the same as a patch kit.  |
| <b>PARTIAL</b>                     | An upgrade to currently installed software. Installation of this kit changes the version of the product.   |
| <b>PATCH</b>                       | A correction to currently installed software. Installation of this kit does not change the version of the product.   |
| <b>PLATFORM</b>                    | An integrated set of software products (also called a product suite).  |
| <b>TRANSITION</b>                  | Used to register information about a product that is installed but not recorded in the product database (for example, a product installed by VMSINSTAL). This kit does not provide product material. |

**/OPTIONS=keyword**  
**/NOOPTIONS (default)**

Specifies PRODUCT command options. The keywords are:

|                  |  |
|------------------|--|
| <b>NOCONFIRM</b> | Omits the confirmation dialog that asks the user to verify the products that have been selected for the operation.<br>The NOCONFIRM and NODEFAULT_KIT keywords are mutually exclusive. |
|------------------|--|



**NODEFAULT\_KIT** Directs the utility to query the user instead of choosing a default kit when more than one kit that matches the selection criteria for the product is found in the source directory path. The selection criteria include the producer, base system, product name, and product version strings that are embedded in the file name of a kit.

If multiple kits are found for a selected product, and **NODEFAULT\_KIT** is not specified, the utility determines the default kit to use by applying the following rules:

1. The last character of the kit's file name (1-7) is used to order the kits by kit type. In descending order, the precedence is as follows: full, operating system, partial, patch, platform, transition, and mandatory update.
2. The file type is used to order the kits by format. In descending order, the precedence is as follows: compressed (.PCSI\$COMPRESSED), sequential (.PCSI), and reference (.PCSI\$DESCRIPTION).
3. If multiple kits are found with the same file name and file type, but differ in their directory path names, the case of their file specifications, or their file versions, then the first file found by RMS search rules takes precedence.

The **NODEFAULT\_KIT** and **NOCONFIRM** keywords are mutually exclusive.

**NOVALIDATE\_KIT** Disables validation of software product kits that are signed and have a manifest file in the source directory.

**/PRODUCER=producer-name**

Selects software products that the specified manufacturer produces.

**/SELECT=filename[,...]**

Specifies the name of a file, or a list of files; these files are in the specified product kit. You can use the asterisk (\*) and the percent sign (%) wildcard characters for all or part of the file name. The file name can contain a directory specification that includes an ellipsis (...).

**/SOURCE=device-name:[directory-name]**

Specifies the disk and directory where the utility searches for the software product kit or kits. If **/SOURCE** is not specified, the utility searches in the location that the logical name **PCSI\$SOURCE** defines. If **PCSI\$SOURCE** is not defined, and the **/SOURCE** qualifier is not specified, **PCSI** searches the current default directory.

**/SPAN\_VERSIONS=keyword([,...])**

Selects software products whose versions match the specified version criteria. The keywords are:

**ABOVE=version** Selects versions greater than the version specified



|                        |   |
|------------------------|---|
| <b>BELOW=version</b>   | Selects versions less than the version specified                |
| <b>MINIMUM=version</b> | Selects versions greater than or equal to the version specified |
| <b>MAXIMUM=version</b> | Selects versions less than or equal to the version specified    |

The ABOVE, BELOW, MINIMUM, and MAXIMUM keywords can be used alone or in combination. For example, /SPAN\_VERSIONS= (MINIMUM=V2.1,BELOW=V3.0) selects versions greater than or equal to V2.1 and less than (but not including) V3.0. Using the MAXIMUM keyword instead of BELOW would select versions that include V3.0.

**/VERSION=version-number**

Selects software products that have the specified version.

**Example**

```
$ PRODUCT LIST TEST /SELECT=TEST.* /SOURCE=[AL]
```

In this example, PCSI lists all the files that match the selection criteria TEST.\* from the kit of the product TEST that is in the [AL] directory on the user's default disk.

---

**PACKAGE**

Creates a software product kit that can be installed by using the PRODUCT INSTALL command.

**Format**

```
PRODUCT PACKAGE product-name[,...] [/qualifiers] /SOURCE=file-specification  
/DESTINATION=device-name[:directory-name]  
/MATERIAL=(path-name[,...])
```

**Description**

The PRODUCT PACKAGE command collects input from the source and material directories and creates the product kit in the destination directory. The source directory contains the required product description file (PDF) and an optional product text file (PTF) that the kit developer provides. The material directories contain the executable images and other files that make up the product. In addition, any command procedures that the product developer supplies to perform product specific installation tasks are in the material directories.

During a package operation, the PCSI utility stores the PDF and PTF in the kit in a modified format. Comments are removed from the PDF and information is added such as the size of each installed file. The PTF file is converted to text library format and given a file type of .PCSI\$TLB.

The PRODUCT PACKAGE command can create a product kit in either sequential or reference format. To create a kit in compressed format, first enter the PRODUCT PACKAGE command to create a kit in sequential format. Then enter the PRODUCT COPY command to convert this sequential kit to a kit in compressed format.

The PRODUCT PACKAGE command requires the /SOURCE, /DESTINATION, and /MATERIAL qualifiers.

**Parameter**

**product-name**

Names the product or list of products to be packaged.

**Qualifiers**

**/BASE\_SYSTEM=base-system-name**

Selects software products whose base system matches the one specified. The base system name identifies both a hardware platform and an operating system. Standard names are:

---

| <b>Name</b> | <b>Description</b>   |
|-------------|--|
| AXPVMS      | Denotes an OpenVMS Alpha product.  |
| I64VMS      | Denotes an OpenVMS Integrity servers product.                                |
| VAXVMS      | Denotes an OpenVMS VAX product.  |
| VMS         | Indicates a product that can be installed on more than one OpenVMS platform. |

---

**/COPY(default)**

**/NOCOPY**

Specifies whether you want the product material files and associated directories included in the product kit when you are producing a kit in reference format. The /NOCOPY qualifier can save file processing time when you are debugging a PDF file and do not need to produce a complete product kit.

The /NOCOPY and /FORMAT=SEQUENTIAL qualifiers are mutually exclusive.

**/DESTINATION=device-name:[directory-name]**

Specifies the location where the product kit will be created.

If /FORMAT=SEQUENTIAL is used, /DESTINATION specifies the directory where the utility creates the sequential kit. A sequential kit is a container file that includes the PDF, PTF, and all the images and other materials that make up the product. The file type of the sequential kit file is .PCSI.

If /FORMAT=REFERENCE is used (or defaulted), /DESTINATION specifies the directory where the utility creates the output PDF file and optional PTF file. The file types of the PDF and PTF files are .PCSI\$DESCRIPTION and .PCSI\$TLB, respectively. The images and other materials that make up the product are placed in a directory tree under this directory.

If the device name is not provided, the command defaults to the user's default device. If the directory name is omitted, the command defaults to the user's default directory.

The PRODUCT PACKAGE command ignores the PCSI\$DESTINATION logical name whether or not you use the /DESTINATION qualifier.

**/FORMAT=keyword**

Specifies the output format of the product kit. Keywords are:

- |            |   |
|------------|---|
| REFERENCE  | Reference format in which product files are placed in a directory tree for direct access. The utility creates a product description file, with a file type of .PCSI\$DESCRIPTION, in the top level of the directory tree. |
| SEQUENTIAL | Sequential format in which product files are placed in a container file having a .PCSI file type.   |

The default is /FORMAT=REFERENCE.

You cannot use the PRODUCT PACKAGE command to create a kit in compressed format. Instead, use the PRODUCT COPY command to convert a kit in sequential format to a kit in compressed format.

**/LOG**

**/NOLOG (default)**

Displays the file specifications of the files that are packaged in the product kit and the name of the product kit file.

**/OPTIONS=keyword**

**/NOOPTIONS (default)**

Specifies PRODUCT command options. The keyword is:

**NOCONFIRM** Omits the confirmation dialog that asks the user to verify the products that have been selected for the operation.

**/MATERIAL=(path-name[,...])**

Specifies one or more locations in which the utility can search for product material files to include in the software product kit. Material files represent the output of the producer's software engineering process, that is, all files that make up the software product, including any command procedures that might be used during installation.

Note that the location of the PDF and PTF are not specified with the /MATERIAL qualifier. See the /SOURCE qualifier for more information.

This is a required qualifier for the PRODUCT PACKAGE command. Parentheses (()) are optional only when you specify a single path name. They are required when you specify multiple path names.

The format for path-name is: device-name:[directory-name]

You can specify path-name as a:

|                    |   |
|--------------------|---|
| Specific directory | Only one directory is searched.   |
| Wildcard directory | The directory name includes one or more of the wildcard characters asterisk (*), percent sign (%), or ellipsis (...). All directories that satisfy the wildcard specification are searched.   |
| Root directory     | A period (.) following the directory name indicates a root directory specification. For example, TEST\$:[ABC.FT2.] is combined with the relative file specification from the FILE statement in the PDF to locate the file during packaging. |

When the path-name contains a root directory, the utility appends the relative file specification from the FILE statement in the PDF to the root directory to determine where to find the file. However, when either a specific directory or a wildcard directory is used in the path-name, the relative file specification from the FILE statement is not used to find the file. Instead, the directory as specified in the /MATERIAL qualifier is used to search for the file.

Note that when you use either a wildcard directory or a list of path names, if files in different directories have the same name, only the first file in the search path is packaged in the kit. As a result, the same file is packaged each time a FILE statement refers to the file name because the relative file specification is not used to identify the file uniquely. Therefore, if your product has different files with the same name in different directories, you must use the root directory form of the path-name to package these files correctly.

In general, using a specific directory or a root directory is more efficient than a wildcard directory. When packaging a product that contains hundreds of files, you might notice a significant difference in processing time, depending on the method you use to specify the path name. The choice of material path name does not affect the time required to install the kit.

**/OWNER\_UIC=uic**

Specifies the owner user identification code (UIC) for files created during a copy operation. By default, the user executing the operation owns the software product files. For example, if you are logged in to your own account, you can use this

qualifier during a copy operation to assign ownership of the product files to SYSTEM rather than to your own account. Specify the UIC in alphanumeric format (in the form [name]) or in octal group-member format (in the form [g,m]). UIC formats are described in the *OpenVMS User's Manual*.

**/PRODUCER=producer-name**

Selects software products that the specified manufacturer produces.

**/SOURCE=file-specification**

Specifies the location of the input PDF file. If the device name is omitted, it defaults to the user's default device. If the directory name is omitted, it defaults to the user's default directory. If the file name and file type components of the file specification are not provided, they default to <full-product-name>.PCSI\$DESCRIPTION.

The optional PTF file, if used, must be in the same directory and have the same file name as the PDF with a .PCSI\$TEXT file type. If a file named <full-product-name>.PCSI\$TEXT is not found, the package operation does not use a PTF file.

This is a required qualifier for the PRODUCT PACKAGE command. The logical name PCSI\$SOURCE is not used.

**/VERSION=version-number**

Selects software products that have the specified version.

**Example**

```
$ PRODUCT PACKAGE VIEWER -
_ $ /PRODUCER=ABC /BASE SYSTEM=AXPVMS -
_ $ /FORMAT=SEQUENTIAL /LOG -
_ $ /SOURCE=BUILD$: [TEST.PDF] -
_ $ /DESTINATION=DKA200: [PCSI_KITS] -
_ $ /MATERIAL=BUILD$: [TEST.VIEWER0201]
```

The directory [TEST.PDF] contains the PDF and PTF named ABC-AXPVMS-VIEWER-0201-1.PCSI\$DESC and ABC-AXPVMS-VIEWER-0201-1.PCSI\$TEXT, respectively. These files and the product material files from the BUILD\$: [TEST.VIEWER0201] directory are used to create the kit for product VIEWER. When the PRODUCT PACKAGE command completes, a sequential kit named ABC-AXPVMS-VIEWER-0201-1.PCSI is created and placed in the DKA200: [PCSI\_KITS] directory.

The material path-name can be specified using a wildcard format such as the following:

```
/MATERIAL=BUILD$: [TEST.VIEWER0201...]
```

In this case, the entire directory tree is searched to find the product files to package.

The material path-name can also be specified in root directory format such as the following:

```
/MATERIAL=BUILD$: [TEST.VIEWER0201.]
```

## **PCSI PACKAGE**

In this case, each **FILE** statement in the PDF refers to a specific subdirectory. For example, if the **FILE** statement contains the relative file specification **[DOC]CHAPTER1.HTML**, the package operation looks up the file in **BUILD\$:[TEST.VIEWER0201.DOC]CHAPTER1.HTML**. Using a root directory in the path-name allows more than one file named **CHAPTER1.HTML** to be in different subdirectories.

## RECONFIGURE

Modifies the configuration of an installed product by allowing a user to change installation options.

### Format

PRODUCT RECONFIGURE product-name[,...] [/qualifiers]

### Description

Reconfiguration of a product might result in the addition or deletion of files, or both, depending on the user's selection or deselection of options; that is, users can select options that were not selected when the product was installed, or they can deselect options that were selected when the product was installed. At the conclusion of the operation, the product database is updated to reflect the changes.

Access to the original software product kit that was used to install the product is required to perform the reconfigure operation.

### Parameter

#### **product-name**

Names the product, or list of products, to reconfigure.

### Qualifiers

#### **/BASE\_SYSTEM=base-system-name**

Selects software products whose base system matches the one specified. The base system name identifies both a hardware platform and an operating system. Standard names are:

| Name   | Description  |
|--------|--|
| AXPVMS | Denotes an OpenVMS Alpha product.  |
| I64VMS | Denotes an OpenVMS Integrity servers product.                                |
| VAXVMS | Denotes an OpenVMS VAX product.  |
| VMS    | Indicates a product that can be installed on more than one OpenVMS platform. |

#### **/CONFIGURATION=(keyword[,...])**

Specifies how the configuration choices are used. Keywords are:

|                |  |
|----------------|--|
| CURRENT        | Uses values from the product database. These values are the configuration choices made when the product was installed or reconfigured. |
| PRODUCER       | Uses values specified by the software manufacturer of the product.   |
| INPUT=pcf-name | Uses values from the specified product configuration file.   |

## PCSI RECONFIGURE

**OUTPUT=pcf-name** Writes configuration choices to the specified product configuration file. If no file name is supplied, creates a file named DEFAULT.PCSI\$CONFIGURATION in the current default directory.

The keywords **CURRENT**, **PRODUCER**, and **INPUT** are mutually exclusive. (**CURRENT** is the default if none of these keywords is specified.)

The **OUTPUT** keyword can be used with the **CURRENT**, **PRODUCER**, or **INPUT** keyword.

If you specify only one keyword, you can omit the parentheses.

### **/DEBUG**

#### **/NODEBUG (default)**

Specifies options useful to the product kit developer during kit testing. Keywords are:

**CONFLICT\_DATA** Displays supplemental information about file and module conflict resolution. This includes the generation numbers used in the comparison, whether the object is retained or replaced, and the name of the product that supplies the object.

Use **/DEBUG=CONFLICT\_DATA** in conjunction with the **/LOG** qualifier to display all information about conflict resolution. For more information, see the *HP POLYCENTER Software Installation Utility Developer's Guide*.

### **/HELP**

#### **/NOHELP (default)**

Controls whether detailed explanations of product options and informational text are displayed. The first time you install a product, these explanations can help you decide which options to select. When you perform subsequent installations or upgrades, you might choose the brief explanations to save time.

When **/NOHELP** is selected, you can request a detailed explanation about a question by performing one of the following actions at the prompt:

- Press the Help key or PF2 key
- Type ? and press the Return key

#### **/KIT\_ATTRIBUTES=keyword([,...])**

Selects kits by kit type or kit format, or both. Keywords are:



|                                    |  |
|------------------------------------|--|
| <b>FORMAT=</b><br>format-type      | Designates the format of the product kit as follows:   |
| <b>COMPRESSED</b>                  | Compressed format in which a data compression technique has been applied to a sequential kit. A compressed kit has a .PCSI\$COMPRESSED file type.            |
| <b>REFERENCE</b>                   | Reference format in which product files exist in a directory tree. A .PCSI\$DESCRIPTION file in the top level of the directory tree denotes a reference kit. |
| <b>SEQUENTIAL</b>                  | Sequential format in which product files are placed in a container file. A file type of .PCSI indicates a sequential kit.                                    |
| <b>TYPE=</b><br>kit-type           | Specifies the type of product kit as follows:  |
| <b>FULL</b>                        | Layered product (application) software.  |
| <b>OPERATING_</b><br><b>SYSTEM</b> | Operating system software.   |
| <b>PARTIAL</b>                     | An upgrade to currently installed software. Installation of this kit changes the version of the product.   |
| <b>PLATFORM</b>                    | An integrated set of software products (also called a product suite).  |

**/LOG**

**/NOLOG (default)**

Displays the file specification of each file processed. When logging is enabled, messages notify you whenever product files, libraries, directories, recovery data files, and product database files are created, deleted, or modified. Information about any file and module conflict resolution is also provided.

**/OPTIONS=(keyword[,...])**

**/NOOPTIONS (default)**

Specifies PRODUCT command options. The keywords are:

|                  |  |
|------------------|--|
| <b>NOCONFIRM</b> | Omits the confirmation dialog that asks the user to verify the products that have been selected for the operation.<br>The NOCONFIRM and NODEFAULT_KIT keywords are mutually exclusive. |
|------------------|--|

## PCSI RECONFIGURE

|                              |  |
|------------------------------|--|
| <code>NODEFAULT_KIT</code>   | <p>Directs the utility to query the user instead of choosing a default kit when more than one kit that matches the selection criteria for the product is found in the source directory path. The selection criteria include the producer, base system, product name, and product version strings that are embedded in the file name of a kit.</p> <p>If multiple kits are found for a selected product, and <code>NODEFAULT_KIT</code> is not specified, the utility determines the default kit to use by applying the following rules:</p> <ol style="list-style-type: none"><li>1. The last character of the kit's file name (1-7) is used to order the kits by kit type. In descending order, the precedence is as follows: full, operating system, partial, patch, platform, transition, and mandatory update.</li><li>2. The file type is used to order the kits by format. In descending order, the precedence is as follows: compressed (<code>.PCSI\$COMPRESSED</code>), sequential (<code>.PCSI</code>), and reference (<code>.PCSI\$DESCRIPTION</code>).</li><li>3. If multiple kits are found with the same file name and file type, but differ in their directory path names, the case of their file specifications, or their file versions, then the first file found by RMS search rules takes precedence.</li></ol> <p>The <code>NODEFAULT_KIT</code> and <code>NOCONFIRM</code> keywords are mutually exclusive.</p> |
| <code>NOVALIDATE_KIT</code>  | <p>Disables validation of software product kits that are signed and have a manifest file in the source directory. The <code>NOVALIDATE_KIT</code> and <code>SIGNED_KIT</code> keywords are mutually exclusive.</p>   |
| <code>SHOW_DISK_USAGE</code> | <p>Displays estimated disk block usage. Both peak utilization and net change are shown in addition to the amount of free space available before and after the operation.</p>   |
| <code>SIGNED_KIT</code>      | <p>Requires all software product kits selected for the operation to be signed kits that have passed validation; otherwise, the operation is not performed.</p> <p>The <code>SIGNED_KIT</code> and <code>NOVALIDATE_KIT</code> keywords are mutually exclusive.</p>   |

### **`/PRODUCER=producer-name`**

Selects software products that the specified manufacturer produces.

### **`/RECOVERY_MODE (default)`**

#### **`/NORECOVERY_MODE`**

Enables or disables product reconfiguration in recovery mode. The directories, files, and libraries that are modified or deleted in the reconfiguration process are saved in a directory tree on the system disk unless you specify `/NORECOVERY_MODE`. These files, along with a copy of the product database, comprise the recovery data set.

The recovery data set is handled somewhat differently when a reconfiguration ends successfully or if it terminates unsuccessfully.

- If a reconfiguration terminates in its execution phase, either voluntarily (by using Ctrl/Y or Ctrl/C) or involuntarily (because of a fatal error), the saved recovery data is used to roll back all the displaced objects in an attempt to reinstate the product environment prior to the interrupted operation. Then the recovery data set is deleted.
- At the end of a successful reconfiguration, the recovery data set is deleted.

**/REMARK=string**

Records a comment in the product database about the task you are performing. The PRODUCT SHOW HISTORY command displays the recorded comments. For each product, PCSI stores a chronological list of tasks you perform and the associated remarks. The default behavior is that no remark is recorded.

**/REMOTE**

**/NOREMOTE (default)**

Selects the product database located on a privately mounted system disk. By default, PCSI searches the currently booted system disk for the product database.

When you use /REMOTE, the following logical names must be defined:

- PCSI\$SYSDEVICE must specify the physical disk name of the target system disk. This disk must be mounted and allocated to the process executing the PRODUCT command.
- PCSI\$SPECIFIC must point to a system root on PCSI\$SYSDEVICE. It must be defined in the following form, where *x* is a valid system root:

PCSI\$SYSDEVICE:[SYS*x*.]

**/SOURCE=device-name:[directory-name]**

Specifies the disk and directory where the utility searches for the software product kit or kits. If /SOURCE is not specified, the utility searches in the location defined by the logical name PCSI\$SOURCE. If PCSI\$SOURCE is not defined, and the /SOURCE qualifier is not specified, PCSI searches the current default directory.

**/SPAN\_VERSIONS=keyword([,...])**

Selects software products whose versions match the specified version criteria. The keywords are:

|                 |   |
|-----------------|---|
| ABOVE=version   | Selects versions greater than the version specified             |
| BELOW=version   | Selects versions less than the version specified                |
| MINIMUM=version | Selects versions greater than or equal to the version specified |
| MAXIMUM=version | Selects versions less than or equal to the version specified    |

The ABOVE, BELOW, MINIMUM, and MAXIMUM keywords can be used alone or in combination. For example, /SPAN\_VERSIONS= (MINIMUM=V2.1,BELOW=V3.0) selects versions greater than or equal to V2.1 and less than (but not including) V3.0. Using the MAXIMUM keyword instead of BELOW would select versions that include V3.0.

## PCSI RECONFIGURE

### **/TRACE**

#### **/NOTRACE (default)**

Identifies the creation and deletion of subprocesses and the DCL commands and command procedures submitted to these subprocesses for execution during the processing of the PRODUCT command. Also shows the creation and deletion of scratch directories and temporary files that the PCSI utility provides for the subprocess environment. Any output that DCL produces is also displayed.

This qualifier is primarily a debugging aid for product developers to trace the execution of command procedures included in their product kits. See the *HP POLYCENTER Software Installation Utility Developer's Guide* for more information.

#### **/VERSION=version-number**

Selects software products that have the specified version.

#### **/WORK=device:[directory]**

Specifies the name of the device and directory acting as a temporary work area. By default, temporary files are created in subdirectories of the user's login directory.

## Example

```
$ DEFINE PCSI$SOURCE DKA500:[DWMOTIF.KIT]
$ PRODUCT RECONFIGURE DWMOTIF /VERSION=V1.2-3
```

The command in this example enters into a dialog with the user to change the configuration options for the product DECwindows Motif Version 1.2-3.

## REGISTER PRODUCT

Records information in the product database about one or more installed products that are not yet registered in the database.

### Format

```
PRODUCT REGISTER PRODUCT product-name[...] [/qualifiers]
```

### Description

The `PRODUCT REGISTER PRODUCT` command only updates the product database; it does not copy any files to your system.

You can use this command to add information to the product database about products that have been installed by a mechanism other than PCSI, such as `VMSINSTAL`. You can also use this command to store information about products previously installed by the PCSI utility if the product database needs to be rebuilt due to file corruption or deleted database files.

To register a product, you need to have a file in the source directory to supply details about the product being registered. This file can be one of the following:

- A complete product kit
- The product description file (PDF) extracted from the product kit or database
- A special transition kit that identifies files installed by a mechanism other than the PCSI utility.

If you do not have a kit available to provide detailed information about a product, you can use the command procedure `SYS$UPDATE:PCSI$REGISTER_PRODUCT.COM` to register the name of the product and its version, producer, and base system in the product database. After you register a product using the command procedure, other products can reference it, and the `PRODUCT SHOW PRODUCT` command displays it as an installed product.

### Parameter

**product-name**

Names the product, or list of products, to register.

### Qualifiers

**/BASE\_SYSTEM=base-system-name**

Selects software products whose base system matches the one specified. The base system name identifies both a hardware platform and an operating system. Standard names are:

| Name   | Description                                   |
|--------|---|
| AXPVMS | Denotes an OpenVMS Alpha product.             |
| I64VMS | Denotes an OpenVMS Integrity servers product. |
| VAXVMS | Denotes an OpenVMS VAX product.               |

## PCSI REGISTER PRODUCT

| Name | Description  |
|------|--|
| VMS  | Indicates a product that can be installed on more than one OpenVMS platform. |

### **/CHECK\_ONLY**

Concludes the action of the command after performing file conflict detection, searching the destination device for all files listed in the product description file, and displaying file lookup summary data. This option allows you to perform a “dry run” of the registration operation without modifying the product database.

### **/DESTINATION=device-name:[directory-name]**

Specifies the top-level directory where the product to be registered resides. If you omit the device name, the utility uses your current default device. If you omit the directory name, the utility uses [VMS\$COMMON] as the default directory.

If you do not use this qualifier to specify a destination, the utility uses the location defined by logical name PCSI\$DESTINATION. If this logical name is not defined, the utility registers the software in SYS\$SYSDEVICE:[VMS\$COMMON], the default top-level directory for software product files.

### **/KIT\_ATTRIBUTES=keyword([,...])**

Selects kits by kit type or kit format, or both. Keywords are:

|                               |  |
|-------------------------------|--|
| <b>FORMAT=</b><br>format-type | Designates the format of the product kit as follows:   |
|                               | <p><b>COMPRESSED</b>    Compressed format in which a data compression technique has been applied to a sequential kit. A compressed kit has a .PCSI\$COMPRESSED file type.</p> <p><b>REFERENCE</b>     Reference format in which product files exist in a directory tree. A .PCSI\$DESCRIPTION file in the top level of the directory tree denotes a reference kit.</p> <p><b>SEQUENTIAL</b>    Sequential format in which product files are placed in a container file. A file type of .PCSI indicates a sequential kit.</p>   |
| <b>TYPE=</b><br>kit-type      | Specifies the type of product kit as follows:  |
|                               | <p><b>FULL</b>            Layered product (application) software.</p> <p><b>OPERATING_</b><br/><b>SYSTEM</b>        Operating system software.</p> <p><b>PARTIAL</b>        An upgrade to currently installed software. Installation of this kit changes the version of the product.</p> <p><b>PLATFORM</b>     An integrated set of software products (also called a product suite).</p> <p><b>TRANSITION</b>    Used to register information about a product that is installed but not recorded in the product database (for example, a product installed by VMSINSTAL). This kit does not provide product material.</p> |

**/LOG**

**/NOLOG (default)**

Displays the file specifications of the product files and directories that are registered in the product database.

**/OPTIONS=keyword**

**/NOOPTIONS (default)**

Specifies PRODUCT command options. The keywords are:

**NOCONFIRM**

Omits the confirmation dialog that asks the user to verify the products that have been selected for the operation.

The NOCONFIRM and NODEFAULT\_KIT keywords are mutually exclusive.

**NODEFAULT\_KIT**

Directs the utility to query the user instead of choosing a default kit when more than one kit that matches the selection criteria for the product is found in the source directory path. The selection criteria include the producer, base system, product name, and product version strings that are embedded in the file name of a kit.

If multiple kits are found for a selected product, and NODEFAULT\_KIT is not specified, the utility determines the default kit to use by applying the following rules:

1. The last character of the kit's file name (1-7) is used to order the kits by kit type. In descending order, the precedence is as follows: full, operating system, partial, patch, platform, transition, and mandatory update.
2. The file type is used to order the kits by format. In descending order, the precedence is as follows: compressed (.PCSI\$COMPRESSED), sequential (.PCSI), and reference (.PCSI\$DESCRIPTION).
3. If multiple kits are found with the same file name and file type, but differ in their directory path names, the case of their file specifications, or their file versions, then the first file found by RMS search rules takes precedence.

The NODEFAULT\_KIT and NOCONFIRM keywords are mutually exclusive.

**NOVALIDATE\_KIT**

Disables validation of software product kits that are signed and have a manifest file in the source directory.

The NOVALIDATE\_KIT and SIGNED\_KIT keywords are mutually exclusive.

**REGISTER\_ALL\_FILES**

Registers all files listed in the product description file of the kit, even if they are not currently present on the destination device.



# PCSI REGISTER PRODUCT

**SIGNED\_KIT** Requires all software product kits selected for the operation to be signed kits that have passed validation; otherwise, the operation is not performed. The **SIGNED\_KIT** and **NOVALIDATE\_KIT** keywords are mutually exclusive.

## **/PRODUCER=producer-name**

Selects software products that the specified manufacturer produces.

## **/REMARK=string**

Records a comment in the product database about the task you are performing. The **PRODUCT SHOW HISTORY** command displays the recorded comments. For each product, PCSI stores a chronological list of tasks you perform and the associated remarks. The default behavior is that no remark is recorded.

## **/REMOTE**

### **/NOREMOTE (default)**

Selects the product database located on a privately mounted system disk. By default, PCSI searches the currently booted system disk for the product database.

When you use **/REMOTE**, the following logical names must be defined:

- **PCSI\$SYSDEVICE** must specify the physical disk name of the target system disk. This disk must be mounted and allocated to the process executing the **PRODUCT** command.
- **PCSI\$SPECIFIC** must point to a system root on **PCSI\$SYSDEVICE**. It must be defined in the following form, where *x* is a valid system root:

```
PCSI$SYSDEVICE:[SYSx.]
```

## **/SOURCE=device-name:[directory-name]**

Specifies the disk and directory where the utility searches for the software product kit or kits. If **/SOURCE** is not specified, the utility searches in the location defined by the logical name **PCSI\$SOURCE**. If **PCSI\$SOURCE** is not defined, and the **/SOURCE** qualifier is not specified, PCSI searches the current default directory.

## **/SPAN\_VERSIONS=keyword([,...])**

Selects software products whose versions match the specified version criteria. The keywords are:

|                        |   |
|------------------------|---|
| <b>ABOVE=version</b>   | Selects versions greater than the version specified             |
| <b>BELOW=version</b>   | Selects versions less than the version specified                |
| <b>MINIMUM=version</b> | Selects versions greater than or equal to the version specified |
| <b>MAXIMUM=version</b> | Selects versions less than or equal to the version specified    |

The **ABOVE**, **BELOW**, **MINIMUM**, and **MAXIMUM** keywords can be used alone or in combination. For example, **/SPAN\_VERSIONS= (MINIMUM=V2.1, BELOW=V3.0)** selects versions greater than or equal to V2.1 and less than (but not including) V3.0. Using the **MAXIMUM** keyword instead of **BELOW** would select versions that include V3.0.

## **/VERSION=version-number**

Selects software products that have the specified version.



### **Example**

```
$ PRODUCT REGISTER PRODUCT TOOLCHEST /SOURCE=DKB500:[TOOLCHEST.KIT]
```

The command in this example registers the product TOOLCHEST in the product database. TOOLCHEST was installed by VMSINSTAL, and a special transition kit is in the source directory to supply details about the product.

## PCSI REGISTER VOLUME

---

### REGISTER VOLUME

For a volume containing installed products, records a change in volume label in the product database.

For device independence, the product database identifies the destination device of an installed product by its logical volume name, not by its physical device name. The logical volume name (usually in the form DISK\$labelname) is defined by the MOUNT command and associated with the device.

### Format

```
PRODUCT REGISTER VOLUME old-volume-label device-name [/qualifiers]
```

### Description

You can check the logical volume name of a mounted device by issuing a command in the following format:

```
$ WRITE SYS$OUTPUT F$GETDVI("device", "LOGVOLNAM")
```

When you use the SET VOLUME command to change the volume label of a nonsystem device that contains installed products, you must also use the PRODUCT REGISTER VOLUME command to update the product database with this information. Register the new volume label after you dismount and remount the volume so that the new logical volume name (DISK\$labelname) is defined.

If you change the volume label of the system device, you do not need to use the PRODUCT REGISTER VOLUME command because PCSI automatically detects the change after the volume is remounted following a system reboot.

### Parameters

#### **old-volume-label**

Names the old (existing) volume label.

#### **device-name**

Names the device for which the volume label is to be changed in the product database.

### Qualifiers

#### **/LOG**

#### **/NOLOG (default)**

Displays the file specifications of the product database files that are created or modified.

#### **/REMOTE**

#### **/NOREMOTE (default)**

Selects the product database located on a privately mounted system disk. By default, PCSI searches the currently booted system disk for the product database.

When you use /REMOTE, the following logical names must be defined:

- PCSI\$SYSDEVICE must specify the physical disk name of the target system disk. This disk must be mounted and allocated to the process executing the PRODUCT command.

- PCSI\$SPECIFIC must point to a system root on PCSI\$SYSDEVICE. It must be defined in the following form, where *x* is a valid system root:

```
PCSI$SYSDEVICE:[SYSx.]
```

### **Example**

```
$ PRODUCT REGISTER VOLUME AXPVMSV62 DKA0:
```

The command in this example replaces all occurrences of the old volume label in the PCSI database with the current volume label of the specified disk.

---

## **REMOVE**

Uninstalls one or more software products from your system and updates the product database. This command operates on complete products. Any patches or mandatory updates that might have been applied to complete products are also removed.

To uninstall patches or mandatory updates while still retaining the original product that was installed, use the **PRODUCT UNDO PATCH** command.

### **Format**

**PRODUCT REMOVE** product-name[,...] [/qualifiers]

### **Parameter**

#### **product-name**

Names the installed product or list of installed products to remove. Specify only the names of complete products, not the names of patches or mandatory updates applied to products.

### **Qualifiers**

#### **/BASE\_SYSTEM=base-system-name**

Selects software products whose base system matches the one specified. The base system name identifies both a hardware platform and an operating system. Standard names are:

| <b>Name</b> | <b>Description</b>   |
|-------------|--|
| AXPVMS      | Denotes an OpenVMS Alpha product.  |
| I64VMS      | Denotes an OpenVMS Integrity servers product.                                |
| VAXVMS      | Denotes an OpenVMS VAX product.  |
| VMS         | Indicates a product that can be installed on more than one OpenVMS platform. |

#### **/LOG**

#### **/NOLOG (default)**

Displays the file specification of each file processed. When logging is enabled, messages notify you whenever product files, libraries, directories, and product database files are created, deleted, or modified.

#### **/OPTIONS=(keyword[,...])**

#### **/NOOPTIONS (default)**

Specifies **PRODUCT** command options. Keywords are:

**NOCONFIRM** Omits the confirmation dialog that asks the user to verify the products that have been selected for the operation.

**SHOW\_DISK\_USAGE** Displays estimated disk block usage. Both peak utilization and net change are shown in addition to the amount of free space available before and after the operation.

**/PRODUCER=producer-name**

Selects software products that the specified manufacturer produces.

**/REMARK=string**

Records a comment in the product database about the task you are performing. The **PRODUCT SHOW HISTORY** command displays the recorded comments. For each product, PCSI stores a chronological list of tasks you perform and the associated remarks. The default behavior is that no remark is recorded.

**/REMOTE**

**/NOREMOTE (default)**

Selects the product database located on a privately mounted system disk. By default, PCSI searches the currently booted system disk for the product database.

When you use **/REMOTE**, the following logical names must be defined:

- **PCSI\$SYSDEVICE** must specify the physical disk name of the target system disk. This disk must be mounted and allocated to the process executing the **PRODUCT** command.
- **PCSI\$SPECIFIC** must point to a system root on **PCSI\$SYSDEVICE**. It must be defined in the following form, where *x* is a valid system root:

```
PCSI$SYSDEVICE:[SYSx.]
```

**/TRACE**

**/NOTRACE (default)**

Identifies the creation and deletion of subprocesses and the DCL commands and command procedures submitted to these subprocesses for execution during the processing of the **PRODUCT** command. Also shows the creation and deletion of scratch directories and temporary files that the PCSI utility provides for the subprocess environment. Any output that DCL produces is also displayed.

This qualifier is primarily a debugging aid for product developers to trace the execution of command procedures included in their product kits. See the *HP POLYCENTER Software Installation Utility Developer's Guide* for more information.

**/VERSION=version-number**

Selects software products that have the specified version.

**/WORK=device:[directory]**

Specifies the name of the device and directory acting as a temporary work area. By default, temporary files are created in subdirectories of the the user's login directory.

## Example

```
$ PRODUCT REMOVE FTAM
```

The command in this example uninstalls the product named **FTAM** and updates the product database to remove all information about the product.

# PCSI

## SHOW HISTORY

---

### SHOW HISTORY

Displays a chronological log of operations performed on the specified products.

#### Format

PRODUCT SHOW HISTORY product-name[...] [/qualifiers]

#### Description

For each operation performed, the following information is displayed:

- Name of the product
- Type of product kit: full LP, operating system, mandatory update, partial, patch, platform, or transition
- Kit validation status
- Date of the operation

If you specify /FULL, the following additional information is also included:

- Complete date and time of the operation
- Number of times the user chose to continue from an error
- Account name from which the operation was performed
- Any text found in the remark field

The kit validation status field (VAL) codes are the following:

---

| Code | Meaning  |
|------|--|
| Val  | Kit was successfully validated.  |
| Sys  | Kit was not validated, but it was installed from OS media as part of an OpenVMS installation or upgrade.           |
| (U)  | Kit was not validated because it was an unsigned kit and therefore it did not have a manifest file created for it. |
| (M)  | Kit was not validated because its manifest file was not found in the source directory.                             |
| (D)  | Kit was not validated because the validation feature was explicitly disabled by the user.                          |
| (C)  | Kit was not validated because CDSA was not operational.  |
| -    | Not applicable for the operation (such as product removal).  |
|      | <none>   |

---

#### Parameter

##### **product-name**

Names the product or list of products to include in the display. This is an optional parameter. If you omit it, operations performed on all products will be shown.

## Qualifiers

### **/BASE\_SYSTEM=(base-system-name[,...])**

Selects software products whose base system matches the one specified. The base system name identifies both a hardware platform and an operating system. Standard names are:

| Name   | Description  |
|--------|--|
| AXPVMS | Denotes an OpenVMS Alpha product.  |
| I64VMS | Denotes an OpenVMS Integrity servers product.                                |
| VAXVMS | Denotes an OpenVMS VAX product.  |
| VMS    | Indicates a product that can be installed on more than one OpenVMS platform. |

Parentheses (()) are optional only when you specify a single base system name. They are required when you specify multiple base system names.

### **/BEFORE=time**

Selects entries that were created before the specified date and time. You can specify time as an absolute time, as a combination of absolute and delta times, or as one of the following keywords:

TODAY (default)  
TOMORROW  
YESTERDAY

For information about specifying time values, see the *OpenVMS User's Manual*.

### **/FULL**

#### **/NOFULL (default)**

Displays information in 132-column format. The **/NOFULL** qualifier displays a subset of available information in 80-column format.

### **/OPERATION=(keyword[,...])**

Specifies one or more of the following operations as the value for keyword:

INSTALL  
RECONFIGURE  
REGISTER\_PRODUCT  
REGISTER\_VOLUME  
REMOVE

Parentheses (()) are optional only when you specify a single keyword. They are required when you specify multiple keywords.

### **/PRODUCER=(producer-name[,...])**

Selects software products that the specified manufacturer produces.

Parentheses (()) are optional only when you specify a single producer name. They are required when you specify multiple producer names.

### **/REMOTE**

#### **/NOREMOTE (default)**

Selects the product database located on a privately mounted system disk. By default, PCSI searches the currently booted system disk for the product database.

## PCSI SHOW HISTORY

When you use /REMOTE, the following logical names must be defined:

- PCSI\$SYSDEVICE must specify the physical disk name of the target system disk. This disk must be mounted and allocated to the process executing the PRODUCT command.
- PCSI\$SPECIFIC must point to a system root on PCSI\$SYSDEVICE. It must be defined in the following form, where *x* is a valid system root:

```
PCSI$SYSDEVICE:[SYSx.]
```

### **/SINCE=time**

Selects entries that were created on or after the specified date and time. You can specify time as an absolute time, as a combination of absolute and delta times, or as one of the following keywords:

```
TODAY (default)  
YESTERDAY
```

For information about specifying time values, the *OpenVMS User's Manual*.

### **/USER=(username[,...])**

Displays information about the products installed, configured, or removed by the specified user.

Parentheses (()) are optional only when you specify a single user name. They are required when you specify multiple user names.

### **/VERSION=(version-number[,...])**

Selects software products that have the specified version.

Parentheses (()) are optional only when you specify one version number. They are required when you specify more than one version number.

## Example

```
$ PRODUCT SHOW HISTORY * /OPERATION=INSTALL /BEFORE=22-MAY-2002
```

The command in this example lists all the products that were installed before May 22, 2002.



---

## SHOW OBJECT

Displays information about objects created during a software product installation. Examples of software objects are files, directories, and modules in libraries.

### Format

```
PRODUCT SHOW OBJECT object-name [/qualifiers]
```

### Description

The standard display lists the name, type, generation number, and status of each object. The expanded display, which you request by using the /FULL qualifier, includes the destination root directory and the product that owns the object.

Each file and library module object has an associated generation number, either explicit or implied. A generation number is an integer value in which the largest value in a comparison of generation numbers denotes the object that supersedes the others.

The product developer specifies generation numbers to aid PCSI in resolving conflict on installation when two or more products or patch kits supply the same object. An explicit or implicit value of zero means no generation information has been supplied. A tie of non-zero generation numbers means the objects are identical and that an object from a product kit should replace a previously installed object. If all generation numbers in a comparison are zero, the conflict cannot be resolved.

Each object has an installation status. A status of "OK" means that the object is currently installed. A status of "Conflict" indicates that the object lost a generation comparison with an object of the same name supplied by another product or patch. This is not an error condition. "OK/Adopt" indicates that a product inherited the object from another product. This happens only when a product loses an object conflict to another product, and, subsequently, the other product is removed, causing the file or module on the system to be adopted by the surviving product.

### Parameter

#### **object-name**

Names the object or list of objects to include in the display. This is an optional parameter. If you omit it, all objects for the selected products will be shown. You can use the asterisk (\*) and the percent sign (%) wildcard characters to specify the object-name.

The name of a file object includes its directory specification relative to the destination root directory for the installed product. For example, a file placed in DISK\$ALPHA:[VMS\$COMMON.SYSEXE]TEST.EXE is identified in the product database as the file object [SYSEXE]TEST.EXE.

### Qualifiers

#### **/BASE\_SYSTEM=(base-system-name[,...])**

Selects software products whose base system matches the one specified. The base system name identifies both a hardware platform and an operating system. Standard names are:

## PCSI SHOW OBJECT

| Name   | Description  |
|--------|--|
| AXPVMS | Denotes an OpenVMS Alpha product.  |
| I64VMS | Denotes an OpenVMS Integrity servers product.                                |
| VAXVMS | Denotes an OpenVMS VAX product.  |
| VMS    | Indicates a product that can be installed on more than one OpenVMS platform. |

Parentheses (()) are optional only when you specify a single base system name. They are required when you specify multiple base system names.

### **/FULL**

#### **/NOFULL (default)**

Displays information in 132-column format. The /NOFULL qualifier displays a subset of available information in 80-column format.

#### **/PRODUCER=(producer-name[,...])**

Selects software products that the specified manufacturer produces.

Note that the PRODUCT SHOW HISTORY command allows you to specify both the /PRODUCER and /PRODUCT qualifiers, which you need to spell out because they are not unique within the first four characters.

Parentheses (()) are optional only when you specify a single producer name. They are required when you specify multiple producer names.

#### **/PRODUCT=(product-name[,...])**

Selects products with the specified product name.

Note that the PRODUCT SHOW HISTORY command allows you to specify both the /PRODUCER and /PRODUCT qualifiers, which you need to spell out because they are not unique within the first four characters.

Parentheses (()) are optional only when you specify a single product name. They are required when you specify multiple product names.

### **/REMOTE**

#### **/NOREMOTE (default)**

Selects the product database located on a privately mounted system disk. By default, PCSI searches the currently booted system disk for the product database.

When you use /REMOTE, the following logical names must be defined:

- PCSI\$SYSDEVICE must specify the physical disk name of the target system disk. This disk must be mounted and allocated to the process executing the PRODUCT command.
- PCSI\$SPECIFIC must point to a system root on PCSI\$SYSDEVICE. It must be defined in the following form, where *x* is a valid system root:

```
PCSI$SYSDEVICE:[SYSx.]
```

#### **/TYPE=(object-type[,...])**

Selects one or more class of objects to display. Keywords are:

|           |                            |
|-----------|----------------------------|
| ACCOUNT   | Selects account objects.   |
| DIRECTORY | Selects directory objects. |

|                   |  |
|-------------------|--|
| FILE              | Selects file objects.  |
| IMAGE_LIBRARY     | Selects image library objects.   |
| LOADABLE_IMAGE    | Selects loadable image objects.  |
| MODULE            | Selects module objects, including command definition, help, macro, object, and text library modules. |
| NETWORK           | Selects network objects.   |
| RIGHTS_IDENTIFIER | Selects rights identifier objects.   |

**/VERSION=(version-number[,...])**

Selects software products that have the specified version.

Parentheses (()) are optional only when you specify one version number. They are required when you specify more than one version number.

### Example

```
$ PRODUCT SHOW OBJECT * /PRODUCT=ABC /FULL
```

The command in this example lists all objects such as files, directories, library modules, and other objects that were created when the product ABC was installed.

---

## SHOW PRODUCT

Displays a list of software products installed on your system. Use the `/FULL` qualifier to display additional information such as kit type, maintenance activity, and software dependencies.

### Format

```
PRODUCT SHOW PRODUCT product-name[...] [/qualifiers]
```

### Parameter

#### **product-name**

Names the product or list of products to include in the display. This is an optional parameter. If you omit it, the names of all installed products will be shown.

### Qualifiers

#### **/BASE\_SYSTEM=(base-system-name[,...])**

Selects software products whose base system matches the one specified. The base system name identifies both a hardware platform and an operating system. Standard names are:

| Name   | Description  |
|--------|--|
| AXPVMS | Denotes an OpenVMS Alpha product.  |
| I64VMS | Denotes an OpenVMS Integrity servers product.                                |
| VAXVMS | Denotes an OpenVMS VAX product.  |
| VMS    | Indicates a product that can be installed on more than one OpenVMS platform. |

Parentheses (()) are optional only when you specify a single base system name. They are required when you specify multiple base system names.

#### **/FULL**

#### **/NOFULL (default)**

Displays information in 132-column format. The `/NOFULL` qualifier displays a subset of available information in 80-column format.

#### **/MAINTENANCE=(product-name[,...])**

Displays the products to which the named maintenance products have been applied. A maintenance product is either a patch kit or a mandatory update kit.

Parentheses (()) are optional only when you specify a single product name. They are required when you specify multiple product names.

To list all maintenance products that have been applied to a particular product, use the following command:

```
PRODUCT SHOW PRODUCT product-name /FULL
```

#### **/PRODUCER=(producer-name[,...])**

Selects software products that the specified manufacturer produces.

Parentheses (()) are optional only when you specify a single producer name. They are required when you specify multiple producer names.

**/REFERENCED\_BY=(product-name[,...])**

Displays products that are referenced by the named product. Use this qualifier to show if the product, specified in the /REFERENCED\_BY qualifier, has a software dependency on the product or products specified in the product-name parameter of the SHOW PRODUCT command. If you specify an asterisk (\*) as the product name, all referenced products are listed for the product named in the /REFERENCED\_BY qualifier.

Parentheses (()) are optional only when you specify a single product name. They are required when you specify multiple product names.

To list all products that require a specified product to be installed, use the command:

```
PRODUCT SHOW PRODUCT product-name /FULL /REFERENCED_BY=*
```

To list all products that are referenced by (that is, required by) a particular product, use the command:

```
PRODUCT SHOW PRODUCT * /REFERENCED_BY=product-name
```

To list all products that are referenced by (that is, required by) other products, use the command:

```
PRODUCT SHOW PRODUCT * /REFERENCED_BY=*
```

**/REMOTE**

**/NOREMOTE (default)**

Selects the product database located on a privately mounted system disk. By default, PCSI searches the currently booted system disk for the product database.

When you use /REMOTE, the following logical names must be defined:

- PCSI\$SYSDEVICE must specify the physical disk name of the target system disk. This disk must be mounted and allocated to the process executing the PRODUCT command.
- PCSI\$SPECIFIC must point to a system root on PCSI\$SYSDEVICE. It must be defined in the following form, where *x* is a valid system root:

```
PCSI$SYSDEVICE:[SYSx.]
```

**/SPAN\_VERSIONS=keyword([,...])**

Selects software products whose versions match the specified version criteria. The keywords are:

|                 |   |
|-----------------|---|
| ABOVE=version   | Selects versions greater than the version specified             |
| BELOW=version   | Selects versions less than the version specified                |
| MINIMUM=version | Selects versions greater than or equal to the version specified |
| MAXIMUM=version | Selects versions less than or equal to the version specified    |

The ABOVE, BELOW, MINIMUM, and MAXIMUM keywords can be used alone or in combination. For example, /SPAN\_VERSIONS= (MINIMUM=V2.1,BELOW=V3.0) selects versions greater than or equal to V2.1 and less than (but not including) V3.0. Using the MAXIMUM keyword instead of BELOW would select versions that include V3.0.

**/VERSION=(version-number[,...])**

Selects software products that have the specified version.

## **PCSI SHOW PRODUCT**

Parentheses (()) are optional only when you specify one version number. They are required when you specify more than one version number.

### **Example**

```
$ PRODUCT SHOW PRODUCT * /REFERENCED_BY=DECNET_OSI
```

The command in this example lists all products on which the DECnet-Plus product is dependent.

## SHOW RECOVERY\_DATA

Displays patch recovery data sets in chronological order, starting with the set created most recently and ending with the oldest one. Each recovery data set identifies one or more patches that can be uninstalled.

### Format

PRODUCT SHOW RECOVERY\_DATA [/qualifiers]

### Parameters

None.

### Qualifiers

#### **/BEFORE=time**

Selects recovery data sets created before the specified date and time. You can specify time as an absolute time, as a combination of absolute and delta times, or as one of the following keywords:

TODAY (default)  
TOMORROW  
YESTERDAY

For information about specifying time values, see the *OpenVMS User's Manual*.

#### **/FULL**

#### **/NOFULL (default)**

Displays information in 132-column format. The **/NOFULL** qualifier displays a subset of available information in 80-column format.

#### **/LOG**

#### **/NOLOG (default)**

Displays the file specifications of recovery data set files as they are accessed.

#### **/NEWEST=count**

Displays the most recently created patch recovery data sets. For example, if you specify **/NEWEST=2**, the **SHOW RECOVERY\_DATA** command displays the two newest recovery data sets. If you do not specify a number with this qualifier, the default value is 1.

#### **/OLDEST=count**

Displays the oldest recovery data sets. For example, if you specify **/OLDEST=2**, the **SHOW RECOVERY\_DATA** command displays the two oldest recovery data sets. If you do not specify a number with this qualifier, the default value is 1.

#### **/REMOTE**

#### **/NOREMOTE (default)**

Selects recovery data sets located on a privately mounted system disk. By default, PCSI searches the currently booted system disk for recovery data sets.

When you use **/REMOTE**, the following logical names must be defined:

- **PCSI\$SYSDEVICE** must specify the physical disk name of the target system disk. This disk must be mounted and allocated to the process executing the **PRODUCT** command.

## PCSI SHOW RECOVERY\_DATA

- PCSI\$SPECIFIC must point to a system root on PCSI\$SYSDEVICE. It must be defined in the following form, where *x* is a valid system root:

```
PCSI$SYSDEVICE:[SYSx.]
```

### **/SINCE=time**

Selects recovery data sets that were created on or after the specified date and time. You can specify time as an absolute time, as a combination of absolute and delta times, or as one of the following keywords:

```
TODAY (default)  
YESTERDAY
```

For information about specifying time values, see the *OpenVMS User's Manual*.

### **Example**

```
$ PRODUCT SHOW RECOVERY_DATA /SINCE=10-DEC-2002
```

The command in this example displays the recovery data sets created on or after December 10, 2002, starting with the one created most recently.



---

## SHOW UTILITY

Displays the version of PCSI that you are using.

### Format

PRODUCT SHOW UTILITY

### Parameters

None.

### Qualifiers

None.

### Example

```
$ PRODUCT SHOW UTILITY
POLYCENTER Software Installation utility version: V8.3-134

Product Configuration File (PCF) support level: 1
Product Description File (PDF) support level: 10
Product Text File (PTF) support level: 2
Image Name: DISK$V83SYS:[SYS0.][SYSEXE]PCSI$MAIN.EXE;1
```

The command in this example shows the version of the PCSI utility, its component support levels, and the full file specification of the PCSI image that is executing the command.

## UNDO PATCH

Uninstalls patches or mandatory updates from your system. This command uses the recovery data sets that were created by the PRODUCT INSTALL command when these patches were installed. The associated recovery data sets are deleted at the conclusion of the operation.

### Format

```
PRODUCT UNDO PATCH [/qualifiers]
```

### Description

You can “undo” patches only in reverse chronological order of the creation dates of their recovery data sets. Thus, if you install patches A, B, and C with separate PRODUCT INSTALL commands, and you want to “undo” patch B, the PRODUCT UNDO PATCH command requires that patch C be removed along with patch B. To remove complete products, including any patches or mandatory updates that have been applied to them, use the PRODUCT REMOVE command instead.

A recovery data set contains a copy of the directories, files, and libraries that were modified or deleted by the execution of a PRODUCT INSTALL command. In addition, a snapshot of the product database is included, along with other information needed to restore the software environment. Each recovery data set is stored in a directory tree on the system device in [PCSI\$UNDO\_ *nnn*...], where *nnn* is a number from 001 to 999. The most recent data set is number 001; all data sets are renumbered when a new data set is added or deleted from the stack.

The PRODUCT INSTALL command creates a recovery data set when patches (also known as remedial kits or ECOs) are installed unless you disable this feature with the /NOSAVE\_RECOVERY\_DATA qualifier. A recovery data set contains information about all patches that are installed concurrently. The PRODUCT UNDO command removes all the patches that are in the selected recovery data sets. Therefore, if multiple patches are installed in one operation, they can be removed only as a group.

You can use the PRODUCT SHOW RECOVERY\_DATA command to list all recovery data sets and find out which patches can be removed. To delete unwanted recovery data sets, use the DELETE RECOVERY\_DATA command.

### Qualifiers

#### **/ALL**

Uninstalls all patch and mandatory updates for which recovery data has been saved. Once the operation completes, all the recovery data sets are deleted and cannot be reused. If you do not specify the /ALL, /NEWEST, or /SINCE qualifier, only the most recently created recovery data set is used to select patches and mandatory updates to remove.

#### **/LOG**

#### **/NOLOG (default)**

Displays the file specifications of files as they are accessed; also provides other information related to file activity. For example, when logging is enabled, messages notify you when product files, libraries, directories, and product database files are created, deleted, or modified.

**/NEWEST=count**

Selects the most recently created patch recovery data sets. For example, if you specify `/NEWEST=3`, the `PRODUCT UNDO PATCH` command uninstalls patches using data from the three newest recovery data sets. If you do not specify a number with this qualifier, the default value is 1.

**/OPTIONS=keyword**

**/NOOPTIONS (default)**

Specifies `PRODUCT` command options. The keyword is:

|                        |   |
|------------------------|---|
| <code>NOCONFIRM</code> | Omits the confirmation dialog that asks the user to verify the recovery data sets that have been selected for processing. |
|------------------------|---|

**/REMOTE**

**/NOREMOTE (default)**

Selects recovery data sets located on a privately mounted system disk and restores the product database to this disk. By default, PCSI searches the currently booted system disk for recovery data sets.

When you use `/REMOTE`, the following logical names must be defined:

- `PCSI$SYSDEVICE` must specify the physical disk name of the target system disk. This disk must be mounted and allocated to the process executing the `PRODUCT` command.
- `PCSI$SPECIFIC` must point to a system root on `PCSI$SYSDEVICE`. It must be defined in the following form, where *x* is a valid system root:

```
PCSI$SYSDEVICE:[SYSx.]
```

**/SINCE=time**

Selects recovery data sets that were created on or after the specified date and time. You can specify time as an absolute time, as a combination of absolute and delta times, or as one of the following keywords:

```
TODAY (default)  
YESTERDAY
```

For information about specifying time values, see the *OpenVMS User's Manual*.

**/TRACE**

**/NOTRACE (default)**

Identifies the creation and deletion of subprocesses and the DCL commands and command procedures submitted to these subprocesses for execution during the processing of the `PRODUCT` command. Messages log the creation and deletion of scratch directories and temporary files that the PCSI utility provides for the subprocess environment. Any output that DCL produces is also displayed.

This qualifier is primarily a debugging aid for product developers to trace the execution of command procedures included in their product kits. See the *HP POLYCENTER Software Installation Utility Developer's Guide* for more information.

## PCSI UNDO PATCH

### Example

```
$ PRODUCT UNDO PATCH
```

The command in this example uninstalls all patch and mandatory update kits that were installed in the last `INSTALL` operation performed with the `/SAVE_RECOVERY_DATA` qualifier. The recovery data set used in this operation is deleted at the end of the operation and cannot be reused.

---

## SAS Controller

### 5.1 SAS Description

Serial Attached SCSI (SAS) is a T10 standard serial interconnect for mass storage devices. SAS provides faster speeds, longer distances, simpler cables, and more compatible connectors than parallel SCSI transport.

The SAS interconnect includes three transport-level protocols:

- Serial SCSI Protocol (SSP) for communicating with SAS devices
- Serial ATA Tunneling Protocol (STP) for communicating with SATA devices
- Serial Management Protocol (SMP) for communicating with expanders

---

**Note**

---

OpenVMS Version 8.3 supports only internal (direct-attached) SAS drives.

---

### 5.2 Integrated RAID

RAID is used where extra performance, storage capacity, or redundancy of a RAID configuration, or all three, are required. OpenVMS Version 8.3 supports only RAID 1 and its Global Hot Spare capability.

On Integrity server systems, the SAS utility (SAS\$UTIL) is an OpenVMS system management and diagnostic tool that is capable of configuring Integrated RAID (IR) functionality for the HP 8 Internal Port Serial Attached SCSI Host Bus Adapter (SAS Controller).

RAID 1 for the SAS Controller is called Integrated Mirroring. The following sections describe Integrated Mirroring and Global Hot Spare capability.

#### 5.2.1 Integrated Mirroring

Integrated Mirroring (IM) is a simple sector-to-sector physical mirror of one drive to another drive. Each SAS controller supports up to two simultaneously mirrored volumes. Both disks in an IM volume must be connected to the same SAS controller.

IM provides fault-tolerant protection for critical data such as operating systems on servers and high-performance workstations. Usually, one of the IM volumes is the boot volume. If a disk in an IM volume fails, the hot spare and hot swap capability allows the volume to be restored easily simply by swapping disks. The firmware then automatically remirrors the swapped disk.

The advantage of IM is that a mirrored copy of the data is always available, and that reads performance is enhanced. The disadvantage is that write performance is diminished.

## SAS Controller

### 5.2 Integrated RAID

Data written to an IM volume is written simultaneously to both disks. The overall write operation is not complete until both disk writes complete; therefore, this operation is somewhat slower than a single disk write. Reads from an IM volume are load balanced between the primary and secondary disks for better performance.

#### 5.2.2 Global Hot Spare Capability

Each SAS Controller can have a single Global Hot Spare disk available to both IM volumes, making them even more fault tolerant. This disk automatically replaces a failed IM disk. When the failed disk is replaced in the same physical location, the new disk automatically becomes the new hot spare.

### 5.3 SAS Utility Usage Summary

You must have SYSPRIV privilege to run the SAS utility.

To invoke the SAS utility, enter the following command at the DCL command prompt (\$):

```
$ RUN SYSSYSTEM:SAS$UTIL
```

The SAS utility returns the following prompt:

```
SAS>
```

At the SAS prompt, you can enter any SAS utility command described in the following sections.

### 5.4 Restrictions

The following restrictions apply to the use of the SAS utility:

- All physical disks that are part of either an IR volume or a hot spare must be on the same SAS Controller.
- A maximum of two IR volumes per controller can be created.
- The total number of physical disks in a volume and hot spare disks cannot exceed eight for the SAS Controller. The total number of physical disks combined for two volumes cannot exceed ten.
- A RAID 1 volume must have exactly two physical disks.
- The size of an IR volume cannot exceed 2 TB.
- Setting a unique device ID (UDID) is required for external SAS and SATA disks.

---

#### Note

---

OpenVMS Version 8.3 supports internal (direct-attached) SAS drives and RAID 1 only.

---

## **5.5 Additional Information**

For additional information, see the following:

- Service guide for your particular Integrity servers at the “Enterprise Servers, Workstations Systems Hardware” link at the following Web site:

<http://www.docs.hp.com>

- Installation guide of your particular Integrity servers at the “Network and Systems Management” link at the following Web site:

<http://www.docs.hp.com>

## **5.6 SAS Utility Commands**

The following sections describe SAS utility commands and provide examples of their use.

## SAS Controller ADD UNIT

---

### ADD UNIT

Creates a new Integrated RAID (IR) volume.

An IR volume ID is created whenever an IR volume is created.

### Format

```
ADD UNIT /DISK=sas_id (...) /RAID=1
```

### Qualifiers

#### **/CACHE**

#### **/NOCACHE (default)**

Enables or disables write caching to the physical disk. Write caching to the physical disk is set to off by default.

#### **/DISK=sas\_id(...)**

This qualifier is required. Specifies the SAS ID of the physical disk to be added to the IR volume set. (The SAS ID is the ID shown when you enter the SAS command SHOW DISK.) Enclose multiple SAS IDs in parentheses.

The effective size of the RAID volume is automatically determined and set to the maximum size available. The firmware supports disks of varying sizes; however, the excess space of a larger disk or disks is unusable. Volume expansion is not supported; once a volume is created, its size cannot be increased.

A physical disk must be dismounted in OpenVMS before it can be added to the IR volume set.

#### **/RAID=(0 | 1 | 10)**

This qualifier is required. Specifies the RAID level of the IR volume set.

RAID levels are the following:

| RAID Level | Description                   |
|------------|-------------------------------|
| RAID 0     | Integrated Striping           |
| RAID 1     | Integrated Mirroring          |
| RAID 10    | Integrated Mirroring Enhanced |

---

#### **Note**

OpenVMS Version 8.3 supports RAID 1 (Integrated Mirroring).

---

#### **/SPARE=sas\_id**

Specifies the SAS ID of the physical disk to be added as the Global Hot Spare disk.

This qualifier is required when specifying a Global Hot Spare disk for a RAID 1 configuration.



You can configure one Global Hot Spare disk per controller. The spare drive can be shared between two RAID 1 IR volume sets per controller. The size of the disk specified as /SPARE should be greater than or equal to the size of at least one of the physical disks on the IR volume.

**/SYNCH**

**/NOSYNCH (default)**

This qualifier applies only to RAID 1 IR volumes. Specifies the use of high-priority or low-priority resynchronization. High-priority resynchronization is set to OFF by default.

**/UNSAFE**

Overrides the restriction that limits OpenVMS support to RAID 1 only.

**Example**

SAS> SHOW DISK

Port \_PKA0:

| ID | Enc | PHY | SlT | Device | Type | Size(MB) | SAS Address       | Product Name    |
|----|-----|-----|-----|--------|------|----------|-------------------|-----------------|
| 01 | DA  | 04  | 01  | DKA100 | SAS  | 34732    | 5000C500-00334CCD | HP DG036..HPD43 |
| 02 | DA  | 05  | 02  | DKA200 | SAS  | 70007    | 5000C500-00208185 | HP DG072..HPD43 |
| 03 | DA  | 06  | 03  | DKA300 | SAS  | 34732    | 5000C500-0033D76D | HP DG036..HPD43 |
| 04 | DA  | 07  | 04  | DKA400 | SAS  | 34732    | 5000C500-0030B02D | HP DG036..HPD43 |

SAS> ADD UNIT /RAID=1 /DISK=(2,3) /SPARE=4

IR Volume 4 created.

.  
.  
.

SAS> SHOW DISK

Port \_PKA0:

| ID | Enc | PHY | SlT | Device | Type   | Size(MB) | SAS Address       | Product Name      |
|----|-----|-----|-----|--------|--------|----------|-------------------|-------------------|
| 01 | DA  | 04  | 01  | DKA100 | SAS    | 34732    | 5000C500-00334CCD | HP DG036..HPD43   |
| 04 | -   | -   | -   | DKA4   | RAID 1 | 34332    | 9378ACB0-072A3D4E | LSIL Logic..3000L |

In this example, a RAID 1 volume is created. It is comprised of physical disks with SAS IDs of 2 and 3, and a Global Hot Spare disk with an SAS ID of 4. The IR volume is assigned IR volume ID 4.

## SAS Controller DELETE DISK

---

### DELETE DISK

Deletes a Global Hot Spare disk that is part of an IR volume set.

#### Format

```
DELETE DISK /SPARE
```

#### Qualifiers

##### **/SPARE**

This qualifier is required. Deletes the Global Hot Spare disk in the IR volume set.

#### Example

```
SAS> DELETE DISK /SPARE  
Global Hot Spare disk deleted.
```

This example shows the deletion of the Global Hot Spare disk in the IR volume set.

## DELETE UNIT

Deletes the IR volume specified by the IR volume ID.

### Format

```
DELETE UNIT volume_id
```

### Parameters

**volume\_id**

The IR volume ID number to be deleted. (To display IR volume IDs, enter the SAS command SHOW DISK or SHOW UNIT.

The IR volume must be dismounted in OpenVMS before it can be deleted.

### Qualifiers

**/CONFIRM (default)**

**/NOCONFIRM**

Controls whether a question about confirming the DELETE UNIT command is displayed.

### Example

```
SAS> DELETE UNIT 4  
  
WARNING: Proceeding with this operation may cause data loss.  
Would you like to continue (Yes/No) [NO]? Yes  
IR Volume ID 4 deleted.
```

This example shows the deletion of IR Volume ID 4.

## SAS Controller

### EXIT

---

#### EXIT

Exits the SAS utility and returns to the DCL prompt (\$).

#### Format

EXIT

#### Example

```
SAS> EXIT
```

```
$
```

This command exits the SAS utility.

## SET CONTROLLER

Selects the default controller specified by the device name.

This command is required before entering all SAS utility commands except SHOW CONTROLLER and SHOW VERSION.

### Format

```
SET CONTROLLER device_name
```

### Parameters

**device\_name**

The device name has the format *ddcu*, where:

*dd* is the device code.  
*c* is the controller designation A through Z.  
*u* is the unit number (0 through 9999).

To display device names, enter the SAS command SHOW CONTROLLER.

### Example

```
SAS> SET CONTROLLER PKA0  
Selected Controller _PKA0: is a LSISAS10XX device.  
SAS>
```

In this example, controller *\_PKA0:* is selected as the default controller.

## SAS Controller SET DISK

---

### SET DISK

Modifies physical disk properties such as turning the Locate LED on or off and specifying the unique device ID (UDID) to external SAS and SATA devices.

### Format

```
SET DISK sas_id
```

### Parameters

#### **sas\_id**

Specifies the SAS ID of the target SAS disk to be modified. (To display SAS IDs, enter the SAS command SHOW DISK.)

### Qualifiers

#### **/IDENT=udid**

Specifies the unique device ID (UDID), which is used as the unit number in the device name for an external SAS or SATA disk. The device name is in the form \$3\$dgaxyz, where *xyz* is the UUID for external SAS and SATA disks.

The UDID can be a number between 1 and 9999.

See the /REMOVE qualifier to remove a UDID.

#### **/LED=OFF**

#### **/LED=ON**

Sets the Locate LED, which can be used to find the SAS or SATA disk.

#### **/REMOVE**

Remove the unique device ID (UUID) for an external SAS or SATA disk.

### Example

```
SAS> SET DISK 1 /LED=ON
```

In this example, the SAS ID 1 Locate LED is turned on.

---

## SET UNIT

Modifies IR volume characteristics.

### Format

SET UNIT volume\_id

### Parameters

**volume\_id**

Specifies the IR volume ID of the IR volume to be modified.

(To display all IR volume IDs in the SAS Controller, enter the SAS command SHOW DISK or SHOW UNIT command.)

### Qualifiers

**/ACTIVE**

Activates the specified IR volume.

**/CACHE**

**/NOCACHE (default)**

Specifies write caching to a physical disk. Write caching is turned off by default.

**/DISABLE**

Temporarily disables all IR volumes on the SAS Controller.

**/ENABLE**

Enables all IR volumes previously disabled by the /DISABLE qualifier.

**/INACTIVE**

Deactivates the specified IR volume.

**/LED=OFF**

**/LED=ON**

Sets the Locate LED for all physical disks on the IR volume to off or on.

**/SPARE=sas\_id**

Specifies the disk SAS ID to be added as the Global Hot Spare disk. (The SAS ID is the ID displayed when you enter the SAS command SHOW DISK.)

This qualifier is required only when specifying a Global Hot Spare disk for a RAID 1 configuration.

You can configure one Global Hot Spare disk per controller. The spare drive can be shared between two RAID 1 IR volume sets per controller. The size of the disk specified as /SPARE should be equal to or greater than the size of at least one of the physical disks on the IR volume.

**/SYNCH**

**/NOSYNCH (default)**

Specifies the use of high-priority or low-priority resynchronization. High-priority resynchronization is off by default.

## SAS Controller SET UNIT

### Example

```
SAS> SHOW DISK
Port _PKA0:
-----
  ID  Enc PHY Slt  Device  Type  Size(MB)  SAS Address  Product Name
-----
  01  DA  04  01  DKA100  SAS    34732  5000C500-00334CCD  HP DG036..HPD43
  05  DA  00  05  DKA500  SAS    34732  5000C500-003306B1  HP DG036..HPD43
  04  -   -   -   DKA4    RAID 1  34332  603A21ED-0869B091  LSIL Logic..3000L
SAS>
SAS> SHOW UNIT
IR Volume information:
-----
IR Volume 4
-----
  Volume Type      : RAID 1 (LSI Logic Integrated Mirror)
  Volume State     : Optimal
  Size             : 69495 MB / 142325760 blocks
IR Disk 1         : Source Disk
  Disk State       : Online
  Slot ID          : 1
  SAS WWID         : 5000C500-0134CB8D
IR Disk 0         : Secondary Disk
  Disk State       : Online
  Slot ID          : 7
  SAS WWID         : 5000C500-0134DBB5
SAS>
SAS> SET UNIT 4 /SPARE=6
Global Hot Spare 6 added to Volume Set 4.
SAS> SHOW UNIT
IR Volume information:
-----
IR Volume 4
-----
  Volume Type      : RAID 1 (LSI Logic Integrated Mirror)
  Volume State     : Optimal
  Size             : 69495 MB / 142325760 blocks
IR Disk 1         : Source Disk
  Disk State       : Online
  Slot ID          : 1
  SAS WWID         : 5000C500-0134CB8D
IR Disk 0         : Secondary Disk
  Disk State       : Online
  Slot ID          : 7
  SAS WWID         : 5000C500-0134DBB5
IR Hot Spare      : 7
  Hot Spare Status : Active
  Slot ID          : 6
  SAS WWID         : 12210000-06000000
```

This example shows a Global Hot Spare disk added to an IR volume set.



---

## SHOW CONTROLLER

Displays information about the SAS Controller.

### Format

SHOW CONTROLLER [device\_name]

### Parameters

**device\_name: (OPTIONAL)**

The device name is an SAS device name used to display information about a specific controller. The device name has the format *ddcu*, where:

*dd* is the device code.  
*c* is the controller designation A through Z.  
*u* is the unit number (0 through 9999).

If you do not specify a device name, all controllers are displayed.

### Qualifiers

**/DEFAULT**

Displays information about the default controller.

**/FULL**

Displays additional information about the SAS Controller.

### Example

```
SAS> SHOW CONTROLLER

A default controller is not set. All matching controllers displayed.

Adapter: PKA0:
Controller Type      : SAS LSISAS1068
Firmware version    : 1.10.0.0
SAS WWID             : 500605B0-00001A20
RAID Capabilities   RAID 0 (Integrated Striping) supported.
                   RAID 0+1 (Integrated Mirroring Enhanced) supported.
                   RAID 1 (Integrated Mirroring) supported.
Active IR Volumes   : 1 of 2
Active PHYS disk    : 3 of 10
Cache:
  Not Available.
Battery:
  Not Available.
```

This example shows SAS Controller information.

## SAS Controller SHOW DISK

---

### SHOW DISK

Displays a table of available SAS, SATA, and IR volumes in the SAS Controller. Each column in the table is displayed as follows:

| Volume       | Description  |
|--------------|--|
| ID           | SAS ID for SAS/SATA device.<br>RAID volume ID for RAID volume set.   |
| Enc          | Enclosure number: <ul style="list-style-type: none"><li>• Direct attached is displayed as "DA."</li><li>• Non-direct attached shows the enclosure handle number.</li></ul> |
| PHY          | SAS PHY number of the physical disk.   |
| SlT          | Physical slot or element index in the enclosure where the target device is physically located.   |
| Device       | OpenVMS device name.   |
| Type         | Device type.   |
| Size         | Disk size in MB.   |
| SAS Address  | SAS address (World Wide Identifier) of the device.   |
| Product Name | Product model of the disk.   |

### Format

```
SHOW DISK [sas_id]
```

### Parameters

#### **sas\_id**

The SAS ID is the ID shown when you enter the SAS command SHOW DISK.

If you do not enter a SAS ID, the SAS utility displays all available physical SAS disks.

### Qualifiers

#### **/FULL**

Displays additional information about disks.

### Example

```
SAS> SHOW DISK
Port _PKA0:
-----
  ID  Enc  PHY  SlT  Device  Type  Size(MB)  SAS Address  Product Name
-----
  01  DA   04   01   DKA100  SAS    34732     5000C500-00334CCD  HP DG036..HPD43
  08  DA   03   08   DKA800  SATA    57231     D83F3C15-C9A98294  ATA FUJIT..034EN
  04  -    -    -    DKA4    RAID 1  34332     603A21ED-0869B091  LSIL Logic..3000L
SAS>
```

This example shows all devices connected to the SAS Controller.

---

## **SHOW ENCLOSURE**

Displays information about the SAS enclosure connected to the SAS Controller.

### **Format**

```
SHOW ENCLOSURE [encl_id]
```

### **Parameters**

#### **encl\_id**

Displays information about a specific SAS enclosure.

If the enclosure ID is not specified, the SAS utility displays information about all available enclosures that the SAS Controller finds.

### **Qualifiers**

#### **/FULL**

Displays additional information about SAS enclosures.

### **Example**

```
SAS> SHOW ENCLOSURE

Enclosure 1
  Encl WWID      : 500605B0-00001A20
  Num slots     : 8
  Start slot    : 1
  Encl Flags    : SEP BUS/Target ID is not valid.
                : Start BUS/Target ID is not valid.
                : IOC (direct attached) SGPIO.
```

This example shows information about internal Enclosure 1 connected to the SAS Controller.

## SAS Controller SHOW EXPANDER

---

### SHOW EXPANDER

Displays information about the SAS expander connected to the SAS Controller.

#### Format

```
SHOW EXPANDER [exp_id]
```

#### Parameters

##### **exp\_id**

Displays information about a specific SAS expander.

If an expander ID is not specified, the SAS utility displays all available SAS expanders that the SAS Controller finds.

#### Qualifiers

##### **/FULL**

Displays additional information about the expanders in the SAS domain.

#### Example

```
SAS> SHOW EXPANDER
Expander 1
  Physical Port   : 0
  SAS WWID       : 500508B3-00A1396F
  Dev Handle     : 9
  Num PHYs      : 13
  SAS Level     : 1
  Exp Flags     : Device has configurable route table.
  Prog Link Rate : Max 3.0Gbps  Min 1.5Gbps
  HW Link Rate  : Max 3.0Gbps  Min 1.5Gbps
  PHY Info      : Table Routing 3.0Gbps speed
  Att Dev Info  : SMP Target  LSI Device
```

This example shows information about external SAS Expander 1, which is connected to the SAS Controller.

---

## SHOW PHY

Displays SAS PHY information for all connections in the SAS Controller.

### Format

```
SHOW PHY [phy_id]
```

### Parameters

#### **phy\_id**

Display information about a specific SAS PHY ID. (Use the SAS command SHOW DISK to display SAS PHY IDs.)

If a PHY ID is not specified, the utility displays all available PHYs on the SAS Controller.

### Qualifiers

#### **/ERROR**

Displays SAS PHY error counters.

#### **/FULL**

Displays additional information about the PHYs.

### Example

```
SAS> SHOW PHY 0
PHY 0
  OwnerDev           : 1
  SAS WWID           : 5000C500-003306B1
  DevHandle          : 9
  PhyIdentifier      : 0
  Device Info       : SSP Target  Direct Attached
  Flag              : SGPIO DA Enclosure present.
  PHY Info          : 3.0Gbps speed
SAS>
```

This example shows the SAS PHY connection for PHY 0.

## SAS Controller SHOW UNIT

---

### SHOW UNIT

Displays the IR volumes configured in the SAS Controller.

### Format

SHOW UNIT [volume\_id]

### Parameters

#### **volume\_id**

Displays information about a specific IR volume.

If a volume ID is not specified, the SAS utility displays all available IR volumes that the SAS Controller finds.

### Qualifiers

#### **/FULL**

Displays additional information about IR volumes.

### Example

```
SAS> SHOW UNIT
IR Volume information:
-----
IR Volume 4
-----
Volume Type       : RAID 1 (LSI Logic Integrated Mirror)
Volume State      : Optimal
Size              : 69495 MB / 142325760 blocks

IR Disk 1         Source Disk
Disk State        : Online
Slot ID           : 1
SAS WWID          : 5000C500-0134CB8D

IR Disk 0         Secondary Disk
Disk State        : Online
Slot ID           : 7
SAS WWID          : 5000C500-0134DBB5

IR Hot Spare      7
Hot Spare Status  : Active
Slot ID           : 6
SAS WWID          : 12210000-06000000
```

This example displays volume information and all physical disks corresponding to the IR volume set.

## **SHOW VERSION**

Displays the version number of the SAS utility that you are currently using.

### **Format**

SHOW VERSION

### **Example**

```
SAS> SHOW VERSION  
SAS$UTIL Version 1.0  
Build 05-May-2006
```

This example shows that this version of the SAS utility is 1.0.





---

## SCA Control Program Utility (SCACP)

### 6.1 SCACP Description

The SCA Control Program (SCACP) utility is designed to monitor and manage cluster communications. It is derived from the Systems Communications Architecture (SCA), which defines the communications mechanisms that allow nodes in an OpenVMS Cluster system to cooperate.

SCA does the following:

- Governs the sharing of data between resources at the nodes
- Binds together System Applications (SYSAPs) that run on different Integrity servers, Alpha, and VAX computers

Historically, LAN cluster port information has been available only in the System Dump Analyzer (SDA) utility and by using the Availability Manager management tool. The ability to start and stop PEdriver on a LAN device was provided by SYS\$EXAMPLES:SYS\$LAVC\_START\_BUS.EXE and SYS\$LAVC\_STOP\_BUS.EXE. No way existed to prioritize use of LAN devices or individual channels.

SCACP provides an alternative method of collecting cluster management data and exercising management control over cluster communications. OpenVMS Version 7.3 introduced SCACP's ability to manage SCA use of LAN paths. Beginning with OpenVMS Version 7.3-1, you can use SCACP to manage all OpenVMS Cluster interconnects.

Starting with OpenVMS Version 8.4, OpenVMS is enhanced to use IP (Internet Protocol) for cluster communications. OpenVMS cluster over IP (also referred to as IP Cluster Interconnect) is the ability to use TCP/IP stack for cluster communications in addition to LAN. PEdriver which implements the cluster communication protocol uses UDP (User datagram protocol) for cluster communication.

#### 6.1.1 Terminology Related to SCACP

Definitions of terms that are related to SCACP are in the following sections.

##### 6.1.1.1 SCS Ports and Circuits

SCA communications mechanisms between nodes are defined in terms of System Communications Services (SCS) ports and circuits:

- An **SCS port** is any device that provides SCA communications services.
- An **SCS circuit** is an SCS port layer connection that provides a standardized set of services using a reliable port-to-port communication connection between OpenVMS Cluster nodes.

After a circuit is formed between two ports, communication using the SCS services can be established between SYSAPs in the nodes. In a cluster, each port maintains a circuit with every other remote port.

## SCACP

### 6.1 SCACP Description

Circuits provide the SCS layer with the following standardized SCS services:

- Datagram delivery
- Message delivery
- Block data read and write operations

---

#### Note

---

Some differences exist in the use of the terms *paths* and *circuits*:

- The SCA architecture specification and OpenVMS code use the term **paths** to refer to *circuits*.
  - The SHOW CLUSTER utility and other OpenVMS utilities use the term **circuits** to refer to what SCA calls *paths*.
  - SCACP follows the SHOW CLUSTER precedent and uses the term **circuits** as well.
- 

#### 6.1.1.2 Virtual Circuits

A **virtual circuit** (VC) is the interconnect-specific transport layer connection within a circuit that provides reliable port-to-port communication. In other words, VCs are the details of a circuit concerned with interconnect-specific reliable data delivery.

Circuits ensure the following:

- The delivery of messages without duplication or loss
- The sequential ordering of messages

The concepts of circuits and virtual circuits are so closely related that usually it has been unnecessary to differentiate between them because SHOW CLUSTER provides no view of the internal operation of a circuit. SCACP, however, makes the differentiation necessary by providing this internal view.

If cluster over IP is enabled, the virtual circuit can consist of both LAN and IP channels for cluster communications. Beginning with OpenVMS Version 7.3, SCACP has been used to manage and display information about the VCs underlying the circuits between LAN ports. Because SCACP displays different types of information about circuits and VCs, its commands must differentiate between them.

LAN cluster communications create virtual circuits using the NI-SCA Transport Protocol to communicate over LAN hardware, providing datagram services.

Cluster over IP create virtual circuits using the NI-SCA Transport Protocol to communicate over IP network using UDP protocol.

#### 6.1.1.3 LAN Channels

A **channel** is a logical communication path between two LAN devices. Each channel between two nodes is determined by a local-remote pair of devices and the connecting network. For example, two nodes, each having two LAN devices, can establish up to four channels. The messages that a particular virtual circuit carries can be sent over any of the channels connecting the two nodes.

The LAN cluster driver, PEdriver, builds reliable virtual circuits using channels that the LAN adapters (devices) and the network connections define. It then uses these VCs to provide circuits to SCS.

#### 6.1.1.4 IP Channels

Starting from OpenVMS Version 8.4, with the OpenVMS cluster over IP support, a channel is also a logical path between two IP interfaces. Each channel between two nodes is determined by a local-remote pair of devices and the connecting network. For example, two nodes, each having two LAN devices, can establish up to four channels. Similarly two nodes each having two IP interfaces (for example, IE0 and IE1 in Node A and WE0 and WE1 in node B) can establish up to four channels (IE0-WE0, IE0-WE1, IE1-WE0, IE1-WE1). The messages that a particular virtual circuit carries can be sent over any of the channels connecting the two nodes.

The IP cluster driver, PEdriver, builds reliable virtual circuits using channels that the IP interfaces and the network connections define. It then uses these VCs to provide circuits to SCS.

#### 6.1.1.5 Channels and Virtual Circuits

The differences between channels and virtual circuits are the following:

- Channels are LAN or IP paths providing datagram service. In a LAN, the IEEE 802.3 protocol is used and in IP based communication UDP (User datagram protocol) is used.
- NI-SCA port-to-port virtual circuits are layered on channels and provide error-free paths between nodes.

Multiple channels can exist between nodes in an OpenVMS Cluster system, but only one LAN/IP -based virtual circuit can exist between any two nodes at a time.

---

**Note**

---

A virtual circuit can have both LAN and IP channels given that the two nodes can communicate using LAN as well as IP. However, by default the PE driver uses LAN channel for optimum performance.

---

### 6.1.2 New Cluster SCA Circuit and Port Functionality

The following sections explain more recent functionality available for SCA circuits and ports and more recent support for SCS dynamic load class.

#### 6.1.2.1 Ability to Set Port and Circuit Priorities

Beginning with OpenVMS Version 7.3-1, you have been able to exercise management control over the circuits chosen to be used for SCS connections. This control allows you to override the automatic selection of the circuit with the highest load class value.

To override automatic circuit selection, assign a management priority value to a specific circuit or SCA port. (A circuit's current priority value is the sum of the local port's management-assigned priority and the management priority value assigned to that circuit.)

Connections are assigned to a circuit with the highest priority. If multiple circuits have the highest priority value, then the circuit with the highest load class is selected.

## SCACP

### 6.1 SCACP Description

A change in a circuit's current priority has one of the following effects:

- If a circuit's new current priority value is higher than another circuit's current priority, the connection is moved to the circuit with the higher current priority.
- Similarly, if a circuit's new current priority value is lower than another circuit's current priority, the connection moves to the circuit with the highest current priority.

---

**CAUTION: Circuit Management Priority Is Volatile**

---

Whenever a circuit is closed, its management priority setting is lost. This is because the data structure containing information about a circuit is deallocated each time a circuit is closed. When a circuit is reopened, the structure is initialized with default values. Thus, circuit management priority does not propagate across VC closures.

---

#### 6.1.2.2 Ability to Enable/Disable PEdriver Checksumming

You can use SCACP to enable or disable checksumming on a per-VC basis. For example, in a disaster-tolerant cluster, you might want to enable only checksumming on VCs to nodes at the remote site to ensure that failure of a LAN/IP device's checksumming function resulting in corrupted packets does not propagate to the remote site.

#### 6.1.2.3 SCS Dynamic Load Class Support

Prior to OpenVMS Version 7.3-1, the load class of SCS circuits was determined only by the port's hard-coded load class value. As a result, CI or DSSI circuits were chosen over a Gigabit Ethernet circuit. Beginning with OpenVMS Version 7.3-1, PEdriver has dynamically updated the load class value of its SCS circuits to reflect the performance of the underlying LAN/IP path or paths currently in use.

If the circuits have the same priority, a change in a circuit's load class has one of the following effects:

- If a circuit's new load class value is higher than another circuit's current load class, the connection is moved to the higher load class circuit.
- Similarly, if a circuit's new load class value is lower than another circuit's load class, the connection moves to the circuit with the highest load class.

### 6.1.3 Managing Cluster Ports and Circuits

Beginning with V7.3-1, SCACP has provided the ability to display information about one cluster interconnect's local ports and their circuits with remote ports.

SCACP port and circuit data is intended to provide the information necessary to exercise management control over ports and circuits. SCACP is not intended to replace the copious data that SHOW CLUSTER provides for ports and circuits. The SHOW CLUSTER and SCACP utilities are intended to be used together to manage cluster communications.

SCACP port and circuit data show the following:

- SCACP port data shows an overview of a particular port's characteristics.

- SCACP circuit data shows the characteristics and the status of SCS communications with other nodes in the cluster.

You can also manage cluster communications by assigning a priority value to individual ports or circuits. See the SET CIRCUIT and SET PORT command descriptions.

#### 6.1.4 Managing LAN/IP Cluster Ports

To manage LAN/IP cluster ports, you can use common port and circuit commands. Additional commands exist for LAN/IP port VCs, channels, and LAN devices on nodes in the cluster, IP interfaces in nodes in the cluster:

- VC data shows detailed internal information about the characteristics and operation of the NI-SCA transport layer connection underlying the circuit between the local and remote PEdriver ports.
- Channel data shows the characteristics of each LAN/IP communications path and shows how suitable each channel is for use by the virtual circuit.
- LAN device data shows low-level local LAN device characteristics, counters, and errors.
- IP interface data shows lower level IP interface characteristics, counters, and errors.

SCACP allows you to set channel and LAN/IP device priority. SCACP also allows you to start and stop PEdriver on LAN devices or IP interfaces.

##### Using the PEdriver Event-Tracing Facility

The LAN/IP cluster port driver, PEdriver, includes an **event-tracing** facility that collects a small amount of information for each defined event and saves it in a buffer associated with the virtual circuit or channel. (Any event not associated with a particular virtual circuit or channel is saved in a global PEdriver trace buffer.)

The event trace data is used when debugging, performing dump analysis, and looking at detailed aspects of PEdriver operation.

---

**Note**

---

The TRACE commands are reserved for use by OpenVMS Engineering and HP Services under OpenVMS Engineering direction only. Trace commands and output are subject to change from release to release.

---

#### 6.1.5 Troubleshooting Cluster Communications

You can use SCACP to diagnose cluster communications problems. The appendix “Troubleshooting the NISCA Protocol” in *HP OpenVMS Cluster Systems* provides troubleshooting strategies to help cluster or network managers use SCACP and other tools to pinpoint network-related cluster communications problems.

#### 6.1.6 Related Documents

For additional information on the topics covered in this chapter, see the following documents:

- *HP OpenVMS Cluster Systems*
- *Guidelines for OpenVMS Cluster Configurations*

## SCACP

### 6.2 SCACP Usage Summary

### 6.2 SCACP Usage Summary

The SCA Control Program (SCACP) is a cluster management utility that performs certain privileged cluster communications management functions.

#### Format

```
RUN SYS$SYSTEM:SCACP
```

To invoke SCACP, enter the following command at the DCL prompt:

```
$ RUN SYS$SYSTEM:SCACP
```

SCACP displays the following prompt, at which you can enter SCACP commands using the standard rules of DCL syntax:

```
SCACP>
```

To exit SCACP and return to the DCL command level, enter the EXIT command at the SCACP> prompt or press Ctrl/Z.

---

#### Note

---

OpenVMS Version 7.3 and later require SYSPRV privilege to enter SCACP commands.

---

SCACP also requires the following privileges:

- A minimum of DISPLAY privilege is required to enter commands that display information or influence SCACP execution (that is, SHOW, HELP, SPAWN, EXIT, and so on.)
- SYSPRV privilege is required to enter commands that change cluster communications operations (that is, SET, START, and STOP).

#### Example

```
$ CREATE COUNT.COM
SHOW LAN DEVICE/COUNTERS
SPAWN WAIT 00:01:00
@COUNT
Ctrl/Z
$ RUN SYS$SYSTEM:SCACP
SCACP> @COUNT
```

This example creates and runs a command procedure, COUNT.COM, which displays device counters once a minute.

### 6.3 SCACP Commands

SCACP commands are provided for the following types of functions:

- Display
- Port selection
- Circuit selection
- Channel operation and selection

- LAN device/IP interface operation and selection
- Trace
- Miscellaneous: Help, Calculate, Spawn, Execute, and Exit

The SCACP commands are shown in Table 6–1.

**Table 6–1 SCACP Commands**

| Command                                    | Function  |
|--|---|
| <b>SCACP Display Commands Qualifiers</b>   |   |
| SHOW CHANNEL                               | Displays PEdriver channel information.  |
| SHOW CHANNEL/LAN                           | Displays PEDRIVER LAN channel information.  |
| SHOW CHANNEL/IP                            | Displays PEDRIVER IP channel information.   |
| SHOW CIRCUIT (nodename)                    | Shows information about all virtual circuits between this node and other cluster nodes. |
| SHOW LAN_DEVICE                            | Displays PEdriver LAN device information.   |
| SHOW PORT                                  | Displays information about all SCA ports on the node, including the LAN port, PEA0.     |
| SHOW VC                                    | Displays PEdriver virtual circuit information.  |
| <b>SCACP Operation Commands</b>            |   |
| SET CHANNEL                                | Allows a user to set PEdriver channel management options.                               |
| SET CIRCUIT                                | Allows a user to set a management priority value for the selected circuit or circuits.  |
| SET PORT                                   | Allows a user to set a management priority value for the selected port or ports.        |
| SET VC                                     | Allows a user to set PEdriver virtual circuit options.                                  |
| <b>SCACP LAN Device Operation Commands</b> |   |
| SET LAN_DEVICE                             | Sets PEdriver LAN device management options.  |
| START LAN_DEVICE                           | Starts PEdriver on the specified LAN devices.   |
| STOP LAN_DEVICE                            | Stops PEdriver on the specified LAN devices.  |
| <b>SCACP IP Device Operation Commands</b>  |   |
| SET IP_INTERFACE                           | Sets IP interface management priority parameter.  |
| SHOW IP_INTERFACE                          | Displays PEdriver device IP Interfaces data.  |
| START IP_INTERFACE                         | Starts PEdriver on the IP interface.  |
| STOP IP_INTERFACE                          | Stops PEdriver on the IP interface.   |

(continued on next page)

## SCACP

### 6.3 SCACP Commands

**Table 6–1 (Cont.) SCACP Commands**

| Command   | Function   |
|---|--|
| <b>SCACP Trace Commands</b>                         |  |
| <i>These commands are reserved for HP use only.</i> |  |
| SET TRACE   | Sets PEdriver event tracing options.   |
| SHOW TRACE  | Displays PEdriver event tracing information.   |
| START TRACE   | Displays PEdriver event tracing.   |
| STOP TRACE  | Stops PEdriver event tracing.  |
| <b>SCACP Miscellaneous Commands</b>                 |  |
| CALCULATE   | Calculates values you can use with SET commands to control OpenVMS cluster communications.   |
| HELP  | Displays help data.  |
| RELOAD  | This results in PEdriver refreshing the IP unicast address in PE\$IP_CONFIG.DAT file and transmits hello packet based on the list. This is used in IP clusters when a node is added to a cluster and IP unicast is used for cluster communication. All the existing members must have the IP address of new nodes for the node to join the cluster. This rule is applicable only if the new node has only IP channels for cluster communication. |
| SPAWN [command]                                     | Spawns and executes a DCL command.   |
| @filename   | Executes command file.   |
| EXIT  | Exits SCACP.   |



## CALCULATE

Calculates values you can use with SET commands to control OpenVMS Cluster communications. Currently, this command calculates the window size that can be used with the SET VC /WINDOW=TRANSMIT\_SIZE=value and SET VC /WINDOW=RECEIVE\_SIZE=value commands.

Parameters for calculating other values might be added in future releases.

### Format

CALCULATE Parameter

#### Parameters

##### **WINDOW\_SIZE**

Calculates a VC window size based on distance and aggregate line speed between two nodes.

#### Qualifiers

##### **/SPEED=linespeed**

Supplies the total speed in Megabits/Sec. of all LAN connections between two nodes to be used in calculating the window size.

##### **/DISTANCE=KILOMETERS [or =MILES]=distance**

Supplies the distance in kilometers or miles of the cable route between two nodes to be used in calculating the window size.

##### **/OPTIMIZE=LOCKING [or =IO]=distance**

Supplies the calculation with the type of intersite cluster communications to be optimized as follows:

- LOCKING indicates that the window size is to be optimized for lock messages that are relatively small, or for ICC communications using message sizes of up to a few hundred bytes.
- IO indicates that the window size is to be optimized for MSCP served IO, or for ICC communications using large messages.

#### Examples

1. SCACP> CALCULATE WINDOW\_SIZE /SPEED=1000/DISTANCE=KILOMETERS=500

The command in this example calculates the window size to be used between two nodes that are 500 kilometers apart, connected by a 1Gigabit/Second line speed. The command produces output similar to the following:

```
Calculate Window Size 2-JUN-2006 17:49:18.41:
Inter-node link DISTANCE:      500 KILOMETERS
Inter-node link SPEED:         1000 Mb/s
-----
Recommended WINDOW SIZE:      1024 frames
```

Note that the calculated window size is never smaller than the window size PEdriver automatically selects for the VC between two nodes, which is based solely on the reported local and remote line speeds. However, the calculated value is often larger because it includes packets stored in the inter-site link and the packet-size mix that the /OPTIMIZE qualifier enforces.

## SCACP EXIT

---

### EXIT

Stops execution of SCACP and returns control to the DCL command level. You can also enter Ctrl/Z at any time to exit.

### Format

EXIT

#### Parameters

None.

#### Qualifiers

None.

#### Example

```
SCACP> EXIT  
$
```

This command stops execution of SCACP and returns control to the DCL command level.

## HELP

Provides online help information about the SCACP utility.

### Format

HELP [topic]

#### Parameter

##### topic

Specifies a subject for which you want information: an SCACP command or a command plus a command keyword. If you enter the HELP command with a command name only, such as HELP SET, SCACP displays a list of all of the command keywords used with the SET command.

#### Qualifiers

None.

#### Example

```
SCACP> HELP SET TRACE
```

The HELP command in this example displays information about the SET TRACE command.

## SCACP RELOAD

---

### RELOAD

This results in PEdriver refreshing the IP unicast address in PE\$IP\_CONFIG.DAT file and transmits hello packet based on the list. This is used in IP clusters when a node is added to a cluster and IP unicast is used for cluster communication. All the existing members must have the IP address of new nodes for the node to join the cluster. This rule is applicable only if the new node has only IP channels for cluster communication.

### Format

RELOAD

#### Parameters

None.

#### Qualifiers

None.

## SET CHANNEL

Sets CHANNEL management parameters, currently limited to priority values.

---

**Note**

---

If a LAN device/IP interface is disabled for use by cluster communications, all channels associated with that device/interface are deleted. This means that all management settings for that device and its associated channels will be deleted.

---

### Format

SET CHANNEL nodename

#### Parameter

##### **nodename[,...]**

Includes channels to specific nodes, which you can use wildcards to specify. Each node name can be accompanied by optional qualifiers to specify local and remote device names. If no local or remote device name is specified, all channels to the specified node name are included.

Use the SHOW CHANNEL command to display node names and local and remote device names.

#### Qualifiers

##### **/EXCLUDE=(nodename[,...])**

Excludes channels to specific nodes, which you can use wildcards to specify. Each node name can be accompanied by optional qualifiers to specify local and remote device names. If no local or remote device name is specified, all channels associated with the specified node are included.

##### **/LOCAL\_DEVICE=(landvicename/IPinterfacename[,...])**

Specifies a LAN device/IP interface that identifies the local end of the channel; you can use wildcards to specify LAN devices/IP interfaces.

Use the SHOW CHANNEL command to display node names and local and remote device names, or use the SHOW LAN\_DEVICE/SHOW IP\_INTERFACE command to display device names.

##### **/PRIORITY=n**

Sets the management priority value for channels to selected nodes. *n* can be a value between -128 and +127. Suggested values are:

- 2 to cause channels to be preferred
- 2 to exclude channels

---

**Note**

---

A channel whose priority is -128 is not used for cluster communications. The priority of a LAN channel is the sum of the management priority assigned to the local LAN device and the channel itself. Similarly the priority of IP channel is the sum of the management priority assigned to local IP interface and channel itself. Therefore, you can assign any

## SCACP SET CHANNEL

combination of channel and LAN/IP device management priority values to achieve a total of -128.

---

### Caution

---

If you set the priority of all channels to -128, you totally disable use of the LAN/IP for cluster communication. This can cause the system to CLUEXIT.

---

#### **/REMOTE\_DEVICE=(landvicename/IPinterfacename[,...])**

Specifies a LAN device/IP interface that identifies the remote end of the channel; you can use wildcards to specify LAN/IP devices.

Use the SHOW CHANNEL command to display node names and local and remote device names, or use the SHOW LAN\_DEVICE/SHOW IP\_INTERFACE command to display device names.

Use the SHOW LAN\_DEVICE/SHOW IP\_INTERFACE command on the remote node to display remote device names.

#### **Examples**

1. SCACP> SET CHANNEL/PRIORITY=3 NODE5

The command in this example sets the priorities of all channels to node NODE5 to 3.

2. SCACP> SET CHANNEL/LOCAL=EWA/REMOTE=EWB -  
\_SCACP> NODE10,NODE15/L=F\*/R=F\*,NODE20/PRIORITY=10

The command in this example is equivalent to the following command:

```
SET CHANNEL NODE10/L=EWA/R=EWB,NODE15/L=F*/R=F*,NODE20/L=*/R:*/PRIORITY=10
```

This command sets the priority of the following channels to 10:

- To node NODE10, the channel with local LAN device EWA and remote device EWB
  - To node NODE15, the channels with local LAN devices starting with F and remote LAN devices starting with F
  - All channels to node NODE20
3. SCACP> SET CHANNEL/LOCAL=WE0/REMOTE=IE0/PRIORITY=10 NODE20

This command sets priority of IP channel whose local interface is WE0 and remote interface is IE0 to 10.

### Note

---

A node can have both LAN and IP channels with a remote node. In such a scenario, by default, the PEdriver uses LAN channel for cluster communications. However, you can override this by using SET CHANNEL/PRIORITY and assign a higher priority to IP channels over LAN channels.

---

---

## SET CIRCUIT

Sets the circuit management priority value.

---

### Note

If a circuit is closed, it is deleted. This means that the management settings for that circuit are also deleted. If the circuit is opened again, it has the default values for its management settings.

---

## Format

SET CIRCUIT nodename

### Parameter

#### **nodename[,...]**

Names a circuit or circuits to specific nodes, which you can use wildcards to specify. You can qualify each node name with additional parameters to uniquely identify a single circuit.

### Qualifiers

#### **/EXCLUDE=(nodename[/PORT=portname[/RSTATION=n]][,...])**

Allows you to exclude a specific circuit to a node. If multiple circuits to the same node exist, you can use the /PORT and /RSTATION qualifiers to uniquely identify the circuit.

#### **/PORT=portname[/RSTATION=n]**

If multiple circuits to the same node exist, you can use the /PORT and /RSTATION qualifiers to uniquely identify the circuit. You can use the /RSTATION qualifier only in conjunction with the /PORT qualifier.

### Example

```
SCACP> SET CIRCUIT CLUI01 /PORT=PIB0 /PRI=10
```

The command in this example sets the priority of the circuit to node CLUI01 through PIB0 to 10. You need to use the /PORT qualifier if multiple circuits to node CLUI01 exist and only the circuit through PIB0 is meant to have its priority raised.

## SCACP SET IP\_INTERFACE

---

### SET IP\_INTERFACE

Sets IP interface management priority parameter.

#### Format

```
SET IP_INTERFACE ipinterface
```

#### Parameter

##### **ipinterface[,...]**

Includes one or more specific IP interface, which you can use wildcards to specify.

- Use the /EXCLUDE qualifier to exclude an IP interface.
- Use the SHOW IP\_INTERFACE command to display device names.

#### Qualifiers

##### **/EXCLUDE=(ipinterface1[,...])**

Excludes one or more specific IP interface which you can use wildcards to specify.

##### **/PRIORITY=*n***

Sets the management priority value for the selected interfaces. *n* can be a value between -128 and +127. Suggested values are:

- 2 to cause devices to be preferred
- -2 to exclude devices

---

#### Note

---

A channel whose priority is -128 is not used for cluster communications. The priority of a channel is the sum of the management priority assigned to the IP interface and the channel itself. Therefore, you can assign any combination of channel and IP interface management priority values to achieve a total of -128.

---

---

#### Caution

---

If you set the priority of all devices to -128, you totally disable use of the IP for cluster communication. This can cause the system to CLUEXIT.

---

#### Example

```
SCACP> SET IP_INTERFACE/PRIORITY=3 WE0
```

The command in this example sets the management priority for device WE0 to 3.



---

## SET LAN\_DEVICE

Sets device management priority parameter.

### Format

SET LAN\_DEVICE landevicename

#### Parameter

**landevicename[...]**

Includes specific LAN devices, which you can use wildcards to specify.

Use the /EXCLUDE qualifier to exclude LAN devices.

Use the SHOW LAN\_DEVICE command to display device names.

#### Qualifiers

**/EXCLUDE=(landevicename1[...])**

Excludes one or more specific LAN devices, which you can use wildcards to specify.

**/PRIORITY=n**

Sets the management priority value for the selected devices. *n* can be a value between -128 and +127. Suggested values are:

- 2 to cause devices to be preferred
- -2 to exclude devices

---

#### Note

The channel whose priority is -128 is not used for cluster communications. The priority of a channel is the sum of the management priority assigned to the local LAN device and the channel itself. Therefore, you can assign any combination of channel and LAN device management priority values to achieve a total of -128.

---

#### Caution

If you set the priority of all devices to -128, you totally disable use of the LAN for cluster communication. This can cause the system to CLUEXIT.

### Example

```
SCACP> SET LAN_DEVICE/PRIORITY=3 EWA
```

The command in this example sets the management priority for device EWA to 3.

## SET PORT

Sets a port management priority value.

### Format

SET PORT portname

#### Parameter

**portname[,...]**

Specifies SCA port names, in which you can include wildcards.

Use the /EXCLUDE qualifier to exclude specific ports.

Use the SHOW PORT command to display all ports available on your system.

#### Qualifiers

**/EXCLUDE=(portname[,...])**

Excludes specific ports from the operation.

**/PRIORITY=*n***

Sets the management priority value for the selected ports. *n* can be any value between -128 and +127.

#### Examples

1. SCACP> SET PORT PEA0/PRIORITY=5

The command in this example sets the management priority for the PEA0 port to 5.

2. SCACP> SET PORT PEA0 /PRIORITY=5 /EXCLUDE=PEA0

The command in this example sets all ports with the exception of PEA0 to a management priority of 5.

---

## SET TRACE

SET TRACE sets or modifies PEdriver tracing parameters.

---

### Note

This command is reserved for use by HP Services and OpenVMS Engineering only. Trace commands and output are subject to change from release to release.

---

## Format

SET TRACE nodename

### Parameter

#### **nodename[,...]**

Includes channels and VCs to specific nodes, which you can use wildcards to specify. Each node name can be accompanied by optional qualifiers to specify local and remote device names.

If no local or remote device name is specified, all channels associated with the specified node are included, as well as the VC to the specified node.

Use the SHOW CHANNEL command to display node names and local and remote device names.

### Qualifiers

#### **/AFTER=*n***

After the trace stop condition has been satisfied, continue tracing for *n* events, and then stop. If you do not specify /AFTER, tracing does not continue after the trace stop event. *n* can be any value between 0 and FFFFFFFF.

#### **/DEFAULT**

Sets the trace context back to the default settings, which are:

```
trace all channels and VCs
/AFTER=0
/EVENT=default settings
/STOP
/SIZE=512
```

#### **/EVENT=(event1[,...])**

Enables tracing on specific events, which you can use wildcards to specify. The default is a subset of the events, which includes most errors and state changes when the system parameter SYSTEM\_CHECK is set to 0. The default is “all events included” when SYSTEM\_CHECK is set to 1.

Use the SHOW TRACE/CONTEXT command to display event names.

#### **/EXCLUDE=(nodename[/LOCAL\_DEVICE=landevicename/ipinterfacename] [/REMOTEDEVICE=landevicename/ipinterfacename][,...])**

Excludes VCs or channels, or both, to specific nodes, which you can use wildcards to specify. Each node name can be accompanied by optional qualifiers to specify local and remote device names. If no local or remote device name is specified, the VC and all channels associated with the specified node are excluded.

## SCACP SET TRACE

### **/LOCAL\_DEVICE=(landevicename/ipinterfacename[,...])**

Includes specific LAN devices that identify the local end of the channel. You can use wildcards to specify LAN devices.

### **/REMOTE\_DEVICE=(landevicename/ipinterfacename[,...])**

Includes specific LAN devices that identify the remote end of the channel; you can use wildcards to specify LAN devices.

Use the SHOW LAN\_DEVICE command to display device names.

### **/STOP=(event1[,...])**

Stops tracing on specific events, which you can use wildcards to specify. The default is “no events included.”

Use the SHOW TRACE/CONTEXT command to display event names.

### **/SIZE=n**

Specifies a trace buffer size of *n* bytes to be used by PEdriver for each trace buffer: one for global PEdriver use, one for each selected channel, and one for each selected VC. *n* can be any value between 0 and FFFFFFFF.

## Examples

1. SCACP> SET TRACE/EVENT=CC\_STATE/SIZE=1000

The command in this example specifies that the trace buffers for each channel, VC, and the global buffer each be 1000 bytes in length.

2. SCACP> SET TRACE/EVENT=\* NODE10/LOCAL=EWA,NODE20

The command in this example specifies that all events are to be recorded; when applicable to a particular node, however, only channels and VCs to nodes NODE10 and NODE20 are to be included.

3. SCACP> SET TRACE/EVENT=(ALL,NOTIMER) NODE10

The command in this example specifies that all events except timer events on node NODE10 are to be included.

4. SCACP> SET TRACE/LOCAL=EWA/REMOTE=EWB  
NODE10,NODE15/L=F\*/R=F\*,NODE20

The command in this example is equivalent to the following command:

```
SET TRACE NODE10/L=EWA/R=EWB,NODE15/L=F*/R=F*,NODE20/L=EWA/R:EWB
```

The command in the example sets tracing on the following channels:

- On node NODE10, channels with local device EWA and remote device EWB
- On node NODE15, channels with local LAN device starting with F and remote LAN device starting with F
- On node NODE20, channels with local LAN device EWA and remote LAN device EWB

---

## SET VC

Sets values for the virtual circuit management parameters (checksumming, compression, ECS delay threshold, transmit window size, and receive window size values).

### Format

SET VC nodename

#### Parameter

**nodename[,...]**

Includes VCs to specific nodes, which you can use wildcards to specify.

Use the /EXCLUDE qualifier to exclude VCs to specific nodes.

Use the SHOW CHANNEL or SHOW VC command to display VC names, which are simply the names of remote nodes.

#### Qualifiers

**/CHECKSUMMING**

**/NOCHECKSUMMING**

Enables or disables checksum verification on the selected VCs to the specified nodes.

You can use this command alone or in combination with the system parameter NISCS\_PORT\_SERV. (For more information, see online help for NISCS\_PORT\_SERV.)

Note that the the SET VC/CHECKSUMMING setting is not valid beyond the life of the system. Therefore, you might want to include SET VC/CHECKSUMMING commands in your startup file, or reissue these commands at the next boot.

**/COMPRESSION**

**/NOCOMPRESSION**

Enables or disables sending compressed data by the specified VCs. The default is /NOCOMPRESSION.

Usage notes:

- Compression is used only if the partner node has a PEdriver version that supports it.
- You can also enable the use of compression with the NISCS\_PORT\_SERV system parameter. For more information about NISCS\_PORT\_SERV, see the System Parameter appendix in this manual.
- The /NOCOMPRESSION qualifier does not override compression enabled by setting bit 2 of NISCS\_PORT\_SERV.

**/ECS\_MAX\_DELAY=n**

**/NOECS\_MAX\_DELAY**

Sets a management-specified lower bound on the maximum delay (in microseconds) an ECS member channel can have. The value for *n* can be any value between 0 and 3000000. /NOECS\_MAX\_DELAY disables a prior management delay setting.

## SCACP SET VC

You can use this command to override the PEdriver automatically calculated delay thresholds to ensure that all channels with delays less than the value supplied for *n* are included in the VC's ECS.

The command operates as follows: Whenever at least one tight peer channel has a delay of less than the management-supplied value, all tight peer channels with delays less than the management-supplied value are automatically included in the ECS. When all tight peer channels have delays equal to or greater than the management setting, the ECS membership delay thresholds are automatically calculated and used. The `/NOECS_MAX_DELAY` qualifier disables management control by setting the management delay value to zero.

You must determine an appropriate value for your configuration by experimentation. An initial value of 2000 (2 ms) to 5000 (5 ms) is suggested.

---

### CAUTION

---

By overriding the automatic delay calculations, you can include a channel in the ECS whose average delay is consistently greater than 1.5 to 2 times the average delay of the fastest channels. When this occurs, the overall VC throughput becomes the speed of the slowest ECS member channel.

An extreme example is when the management delay permits a 10 Mb/s Ethernet channel to be included with multiple 1 Gb/s channels. The resultant VC throughput drops to 10 Mb/s.

---

Note that the `SET VC/ECS_MAX_DELAY` setting is not valid beyond the life of the system. Therefore, you might want to include `SET VC/ECS_MAX_DELAY` commands in your startup file or reissue these commands at the next boot.

#### **/EXCLUDE=(nodename[,...])**

Excludes VCs to specific nodes, which you can use wildcards to specify.

#### **/WINDOW=RECEIVE=*n***

#### **/WINDOW=NORECEIVE**

Sets a management-specified upper bound on the receive window size (that is, the number of out-of-order packets this VC holds in its resequencing cache while awaiting the next in-order packet or packets).

You can use this qualifier to override the automatically calculated receive window size. This ensures that the VC has enough buffering to receive the expected maximum number of out-of-order packets.

Usage notes:

- The window size value *n* must be an exact power of 2.  
Never use settings that cause the receive window of a VC to be smaller than the transmit window of the partner node. Otherwise, the partner can send packets that cannot be cached when a packet is lost. This results in unnecessary retransmissions, and might cause channels not to be used because they become “lossy.” This leads to the remaining restrictions listed.
- Always decrease the transmit window size of a VC's partner node before decreasing a VC's receive window size.  
HP recommends using `SYSMAN` to decrease both the local and the remote VC transmit window sizes before increasing the local and remote receive window sizes (as shown in the example).

- Always increase the receive window size of a VC's partner node before increasing a VC's transmit window size.

HP recommends using SYSMAN to increase both the local and the remote VC receive window sizes before increasing the local and remote transmit window sizes.

- Whenever you enter the SET VC/WINDOW=RECEIVE command, the following sequence of events occurs:
  1. The VC's current resequencing cache is emptied.
  2. The VC partner node automatically retransmits any discarded packets.
  3. As a result of 2, the VC and channel retransmit counts increase.
  4. A few messages similar to the following might be displayed, indicating that one or more channels has temporarily become "lossy":
 

```
%PEA0, Excessive packet losses on LAN Path from EWA to EWC
on REMOTE NODE STAR
```
  5. The partner node recovers automatically within a few seconds.
- You can use the SCACP> CALCULATE WINDOW\_SIZE command to assist you in selecting the size to use for transmit and receive windows.

**/WINDOW=TRANSMIT=*n***

**/WINDOW=NOTRANSMIT**

Sets a management-specified upper bound on the transmit window size (that is, the number of out-of-order packets this VC sends while awaiting acknowledgment of the transmitted packets) to *n*. The /WINDOW=NOTRANSMIT qualifier resumes automatic control of the window size and changes the management transmit window size to zero.

You can use the /WINDOW=TRANSMIT qualifier to override the automatically calculated transmit window size to ensure that the VC has enough buffering to receive the expected maximum number of out-of-order packets.

Usage notes:

- The window size value *n* must be an exact power of 2.  
 Never use settings that cause the receive window of a VC to be smaller than the transmit window of the partner node. Otherwise, the partner can send packets that cannot be cached when a packet is lost. This results in unnecessary retransmissions, and might cause channels not to be used because they become "lossy". This leads to the following restrictions.
- Always decrease the transmit window size of a VC's partner node before decreasing a VC's receive window size.  
 HP recommends using SYSMAN to decrease both the local and the remote VC transmit window sizes before increasing the local and remote receive window sizes.
- Always increase the receive window size of a VC's partner node before increasing a VC's transmit window size.  
 HP recommends using SYSMAN to increase both the local and the remote VC receive window sizes before increasing the local and remote transmit window sizes (as shown in the example).

## SCACP SET VC

- You can use the SCACP CALCULATE WINDOW\_SIZE command to assist you in selecting the size to be used for transmit and receive windows.

### Examples

```
1. $RUN SYS$SYSTEM:SYSMAN
SYSMAN> SET ENV/NODE=LARRY
DO MC SCACP SET VC LARRY/WINDOW=TRANSMIT=16
SET ENV/NODE=CURLY
DO MC SCACP SET VC CURLY/WINDOW=TRANSMIT=16
SET ENV/NODE=LARRY
DO MC SCACP SET VC LARRY/WINDOW=RECEIVE=16
SET ENV/NODE=CURLY
DO MC SCACP SET VC CURLY/WINDOW=RECEIVE=16
EXIT
```

This example shows how to decrease window size. The transmit and receive window sizes are 32 on both nodes, and the commands decrease the window size for the VC between LARRY and CURLY. (You can enter the commands on either node.)

```
2. $RUN SYS$SYSTEM:SYSMAN
SYSMAN> SET ENV/NODE=LARRY
DO MC SCACP SET VC LARRY/WINDOW=RECEIVE=64
SET ENV/NODE=CURLY
DO MC SCACP SET VC CURLY/WINDOW=RECEIVE=64
SET ENV/NODE=LARRY
DO MC SCACP SET VC LARRY/WINDOW=TRANSMIT=64
SET ENV/NODE=CURLY
DO MC SCACP SET VC CURLY/WINDOW=TRANSMIT=64
EXIT
```

This example shows how to increase window size. The transmit and receive window sizes are 32 on both nodes, and the commands increase the window size for the VC between LARRY and CURLY. (You can enter the commands on either node.)



---

## SHOW CHANNEL

Displays PEdriver channel information for specific nodes. Each channel is a single NISCA communications path between a LAN device on a local system and a LAN device on a remote system.

Use the SHOW CHANNEL command to display node names and local and remote device names.

### Format

SHOW CHANNEL nodename

#### Parameter

##### **nodename[,...]**

Includes channels to specific nodes, which you can use wildcards to specify.

Each node name can be accompanied by optional qualifiers to specify local and remote device names. If no local or remote device name is specified, all channels associated with the specified node name are included.

#### Qualifiers

##### **/ALL**

Includes all channel data.

##### **/COUNTERS**

Includes channel counters data.

##### **/ECS**

##### **/NOECS**

Includes only channels that are (or are not) members of the ECS.

##### **/EXCLUDE=(nodename[,...])**

Excludes channels to specific nodes, which you can use wildcards to specify.

Each node name can be accompanied by optional qualifiers to specify local and remote device names. If no local or remote device name is specified, all channels associated with the specified node are included.

##### **/INTERVAL**

For the /COUNTERS display, displays the changes to counters since the last SHOW command.

##### **/IP**

Includes the IP channel data.

##### **/LAN**

Includes the LAN channel data.

##### **/LOCAL\_DEVICE=(landevicename/IPinterfacename[,...])**

Includes specific LAN devices that identify the local end of the channel; you can use wildcards to specify LAN devices.

Use the SHOW LAN\_DEVICE command to display device names.

##### **/n**

Displays the *n*th page. To select a particular page of a multipage display, specify the number of the page you want to display.

## SCACP SHOW CHANNEL

### **/OUTPUT=filespec**

Creates the specified file and directs output to it.

### **/REMOTE\_DEVICE=(landevicename/IPinterfacename[,...])**

Includes specific LAN devices/IP interfaces that identify the remote end of the channel; you can use wildcards to specify LAN devices/IP interfaces.

Use the SHOW LAN\_DEVICE command to display device names.

### **/SDA**

Includes channel data displayed in SDA format, with all the data collected in one display for one channel.

### **/SUMMARY**

Includes channel summary data. This is the default if /ALL, /COUNTERS, and /SDA qualifiers are not specified.

### **Examples**

1. SCACP> SHOW CHANNEL NODE20/LOCAL=EWA

The command in this example displays channel definition data for all nodes defined with local device EWA and any remote device and remote node name starting with NODE20.

2. SCACP> SHOW CHANNEL/COUNTERS/INTERVAL  
SCACP> SPAWN WAIT 0:0:10  
SCACP> SHOW CHANNEL/COUNTERS/INTERVAL

The first command in this example displays channel counters since the last SHOW command. The SPAWN command tells the DCL WAIT command to insert a 10-second delay. The second SHOW CHANNEL command displays counters after the 10-second period.

3. SCACP> SHOW CHANNEL/1/3

The command in this example displays the first and third pages of data for all channels. The first page contains Channel Summary data, and the third page contains Channel Equivalent Channel Set (ECS) data.

4. SCACP> SHOW CHANNEL/ALL

The following is a snapshot of the output for SHOW CHANNEL/ALL command.

# SCACP SHOW CHANNEL

MADDY\$ MC SCACP SHOW CHANNEL/ALL

MADDY PEA0 Channel Summary 15-FEB-2009 12:08:24.16:

| Remote Node | Device Loc Rmt | Channel State | Total Errors | ECS State | Priority Cur Mgt | Buffer Hops Size | Delay (uSec) | Load Class | Total Pkts(S+R) | CH Opened          | Time      | Most Recent CH Closed | Time |
|-------------|----------------|---------------|--------------|-----------|------------------|------------------|--------------|------------|-----------------|--------------------|-----------|-----------------------|------|
| ORCHID      | WE0 IE0        | Open          | 57           | Y(T,P,F)  | 0 0              | 2 1394           | 4198.4       | 100        | 1831428         | 14-FEB 11:35:11.54 | (No time) |                       |      |
| TULIP       | WE0 IE0        | Open          | 1            | N(T,I,F)  | 0 0              | 2 1394           | 250.0        | 100        | 196042          | 14-FEB 11:35:12.05 | (No time) |                       |      |
| TULIP       | EIA EIA        | Open          | 1            | Y(T,P,F)  | 0 0              | 2 1426           | 496.2        | 100        | 634047          | 14-FEB 11:34:46.92 | (No time) |                       |      |
| TULIP       | EIA EIB        | Open          | 1            | Y(T,P,F)  | 0 0              | 2 1426           | 546.0        | 100        | 444646          | 14-FEB 11:34:45.04 | (No time) |                       |      |
| TULIP       | EWA EIA        | Open          | 0            | Y(T,P,F)  | 0 0              | 2 1426           | 521.6        | 1000       | 675722          | 14-FEB 11:34:38.06 | (No time) |                       |      |
| TULIP       | EWA EIB        | Open          | 1            | Y(T,P,F)  | 0 0              | 2 1426           | 514.9        | 1000       | 503848          | 14-FEB 11:34:38.06 | (No time) |                       |      |
| JASMIN      | WE0 IE1        | Open          | 1            | N(T,I,F)  | 0 0              | 2 1394           | 250.0        | 100        | 154648          | 14-FEB 11:35:12.10 | (No time) |                       |      |
| JASMIN      | EIA EIA        | Open          | 1            | Y(T,P,F)  | 0 0              | 2 1426           | 455.7        | 100        | 471521          | 14-FEB 11:34:46.04 | (No time) |                       |      |
| JASMIN      | EIA EIB        | Open          | 1            | Y(T,P,F)  | 0 0              | 2 1426           | 450.3        | 100        | 434176          | 14-FEB 11:34:45.04 | (No time) |                       |      |
| JASMIN      | EWA EIB        | Open          | 1            | Y(T,P,F)  | 0 0              | 2 1426           | 457.4        | 100        | 471021          | 14-FEB 11:34:39.25 | (No time) |                       |      |
| JASMIN      | EWA EIA        | Open          | 1            | Y(T,P,F)  | 0 0              | 2 1426           | 423.7        | 100        | 547601          | 14-FEB 11:34:38.84 | (No time) |                       |      |
| MADDY       | EWA EIA        | Open          | 1            | Y(T,P,F)  | 0 0              | 2 1426           | 250.0        | 100        | 156529          | 14-FEB 11:34:45.04 | (No time) |                       |      |
| MADDY       | EIA EWA        | Open          | 1            | Y(T,P,F)  | 0 0              | 2 1426           | 250.0        | 100        | 156218          | 14-FEB 11:34:45.04 | (No time) |                       |      |
| MADDY       | LCL LCL        | Open          | 3            | Y(T,P,F)  | 0 0              | 2 1426           | 246.9        | 0          | 155833          | 14-FEB 11:34:38.62 | (No time) |                       |      |

MADDY PEA0 Channel Miscellaneous 15-FEB-2009 12:08:24.16:

| Remote Node | LAN/IP Local | Device Remote | Local LAN/IP Address | Remote LAN/IP Address | Cur  | Neg  | Buffer Mgt | Size Loc Rmt | Change | -Seq. Local | Number-- Remote |
|-------------|--------------|---------------|----------------------|-----------------------|------|------|------------|--------------|--------|-------------|-----------------|
| ORCHID      | WE0          | IE0           | 15.146.235.10        | 16.138.182.6          | 1394 | 1394 | 8120       | 1394         | 1394   | 1           | 1 2             |
| TULIP       | WE0          | IE0           | 15.146.235.10        | 15.146.235.222        | 1394 | 1394 | 8120       | 1394         | 1394   | 1           | 1 2             |
| TULIP       | EIA 82559    | EIA           | 00-30-6E-4A-13-3F    | 00-17-08-7C-B9-16     | 1426 | 1426 | 8120       | 1426         | 1426   | 1           | 1 2             |
| TULIP       | EIA 82559    | EIB           | 00-30-6E-4A-13-3F    | 00-17-08-7C-B9-17     | 1426 | 1426 | 8120       | 1426         | 1426   | 1           | 1 2             |
| TULIP       | EWA EIA      | EIA           | 00-30-6E-4A-02-F9    | 00-17-08-7C-B9-16     | 1426 | 1426 | 8120       | 1426         | 1426   | 1           | 1 2             |
| TULIP       | EWA EIB      | EIB           | 00-30-6E-4A-02-F9    | 00-17-08-7C-B9-17     | 1426 | 1426 | 8120       | 1426         | 1426   | 1           | 1 2             |
| JASMIN      | WE0          | IE1           | 15.146.235.10        | 15.146.235.19         | 1394 | 1394 | 8120       | 1394         | 1394   | 1           | 1 2             |
| JASMIN      | EIA 82559    | EIA 82558     | 00-30-6E-4A-13-3F    | 00-08-02-3E-92-10     | 1426 | 1426 | 8120       | 1426         | 1426   | 1           | 1 2             |
| JASMIN      | EIA 82559    | EIB 82558     | 00-30-6E-4A-13-3F    | 00-08-02-3E-92-11     | 1426 | 1426 | 8120       | 1426         | 1426   | 1           | 1 2             |
| JASMIN      | EWA          | EIB 82558     | 00-30-6E-4A-02-F9    | 00-08-02-3E-92-11     | 1426 | 1426 | 8120       | 1426         | 1426   | 1           | 1 2             |
| JASMIN      | EWA          | EIA 82558     | 00-30-6E-4A-02-F9    | 00-08-02-3E-92-10     | 1426 | 1426 | 8120       | 1426         | 1426   | 1           | 1 2             |
| MADDY       | EWA          | EIA 82559     | 00-30-6E-4A-02-F9    | 00-30-6E-4A-13-3F     | 1426 | 1426 | 8120       | 1426         | 1426   | 1           | 1 1             |
| MADDY       | EIA 82559    | EWA           | 00-30-6E-4A-13-3F    | 00-30-6E-4A-02-F9     | 1426 | 1426 | 8120       | 1426         | 1426   | 1           | 1 1             |
| MADDY       | LCL          | LCL           | 00-00-00-00-00-00    | 00-00-00-00-00-00     | 1426 | 1426 | 8120       | 1426         | 1426   | 1           | 1 1             |

MADDY PEA0 Channel Equivalent Channel Set (ECS) 15-FEB-2009 12:08:24.16:

| Remote Node | Device Loc Rmt | ECS State | ECS Losses | ECS Transitions | Average RTTTime | Remote Ring Size | Remote Rcv Cache | Time in Open State | ECS Member Time |
|-------------|----------------|-----------|------------|-----------------|-----------------|------------------|------------------|--------------------|-----------------|
| ORCHID      | WE0 IE0        | Y(T,P,F)  | 0          | 19              | 4198.4          | 8                | 32               | 00:33:12.62        | 00:33:12.62     |
| TULIP       | WE0 IE0        | N(T,I,F)  | 0          | 0               | 250.0           | 8                | 64               | 00:33:12.10        | (No time)       |
| TULIP       | EIA EIA        | Y(T,P,F)  | 0          | 2191            | 496.2           | 128              | 64               | 00:33:37.23        | 18:34:24.66     |
| TULIP       | EIA EIB        | Y(T,P,F)  | 0          | 2107            | 546.0           | 128              | 64               | 00:33:39.11        | 18:37:21.38     |
| TULIP       | EWA EIA        | Y(T,P,F)  | 0          | 2153            | 521.6           | 128              | 64               | 00:33:46.09        | 18:59:29.32     |
| TULIP       | EWA EIB        | Y(T,P,F)  | 0          | 2243            | 514.9           | 128              | 64               | 00:33:46.09        | 18:32:49.40     |
| JASMIN      | WE0 IE1        | N(T,I,F)  | 0          | 0               | 250.0           | 8                | 32               | 00:33:12.05        | (No time)       |
| JASMIN      | EIA EIA        | Y(T,P,F)  | 0          | 1541            | 455.7           | 32               | 32               | 00:33:38.11        | 21:47:05.88     |
| JASMIN      | EIA EIB        | Y(T,P,F)  | 0          | 1511            | 450.3           | 32               | 32               | 00:33:39.11        | 21:53:49.76     |
| JASMIN      | EWA EIB        | Y(T,P,F)  | 0          | 1417            | 457.4           | 32               | 32               | 00:33:44.91        | 21:54:41.59     |
| JASMIN      | EWA EIA        | Y(T,P,F)  | 0          | 1359            | 423.7           | 32               | 32               | 00:33:45.32        | 21:56:30.43     |
| MADDY       | EWA EIA        | Y(T,P,F)  | 0          | 3               | 250.0           | 32               | 32               | 00:33:39.11        | 00:32:39.68     |
| MADDY       | EIA EWA        | Y(T,P,F)  | 0          | 3               | 250.0           | 128              | 32               | 00:33:39.11        | 00:32:43.68     |
| MADDY       | LCL LCL        | Y(T,P,F)  | 0          | 1               | 246.9           | 8                | 32               | 00:33:45.53        | 00:33:45.53     |

MADDY PEA0 Channel Counters and Errors 15-FEB-2009 12:08:24.16:

| Remote Node | Device Loc Rmt | -- Transmit -- Messages | Bytes     | -- Receive -- Messages | Bytes     | Xmt:Rexmit | Rexmit Errors | TransmitFail Penalties | Receive Errors | Other Errors |
|-------------|----------------|-------------------------|-----------|------------------------|-----------|------------|---------------|------------------------|----------------|--------------|
| ORCHID      | WE0 IE0        | 805782                  | 142672600 | 1025646                | 430448532 | 14389      | 56            | 0                      | 1              | 0            |
| TULIP       | WE0 IE0        | 58927                   | 6129756   | 137115                 | 14261308  | 58927      | 1             | 0                      | 0              | 0            |
| TULIP       | EIA EIA        | 236620                  | 45342464  | 397427                 | 184255260 | 236620     | 1             | 0                      | 0              | 0            |
| TULIP       | EIA EIB        | 229440                  | 43549741  | 215206                 | 71208495  | 229440     | 1             | 0                      | 0              | 0            |
| TULIP       | EWA EIA        | 244550                  | 46781318  | 431172                 | 181262983 | Infinite   | 0             | 0                      | 0              | 0            |
| TULIP       | EWA EIB        | 225133                  | 42441919  | 278715                 | 121749892 | 225133     | 1             | 0                      | 0              | 0            |
| JASMIN      | WE0 IE1        | 58198                   | 6053940   | 96450                  | 10032148  | 58198      | 1             | 0                      | 0              | 0            |
| JASMIN      | EIA EIA        | 212355                  | 39590192  | 259166                 | 90998564  | 212355     | 1             | 0                      | 0              | 0            |
| JASMIN      | EIA EIB        | 196205                  | 36172035  | 237971                 | 80468129  | 196205     | 1             | 0                      | 0              | 0            |
| JASMIN      | EWA EIB        | 212469                  | 39677191  | 258552                 | 90156844  | 212469     | 1             | 0                      | 0              | 0            |
| JASMIN      | EWA EIA        | 213187                  | 40135661  | 334414                 | 128234144 | 213187     | 1             | 0                      | 0              | 0            |
| MADDY       | EWA EIA        | 58944                   | 6131556   | 97585                  | 10150220  | 58944      | 1             | 0                      | 0              | 0            |
| MADDY       | EIA EWA        | 58945                   | 6131660   | 97273                  | 10117772  | 58945      | 1             | 0                      | 0              | 0            |
| MADDY       | LCL LCL        | 58956                   | 6132702   | 96877                  | 10076486  | Infinite   | 0             | 0                      | 0              | 3            |

MADDY PEA0 Channel Errors 15-FEB-2009 12:08:24.16:

| Remote Node | Device Loc Rmt | Bad | Auth | Bad ECO | Bad MCA | Receive Short | Incompat | Old chan | Timeouts Handshake | -- Listen | No MSCP Server | Disk Not Served | Path Restart |
|-------------|----------------|-----|------|---------|---------|---------------|----------|----------|--------------------|-----------|----------------|-----------------|--------------|
| ORCHID      | WE0 IE0        | 1   | 0    | 0       | 0       | 0             | 0        | 0        | 0                  | 0         | 0              | 0               | 0            |
| TULIP       | WE0 IE0        | 0   | 0    | 0       | 0       | 0             | 0        | 0        | 0                  | 0         | 0              | 0               | 0            |
| TULIP       | EIA EIA        | 0   | 0    | 0       | 0       | 0             | 0        | 0        | 0                  | 0         | 0              | 0               | 0            |
| TULIP       | EIA EIB        | 0   | 0    | 0       | 0       | 0             | 0        | 0        | 0                  | 0         | 0              | 0               | 0            |
| TULIP       | EWA EIA        | 0   | 0    | 0       | 0       | 0             | 0        | 0        | 0                  | 0         | 0              | 0               | 0            |
| TULIP       | EWA EIB        | 0   | 0    | 0       | 0       | 0             | 0        | 0        | 0                  | 0         | 0              | 0               | 0            |
| JASMIN      | WE0 IE1        | 0   | 0    | 0       | 0       | 0             | 0        | 0        | 0                  | 0         | 0              | 0               | 0            |
| JASMIN      | EIA EIA        | 0   | 0    | 0       | 0       | 0             | 0        | 0        | 0                  | 0         | 0              | 0               | 0            |
| JASMIN      | EIA EIB        | 0   | 0    | 0       | 0       | 0             | 0        | 0        | 0                  | 0         | 0              | 0               | 0            |
| JASMIN      | EWA EIB        | 0   | 0    | 0       | 0       | 0             | 0        | 0        | 0                  | 0         | 0              | 0               | 0            |
| JASMIN      | EWA EIA        | 0   | 0    | 0       | 0       | 0             | 0        | 0        | 0                  | 0         | 0              | 0               | 0            |
| MADDY       | EWA EIA        | 0   | 0    | 0       | 0       | 0             | 0        | 0        | 0                  | 0         | 0              | 0               | 0            |
| MADDY       | EIA EWA        | 0   | 0    | 0       | 0       | 0             | 0        | 0        | 0                  | 0         | 0              | 0               | 0            |
| MADDY       | LCL LCL        | 0   | 0    | 0       | 0       | 0             | 0        | 0        | 0                  | 0         | 0              | 3               | 0            |

## SCACP SHOW CHANNEL

Table 6–2 describes the channel error data.

**Table 6–2 Channel Error Data**

| <b>Data</b>           | <b>Description</b>  |
|-----------------------|---|
| Seq Retransmit        | Number of times a sequenced VC packet sent on this channel was retransmitted, and the channel was penalized for the lost packet.<br>Note that the sequential retransmit is not necessarily a reflection of lost packet. It is possible that there can be a PE which could have triggered a retransmitted and results in a duplicate packet to be sent. This is reflected in the number of duplicate packets received in the remote node. The XMIT:REXMT ratio is also a measure of for how many transmitted packet, a packet was retransmitted. A very low value (less than 1000) reflects a possible network congestion. |
| LAN Transmit Failures | Number of times the local LAN device reported a failure to transmit a packet, and channel was penalized for the lost packet.  |
| Restart Channel       | Close or restart because channel control packet received indicating that the other end closed the channel and is restarting the channel handshake.  |
| Channel Init Timeouts | Channel initialization handshake timeout.   |
| Listen Timeouts       | No packets of any kind, including HELLOs, were received in LISTEN_TIMEOUT seconds.  |
| Bad Authorization Msg | Received a Channel Control (CC) packet with a bad authorization field.  |
| Bad ECO CC Msg        | Received a CC packet with an incompatible NISCA protocol ECO rev. field value.  |
| Bad Multicast Msg     | Received a bad multicast CC packet.   |
| CC Short Packet       | Received a CC packet that was short.  |
| CC Incompatible       | Received a CC packet that was incompatible with existing channels for this virtual circuit.   |
| Rev Old Channel       | Received a packet from an old instance of a channel.  |
| No MSCP Server        | No MSCP server available to respond to a received channel control solicit service packet asking this node to boot serve another node.   |
| Disk Not Served       | Disk is not served by this system.  |
| Buffer Size Change    | Change in buffer size.  |

5. SCACP> SHOW CHANNEL/ECS

The following is a snapshot of the output for SHOW CHANNEL/ECS command.

**Figure 6–2 Sample SHOW CHANNEL/ECS output**

\$MC SCACP SHOW CHANNEL/ECS

MADDY PEA0 Channel Summary 15-FEB-2009 11:44:02.02:

| Remote Node | Device Loc | Channel Rmt State | Total Errors | ECS State | Priority Cur Mgt | Hops | Buffer Size | Delay (uSec) | Load Class | Total Pkts(S+R) | CH Opened | Most Recent Time   | CH Closed Time |
|-------------|------------|-------------------|--------------|-----------|------------------|------|-------------|--------------|------------|-----------------|-----------|--------------------|----------------|
| ORCHID      | WE0        | IE0               | Open         | 38        | Y(T,P,F)         | 0 0  | 2           | 1394         | 3945.8     | 100             | 470836    | 14-FEB 11:35:11.54 | (No time)      |
| TULIP       | EIA        | EIA               | Open         | 1         | Y(T,P,F)         | 0 0  | 2           | 1426         | 503.4      | 100             | 269393    | 14-FEB 11:34:46.92 | (No time)      |
| TULIP       | EIA        | EIB               | Open         | 1         | Y(T,P,F)         | 0 0  | 2           | 1426         | 459.5      | 100             | 213800    | 14-FEB 11:34:45.04 | (No time)      |
| TULIP       | EWA        | EIA               | Open         | 0         | Y(T,P,F)         | 0 0  | 2           | 1426         | 574.3      | 1000            | 284950    | 14-FEB 11:34:38.06 | (No time)      |
| TULIP       | EWA        | EIB               | Open         | 1         | Y(T,P,F)         | 0 0  | 2           | 1426         | 477.7      | 1000            | 245966    | 14-FEB 11:34:38.06 | (No time)      |
| JASMIN      | EIA        | EIA               | Open         | 1         | Y(T,P,F)         | 0 0  | 2           | 1426         | 446.9      | 100             | 227512    | 14-FEB 11:34:46.04 | (No time)      |
| JASMIN      | EIA        | EIB               | Open         | 1         | Y(T,P,F)         | 0 0  | 2           | 1426         | 428.6      | 100             | 181574    | 14-FEB 11:34:45.04 | (No time)      |
| JASMIN      | EWA        | EIB               | Open         | 1         | Y(T,P,F)         | 0 0  | 2           | 1426         | 490.5      | 100             | 219178    | 14-FEB 11:34:39.25 | (No time)      |
| JASMIN      | EWA        | EIA               | Open         | 1         | Y(T,P,F)         | 0 0  | 2           | 1426         | 458.4      | 100             | 209228    | 14-FEB 11:34:38.84 | (No time)      |
| MADDY       | EWA        | EIA               | Open         | 1         | Y(T,P,F)         | 0 0  | 2           | 1426         | 250.0      | 100             | 153948    | 14-FEB 11:34:45.04 | (No time)      |
| MADDY       | EIA        | EWA               | Open         | 1         | Y(T,P,F)         | 0 0  | 2           | 1426         | 250.0      | 100             | 153626    | 14-FEB 11:34:45.04 | (No time)      |
| MADDY       | LCL        | LCL               | Open         | 3         | Y(T,P,F)         | 0 0  | 2           | 1426         | 246.9      | 0               | 153257    | 14-FEB 11:34:38.62 | (No time)      |

*ECS State Channel ECS Membership Information*

OpenVMS uses multiple interfaces to communicate with any other node in order to do load balancing of communication. However, at a given time not all interfaces that link the remote node are used to transmit datagrams. OpenVMS maintains a set of equivalent channels ECS (Equivalent Channel Set) within a VC. These channels have approximately equivalent transmission quality at a given time. Only the channels within the ECS are used to transmit datagrams to the given node. "A" is the generic format above may be "Y" (Yes) or "N" (No) stating whether the channel is in the ECS or not. The remaining characters specify the quality of the channel as they are derived from the channel performance data. The characters are:

- A: T or L for Tight or Lossy
- B: P, S, I, U for Peer, Superior, Inferior or Ungraded
- C: F or S for Fast or Slow

For more details about ECS, see the section *NISCA Transport Protocol Channel Selection and Congestion Control* in the *HP OpenVMS Cluster Systems manual*.

**Note**

From OpenVMS Version 8.3 onwards, Topology change column from SHOW CHANNEL/FULL or /5 has been removed. This is because you must not consider this as an 'error' instead it is the count of failovers from one interconnect to the other interconnect. Whenever failover occurs to another interconnect the buffer size changes. Hence this topology change is counted under "Buffer SizeDecr" column in SHOW VC/FULL output.

You can view the IP channel data summary by using the /IPCHANNEL qualifier, for example:

```
$ SHOW CHANNEL <nodename>/IPCHANNEL
```

# SCACP

## SHOW CHANNEL

Figure 6-3 Sample SHOW CHANNEL/IP output

```
MADDY$SHOW CHANNEL/IP

MADDY PEA0 Channel Summary 15-FEB-2009 11:44:56.92:

Remote  IP  Dev Channel Total   ECS   Priority   Buffer  Delay  Load  Total
Node   Loc Rmt State Errors State  Cur  Mgt  Hops  Size  (uSec) Class Pkts(S+R)  CH Opened Time  CH Closed Time
-----
ORCHID WEO IE0 Open    38 Y(T,P,F) 0  0  2  1394 4975.0 100  521626 14-FEB 11:35:11.54 (No time)
TULIP  WEO IE0 Open    1 N(T,I,F) 0  0  2  1394 250.0  100  192922 14-FEB 11:35:12.05 (No time)
JASMIN WEO IE1 Open    1 N(T,I,F) 0  0  2  1394 250.0  100  152181 14-FEB 11:35:12.10 (No time)
```

You can view the LAN channel data summary by using the /LANCHANNEL qualifier, for example:

```
$ SHOW CHANNEL/LANCHANNEL
```

Figure 6-4 Sample SHOW CHANNEL/LANCHANNEL output

```
$MC SCACP SHOW CHANNEL/LAN

MADDY PEA0 Channel Summary 15-FEB-2009 11:37:07.13:

Remote  LAN Dev Channe Total   ECS   Priority   Buffer  Delay  Load  Total
Node   Loc Rmt State Errors State  Cur  Mgt  Hops  Size  (uSec) Class Pkts(S+R)  CH Opened Time  CH Closed Time
-----
TULIP  EIA EIA Open    1 Y(T,P,F) 0  0  2  1426 2631.3 100  201210 14-FEB 11:34:46.92 (No time)
TULIP  EIA EIB Open    1 Y(T,P,F) 0  0  2  1426 2880.1 100  178304 14-FEB 11:34:45.04 (No time)
TULIP  EWA EIA Open    0 Y(T,P,F) 0  0  2  1426 2818.4 1000 189590 14-FEB 11:34:38.06 (No time)
TULIP  EWA EIB Open    1 N(T,P,S) 0  0  2  1426 3146.7 1000 209654 14-FEB 11:34:38.06 (No time)
JASMIN EIA EIA Open    1 Y(T,P,F) 0  0  2  1426 4454.9 100  157760 14-FEB 11:34:46.04 (No time)
JASMIN EIA EIB Open    1 Y(T,P,F) 0  0  2  1426 4332.5 100  157196 14-FEB 11:34:45.04 (No time)
JASMIN EWA EIB Open    1 Y(T,P,F) 0  0  2  1426 4682.1 100  158289 14-FEB 11:34:39.25 (No time)
JASMIN EWA EIA Open    1 Y(T,P,F) 0  0  2  1426 4967.5 100  159365 14-FEB 11:34:38.84 (No time)
MADDY  EWA EIA Open    1 Y(T,P,F) 0  0  2  1426 250.0  100  153210 14-FEB 11:34:45.04 (No time)
MADDY  EIA EWA Open    1 Y(T,P,F) 0  0  2  1426 250.0  100  152894 14-FEB 11:34:45.04 (No time)
MADDY  LCL LCL Open    3 Y(T,P,F) 0  0  2  1426 246.9  0  152524 14-FEB 11:34:38.62 (No time)
```

## SHOW CIRCUIT

Displays SCA circuit information. You can further qualify each node name you specify with additional parameters to uniquely identify a single circuit.

### Format

SHOW CIRCUIT `nodename`

#### Parameter

**nodename[,...]**

Includes specific circuits to individual nodes, which you can use wildcards to specify.

#### Qualifiers

**/EXCLUDE=(nodename[/PORT=portname[/RSTATION=n]][,...])**

Allows you to exclude a specific circuit to a node. If multiple circuits to the same node exist, you can use the /PORT and /RSTATION qualifiers to uniquely identify the circuit.

**/PORT=portname[/RSTATION=n]**

If multiple circuits to the same node exist, you can use the /PORT and /RSTATION qualifiers to uniquely identify the circuit. You can use the /RSTATION qualifier only in conjunction with the /PORT qualifier.

#### Example

SCACP>SHOW CIRCUIT

The command in this example displays all circuits to nodes over port PEA0.

Circuit data for CLUI02 at 07-DEC 11:55:31.80

| Node Name | Port Name | Priority Cur | Priority Mgt | Load Class | State | Remote Station | Remote Type |
|-----------|-----------|--------------|--------------|------------|-------|----------------|-------------|
| LYNX03    | PEA0      | 0            | 0            | 10         | Open  | dc             | NI          |
| CLUI01    | PEA0      | 0            | 0            | 10         | Open  | dd             | NI          |
| PRMMC2    | PEA0      | 0            | 0            | 10         | Open  | de             | NI          |
| RXBOT1    | PIB0      | 5            | 0            | 48         | Open  | 4              | RF72        |
| RXTOP1    | PIB0      | 5            | 0            | 48         | Open  | 1              | RF73        |
| RXTOP0    | PIB0      | 5            | 0            | 48         | Open  | 0              | RF73        |
| CLUI01    | PIB0      | 5            | 0            | 48         | Open  | 7              | N710        |
| R4JC3I    | PIC0      | 5            | 0            | 48         | Open  | 7              | RF73        |
| R4HLEK    | PIC0      | 5            | 0            | 48         | Open  | 5              | RF73        |
| R4XEWB    | PIC0      | 5            | 0            | 48         | Open  | 3              | RF73        |
| R4A1FN    | PIC0      | 5            | 0            | 48         | Open  | 2              | RF73        |
| R4XSVE    | PIC0      | 5            | 0            | 48         | Open  | 4              | RF73        |
| R4VLNI    | PIC0      | 5            | 0            | 48         | Open  | 1              | RF73        |

# SCACP SHOW CIRCUIT

SCACP>SHOW CIRCUIT\* /PORT=PEA0

This SHOW CIRCUIT command displays all circuits to all nodes.

Circuit data for CLUI02 at 07-DEC 12:42:23.03

| Node<br>Name | Port<br>Name | State | Priority<br>Cur Mgt | Load<br>Class | Remote_Port<br>Number | Type |
|--------------|--------------|-------|---------------------|---------------|-----------------------|------|
| LYNX03       | PEA0         | Open  | 0 0                 | 100           | dc                    | NI   |
| CLUI01       | PEA0         | Open  | 0 0                 | 10            | dd                    | NI   |
| PRMMC2       | PEA0         | Open  | 0 0                 | 10            | de                    | NI   |



---

## SHOW IP\_INTERFACE

Displays the PEdriver device IP interface data. Each device is an IP interface on the system, which can be used for NISCA communications.

### Format

SHOW IP\_INTERFACE ipinterface

#### Parameter

**ipinterfacename[,...]**

Includes one of more specific IP interface which you can use wildcards to specify.

- Use the /EXCLUDE qualifier to exclude IP interfaces.
- Use the SHOW IP\_INTERFACE command to display device names.

#### Qualifiers

**/ALL**

Includes all IP interface data.

**/COUNTERS**

Includes device counter data maintained by PEdriver and counters.

**/EXCLUDE=(IP\_INTERFACES[,...])**

Excludes specific IP devices, which you can use wildcards to specify.

**/INTERVAL**

For the /COUNTERS display, displays the changes to counters since the last SHOW command.

**/n**

Displays the nth page. To select a particular page of a multipage display, specify the number of the page you want to display.

**/OUTPUT=filespec**

Creates the specified file and directs output to it.

**/SDA**

Includes IP interface data displayed in the SDA format with all the data collected in one display for an IP interface.

**/SUMMARY**

Includes IP interface summary data. This is the default if /ALL, /COUNTERS, and /SDA qualifiers are not specified.

#### Example

```
SCACP>SHOW IP_INTERFACE/ALL
```

The following is a snapshot of the output for SHOW IP\_INTERFACE/ALL command.

# SCACP

## SHOW IP\_INTERFACE

Figure 6–5 Sample SHOW IP\_INTERFACE/ALL output

```

$MC SCACP SHOW IP_INTERFACE/ALL
MADDY PEA0 Device Summary 15-FEB-2009 11:43:35.00:
-----
Device  Device  Errors +  Status  Mgt  Buffer  MgtMax  Line  Total  Current
Type    Events  Status  Priority Size  BufSiz  Speed  Pkts(S+R)  IP  Address
-----
WE0     0      Run Online xChain_Disabled  0  1394  0  N/A  945220  15.146.235.10

MADDY PEA0 Device Counters and Errors 15-FEB-2009 11:43:35.00:
-----
Device  Messages  Transmit  Errors  Messages  Receive  Errors  Port  Port  Addr  Restart
Type    Messages  Bytes    Errors  Messages  Bytes    Errors  Usable Down Change Failed  *Last Event Time
-----
WE0     541783    72155739  0      403437    93906139  0      1     0     0     0     0     15-FEB 11:43:34.99

MADDY PEA0 Device Errors 15-FEB-2009 11:43:35.00:
-----
Device  -- Transmit --  Received  Allocation
Generic  Hello  Last Transmit Error  with Bad  Mcast TR  Short  Short  On Wrong  Discard  Failures On
Errors  Errors  (No time)  SYSTEMID  Message  CC Msg  DX Msg  Port  PortDisa  CH  VC
-----
WE0     0      0      (No time)  0      0      0      0      0      0      0      0

```

SCACP>SHOW IP\_INTERFACE/COUNTERS

Displays IP interface counters.

Table 6–3 describes the IP/LAN device error data.

Table 6–3 IP or LAN Device Error Data

| Data                         | Description   |
|------------------------------|---|
| Bad SCSSYSTEM ID             | Received a packet with the wrong SCSSYSTEM ID in it.  |
| MC Msgs Directed to TR Layer | Number of multicast packets directed to the NISCA Transport layer.  |
| Short CC Messages Received   | Number of packets received were short to contain a NISCA channel control header.  |
| Short DX Messages Received   | Number of packets received were short to contain a NISCA DX header for a LAN device.  |
| CH Allocation Failures       | Number of times the system failed to allocate memory for use as a channel structure in response to a packet received by this LAN device.  |
| VC Allocation Failures       | Number of times the system failed to allocate memory for use as a VC structure in response to a packet received by this LAN or IP device. |
| Wrong Port                   | Number of packets addressed to the wrong NISCA address (Invalid cluster group number).  |
| Port Disabled                | Number of packets discarded because the LAN or IP device was disabled.  |
| H/W Transmit Errors          | Number of local hardware transmit errors.   |
| Hello Transmit Errors        | Number of transmit errors during HELLOs.  |
| Last Transmit Error Reason   | Reason for last transmit error.   |
| Time of Last Transmit Error  | Time of last transmit error:date and time.  |

## SCACP SHOW IP\_INTERFACE

For IP interfaces, the error count can increase for the following reasons. These errors will be displayed with any of the error codes.

- The interface is unable to send data (SS\$\_SUSPENDED)
- Link is disconnected (SS\$\_LINKDISCON)

## SCACP SHOW LAN\_DEVICE

---

### SHOW LAN\_DEVICE

Displays PEdriver device data. Each device is a local LAN device on the system, which can be used for NISCA communications.

#### Format

```
SHOW LAN_DEVICE landevicename
```

#### Parameter

##### **landevicename[,...]**

Includes specific LAN devices, which you can use wildcards to specify.

Use the /EXCLUDE qualifier to exclude LAN devices.

Use the SHOW LAN\_DEVICE command to display device names.

#### Qualifiers

##### **/ALL**

Includes all device data.

##### **/COUNTERS**

Includes device counters data maintained by PEdriver and counters data maintained by the LAN drivers.

##### **/EXCLUDE=(landevicename[,...])**

Excludes specific LAN devices, which you can use wildcards to specify.

##### **/INTERVAL**

For the /COUNTERS display, displays the changes to counters since the last SHOW command.

##### **/n**

Displays the *n*th page. To select a particular page of a multipage display, specify the number of the page you want to display.

##### **/OUTPUT=filespec**

Creates the specified file and directs output to it.

##### **/SDA**

Includes LAN device data displayed in SDA format, with all the data collected in one display for one LAN device.

##### **/SUMMARY**

Includes device summary data. This is the default if /ALL, /COUNTERS, and /SDA qualifiers are not specified.

#### Example

```
SCACP> SHOW LAN_DEVICE/COUNTERS
```

The command in this example displays device counters.

```
SCACP> SHOW LAN_DEVICE/COUNTERS/INTERVAL
SCACP> SPAWN WAIT 0:0:10
SCACP> SHOW LAN_DEVICE/COUNTERS/INTERVAL
```

The first command in this example displays device counters since the last SHOW command. The SPAWN command tells the DCL WAIT command to insert a 10-

second delay. The second SHOW command displays counters after the 10-second period.

SCACP> SHOW LAN\_DEVICE/COUNTERS

The following is a snapshot of the output for SHOW LAN/ALL command.

Figure 6-6 Sample SHOW LAN/ALL output

```
SMC SCACP SHOW LAN/ALL
MADDY PEA0 Device Summary 15-FEB-2009 11:43:12.89:
-----
Device  Device  Errors +  Status          Mgt  Buffer  MgtMax  Line  Total  Current
Type    Events   Status      Priority Size  BufSiz  Speed Pkts(S+R) LAN Address
-----
LCL          0  Run Online Local Restart      0  1426    0  N/A    190438  00-00-00-00-00-00
EWA          0  Run Online Restart              0  1426    0  100    1114327  00-30-6E-4A-02-F9
EIA  82559    0  Run Online Restart              0  1426    0  100    1041011  00-30-6E-4A-13-3F

MADDY PEA0 Device Counters and Errors 15-FEB-2009 11:43:12.89:
-----
Device  Messages  Transmit  Errors  Receive  Errors  Port  Port  Addr  Restart  *Last Event Time
Type    Messages  Bytes    Errors  Messages Bytes    Usable Down Change Failed
-----
LCL    95219    12379748  0       95219   11237120  0     1*   0     0     0     14-FEB 11:34:31.70
EWA    455231   60696590  0       659096  167022916  0     1*   0     0     0     14-FEB 11:34:33.33
EIA    434778   57416246  0       606233  143615214  0     1*   0     0     0     14-FEB 11:34:41.63

MADDY PEA0 Device Errors 15-FEB-2009 11:43:12.89:
-----
Device  -- Transmit --  Hello  Last Transmit  Error  with Bad  Mcast TR  Received  Short  Short  On wrong  Discard  Allocation
Generic Errors  Errors  Error  SYSTEMID  Message  CC  Msg  DX  Msg  Port  PortDisa  Failures On
-----
LCL    0             0 (No time)  0       0       0       0       0       0       0       0       0       0
EWA    0             0 (No time)  0       0       0       0       0       0       0       0       0       0
EIA    0             0 (No time)  0       0       0       0       0       0       0       0       0       0

MADDY LAN Counters and Errors 15-FEB-2009 11:43:12.89:
-----
Device  Packets  Transmit  Errors  Packets  Receive  Errors  Buffer  Unavailable  -- Unrecognized --
Type    Packets  Bytes    Errors  Packets  Bytes    Errors  System  User  Individual Multicast  Events
-----
LCL    0             0       0       0       0       0       0       0       0       0       0
EWA   1734864    310115839  0     2442265  480199487  0       0       0       90  377506  0
EIA   435056     65710688  0     903433  175593881  0       0       0       0  297200  0
```

For list of all LAN errors, see Table 6-3.

# SCACP SHOW PORT

---

## SHOW PORT

Displays information about selected SCA ports.

### Format

SHOW PORT portname

#### Parameter

##### portname[,...]

Displays information about specific SCA ports, which you can use wildcards to specify. If no portname is specified, all ports on the node are displayed.

#### Qualifiers

##### /EXCLUDE=(portname[,...])

Excludes specific port names from the display. You cannot use wildcards to specify port names.

##### /OUTPUT=filespec

Creates the specified file and directs the output of the command to this file.

### Example

SCACP> SHOW PORT

The command in this example produces output similar to the following:

```
Port data for CLUI02 at 06-DEC 15:01:25.82
```

| Port<br>Name | Mgt<br>Prio | Msgs<br>Sent | Msgs<br>Rcvd | Dgrams<br>Sent | Dgrams<br>Rcvd |
|--------------|-------------|--------------|--------------|----------------|----------------|
| PEA0         | 0           | 64582        | 92237        | 0              | 0              |
| PIB0         | 0           | 95276        | 148937       | 0              | 0              |
| PIA0         | 0           | 0            | 0            | 0              | 0              |
| PIC0         | 0           | 62030        | 115148       | 0              | 0              |

---

## SHOW TRACE

Displays PEdriver tracing data and parameters.

---

### Note

---

This command is reserved for use by HP Services and OpenVMS Engineering only. Trace commands and output are subject to change from release to release.

---

## Format

SHOW TRACE nodename

### Parameter

#### **nodename[,...]**

Includes channels to specific nodes, which you can use wildcards to specify.

Each node name can be accompanied by optional qualifiers to specify local and remote device names. If no local or remote device name is specified, all channels associated with the specified node are included.

Use the SHOW CHANNEL command to display node names and local and remote device names.

### Qualifiers

#### **/CONTEXT**

Displays only PEdriver trace settings and the event definition. If this qualifier is not included, trace event data is displayed.

#### **/EVENT=(event1[,...])**

Enables tracing on specific events, which you can use wildcards to specify. The default is all of the events that are in the trace buffer.

Use the SHOW TRACE/CONTEXT command to display event names.

#### **/EXCLUDE[=(nodename[,...])**

Excludes channels to specific nodes, which you can use wildcards to specify. Each node name can be accompanied by optional qualifiers to specify local and remote device names.

If no local or remote device name is specified, all channels associated with the specified node are included.

#### **/GLOBAL (default when no nodes are specified)**

#### **/NOGLOBAL (default when nodes are specified)**

Specifies whether or not global trace data is to be returned.

#### **/INPUT=filename**

Reads trace data from the specified file and displays it.

#### **/LOCAL\_DEVICE=(landevicename[,...])**

Includes specific LAN devices that identify the local end of the channel. You can use wildcards to specify LAN devices.

Use the SHOW LAN\_DEVICE command to display device names.

## SCACP SHOW TRACE

### **/OUTPUT=filename**

Creates the specified file and directs output to it. If the filename extension is .DMP, the trace data is written to a dump file so that you can use the /INPUT qualifier to display it later.

### **/REMOTE\_DEVICE=(landvicename[,...])**

Includes specific LAN devices which identify the remote end of the channel, which you can use wildcards to specify.

Use the SHOW LAN\_DEVICE command to display device names.

### **/SORT**

#### **/NOSORT (default)**

Returns trace data sorted across channels, VCs, and the global trace buffer by sequence number. The default is trace data returned for channels and VCs one at a time, in order, for the channel or VC, but not across channels and VCs.

### **Examples**

1. SCACP> SHOW TRACE/CONTEXT

The command in this example displays trace settings and definition.

2. SCACP> SHOW TRACE/OUTPUT=NODE10.TRC

The command in this example displays trace data and writes it to the specified file.

An example of the screen output of a SHOW TRACE/CONTEXT command follows.

```
SYS999 Trace Context 31-JAN-2001 10:59:28.25:
  Trace buffer size requested 2048 bytes
  Trace buffer total allocated 92160 bytes
  Trace buffer allocations 45 successful
  Trace buffer allocations 0 failed
  Current trace sequence number 812286047
  System cycle counter 404196 cps
  Stop tracing 0 events after stop event
```



**SCACP  
SHOW TRACE**

| Trace  | Stop  | Default | Event       |
|--------|-------|---------|-------------|
| -----  | ----- | -----   | -----       |
| Active |       | Y       | Error       |
| Active |       |         | Penalize_ch |
| Active |       |         | Timer       |
| Active |       |         | Listen_timr |
| Active |       |         | Handsh_timr |
| Active |       |         | Size_probe  |
| Active |       |         | Delay_msmt  |
| Active |       |         | Verf_vack   |
| Active |       | Y       | CC_event    |
| Active |       | Y       | CC_state    |
| Active |       | Y       | Path_state  |
| Active |       | Y       | ECS_state   |
| Active |       |         | ACK_process |
| Active |       | Y       | Chan_update |
| Active |       |         | Rcvd_CC_msg |
| Active |       |         | Rcvd_TR_msg |
| Active |       |         | Send_TR_msg |
| Active |       |         | Xmt_failed  |
| Active |       | Y       | VC_state    |
| Active |       |         | ACK_timeout |
| Active |       | Y       | TMO_listen  |
|        |       | Y       | No_path     |

Channel Selection:

| Local Dev                     | Remote Dev | Remote Node Name | Selection |
|-------------------------------|------------|------------------|-----------|
| -----                         | -----      | -----            | -----     |
| All channels and VCs selected |            |                  |           |

## SCACP SHOW VC

---

### SHOW VC

Displays PEdriver virtual circuit data. Each VC is an SCACP communications path between the local system and a remote system comprised of a set of channels.

Use the SHOW CHANNEL or SHOW VC commands to display node names, which are simply the names of the remote nodes.

### Format

SHOW VC nodename

#### Parameter

**nodename[,...]**

Includes specific nodes, which you can use wildcards to specify.

#### Qualifiers

**/ALL**

Includes all VC data.

**/COUNTERS**

Includes VC counter data.

**/EXCLUDE=(nodename[,...])**

Excludes specific nodes, which you can use wildcards to specify.

Use the SHOW CHANNEL or SHOW VC commands to display VC names, which are simply the names of the remote nodes.

**/INTERVAL**

For the /COUNTERS display, displays the changes to counters since the last SHOW command.

**/n**

Displays the *n*th page. To select a particular page of a multipage display, specify the number of the page you want to display.

**/OUTPUT=filespec**

Creates the specified file and directs output to it.

**/SDA**

Includes VC data displayed in SDA format.

**/SUMMARY**

Includes VC summary data. This is the default if /ALL, /COUNTERS, and /SDA qualifiers are not specified.

#### Examples

1. SCACP> SHOW VC/COUNTERS NODE10

The command in this example displays VC counters for all VCs whose name (that is, remote node name) starts with NODE10.

```
2. SCACP> SHOW VC/COUNTERS/INTERVAL
   SCACP> SPAWN WAIT 0:0:10
   SCACP> SHOW VC/COUNTERS/INTERVAL
```

The first command in this example displays VC counters since the last SHOW command. The SPAWN command tells the DCL WAIT command to insert a 10-second delay. The second SHOW VC command displays counters after the 10-second period.

## **SPAWN**

Creates a subprocess of the current process. The SPAWN command copies the context of the subprocess from the current process.

### **Format**

SPAWN [command-string]

#### **Parameter**

##### **command-string**

A string of commands to be executed in the context of the created subprocess. After the command string is executed, control returns to SCACP.

#### **Qualifiers**

None.

#### **Example**

```
SCACP> SPAWN SHOW TIME
24-AUG-2005 15:22:39
SCACP>
```

The command in this example creates a subprocess of the current process and displays the time.

## START IP\_INTERFACE

Directs PEdriver to start using the specified IP interface.

### Format

```
START IP_INTERFACE ipinterface
```

#### Parameter

##### **ipinterface[,...]**

Includes specific IP interfaces, which you can use wildcards to specify.

- Use the /EXCLUDE qualifier to exclude IP interfaces.
- Use the SHOW IP\_INTERFACE command to display IP interfaces.

#### Qualifiers

##### **/EXCLUDE=(ipinterface[,...])**

Excludes specific IP interface, which you can use wildcards to specify. Use the SHOW IP\_INTERFACE command to display IP interface names.

#### Example

```
SCACP> START IP_INTERFACE WE0
```

This command starts PEdriver on the IP interface WE0.

## SCACP START LAN\_DEVICE

---

### START LAN\_DEVICE

Directs PEdriver to start using the specified LAN device. The original (and still supported) way to start PEdriver on a LAN device is `SYS$EXAMPLES:LAVC$START_BUS`.

#### Format

```
START LAN_DEVICE landevicename
```

##### Parameter

###### **landevicename[...]**

Includes specific LAN devices, which you can use wildcards to specify.

Use the `/EXCLUDE` qualifier to exclude LAN devices.

Use the `SHOW LAN_DEVICE` command to display device names.

##### Qualifiers

###### **/EXCLUDE=(landevicename[...])**

Excludes specific LAN devices, which you can use wildcards to specify.

Use the `SHOW LAN_DEVICE` command to display device names.

##### Example

```
SCACP> START LAN_DEVICE EWA
```

This command starts PEdriver on the LAN device EWA.

## START TRACE

Starts or resumes PEdriver tracing, optionally setting tracing options.

---

**Note**

---

This command is reserved for use by HP Services and OpenVMS Engineering only. Trace commands, their qualifiers, and output are subject to change from release to release.

---

### Format

START TRACE nodename

#### Parameter

##### **nodename[,...]**

Includes information about communications with specific nodes, which you can use wildcards to specify. Each node name can be accompanied by optional qualifiers to specify local and remote device names.

If no local or remote device name is specified, the VC and all channels associated with the specified node are included.

Use the SHOW CHANNEL command to display node names and local and remote device names.

#### Qualifiers

##### **/AFTER=n**

After the trace stop condition has been satisfied, continues tracing for *n* events, and then stops. If you do not specify /AFTER, tracing does not continue after the trace stop event. *n* can be any value between 0 and FFFFFFFF.

##### **/DEFAULT**

Sets the trace context back to the default settings, which are:

```
channelname=*
/AFTER=0
/EVENT=default settings
/STOP
/SIZE=512
```

##### **/EVENT=(event1[,...])**

Enables tracing on specific events, which you can use wildcards to specify. The default is a subset of the events, which includes most errors and state changes.

Use the SHOW TRACE/CONTEXT command to display event names.

##### **/EXCLUDE=(landevicename/IPinterface[,...])**

Excludes specific LAN devices/IP interfaces, which you can use wildcards to specify.

Use the SHOW LAN\_DEVICE/SHOW IP\_INTERFACE command to display device names.

##### **/LOCAL\_DEVICE=(landevicename/IPinterface[,...])**

Includes specific LAN devices that identify the local end of the channel. You can use wildcards to specify LAN devices/IP interfaces.

## SCACP START TRACE

Use the SHOW LAN\_DEVICE/SHOW IP\_INTERFACE command to display device names.

### **/REMOTE\_DEVICE=(landevicename/IPinterface[,...])**

Includes specific LAN devices that identify the remote end of the channel. You can use wildcards to specify LAN devices/IP interfaces.

Use the SHOW LAN\_DEVICE/SHOW IP\_INTERFACE command to display device names.

### **/STOP=(event[,...])**

Stops tracing on specific events, which you can use wildcards to specify. The default is to stop no events.

Use the SHOW TRACE/CONTEXT command to display event names.

### **/SIZE=n**

Specifies a trace buffer size of *n* bytes to be used by PEdriver for each trace buffer: one for global PEdriver use, one for each selected channel, and one for each selected VC. *n* can be any value between 0 and FFFFFFFF.

### **Examples**

1. SCACP> START TRACE/EVENT=CC\_STATE/SIZE=2000

The command in this example changes the Trace Channel Control layer state with a 2000-byte trace buffer.

2. SCACP> START TRACE/EVENT=ALL NODE10,NODE20

The command in this example traces all events but only for the NODE10 and NODE20 channels.



---

## STOP IP\_INTERFACE

Directs PEdriver to stop using the specified IP interface.

---

### Caution

---

If you use STOP IP\_INTERFACE to stop the only connection you have to a cluster, it results in a system CLUEXIT. If you use STOP IP\_INTERFACE to stop the only the connection, connected to a cluster, the system will CLUEXIT even when you have another connection that uses a different cluster port. However, if you stop all the IP\_INTERFACE results in excessive activity. When PEdriver loses access to all of its IP interfaces, it makes an effort to restore cluster IP communications by completely re-initializing itself. After the displayed retry count is exceeded, PEdriver permanently goes offline. To disable cluster use of all but one IP interface, enter the following command:

```
SCACP> STOP IP_INTERFACE * /EXCLUDE=ipinterface
```

All IP interfaces are stopped except the excluded interface and PEdriver does not need to be reset.

---

## Format

```
STOP IP_INTERFACE ipinterface[,...]
```

### Parameter

**ipinterface[,...]**

Includes specific IP interface, which you can use wildcards to specify.

- Use the /EXCLUDE qualifier to exclude IP interfaces.
- Use the SHOW IP\_INTERFACE command to display IP interface names.

### Qualifiers

**/EXCLUDE=(ipinterface[,...])**

Excludes specific IP interface, which you can use wildcards to specify.

### Example

```
SCACP> STOP IP_INTERFACE WE0
```

This command stops PEdriver on the IP interface WE0.

## SCACP STOP LAN\_DEVICE

---

### STOP LAN\_DEVICE

Directs PEdriver to stop using the specified LAN device. The original (and still supported) way to stop PEdriver on a LAN device is SYS\$EXAMPLES:LAVC\$STOP\_BUS.

---

#### Caution

---

If you use either STOP LAN\_DEVICE or SYS\$EXAMPLES:LAVC\$STOP\_BUS to stop the only connection you have to a cluster, you cause the system to CLUEXIT.

Even when you have another connection using a different cluster port, stopping all LAN devices results in excessive activity. When PEdriver loses access to all of its LAN devices, it makes an effort to restore cluster communications by completely re-initializing itself.

After the last LAN device is stopped, the reinitialization produces an error message similar to the following:

```
SCACP> STOP LAN *  
;%PEA0, Port is Reinitializing ( 49 Retries Left). Check the Error Log.
```

After the displayed retry count is exceeded, PEdriver permanently goes offline.

To disable cluster use of all but 1 LAN device, enter the following command:

```
SCACP> STOP LAN * /EXCLUDE=landevicename
```

All LAN devices except the excluded device are stopped, and PEdriver does not need to be reset.

---

### Format

```
STOP LAN_DEVICE landevicename
```

#### Parameter

##### landevicename[,...]

Includes specific LAN devices, which you can use wildcards to specify.

Use the /EXCLUDE qualifier to exclude LAN devices.

Use the SHOW LAN\_DEVICE command to display device names.

#### Qualifier

##### /EXCLUDE=(landevicename[,...])

Excludes specific LAN devices, which you can use wildcards to specify.

#### Example

```
SCACP> STOP LAN_DEVICE EWA
```

This command stops PEdriver on the LAN device EWA.

---

## **STOP TRACE**

Stops PEDRIVER tracing. You can read the trace data recorded so far with a SHOW TRACE command.

To revert trace behavior to initial settings, enter the command SET TRACE/DEFAULT.

---

### **Note**

---

This command is reserved for use by HP Services and OpenVMS Engineering only. Trace commands and output are subject to change from release to release.

---

## **Format**

STOP TRACE

### **Parameters**

None.

### **Qualifiers**

None.

### **Example**

```
SCACP> STOP TRACE
```

The command in this example stops PEDRIVER tracing.



---

## Show Cluster Utility

### 7.1 SHOW CLUSTER Description

The OpenVMS Show Cluster utility (SHOW CLUSTER) monitors nodes in an OpenVMS Cluster and displays information about cluster-specific activity and performance. SHOW CLUSTER collects information from the System Communications Services (SCS) database, the connection management database, and the port database.

Table 7–1 shows the classes of data output by SHOW CLUSTER.

**Table 7–1 Classes of SHOW CLUSTER Information**

| <b>Class</b> | <b>Description</b>   |
|--------------|--|
| CIRCUITS     | Describes information about the virtual circuits on a system, such as the local port name, the remote port type and number, the number of connections on the circuit, and the circuit state. |
| CLUSTER      | Displays general OpenVMS Cluster information, such as the time the cluster was formed, the last time a system joined or left the cluster, and the cluster quorum.                            |
| CONNECTIONS  | Describes connections established over a virtual circuit, such as the names of the local and remote processes, and the state of the connection.  |
| COUNTERS     | Displays accumulated statistics on connection traffic, such as the number of application datagrams, and the number of application messages that have been sent or received.                  |
| CREDITS      | Displays the send and receive credits for each connection.   |
| ERRORS       | Displays a count of errors that have occurred on each port, along with information related to reinitializing those ports.  |
| LOCAL_PORTS  | Describes the local system interface to the OpenVMS Cluster, such as the name, number, and status of each port, and the number of entries in the queues associated with each port.           |
| MEMBERS      | Contains node-specific information, such as each node's identification numbers, quorum status, and connection status.  |
| SYSTEMS      | Lists information about all systems in the OpenVMS Cluster, such as the node identification numbers, node names, hardware types, and software versions.                                      |

Each class contains a number of fields of data. Table 7–2 through Table 7–10 list the fields of data in each class.

# SHOW CLUSTER

## 7.1 SHOW CLUSTER Description

**Table 7-2 CIRCUITS Class Fields**

| Field Name      | Description  |
|-----------------|--|
| CABLE_STATUS    | Status of the CI circuit paths A and B. Crossed cables are also noted. The field applies only to the CI. Possible displays are as follows:<br>- Paths A and B are bad.<br>A- Path A is good.<br>-B Path B is good.<br>A-B Paths A and B are good.<br>CROSSED Cables are crossed.   |
| CIR_STATE       | State of the virtual circuit. Possible displays are as follows:<br>CLOSED Circuit is closed.<br>OPEN Circuit is open.<br>ST_REC Circuit has a start received.<br>ST_SENT Circuit has a start sent.<br>VC_FAIL Virtual circuit failure is in progress.  |
| LD_CLASS        | The circuit's current capacity rating.   |
| LPORT_NAME      | Device name of the local port associated with the circuit (PAA0, PAB0, PEA0).  |
| MGT_PRIORITY    | Priority value assigned to the circuit by management action.   |
| NUM_CONNECTIONS | Number of connections on the circuit between the local and remote systems.   |
| PRIORITY        | Circuit's current priority, which is the sum of the management priorities assigned to the circuit and the associated local port.   |
| REM_STATE       | State of the remote port. Possible displays are as follows:<br>DISAB Remote port is disabled.<br>ENAB Remote port is enabled.<br>M_DISAB Remote port is in maintenance mode and is disabled.<br>M_ENAB Remote port is in maintenance mode and is enabled.<br>M_UNINIT Remote port is in maintenance mode and has not been initialized.<br>UNINIT Remote port has not been initialized. |
| RP_FUNCTIONS    | Function mask of the remote port.  |
| RPORT_NUM       | Port number of the remote port associated with the circuit. The field applies only to CI.  |
| RP_OWNER        | Port number of the remote port owner.  |
| RP_REVISION     | Hardware or microcode revision number of the remote port.  |

(continued on next page)

## SHOW CLUSTER

### 7.1 SHOW CLUSTER Description

**Table 7–2 (Cont.) CIRCUITS Class Fields**

| Field Name  | Description  |
|-------------|--|
| RP_TYPE     | Type of remote port associated with the circuit. Examples of some possible types might include: CIMNA, KFMSA, SHAC, SII, BVPSSP (a BVP storage systems port), CI780, CI750, CIBCA-A and CIBCA-B, RF and TF devices (for example RF73 or TF85), HSC devices (for example, HSC65 or HSC90), Ethernet, PASSTH (port is in passthrough mode), and so on. |
| SCS_WAITERS | Number of connections waiting to send SCS control messages on the virtual circuit.   |

**Table 7–3 CLUSTER Class Fields**

| Field Name        | Description   |
|-------------------|---|
| CL_EXPECTED_VOTES | The number of votes the cluster has ever seen – or could see, as determined by the connection manager. The value is based on the maximum value of CL_EXPECTED_VOTES, the value for EXPECTED_VOTES that is specified by each node, and the sum of the cluster votes (CL_VOTES). CL_QUORUM is derived from CL_EXPECTED_VOTES. |
| CL_MEMBERS        | Number of processors participating in the cluster.  |
| CL_QDVOTES        | Number of votes contributed by the quorum disk.   |
| CL_QUORUM         | The number of votes that must be present for the cluster to function and permit user activity. CL_QUORUM is equal to (CL_EXPECTED_VOTES + 2) divided by 2.  |
| CL_VOTES          | Total number of votes contributed by all members of the cluster at any point in time.   |
| FORMED            | Time at which the cluster was formed, expressed as dd-mmm-yy hh:mm.   |
| LAST_TRANSITION   | Last time at which a system left or joined the cluster, expressed as dd-mmm-yy hh:mm.   |
| MEMSEQ            | Membership state sequence number, which changes whenever a node joins or leaves the cluster.  |
| QD_NAME           | Full device name of the quorum disk.  |
| QF_VOTE           | Indicates whether or not the quorum disk is contributing any votes towards the cluster quorum.  |

## SHOW CLUSTER

### 7.1 SHOW CLUSTER Description

**Table 7–4 CONNECTIONS Class Fields**

| Field Name    | Description   |
|---------------|---|
| CON_STATE     | The state of the connection. Possible displays are as follows:<br>ACCP_SENT      Accept request has been sent.<br>CLOSED        Connection is closed.<br>CON_ACK        Connect request has been sent and acknowledged.<br>CON_REC        Connect request has been received.<br>CON_SENT       Connect request has been sent.<br>DISC_ACK      Disconnect request is acknowledged.<br>DISC_MTCH     Disconnect request is matched.<br>DISC_REC      Disconnect request has been received.<br>DISC_SENT     Disconnect request has been sent.<br>LISTEN        Connection is in the listen state.<br>OPEN           Connection is open.<br>REJ_SENT      Reject has been sent.<br>VC_FAIL        Virtual circuit has failed. |
| LOC_CONID     | Identification number of the local side of the connection.  |
| LOC_PROC_NAME | Name of the local process associated with the connection.   |
| REM_CONID     | Identification number of the remote side of the connection. This information does not apply for connections in the listen state.  |
| REM_PROC_NAME | Name of the remote process associated with the connection. This information does not apply for connections in the listen state.   |
| SCS_STATE     | SCS send blocked state. If the connection is waiting to send an SCS control block message, the SCS send blocked state indicates what kind of message it is waiting to send. Possible displays are as follows:<br>ACCP_PEND      Waiting to send an accept request.<br>CLEAR          Not blocked.<br>CON_PEND      Waiting to send a connection request.<br>CR_PEND        Waiting to send credit.<br>DCR_PEND      Waiting to send credit in preparation for a disconnect.<br>DISC_PEND     Waiting to send a disconnect request.<br>REJ_PEND      Waiting to send a reject request.   |



## SHOW CLUSTER 7.1 SHOW CLUSTER Description

**Table 7–5 COUNTERS Class Fields**

| Field Name | Description   |
|------------|---|
| BDT_WAITS  | Number of times this connection had to wait for a buffer descriptor.  |
| BLKS_REQ   | Number of block-request data commands initiated to block transfer data from the remote system to the local system.          |
| BLKS_SENT  | Number of block-send data commands initiated to block-transfer data from the local system to the remote system.             |
| CR_WAITS   | Number of times this connection had to wait for send credit.  |
| DGS_DSCRD  | Number of application datagrams discarded by the port driver.   |
| DGS_RCVD   | Number of application datagrams received by the local system over the connection from the remote system and given to SYSAP. |
| DGS_SENT   | Number of application datagrams sent over the connection.   |
| KB_MAPPED  | Number of kilobytes of data mapped for block transfer.  |
| KB_RCVD    | Number of kilobytes of data received by the local system from the remote system through request-data commands.              |
| KB_SENT    | Number of kilobytes of data sent from the local system to the remote system through send-data commands.                     |
| MSGS_RCVD  | Number of application datagram messages received over the connection.   |
| MSGS_SENT  | Number of application datagram messages sent over the connection.   |

**Table 7–6 CREDITS Class Fields**

| Field Name | Description  |
|------------|--|
| INIT_REC   | Initial receive credit extended to the remote system when the connection was made. |
| MIN_REC    | Minimum receive credit (minimum send credit required by the remote system).        |
| MIN_SEND   | Minimum send credit.   |
| PEND_REC   | Receive credit not yet extended to the remote system.                              |
| RECEIVE    | Receive credit (send credit held by the remote system).                            |
| SEND       | Current send credit.   |

**Table 7–7 ERRORS Class Fields**

| Field Name | Description   |
|------------|---|
| ERT_COUNT  | Number of port reinitialization attempts remaining.   |
| ERT_MAX    | Total number of times a recovery from fatal port errors can be attempted by shutting down all virtual circuits and connections and reinitializing the port. |

(continued on next page)

# SHOW CLUSTER

## 7.1 SHOW CLUSTER Description

**Table 7-7 (Cont.) ERRORS Class Fields**

| Field Name | Description   |
|------------|---|
| NUM_ERRORS | Number of errors that have been logged on the port since the system was booted. This number includes errors encountered in reinitialization attempts as well as recoverable errors, such as virtual circuit failure. This is the same error count as that displayed by the DCL command SHOW DEVICE. |

**Table 7-8 LOCAL\_PORTS Class Fields**

| Field Name    | Description   |
|---------------|---|
| BUFF_DESCR    | Number of buffer descriptors in use.  |
| CMDS_QUEUED   | Total number of messages, datagrams, and port commands queued for transmission at all priorities by the port.   |
| COUNTER_OWNER | Name of the process currently using the port traffic counters.  |
| DGI_MAP       | A 16-bit bit map displayed as four hexadecimal digits. Each bit in the map represents a port in the cluster from which datagram reception has been disabled.  |
| DG_OVRHD_SIZE | Number of bytes of port header, SCS header, and DECnet header in a datagram.  |
| DGS_FREE      | Number of free datagram buffers currently queued for receive commands.  |
| FORM_CIRCS    | Number of formative circuits (circuits in the process of opening) from the port.  |
| FREE_BUFF     | Number of CI buffer descriptors free for use.   |
| LB_STATUS     | Loopback status of each cable from the port to the star coupler. The field applies only to CI. Possible displays are as follows:<br>A-B      Loopback tests pass on paths A and B.<br>A-#      Loopback tests pass on path A.<br>#-B      Loopback tests pass on path B.<br>#-#      Loopback tests failed on paths A and B.<br>N/A      Loopback tests are not being done.   |
| LOG_MAP       | A 16-bit bit map displayed as four hexadecimal digits. Each bit in the map represents a port in the cluster for which an error was logged.<br><br>Errors are logged when data provided by the configuration database on the local system conflicts with data provided by the remote system. When a conflict is discovered and an error is logged, virtual circuits to the remote system can no longer be established. |
| LP_LD_CLASS   | Hard-coded capacity value of the port, based on the megabits/second rate of the interconnect of the port.   |
| LP_PRIORITY   | Management priority assigned to the port.   |
| LP_STATUS     | Status of the local port. The port is either on line or off line.   |
| LP_TYPE       | Device type of the port (CI780, CI750).   |

(continued on next page)

## SHOW CLUSTER 7.1 SHOW CLUSTER Description

**Table 7–8 (Cont.) LOCAL\_PORTS Class Fields**

| Field Name   | Description   |
|--------------|---|
| MAX_PORT     | Largest port number to which a virtual circuit open is attempted.   |
| MSG_FREE     | Number of free message buffers currently queued for receives commands.  |
| MSG_HDR_SIZE | Number of bytes of port header and SCS header in a message.   |
| NAME         | Device name of the local port.  |
| OPEN_CIRCS   | Number of virtual circuits open from the port.  |
| POOL_WAITERS | Number of processes waiting for nonpaged pool resources for message buffers.  |
| PORT_NUM     | Port number assigned to the port.   |
| PRT_MAP      | A 16-bit bit map displayed as three hexadecimal digits. Each bit in the map represents a port in the cluster that has been recognized by the host system. |
| RSPS_QUEUED  | Total number of responses of all kinds received from the port but not yet processed.  |

**Table 7–9 MEMBERS Class Fields**

| Field Name | Description   |        |                                 |        |                       |         |                                       |      |                            |            |                               |     |  |      |                     |          |  |           |  |      |                         |
|------------|---|--------|---------------------------------|--------|-----------------------|---------|---------------------------------------|------|----------------------------|------------|-------------------------------|-----|--|------|---------------------|----------|--|-----------|--|------|-------------------------|
| ACK_LM     | Maximum number of OpenVMS Cluster messages the remote system can receive before sending an acknowledgment.  |        |                                 |        |                       |         |                                       |      |                            |            |                               |     |  |      |                     |          |  |           |  |      |                         |
| ACKR_SQ    | Sequence number of the last acknowledgment received over the cluster connection.  |        |                                 |        |                       |         |                                       |      |                            |            |                               |     |  |      |                     |          |  |           |  |      |                         |
| CNX_STATE  | State of the cluster connection. Possible displays are as follows: <table style="margin-left: 20px; border: none;"> <tr> <td>ACCEPT</td> <td>Initial connection is accepted.</td> </tr> <tr> <td>CLOSED</td> <td>Connection is closed.</td> </tr> <tr> <td>CONNECT</td> <td>Initial connection is being accepted.</td> </tr> <tr> <td>DEAD</td> <td>No connection is possible.</td> </tr> <tr> <td>DISCONNECT</td> <td>Disconnection is in progress.</td> </tr> <tr> <td>NEW</td> <td>No attempt to make a connection has been made yet.</td> </tr> <tr> <td>OPEN</td> <td>Connection is open.</td> </tr> <tr> <td>REACCEPT</td> <td>Connection is accepting the reconnect request.</td> </tr> <tr> <td>RECONNECT</td> <td>Connection is attempting to reconnect.</td> </tr> <tr> <td>WAIT</td> <td>Timeout is in progress.</td> </tr> </table> | ACCEPT | Initial connection is accepted. | CLOSED | Connection is closed. | CONNECT | Initial connection is being accepted. | DEAD | No connection is possible. | DISCONNECT | Disconnection is in progress. | NEW | No attempt to make a connection has been made yet. | OPEN | Connection is open. | REACCEPT | Connection is accepting the reconnect request. | RECONNECT | Connection is attempting to reconnect. | WAIT | Timeout is in progress. |
| ACCEPT     | Initial connection is accepted.   |        |                                 |        |                       |         |                                       |      |                            |            |                               |     |  |      |                     |          |  |           |  |      |                         |
| CLOSED     | Connection is closed.   |        |                                 |        |                       |         |                                       |      |                            |            |                               |     |  |      |                     |          |  |           |  |      |                         |
| CONNECT    | Initial connection is being accepted.   |        |                                 |        |                       |         |                                       |      |                            |            |                               |     |  |      |                     |          |  |           |  |      |                         |
| DEAD       | No connection is possible.  |        |                                 |        |                       |         |                                       |      |                            |            |                               |     |  |      |                     |          |  |           |  |      |                         |
| DISCONNECT | Disconnection is in progress.   |        |                                 |        |                       |         |                                       |      |                            |            |                               |     |  |      |                     |          |  |           |  |      |                         |
| NEW        | No attempt to make a connection has been made yet.  |        |                                 |        |                       |         |                                       |      |                            |            |                               |     |  |      |                     |          |  |           |  |      |                         |
| OPEN       | Connection is open.   |        |                                 |        |                       |         |                                       |      |                            |            |                               |     |  |      |                     |          |  |           |  |      |                         |
| REACCEPT   | Connection is accepting the reconnect request.  |        |                                 |        |                       |         |                                       |      |                            |            |                               |     |  |      |                     |          |  |           |  |      |                         |
| RECONNECT  | Connection is attempting to reconnect.  |        |                                 |        |                       |         |                                       |      |                            |            |                               |     |  |      |                     |          |  |           |  |      |                         |
| WAIT       | Timeout is in progress.   |        |                                 |        |                       |         |                                       |      |                            |            |                               |     |  |      |                     |          |  |           |  |      |                         |
| CSID       | Cluster system identification number. This number is unique over the life of the cluster. Unlike SYS_ID, this identification number may change when the system reboots.   |        |                                 |        |                       |         |                                       |      |                            |            |                               |     |  |      |                     |          |  |           |  |      |                         |
| DIR_WT     | Lock manager distributed directory weight.  |        |                                 |        |                       |         |                                       |      |                            |            |                               |     |  |      |                     |          |  |           |  |      |                         |

(continued on next page)

# SHOW CLUSTER

## 7.1 SHOW CLUSTER Description

**Table 7–9 (Cont.) MEMBERS Class Fields**

| Field Name     | Description  |
|----------------|--|
| EXPECTED_VOTES | <p>Maximum number of votes that an individual node can encounter. Used as an initial estimate for computing CL_EXPECTED_VOTES.</p> <p>The cluster manager sets this number using the EXPECTED_VOTES system parameter. It is possible for this field to display a number smaller than the EXPECTED_VOTES parameter setting if the REMOVE_NODE option was used to shut down a cluster member or the SET CLUSTER/EXPECTED_VOTES DCL command was used since this node was last rebooted.</p> <p>The dynamic value for EXPECTED_VOTES used clusterwide is the CL_EXPECTED_VOTES field, which is described in Table 7–3.</p> |
| PROTOCOL       | Protocol version number and ECO level of the connection management software.   |
| QDVOTES        | Number of votes the remote system recommends be contributed by the quorum disk. Normally, the cluster manager sets this number using the system parameter QDSKVOTES.   |
| QF_ACTIVE      | Indicates whether the remote system's quorum file is accessible.   |
| QF_SAME        | Indicates whether the local and remote systems agree about which disk is the quorum disk.  |
| QF_WATCHER     | Remote system has an active connection to the quorum disk and can verify its connection for members unable to access the disk directly.  |
| QUORUM         | Derived from EXPECTED_VOTES and calculated by the connection manager. It represents an initial value for the minimum number of votes that must be present for this node to function. The dynamic QUORUM value is the CL_QUORUM field, which is described in the CLUSTER class category in Table 7–3.   |
| RCVD_SQ        | Sequence number of the last message received over the OpenVMS Cluster connection.  |
| RECNXINTERVAL  | Displays the time (in seconds) that the connection manager will wait before timing out the corresponding connection. It is the maximum of the value contained in the system parameter RECNXINTERVAL on the local node and the amount of time it would take for the connection manager on the remote node to discover that the connection is broken.  |
| SEND_SQ        | Sequence number of the next message to be sent over the OpenVMS Cluster connection.  |

(continued on next page)

## SHOW CLUSTER

### 7.1 SHOW CLUSTER Description

**Table 7–9 (Cont.) MEMBERS Class Fields**

| Field Name      | Description   |
|-----------------|---|
| STATUS          | Status of the node in the cluster. Possible displays are as follows:  |
| blank           | System is not being considered as a cluster member.   |
| BRK_MEM         | System is a member of the cluster, but the connection manager has lost communication with it.   |
| BRK_NEW         | System has just booted, but has not yet joined the cluster and the connection manager has lost communication with it.   |
| BRK_NON         | Connection manager has lost communication with the system and the system is no longer a member of the cluster.  |
| BRK_REM         | Connection manager has lost communication with the system, and the system has been removed from the cluster.  |
| MEMBER          | System is participating in the cluster.   |
| NEW             | System has just booted, but has not yet joined the cluster. If this system would normally be a member of the cluster and is displaying NEW in this field, you can expect that the display will eventually change to MEMBER. |
| NON             | System is not a member of the cluster.  |
| REMOVED         | System has been removed from the cluster.   |
| SW_VERS         | Indicator of the software version running on the node.  |
| TRANSITION_TIME | Time of the system's last change in membership status. (See the STATUS field.)  |
| UNACKED         | Number of unacknowledged OpenVMS Cluster messages received by the remote system.  |
| VOTES           | Number of votes the remote node contributes toward quorum. Normally, the cluster manager sets this number with the system parameter VOTES.  |
| WARMCDRPS       | Number of CDRPs on the CDRP free queue.   |

**Table 7–10 SYSTEMS Class Fields**

| Field Name | Description  |
|------------|--|
| DG_SIZE    | Maximum number of bytes of application data in datagrams sent over the circuit.  |
| HW_TYPE    | System hardware type (for example, VAXstation 3100 or HS70). (Enclose the system type between double quotation marks.) |
| HW_VERS    | Hardware configuration and revision levels of the remote system.   |

(continued on next page)

# SHOW CLUSTER

## 7.1 SHOW CLUSTER Description

**Table 7–10 (Cont.) SYSTEMS Class Fields**

| Field Name   | Description  |
|--------------|--|
| INCARNATION  | Unique 16-digit hexadecimal number established when the system is booted.  |
| MSG_SIZE     | Maximum number of bytes of application data in messages sent over the circuit.   |
| NODE         | Node name of the remote system. Normally, the cluster manager sets the node name using the system parameter SCSNODE. The node name should be the same as the DECnet node name. (Note that SCSNODE cannot be more than six characters.) |
| NUM_CIRCUITS | Number of virtual circuits between the local system and remote systems.  |
| SOFTWARE     | Name and version of the operating system currently running on the remote system.   |
| SYS_ID       | Identification number of the remote system. Normally, the cluster manager sets this number using the system parameters SCSSYSTEMID and SCSSYSTEMIDH. This number should be the same as the DECnet node number.                         |

You can customize the SHOW CLUSTER display to include the information most important to your needs by dynamically adding and removing classes and fields. For example, if you add a field that belongs to the CLUSTER class or the LOCAL\_PORTS class, SHOW CLUSTER adds the new column of information to the display.

By default, the SHOW CLUSTER display includes the NODE and SOFTWARE fields of the SYSTEMS class and the STATUS field of the MEMBERS class. Figure 7–1 presents a sample customized SHOW CLUSTER display in which the HW\_TYPE, VOTES, and TRANSITION\_TIME fields have been added to the default SHOW CLUSTER display.

**Figure 7–1 Sample SHOW CLUSTER Report**

View of Cluster from system ID 19509 node: AJAX 22-FEB-2001 13:00:54

| SYSTEMS          |  |                      | MEMBERS |        |                   |
|------------------|--|----------------------|---------|--------|-------------------|
| NODE             | HW_TYPE                                | SOFTWARE             | VOTES   | STATUS | TRANSITION_TIME   |
| AJAX<br>HSJ012   | AlphaServer 8400 5/440<br>HSJ4         | VMS V7.2<br>HSJ V36J | 1       | MEMBER | 30-JAN-2001 10:00 |
| HELENA<br>E      | VAX 6000-540<br>AlphaServer 8400 5/440 | VMS V7.2<br>VMS V7.2 | 1       | MEMBER | 12-JAN-2001 14:25 |
| HSJ019<br>HSJ018 | HSJ5<br>HSJ5                           | HSJ V52J<br>HSJ V52J | 1       | MEMBER | 20-DEC-2000 16:40 |
| DIMOND<br>HSJ004 | VAX 6000-540<br>HSJ4                   | VMS V7.2<br>HSJ V32J | 1       | MEMBER | 31-JAN-2001 13:50 |

VM-0753A-AI

Because SHOW CLUSTER information covers approximately 100 fields of data, the display can quickly extend beyond screen limits. Therefore, the utility provides mechanisms to help you control the display of data. These mechanisms include the following ones:

- SHOW CLUSTER qualifiers

## SHOW CLUSTER

### 7.1 SHOW CLUSTER Description

- SHOW CLUSTER commands
- A default keypad, which can be redefined
- An initialization file to format the display
- Command procedures to control the display

SHOW CLUSTER has a number of qualifiers and commands, and a definable keypad that allow you to customize the display. You can rearrange the position of windows, scroll their contents, or change the interval at which the display is updated. This chapter contains reference information for the SHOW CLUSTER qualifiers and commands. Appendix C describes how to use the keypad.

Over time, as you determine the most valuable classes and fields of data for the SHOW CLUSTER report, you can create a startup initialization file that establishes your default report format. You can also build command procedures and define a keypad to use while running SHOW CLUSTER interactively.

By customizing SHOW CLUSTER output, you can display only data that is relevant to your installation. Creating the initialization file `SHOW_CLUSTER$INIT:SHOW_CLUSTER.INI` is described in *OpenVMS System Manager's Manual, Volume 2: Tuning, Monitoring, and Complex Systems*.

By customizing the SHOW CLUSTER keypad, you can redefine default keypad functions to be more site specific. Using SHOW CLUSTER keypad commands is described in Appendix C.

## 7.2 SHOW CLUSTER Usage Summary

The Show Cluster utility (SHOW CLUSTER) monitors the activity and performance of an OpenVMS Cluster system, and outputs the information to your default terminal or to a specified device or file.

### Format

```
SHOW CLUSTER [/qualifier[, . . . ]]
```

#### Parameters

None.

### Description

To invoke SHOW CLUSTER, enter the following command:

```
$ SHOW CLUSTER
```

If you specify the command without any qualifiers, SHOW CLUSTER displays a single cluster report and then returns control to the DCL level. To invoke a continuous SHOW CLUSTER display, enter the following command:

```
$ SHOW CLUSTER/CONTINUOUS
```

In a continuous display, you can control report output with SHOW CLUSTER commands. You can direct SHOW CLUSTER output to a file or device other than to `SYS$OUTPUT` by specifying the `/OUTPUT` qualifier with the SHOW CLUSTER command.

## SHOW CLUSTER

### 7.2 SHOW CLUSTER Usage Summary

To exit from a continuous display and return to the DCL level, enter the EXIT command or press Ctrl/Z. To exit from SHOW CLUSTER without erasing the screen, press Ctrl/C. To interrupt SHOW CLUSTER, press Ctrl/Y.

### 7.3 SHOW CLUSTER Qualifiers

This section describes and provides examples of the SHOW CLUSTER qualifiers. The following table describes the qualifiers:

| Qualifier         | Description   |
|-------------------|---|
| /BEGINNING=time   | Specifies the time that the SHOW CLUSTER session is to begin.   |
| /CONTINUOUS       | Controls whether SHOW CLUSTER runs as a continuously updating display.                                |
| /ENDING=time      | Specifies the time that the SHOW CLUSTER session is to end.   |
| /INTERVAL=seconds | Specifies the number of seconds that display information remains on the screen before it is updated.  |
| /OUTPUT=file-spec | Directs the output from SHOW CLUSTER to the specified file instead of the current SYS\$OUTPUT device. |



## **/BEGINNING=time**

Specifies the time that the SHOW CLUSTER session is to begin. You can specify an absolute time, a delta time, or a combination of the two. Observe the syntax rules for time values described in the *OpenVMS User's Manual*.

If you specify a future time, your process is placed in a state of hibernation until the specified time. Use this qualifier with the /OUTPUT and /ENDING qualifiers to run SHOW CLUSTER without direct user intervention.

### **Format**

/BEGINNING=time

### **Parameter**

#### **time**

You can specify time as an absolute time expressed as [dd-mmm-yyyy[:]] [hh:mm:ss.cc], or a delta time expressed as [dddd-][hh:mm:ss.cc], or a combination of the two. Observe the syntax rules for time values described in the *OpenVMS User's Manual*.

### **Examples**

1. \$ SHOW CLUSTER/BEGINNING=31-OCT-2002:20:30

In this example, specifying an absolute time, SHOW CLUSTER produces a single display at 8:30 P.M. on October 31, 2002.

2. \$ SHOW CLUSTER/CONTINUOUS/BEGINNING=31-OCT-2002:21:30

In this example, specifying an absolute time, SHOW CLUSTER begins a continuous display at 9:30 P.M. on October 31, 2002.

3. \$ SHOW CLUSTER/BEGINNING=7-:30

In this example, specifying a delta time, SHOW CLUSTER produces a single display 7 days and 30 minutes from now.

## SHOW CLUSTER /CONTINUOUS

---

### /CONTINUOUS

Controls whether SHOW CLUSTER runs as a continuously updating display. If you omit the qualifier, SHOW CLUSTER produces a single display and returns control to the DCL command level.

Running SHOW CLUSTER in the continuous mode allows you to use SHOW CLUSTER commands to control the display.

### Format

/CONTINUOUS

### Example

```
$ SHOW CLUSTER/CONTINUOUS
```

In this example, SHOW CLUSTER begins to display a continuous report that is updated every 15 seconds.

## **/ENDING=time**

Specifies the time that the SHOW CLUSTER session is to end. You can specify an absolute time, a delta time, or a combination of the two. Observe the syntax rules for time values described in the *OpenVMS User's Manual*.

Use this qualifier with the /BEGINNING and /OUTPUT qualifiers to run SHOW CLUSTER without direct user intervention.

## **Format**

/ENDING=time

## **Parameter**

### **time**

You can specify time as an absolute time expressed as [dd-mmm-yyyy[:]][hh:mm:ss.cc], or a delta time expressed as [ddd-][hh:mm:s.cc], or a combination of the two. Observe the syntax rules for time values described in the *OpenVMS User's Manual*.

## **Example**

```
$ SHOW CLUSTER/CONTINUOUS/ENDING=31-OCT-2002:15:30
```

In this example, SHOW CLUSTER begins a continuous display now and ends the display at 3:30 P.M. on October 31, 2002.

## SHOW CLUSTER /INTERVAL=seconds

---

### /INTERVAL=seconds

Specifies the number of seconds that display information remains on the screen before it is updated. By default, the interval time is 15 seconds.

### Format

/INTERVAL=seconds

### Parameter

#### **seconds**

The number of seconds between display updates.

### Example

```
$ SHOW CLUSTER/INTERVAL=5
```

In this example, SHOW CLUSTER displays a continuous report that is updated every 5 seconds.

---

## **/OUTPUT=file-spec**

Directs the output from SHOW CLUSTER to the specified file instead of the current SYS\$OUTPUT device.

SHOW CLUSTER output is always in printable file format, regardless of the file or device type specified. Output can be up to 132 columns wide and can be sent to any file, terminal, or print device.

You can also direct output to a file with the WRITE command.

### **Format**

/OUTPUT=file-spec

### **Parameter**

#### **file-spec**

The name of the file or device to which SHOW CLUSTER output is directed. The default file name is SHOW\_CLUSTER.LIS.

You can direct output to a device other than SYS\$OUTPUT by specifying a valid device name.

### **Example**

```
$ SHOW CLUSTER/OUTPUT=[OMALLEY]CLUSTER
```

In this example, SHOW CLUSTER produces one report and directs it to the file CLUSTER.LIS;1 in the directory OMALLEY.

---

## **7.4 SHOW CLUSTER Commands**

Once you start a continuous SHOW CLUSTER display session, you can use SHOW CLUSTER commands to control the session. The following table describes each command:

| <b>Command Name</b>   | <b>Description</b>  |
|-----------------------|---|
| @ (Execute Procedure) | Executes a command procedure file that contains SHOW CLUSTER commands.  |
| ADD CIRCUITS          | Adds all currently enabled CIRCUITS class fields to the SHOW CLUSTER display.   |
| ADD CLUSTER           | Adds all currently enabled CLUSTER class fields to the SHOW CLUSTER display.  |
| ADD CONNECTIONS       | Adds all currently enabled CONNECTIONS class fields to the SHOW CLUSTER display. Optionally, the command adds connections according to state or name. |
| ADD COUNTERS          | Adds all currently enabled COUNTERS class fields to the SHOW CLUSTER display.   |

## SHOW CLUSTER

### 7.4 SHOW CLUSTER Commands

| Command Name       | Description   |
|--------------------|---|
| ADD CREDITS        | Adds all currently enabled CREDITS class fields to the SHOW CLUSTER display.  |
| ADD ERRORS         | Adds all currently enabled ERRORS class fields to the SHOW CLUSTER display.   |
| ADD (Field)        | Enables the display of specific fields of SHOW CLUSTER information.   |
| ADD LOCAL_PORTS    | Adds all currently enabled LOCAL_PORTS class fields to the SHOW CLUSTERS display.   |
| ADD MEMBERS        | Adds all currently enabled MEMBERS class fields to the SHOW CLUSTER display.  |
| ADD SYSTEMS        | Adds all currently enabled SYSTEMS class fields to the SHOW CLUSTER display for all active systems or for selected systems.   |
| DEFINE/KEY         | Associates an equivalence string and set of attributes with a key on the terminal keyboard.   |
| DESELECT           | Terminates the selection of a previously selected window.   |
| EXIT               | Terminates the SHOW CLUSTER display and returns control to the DCL command level.   |
| HELP               | Provides online help information for using SHOW CLUSTER commands, parameters, and qualifiers. Press Ctrl/Z to exit.   |
| INITIALIZE         | Resets the display using the original default values for field names, class names, and field widths. It also restores any systems that were removed from the display by the REMOVE SYSTEMS command. |
| MOVE               | Moves a selected window to a specified position.  |
| PAN                | Exhibits a wide display area, a part at a time, as though being unrolled.   |
| REFRESH            | Clears the screen, removes extraneous characters, and updates all fields.   |
| REMOVE CIRCUITS    | Removes CIRCUITS class information from the SHOW CLUSTER display.   |
| REMOVE CLUSTER     | Removes CLUSTER class information from the SHOW CLUSTER display.  |
| REMOVE CONNECTIONS | Removes CONNECTIONS class information from the SHOW CLUSTER display.  |
| REMOVE COUNTERS    | Removes COUNTERS class information from the SHOW CLUSTER display.   |
| REMOVE CREDITS     | Removes CREDITS class information from the SHOW CLUSTER display.  |
| REMOVE ERRORS      | Removes ERRORS class information from the SHOW CLUSTER display.   |
| REMOVE (Field)     | Disables the display of specific fields of SHOW CLUSTER information.  |
| REMOVE LOCAL_PORTS | Removes LOCAL_PORTS class information from the SHOW CLUSTER display.  |

## SHOW CLUSTER 7.4 SHOW CLUSTER Commands

| Command Name         | Description   |
|----------------------|---|
| REMOVE MEMBERS       | Removes MEMBERS class information from the SHOW CLUSTER display.  |
| REMOVE SYSTEMS       | Removes SYSTEMS class information from the SHOW CLUSTER display.  |
| SAVE                 | Allows you to build a startup initialization file or a command procedure that creates the current display so you can restore the display at a later time. |
| SCROLL               | Scrolls a window.   |
| SELECT               | Designates which window to scroll or move.  |
| SET AUTO_POSITIONING | Enables or disables the automatic positioning of windows within a display.  |
| SET (Field)          | Modifies the characteristics of particular fields within the display.   |
| SET FUNCTION         | Enables one of the following SHOW CLUSTER functions: EDIT, MOVE, PAN, or SCROLL.  |
| SET INTERVAL         | Changes the interval time between display updates. The default interval time is 15 seconds.   |
| SET SCREEN           | Sets the terminal to a display of up to 511 columns.  |
| WRITE                | Outputs the current display to a file that can be printed on a hardcopy device.   |

## SHOW CLUSTER

### @ (Execute Procedure)

---

#### @ (Execute Procedure)

Executes a command procedure file that contains SHOW CLUSTER commands.

#### Format

@ file-spec

#### Parameter

##### **file-spec**

Specifies the name of the file that contains the commands to be executed. If you omit the file type, the default file type .COM is used. No wildcard characters are allowed in the file specification.

#### Qualifiers

None.

#### Description

The execute procedure (@) command allows you to execute a set of SHOW CLUSTER commands that are contained in a file. For example, a command procedure file might contain a set of commands to customize a SHOW CLUSTER display. You can use any valid SHOW CLUSTER commands in the command procedure. You can nest command procedures up to 16 levels deep.

SHOW CLUSTER looks for the command procedure in the directory specified by the logical name SHOW\_CLUSTER\$INIT. If SHOW\_CLUSTER\$INIT is not defined or does not include a directory specification, the utility looks for the command procedure in the current default directory.

#### Example

```
COMMAND> @MYFILE
```

This command executes the command procedure MYFILE.COM. Because no file type is specified, the file type defaults to .COM.



---

## **ADD CIRCUITS**

Adds all currently enabled CIRCUITS class fields to the SHOW CLUSTER display. The CIRCUITS class contains information about the virtual circuits on systems in the cluster.

### **Format**

ADD CIRCUITS [/qualifier[, . . . ]]

### **Parameters**

None.

### **Qualifiers**

**/ALL**

Specifies that all fields in this class are to be added to the display.

**/TYPE=ALL**

Specifies that all types of circuits be included in the display, including formative, open, and closing circuits.

**/TYPE=OPEN**

**/TYPE=NOOPEN**

Controls whether either open circuits or nonopen circuits are added to the display.

### **Description**

The ADD CIRCUITS command adds CIRCUITS class information to the SHOW CLUSTER display. This information includes data for all currently enabled fields in the CIRCUITS class. By default, the following fields are enabled:

RPORT\_NUM—remote port number  
RP\_TYPE—remote port type  
CIR\_STATE—circuit state

For a list of all CIRCUITS class fields, see Table 7–2.

Use the ADD CIRCUITS command together with the REMOVE CIRCUITS command to turn the display of CIRCUITS class information on and off. If you remove the CIRCUITS class from the display and add it again without changing any fields, all of the same fields are displayed again. If, however, you remove the CIRCUITS class and add new CIRCUITS class fields, all previously enabled fields are disabled, and only the newly added fields are displayed.

### **Examples**

1. COMMAND> ADD CIRCUITS

This command adds CIRCUITS class information to the display. This information includes all types of circuits for all enabled CIRCUITS class fields.

2. COMMAND> ADD CIRCUITS/TYPE=OPEN

This command adds all open circuits to the SHOW CLUSTER display.

## SHOW CLUSTER ADD CIRCUITS

```
3.  COMMAND> REMOVE CIRCUITS
    COMMAND> ADD RP_OWNER
    COMMAND> REMOVE CIRCUITS
        .
        .
        .
    COMMAND> ADD CIRCUITS
```

The ADD CIRCUITS command in this example sequence adds CIRCUITS class information to the SHOW CLUSTER display. The REMOVE CIRCUITS command removes the CIRCUITS class from the display.

The ADD RP\_OWNER command adds the CIRCUITS class field RP\_OWNER to the display. As a result, all other CIRCUITS class fields are disabled. When the CIRCUITS class is removed and added again, only the RP\_OWNER field is displayed.

---

## **ADD CLUSTER**

Adds all currently enabled CLUSTER class fields to the SHOW CLUSTER display.

### **Format**

ADD CLUSTER

### **Parameters**

None.

### **Qualifier**

**/ALL**

Specifies that all fields in this class are to be added to the display.

### **Description**

The ADD CLUSTER command adds CLUSTER class information to the SHOW CLUSTER display. This information includes data for all currently enabled fields in the CLUSTER class. By default, the CLUSTER class includes the following fields:

- CL\_EXPECTED\_VOTES—number of cluster votes expected
- CL\_QUORUM—cluster quorum
- CL\_VOTES—cluster votes
- QF\_VOTE—quorum disk contributes a vote
- CL\_MEMBERS—current cluster members
- FORMED—when quorum was formed
- LAST\_TRANSITION—last change in cluster membership

For a list of all CLUSTER class fields, see Table 7–3.

Use the ADD CLUSTER command with the REMOVE CLUSTER command to turn the display of CLUSTER class information on and off. If you remove the CLUSTER class from the display and add it again without changing any fields, all of the same fields are displayed again. If, however, you remove the CLUSTER class and add new CLUSTER class fields, all previously enabled fields are disabled, and only the newly added fields are displayed.

### **Examples**

1. COMMAND> ADD CLUSTER

This command adds CLUSTER class information to the display. This information includes all enabled CLUSTER class fields.

## SHOW CLUSTER ADD CLUSTER

```
2.  COMMAND> REMOVE CLUSTER
    COMMAND> ADD CL_QUORUM
    COMMAND> REMOVE CLUSTER
    .
    .
    .
    COMMAND> ADD CLUSTER
```

The ADD CLUSTER command in this example adds CLUSTER class information to the SHOW CLUSTER display. The first command in the sequence removes the CLUSTER class from the display. The second command, ADD CL\_QUORUM, adds the CLUSTER class field CL\_QUORUM to the display. As a result, all other CLUSTER class fields are disabled. When the CLUSTER class is removed and added again, only the CL\_QUORUM field is displayed.

---

## **ADD CONNECTIONS**

Adds all currently enabled CONNECTIONS class fields to the SHOW CLUSTER display. Optionally, the command adds connections according to state or name.

### **Format**

```
ADD CONNECTIONS [/qualifier[, . . . ]]
```

### **Parameters**

None.

### **Qualifiers**

#### **/ALL**

Specifies that all fields in this class are to be added to the display.

#### **/NAME=ALL**

Restores processes removed from the display with the command REMOVE CONNECTIONS/NAME=local-process-name.

#### **/NAME=local-process-name**

Adds the connection associated with the specified local process name, as displayed in the LOC\_PROC\_NAME field of the CONNECTIONS class.

A local process name can contain up to 16 characters. If the name is abbreviated, SHOW CLUSTER adds all local process names matching the abbreviation.

#### **/TYPE=ALL**

Specifies that all types of connections on each circuit are displayed. For a listing of the possible states a connection can be in, see the description of the CON\_STATE field in Table 7-4. By default, the ADD CONNECTIONS command without any qualifiers displays all types of connections.

#### **/TYPE=OPEN**

#### **/TYPE=NOOPEN**

Controls whether connections in the open state or the nonopen state are to be added to the SHOW CLUSTER display.

### **Description**

The ADD CONNECTIONS command adds CONNECTIONS class information to the SHOW CLUSTER display. This information includes data for all currently enabled fields in the CONNECTIONS class.

By default, the following CONNECTIONS class fields are enabled:

- LOC\_PROC\_NAME—local process name
- CON\_STATE—connection state

For a list of all CONNECTIONS class fields, see Table 7-4.

Use the ADD CONNECTIONS command together with the REMOVE CONNECTIONS command to turn the display of CONNECTIONS class information on and off. If you remove the CONNECTIONS class from the display and add it again without changing any fields, all of the same fields are displayed again. If, however, you remove the CONNECTIONS class and add new

## SHOW CLUSTER ADD CONNECTIONS

CONNECTIONS class fields, all previously enabled fields are disabled, and only the newly added fields are displayed.

### Examples

1. `COMMAND> ADD CONNECTIONS`

This command adds CONNECTIONS class information to the display. This information includes all enabled CONNECTIONS class fields.

2. `COMMAND> ADD CONNECTIONS/NAME=(MSCP$DISK,VMS$VMScluster)`

This command adds all connections associated with the process MSCP\$DISK and the process VMS\$VMScluster to the SHOW CLUSTER display.

3. `COMMAND> ADD CONNECTIONS/TYPE=OPEN`

This command adds all open connections to the SHOW CLUSTER display.

4. `COMMAND> REMOVE CONNECTIONS`  
`COMMAND> ADD SCS STATE`  
`COMMAND> REMOVE CONNECTIONS`

.  
.  
.

- `COMMAND> ADD CONNECTIONS`

The ADD CONNECTIONS command in this example adds CONNECTIONS class information to the SHOW CLUSTER display. The first command in the sequence removes the CONNECTIONS class from the display. The second command, ADD SCS\_STATE, adds the CONNECTIONS class field SCS\_STATE to the display. As a result, all other CONNECTIONS class fields are disabled. When the CONNECTIONS class is removed and added again, only the SCS\_STATE field is displayed.

---

## **ADD COUNTERS**

Adds all currently enabled COUNTERS class fields to the SHOW CLUSTER display.

### **Format**

ADD COUNTERS

### **Parameters**

None.

### **Qualifier**

**/ALL**

Specifies that all fields in this class are to be added to the display.

### **Description**

The ADD COUNTERS command adds COUNTERS class information to the SHOW CLUSTER display. This information includes data for all currently enabled fields in the COUNTERS class.

By default, the following COUNTERS fields are enabled:

- DGS\_SENT—datagrams sent
- DGS\_RCVD—datagrams received
- MSGG\_SENT—messages sent
- MSGG\_RCVD—messages received

For a list of all COUNTERS class fields, see Table 7–5.

Use the ADD COUNTERS command together with the REMOVE COUNTERS command to turn the display of COUNTERS class information on and off. If you remove the COUNTERS class from the display and add it again without changing any fields, all of the same fields are displayed again. If, however, you remove the COUNTERS class and add new COUNTERS class fields, all previously enabled fields are disabled, and only the newly added fields are displayed.

### **Examples**

1. COMMAND> ADD COUNTERS

This command adds COUNTERS class information to the display. This information includes all enabled COUNTERS class fields.

2. COMMAND> REMOVE COUNTERS  
COMMAND> ADD MSGG\_SENT  
COMMAND> REMOVE COUNTERS

·  
·  
·

COMMAND> ADD COUNTERS

The ADD COUNTERS command in this example sequence adds COUNTERS class information to the SHOW CLUSTER display. The first command removes the COUNTERS class from the display. The second command, ADD MSGG\_SENT, adds the COUNTERS class field MSGG\_SENT to the

**SHOW CLUSTER**  
**ADD COUNTERS**

display. As a result, all other COUNTERS class fields are disabled. When the COUNTERS class is removed and added again, only the MSGS\_SENT field is displayed.



---

## **ADD CREDITS**

Adds all currently enabled CREDITS class fields to the SHOW CLUSTER display.

### **Format**

ADD CREDITS

### **Parameters**

None.

### **Qualifier**

**/ALL**

Specifies that all fields in this class are to be added to the display. By default, the ADD CREDITS command, used without any qualifiers, displays all the CREDITS class fields.

### **Description**

The ADD CREDITS command adds CREDITS class information to the SHOW CLUSTER display. This information includes data for all currently enabled fields in the CREDITS class.

By default, all CREDITS class fields are enabled. For a list of all CREDITS class fields, see Table 7–6.

Use the ADD CREDITS command together with the REMOVE CREDITS command to turn the display of CREDITS class information on and off. If you remove the CREDITS class from the display and then add it again without changing any fields, all of the same fields are displayed again. If, however, you remove the CREDITS class and add new CREDITS class fields, all previously enabled fields are disabled, and only the newly added fields are displayed.

### **Examples**

1. `COMMAND> ADD CREDITS`

This command adds CREDITS class information to the display. This information includes all enabled CREDITS class fields.

2. `COMMAND> REMOVE CREDITS`  
`COMMAND> ADD MIN_REC`  
`COMMAND> REMOVE CREDITS`

·  
·  
·

`COMMAND> ADD CREDITS`

The ADD CREDITS command in this example sequence adds CREDITS class information to the SHOW CLUSTER display. The first command removes the CREDITS class from the display. The second command, ADD MIN\_REC, adds the CREDITS class field MIN\_REC to the display. As a result, all other CREDITS class fields are disabled. When the CREDITS class is removed and added again, only the MIN\_REC field is displayed.

# SHOW CLUSTER ADD ERRORS

---

## ADD ERRORS

Adds all currently enabled ERRORS class fields to the SHOW CLUSTER display.

### Format

ADD ERRORS

### Parameters

None.

### Qualifier

**/ALL**

Specifies that all fields in this class are to be added to the display. By default, ADD ERRORS, used without any field qualifiers, displays all the fields in the ERRORS class.

### Description

The ADD ERRORS command adds ERRORS class information to the SHOW CLUSTER display. This information includes data for all currently enabled fields in the ERRORS class.

By default, all ERRORS class fields are enabled. For a list of all ERRORS class fields, see Table 7–7.

Use the ADD ERRORS command together with the REMOVE ERRORS command to turn the display of ERRORS class information on and off. If you remove the ERRORS class from the display and add it again without changing any fields, all of the same fields are displayed again. If, however, you remove the ERRORS class and add new ERRORS class fields, all previously enabled fields are disabled, and only the newly added fields are displayed.

### Examples

1. COMMAND> ADD ERRORS

This command adds ERRORS class information to the display. This information includes all enabled ERRORS class fields.

2. COMMAND> REMOVE ERRORS  
COMMAND> ADD ERT\_MAX  
COMMAND> REMOVE ERRORS

·  
·  
·

COMMAND> ADD ERRORS

The ADD ERRORS command in this example sequence adds ERRORS class information to the SHOW CLUSTER display. The first command removes the ERRORS class from the display. The second command, ADD ERT\_MAX, adds the ERRORS class field ERT\_MAX to the display. As a result, all other ERRORS class fields are disabled. When the ERRORS class is removed and added again, only the ERT\_MAX field is displayed.

## **ADD (Field)**

Enables the display of specific fields of SHOW CLUSTER information.

### **Format**

ADD field-name[. . . ]

#### **CIRCUITS**

The CIRCUITS class contains information about the virtual circuits on a system, such as the local port name, the remote port type and number, the number of connections on the circuit, and the circuit state.

See Table 7–2 for a table containing the fields in the CIRCUITS class.

#### **CLUSTER**

The CLUSTER class contains general information about the cluster, such as the time it was formed, the last time a system joined or left the cluster, and the cluster quorum.

See Table 7–3 for a table containing the fields in the CLUSTER class.

#### **CONNECTIONS**

The CONNECTIONS class contains information about connections established over a virtual circuit, such as the names of the local and remote processes, and the state of the connection.

See Table 7–4 for a table containing the fields in the CONNECTIONS class.

#### **COUNTERS**

The COUNTERS class displays statistics on connection traffic, such as the number of application datagrams or the number of application messages that have been sent or received.

See Table 7–5 for a table containing the fields in the COUNTERS class.

#### **CREDITS**

The CREDITS class displays the send and receive credit counts for each connection.

See Table 7–6 for a table containing the fields in the CREDITS class.

#### **ERRORS**

The ERRORS class displays a count of the errors on each port, along with information about the feasibility of reinitializing a port.

See Table 7–7 for a table containing the fields in the ERRORS class.

#### **LOCAL\_PORTS**

The LOCAL\_PORTS class displays information about the local system interface to the cluster, such as the name, number, and status of each port, and the number of entries in the queues associated with each port.

See Table 7–8 for a table containing the fields in the LOCAL\_PORTS class.

#### **MEMBERS**

The MEMBERS class contains information about active systems in the cluster, such as their identification numbers and membership status.

See Table 7–9 for a table containing the fields in the MEMBERS class.

## SHOW CLUSTER ADD (Field)

### SYSTEMS

The SYSTEMS class lists information about all systems in the cluster, such as their identification numbers, node names, hardware types, and software versions.

See Table 7–10 for a table containing the fields in the SYSTEMS class.

### Qualifiers

None.

### Description

The ADD (Field) command enables and adds specific fields of information to a SHOW CLUSTER display. When you add a field for a class that is not currently being displayed, the class heading of that field is added to the display. The qualifier /ALL on any ADD (Class) command adds all fields in the class to the display.

To remove a field from the SHOW CLUSTER display, enter the REMOVE (Field) command.

### Examples

1. `COMMAND> ADD SEND`

This command enables the CREDITS class field SEND and adds it to the SHOW CLUSTER display.

2. `COMMAND> ADD REM_STATE,REM_CONID,LOC_CONID`

This command enables the CIRCUITS class field REM\_STATE and the CONNECTIONS class fields REM\_CONID and LOC\_CONID, and adds them to the SHOW CLUSTER display.

---

## **ADD LOCAL\_PORTS**

Adds all currently enabled LOCAL\_PORTS class fields to the SHOW CLUSTER display.

### **Format**

ADD LOCAL\_PORTS

### **Parameters**

None.

### **Qualifier**

**/ALL**

Specifies that all fields in this class are to be added to the display.

### **Description**

The ADD LOCAL\_PORTS command adds LOCAL\_PORTS class information to the SHOW CLUSTER display. This information includes data for all currently enabled fields in the LOCAL\_PORTS class.

By default, the following fields are enabled:

NAME  
LP\_STATUS—port status  
PORT\_NUM—port number  
DGS\_FREE—free datagrams queued  
MSG\_FREE—free messages queued  
OPEN\_CIRCS—open circuits  
FORM\_CIRCS—formative circuits

For a list of all LOCAL\_PORTS class fields, see Table 7–8.

Use the ADD LOCAL\_PORTS command with the REMOVE LOCAL\_PORTS command to turn the display of LOCAL\_PORTS class information on and off. If you remove the LOCAL\_PORTS class from the display and add it again without changing any fields, all of the same fields are displayed again. If, however, you remove the LOCAL\_PORTS class and add new LOCAL\_PORTS class fields, all previously enabled fields are disabled, and only the newly added fields are displayed.

### **Examples**

1. COMMAND> ADD LOCAL\_PORTS

This command adds LOCAL\_PORTS class information to the display. This information includes all enabled LOCAL\_PORTS class fields.

## SHOW CLUSTER ADD LOCAL\_PORTS

```
2.  COMMAND> REMOVE LOCAL_PORTS
    COMMAND> ADD LB_STATUS
    COMMAND> REMOVE LOCAL_PORTS
    .
    .
    .
    COMMAND> ADD LOCAL_PORTS
```

The ADD LOCAL\_PORTS command in this example sequence adds LOCAL\_PORTS class information to the SHOW CLUSTER display. The first command removes the LOCAL\_PORTS class from the display. The second command, ADD LB\_STATUS, adds the LOCAL\_PORTS class field LB\_STATUS to the display. As a result, all other LOCAL\_PORTS class fields are disabled. When the LOCAL\_PORTS class is removed and added again, only the LB\_STATUS field is displayed.

---

## **ADD MEMBERS**

Adds all currently enabled MEMBERS class fields to the SHOW CLUSTER display.

### **Format**

ADD MEMBERS

### **Parameters**

None.

### **Qualifier**

**/ALL**

Specifies that all fields in this class are to be added to the display.

### **Description**

The ADD MEMBERS command adds MEMBERS class information to the SHOW CLUSTER display. This information includes data for all currently enabled fields in the MEMBERS class.

By default, only the STATUS field is enabled. For a list of all MEMBERS class fields, see Table 7–9.

Use the ADD MEMBERS command with the REMOVE MEMBERS command to turn the display of MEMBERS class information on and off. If you remove the MEMBERS class from the display and add it again without changing any fields, all of the same fields are displayed again. If, however, you remove the MEMBERS class and add new MEMBERS class fields, all previously enabled fields are disabled, and only the newly added fields are displayed.

### **Examples**

1. `COMMAND> ADD MEMBERS`

This command adds MEMBERS class information to the display. This information includes all enabled MEMBERS class fields.

2. `COMMAND> REMOVE MEMBERS`  
`COMMAND> ADD VOTES`  
`COMMAND> REMOVE MEMBERS`  
.  
.  
.  
`COMMAND> ADD MEMBERS`

The ADD MEMBERS command in this example sequence adds MEMBERS class information to the SHOW CLUSTER display. The first command removes the MEMBERS class from the display. The second command, ADD VOTES, adds the MEMBERS class field VOTES to the display. As a result, all other MEMBERS class fields are disabled. When the MEMBERS class is removed and added again, only the VOTES field is displayed.

## SHOW CLUSTER ADD SYSTEMS

---

### ADD SYSTEMS

Adds all currently enabled SYSTEMS class fields to the SHOW CLUSTER display for all active systems or for selected systems.

#### Format

```
ADD SYSTEMS [/qualifier[, . . . ]]
```

#### Parameters

None.

#### Qualifiers

##### **/ALL**

Specifies that all fields in the SYSTEMS class are to be added to the display.

##### **/ID=ALL**

Restores the display after selectively removing systems by ID.

##### **/ID=system-id**

Specifies, by system identification number, systems to be added to the SHOW CLUSTER display. The *system-id* can be any identification number displayed in the SYS\_ID field of the SYSTEMS class. When using a hexadecimal value for an identifier, precede the number with the characters %X.

The /ID qualifier affects all information displayed about the specified system, not just information in the SYSTEMS class display.

##### **/NODE=ALL**

Restores the display after selectively removing systems by node name.

##### **/NODE=node-name**

Specifies, by node name, systems to be added to the SHOW CLUSTER display. The *node-name* can be any node displayed in the NODE field of the SYSTEMS class, and it can be enclosed in quotation marks. The /NODE qualifier affects all information displayed about the specified node, not just information in the SYSTEMS class display.

##### **/TYPE=ALL**

Restores the display after selectively removing systems by type.

##### **/TYPE=hardware-type**

Specifies, by hardware type, systems to be added to the SHOW CLUSTER display. You can specify any of the types shown in the HW\_TYPE field, and you must enclose the type in quotation marks; for example, "VAX 8800". Because the quoted text may be abbreviated, it is possible, for example, to add VAXstation II and VAXstation 2000 systems with a single command. Multiple types may be specified if enclosed in parentheses and separated by commas. Hardware types are not case sensitive.

The /TYPE qualifier affects all information displayed about the specified hardware type, not just information in the SYSTEMS class display.



## Description

The ADD SYSTEMS command adds SYSTEMS class information to the SHOW CLUSTER display. This information includes data for all currently enabled fields in the SYSTEMS class. By default, the following fields are enabled:

NODE  
SOFTWARE

For a list of all SYSTEMS class fields, see Table 7–10.

Use the ADD SYSTEMS command with the REMOVE SYSTEMS command to turn the display of SYSTEMS class information on and off. If you remove the SYSTEMS class from the display and add it again without changing any fields, all of the same fields are displayed again. If, however, you remove the SYSTEMS class and add new SYSTEMS class fields, all previously enabled fields are disabled, and only the newly added fields are displayed.

## Examples

1. COMMAND> ADD SYSTEMS

This command adds SYSTEMS class information to the display. This information includes all enabled SYSTEMS class fields.

2. COMMAND> ADD SYSTEMS/NODE=(PISHTA,ELF)

This command adds the nodes PISHTA and ELF to the SHOW CLUSTER display, reporting all currently enabled information about the nodes.

3. COMMAND> ADD SYSTEMS/TYPE=("VAX 8800","MicroVAX 2000")

This command adds all VAX 8800 and MicroVAX 2000 processors to the SHOW CLUSTER display, reporting all currently enabled information about those hardware types.

4. COMMAND> REMOVE SYSTEMS  
COMMAND> ADD SYS\_ID  
COMMAND> REMOVE SYSTEMS

·  
·  
·

COMMAND> ADD SYSTEMS

The ADD SYSTEMS command in this example sequence adds SYSTEMS class information to the SHOW CLUSTER display. The first command removes the SYSTEMS class from the display. The second command, ADD SYS\_ID, adds the SYSTEMS class field SYS\_ID to the display. As a result, all other SYSTEMS class fields are disabled. When the SYSTEMS class is removed and added again, only the SYS\_ID field is displayed.

# SHOW CLUSTER DEFINE/KEY

---

## DEFINE/KEY

Associates an equivalence string and set of attributes with a key on the terminal keyboard. The /KEY qualifier is required.

### Format

DEFINE/KEY key-name equivalence-string

### Parameters

#### key-name

Specifies the name of the key that you are defining. Use the following key names when defining keys:

| Key Name         | LK201       | VT100     | VT52      |
|------------------|-------------|-----------|-----------|
| PF1              | PF1         | PF1       | [blue]    |
| PF2              | PF2         | PF2       | [red]     |
| PF3              | PF3         | PF3       | [gray]    |
| PF4              | PF4         | PF4       | - -       |
| KP0, KP1 to KP9  | 0, 1 to 9   | 0, 1 to 9 | 0, 1 to 9 |
| PERIOD           | .           | .         | .         |
| COMMA            | ,           | ,         | n/a       |
| MINUS            | -           | -         | n/a       |
| ENTER            | Enter       | ENTER     | ENTER     |
| Find (E1)        | Find        | --        | --        |
| Insert Here (E2) | Insert Here | --        | --        |
| Remove (E3)      | Remove      | --        | --        |
| Select (E4)      | Select      | --        | --        |
| Prev Screen (E5) | Prev Screen | --        | --        |
| Next Screen (E6) | Next Screen | --        | --        |
| HELP             | Help        | --        | --        |
| DO               | Do          | --        | --        |
| F17 to F20       | F17 to F20  | --        | --        |

#### equivalence-string

Specifies the string to be processed when you press the key. The string can be a SHOW CLUSTER command. If the string contains any spaces, enclose the equivalence string in quotation marks.

### Qualifiers

#### /ECHO (default)

#### /NOECHO

Determines whether the equivalence string is displayed on your screen after the key has been pressed. You cannot use /NOECHO with the /NOTERMINATE qualifier.

**/ERASE**

**/NOERASE (default)**

Determines whether the current line is erased before the key translation is inserted.

**/IF\_STATE=(state-name, . . . )**

**/NOIF\_STATE**

Specifies a list of one or more states, one of which must take effect for the key definition to be in effect. If you omit the /IF\_STATE qualifier or use /NOIF\_STATE, the current state is used.

**/LOCK\_STATE**

**/NOLOCK\_STATE (default)**

Specifies that the state set by the /SET\_STATE qualifier remain in effect until explicitly changed. If you use the /NOLOCK\_STATE qualifier, the state set by /SET\_STATE is in effect only for the next definable key that you press or for the next read-terminating character that you type.

The /LOCK\_STATE qualifier can be specified only with the /SET\_STATE qualifier.

**/LOG (default)**

**/NOLOG**

Controls whether the system displays a message indicating that the key definition has been successfully created.

**/SET\_STATE=state-name**

**/NOSET\_STATE (default)**

Causes the specified state-name to be set when the key is pressed. The state name can be any alphanumeric string.

If you omit the SET\_STATE qualifier or use /NOSET\_STATE, the current state that was locked remains in effect. If you have not included this qualifier with a key definition, use the DCL command SET KEY to change the current state.

**/TERMINATE**

**/NOTERMINATE (default)**

Specifies whether the current equivalence string is to be terminated (that is, processed) when the key is pressed. Pressing Return has the same effect as using /TERMINATE.

The /NOTERMINATE qualifier allows you to create key definitions that insert text into command lines, after prompts, or into other text that you are typing.

## **Description**

The DEFINE/KEY command enables you to assign definitions to the keys on certain terminals. The terminals include VT52s, the VT100 series, and terminals with LK201 keyboards, such as the VT200 series.

The equivalence string definition can contain different types of information. Definitions can consist of SHOW CLUSTER commands. When you define a key to insert a text string, use the /NOTERMINATE qualifier so that you can continue typing more data after the string has been inserted.

In most instances you will want to take advantage of the echo feature. The default setting is /ECHO. With the /ECHO qualifier set, the key definition is displayed on the screen each time you press the key.

## SHOW CLUSTER DEFINE/KEY

You can use the /STATE qualifier to increase the number of key definitions available on your terminal. The same key can be assigned any number of definitions as long as each definition is associated with a different state. State names can contain any alphanumeric characters, dollar signs, and underscores. Generally, you want to create a state name that is easy to remember and type and, if possible, reminds you of the types of definitions you created for that state.

### Example

```
Command> DEFINE/KEY PF3 "LOCAL_PORT"/NOTERMINATE
```

This command defines the PF3 key on the keypad to output the "LOCAL\_PORT" text string. This key could be used with the ADD key to form the ADD LOCAL\_PORT command.

## **DESELECT**

Terminates the selection of a previously selected window. When the **DESELECT** command is entered after a **MOVE** command, **SHOW CLUSTER** completes the move operation when it deselects the window. See also the **MOVE** and **SELECT** commands for related information.

### **Format**

**DESELECT**

### **Parameters**

None.

### **Qualifiers**

None.

### **Example**

```
Command> DESELECT
```

When you sent the **DESELECT** command, the previously selected window is deselected and the window is no longer highlighted.

## SHOW CLUSTER EXIT

---

### EXIT

Terminates the SHOW CLUSTER display and returns control to the DCL command level. You can also press Ctrl/Z to exit at any time.

### Format

EXIT

### Parameters

None.

### Qualifiers

None.

### Example

```
COMMAND> EXIT
```

This command terminates the SHOW CLUSTER display and returns control to the DCL command level.

## **HELP**

Provides online help information to use SHOW CLUSTER commands, parameters, and qualifiers. Press Ctrl/Z to exit.

### **Format**

HELP [keyword . . . ]

### **Parameter**

#### **keyword**

Specifies the command, parameter, or qualifier for which help information is to be displayed. If you omit the keyword, HELP displays a list of available help topics, and prompts you for a particular keyword.

### **Qualifiers**

None.

### **Examples**

1. COMMAND> HELP INITIALIZE

This command displays help information about the SHOW CLUSTER command INITIALIZE.

2. COMMAND> HELP FIELDS

This command displays help information about the valid field names that you can specify with the ADD, REMOVE, and SET commands.

# SHOW CLUSTER INITIALIZE

---

## INITIALIZE

Resets the display using the original default values for field names, class names, and field widths. It also restores any systems that were removed from the display by the REMOVE SYSTEMS command.

### Format

INITIALIZE

### Parameters

None.

### Qualifiers

None.

### Description

The INITIALIZE command resets the SHOW CLUSTER display to its default setting, consisting of the SCS window with data from the SYSTEMS class and the MEMBERS class. The report shows the node name, the software version, and the status of cluster members.

If you save a series of commands in an initialization file, using the SAVE command, SHOW CLUSTER automatically inserts an INITIALIZE command at the beginning of the file. Any command procedure that you build should start with the INITIALIZE command. In this way, you always tailor the display from a known state.

### Example

```
COMMAND> INITIALIZE
```

This command resets the current display to the default display and restores any systems that were removed from the display.



---

## **MOVE**

Moves a selected window to a specified position.

### **Format**

MOVE direction value

### **Parameters**

#### **direction**

Specifies the direction in which the window is to be moved. If you do not enter a direction for this parameter, SHOW CLUSTER prompts you for one. You must specify one of the following keywords:

UP  
DOWN  
RIGHT  
LEFT

#### **value**

Number of columns or lines the window is to be moved. You must specify a numeric value from 1 to 511. If you do not enter a number for this parameter, SHOW CLUSTER prompts you for one.

### **Qualifiers**

None.

### **Description**

The MOVE command allows you to reposition a window manually on the display screen. With one window in the SHOW CLUSTER display, you can enter MOVE commands directly. However, with multiple windows, you must select the appropriate window (SELECT window-name) before invoking MOVE commands. The MOVE command implicitly disables AUTO\_POSITIONING.

To move a selected window, either enter MOVE commands at the command prompt or use the arrow keys defined as MOVE commands. Entering the command SET FUNCTION MOVE redefines the direction keys as MOVE UP 1, MOVE DOWN 1, MOVE RIGHT 1, and MOVE LEFT 1, respectively.

When you enter a MOVE command, the window changes position by column (horizontally), or by line (vertically). An empty frame appears around the new window position. When you are satisfied with the position of the window, enter the DESELECT command, which moves the window to the new position. Entering another SELECT command before the previous window has been deselected also moves the window to its new position.

---

#### **Note**

---

If you set the function to MOVE, the arrow keys are no longer defined to perform DCL line-mode editing. Only one function can be enabled at a time, using the SET FUNCTION command.

---

## SHOW CLUSTER MOVE

### Example

```
Command> SELECT CLUSTER  
Command> MOVE RIGHT 10  
Command> DESELECT
```

The command sequence in this example moves the CLUSTER window 10 columns to the right.

## PAN

Exhibits a wide display area, a part at a time, as though being unrolled.

### Format

PAN direction value

### Parameters

#### direction

Specifies the direction in which the display is to be panned. If you do not enter a direction for this parameter, SHOW CLUSTER prompts you for one. You must specify one of the following keywords:

UP  
DOWN  
RIGHT  
LEFT

#### value

Number of columns or lines the display is to be panned. You must specify a numeric value from 1 to 511. If you do not enter a number for this parameter, SHOW CLUSTER prompts you for one.

### Qualifiers

None.

### Description

The PAN commands rotate the entire display by column (horizontally) and by line (vertically). A portion of the display that extends beyond the limits of the screen can be brought into view.

The display moves in the opposite direction from that specified by the PAN command. In other words, a PAN LEFT 10 command moves the display 10 columns to the right, similar to the effect of panning a camera over a landscape.

To pan the display, either enter PAN commands at the command prompt, or use the arrow keys defined as PAN commands. Entering the command SET FUNCTION PAN redefines the up, down, right, and left arrow keys as PAN UP 1, PAN DOWN 1, PAN RIGHT 1, and PAN LEFT 1, respectively.

---

#### Note

---

If you set the function to PAN, the arrow keys are no longer defined to perform DCL line-mode editing. Only one function can be enabled at a time, using the SET FUNCTION command.

---

## **SHOW CLUSTER PAN**

### **Example**

Command> PAN DOWN 10

This command pans the display 10 lines.

## **REFRESH**

Clears the screen, removes extraneous characters, and updates all fields. Pressing Ctrl/W has the same effect as entering REFRESH.

### **Format**

REFRESH

### **Parameters**

None.

### **Qualifiers**

None.

### **Example**

Command> REFRESH

This command clears the screen, removes extraneous characters, and updates all fields.

## SHOW CLUSTER REMOVE CIRCUITS

---

### REMOVE CIRCUITS

Removes CIRCUITS class information from the SHOW CLUSTER display.

#### Format

```
REMOVE CIRCUITS [qualifier[, . . . ]]
```

#### Parameters

None.

#### Qualifiers

##### **/TYPE=ALL**

Specifies that all types of circuits on each system be removed from the display, including formative, open, and closing circuits. If you specify the REMOVE CIRCUITS command without any qualifiers, all types of circuits are removed from the display by default.

##### **/TYPE=OPEN**

##### **/TYPE=NOOPEN**

Controls whether open circuits or nonopen circuits are removed from the display.

#### Description

The REMOVE CIRCUITS command removes CIRCUITS class information from the SHOW CLUSTER display. CIRCUITS class information includes data for all currently enabled fields in the CIRCUITS class.

For a list of valid CIRCUITS class fields, see Table 7–2.

#### Examples

1. `COMMAND> REMOVE CIRCUITS`

This command removes all currently enabled CIRCUITS class fields from the display.

2. `COMMAND> REMOVE CIRCUITS/TYPE=OPEN`

This command removes all Open circuits from the display.

## **REMOVE CLUSTER**

Removes CLUSTER class information from the SHOW CLUSTER display.

### **Format**

REMOVE CLUSTER

### **Parameters**

None.

### **Qualifiers**

None.

### **Description**

The REMOVE CLUSTER command removes CLUSTER class information from the SHOW CLUSTER display. CLUSTER class information includes data for all currently enabled fields in the CLUSTER class.

For a list of valid CLUSTER class fields, see Table 7–3.

### **Example**

```
COMMAND> REMOVE CLUSTER
```

This command removes all currently enabled CLUSTER class fields from the SHOW CLUSTER display.

# SHOW CLUSTER REMOVE CONNECTIONS

---

## REMOVE CONNECTIONS

Removes CONNECTIONS class information from the SHOW CLUSTER display.

### Format

```
REMOVE CONNECTIONS [/qualifier[, . . . ]]
```

### Parameters

None.

### Qualifiers

#### **/NAME=ALL**

Removes all connections currently displayed by SHOW CLUSTER. This qualifier allows you to clear the display before adding specific connection information with the command ADD CONNECTIONS/NAME=local-process-name.

#### **/NAME=local-process-name**

Specifies the local process name of connections that are to be removed from the display. A local process name appears in the LOC\_PROC\_NAME field; it can be up to 16 characters in length. If the local process name is abbreviated, SHOW CLUSTER removes all local process names matching the abbreviation.

#### **/TYPE=ALL**

Specifies that all types of connections on each circuit be removed from the SHOW CLUSTER display.

#### **/TYPE=OPEN**

#### **/TYPE=NOOPEN**

Controls whether connections in the open or nonopen state are removed from the SHOW CLUSTER display.

### Description

The REMOVE CONNECTIONS command removes CONNECTIONS class information from the SHOW CLUSTER display. CONNECTIONS class information includes data for all currently enabled fields in the CONNECTIONS class.

For a list of valid CONNECTIONS class fields, see Table 7–4.

### Examples

1. COMMAND> REMOVE CONNECTIONS

This command removes all currently enabled CONNECTIONS class fields from the SHOW CLUSTER display.

2. COMMAND> REMOVE CONNECTIONS/NAME=(VMS\$DISK\_CL\_DRVR,VMS\$TAPE\_CL\_DRVR)

This command removes the CONNECTIONS class fields associated with the local process names VMS\$DISK\_CL\_DRVR and VMS\$TAPE\_CL\_DRVR from the SHOW CLUSTER display.



## SHOW CLUSTER REMOVE CONNECTIONS

3. `COMMAND> REMOVE CONNECTIONS/TYPE=OPEN`

This command removes all Open connections from the SHOW CLUSTER display.

## SHOW CLUSTER REMOVE COUNTERS

---

### REMOVE COUNTERS

Removes COUNTERS class information from the SHOW CLUSTER display.

#### Format

```
REMOVE COUNTERS
```

#### Parameters

None.

#### Qualifiers

None.

#### Description

The REMOVE COUNTERS command removes COUNTERS class information from the SHOW CLUSTER display. COUNTERS class information includes data for all currently enabled fields in the COUNTERS class.

For a list of valid COUNTERS class fields, see Table 7-5.

#### Example

```
COMMAND> REMOVE COUNTERS
```

This command removes all currently enabled COUNTERS class fields from the SHOW CLUSTER display.

## **REMOVE CREDITS**

Removes CREDITS class information from the SHOW CLUSTER display.

### **Format**

REMOVE CREDITS

### **Parameters**

None.

### **Qualifiers**

None.

### **Description**

The REMOVE CREDITS command removes CREDITS class information from the SHOW CLUSTER display. CREDITS class information includes data for all currently enabled fields in the CREDITS class.

For a list of valid CREDITS class fields, see Table 7-6.

### **Example**

```
COMMAND> REMOVE CREDITS
```

This command removes all currently enabled CREDITS class fields from the SHOW CLUSTER display.

## SHOW CLUSTER REMOVE ERRORS

---

### REMOVE ERRORS

Removes ERRORS class information from the SHOW CLUSTER display.

#### Format

REMOVE ERRORS

#### Parameters

None.

#### Qualifiers

None.

#### Description

The REMOVE ERRORS command removes ERRORS class information from the SHOW CLUSTER display. ERRORS class information includes data for all currently enabled fields in the ERRORS class.

For a list of valid ERRORS class fields, see Table 7-7.

#### Example

```
COMMAND> REMOVE ERRORS
```

This command removes all currently enabled ERRORS class fields from the SHOW CLUSTER display.

## **REMOVE (Field)**

Disables the display of specific fields of SHOW CLUSTER information.

### **Format**

```
REMOVE field-name[, ... ]
```

### **Parameter**

**field-name**

Specifies one or more fields of information to be removed from the display of a particular class. If you specify more than one field name, insert a comma between each one.

For a list of valid field names, see Section 7.1.

### **Qualifiers**

None.

### **Examples**

1. `COMMAND> REMOVE SOFTWARE`

This command removes the SYSTEMS class SOFTWARE field from the display.

2. `COMMAND> REMOVE SOFTWARE,RP_TYPE,CON_STATE`

This command removes the SOFTWARE, RP\_TYPE, and CON\_STATE fields from the SHOW CLUSTER display.

## SHOW CLUSTER REMOVE LOCAL\_PORTS

---

### REMOVE LOCAL\_PORTS

Removes LOCAL\_PORTS class information from the SHOW CLUSTER display.

#### Format

```
REMOVE LOCAL_PORTS
```

#### Parameters

None.

#### Qualifiers

None.

#### Description

The REMOVE LOCAL\_PORTS command removes LOCAL\_PORTS class information.

For a list of valid LOCAL\_PORTS class fields, see Table 7–8.

#### Example

```
COMMAND> REMOVE LOCAL_PORTS
```

This command removes all currently enabled LOCAL\_PORTS class fields from the LOCAL\_PORTS display.

## **REMOVE MEMBERS**

Removes MEMBERS class information from the SHOW CLUSTER display.

### **Format**

REMOVE MEMBERS

### **Parameters**

None.

### **Qualifiers**

None.

### **Description**

The REMOVE MEMBERS command removes MEMBERS class information from the SHOW CLUSTER display. MEMBERS class information includes data for all actively participating members of the cluster.

For a list of valid MEMBERS class fields, see Table 7–9.

### **Example**

```
COMMAND> REMOVE MEMBERS
```

This command removes all currently enabled MEMBERS class fields from the SHOW CLUSTER display.

## SHOW CLUSTER REMOVE SYSTEMS

---

### REMOVE SYSTEMS

Removes SYSTEMS class information from the SHOW CLUSTER display.

#### Format

```
REMOVE SYSTEMS [/qualifier[, . . . ]]
```

#### Parameters

None.

#### Qualifiers

##### **/ID=ALL**

Removes all systems information from the SHOW CLUSTER display. The qualifier clears the display so that you can selectively add systems with the command ADD SYSTEMS/ID=system-id.

##### **/ID=system-id**

Specifies, by system identification number, systems to be removed from the SHOW CLUSTER display. The system identification number can be any system identification as displayed in the SYS\_ID field of the SYSTEMS class of the CLUSTER report.

The /ID qualifier affects all information displayed about the specified system, not just information in the SYSTEMS class display.

##### **/NODE=ALL**

Removes all systems information from the SHOW CLUSTER display. The qualifier clears the display so that you can selectively add systems with the command ADD SYSTEMS/NODE=node-name.

##### **/NODE=node-name**

Specifies, by node name, systems to be removed from the SHOW CLUSTER display. The /NODE qualifier affects all information displayed about the specified node, not just information in the SYSTEMS class display.

##### **/TYPE=ALL**

Removes all systems information from the SHOW CLUSTER display. The qualifier clears the display so that you can selectively add systems with the command ADD SYSTEMS/TYPE=hardware-type.

##### **/TYPE=hardware-type**

Specifies, by hardware type, systems to be added to the SHOW CLUSTER display. You can specify any of the types shown in the HW\_TYPE field, and you must enclose the type in quotation marks, for example: "VAX 8800". Because the quoted text may be abbreviated, it is possible, for example, to remove VAXstation II and VAXstation 2000 systems with a single command. Multiple types may be specified if enclosed in parentheses and separated by commas. Hardware types are not case sensitive.

The /TYPE qualifier affects all information displayed about the specified hardware type, not just information in the SYSTEMS class display.



# SHOW CLUSTER REMOVE SYSTEMS

## Description

The REMOVE SYSTEMS command removes SYSTEMS class information from the SHOW CLUSTER display. SYSTEMS class information includes data for all currently enabled fields in the SYSTEMS class.

For a list of valid SYSTEMS class fields, see Table 7–10.

## Examples

1. `COMMAND> REMOVE SYSTEMS`

This command removes all currently enabled SYSTEMS class fields from the SHOW CLUSTER display.

2. `COMMAND> REMOVE SYSTEMS/ID=(1976,206)`

This command removes systems with the identifier of 1976 or 206 from the SHOW CLUSTER display.

3. `COMMAND> REMOVE SYSTEMS/TYPE="VAX 8800"`

This command removes all VAX 8800 systems from the SHOW CLUSTER display.

## SHOW CLUSTER SAVE

---

### SAVE

Allows you to build a startup initialization file or a command procedure that creates the current display. You can then use the initialization file or the command procedure to restore the display at a later time.

### Format

```
SAVE [file-spec]
```

### Parameter

#### **file-spec**

Names the file specification of the command file. The file name defaults to SHOW\_CLUSTER.COM. You can edit the file because it is an ASCII file.

### Qualifiers

None.

### Description

The SAVE command allows you to build a startup initialization file or a command procedure that you can use in subsequent SHOW CLUSTER sessions. To use the SAVE command, perform the following steps:

1. Customize the display to meet your needs by using SHOW CLUSTER commands.
2. Enter the SAVE command. By default, the command procedure created is named SHOW\_CLUSTER.COM. If you want a name that is different from the default, specify the alternate name on the SAVE command line. You save a startup initialization file as an .INI file.
3. Edit the file to improve its efficiency and document it.

The file that results from the SAVE command is an ASCII file. The SAVE command inserts an INITIALIZE command as the first line of the file. In this way, the initialization file or the command procedure always starts with the default display.

The SAVE command might not enter SHOW CLUSTER commands into the file in the same order in which you entered them. You might need to edit the file and correct the sequence of commands. Also, the commands that the SAVE command builds are restricted to one record, so a particular command procedure might not be as efficient as possible. For example, the SAVE command processes ADD class, ADD class /ALL, and ADD (Field) commands separately. It does not combine an ADD class and an ADD (Field) command to produce the command ADD class, field.

Additionally, the SAVE command does not use the REMOVE (Field) command. For example, the following command sequence adds all fields in the CIRCUITS class and then removes one field from the CIRCUITS class:

```
Command> ADD CIRCUITS/ALL  
Command> REMOVE RP_TYPE
```

## SHOW CLUSTER SAVE

Instead of removing one field from a class, the SAVE command produces a file with commands that add every field in the CIRCUITS class except RP\_TYPE:

```
ADD LPORT_NAME,RPORT_NUM,RP_OWNER,NUM_CONNECTIONS,CIR_STATE  
ADD REM_STATE,CABLE_STATUS,RP_REVISION,RP_FUNCTIONS,SCS_WAITERS
```

### Example

```
Command> ADD CLUSTER  
Command> REMOVE SOFTWARE  
Command> SAVE
```

The first two commands in the command sequence customize the SHOW CLUSTER display. The third command, SAVE, creates a command file, SHOW\_CLUSTER.COM, which contains the following commands:

```
INITIALIZE  
ADD CLUSTER  
REMOVE SYSTEMS  
ADD NODE
```

# SHOW CLUSTER SCROLL

---

## SCROLL

Scrolls a window.

### Format

SCROLL direction value

### Parameters

#### direction

Direction in which a window is to be scrolled. If you do not enter a direction for this parameter, SHOW CLUSTER prompts you for one. You must specify one of the following keywords:

UP  
DOWN  
RIGHT  
LEFT

#### value

Number of fields or lines a window is to be scrolled. You must specify a numeric value from 1 to 511. If you do not enter a number for this parameter, SHOW CLUSTER prompts you for one.

### Qualifiers

None.

### Description

The SCROLL command provides a means of quickly scanning through a window by field (horizontally) and by line (vertically). You can scroll windows independently. Note, however, that if AUTO\_POSITIONING is set to ON, other windows in the display may change position as you scroll the selected window.

To scroll a window when it is the only one in the display, enter the SCROLL command. When the display has multiple windows, you must first select a window by entering the SELECT command. The selected window becomes highlighted. Enter SCROLL commands either at the command line or by pressing the arrow keys. Entering the command SET FUNCTION SCROLL redefines the up, down, right, and left arrow keys as SCROLL UP 1, SCROLL DOWN 1, SCROLL RIGHT 1, and SCROLL LEFT 1, respectively.

Use the vertical and horizontal lines of the window fields as indicators of the current position of the display. Note that the window headings remain stationary as lines of data are scrolled vertically.

---

#### Note

---

If you set the function to SCROLL, the arrow keys are no longer defined to perform DCL line-mode editing. Only one function can be enabled at a time, using the SET FUNCTION command.

---

**Example**

```
Command> SELECT SCS  
Command> SCROLL UP 10  
Command> DESELECT
```

This command sequence scrolls the SCS window up 10 lines.

## SHOW CLUSTER SELECT

---

### SELECT

Designates which window to scroll, move, or pan.

### Format

SELECT [window-name]

### Parameter

#### **window-name**

The name of the selected window. You can specify one of the following window names: SCS, LOCAL\_PORTS, or CLUSTER.

### Qualifiers

None.

### Description

When the SHOW CLUSTER display contains more than one window, you must indicate which window you want to work with—either by entering a SELECT command at the command line prompt or by pressing the SELECT key on the default keypad.

If you press the SELECT key on the keypad or enter the SELECT command without specifying the window name, SHOW CLUSTER selects a window for you. Pressing the SELECT key repeatedly cycles through the windows in the order in which they were initially added to the screen. Each subsequent SELECT command terminates the previous one. The currently selected window becomes highlighted. When the last window in the cycle has been selected, pressing the SELECT key another time begins the cycle again.

Use the SELECT command to identify a window to be moved, panned, or scrolled. Once the display is correct, terminate the window operation by entering a DESELECT command or by selecting another window. For more information, see the SET FUNCTION, SCROLL, PAN, and MOVE commands.

### Example

```
Command> SELECT LOCAL_PORTS
```

This command selects the LOCAL\_PORTS window. You can then perform a MOVE or SCROLL operation on the selected window.

---

## **SET AUTO\_POSITIONING**

Enables or disables the automatic positioning of windows within a display.

### **Format**

SET AUTO\_POSITIONING keyword

### **Parameter**

#### **keyword**

Specifies whether windows are automatically positioned in a display. By default, SHOW CLUSTER operates with AUTO\_POSITIONING enabled. Valid keywords are as follows:

ON  
OFF

### **Qualifiers**

None.

### **Description**

By default, SHOW CLUSTER automatically positions windows based on their sizes and the order in which they were originally added to the display. With AUTO\_POSITIONING set to ON, windows do not overlap, but they may extend partially or fully beyond the physical limits of the terminal screen. Setting AUTO\_POSITIONING to OFF allows you to position the window manually within the display.

Entering a MOVE command implicitly disables AUTO\_POSITIONING. When you use MOVE commands to position a selected window, the windows are allowed to overlap.

Setting AUTO\_POSITION to ON reestablishes the previous positions of windows.

### **Example**

```
Command> SET AUTO_POSITIONING OFF  
Command> ADD LOCAL_PORTS  
Command> SELECT SCS  
Command> MOVE DOWN 8  
Command> DESELECT
```

This command sequence disables AUTO\_POSITIONING to add the LOCAL\_PORTS window at the top of the screen. The following commands move the SCS window below the LOCAL\_PORTS window, where it is in full view.

## SHOW CLUSTER SET (Field)

---

### SET (Field)

Modifies the characteristics of particular fields within the display.

### Format

SET field-name /qualifier[, . . . ]

### Parameter

#### **field-name**

Specifies the name of the field to be modified in the display. For a list of field names, see Section 7.1.

### Qualifiers

#### **/WIDTH=field-width**

Specifies the number of columns used to display the specified field. This qualifier shrinks the display to allow room for more fields or expands it to make it easier to read.

Minimum, maximum, and default values for field widths are set up internally. If you specify a field width of 0, the field is set to its minimum width. If you specify a field width that is larger than the internal maximum width, the field is set to its maximum width.

---

#### **Note**

---

If the field width is too narrow to display a particular numeric field, asterisks are displayed in place of the data. If the width is too narrow to display a character-string field, the character string is truncated on the “right”.

---

#### **/FORMAT=radix**

Specifies the display format used to display the specified field. You can specify either of the following radix values:

DECIMAL for decimal format

HEXADECIMAL for hexadecimal format

A hexadecimal display for a field uses fewer columns than a decimal display.

The hardware version field (HW\_VERSION) is always displayed in 24 hexadecimal digits.

### Example

```
COMMAND> SET SYSID/FORMAT=HEXADECIMAL
```

The SET command in this example changes the format of the SYSID field to a hexadecimal display.



---

## SET FUNCTION

Enables one of the following SHOW CLUSTER functions: EDIT, MOVE, PAN, or SCROLL.

### Format

SET FUNCTION function-name

### Parameter

#### function-name

Specifies the SHOW CLUSTER function to be enabled. By default, the EDIT function is enabled. Functions include the following ones:

EDIT  
MOVE  
PAN  
SCROLL

### Qualifiers

None.

### Description

The SET FUNCTION command redefines the arrow keys to perform the specified function. By default, the function is set to EDIT, which allows you to use the arrow keys to recall a previously entered command or perform DCL line-mode editing at the command prompt. (For more information about DCL line-mode editing, see the *OpenVMS User's Manual*.)

To enable one of the SHOW CLUSTER functions, either enter the specific SET FUNCTION command at the command prompt, or press the appropriate SET FUNCTION key on the keypad. Only one function can be enabled at a time.

---

#### Note

---

Setting the function to MOVE implicitly disables AUTO\_POSITIONING.

Also, once you use the SET FUNCTION command, the arrow keys are no longer defined to perform DCL line-mode editing. Only one function can be enabled at a time using the SET FUNCTION command.

---

### Example

```
Command> SET FUNCTION MOVE
```

This command redefines the arrow keys to automatically move a selected window 1 space in any direction. For example, the up, down, right, and left arrow keys are redefined as MOVE UP 1, MOVE DOWN 1, MOVE RIGHT 1, and MOVE LEFT 1, respectively. Note that you must use the DESELECT command to complete the MOVE function.

## SHOW CLUSTER SET INTERVAL

---

### SET INTERVAL

Changes the interval time between display updates. The interval time is the amount of time that display information remains on the screen before it is updated. By default, the display updates every 15 seconds, unless you use the /INTERVAL qualifier on the SHOW CLUSTER command. If you use the /INTERVAL qualifier, the time specified becomes the default.

#### Format

SET INTERVAL=seconds

#### Parameter

**seconds**

The number of seconds between display updates.

#### Qualifiers

None.

#### Example

```
COMMAND> SET INTERVAL=5
```

This command changes the display interval time to 5 seconds.

## **SET SCREEN**

Sets the terminal to a display of up to 511 columns. This command can be used only on HP-compatible terminals.

### **Format**

SET SCREEN=screen-width

### **Parameter**

#### **screen-width**

Specifies the width of the screen display. Depending on terminal type, you can specify a value up to 511.

### **Qualifiers**

None.

### **Description**

The SET SCREEN command redefines the width of the display to the number of columns that you specify.

If you use an initialization file in noncontinuous mode and the initialization file contains a SET SCREEN command that changes the screen size, SHOW CLUSTER sets the screen to the specified size for one update interval and then resets the screen to the original size.

### **Example**

```
COMMAND> SET SCREEN=132
```

This command sets the screen width to 132 columns.

## SHOW CLUSTER WRITE

---

### WRITE

Outputs the current display to a file that can be printed on a hardcopy device.

### Format

WRITE [file-spec]

### Parameter

#### **file-spec**

Names the file specification of the printable output file. By default, the output file name is SHOW\_CLUSTER.LIS.

### Qualifiers

#### **/ALL**

Indicates that the output file should contain a display consisting of all classes and all fields. Because SHOW CLUSTER may not currently have the information necessary to display all the possible fields when you specify the /ALL qualifier, a display update occurs prior to the output of the file. As a result, the output file may differ from the display on the screen at the time the command was entered. The screen is updated along with the file output, so subsequently they are the same.

When reporting a cluster-related problem to HP, use the /ALL qualifier to produce an output or hardcopy file.

### Example

Command> WRITE/ALL

This command creates a file, SHOW\_CLUSTER.LIS, which contains all possible SHOW CLUSTER fields. SHOW\_CLUSTER.LIS can be printed on a hardcopy device.

---

## System Generation Utility

### 8.1 SYSGEN Description

The System Generation utility (SYSGEN) is a system management tool used to tailor a system for a specific hardware and software configuration. Use SYSGEN commands to manipulate specific parts of the operating system, as follows:

- System parameters: DISABLE, ENABLE, SET, SHOW, USE, and WRITE.  
A complete description of devices and device drivers is in the *OpenVMS VAX Device Support Manual*. (This manual has been archived.)
- System files: CREATE and INSTALL.
- Startup command procedure: SET/STARTUP and SHOW/STARTUP.
- Multiport memory: SHARE and SHARE/INITIALIZE.

You can use a subset of the SYSGEN commands to invoke the SYSBOOT facility during bootstrap operations. For more information, see the installation instructions for your processor and the *HP OpenVMS System Manager's Manual*.

#### 8.1.1 Specifying Values for SYSGEN Qualifiers and Parameters

Normally, you specify values as an integer, keyword, or file specification. For parameters, integer values must be within the defined maximum and minimum values for the parameter unless the SYSGEN command DISABLE CHECKS was specified.

You can specify values for certain SYSGEN qualifiers and parameters in hexadecimal or octal radices and for others as an ASCII string. To specify a value in octal or hexadecimal, precede the value with %O or %X, respectively. To specify a value in ASCII, enclose the value string in quotation marks (" ").

Appendix D lists system parameters.

#### 8.1.2 Using Active and Current Parameter Values

System parameter values can be either active or current:

- An **active parameter** is one whose value is active when the system is running. Active parameters that can be changed on a running system are categorized as dynamic parameters. (See Appendix D.)
- A **current parameter** is one whose value is stored on disk (SYS\$SYSTEM:ALPHAVMSSYS.PAR on Alpha systems or SYS\$SYSTEM:IA64VMSSYS.PAR on Integrity server systems) and used for booting the system. Current parameters become active parameters when the system boots.

## **SYSGEN**

### **8.1 SYSGEN Description**

Modifying active parameters with SYSGEN has no effect on the values of the stored current parameters; you change the values of these parameters only while the system is running. In a subsequent bootstrap of the system, the old values of the current parameters are established as the active parameters. To change the values of the current parameters on disk, use the SYSGEN command `WRITE CURRENT`. To change the values of any active parameter that is not in the dynamic category, enter the `WRITE CURRENT` command and reboot the system.

### **8.2 SYSGEN Usage Summary**

The System Generation utility (SYSGEN) is a system management tool that performs certain privileged system configuration functions. With SYSGEN, you can create and modify system parameters, load device drivers, and create additional page and swap files.

#### **Format**

`RUN SYS$SYSTEM:SYSGEN`

#### **Parameters**

None.

#### **Description**

To invoke SYSGEN, enter `RUN SYS$SYSTEM:SYSGEN` at the DCL command prompt. At the `SYSGEN>` prompt, enter any of the SYSGEN commands described in the following section. These commands follow the standard rules of grammar as specified in the *HP OpenVMS DCL Dictionary*.

To exit from SYSGEN, enter the `EXIT` command at the `SYSGEN>` prompt or press `Ctrl/Z`. You can direct output from a SYSGEN session to an output file using the `SET/OUTPUT` command. By default, output is written to `SYS$OUTPUT`.

---

#### **Note**

---

HP recommends the use of the `AUTOGEN` command procedure when modifying system parameters, loading device drivers, or creating additional page and swap files.

---

### **8.3 SYSGEN Commands**

This section describes and provides examples of SYSGEN commands.

---

## CREATE

Creates a file that can be used as a page, swap, or dump file. Normally, this command is used indirectly by executing the command procedure SYS\$UPDATE:SWAPFILES.

### Format

CREATE file-spec

### Parameter

**file-spec**

The name of the file to be created.

### Qualifiers

**/CONTIGUOUS  
/NOCONTIGUOUS**

Specifies that the created file is either to be contiguous (/CONTIGUOUS) or contiguous-best-try (/NOCONTIGUOUS). The Primitive File System used during OpenVMS bootstrap limits the page, swap, and dump files to one file header. Because of this restriction, OpenVMS cannot be reliably bootstrapped from a bound volume set and is not supported on a bound volume set.

**/SIZE=block-count**

Specifies the size in blocks of the file to be created.

### Example

```
SYSGEN> CREATE DISK$PAGE:[NODE1]PAGEFILE.SYS /SIZE=200000
```

This command creates a file called PAGEFILE.SYS on the disk DISK\$PAGE: in directory [NODE1]. This file is created as a contiguous-best-try file, which is the default. SYSGEN creates the file with 200,000 blocks, or allocates as many blocks on the disk as it can and displays a message warning that the file does not have the full allocation specified with the CREATE command.

The file will not be used for paging or swapping until you use the SYSGEN command INSTALL specifying the file and how it is to be used.

# **SYSGEN DEINSTALL**

---

## **DEINSTALL**

Deinstalls a page or swap file. Requires CMKRNL privilege. Any file installed with the SYSGEN command INSTALL can be deinstalled.

If the specified file is being actively used by processes, this command simply marks the file as "deinstall pending". This prevents any new assignments or reservations to the file from occurring. When all outstanding references to the file have been removed, the deinstallation will complete.

Files in the deinstall pending state are identified in the DCL command SHOW MEMORY/FILES display.

### **Format**

```
DEINSTALL file-spec  
DEINSTALL/ALL  
DEINSTALL/INDEX=n
```

### **Parameter**

#### **file-spec**

Specifies the name of a file that is to be deinstalled as a page or swap file.

### **Qualifiers**

#### **/PAGEFILE**

Specifies that the file to be deinstalled is a page file.

#### **/SWAPFILE**

Specifies that the file to be deinstalled is a swap file.

#### **/ALL**

Deinstalls all page and swap files currently installed on the system. This command is most useful during an orderly system shutdown procedure where all disk volumes are being dismounted.

No other parameters or qualifiers are allowed.

#### **/INDEX=n**

Deinstalls a page or swap file specified by page file index. The page file index is presented in the DCL command SHOW MEMORY/FILES/FULL display as "Page File Number."

No other parameters or qualifiers are allowed.

### **Example**

```
SYSGEN> DEINSTALL DRA1:[SYSEXE]PAGEFILE.SYS /PAGEFILE
```



---

**DISABLE**

Inhibits the checking that SYSGEN performs on parameter values. By default, range checking is enabled.

**Format**

DISABLE CHECKS

**Parameters**

None.

**Qualifiers**

None.

## **SYSGEN ENABLE**

---

### **ENABLE**

Requests that SYSGEN ensure that parameter values changed using the SET command remain in the allowable range. By default, the range checking is enabled.

### **Format**

ENABLE CHECKS

### **Parameters**

None.

### **Qualifiers**

None.

## **INSTALL**

Installs an additional page or swap file. Requires CMKRNL privilege.

### **Format**

INSTALL file-spec

### **Parameter**

#### **file-spec**

Specifies the name of a file that is to be installed as a page or swap file. This file can reside on any volume that is mounted /SYSTEM. The file should be contiguous for best performance.

### **Qualifiers**

#### **/PAGEFILE**

Specifies that the file is to be installed as an additional page file. This page file will augment any page file installed during the boot process.

#### **/SWAPFILE**

Specifies that the file is to be installed as an additional swap file. This swap file will augment any swap file installed during the boot process.

### **Example**

```
SYSGEN> INSTALL DRA1:[SYSEXE]PAGEFILE.SYS /PAGEFILE
```

# SYSGEN SET

---

## SET

Assigns a value to a system parameter in the SYSGEN work area.

This command does not modify parameter files, the current system parameter file on disk, or the active system; for information about performing these modifications, see the WRITE command.

## Format

SET parameter-name value

## Parameters

### parameter-name

Specifies the name of a system parameter. If you enter a period (.), it is interpreted as a request for the system parameter specified in the last SET or SHOW command. See the description of the SHOW parameter-name command for an example of the use of the period in place of a parameter name.

### value

Usually specifies an integer or the keyword DEFAULT. Integer values must be within the defined minimum and maximum values for the parameter unless the SYSGEN command DISABLE CHECKS was specified.

The keyword DEFAULT specifies the default value for the parameter. You can display the maximum, minimum, and default values for any parameter with the SYSGEN command SHOW parameter-name.

You can specify values for certain SYSGEN parameters in hexadecimal or octal radices and for others as an ASCII string. To specify a value in octal or hexadecimal, precede the value with %O or %X, respectively. To specify a value in ASCII, enclose the value string in quotation marks (" ").

## Qualifiers

None.

## Examples

1. SYSGEN> SET PFCDEFAULT 20

This command assigns a value of 20 to the PFCDEFAULT parameter.

2. SYSGEN> SET GBLSECTIONS DEFAULT

This command assigns the default value (40) to the GBLSECTIONS parameter.

## **SET/OUTPUT**

Establishes a file to be used for output during the session. By default the output is written to SYS\$OUTPUT, but you can use SET/OUTPUT to designate a disk file.

At any time you can direct the output back to SYS\$OUTPUT by using the SET/OUTPUT=SYS\$OUTPUT command.

### **Format**

SET/OUTPUT[=] file-spec

### **Parameter**

#### **file-spec**

The name of the output file. The default file type is .LIS. The equal sign (=) is optional.

### **Example**

```
SYSGEN> SET/OUTPUT=PARAMS.LIS
SYSGEN> SHOW/ALL
SYSGEN> SHOW/SPECIAL
SYSGEN> EXIT
```

In this example, output is directed to the file PARAMS.LIS to capture a complete list of all the system parameters (including the SPECIAL parameters reserved for HP use) and their values.

## **SYSGEN SET/STARTUP**

---

### **SET/STARTUP**

Names the site-independent startup command procedure to be associated with a parameter file for subsequent bootstrap operations.

#### **Format**

SET/STARTUP file-spec

#### **Parameter**

##### **file-spec**

The file specification of a startup command procedure on the system disk (maximum of 31 characters). The initial site-independent startup command procedure (as named in the software distribution kit) is SYS\$SYSTEM:STARTUP.COM.

#### **Example**

```
SYSGEN> SET/STARTUP SYS$SYSTEM:XSTARTUP.COM
```

This command assigns SYS\$SYSTEM:XSTARTUP.COM as the current site-independent startup command procedure.

---

**SHOW**

Displays the values of system parameters in the SYSGEN work area, plus the default, minimum, and maximum values of the parameters and their units of measure.

**Format**

SHOW parameter-name

**Parameter****parameter-name**

Specifies the name of a system parameter. If you enter a period (.), it is interpreted as a request for the system parameter specified in the last SET parameter-name or SHOW parameter-name command.

Beginning in OpenVMS Version 8.2, specifies OBSOLETE in the Units column for any specified parameter that is obsolete.

**Qualifiers****/ACP**

Specifies that all ACP parameter values are displayed.

**/ALL**

Specifies that all parameter values other than SPECIAL parameter values are displayed.

**/BI**

Specifies that device addresses that are currently mapped in the I/O space for the VAXBI bus are displayed.

**/CLUSTER**

Specifies that all CLUSTER parameter values are displayed.

**/DYNAMIC**

Specifies that all DYNAMIC parameter values are displayed.

**/GEN**

Specifies that all GEN parameter values are displayed.

**/HEX**

Specifies that the values of parameters be displayed in hexadecimal representation. Specify the /HEX system parameter name or the parameter type. If you specify the /HEX qualifier with the /NAMES qualifier, /HEX is ignored.

**/JOB**

Specifies that all JOB parameter values are displayed.

**/LGI**

Specifies that all LGI parameter values are displayed.

**/MAJOR**

Specifies that all MAJOR parameter values are displayed.

# **SYSGEN SHOW**

## **/MULTIPROCESSING**

Specifies that all MULTIPROCESSING parameters are displayed.

## **/NAMES**

Specifies that the names of all parameters are displayed.

## **/OBSOLETE**

Specifies that the names of all obsolete parameters are displayed.

## **/PQL**

Specifies that all PQL parameter values are displayed.

## **/RMS**

Specifies that all RMS parameter values are displayed.

## **/SCS**

Specifies that all SCS parameter values are displayed.

## **/SPECIAL**

Specifies that all parameter values reserved for HP use are displayed.

## **/STARTUP**

Specifies that the name of the current site-independent startup command procedure is displayed.

## **/SYS**

Specifies that all SYS parameter values are displayed.

## **/TTY**

Specifies that all terminal parameter values are displayed.

## **/XMI[=BIindex]**

Specifies that device addresses that are currently mapped in the I/O space for the XMI bus are displayed. The /XMI qualifier also displays node and nexus numbers and generic names of all processors, adapters, VAXBI adapters, memory controllers, and interconnection devices such as the NI.

Use of the SHOW/XMI=BIindex command requires the CMEXEC privilege.

## **Description**

Parameter values are displayed in decimal unless the /HEX qualifier is specified. Note that ASCII values are displayed in ASCII by default.

When parameter names are abbreviated on a VAX platform, the first parameter matching the abbreviation is selected for display. No ambiguity checks are made. On an Alpha or Integrity servers platform, all parameters whose names match the abbreviation are printed.

For example, a specification of SHOW GBL on a VAX system displays only the GBLSECTIONS parameter. To display the GBLPAGFIL parameter, you must specify SHOW GBLPAGF (to avoid further ambiguity with the GBLPAGES parameter). On an Alpha or Integrity servers, the same SHOW GBL command displays GBLSECTIONS, GBLPAGES, and GBLPAGFIL.

You can enter a period (.) to indicate that you want to work with the system parameter that was specified in the last SET parameter-name or SHOW parameter-name command.



## Examples

1. SYSGEN> SHOW GBLSECTIONS

| Parameter Name | Current | Default | Minimum | Maximum | Unit     | Dynamic |
|----------------|---------|---------|---------|---------|----------|---------|
| GBLSECTIONS    | 100     | 40      | 20      | -1      | Sections |         |

SYSGEN> SET . 110

SYSGEN> SHOW .

| Parameter Name | Current | Default | Minimum | Maximum | Unit     | Dynamic |
|----------------|---------|---------|---------|---------|----------|---------|
| GBLSECTIONS    | 110     | 40      | 20      | -1      | Sections |         |

In this example, the user first displays the values of the GBLSECTIONS parameter and then refers to the parameter with a period to set its current value to 110. The next SHOW command also uses the period notation to obtain confirmation that the change occurred.

2. SYSGEN> SHOW/ACP

On a VAX system, the command in this example produces the following output:

Parameters in use: Active

| Parameter Name | Current | Default | Minimum | Maximum | Unit        | Dynamic |
|----------------|---------|---------|---------|---------|-------------|---------|
| ACP_MULTIPLE   | 0       | 1       | 0       | 1       | Boolean     | D       |
| ACP_SHARE      | 1       | 1       | 0       | 1       | Boolean     |         |
| ACP_MAPCACHE   | 52      | 8       | 1       | -1      | Pages       | D       |
| ACP_HDRCACHE   | 138     | 128     | 2       | -1      | Pages       | D       |
| ACP_DIRCACHE   | 138     | 80      | 2       | -1      | Pages       | D       |
| ACP_DINDXCACHE | 37      | 25      | 2       | -1      | Pages       | D       |
| ACP_WORKSET    | 0       | 0       | 0       | -1      | Pages       | D       |
| ACP_FIDCACHE   | 64      | 64      | 0       | -1      | File-Ids    | D       |
| ACP_EXTCACHE   | 64      | 64      | 0       | -1      | Extents     | D       |
| ACP_EXTLIMIT   | 300     | 300     | 0       | 1000    | Percent/10  | D       |
| ACP_QUOCACHE   | 130     | 64      | 0       | -1      | Users       | D       |
| ACP_SYSACC     | 4       | 8       | 0       | -1      | Directories | D       |
| ACP_MAXREAD    | 32      | 32      | 1       | 64      | Blocks      | D       |
| ACP_WINDOW     | 7       | 7       | 1       | -1      | Pointers    | D       |
| ACP_WRITEBACK  | 1       | 1       | 0       | 1       | Boolean     | D       |
| ACP_DATACHECK  | 2       | 2       | 0       | 3       | Bit-mask    | D       |
| ACP_BASEPRIO   | 8       | 8       | 4       | 31      | Priority    | D       |
| ACP_SWAPFLGS   | 14      | 15      | 0       | 15      | Bit-mask    | D       |
| ACP_XQP_RES    | 1       | 1       | 0       | 1       | Boolean     |         |
| ACP_REBLDSYSD  | 0       | 1       | 0       | 1       | Boolean     |         |

3. SYSGEN> SHOW/ACP/HEX

The command in this example produces a hexadecimal display of the values of the ACP system parameters, as follows:

# SYSGEN SHOW

Parameters in use: Active

| Parameter Name | Current  | Default  | Minimum  | Maximum  | Unit        | Dynamic |
|----------------|----------|----------|----------|----------|-------------|---------|
| ACP_MULTIPLE   | 00000000 | 00000001 | 00000000 | 00000001 | Boolean     | D       |
| ACP_SHARE      | 00000001 | 00000001 | 00000000 | 00000001 | Boolean     |         |
| ACP_MAPCACHE   | 00000034 | 00000008 | 00000001 | FFFFFFFF | Pages       | D       |
| ACP_HDRCACHE   | 0000008A | 00000080 | 00000002 | FFFFFFFF | Pages       | D       |
| ACP_DIRCACHE   | 0000008A | 00000050 | 00000002 | FFFFFFFF | Pages       | D       |
| ACP_DNDXCACHE  | 00000025 | 00000019 | 00000002 | FFFFFFFF | Pages       | D       |
| ACP_WORKSET    | 00000000 | 00000000 | 00000000 | FFFFFFFF | Pages       | D       |
| ACP_FIDCACHE   | 00000040 | 00000040 | 00000000 | FFFFFFFF | File-Ids    | D       |
| ACP_EXTCACHE   | 00000040 | 00000040 | 00000000 | FFFFFFFF | Extents     | D       |
| ACP_EXTLIMIT   | 0000012C | 0000012C | 00000000 | 000003E8 | Percent/10  | D       |
| ACP_QUOCACHE   | 00000082 | 00000040 | 00000000 | FFFFFFFF | Users       | D       |
| ACP_SYSACC     | 00000004 | 00000008 | 00000000 | FFFFFFFF | Directories | D       |
| ACP_MAXREAD    | 00000020 | 00000020 | 00000001 | 00000040 | Blocks      | D       |
| ACP_WINDOW     | 00000007 | 00000007 | 00000001 | FFFFFFFF | Pointers    | D       |
| ACP_WRITEBACK  | 00000001 | 00000001 | 00000000 | 00000001 | Boolean     | D       |
| ACP_DATACHECK  | 00000002 | 00000002 | 00000000 | 00000003 | Bit-mask    | D       |
| ACP_BASEPRIO   | 00000008 | 00000008 | 00000004 | 0000001F | Priority    | D       |
| ACP_SWAPFLGS   | 0000000E | 0000000F | 00000000 | 0000000F | Bit-mask    | D       |
| ACP_XQP RES    | 00000001 | 00000001 | 00000000 | 00000001 | Boolean     |         |
| ACP_REBLDSYSD  | 00000000 | 00000001 | 00000000 | 00000001 | Boolean     |         |

#### 4. SYSGEN> SHOW/PQL

On an Alpha or Integrity server, the command in this example produces output similar to the following:

Parameters in use: Active

| Parameter Name | Current | Default | Min. | Max. | Unit      | Dynamic |
|----------------|---------|---------|------|------|-----------|---------|
| PQL_DASTLM     | 24      | 24      | -1   | -1   | Ast       | D       |
| PQL_MASTLM     | 4       | 4       | -1   | -1   | Ast       | D       |
| PQL_DBIOLM     | 32      | 32      | -1   | -1   | I/O       | D       |
| PQL_MBIOLM     | 4       | 4       | -1   | -1   | I/O       | D       |
| PQL_DBYTLM     | 65536   | 65536   | -1   | -1   | Bytes     | D       |
| PQL_MBYTLM     | 1024    | 1024    | -1   | -1   | Bytes     | D       |
| PQL_DCPULM     | 0       | 0       | -1   | -1   | 10Ms      | D       |
| PQL_MCPULM     | 0       | 0       | -1   | -1   | 10Ms      | D       |
| PQL_DDIOLM     | 32      | 32      | -1   | -1   | I/O       | D       |
| PQL_MDIOLM     | 4       | 4       | -1   | -1   | I/O       | D       |
| PQL_DFILLM     | 128     | 128     | -1   | -1   | Files     | D       |
| PQL_MFILLM     | 2       | 2       | -1   | -1   | Files     | D       |
| PQL_DPGFLQUOTA | 65536   | 65536   | -1   | -1   | Pagelets  | D       |
| internal value | 4096    | 4096    | 0    | -1   | Pages     | D       |
| PQL_MPGFLQUOTA | 2048    | 2048    | -1   | -1   | Pagelets  | D       |
| internal value | 128     | 128     | 128  | -1   | Pages     | D       |
| PQL DPRCLM     | 32      | 32      | -1   | -1   | Processes | D       |
| PQL_MPRCLM     | 0       | 0       | -1   | -1   | Processes | D       |
| PQL_DTQELM     | 16      | 16      | -1   | -1   | Timers    | D       |
| PQL_MTQELM     | 0       | 0       | -1   | -1   | Timers    | D       |
| PQL_DWSDEFAULT | 2000    | 2000    | -1   | -1   | Pagelets  |         |
| internal value | 125     | 125     | 0    | -1   | Pages     |         |
| PQL_MWSDEFAULT | 2000    | 2000    | -1   | -1   | Pagelets  |         |
| internal value | 125     | 125     | 125  | -1   | Pages     |         |
| PQL_DWSQUOTA   | 4000    | 4000    | -1   | -1   | Pagelets  | D       |
| internal value | 250     | 250     | 0    | -1   | Pages     | D       |
| PQL_MWSQUOTA   | 4000    | 4000    | -1   | -1   | Pagelets  | D       |
| internal value | 250     | 250     | 250  | -1   | Pages     | D       |
| PQL_DWSEXTENT  | 12000   | 12000   | -1   | -1   | Pagelets  | D       |
| internal value | 750     | 750     | 0    | -1   | Pages     | D       |
| PQL_MWSEXTENT  | 4000    | 4000    | -1   | -1   | Pagelets  | D       |
| internal value | 250     | 250     | 250  | -1   | Pages     | D       |
| PQL_DENQLM     | 64      | 64      | -1   | -1   | Locks     | D       |
| PQL_MENQLM     | 4       | 4       | -1   | -1   | Locks     | D       |

**SYSGEN  
SHOW**

|              |      |      |    |          |   |
|--------------|------|------|----|----------|---|
| PQL_DJTQUOTA | 1024 | 1024 | -1 | -1 Bytes | D |
| PQL_MJTQUOTA | 0    | 0    | -1 | -1 Bytes | D |

## **SYSGEN SHOW/STARTUP**

---

### **SHOW/STARTUP**

Displays the name of the current site-independent startup command procedure.

#### **Format**

SHOW/STARTUP

#### **Parameters**

None.

#### **Qualifiers**

None.

#### **Example**

```
SYSGEN> SHOW/STARTUP  
Startup command file = SYS$SYSTEM:STARTUP.COM
```

This command displays the name of the site-independent startup command procedure.

## **TERMINAL**

Modifies the Ctrl/C, Ctrl/O, Ctrl/Y, and Ctrl/Z echo strings on a systemwide basis.

### **Format**

TERMINAL/ECHO

### **Parameters**

None.

### **Qualifiers**

None.

### **Description**

Before entering the TERMINAL command, edit the file SYSGTTSTR.MSG in SYS\$EXAMPLES. The file contains detailed instructions for the editing procedure.

When you enter the TERMINAL command after editing the file, the modifications you have specified are carried out.

## **SYSGEN USE**

---

### **USE**

Initializes the SYSGEN work area with system parameter values and the name of the site-independent startup command procedure, overwriting existing values. The initial values of the SYSGEN work area when the utility is invoked are the active values.

Specify the source for both the parameter values and the procedure name. They can be retrieved from a parameter file, the current system parameter file on disk, the active system in memory, or the default list.

### **Format**

USE file-spec

### **Parameters**

#### **file-spec**

The file specification of a system parameter file from which data is to be retrieved. You can use the SYSGEN command WRITE to create the parameter file. The default file type is .PAR.

In place of a file specification, you can specify one of the following keywords:

#### **CURRENT**

Specifies that source information is to be retrieved from the current system parameter file on disk.

On Alpha systems, the system parameter file is  
SYS\$SYSTEM:ALPHAVMSSYS.PAR.

On Integrity servers, the system parameter file is  
SYS\$SYSTEM:IA64VMSSYS.PAR.

#### **ACTIVE**

Specifies that source information is to be retrieved from the active system in memory.

#### **DEFAULT**

Specifies that source information is to be retrieved from the default list. The USE DEFAULT command initializes the SYSGEN work area with parameter values that are built into SYSGEN; these values allow the operating system to boot on any standard configuration.

To avoid starting all layered products on a system that is not tuned for them, possibly causing the system to hang, set the STARTUP\_P1 system parameter as follows:

```
SYSGEN> SET STARTUP_P1 "MIN"
```

### **Qualifiers**

None.

## Examples

1. SYSGEN> USE SYS\$SYSTEM:SPECIAL

This command uses the existing parameter file SYS\$SYSTEM:SPECIAL.PAR.

2. SYSGEN> USE DEFAULT

```
SYSGEN> SET STARTUP_P1 "MIN"
```

The first command initializes the SYSGEN work area with default parameter values. The second command sets the STARTUP\_P1 system parameter to "minimum."

# SYSGEN WRITE

---

## WRITE

Writes the system parameter values and the name of the site-independent startup command procedure from the SYSGEN work area to a parameter file, the current system parameter file on disk, or the active system in memory.

## Format

WRITE file-spec

## Parameters

### file-spec

The file specification of a new parameter file to be created. The default file type is .PAR.

In place of a file specification, you can specify one of the following keywords:

### CURRENT

Specifies that source information is to be written to the current system parameter file on disk.

On Alpha systems, the system parameter file is  
SYS\$SYSTEM:ALPHAVMSSYS.PAR.

On Integrity servers, the system parameter file is  
SYS\$SYSTEM:IA64VMSSYS.PAR.

Use of the WRITE CURRENT command requires the SYSPRV privilege.

### ACTIVE

Specifies that source information is to be written to the active system in memory. (Only the dynamic parameter values are written to the active system.)

Use of the WRITE ACTIVE command requires the CMKRNL privilege.

## Qualifiers

None.

## Description

On VAX systems, the implementation of security auditing within SYSGEN has altered the reporting of modifications to the system parameter file VAXVMSSYS.PAR. System managers can receive notification of a change to the file by setting up an access control list (ACL) on the file to signal such an event, as in the following example:

```
$ SET SECURITY/ACL=(ALARM=SECURITY,ACCESS=WRITE+FAILURE+SUCCESS)-  
_ $ SYS$SYSTEM:VAXVMSSYS.PAR
```

For more information about setting ACLs, see the *OpenVMS User's Manual* and the *HP OpenVMS Guide to System Security*.



On Alpha and Integrity servers, both the WRITE ACTIVE and WRITE CURRENT commands send a message to OPCOM and log the event.

---

**Note**

---

Prior to Version 7.3-2, enabling SYSGEN audits or alarms did not provided audits or alarms with information about the parameters being modified. Beginning with Version 7.3-2, audits or alarms provide a list of the changed parameters along with their old and new values.

---

**Examples**

1. SYSGEN> WRITE SYS\$SYSTEM:SPECIAL

This command creates a new parameter specification file, SYS\$SYSTEM:SPECIAL.PAR.

2. SYSGEN> WRITE CURRENT

On Alpha systems, this command modifies the current system parameter file on disk, ALPHAVMSSYS.PAR.

On Integrity servers, this command modifies the current system parameter file on disk, IA64VMSSYS.PAR.



---

## System Management Utility

### 9.1 SYSMAN Description

The System Management utility (SYSMAN) centralizes the management of nodes and cluster environments. Rather than logging in to individual nodes and repeating a set of management tasks, SYSMAN enables you to define your management environment to be a particular node, a group of nodes, or a cluster environment. With a management environment defined, you can perform system management tasks from your local node. SYSMAN executes these tasks on all nodes in the target environment.

Managing a system with SYSMAN is similar to the traditional management of an individual system because SYSMAN uses many of the same software tools. It can process most DCL commands, such as MOUNT, DEFINE, INITIALIZE, SET, and SHOW. It can also execute many OpenVMS system management utilities and command procedures, such as AUTHORIZE, AUTOGEN, and INSTALL.

SYSMAN also contains system management tools that let you perform the following tasks:

- Set disk quotas using DISKQUOTA commands.
- Load and unload licenses using LICENSE commands.
- Associate a terminal or port with a user name using the automatic login facility (ALF) commands.
- Modify or display System Generation utility (SYSGEN) parameters using PARAMETERS commands.
- Build site-specific startup procedures using STARTUP commands, which display or modify startup components of the OpenVMS operating system, site-specific programs, and layered products.
- Modify or display OpenVMS Cluster parameters using CONFIGURATION commands.
- Load system services using SYS\_LOADABLE commands, which add and remove executive loaded images from the set of images loaded at boot time.
- Create and modify scheduling classes, which allow you to limit the amount of CPU time allotted to users on a system.
- Shut down systems using the SHUTDOWN NODE command.
- On Alpha and Integrity servers, detect all previously undiscovered tapes and media changers.
- On Alpha and Integrity servers, connect devices, load device drivers, and display configuration information using I/O commands.

## SYSMAN

### 9.1 SYSMAN Description

- On Alpha and Integrity servers, set the priority of processes so that they are dumped early during a selective dump.

#### 9.1.1 Defining Keys to Execute SYSMAN Commands

Instead of having to type lengthy command lines, SYSMAN enables you to define keys to execute SYSMAN commands. For example, you can define a key to execute a SET ENVIRONMENT command as follows:

```
SYSMAN> DEFINE/KEY/TERMINATE
  _Key name: KP0
  _Translation: "SET ENVIRONMENT/NODE=(NODE21,NODE22,NODE23) "
```

Once the key is defined, you can press keypad 0, and SYSMAN executes the SET ENVIRONMENT command. Note that key definitions are lost each time that you exit from SYSMAN, unless you define them in the SYSMAN initialization file. (See Section 9.1.2 for more information about executing commands from an initialization file.)

#### 9.1.2 Executing Commands from an Initialization File

You can create an initialization file that SYSMAN will use each time you invoke the utility. In the SYSMAN initialization file, you can perform tasks such as defining keys and setting the SYSMAN environment.

The default file specification for the SYSMAN initialization file is SYS\$LOGIN:SYSMANINI.INI. If you want your SYSMAN initialization file to have a different file specification, you must define the logical name SYSMANINI to point to the location of the file.

The following example is a sample initialization file in which several keys are defined:

```
$ TYPE SYSMANINI.INI
DEFINE/KEY/TERMINATE KP0 "SET ENVIRONMENT/CLUSTER/NODE=(NODE21,NODE22,NODE23,NODE24) "
DEFINE/KEY/TERMINATE KP1 "CONFIGURATION SHOW TIME"
DEFINE/KEY/TERMINATE KP2 "SHOW PROFILE"
.
.
.
```

## 9.2 SYSMAN Usage Summary

The System Management utility (SYSMAN) centralizes system management, enabling you to manage nodes or clusters from one location.

### Format

```
RUN SYS$SYSTEM:SYSMAN
```

#### Parameters

None.

## Description

To invoke SYSMAN, enter the following command at the DCL prompt:

```
$ RUN SYS$SYSTEM:SYSMAN
```

SYSMAN displays the following prompt at which you can enter SYSMAN commands using the standard rules of DCL syntax:

```
SYSMAN>
```

To exit from SYSMAN and return to the DCL command level, enter the EXIT command at the SYSMAN> prompt or press Ctrl/Z.

---

**Note**

---

SYSMAN has the following restrictions:

- You must have the OPER privilege on the local node and authorization for the OPER or SETPRV privilege on any remote nodes in the management environment.

You must also have the privileges required by individual commands, as each command in this chapter describes. To determine which privileges are required for DCL commands or for system management utilities, see the *HP OpenVMS DCL Dictionary* or the appropriate utility reference part of this manual.

- You cannot run SYSMAN from a batch job in any environment that requires a password.
- Some DCL commands, such as SHOW SYSTEM/CLUSTER, SET CLUSTER/QUORUM, MOUNT/CLUSTER, and some forms of the REPLY command, operate clusterwide by design. These commands should not be run using SYSMAN, unless the environment has been set to a single node. Similarly, operations on clusterwide logical names and tables operate clusterwide by design.
- If a SYSMAN user running with more than 125 total rights attempts to issue a SYSMAN command to a remote node within a cluster, the following error message is displayed:

```
SMI-E-RIGHTSLIM, Rights limit exceeded.
```

Note that this rights limitation includes a minimum of three identifiers that are granted during login when the process rights list is created:

- A UIC identifier
- A system identifier
- Depending upon the environment in which the process is operating, at least one environmental identifier

Users who want to run SYSMAN must have either one of the following items:

- A separate account with no more than 125 rights
  - Enough identifiers removed from their current account so that the total number of rights falls within the appropriate range
-

## **SYSMAN**

### **9.3 SYSMAN Commands**

### **9.3 SYSMAN Commands**

This section describes the SYSMAN commands and demonstrates their use. Table 9–1 summarizes each command.

**Table 9–1 SYSMAN Commands**

| <b>Command</b>                               | <b>Function</b>   |
|--|---|
| @ (Execute Procedure)                        | Requests that SYSMAN read subsequent command input from the specified file or device. |
| ALF ADD                                      | Adds a record to the automatic login facility (ALF) database.                         |
| ALF REMOVE                                   | Deletes one or more records from the automatic login facility (ALF) database.         |
| ALF SHOW                                     | Displays one or more records from the automatic login facility (ALF) database.        |
| ATTACH                                       | Transfers control from your current process to the specified process in your job.     |
| CLASS_SCHEDULE ADD                           | Creates a new scheduling class.   |
| CLASS_SCHEDULE DELETE                        | Deletes a scheduling class.   |
| CLASS_SCHEDULE MODIFY                        | Modifies the characteristics of a scheduling class.                                   |
| CLASS_SCHEDULE RESUME                        | Resumes a scheduling class that has been suspended.                                   |
| CLASS_SCHEDULE SHOW                          | Displays the characteristics of a scheduling class.                                   |
| CLASS_SCHEDULE SUSPEND                       | Temporarily suspends a scheduling class.  |
| CONFIGURATION SET<br>CLUSTER_AUTHORIZATION   | Updates security data in a local area cluster.  |
| CONFIGURATION SET TIME                       | Updates system time.  |
| CONFIGURATION SHOW CLUSTER_<br>AUTHORIZATION | Displays cluster security data.   |
| CONFIGURATION SHOW TIME                      | Displays current system time.   |
| DEFINE/KEY                                   | Defines a key to execute a SYSMAN command   |
| DISKQUOTA ADD                                | Adds an entry to a disk quota file.   |
| DISKQUOTA CREATE                             | Creates and enables a disk quota file for a volume that does not contain one.         |
| DISKQUOTA DELETE                             | Removes an entry from a quota file.   |
| DISKQUOTA DISABLE                            | Suspends disk quota operations on a volume.   |
| DISKQUOTA ENABLE                             | Resumes disk quota operations on a volume.  |
| DISKQUOTA MODIFY                             | Changes an entry in the quota file or adjusts the default quota and overdraft values. |
| DISKQUOTA REBUILD                            | Reconstructs the disk usage counts for all entries.                                   |
| DISKQUOTA REMOVE                             | Removes an entry from a disk quota file.  |
| DISKQUOTA SHOW                               | Displays disk quotas and usage counts.  |
| DO   | Executes a DCL command or DCL command procedure.                                      |
| ‡ DUMP_PRIORITY ADD                          | Adds an entry to the System Dump Priority registry file.                              |
| ‡ DUMP_PRIORITY LIST                         | Lists the contents of the System Dump Priority registry file.                         |

‡Alpha and Integrity servers specific

(continued on next page)

**Table 9–1 (Cont.) SYSMAN Commands**

| Command                | Function   |
|------------------------|--|
| ‡ DUMP_PRIORITY LOAD   | Loads the contents of the System Dump Priority registry file into memory for BUGCHECK to use.  |
| ‡ DUMP_PRIORITY MODIFY | Modifies an entry in the System Dump Priority registry file.   |
| ‡ DUMP_PRIORITY REMOVE | Removes a record from the System Dump Priority registry file.  |
| ‡ DUMP_PRIORITY SHOW   | Lists the contents of the in-memory copy of the System Dump Priority registry file.  |
| ‡ DUMP_PRIORITY UNLOAD | Clears the in-memory copy of the System Dump Priority registry file.   |
| EXIT                   | Terminates the SYSMAN session and returns control to the DCL command level.  |
| HELP                   | Provides information about SYSMAN commands.  |
| ‡ IO AUTOCONFIGURE     | Automatically identifies and configures all hardware devices attached to a system.   |
| ‡ IO CONNECT           | Connects devices and loads device drivers.   |
| ‡ IO CREATE_WWID       | Assigns a new device name to a new worldwide identifier (WWID).  |
| ‡ IO FIND_WWID         | Detects all previously undiscovered tapes and medium changers.   |
| ‡ IO LIST_WWID         | Lists all tape device worldwide identifiers (WWIDs) that are not yet configured on Fibre Channel.  |
| ‡ IO LOAD              | Loads an I/O driver.   |
| ‡ IO REBUILD           | Rebuilds all device configuration tables.  |
| ‡ IO REPLACE_WWID      | Replaces one worldwide identifier (WWID) with another.   |
| ‡ IO SCSI_PATH_VERIFY  | Checks each SCSI and FC path in the system to determine whether the attached device has been changed; if it has, the SCSI or FC path in the IO database is disconnected. |
| ‡ IO SET EXCLUDE       | Sets the permanent exclusion list to be used when configuring devices automatically.   |
| ‡ IO SET PREFIX        | Sets the prefix used to build the IOGEN Configuration Building Module (ICBM) names.  |
| ‡ IO SHOW BUS          | Lists the system's buses, node numbers, bus names, TR numbers, and base CSR addresses on the system.   |
| ‡ IO SHOW DEVICE       | Displays information about devices, their drivers, and their I/O databases.  |
| ‡ IO SHOW EXCLUDE      | Displays the permanent exclusion list used in the autoconfiguration of devices.  |
| ‡ IO SHOW PREFIX       | Displays the current prefix list used to produce the IOGEN Configuration Building Module (ICBM) names.   |
| LICENSE LOAD           | Activates a license that is registered in the LICENSE database.  |
| LICENSE UNLOAD         | Deactivates a license that is registered in the LICENSE database.  |

‡Alpha and Integrity servers specific

(continued on next page)

## SYSMAN

### 9.3 SYSMAN Commands

**Table 9–1 (Cont.) SYSMAN Commands**

| Command                   | Function   |
|---------------------------|--|
| PARAMETERS DISABLE CHECKS | Inhibits range checks on system parameter values specified in subsequent PARAMETERS SET commands.  |
| PARAMETERS ENABLE CHECKS  | Ensures that range checks are in effect. Enables range checks after a PARAMETERS DISABLE CHECKS command.   |
| PARAMETERS SET            | Modifies the value of a system parameter in the work area.   |
| PARAMETERS SHOW           | Displays the values of system parameters in the work area, plus the default, minimum, and maximum values of the parameters and their units of measure.   |
| PARAMETERS USE            | Initializes the current work area with system parameter values and the name of the site-independent command procedure.   |
| PARAMETERS WRITE          | Writes the system parameter values and the name of the site-independent command procedure from the work area to a parameter file, the current system parameter file, or the active system in memory. |
| RESERVED_MEMORY ADD       | On Alpha and Integrity servers, reserves an amount of physical memory, referred to as a memory reservation, in the Reserved Memory Registry data file.   |
| RESERVED_MEMORY EXTEND    | On Alpha and Integrity servers, adds memory sections if you want to accommodate more than one Resource Affinity Domain (RAD) for a single memory reservation.  |
| RESERVED_MEMORY FREE      | On running Alpha and Integrity servers, frees reserved memory.   |
| RESERVED_MEMORY LIST      | On Alpha and Integrity servers, provides a preview of this reservation as it is currently stored in the Reserved Memory Registry data file.  |
| RESERVED_MEMORY MODIFY    | On Alpha and Integrity servers, allows you to modify an existing entry in the Reserved Memory Registry data file.  |
| RESERVED_MEMORY REMOVE    | On Alpha and Integrity servers, removes a reserved memory entry from the Reserved Memory Registry data file.   |
| RESERVED_MEMORY SHOW      | On Alpha and Integrity servers, displays the memory reservations on the running system.  |
| SET ENVIRONMENT           | Establishes a management context for subsequent SYSMAN commands.   |
| SET PROFILE               | Modifies the default device and directory and the current privileges for the current management environment, and allows you to set DCL verification for future DO commands.                          |
| SET TIMEOUT               | Establishes the amount of time that SYSMAN waits for a node to respond.  |
| SHOW ENVIRONMENT          | Displays the current command context.  |
| SHOW KEY                  | Displays key definitions.  |
| SHOW PROFILE              | Displays the default device and directory and the current privileges.  |
| SHOW TIMEOUT              | Displays the current timeout period.   |
| SHUTDOWN NODE             | Shuts down one or more nodes simultaneously with a single command line.  |

(continued on next page)



**Table 9–1 (Cont.) SYSMAN Commands**

| <b>Command</b>       | <b>Function</b>  |
|----------------------|--|
| SPAWN                | Creates a subprocess of the current process, where the context of the subprocess is copied from the current process. |
| STARTUP ADD          | Adds an executable file or command procedure to the startup database.  |
| STARTUP DISABLE      | Prevents a component of the startup database from executing on one or more nodes in the environment.                 |
| STARTUP ENABLE       | Allows a component of the startup database to execute.   |
| STARTUP MODIFY       | Edits a record in the startup database describing how a startup component executes.                                  |
| STARTUP REMOVE       | Removes one or more components from the startup database.  |
| STARTUP SET DATABASE | Determines the default database.   |
| STARTUP SET OPTIONS  | Controls logging and display of information for one or more nodes in a cluster during startup.                       |
| STARTUP SHOW         | Displays the name of the current startup database or its contents.   |
| SYS_LOADABLE ADD     | Adds an executive loaded image to the set of images loaded at boot time.   |
| SYS_LOADABLE REMOVE  | Removes an executive loaded image from the set of images loaded at boot time.  |

## SYSMAN @ (Execute Procedure)

---

### @ (Execute Procedure)

Requests that SYSMAN read subsequent command input from the specific file or device.

### Format

@ filespec

### Parameter

#### filespec

Specifies either the input device or the command procedure you want to execute. The default file type is .COM. You cannot use wildcard characters in the file specification.

### Description

Use the execute procedure command to execute a command procedure containing SYSMAN commands. To execute the command procedure, invoke SYSMAN, place the at sign (@) command at the beginning of a command line, then specify the file name of the command procedure.

The command procedure can contain any valid SYSMAN command.

### Examples

```
1. $ CREATE ENV.COM
   SET ENVIRONMENT
   SHOW PROFILE Ctrl/Z
   $ RUN SYS$SYSTEM:SYSMAN
   SYSMAN> @ENV.COM

%SYSMAN-I-DEFDIR, default directory on node --
                SYS$SYSROOT:[SYSMGR]
%SYSMAN-I-DEFPRIV, default process privileges on node --
   CMKRNL
   CMEXEC
   SYSNAM
   .
   .
   .
   GRPPRV
   READALL
   SECURITY
SYSMAN>
```

This example shows how to create a command procedure that sets the SYSMAN environment to the local node, and displays the current profile. These commands execute when you enter the @ENV.COM command.

## **SYSMAN @ (Execute Procedure)**

```
2. $ CREATE TIME.COM
   SET ENVIRONMENT/CLUSTER
   CONFIGURATION SHOW TIME 
   $ RUN SYSSYSTEM:SYSMAN
   SYSMAN> @TIME
```

```
System time on node NODE23: 19-JUN-2002 13:32:19.45
System time on node NODE24: 19-JUN-2002 13:32:27.79
System time on node NODE25: 19-JUN-2002 13:32:58.66
```

This example shows how to create and execute a command procedure that shows the current date and time for all the nodes in the cluster.

## **SYSMAN ALF ADD**

---

### **ALF ADD**

Adds a new record to the automatic login facility (ALF) database. You can also create records for proxy accounts.

Requires read (R) and write (W) access to the SYSALF database (SYS\$SYSTEM:SYSALF.DAT by default).

### **Format**

ALF ADD device user

### **Parameters**

#### **device**

Specifies the terminal name or port name that you want to assign to a user name. The parameter device must be a terminal name if you do not specify qualifiers on the command line, and can be either a logical name or an abbreviated device name. This parameter accepts a maximum of 63 characters, including devices for proxy accounts.

#### **user**

Specifies the user name of the account that you want to assign to a particular terminal or port.

### **Qualifiers**

#### **/TERMINAL (default)**

Checks whether the device name you specified is a terminal on the target system. The parameter device can be a logical name or an abbreviated device name, which SYSMAN translates to a full device name.

#### **/PORT**

Checks whether the device name you specified is a valid port. If the port name contains special characters, such as a slash (/), or if it contains lowercase letters that you want to preserve, you must enclose the port name within quotation marks (" ").

Be aware that anything within quotation marks is written literally to the ALF database file. For example, if the actual port name contains uppercase letters as well as special characters, be sure to specify uppercase letters within the quotation marks. Otherwise, a mismatch will occur between the actual port name and what is specified in the SYSALF.DAT file.

#### **/PROXY**

Checks that the device name is in the NODE::USERNAME format.

#### **/LOG**

Displays the device names and user names as they are added to the ALF database.

## **Description**

You can use the ALF ADD command to associate a terminal or port with a particular user name. This will enable certain users to log in to certain terminals or ports without specifying a user name.

The ALF ADD command adds a new record to the ALF database.

## **Examples**

1. SYSMAN> ALF ADD TTA3 JBERGERON  
SYSMAN> ALF ADD "MN34C3/LC-1-2" FMARTIN /PORT

In this example, the first command assigns terminal TTA3 to user JBERGERON. The second command assigns port MN34C3/LC-1-2 to user FMARTIN.

2. SYSMAN> ALF ADD VMS:.ZKO.VMSORG.SYSMAN.CLIENT1::SYSTEM FOOBAR

In this example, VMS:.ZKO.VMSORG.SYSMAN.CLIENT1::SYSTEM is the value for the device parameter, which is assigned to FOOBAR.

# SYSMAN ALF REMOVE

---

## ALF REMOVE

Removes one or more records from the ALF database.

Requires read (R) and write (W) access to the SYSALF database (SYS\$SYSTEM:SYSALF.DAT).

### Format

ALF REMOVE device

### Parameter

#### **device**

Specifies the terminal name or port name whose record you want to remove from ALF. The device name is required, even if you use qualifiers with the ALF REMOVE command.

You can use wildcard characters in the terminal name or port name. For example, if you specify the device TTA\*, the system removes all records that start with the string TTA. The system does not, however, remove any records that start with the string <nodename>\$TTA (where <nodename> is the system's SCSNODE name). To remove records starting with \$, you would have to specify \$TTA\* or use two wildcards: \*TTA\*.

If you omit wildcard characters and enter a REMOVE command, SYSMAN attempts to match the device name exactly. If more than one record matches the criteria, SYSMAN displays an error message.

### Qualifiers

#### **/USERNAME=user**

Enables you to remove a record in ALF for a specific user associated with a device. You must also enter the device when you use the /USERNAME qualifier. You can use wildcard characters with the /USERNAME qualifier.

#### **/CONFIRM**

Displays a message asking you to verify that you want to remove the record.

#### **/LOG**

Displays each device name and user name after it has been removed from the ALF database.

### Description

The ALF REMOVE command removes one or more records from the ALF database.

### Examples

1. SYSMAN> ALF REMOVE WORK1/USERNAME=\*

The command in this example removes the records of the WORK1 device from the ALF database for all users. The asterisk (\*) replaces user names.

2. SYSMAN> ALF REMOVE \*/USERNAME=\*

The command in this example removes all records from the ALF database. The first asterisk (\*) replaces device names; the second asterisk replaces user names.

3. SYSMAN> ALF REMOVE TTA3:  
SYSMAN> ALF REMOVE \*/USERNAME=SMITHSON

In this example, the first command removes the record for terminal TTA3. The second command removes all records (for all devices) assigned to user name SMITHSON.

4. SYSMAN> ALF REMOVE \*TTA\*

The command in this example removes all records for devices containing the string TTA.

5. SYSMAN> REMOVE TTA

This command produces the following error message:

```
%SYSMAN-E-ALFWILCRDREQ, more than one record might match - Wildcard or  
unit number of device required.
```

---

### Note

---

HP recommends that you use caution when issuing REMOVE commands from Version 6.1 or lower SYSMAN clients to Version 6.2 or higher systems.

---

For example, the following command issued from a system running OpenVMS Version 6.1 or lower to a system running OpenVMS Version 6.2 produces no error messages and deletes all records that match FOOBAR\$TTA:

```
SYSMAN> SET ENVIRONMENT/NODE=FOOBAR      ! FOOBAR runs OpenVMS Version 6.2  
%SYSMAN-I-ENV, current command environment:  
      Individual nodes: FOOBAR  
      Username SYSTEM will be used on nonlocal nodes  
SYSMAN> ALF REMOVE TTA                  ! Does not produce an error message  
  
SYSMAN>
```

If you issue the same command from a system running OpenVMS Version 6.1 or lower to another system running OpenVMS Version 6.1 or lower, it produces the following error message:

```
%SYSMAN-I-NODERR, error returned from node FOO  
-SMI-E-ALFNOMATCH, no records matched search criteria
```

This is due to incorrect processing of wildcards prior to OpenVMS Version 6.2.

## **ALF SHOW**

Displays one or more records from the ALF database.

Requires read (R) and write (W) access to the SYSALF database (SYS\$SYSTEM:SYSALF.DAT).

### **Format**

ALF SHOW [device]

### **Parameter**

#### **[device]**

Specifies the terminal name or port name whose record you want to display. You can use wildcard characters in the terminal name or port name. Certain restrictions in wildcard matching of ALF records exist, as shown in the examples section.

### **Qualifiers**

#### **/USERNAME=user**

Displays the records held by the specified user. You can use wildcard characters with this qualifier.

#### **/OUTPUT[=filespec]**

Directs the output of the command to a file. If you do not include a file specification with this qualifier, SYSMAN writes the output to the file SYSMAN.LIS in your default directory.

### **Description**

The ALF SHOW command displays one or more records in the ALF database.

### **Examples**

1. SYSMAN> ALF SHOW TTA\* /USERNAME=MANESS /OUTPUT=ALF.TXT

In this example, the records for all terminals named TTAx that are assigned to user MANESS are selected and directed to the file ALF.TXT.

2. SYSMAN> ALF SHOW TTA\*

This command displays only those records that start with the string TTA.

3. SYSMAN> ALF SHOW TTA

This command displays only those records that start with the string <nodename>\$TTA.

4. SYSMAN> ALF SHOW \*TTA

This command displays records that have device names ending with TTA.

5. SYSMAN> ALF SHOW \*TTA\*

This command displays all records that contain the string TTA.



---

## ATTACH

Transfers control from your current process (which then hibernates) to the specified process in your job.

The ATTACH and SPAWN commands cannot be used if your terminal has an associated mailbox.

### Format

ATTACH [process-name]

### Parameter

#### **process-name**

Specifies the name of a parent process or a spawned subprocess to which control passes. The process must already exist, be part of your current job tree, and share the same input stream as your current process. However, the process cannot be your current process or a subprocess created with the /NOWAIT qualifier.

Process names can contain from 1 to 15 alphanumeric characters. If a connection to the specified process cannot be made, an error message is displayed.

### Qualifier

#### **/PARENT**

Enables you to attach to the parent process. If no parent process exists, you receive an error message.

### Description

The ATTACH command connects your input stream to another process. You can use the ATTACH command to change control from one subprocess to another subprocess or to the parent process.

When you enter the ATTACH command, the parent process goes into hibernation and your input stream connects to the specified destination process. You can use the ATTACH command to connect to a subprocess that is part of a current job (left hibernating as a result of the SPAWN/WAIT command or another ATTACH command) as long as the connection is valid. No connection can be made to the current process, to a process that is not part of the current job, or to a process that does not exist. If you attempt any of these connections, you receive an error message.

You can also use the ATTACH command in conjunction with the SPAWN/WAIT command to return to a parent process without terminating the created subprocess. See the description of the SPAWN command for more details.

## **SYSMAN ATTACH**

### **Example**

```
$ SPAWN
%DCL-S-SPAWNED, process SYSTEM_1 spawned
%DCL-S-ATTACHED, terminal now attached to process SYSTEM_1
$ RUN SYS$SYSTEM:SYSMAN
SYSMAN> ATTACH SYSTEM
%DCL-S-RETURNED, control returned to process SYSTEM
$
```

In this example, the SPAWN command creates a subprocess (SYSTEM\_1). After you invoke SYSMAN and enter the ATTACH command, you transfer the terminal's control back to the parent process (SYSTEM).

## **CLASS\_SCHEDULE ADD**

The ADD command creates a new scheduling class.

The class scheduler provides the ability to limit the amount of CPU time that a system's users receive by placing users in scheduling classes. Each class is assigned a percentage of the overall system CPU time. As the system runs, the combined set of users in a class is limited to the percentage of CPU execution time allocated to their class.

Users might get some additional CPU time if the qualifier `/WINDFALL` is enabled for their scheduling class. Enabling the qualifier `/WINDFALL` allows the system to give a small amount of CPU time to a scheduling class when the scheduling class's allotted time has been depleted, but a free CPU is available.

### **Format**

```
CLASS_SCHEDULE ADD class_name
```

### **Parameter**

#### **class\_name**

Specifies the name of the scheduling class. You must specify a class name with the ADD command. The maximum length for this name is 16 characters.

### **Qualifiers**

#### **/ACCOUNT**

Specifies which user is part of this scheduling class. This is part of a user's SYSUAF record.

The syntax for this qualifier is as follows:

```
[/ACCOUNT = (name1, name2,...name"n")]
```

#### **/CPULIMIT**

Defines the maximum amount of CPU time that this scheduling class can receive for the specified days and hours. You must specify this qualifier when adding a class.

The syntax for this qualifier is as follows:

```
/CPULIMIT = ([primary], [h1-h2=time%],[h1=time%],  
[,...],[secondary],[h1-h2=time%],[h1=time%],[,...])
```

The `h1-h2=time%` syntax allows you to specify a range of hours followed by the maximum amount of CPU time (expressed as a percentage) to be associated with this set of hours. The first set of hours after the keyword `PRIMARY` specifies hours on primary days; the set of hours after the keyword `SECONDARY` specifies hours on secondary days. The hours are inclusive; if you class schedule a given hour, access extends to the end of that hour.

#### **/PRIMEDAYS**

Allows you to define which days are primary days and which days are secondary days.

The syntax for this qualifier is as follows:

```
[/PRIMEDAYS = ([no]day[,...])]
```

## **SYSMAN CLASS\_SCHEDULE ADD**

You specify primary days as MON, TUE, WED, THU, FRI, SAT, and SUN. You specify secondary days as NOMON, NOTUE, NOWED, NOTHU, NOFRI, NOSAT, and NOSUN.

The default is MON through FRI and NOSAT and NOSUN. Any days omitted from the list take their default value. You can use the DCL command, SET DAY, to override the class definition of primary and secondary days.

### **/UIC**

Specifies which users are part of this scheduling class. This is part of a user's SYSUAF record.

The syntax for this qualifier is as follows:

```
[/UIC = (uic1,uic2,...uic"n")]
```

### **/USERNAME**

Specifies which user is part of this scheduling class. This is part of a user's SYSUAF record.

The syntax for this qualifier is as follows:

```
[/USERNAME = (name1, name2,...name"n")]
```

### **/WINDFALL**

Specifies that all processes in the scheduling class are eligible for windfall.

The syntax for this qualifier is as follows:

```
[/WINDFALL])
```

By enabling windfall, you allow processes in the scheduling class to receive a "windfall", that is, a small percentage of CPU time, when the class's allotted CPU time has been depleted, and a CPU is idle. Rather than let the CPU remain idle, you might decide that it is better to let these processes execute, even if it means giving them more than their allotted time.

The default value is for windfall to be disabled.

## **Description**

The format for the CLASS\_SCHEDULE ADD command is as follows:

```
SYSMAN> CLASS_SCHEDULE ADD class_name
```

You can use the /ACCOUNT, /UIC, or /USERNAME qualifier to specify which users are to be part of a scheduling class.

### **The Class Scheduler Database**

The class scheduler database is a permanent database that allows OpenVMS to class schedule processes automatically after a system has been booted and rebooted. This database resides on the system disk in SYS\$SYSTEM:VMS\$CLASS\_SCHEDULE.DATA. SYSMAN creates this file as an RMS indexed file when the first scheduling class is created with the SYSMAN command CLASS\_SCHEDULE ADD.

You can have a common class scheduler database for all cluster nodes, or you can have a separate database for one node or for a small group of nodes. Using a common database can be helpful in simplifying system management. However, you must be aware of the issues raised in the following examples:

- Example 1

## SYSMAN CLASS\_SCHEDULE ADD

Within a single database—common or separate—you can have only one set of parameters for each class. For example,

```
SYSMAN> SET ENV/NODE=X
SYSMAN> CLASS ADD class1 /USERNAME=(user1) /CPULIMIT=(0-2=100%,3-23=30%)
SYSMAN> SET ENV/NODE=Y
SYSMAN> CLASS ADD class1 /USERNAME=(user1) /CPULIMIT=(0-2=40%,3-23=20%)
```

With a database that is common to both nodes X and Y, the second command produces an error because you have given the same class different parameters. With separate databases for nodes X and Y, the second command works.

- **Example 2**

The system must also be able to assign a process to a unique class. You can specify the same user—or other identifying information—in several classes as long as you define these classes on separate nodes. For example:

```
SYSMAN> SET ENV/NODE=X
SYSMAN> CLASS ADD class1 /USERNAME=(user1) /CPULIMIT=(0-2=100%,3-23=30%)
SYSMAN> SET ENV/NODE=Y
SYSMAN> CLASS ADD class2 /USERNAME=(user1) /CPULIMIT=(0-2=40%,3-23=20%)
```

This example works on a database that is common to both nodes X and Y because the two sets of parameters also have different class names. The system can determine the class for user1 by checking the node on which user1 is running.

- **Example 3**

The following example is incorrect on both common and separate databases because the system cannot determine whether user1 is a member of class1 or class2, since they are both defined for NODE X.

```
SYSMAN> SET ENV/NODE=X
SYSMAN> CLASS ADD class1 /USERNAME=(user1) /CPULIMIT=(0-2=100%,3-23=30%)
SYSMAN> CLASS ADD class2 /USERNAME=(user1) /CPULIMIT=(0-2=40%,3-23=20%)
```

- **Example 4**

In addition to specifying nodes explicitly, as shown in the preceding examples, you can also specify that a class applies to the entire cluster. For example:

```
SYSMAN> SET ENV /CLUSTER
SYSMAN> CLASS ADD class1 /USERNAME=(user1) /CPULIMIT=(0-2=100%,3-23=30%)
```

In this example, not only is class1 defined for all nodes in the cluster, but class1 will also be defined for any node that you might add to the cluster later—as long as the new node uses the same database.

Note that if you define a class with the environment set to CLUSTER, the command SYSMAN> CLASS SHOW/FULL lists that class with the notation "Nodes: All Cluster Members," even if the database is not common to all cluster nodes. To prevent confusion, HP recommends using a common database.

## SYSMAN CLASS\_SCHEDULE ADD

### Defining the Logical Name VMS\$CLASS\_SCHEDULE

If you wish to have a common class scheduler database on a cluster with different system disks, or if you want to have a separate database for each node on a cluster with a common system disk, on each node define the system logical name VMS\$CLASS\_SCHEDULE to point to the location of the database that you want that node to use. For example, in SYSTARTUP\_VMS.COM, include the following command:

```
$ DEFINE/SYSTEM VMS$CLASS_SCHEDULE disk:[directory]VMS$CLASS_SCHEDULE.DATA
```

where:

*disk:[directory]* represents the disk and directory where you want the database file to reside.

### The Class Scheduler Database and Process Creation

By using a permanent class scheduler, a process is placed in a scheduling class, if appropriate, at process creation time. When a new process is created, the system determines whether this process belongs to a scheduling class. To determine this, the system relies on data in the SYSUAF file. Because the Loginout image already has information about the process from this file, Loginout class-schedules the process if it determines that the process belongs to a scheduling class.

Two other types of processes to consider during process creation are subprocess and detached process:

- A subprocess becomes part of the same scheduling class as the parent process, even though the subprocess might not match the criteria of the class. That is, the subprocess's user and account name and/or UIC might not be part of the class's record.
- A detached process joins the same scheduling class as the process that creates it unless the detached process executes the LOGINOUT image (LOGINOUT.EXE) during process creation. If a detached process executes LOGINOUT, it joins a class if it matches the class criteria in the class scheduler database.

Although a process can join a scheduling class at process creation time, you can change or modify its scheduling class during runtime with the SET PROCESS/SCHEDULING\_CLASS command.

### Determining If a Process is Class-Scheduled

You can determine whether a process is class-scheduled by any of the following methods:

- Either of the following DCL commands:

```
$ SHOW SYSTEM/SCHEDULING_CLASS  
$ SHOW SYSTEM/FULL
```

For more information about the DCL command SHOW SYSTEM, see *OpenVMS DCL Dictionary: N-Z*.

- The SYS\$GETJPI system service, using the JPI\$\_SCHED\_CLASS\_NAME item  
For more information about the SYS\$GETJPI system service, see *OpenVMS System Services Reference Manual: A-GETUAI*.
- The AUTHORIZE utility

## **SYSMAN CLASS\_SCHEDULE ADD**

When a new user is added to the SYSUAF file, or when a user's record is modified, AUTHORIZE searches the class scheduler database file to determine if this user is a member of a scheduling class. If it is, then AUTHORIZE displays the following message:

```
UAF-I-INCLASS, user belongs to at least 1 selecting class
```

For more information about the AUTHORIZE utility, see that chapter in this manual.

## **SYSMAN CLASS\_SCHEDULE DELETE**

---

### **CLASS\_SCHEDULE DELETE**

The DELETE subcommand deletes a scheduling class from the class scheduler database file.

#### **Format**

```
CLASS_SCHEDULE DELETE class_name
```

#### **Parameter**

**class\_name**

Specifies the name of the scheduling class. You must specify a class name with the DELETE command. The maximum length for this name is 16 characters.

#### **Qualifiers**

None.



## **CLASS\_SCHEDULE MODIFY**

The MODIFY subcommand changes the characteristics of a scheduling class.

### **Format**

```
CLASS_SCHEDULE MODIFY class_name
```

### **Parameter**

#### **class\_name**

Specifies the name of the scheduling class. You must specify a class name with the MODIFY command. The maximum length for this name is 16 characters.

### **Qualifiers**

#### **/ACCOUNT**

Specifies which user is part of this scheduling class. This is part of a user's SYSUAF record.

The syntax for this qualifier is as follows:

```
[/ACCOUNT = (name1, name2, ...name"n")]
```

#### **/CPULIMIT**

Defines the maximum amount of CPU time that this scheduling class can receive for the specified days and hours.

The syntax for this qualifier is as follows:

```
/CPULIMIT = ([primary], [h1-h2=time%],[h1=time%],  
[,...],[secondary],[h1-h2=time%],[h1=time%],[,...])
```

The `h1-h2=time%` syntax allows you to specify a range of hours followed by the maximum amount of CPU time (expressed as a percentage) to be associated with this set of hours. The first set of hours after the keyword PRIMARY specifies hours on primary days; the set of hours after the keyword SECONDARY specifies hours on secondary days. The hours are inclusive; if you class schedule a given hour, access extends to the end of that hour.

#### **/PRIMEDAYS**

Allows you to define which days are primary days and which days are secondary days.

The syntax for this qualifier is as follows:

```
[/PRIMEDAYS = ([no]day[,...])]
```

You specify primary days as MON, TUE, WED, THU, FRI, SAT, and SUN. You specify secondary days as NOMON, NOTUE, NOWED, NOTHU, NOFRI, NOSAT, and NOSUN.

The default is MON through FRI and NOSAT and NOSUN. Any days omitted from the list take their default value. You can use the DCL command, SET DAY, to override the class definition of primary and secondary days.

#### **/UIC**

Specifies which users are part of this scheduling class. This is part of a user's SYSUAF record.

## **SYSMAN CLASS\_SCHEDULE MODIFY**

The syntax for this qualifier is as follows:

```
[/UIC = (uic1,uic2,...uic"n")]
```

### **/USERNAME**

Specifies which user is part of this scheduling class. This is part of a user's SYSUAF record.

The syntax for this qualifier is as follows:

```
[/USERNAME = (name1, name2,...name"n")]
```

### **/WINDFALL**

Specifies that all processes in the scheduling class are eligible for windfall.

The syntax for this qualifier is as follows:

```
[/WINDFALL])
```

By enabling windfall, you allow processes in the scheduling class to receive a "windfall," that is, a small percentage of CPU time, when the class's allotted CPU time has been depleted and a CPU is idle. Rather than let the CPU remain idle, you might decide that it is better to let these processes execute, even if it means giving them more than their allotted time.

The default value is for windfall to be disabled.

## **Description**

To remove a time restriction, specify the time percentage as "none" for the particular range of hours.

To remove a name or uic value, you must specify a minus sign in front of each name or value.

## **CLASS\_SCHEDULE RESUME**

The RESUME subcommand complements the suspend command. You use this command to resume a scheduling class that is currently suspended.

### **Format**

```
CLASS_SCHEDULE RESUME class_name
```

### **Parameter**

**class\_name**

Specifies the name of the scheduling class. You must specify a class name with the RESUME command. The maximum length for this name is 16 characters.

### **Qualifiers**

None.

## **SYSMAN CLASS\_SCHEDULE SHOW**

---

### **CLASS\_SCHEDULE SHOW**

The SHOW subcommand displays the characteristics of a scheduling class.

#### **Format**

```
CLASS_SCHEDULE SHOW [class_name] [/qualifier]
```

#### **Parameter**

##### **class\_name**

Specifies the name of the scheduling class. You must specify a class name or the /ALL qualifier with the SHOW command. The maximum length for the class name is 16 characters.

#### **Qualifiers**

##### **/ALL**

Displays all scheduling classes. The qualifier must be specified if no class name is given.

##### **/FULL**

Displays all information about this scheduling class.

#### **Description**

By default, a limited display of data is shown by the SHOW subcommand. The default displays the following:

- Name
- Maximum CPU time or times for each range of hours
- Primary days and secondary days
- Windfall settings

## **CLASS\_SCHEDULE SUSPEND**

The SUSPEND subcommand suspends the specified scheduling class.

### **Format**

```
CLASS_SCHEDULE SUSPEND class_name
```

### **Parameter**

**class\_name**

Specifies the name of the scheduling class. You must specify a class name with the SUSPEND command. The maximum length for this name is 16 characters.

### **Qualifiers**

None.

### **Description**

When you suspend a scheduling class, all processes that are part of the scheduling class remain as part of the class but are granted unlimited CPU time.

# SYSMAN CONFIGURATION SET CLUSTER\_AUTHORIZATION

---

## CONFIGURATION SET CLUSTER\_AUTHORIZATION

Modifies security data in a local area cluster.

Requires SYSPRV privilege.

### Format

CONFIGURATION SET CLUSTER\_AUTHORIZATION

### Parameters

None.

### Qualifiers

#### **/GROUP\_NUMBER=[n]**

Specifies the cluster group number that is recorded in SYS\$SYSTEM:CLUSTER\_AUTHORIZE.DAT. A group number uniquely identifies each local area cluster on a single Ethernet. This number must be in the range from 1 to 4095 or 61440 to 65535.

#### **/PASSWORD=password**

Specifies a password for cluster access. A password consists of 1 to 31 characters, including alphanumeric characters, dollar signs, and underscores. A password provides a second level of validation to ensure the integrity of individual clusters on the same Ethernet that accidentally use identical group numbers. A password also prevents an intruder who discovers the group number from joining the cluster.

### Description

The CONFIGURATION SET CLUSTER\_AUTHORIZATION command modifies the group number and password of a local area cluster, as recorded in SYS\$SYSTEM:CLUSTER\_AUTHORIZE.DAT. If your configuration has multiple system disks, SYSMAN automatically updates each copy of CLUSTER\_AUTHORIZE.DAT, provided the environment is defined as a cluster (SET ENVIRONMENT/CLUSTER). For more information about CLUSTER\_AUTHORIZE.DAT, see *HP OpenVMS Cluster Systems*.

---

#### **Caution**

---

If you change either the group number or the password, you must reboot the entire cluster.

---

The file CLUSTER\_AUTHORIZE.DAT is initialized during execution of CLUSTER\_CONFIG.COM and maintained through SYSMAN. Under normal conditions, altering records in the CLUSTER\_AUTHORIZE.DAT file interactively is not necessary. To protect the integrity of the cluster membership use the CONFIGURATION SET CLUSTER\_AUTHORIZATION command.

## SYSMAN CONFIGURATION SET CLUSTER\_AUTHORIZATION

### Example

```
SYSMAN> SET ENVIRONMENT/CLUSTER/NODE=NODE21
SYSMAN> SET PROFILE /PRIVILEGES=SYSPRV
SYSMAN> CONFIGURATION SET CLUSTER_AUTHORIZATION/PASSWORD=GILLIAN
%SYSMAN-I-CAFOLDGROUP, existing group will not be changed
%SYSMAN-I-GRPNOCHG, Group number not changed
SYSMAN-I-CAFREBOOT, cluster authorization file updated.
The entire cluster should be rebooted.
```

The CONFIGURATION SET CLUSTER\_AUTHORIZATION command in this example sequence modifies the cluster password. Note that the environment is defined to be a cluster, and the SYSPRV privilege is established before entering the CONFIGURATION SET CLUSTER\_AUTHORIZATION command.

# SYSMAN CONFIGURATION SET TIME

---

## CONFIGURATION SET TIME

Modifies the current system time.

Requires OPER, LOG\_IO, and SYSPRV privileges, and, in a cluster environment, SYSLCK privilege.

### Format

CONFIGURATION SET TIME [time]

### Parameters

None.

### Qualifiers

None.

### Description

The CONFIGURATION SET TIME command enables you to reset the system time. Specify a time value using the following format:

[dd-mmm-yyyy[:]] [hh:mm:ss.cc]

You can also enter a delta time value. For more information about time formats, see the *OpenVMS User's Manual*.

In an environment of individual nodes, SYSMAN sets the time to the specified value on each node. Without a time specification, SYSMAN sets the time according to the time-of-year clock on each node.

In an OpenVMS Cluster environment, SYSMAN sets the time to the specified value on each node. If you do not specify a value, SYSMAN uses the time-of-year clock. In a local cluster, SYSMAN reads the clock on the node from which you are executing SYSMAN and assigns this value to all nodes in the cluster. In a remote OpenVMS Cluster, SYSMAN reads the clock on the target node in the cluster and assigns that value to all nodes. Note that the time-of-year clock is optional for some processors; for more information, see your processor handbook.

SYSMAN uses special processing in an OpenVMS Cluster environment to ensure that all processors in the cluster are set to the same time. Because of communication and processing delays, it is not possible to synchronize clocks exactly. However, the variation is typically less than a few hundredths of a second. If SYSMAN cannot set the time to within one half second of the specified time, you receive a warning message that names the node that failed to respond quickly enough.

As a result of slight inaccuracies in each processor clock, times on various members of a cluster tend to drift apart. The following procedure synchronizes system times in a cluster environment:



## SYSMAN CONFIGURATION SET TIME

```
$ SYNCH CLOCKS:  
$ RUN SYSS$SYSTEM:SYSMAN  
    SET ENVIRONMENT/CLUSTER  
    CONFIGURATION SET TIME  
    EXIT  
$ WAIT 6:00:00  
$ GOTO SYNCH_CLOCKS
```

The procedure sets the time on all cluster nodes to the value obtained from the local time-of-year clock, waits 6 hours, then resets the time for the cluster.

### Example

```
SYSMAN> SET ENVIRONMENT/NODE=(NODE21,NODE22,NODE23)  
SYSMAN> SET PROFILE /PRIVILEGE=LOG IO  
SYSMAN> CONFIGURATION SET TIME 12:38:00
```

The CONFIGURATION SET TIME command in this example sequence modifies the system time on NODE21, NODE22, and NODE23.

# SYSMAN CONFIGURATION SHOW CLUSTER\_AUTHORIZATION

---

## CONFIGURATION SHOW CLUSTER\_AUTHORIZATION

Displays the group number and multicast address of a local area cluster.  
Requires SYSPRV privilege.

### Format

CONFIGURATION SHOW CLUSTER\_AUTHORIZATION

### Parameters

None.

### Qualifier

**/OUTPUT[=filespec]**

Redirects output from SYS\$OUTPUT to the specified file. If no file specification is provided, SYSMAN writes the output to SYSMAN.LIS in the current directory.

### Description

The CONFIGURATION SHOW CLUSTER\_AUTHORIZATION command displays the group number and multicast address, and Ethernet address used to send a message to all nodes in the cluster. The group number and multicast address are recorded in SYS\$SYSTEM:CLUSTER\_AUTHORIZE.DAT during the CLUSTER\_CONFIG dialog.

In a cluster or multinode environment, SYSMAN displays the group number of the first node and then displays the names of any nodes in the cluster whose group numbers, passwords, or both, are different.

### Example

```
SYSMAN> SET ENVIRONMENT/CLUSTER/NODE=NODE21
.
.
.
SYSMAN> SET PROFILE /PRIVILEGE=SYSPRV
SYSMAN> CONFIGURATION SHOW CLUSTER AUTHORIZATION
Node NODE23: Cluster group number 65240
Multicast address: AB-00-04-01-F2-FF
```

The CONFIGURATION SHOW CLUSTER\_AUTHORIZATION command in this example displays the group number and multicast address of NODE21. Because the group number and password on other nodes in the cluster are identical, no further information is displayed.

## **CONFIGURATION SHOW TIME**

Displays the current date and system time to the nearest hundredth of a second.

### **Format**

CONFIGURATION SHOW TIME

### **Parameters**

None.

### **Qualifier**

**/OUTPUT[=filespec]**

Redirects output from SYS\$OUTPUT to the specified file. If no file specification is provided, SYSMAN writes the output to SYSMAN.LIS in the current directory.

### **Example**

```
SYSMAN> SET ENVIRONMENT/CLUSTER/NODE=NODE21
.
.
.
SYSMAN> CONFIGURATION SHOW TIME
System time on node NODE21: 19-JUN-2002 13:32:19.45
System time on node NODE22: 19-JUN-2002 13:32:27.79
System time on node NODE23: 19-JUN-2002 13:32:58.66
```

The CONFIGURATION SHOW TIME command in this example displays the system times for all nodes in the cluster.

# SYSMAN DEFINE/KEY

---

## DEFINE/KEY

Defines a key to execute a SYSMAN command. This enables you to press the key to enter a command, instead of typing the command name.

### Format

DEFINE/KEY key-name string

### Parameters

#### key-name

Specifies the name of the key you are defining. Use the key names in the following table when defining keys:

| Key Name              | VT100      | LK201/LK401            |
|-----------------------|------------|------------------------|
| PF1                   | PF1        | PF1                    |
| PF2                   | PF2        | PF2                    |
| PF3                   | PF3        | PF3                    |
| PF4                   | PF4        | PF4                    |
| KP0, KP1–KP9          | keypad 0–9 | keypad 0–9             |
| PERIOD                | period key | period key             |
| COMMA                 | comma key  | comma key              |
| MINUS                 | minus key  | minus key              |
| ENTER                 | ENTER key  | ENTER key              |
| UP, DOWN, LEFT, RIGHT | arrow keys | arrow keys             |
| FIND, INSERT_HERE     | –          | Find, Insert Here keys |
| REMOVE, SELECT        | –          | Remove, Select keys    |
| PREV_SCREEN           | –          | Previous Screen key    |
| NEXT_SCREEN           | –          | Next Screen key        |
| HELP, DO              | –          | Help, Do keys          |
| F6–F10, F11–F14       | –          | function keys          |
| F17–F20               | –          | function keys          |

#### string

Specifies the string you want entered when you press the defined key. For example, you can define string as the SYSMAN command SHOW ENVIRONMENT or SHOW PROFILE.

### Qualifiers

#### /ECHO (default)

#### /NOECHO

Specifies whether the command line echoes after you press the defined key. Note that you cannot define a key using both the /NOECHO and /NOTERMINATE qualifiers.

**/IF\_STATE=state\_list****/NOIF\_STATE**

Specifies a list of states, any one of which must be set in order to enable the specified key definition. If you omit or negate this qualifier, the current state prevails.

**/LOCK\_STATE****/NOLOCK\_STATE (default)**

Retains the state specified by the /SET\_STATE qualifier until you use the /SET\_STATE qualifier again to change it.

**/SET\_STATE****/NOSET\_STATE**

Associates a state with the key you are defining. A state name can be any alphanumeric string. If you omit or negate this qualifier, the current state remains unchanged. You cannot define a key using both the /SET\_STATE and /TERMINATE qualifiers.

**/TERMINATE****/NOTERMINATE**

Determines whether the specified command string executes when you press the key. When you use /NOTERMINATE, you must press the Return key to execute the command string. You cannot define a key using both the /SET\_STATE and /TERMINATE qualifiers.

## Description

The DEFINE/KEY command assigns a key to a SYSMAN command. This enables you to execute the command by pressing the key. You can confirm which keys you have defined by using the SHOW KEY command.

When you exit from SYSMAN, any SYSMAN key definitions you established will be lost unless you define them in a SYSMAN initialization file. (See Section 9.1.2.)

## Examples

1. SYSMAN> DEFINE /KEY PF1 "SHOW PROFILE"

This example shows how to define the keypad key PF1 as the SYSMAN command SHOW PROFILE. To execute the SHOW PROFILE command, press PF1 and then the Return key.

2. SYSMAN> DEFINE /KEY KP0 /TERMINATE "CONFIGURATION SHOW TIME"

This example shows how to define the keypad key 0 as the CONFIGURATION SHOW TIME command. The /TERMINATE qualifier causes the SYSMAN command to execute when you press keypad key 0 without having to press Return.

# SYSMAN DISKQUOTA ADD

---

## DISKQUOTA ADD

Adds an entry to a disk quota file and initializes the usage count to zero.

Requires write (W) access to the quota file.

### Format

```
DISKQUOTA ADD owner
```

### Parameter

#### **owner**

Specifies the user identification code (UIC) or rights identifier for which the quota entry is added. You can specify the UIC in numeric or alphanumeric format. For complete information about UIC specification, see the *HP OpenVMS Guide to System Security*.

Rights identifiers are granted with the Authorize utility and use an ID format rather than a UIC format. For a complete description of rights identifiers, see the *HP OpenVMS Programming Concepts Manual*.

When working in nonlocal environments, be careful that the alphanumeric UIC or rights identifiers that you use are valid for the environment.

### Qualifiers

#### **/DEVICE=device-spec**

Specifies the location of the quota file. SYSMAN validates the device specification. You can specify a logical name for *device-spec*. If you do, the logical name is translated in the target environment.

Without a device specification, SYSMAN uses the default disk on the target node. Unless you have set a default device with the SET PROFILE command, the default disk is the current device on the local node or the login default device on another node, depending on the established environment.

#### **/OVERDRAFT=value**

Specifies a positive integer that provides an overdraft value for the specified UIC. If omitted, the overdraft value defaults to the overdraft value in the entry for [0,0].

#### **/PERMQUOTA=value**

Specifies a positive integer that provides the quota for the specified UIC. If omitted, the permanent quota defaults to the value of the quota in the entry for [0,0].

### Description

The DISKQUOTA ADD command appends individual entries to a quota file on the specified disk. Note that the quota file must already exist and be enabled.

Unless you specify the permanent quota and overdraft values, SYSMAN applies the default values from the UIC entry [0,0]. You adjust UIC [0,0] with the DISKQUOTA MODIFY command.

## Example

```
SYSMAN> SET ENVIRONMENT/NODE=(NODE22,NODE21) ❶  
%SYSMAN-I-ENV, Current command environment:  
  Individual nodes: NODE22,NODE21  
  Username ALEXIS   will be used on nonlocal nodes.  
SYSMAN> SET PROFILE /PRIVILEGE=SYSPRV ❷  
SYSMAN> DISKQUOTA ADD [MKT,MORSE] /DEVICE=WORK1 -  
_SYSMAN> /PERMQUOTA=200 /OVERDRAFT=50 ❸  
SYSMAN> DISKQUOTA ADD PAYROLL /DEVICE=WORK1 /PERMQUOTA=1000 ❹
```

- ❶ Defines the management environment to be NODE22 and NODE21.
- ❷ Adds SYSPRV privilege to the user's current privileges in order to write to the quota file.
- ❸ Adds UIC [MKT,MORSE] to the quota file on the device named WORK1 on both NODE22 and NODE21, setting the permanent quota to 200 disk blocks and the overdraft limit to 50 disk blocks, for an absolute limit of 250 blocks.  
If the user name MORSE has a unique UIC on the system, you can enter the following command:

```
SYSMAN> DISKQUOTA ADD MORSE
```

- ❹ Adds an entry for the rights identifier PAYROLL. Any user holding the PAYROLL identifier can use this disk space.

# SYSMAN DISKQUOTA CREATE

---

## DISKQUOTA CREATE

Creates and enables a quota file for a disk volume that does not currently contain one.

Requires write (W) access to the volume's master file directory (MFD), plus one of the following items: SYSPRV privilege, a system UIC, or ownership of the volume.

### Format

DISKQUOTA CREATE

### Parameters

None.

### Qualifier

#### **/DEVICE=device-spec**

Specifies the disk volume on which to create a quota file. SYSMAN validates the device specification. A logical name may be specified for *device-spec*. If so, it is translated in the target environment.

Without a device specification, SYSMAN uses the default disk on the target node. Unless you have set a default device with the SET PROFILE command, the default disk is the current device on the local node or the login default device on another node, depending on the established environment.

### Description

The DISKQUOTA CREATE command creates a quota file for a volume that does not currently have one.

Only one quota file, [000000]QUOTA.SYS, can be present on any volume or volume set. As soon as you create a quota file, establish default values for quotas and overdrafts by adjusting UIC [0,0] with the DISKQUOTA MODIFY command. When a disk has existing files, use the DISKQUOTA REBUILD command to have SYSMAN update the quota file to contain current usage values.

---

#### **Note**

HP recommends that you do not create and enable a quota file on the system disk unless users are allowed to create files on that disk.

---

### Example

```
SYSMAN> SHOW ENVIRONMENT
%SYSMAN-I-ENV, Current command environment:
  Node NODE24 of local cluster
  Username ALEXIS      will be used on nonlocal nodes
```



## **SYSMAN DISKQUOTA CREATE**

```
SYSMAN> DO SHOW DEVICES
.
.
.
SYSMAN> DISKQUOTA CREATE /DEVICE=DJA31:
SYSMAN> DISKQUOTA MODIFY /DEVICE=DJA31: [0,0] -
_
SYSMAN> /PERMQUOTA=10000 /OVERDRAFT=100
```

The commands in this example sequence display the characteristics of the current management environment and verify the device name. Then they create a quota file on the disk DJA31 and set up default quota values.

## **SYSMAN DISKQUOTA DELETE**

---

### **DISKQUOTA DELETE**

Removes an entry from a quota file.

See the command `DISKQUOTA REMOVE` for more information. The `DISKQUOTA REMOVE` and `DISKQUOTA DELETE` commands perform the same function.

---

## **DISKQUOTA DISABLE**

Suspends the maintenance and enforcement of disk quotas on a volume in the current management environment; this applies to each node that has the disk mounted.

---

### **Caution**

---

To use the DISKQUOTA DISABLE command on a disk that has been mounted on multiple nodes in a cluster, you must first specify the nodes in the SET ENVIRONMENT command.

---

Requires SYSPRV privilege, a system UIC, or ownership of the volume.

### **Format**

DISKQUOTA DISABLE

### **Parameters**

None.

### **Qualifier**

#### **/DEVICE=device-spec**

Specifies a disk volume on which to disable a quota file. SYSMAN validates the device specification. A logical name may be specified for *device-spec*. If so, it is translated in the target environment.

Without a device specification, SYSMAN uses the default disk on the target node. Unless you have set a default device with the SET PROFILE command, the default disk is the current device on the local node or the login default device on another node, depending on the established environment.

### **Description**

The DISKQUOTA DISABLE command suspends quota operations on a volume. To permanently disable quotas on a device, disable the quotas with the DISKQUOTA DISABLE command and delete the file [000000]QUOTA.SYS. Otherwise, the system implicitly enables quotas when the disk is mounted, leaving invalid quota information.

If you enable the quota file later, enter the DISKQUOTA REBUILD command to update UIC entries and usage counts.

### **Examples**

1. SYSMAN> SET ENVIRONMENT/NODE=(AMANDA,BARRY)  
SYSMAN> DISKQUOTA DISABLE /DEVICE=DJA1:

These commands suspend quota enforcement on disk DJA1, which is mounted on nodes AMANDA and BARRY.

## SYSMAN DISKQUOTA DISABLE

```
2. SYSMAN> SET ENVIRONMENT/CLUSTER ❶
%SYSMAN-I-ENV, current command environment:
Clusterwide on local cluster
Username STEIN will be used on nonlocal nodes

SYSMAN> DO SHOW QUOTA/DISK=$6$dkd0:/USER=[0,0] ❷
%SYSMAN-I-OUTPUT, command execution on node WALTER
User [0,0] has 0 blocks used, 1000 available,
of 1000 authorized and permitted overdraft of 100 blocks on $6$DKD0
%SYSMAN-I-OUTPUT, command execution on node ARTOS2
User [0,0] has 0 blocks used, 1000 available,
of 1000 authorized and permitted overdraft of 100 blocks on $6$DKD0
%SYSMAN-I-OUTPUT, command execution on node ARTOS1
User [0,0] has 0 blocks used, 1000 available,
of 1000 authorized and permitted overdraft of 100 blocks on $6$DKD0
%SYSMAN-I-OUTPUT, command execution on node EXPERT
User [0,0] has 0 blocks used, 1000 available,
of 1000 authorized and permitted overdraft of 100 blocks on $6$DKD0

SYSMAN> DISKQUOTA DISABLE/DEVICE=$6$dkd0: ❸
SYSMAN> DO SHOW QUOTA/DISK=$6$dkd0:/USER=[0,0] ❹
%SYSMAN-I-OUTPUT, command execution on node WALTER
%SYSTEM-F-QFNOTACT, disk quotas not enabled on this volume
%SYSMAN-I-OUTPUT, command execution on node ARTOS2
%SYSTEM-F-QFNOTACT, disk quotas not enabled on this volume
%SYSMAN-I-OUTPUT, command execution on node ARTOS1
%SYSTEM-F-QFNOTACT, disk quotas not enabled on this volume
%SYSMAN-I-OUTPUT, command execution on node EXPERT
%SYSTEM-F-QFNOTACT, disk quotas not enabled on this volume
SYSMAN>
```

In this example, the disk \$6\$dkd0: has been mounted clusterwide.

- ❶ The SET ENVIRONMENT command sets the environment for all nodes in the cluster.
- ❷ The output of this DO SHOW QUOTA command shows that disk quotas are enabled over the cluster.
- ❸ The DISKQUOTA DISABLE command disables disk quotas over the entire cluster.
- ❹ The output of this DO SHOW QUOTA command shows that disk quotas have been disabled.

---

## **DISKQUOTA ENABLE**

Resumes quota enforcement on a disk volume in the current management environment; this applies to each node that has the disk mounted.

---

### **Caution**

---

To use the DISKQUOTA ENABLE command on a disk that has been mounted on multiple nodes in a cluster, you must first specify the nodes in the SET ENVIRONMENT command.

---

Requires SYSPRV privilege, a system UIC, or ownership of the volume.

### **Format**

DISKQUOTA ENABLE

### **Parameters**

None.

### **Qualifier**

#### **/DEVICE=device-spec**

Specifies a disk volume on which to enable the quota file. SYSMAN validates the device specification. A logical name may be specified for *device-spec*. If so, it is translated in the target environment.

Without a device specification, SYSMAN uses the default disk on the target node. Unless you have set a default device with the SET PROFILE command, the default disk is the current device on the local node or the login default device on another node, depending on the established environment.

### **Description**

The DISKQUOTA ENABLE command reinstates the enforcement of quotas on a volume that had been suspended with the DISKQUOTA DISABLE command. Whenever you enable quotas on a volume, use the DISKQUOTA REBUILD command to update UIC entries and usage counts.

### **Examples**

1. SYSMAN> SET ENVIRONMENT/NODE=(NODE21,NODE22)  
SYSMAN> DISKQUOTA ENABLE  
SYSMAN> DISKQUOTA REBUILD

The DISKQUOTA ENABLE command in this example resumes quota enforcement on the default disk DJA12, which is mounted on NODE21 and NODE22. The DISKQUOTA REBUILD command updates the quota file, correcting quotas and adding any new entries.

## SYSMAN DISKQUOTA ENABLE

```
2. SYSMAN> SET ENVIRONMENT/CLUSTER ❶
%SYSMAN-I-ENV, current command environment:
Clusterwide on local cluster
Username STEIN will be used on nonlocal nodes

SYSMAN> DO SHOW QUOTA/DISK=$6$dkd0:/USER=[0,0] ❷
%SYSMAN-I-OUTPUT, command execution on node WALTER
%SYSTEM-F-QFNOTACT, disk quotas not enabled on this volume
%SYSMAN-I-OUTPUT, command execution on node ARTOS2
%SYSTEM-F-QFNOTACT, disk quotas not enabled on this volume
%SYSMAN-I-OUTPUT, command execution on node ARTOS1
%SYSTEM-F-QFNOTACT, disk quotas not enabled on this volume
%SYSMAN-I-OUTPUT, command execution on node EXPERT
%SYSTEM-F-QFNOTACT, disk quotas not enabled on this volume

SYSMAN> DISKQUOTA ENABLE/DEVICE=$6$dkd0: ❸
SYSMAN> DO SHOW QUOTA/DISK=$6$dkd0:/USER=[0,0] ❹
%SYSMAN-I-OUTPUT, command execution on node WALTER
User [0,0] has 0 blocks used, 1000 available,
of 1000 authorized and permitted overdraft of 100 blocks on $6$DKD0
%SYSMAN-I-OUTPUT, command execution on node ARTOS2
User [0,0] has 0 blocks used, 1000 available,
of 1000 authorized and permitted overdraft of 100 blocks on $6$DKD0
%SYSMAN-I-OUTPUT, command execution on node ARTOS1
User [0,0] has 0 blocks used, 1000 available,
of 1000 authorized and permitted overdraft of 100 blocks on $6$DKD0
%SYSMAN-I-OUTPUT, command execution on node EXPERT
User [0,0] has 0 blocks used, 1000 available,
of 1000 authorized and permitted overdraft of 100 blocks on $6$DKD0
```

In this example, the disk \$6\$dkd0: has been mounted clusterwide.

- ❶ The SET ENVIRONMENT command sets the environment for all nodes in the cluster.
- ❷ The output of this DO SHOW QUOTA command shows that disk quotas have not been enabled.
- ❸ The DISKQUOTA ENABLE command enables disk quotas over the entire cluster.
- ❹ The output of this DO SHOW QUOTA command shows that disk quotas have been enabled over the cluster.

---

## **DISKQUOTA MODIFY**

Changes an entry in a quota file or adjusts default values for quotas and overdrafts. If a new quota limit is less than the current usage count, SYSMAN issues a warning message before it implements the new quota.

Requires write (W) access to the quota file.

### **Format**

DISKQUOTA MODIFY owner

### **Parameter**

#### **owner**

Specifies the user identification code (UIC) or rights identifier. You can specify the UIC in numeric or alphanumeric format. For complete information about UIC specification, see the *HP OpenVMS Guide to System Security*.

Rights identifiers are granted with the Authorize utility and use an ID format rather than a UIC format. For a complete description of rights identifiers, see the *HP OpenVMS Programming Concepts Manual*.

When working in nonlocal environments, make sure that the alphanumeric UIC or rights identifiers that you use are valid for the environment.

### **Qualifiers**

#### **/DEVICE=device-spec**

Specifies the disk volume that contains the quota file. SYSMAN validates the device specification. A logical name may be specified for *device-spec*. If so, it is translated in the target environment.

Without a device specification, SYSMAN uses the default disk on the target node. Unless you have set a default device with the SET PROFILE command, the default disk is the current device on the local node or the login default device on another node, depending on the established environment.

#### **/OVERDRAFT=value**

Specifies a positive integer that provides an overdraft value for the specified UIC. If you omit a value, the overdraft value defaults to the overdraft value in the entry for [0,0].

#### **/PERMQUOTA=value**

Specifies a positive integer that provides the quota for the specified UIC. If you omit a value, the permanent quota defaults to the value of the quota in the entry for [0,0].

## **SYSMAN DISKQUOTA MODIFY**

### **Description**

The DISKQUOTA MODIFY command changes values in a quota file for the disk named in the device specification. If you establish a quota limit that is less than the current usage count, a user can still log in and out, but cannot create files.

After creating a quota file, use the DISKQUOTA MODIFY command to set default values for quotas and overdrafts. UIC [0,0] sets the default permanent quota and overdraft values for a quota file, so you must change the entry [0,0] to values appropriate for your installation. Unless you specify quota and overdraft values when adding a file entry, SYSMAN applies these defaults to UIC entries.

### **Examples**

1. SYSMAN> SET ENVIRONMENT/NODE=NODE21  
SYSMAN> DISKQUOTA MODIFY /DEVICE=DUA12: [0,0] -  
\_SYSMAN> /PERMQUOTA=3000 /OVERDRAFT=300

The commands in this example edit the entry for UIC [0,0] in the quota file on DUA12, which is located on NODE21.

2. SYSMAN> DISKQUOTA MODIFY /DEVICE=SYS\$DISK1 [TTD,DAVIS] -  
\_SYSMAN> /PERMQUOTA=900

This command sets the permanent quota for UIC [TTD,DAVIS] to 900 blocks, while making no change to the overdraft limit. SYSMAN modifies the quota file that is located on disk SYS\$DISK1 in the current environment.

If the user name DAVIS has a unique UIC on the system, you can enter the following command:

```
SYSMAN> DISKQUOTA MODIFY DAVIS/PERMQUOTA=900
```



---

## **DISKQUOTA REBUILD**

Updates a quota file, adding new UICs and correcting usage counts for each user on the volume.

Requires write (W) access to the quota file, plus one of the following items: SYSPRV privilege, a system UIC, or ownership of the volume.

### **Format**

DISKQUOTA REBUILD

### **Parameters**

None.

### **Qualifier**

#### **/DEVICE=device-spec**

Specifies the disk volume that contains the quota file. SYSMAN validates the device specification and translates any logical name in the target environment before rebuilding the file.

Without a device specification, SYSMAN uses the default disk on the target node. Unless you have set a default device with the SET PROFILE command, the default disk is the current device on the local node or the login default device on another node, depending on the established environment.

### **Description**

The DISKQUOTA REBUILD command reads the disk, recalculates usage counts for all existing entries in QUOTA.SYS, and adds new entries. It sets quota and overdraft values to the defaults set in UIC [0,0] if the entry did not previously exist. While the DISKQUOTA REBUILD command is executing, file activity on the volume is frozen. No files can be created, deleted, extended, or truncated.

Use the DISKQUOTA REBUILD command in the following circumstances:

- After creating a quota file on a volume with existing files.
- When the quota file has been enabled after a period of being disabled. The command corrects the usage counts and adds any new UICs.

### **Example**

```
SYSMAN> SET ENVIRONMENT /NODE=NODE21  
SYSMAN> SET PROFILE /PRIVILEGE=SYSPRV  
SYSMAN> DISKQUOTA ENABLE /DEVICE=DUA226:  
SYSMAN> DISKQUOTA REBUILD /DEVICE=DUA226:
```

These commands enable the quota file and reconstruct the usage counts for all entries on disk DUA226, which is located on node NODE21.

# SYSMAN DISKQUOTA REMOVE

---

## DISKQUOTA REMOVE

Removes an entry from a quota file.

Requires write (W) access to the quota file.

### Format

```
DISKQUOTA REMOVE owner
```

### Parameter

#### **owner**

Specifies the user identification code (UIC) or rights identifier. You can specify the UIC in numeric or alphanumeric format. For complete information about UIC specification, see the *HP OpenVMS Guide to System Security*.

Rights identifiers are granted with the Authorize utility and use an ID format rather than a UIC format. For more information about rights identifiers, see the *HP OpenVMS Programming Concepts Manual*.

When working in nonlocal environments, be careful that the alphanumeric UIC or rights identifiers that you use are valid for the environment.

### Qualifier

#### **/DEVICE=device-spec**

Specifies the disk volume containing the quota file. SYSMAN validates the device specification and translates any logical name in the target environment before deleting the UIC entry.

Without a device specification, SYSMAN uses the default disk on the target node. Unless you have set a default device with the SET PROFILE command, the default disk is the current device on the local node or the login default device on another node, depending on the established environment.

### Description

The DISKQUOTA REMOVE command eliminates the specified UIC from the quota file on the named device.

If the usage count for the UIC is not zero, files remain on disk and the user can still log in, but any attempt to create or extend files will fail.

The UIC [0,0] entry cannot be removed.

### Example

```
SYSMAN> SET ENVIRONMENT/NODE=MARS
SYSMAN> SHOW PROFILE
%SYSMAN-I-DEFDIR, Default directory on node MARS -- WORK2:[CASEY]
%SYSMAN-I-DEFPRIV, Process privileges on node MARS --
    TMPMGX
    OPER
    NETMBX
    SYSPRV
```

## **SYSMAN DISKQUOTA REMOVE**

```
SYSMAN> DISKQUOTA REMOVE /DEVICE=DUA45: [TTD,DAVIS]
```

These commands remove UIC [TTD,DAVIS] from the quota file for disk DUA45, which is located on node MARS.

# SYSMAN DISKQUOTA SHOW

---

## DISKQUOTA SHOW

Displays quotas, overdrafts, and usage counts.

Requires no additional privileges to display your own quota, overdraft, and usage count, but otherwise requires read (R) access to the quota file.

### Format

DISKQUOTA SHOW owner

### Parameter

#### owner

Specifies the user identification code (UIC) or rights identifier. You can specify the UIC in numeric or alphanumeric format. For complete information about UIC specification, see the *HP OpenVMS Guide to System Security*.

Rights identifiers are granted with the Authorize utility and use an ID format rather than a UIC format. For a complete description of rights identifiers, see the *HP OpenVMS Programming Concepts Manual*.

You can use an asterisk wildcard character (\*) to specify the quota entry as follows:

| Command                 | Description   |
|-------------------------|---|
| DISQUOTA SHOW CJ        | Show user CJ (if CJ has a unique UIC on the system) |
| DISKQUOTA SHOW [TTD,CJ] | Show user CJ in group TTD                           |
| DISKQUOTA SHOW [TTD,*]  | Show all users in group TTD                         |
| DISKQUOTA SHOW *        | Show all entries                                    |

### Qualifiers

#### /DEVICE=device-spec

Specifies the disk volume containing the quota file. DISKQUOTA validates device specification and translates any logical name in the target environment before displaying UIC entries.

Without a device specification, SYSMAN uses the default disk on the target node. Unless you have set a default device with the SET PROFILE command, the default disk is the current device on the local node or the login default device on another node, depending on the established environment.

#### /OUTPUT[=filespec]

Directs output to the specified file. Without a file specification, /OUTPUT defaults to SYSMAN.LIS in the current directory on the local node where you are running SYSMAN.

### Example

```
SYSMAN> DISKQUOTA SHOW [ACCT,*]
```

This command displays quotas, overdrafts, and usage counts for all users in group ACCT on the default disk.

## DO

Executes a DCL command or DCL command procedure on all nodes in the current management environment.

Requires the privileges of the DCL command being executed.

### Format

DO [command-line]

### Parameter

#### **command-line**

Specifies a command string that SYSMAN passes to the command line interface (CLI) for execution.

The command DO RUN SYS\$SYSTEM:SYSMAN [SYSMAN-command] is not supported. Instead, follow these steps:

1. Enter RUN SYS\$SYSTEM:SYSMAN at the dollar (\$) prompt.
2. At the SYSMAN> prompt, set the environment to the selected node or nodes with the SET ENVIRONMENT command.
3. Enter a SYSMAN command at the SYSMAN> prompt.

For complete information about DCL command syntax, see the *HP OpenVMS DCL Dictionary*.

### Qualifiers

#### **/CONFIRM**

Verifies that you want to perform a DO command on each node you have specified with the SYSMAN command SET ENVIRONMENT.

When you use the /CONFIRM qualifier, the system prompts you as follows:

Execute command for node <nodename>? [N]:

The following responses are valid:

|      |                                     |                                     |     |
|------|-------------------------------------|-------------------------------------|-----|
| YES  | NO                                  | QUIT                                | ALL |
| TRUE | FALSE                               | <input type="text" value="Ctrl/Z"/> |     |
| 1    | 0                                   | <input type="text" value="Ctrl/C"/> |     |
|      | <input type="text" value="Return"/> |                                     |     |

#### **Usage Notes**

- Affirmative answers are YES, TRUE, and 1.
- Negative answers are NO, FALSE, 0, and pressing the Return key.
- You can use any combination of uppercase and lowercase letters for word responses.
- You can abbreviate word responses to one or more letters (for example, T, TR, or TRU for TRUE), but these abbreviations must be unique.
- Entering QUIT or pressing Ctrl/C or Ctrl/Z indicates that you want to stop processing the command at that point.

## **SYSMAN DO**

- When you enter ALL, the command continues to process, but the system displays no further prompts.
- If you type a response that is not valid, SYSMAN issues an error message and redisplay the prompt.

### **/OUTPUT[=filespec]**

Records output from the command in the specified file, which is located on the node from which you are executing SYSMAN. Position the qualifier immediately after the DO command. The default file specification is SYSMAN.LIS in the current device and directory. SYSMAN prefaces output with the message “%SYSMAN-I-OUTPUT, command execution on node xxxxxx.”

### **/PAUSE**

Controls the rate at which the system displays information. Using the /PAUSE qualifier causes the system to display information about one node at a time; the system prompts you to press Return when you are ready to display information about the next node.

## **Description**

The DO command executes the accompanying DCL command or DCL command procedure on all nodes in the current environment. Each DO command executes as an independent process, so no process context is retained between DO commands. For this reason, you must express all DCL commands in a single command string, and you cannot run a program that expects input.

In an OpenVMS Cluster environment, SYSMAN executes the commands sequentially on all nodes in the cluster. Each command executes completely before SYSMAN sends it to the next node in the environment. Any node that is unable to execute the command returns an error message. SYSMAN displays an error message if the timeout period expires before the node responds.

The system cannot display output returned from a command of more than 2048 characters without concatenation.

Three exceptions to be aware of when using the DO command in clusters are the following ones:

- In a multi-architecture heterogeneous cluster running OpenVMS VAX, Alpha, and Integrity servers, some uses of the DO command may require special handling. For example, if you are installing images that are named differently in each architecture, you can still use the DO command if you create logical name tables for VAX, Alpha, and Integrity server nodes. See the example sequence that follows this description for an example.
- Some DCL commands, such as MOUNT/CLUSTER or SET QUORUM/CLUSTER, operate clusterwide by design. It is best to avoid using these kinds of commands with the DO command in SYSMAN when the environment is set to cluster. As alternatives, you could leave SYSMAN temporarily with the SPAWN command and execute these commands in DCL, or you could define the environment to be a single node within the cluster. Similarly, operations on clusterwide logical names and tables operate clusterwide by design.

- Make sure that if you redefine the logical DCLTABLES, you do so in SYLOGICALS.COM, not in SYSTARTUP\_VMS.COM or elsewhere. Otherwise, you will receive a command interpreter failure when executing a DO command on a remote node.

## Examples

1. SYSMAN> SET ENVIRONMENT/CLUSTER/NODE=NODE21  
SYSMAN> DO/OUTPUT SHOW DEVICE

The first command in this example defines the management environment to be the cluster where NODE21 is a member. The second command executes a DCL command on each node in the cluster. Output goes to the file SYSMAN.LIS rather than to the terminal.

2. SYSMAN> SET ENVIRONMENT/NODE=NODE21  
SYSMAN> SET PROFILE /DEFAULT=[CJ.PROGRAMS] -  
SYSMAN> /PRIVILEGES=NOSYSRV  
SYSMAN> DO/OUTPUT @PROCESS\_INFO

The commands in this example define the environment as a single node and adjust the current privileges and directory. The DO command executes the command procedure PROCESS\_INFO.COM, located in directory [CJ.PROGRAMS] and writes any output to SYSMAN.LIS in the directory from which SYSMAN is running.

3. \$ CREATE/NAME TABLE/PARENT=LNMS\$SYSTEM\_DIRECTORY SYSMAN\$NODE TABLE  
\$ DEFINE/TABLE=SYSMAN\$NODE\_TABLE ALPHA NODES NODE21,NODE22,NODE23  
\$ DEFINE/TABLE=SYSMAN\$NODE\_TABLE VAX\_NODES NODE24,NODE25,NODE26  
\$ RUN SYS\$SYSTEM:SYSMAN  
SYSMAN> SET ENVIRONMENT/NODE=ALPHA\_NODES  
%SYSMAN-I-ENV, current command environment:  
    Individual nodes: NODE21,NODE22,NODE23  
    Username BOUCHARD will be used on nonlocal nodes  
  
SYSMAN> DO INSTALL REPLACE SYS\$LIBRARY:DCLTABLES.EXE  
%SYSMAN-I-OUTPUT, command execution on node NODE21  
%SYSMAN-I-OUTPUT, command execution on node NODE22  
%SYSMAN-I-OUTPUT, command execution on node NODE23  
SYSMAN> DO INSTALL REPLACE SYS\$SYSTEM:COM\_FORTRAN.EXE  
%SYSMAN-I-OUTPUT, command execution on node NODE21  
%SYSMAN-I-OUTPUT, command execution on node NODE22  
%SYSMAN-I-OUTPUT, command execution on node NODE23  
  
SYSMAN> SET ENVIRONMENT/NODE=VAX\_NODES  
%SYSMAN-I-ENV, current command environment:  
    Individual nodes: NODE24,NODE25,NODE26  
    Username BOUCHARD will be used on nonlocal nodes  
  
SYSMAN> DO INSTALL REPLACE SYS\$LIBRARY:DCLTABLES.EXE  
%SYSMAN-I-OUTPUT, command execution on node NODE24  
%SYSMAN-I-OUTPUT, command execution on node NODE25  
%SYSMAN-I-OUTPUT, command execution on node NODE26  
SYSMAN> DO INSTALL REPLACE SYS\$SYSTEM:FORTRAN\$MAIN.EXE  
%SYSMAN-I-OUTPUT, command execution on node NODE24  
%SYSMAN-I-OUTPUT, command execution on node NODE25  
%SYSMAN-I-OUTPUT, command execution on node NODE26

This example shows how you can define logical names for VAX, Alpha, and Integrity server nodes in a multi-architecture heterogeneous cluster, so that you can use the DO command to install architecture-specific images.

## SYSMAN DO

```
4. $ RUN SYS$SYSTEM:SYSMAN
SYSMAN> SET ENVIRONMENT/CLUSTER
%SYSMAN-I-ENV, current command environment:
    Clusterwide on local cluster
    Username STEIN will be used on nonlocal nodes
SYSMAN> DO/CONFIRM SHOW TIME
Execute command for node EXPERT? [N]: Y 
%SYSMAN-I-OUTPUT, command execution on node EXPERT
    22-MAR-2002 09:40:28

Execute command for node MODERN? [N]: Y 
%SYSMAN-I-OUTPUT, command execution on node MODERN
    22-MAR-2002 09:40:56

Execute command for node IMPOSE? [N]: N 
Execute command for node ADU26A? [N]: Y 
.
.
.
```

The commands in this example show how to control whether the system displays time for each node in a cluster.

```
5. SYSMAN> DO/PAUSE SHOW TIME
%SYSMAN-I-OUTPUT, command execution on node EXPERT
    22-MAR-2002 09:40:13

Press return to continue 
%SYSMAN-I-OUTPUT, command execution on node MODER
    22-MAR-2002 09:40:41

Press return to continue 
%SYSMAN-I-OUTPUT, command execution on node IMPOSE
    22-MAR-2002 09:39:46

Press return to continue 
.
.
.
```

The commands in this example show how you can control the rate at which information is displayed on your system.



---

## DUMP\_PRIORITY ADD (Alpha and Integrity servers)

On Alpha and Integrity servers, adds an entry to the System Dump Priority registry file.

The registry data file is the permanent database that survives reboots. It is loaded into memory during a boot. (You can use the DUMP\_PRIORITY LOAD command at any time to load the contents of this file into memory.)

When you add an entry to the registry file, you must specify both the process name and UIC. If you attempt to add an entry that already exists, the system displays the following message: "SMI-I-SDPDUPIGN, duplicate record creation ignored."

### How Dump Priority Works

BUGCHECK uses the loaded contents of the System Dump Priority registry to select priority processes to dump early on during a selective dump. Adding a dump priority for a process increases the likelihood that the process will be included in a dump, if there is insufficient space for all processes. (The ADD command only adds an entry to the System Dump Priority registry permanent file. For BUGCHECK to be able to see the entry, you must also enter a DUMP\_PRIORITY LOAD command.)

BUGCHECK also keeps its own in-memory hardcoded list of priority processes, which are always treated as priority processes, even if the System Dump Priority registry is empty. These processes are the following:

| Process Name | UIC   |
|--------------|-------|
| MSCPmount    | [1,4] |
| AUDIT_SERVER | [1,4] |
| NETACP       | [1,4] |
| NET\$ACP     | [1,3] |
| REMACP       | [1,3] |
| LES\$ACP     | [1,4] |

Note that you cannot see, change, or delete these default processes with DUMP\_PRIORITY commands.

If you enter a process into the System Dump Priority registry, that process is dumped earlier, because user-specified priority processes are dumped before processes that are hardcoded into BUGCHECK.

Keep in mind that BUGCHECK keeps track of the processes that have been dumped, so that no process is dumped twice.

### Format

```
DUMP_PRIORITY ADD process-name /UIC=uic [/WILD_CARD]
```

### Parameter

#### **process-name**

The exact name of the process. If the process name is mixed-case or includes spaces or any other nonstandard OpenVMS characters, you must enclose it in double quotes; for example, "My Process".

## SYSMAN DUMP\_PRIORITY ADD (Alpha and Integrity servers)

You can use wildcard characters (\* and %). Because these characters are valid characters in any process name, you must include the wildcard flag /WILD\_CARD. Setting the /WILD\_CARD flag for a specific process entry tells BUGCHECK to treat the asterisk (\*) and percent-sign (%) as wild cards.

### Qualifiers

#### **/INFORMATIONAL (default)**

#### **/NOINFORMATIONAL**

On Alpha and Integrity servers, allows you to control the output of informational messages, for example, in command procedures. These qualifiers allow you to suppress or reinstate the display of informational messages.

Suppressing messages can also be useful when you are running in a software installation environment and want to avoid the display of informational messages. The default is /INFORMATIONAL.

#### **/UIC**

Specifies the UIC of the entry to add. You must enclose the UIC in brackets ([ ]). You can specify the /UIC with an octal number (for example, [377,377]) or in the identifier form (for example, [SYSTEM] or [VMS,USER]).

Wildcards are allowed as follows:

| Wildcard Example | Description  |
|------------------|--|
| /UIC = [*]       | To select processes with the specified name in any UIC.                  |
| /UIC = [group,*] | To select processes with the specified name in the group called "group". |
| /UIC = [100,*]   | To select processes with the specified name in group 100>.               |

---

#### **Note**

---

You cannot use wildcards within identifier names or within UIC numbers. For example, /UIC=[USER\*,\*] or /UIC=[17\*,100] are not allowed.

---

#### **/WILD\_CARD**

#### **/NOWILD\_CARD**

Specifies whether or not wildcard characters in the process name are to be treated as wildcards. Note, however, that you cannot add the same process name and UIC combination both with and without the /WILD\_CARD qualifier. If the combination has already been specified, use the DUMP\_PRIORITY MODIFY command to change the wildcard setting.

The /WILD\_CARD setting affects only the process name. Wildcards are always allowed in the UIC.

## SYSMAN DUMP\_PRIORITY ADD (Alpha and Integrity servers)

### Example

```
SYSMAN> DUMP_PRIORITY ADD "MyPro*"/UIC=[*]/WILD_CARD
SYSMAN> DUMP_PRIORITY LIST
%SYSMAN-I-OUTPUT, command execution on node VMS73
```

| Process name | UIC | Wild Card |
|--------------|-----|-----------|
| MyPro*       | [*] | Y         |

The first command in this example adds an entry to the System Dump Priority registry. The process name is "MyPro\*" with any UIC, and BUGCHECK will treat the asterisk (\*) in MyPro\* as a wildcard when the registry is loaded into memory.

BUGCHECK treats the UIC wildcard asterisk (\*) as a wildcard, even if you do not specify the /WILD\_CARD qualifier on the command line.

The Y under the Wild Card heading means that the /WILD\_CARD qualifier has been specified on the command line and a wildcard has been specified in the process name.

## **SYSMAN DUMP\_PRIORITY LIST (Alpha and Integrity servers)**

---

### **DUMP\_PRIORITY LIST (Alpha and Integrity servers)**

On Alpha and Integrity servers, lists the contents of the System Dump Priority registry file.

#### **Format**

DUMP\_PRIORITY LIST

#### **Parameters**

None.

#### **Qualifiers**

None.

#### **Example**

```
SYSMAN> DUMP_PRIORITY LIST
%SYSMAN-I-OUTPUT, command execution on node VMS73
Process name    UIC                               Wild Card
MSCPmount       [SYSTEM]                                   N
NETACP         [SYSTEM]                                   N
NET$ACP        [1,3]                                     N
REMACP         [1,3]                                     N
LES$ACP        [SYSTEM]                                   N
SYSMAN>
```

The command in this example produces a list of the contents of the System Dump Priority registry, including the process name and UIC of each entry. The list also shows N under the Wild Card heading, which indicates that BUGCHECK is to match the process name exactly during a crash. (However, N or Y under Wild Card is important only if the the process name contains one or more wildcard characters.)

## **DUMP\_PRIORITY LOAD (Alpha and Integrity servers)**

On Alpha and Integrity servers, loads the contents of the System Dump Priority registry file into memory for BUGCHECK to use.

### **Format**

DUMP\_PRIORITY LOAD

### **Parameters**

None.

### **Qualifiers**

None.

### **Example**

```
SYSMAN> DUMP_PRIORITY SHOW
%SMI-F-SDPNOTLOAD, System Dump Priority not loaded
SYSMAN> DUMP_PRIORITY LOAD
SYSMAN> DUMP_PRIORITY SHOW
%SYSMAN-I-OUTPUT, command execution on node VMS73
Process name    UIC                               Wild Card
MSCPmount       [SYSTEM]                               N
NETACP         [SYSTEM]                               N
NET$ACP        [00001,000003]                         N
REMACP         [00001,000003]                         N
LES$ACP        [SYSTEM]                               N
SYSMAN>
```

The first command in the example displays the message that the System Dump Priority registry file has not been loaded into memory. The second command loads the registry file into memory for BUGCHECK to use, and the third command displays the contents of the registry file that have been loaded into memory.

## SYSMAN DUMP\_PRIORITY MODIFY (Alpha and Integrity servers)

---

### DUMP\_PRIORITY MODIFY (Alpha and Integrity servers)

On Alpha and Integrity servers, modifies an entry in the System Dump Priority registry file.

#### Format

```
DUMP_PRIORITY MODIFY process-name /UIC=uc  
[ /NEWUIC=newuic ][ /WILD_CARD ]
```

#### Parameter

##### **process-name**

The exact name of the process. If the process name is mixed-case or includes spaces or any other nonstandard OpenVMS characters, you must enclose the process name in double quotes; for example, "My Process". Also, when you enter a DUMP\_PRIORITY MODIFY command, be sure to enter the process name *exactly* as it is displayed when you enter a DUMP\_PRIORITY LIST command, because the system searches for that process name to find the entry to modify.

If you attempt to modify an existing entry where the modification can result in a duplicate, the system displays the following message: "SMI-I-SDPDUIGN, duplicate record creation ignored." The existing record is not removed.

#### Qualifiers

##### **/INFORMATIONAL (default)**

##### **/NOINFORMATIONAL**

On Alpha and Integrity servers, allows you to control the output of informational messages, for example, in command procedures. These qualifiers allow you to suppress or reinstate the display of informational messages.

Suppressing messages can also be useful when you are running in a software installation environment and want to avoid the display of informational messages. The default is /INFORMATIONAL.

##### **/UIC**

Specifies the UIC of the entry in the registry that you want to modify. The UIC and process name together make the entry unique. Specify the UIC as it is displayed when you enter the DUMP\_PRIORITY LIST command.

##### **/NEWUIC**

Modifies the UIC of an entry that you specify by its process name and current UIC. You can specify the /NEWUIC with an octal number (for example, [377,377]) or in the identifier form (for example, [SYSTEM] or [VMS,USER]).

Wildcards are allowed as follows:

---

| Wildcard Example | Description  |
|------------------|--|
| /UIC = [*]       | To select processes with the specified name in any UIC.                  |
| /UIC = [group,*] | To select processes with the specified name in the group called "group". |

## SYSMAN DUMP\_PRIORITY MODIFY (Alpha and Integrity servers)

| Wildcard Example            | Description  |
|-----------------------------|--|
| <code>/UIC = [100,*]</code> | To select processes with the specified name in group 100>. |

### Note

You cannot use wildcards within identifier names or within UIC numbers. For example, `/UIC=[USER*,*]` or `/UIC=[17*,100]` are not allowed.

### **/WILD\_CARD** **/NOWILD\_CARD**

The `/WILD_CARD` qualifier, used together with the `MODIFY` command, modifies the wildcard setting on the entry that you are modifying. If you omit `/WILD_CARD`, the current wildcard setting is retained.

### Example

```

SYSMAN> DUMP_PRIORITY LIST

%SYSMAN-I-OUTPUT, command execution on node VMS73

Process name   UIC                               Wild Card
MSCP*          [SYSTEM]                           Y
NETACP         [SYSTEM]                           N

SYSMAN> DUMP_PRIORITY MODIFY "MSCP*" /UIC=[SYSTEM] /NEWUIC=[TEST] /NOWILD_CARD ❶
SYSMAN> DUMP_PRIORITY LIST

%SYSMAN-I-OUTPUT, command execution on node VMS73

Process name   UIC                               Wild Card
MSCP*          [TEST]                             N
NETACP         [SYSTEM]                           N

SYSMAN> DUMP_PRIORITY MODIFY "MSCP*" /UIC=[TEST] /NEWUIC=[*] ❷
SYSMAN> DUMP_PRIORITY LIST

%SYSMAN-I-OUTPUT, command execution on node VMS73

Process name   UIC                               Wild Card
MSCP*          [*]                                N
NETACP         [SYSTEM]                           N

SYSMAN> DUMP_PRIORITY MODIFY "MSCP*" /UIC=[*] /WILD_CARD ❸

%SYSMAN-I-OUTPUT, command execution on node VMS73

Process name   UIC                               Wild Card
MSCP*          [*]                                Y
NETACP         [SYSTEM]                           N

```

Refer to the numbers at the end of the `DUMP_PRIORITY MODIFY` command lines in the example, which correspond to the numbered explanations that follow. (The `DUMP_PRIORITY LIST` command, after each `MODIFY` command, displays the results of the modifications in the System Dump Priority registry.)

- ❶ The first `DUMP_PRIORITY MODIFY` command modifies the `MSCP*` entry with the current UIC `[SYSTEM]` the new UIC `[TEST]`. It also changes the `/WILD_CARD` flag to `/NOWILD_CARD`. If the System Dump Priority registry is then loaded into memory, `BUGCHECK` will not treat the asterisk (\*) in the

## **SYSMAN DUMP\_PRIORITY MODIFY (Alpha and Integrity servers)**

process name as a wildcard, but rather, will do an exact character match of MSCP\*.

- ② The second DUMP\_PRIORITY MODIFY command modifies only the UIC of the entry to [\*]. Omitting the /[NO]WILD\_CARD qualifier will leave the current setting unchanged.
- ③ The third DUMP\_PRIORITY MODIFY command modifies only the process name wildcarding flag with the /WILD\_CARD qualifier.



---

## DUMP\_PRIORITY REMOVE (Alpha Integrity servers)

On Alpha and Integrity servers, removes a record from the System Dump Priority registry file.

### Format

DUMP\_PRIORITY REMOVE process-name /UIC=uic

### Parameter

#### **process-name**

The exact name of the process. If the process name is mixed-case or includes spaces or any other nonstandard OpenVMS characters, you must enclose the process name in double quotes; for example, "My Process".

Also, when you enter a DUMP\_PRIORITY REMOVE command, be sure to enter the process name *exactly* as it is displayed when you enter a DUMP\_PRIORITY LIST command, because the system searches for that process name to find the entry to remove. If you attempt to remove a nonexistent entry from the System Dump Priority registry, the system displays the following message: "SMI-I-SDPRNOTREM, no record removed." When the system cannot find the entry to modify, it displays the following message: "SMI\_F\_SDPNOTFOUND, system dump priority record not found."

### Qualifier

#### **/INFORMATIONAL (default)**

#### **/NOINFORMATIONAL**

On Alpha and Integrity servers, allows you to control the output of informational messages, for example, in command procedures. These qualifiers allow you to suppress or reinstate the display of informational messages.

Suppressing messages can also be useful when you are running in a software installation environment and want to avoid the display of informational messages. The default is /INFORMATIONAL.

#### **/UIC**

Specifies the UIC of the entry in the registry that you want to remove. The UIC and process name together make the entry unique. Specify the UIC as it is displayed when you enter the DUMP\_PRIORITY LIST command.

### Example

```
SYSMAN> DUMP_PRIORITY LIST
%SYSMAN-I-OUTPUT, command execution on node VMS73
Process name   UIC                               Wild Card
MSCPmount      [SYSTEM]                               N
NETACP        [SYSTEM]                               N
NET$ACP       [1,3]                                  N
REMACP        [1,3]                                  N
LES$ACP       [SYSTEM]                               N
```

## SYSMAN DUMP\_PRIORITY REMOVE (Alpha Integrity servers)

```
SYSMAN> DUMP_PRIORITY REMOVE "MSCPmount"/UIC=[SYSTEM]
SYSMAN> DUMP_PRIORITY LIST
%SYSMAN-I-OUTPUT, command execution on node VMS73
Process name      UIC                      Wild Card
NETACP            [SYSTEM]                 N
NET$ACP          [1,3]                    N
REMACP           [1,3]                    N
LES$ACP          [SYSTEM]                 N
```

The DUMP\_PRIORITY REMOVE command in this example removes the entry MSCPmount with the UIC of [SYSTEM] from the System Dump Priority registry file. (The process name MSCPmount is enclosed in quotes because it is mixed-case.)

## **DUMP\_PRIORITY SHOW (Alpha and Integrity servers)**

On Alpha and Integrity servers, lists the contents of the in-memory copy of the System Dump Priority registry file.

### **Format**

DUMP\_PRIORITY SHOW

### **Parameters**

None.

### **Qualifiers**

None.

### **Example**

```
SYSMAN> DUMP_PRIORITY SHOW
%SMI-F-SDPNOTLOAD, System Dump Priority not loaded

SYSMAN> DUMP_PRIORITY LOAD
SYSMAN> DUMP_PRIORITY SHOW
%SYSMAN-I-OUTPUT, command execution on node VMS73
Process name    UIC                               Wild Card
MSCPmount       [SYSTEM]                             N
NETACP         [SYSTEM]                             N
NET$ACP        [00001,000003]                       N
REMACP         [00001,000003]                       N
LES$ACP        [SYSTEM]                             N
SYSMAN>
```

The first DUMP\_PRIORITY SHOW command in the example results in the display indicating that the System Dump Priority registry file has not been loaded into memory. The second DUMP\_PRIORITY SHOW command, which follows a LOAD command, displays an in-memory copy of the file.

## **SYSMAN DUMP\_PRIORITY UNLOAD (Alpha and Integrity servers)**

---

### **DUMP\_PRIORITY UNLOAD (Alpha and Integrity servers)**

On Alpha and Integrity servers, clears the in-memory copy of the System Dump Priority registry file.

#### **Format**

DUMP\_PRIORITY UNLOAD

#### **Parameters**

None.

#### **Qualifiers**

None.

#### **Example**

```
SYSMAN> DUMP_PRIORITY UNLOAD  
SYSMAN> DUMP_PRIORITY SHOW  
%SMI-F-SDPNOTLOAD, System Dump Priority not loaded
```

Following a DUMP\_PRIORITY UNLOAD command, the DUMP\_PRIORITY SHOW command in this example displays the message that the System Dump Priority registry no longer has an in-memory copy of the file.

---

**EXIT**

Terminates the SYSMAN session and returns control to the DCL command level. Any profile changes, established on the local node with the command SET PROFILE, are restored to their values at the time SYSMAN was invoked. You can also press Ctrl/Z to exit at any time.

**Format**

EXIT

**Parameters**

None.

**Qualifiers**

None.

# **SYSMAN HELP**

---

## **HELP**

Provides online help for using the SYSMAN commands, parameters, and qualifiers. Press Ctrl/Z to exit.

## **Format**

HELP [keyword...]

## **Parameter**

### **keyword**

Specifies the command, parameter, or qualifier for which you want help. If you omit the keyword, the HELP command displays a list of Help topics and prompts you for a particular keyword.

## **Qualifiers**

None.

## **Example**

```
SYSMAN> HELP DO
```

This command displays help information about the SYSMAN command DO.

## IO AUTOCONFIGURE (Alpha and Integrity servers)

On Alpha and Integrity servers, automatically identifies and configures all hardware devices attached to a system by connecting devices and loading their drivers.

You must have CMKRNL and SYSLCK privileges to use the SYSMAN IO AUTOCONFIGURE command.

### Format

IO AUTOCONFIGURE

### Parameters

None.

### Qualifiers

#### **/SELECT=(device\_name)**

Specifies the device type to be automatically configured. Use valid device names or mnemonics that indicate the devices to be included in the configuration. You can use wildcard characters with this qualifier.

See the Usage Notes under the /EXCLUDE qualifier for notes that apply to both qualifiers.

Table 9–2 shows /SELECT qualifier examples.

**Table 9–2 /SELECT Qualifier Examples**

| Command      | Devices That Are Configured | Devices That Are Not Configured |
|--------------|-----------------------------|---------------------------------|
| /SELECT=P*   | PKA,PKB,PIA                 | None                            |
| /SELECT=PK*  | PKA,PKB                     | PIA                             |
| /SELECT=PKA* | PKA                         | PKB,PIA                         |

#### **/EXCLUDE=(device\_name)**

Specifies the device type that should not be automatically configured. Use valid device names or mnemonics that indicate the devices to be excluded from the configuration. You can use wildcard characters with this qualifier.

#### **Usage Notes for the /SELECT and /EXCLUDE Qualifiers**

- The /SELECT and /EXCLUDE qualifiers are not mutually exclusive and you can specify both qualifiers on the command line.
- You can use the /SELECT and /EXCLUDE qualifiers to permanently specify device autoconfiguration to include and exclude Fibre Channel port driver devices (FG) and any SCSI port driver devices (PK) for the duration of a manual autoconfiguration command. (To permanently specify devices to be excluded at each system boot, use the SYSMAN command IO SET EXCLUDE.)

## **SYSMAN IO AUTOCONFIGURE (Alpha and Integrity servers)**

You cannot use the `/SELECT` and `/EXCLUDE` qualifiers to include and exclude any of the following device types:

- SCSI class-driver devices (DK, MK, GK) whose names include a port allocation class or an HSZ allocation class
- Fibre Channel class-driver devices (PG, DG, GG)

This restriction also applies to SCSI devices on OpenVMS Alpha Version 7.1 systems, if the SCSI device names include a port allocation class.

### **/LOG**

Controls whether the SYSMAN IO AUTOCONFIGURE command displays information about loaded devices.

## **Description**

The SYSMAN IO AUTOCONFIGURE command identifies and configures all hardware devices attached to a system. It connects devices and loads their drivers. You must have CMKRNL and SYSLCK privileges to use the SYSMAN IO AUTOCONFIGURE command.

## **Examples**

1. SYSMAN> IO AUTOCONFIGURE/EXCLUDE=DKA0

This command autoconfigures all devices on the system except DKA0.

IO AUTOCONFIGURE automatically configures all standard devices that are physically attached to the system, except for the network communications device.

2. SYSMAN> IO AUTOCONFIGURE/LOG

The `/LOG` qualifier displays information about all the devices that AUTOCONFIGURE loads.



## **IO CONNECT (Alpha and Integrity servers)**

On Alpha and Integrity servers, connects a hardware device and loads its driver, if the driver is not already loaded.

You must have CMKRNL and SYSLCK privileges to use the SYSMAN IO CONNECT command.

---

**Note**

---

Be very careful when issuing a SYSMAN IO CONNECT command because the system does little error-checking. A misspelled device name, for example, will damage the I/O database and could cause the system to fail.

---

### **Format**

IO CONNECT device-name[:]

### **Parameter**

**device-name[:]**

Specifies the name of the hardware device to be connected. The device name requires the following format:

device-type controller unit-number

For example, in the designation LPA0, LP is a line printer on controller A at unit number 0. If you use the /NOADAPTER qualifier, the device is the software to be loaded.

### **Qualifiers**

**/ADAPTER=tr\_number**

**/NOADAPTER (default)**

Specifies the nexus number of the adapter to which the specified device is connected. It is a nonnegative 32-bit integer. The /NOADAPTER qualifier indicates that the device is not associated with any particular hardware. The /NOADAPTER qualifier is compatible with the /DRIVER\_NAME qualifier only.

**/CSR=csr\_address**

Specifies the CSR address for the device being configured. This address must be specified in hexadecimal. You must precede the CSR address with %X. The CSR address is a quadword value that is loaded into IDB\$Q\_CSR without any interpretation by SYSMAN. This address can be physical or virtual, depending on the specific device being connected:

- /CSR=%X3A0140120 for a physical address
- /CSR=%XFFFFFFFF807F8000 for a virtual address (the sign extension is required for Alpha and Integrity servers virtual addresses)

This qualifier is required if /ADAPTER=tr\_number is specified.

## **SYSMAN IO CONNECT (Alpha and Integrity servers)**

### **/DRIVER\_NAME=filespec**

Specifies the name of the device driver that you are loading. If you do not specify this qualifier, SYSMAN obtains the default in the same way that the SYSGEN default name is determined. For example, if you want to load the HP-supplied SYS\$ELDRIVER.EXE, the prefix SYS\$ must be present. Without the SYS\$, SYSMAN looks for ELDRIVER.EXE in SYS\$LOADABLE\_IMAGES. This implementation separates the user device driver namespace from the HP-supplied device driver namespace.

### **/LOG=(ALL,CRB,DDB,DPT,IDB,SB,UCB)**

#### **/NOLOG (default)**

Controls whether SYSMAN displays the addresses of the specified control blocks. The default value for the /LOG qualifier is /LOG=ALL. If /LOG=UCB is specified, a message similar to the following one is displayed:

```
%SYSMAN-I-IOADDRESS, the UCB is located at address 805AB000
```

### **/MAX\_UNITS=maximum-number-of-units**

Specifies the maximum number of units the driver can support. The default is specified in the driver prologue table (DPT) of the driver. If the number is not specified in the DPT, the default is 8. This number must be greater than or equal to the number of units specified by /NUM\_UNITS. This qualifier is optional.

### **/NUM\_UNITS=number-of-units**

Specifies the number of units to be created. The starting device number is the number specified in the device name parameter. For example, the first device in DKA0 is 0. Subsequent devices are numbered sequentially. The default is 1. This qualifier is optional.

### **/NUM\_VEC=vector-count**

Specifies the number of vectors for this device. The default vector count is 1. The /NUM\_VEC qualifier is optional. This qualifier should be used only when using the /VECTOR\_SPACING qualifier. When using the /NUM\_VEC qualifier, you must also use the /VECTOR qualifier to supply the base vector.

### **/SYS\_ID=number-of-remote-system**

Indicates the SCS system ID of the remote system to which the device is to be connected. It is a 64-bit integer; you must specify the remote system number in hexadecimal. The default is the local system. This qualifier is optional.

### **/VECTOR=(vector-address,...)**

Specifies the interrupt vectors for the device or lowest vector. This is either a byte offset into the SCB of the interrupt vector for directly vectored interrupts or a byte offset into the ADP vector table for indirectly vectored interrupts. The values must be longword aligned. To specify the vector address in octal or hexadecimal, precede the address with %O or %X, respectively. The /VECTOR qualifier is required when you use the /ADAPTER=*tr\_number* qualifier or the /NUM\_VEC=*vector-count* qualifier. You can list up to 64 vectors.

### **/VECTOR\_SPACING=number-of-bytes-between-vectors**

Specifies the spacing between vectors. Specify the amount as a multiple of 16 bytes. The default is 16. You must specify both the base vector with /VECTOR and the number of vectors with /NUM\_VEC. This qualifier is optional.

## Description

The SYSMAN IO CONNECT command connects a hardware device and loads its driver, if the driver is not already loaded. You must have CMKRNL and SYSLCK privileges to use the SYSMAN IO CONNECT command.

The chapter “Managing Peripheral Devices” in the *HP OpenVMS System Manager’s Manual* contains information about file-based device configuration support.

## Examples

1. SYSMAN> IO CONNECT DKA0:/DRIVER NAME=SYS\$DKDRIVER/CSR=%X80AD00-  
/ADAPTER=4/NUM\_VEC=3/VECTOR\_SPACING=%X10/VECTOR=%XA20/LOG  
  
%SYSMAN-I-IOADDRESS, the CRB is located at address 805AEC40  
%SYSMAN-I-IOADDRESS, the DDB is located at address 805AA740  
%SYSMAN-I-IOADDRESS, the DPT is located at address 80D2A000  
%SYSMAN-I-IOADDRESS, the IDB is located at address 805AEE80  
%SYSMAN-I-IOADDRESS, the SB is located at address 80417F80  
%SYSMAN-I-IOADDRESS, the UCB is located at address 805B68C0

The command in this example connects device DKA0, loads driver SYS\$DKDRIVER, and specifies the following data:

- Physical CSR address
- Adapter number
- Number of vectors
- Spacing between vectors
- Interrupt vector address

The /LOG qualifier displays the addresses of all control blocks, as shown.

2. SYSMAN> IO CONNECT DKA0:/DRIVER NAME=SYS\$DKDRIVER/CSR=%X80AD00-  
/ADAPTER=4/VECTOR=(%XA20,%XA30,%XA40)/LOG=(CRB,DPT,UCB)  
  
%SYSMAN-I-IOADDRESS, the CRB is located at address 805AEC40  
%SYSMAN-I-IOADDRESS, the DPT is located at address 80D2A000  
%SYSMAN-I-IOADDRESS, the UCB is located at address 805B68C0

The command in this example connects device DKA0, loads driver SYS\$DKDRIVER, and specifies the following data:

- Physical CSR address
- Adapter number
- Addresses for interrupt vectors

The /LOG qualifier displays the addresses of the channel request block (CRB), the driver prologue table (DPT), and the unit control block (UCB).

3. SYSMAN> IO CONNECT FTA0:/DRIVER=SYS\$FTDRIVER/NOADAPTER/LOG=(ALL)  
  
%SYSMAN-I-IOADDRESS, the CRB is located at address 805AEC40  
%SYSMAN-I-IOADDRESS, the DDB is located at address 805AA740  
%SYSMAN-I-IOADDRESS, the DPT is located at address 80D2A000  
%SYSMAN-I-IOADDRESS, the IDB is located at address 805AEE80  
%SYSMAN-I-IOADDRESS, the SB is located at address 80417F80  
%SYSMAN-I-IOADDRESS, the UCB is located at address 805B68C0

The command in this example connects pseudoterminal FTA0, loads driver SYS\$FTDRIVER, and uses the /NOADAPTER qualifier to indicate that FTA0 is not an actual hardware device. The /LOG=(ALL) qualifier displays the addresses of all control blocks, as shown.

## **SYSMAN IO CONNECT (Alpha and Integrity servers)**

For more information about loading and configuring device drivers, see *Writing OpenVMS Alpha Device Drivers in C* (Margie Sherlock and Leonard S. Szubowicz, Digital Press, 1996).

## **IO CREATE\_WWID (Alpha and Integrity servers)**

Assigns a specific, previously unused device name to a specific, previously unused worldwide identifier (WWID) from the SYSMAN IO LIST\_WWID display.

HP recommends that you execute this command clusterwide and that you follow the command with a SYSMAN IO AUTOCONFIGURE command to actually configure the device.

### **Format**

```
IO CREATE_WWID devnam_string/WWID=wwid_string
```

### **Parameter**

#### **devnam\_string**

Specifies a device-name string. The string must be in the form \$2\$MGA $n$ , where  $n$  is less than 9999.

### **Qualifier**

#### **/WWID=wwid\_string**

Specifies a WWID string that comes directly from a SYSMAN IO LIST\_WWID display.

This qualifier is required.

### **Description**

This command is an alternative to the SYSMAN IO FIND\_WWID command, which selects system-generated device names for the discovered WWIDs. Do not, however, use the SYSMAN IO CREATE\_WWID command after the SYSMAN IO FIND\_WWID command to redefine WWID correlations. Also, do not specify device and WWID strings in the SYSMAN IO CREATE\_WWID command that are specified elsewhere in the cluster.

### **Example**

```
SYSMAN> SET ENVIRONMENT/CLUSTER
SYSMAN> IO CREATE_WWID $2$MGA5/WWID=04100022:"DEC TZ89 (C) DECCX939S2777"
SYSMAN> IO CREATE_WWID $2$MGA3/WWID=02000008:500E-09E0-0005-30D7
SYSMAN> IO AUTOCONFIGURE
```

The commands in this example create two device names, \$2\$MGA5 and \$2\$MGA3, and configure the devices.

## **SYSMAN IO FIND\_WWID (Alpha and Integrity servers)**

---

### **IO FIND\_WWID (Alpha and Integrity servers)**

The SYSMAN IO FIND\_WWID command probes all Fibre Channel ports, detects all previously undiscovered tapes and medium changers behind a Network Storage Router (NSR) or a Modular Data Router (MDR), and assigns a worldwide identifier (WWID) to each one.

The command also displays a list of the devices and their assigned device names and automatically records this information in the SYS\$SYSTEM:SYS\$DEVICES.DAT file. Finally, the command updates relevant local and clusterwide memory structures.

To configure newly attached Fibre Channel tapes, use this command prior to running the SYSMAN command IO AUTOCONFIGURE.

You must have CMKRNL privilege to use the SYSMAN IO FIND\_WWID command.

For more information about Fibre Channel, see the *Guidelines for OpenVMS Cluster Configurations*.

### **Format**

IO FIND\_WWID

### **Description**

Prior to configuring a tape device on Fibre Channel ports, the worldwide identifier (WWID) of the device must be detected and stored, along with a device name, in the text file SYS\$SYSTEM:SYS\$DEVICES.DAT. You use the SYSMAN command IO FIND\_WWID to accomplish this.

The SYSMAN IO FIND\_WWID command probes all Fibre Channel ports and locates all tape and medium changer devices. For tapes and medium changers that have not been detected by any previous SYSMAN IO FIND\_WWID command, IO FIND\_WWID assigns a device name, retrieves the WWID of the device, stores the device name and WWID data in the SYS\$SYSTEM:SYS\$DEVICES.DAT file, and updates memory structures.

Because the main goal of SYSMAN IO FIND\_WWID is to populate the SYS\$DEVICES.DAT file, you need to invoke the SYSMAN IO FIND\_WWID command only one time for each new device. Note that using the SYSMAN IO FIND\_WWID command for the first time detects all existing tape and medium changer devices on the system at that time.

Once the information is stored in the file, subsequent use of the SYSMAN IO AUTOCONFIGURE command reads the file and configures the tape and medium changer devices automatically, loading or connecting the device drivers as needed. The SYS\$DEVICES.DAT file is read during each system reboot, initiating the automatic configuration of tapes and medium changers on the Fibre Channel. (SYSMAN IO FIND\_WWID does not load or connect the actual device drivers.)

---

#### **Note**

---

If you add more devices to the system at a later time, you must powercycle the MDR to update internal mapping information. You must also run the SYSMAN IO FIND\_WWID command again to append the new device information to the SYS\$DEVICES.DAT file.

## SYSMAN IO FIND\_WWID (Alpha and Integrity servers)

Similarly, for the Network Storage Router (NSR), the LUN map must be updated.

---

In an OpenVMS cluster environment, you must run the SYSMAN IO FIND\_WWID command on each node in the cluster to update various data structures in memory. Alternatively, you can run SYSMAN IO FIND\_WWID on one node, and then reboot the other nodes that share that same system disk, because the SYS\$DEVICES.DAT file is read at boot time and causes memory structures to be correctly initialized.

In the case of multiple system disks in the cluster, ensure that all copies of the SYS\$DEVICES.DAT file are kept consistent, preferably by running the SYSMAN IO FIND\_WWID command on all nodes. Alternatively, you can run IO FIND\_WWID to update just one SYS\$DEVICES.DAT file, and then manually edit the remaining SYS\$DEVICES.DAT files by cutting and pasting the appropriate devnam/WWID records from the original file to the target files.

HP recommends that you refrain from copying the entire original file to another system disk, because the SYS\$DEVICES.DAT file is also used to define Port Allocation Classes, and PAC entries could be inadvertently transferred to the target system.

### Example

```
SYSMAN> IO FIND_WWID
%SYSMAN-I-OUTPUT, command execution on node SAMPLE
On port _SAMPLE$PGA0:, the following tape WWIDs and their proposed
device names have been found but not yet configured:

    [Device $2$GGA0]
    WWID=04100024:"DEC      TL800      (C) DEC3G9CCR82A017"

    [Device $2$MGA0]
    WWID=04100022:"DEC      TZ89       (C) DECCX939S2777"

    [Device $2$MGA1]
    WWID=04100022:"DEC      TZ89       (C) DECCX942S6295"
```

This is a configuration example using a TL891 tape library. The SYSMAN command IO FIND\_WWID displays a list of all previously undiscovered tape devices and their device names.

Note that the overall WWID consists of everything to the right of the equal sign. Each such WWID is unique; however, the header portion might not be unique, because the header reflects only the basic type and length of the WWID data.

The SYSMAN IO FIND\_WWID command automatically records the information about the new tape devices in SYS\$SYSTEM:SYS\$DEVICES.DAT:

## **SYSMAN IO FIND\_WWID (Alpha and Integrity servers)**

```
$ TYPE SYS$SYSTEM:SYS$DEVICES.DAT
!
! Updated 23-OCT-2002 14:17:41.85: DEC TL800
!
[Device $2$GGA0]
WWID=04100024:"DEC      TL800      (C) DEC3G9CCR82A017"
!
!
! Updated 23-OCT-2002 14:17:41.93: DEC TZ89
!
[Device $2$MGA0]
WWID=04100022:"DEC      TZ89      (C) DECCX939S2777"
!
!
! Updated 23-OCT-2002 14:17:42.01: DEC TZ89
!
[Device $2$MGA1]
WWID=04100022:"DEC      TZ89      (C) DECCX942S6295"
!
```

You would then use the SYSMAN command IO CONFIGURE to configure these devices. After you completed this step, the SHOW DEVICE/FULL command would display the worldwide identifier of the tape.



## **IO LIST\_WWID (Alpha and Integrity servers)**

Applies only to tape devices on Fibre Channel. Lists all tape device WWIDs that are not yet configured on Fibre Channel.

You can use the output of this command as input to the SYSMAN IO CREATE\_WWID and SYSMAN IO REPLACE\_WWID commands.

### **Format**

IO LIST\_WWID

### **Example**

```
SYSMAN> IO LIST_WWID
%SYSMAN-I-OUTPUT, command execution on node ROCKY

On port _ROCKY$PGA0:, the following tape WWIDs are not yet configured:

Target 3, LUN 1, COMPAQ SuperDLT1
WWID=02000008:500E-09E0-0005-30D7

Target 3, LUN 3, COMPAQ SDX-500C
WWID=0C000008:0800-4606-C00D-473F

Target 4, LUN 1, COMPAQ SuperDLT1
WWID=02000008:500E-09E0-0005-30D7

Target 4, LUN 3, COMPAQ SDX-500C
WWID=0C000008:0800-4606-C00D-473F
```

In this example, each drive is listed twice because the tape bridge is dual-ported, with one FC port at target 3 and the other FC port at target 4.

## **SYSMAN IO LOAD (Alpha and Integrity servers)**

---

### **IO LOAD (Alpha and Integrity servers)**

On Alpha and Integrity servers, loads an I/O driver.

You must have CMKRNL and SYSLCK privileges to use the SYSMAN IO LOAD command.

---

#### **Note**

---

Be very careful when issuing a SYSMAN IO LOAD command because the system does little error-checking.

---

### **Format**

IO LOAD filespec

### **Parameter**

#### **filespec**

Specifies the file name of the driver to be loaded. This parameter is required.

### **Qualifier**

#### **/LOG=(ALL,DPT)**

Controls whether SYSMAN displays information about drivers that have been loaded. The default value for the /LOG qualifier is /LOG=ALL. The driver prologue table (DPT) address is displayed when either /LOG=DPT or /LOG=ALL is specified.

### **Description**

The SYSMAN IO LOAD command loads an I/O driver. You must have CMKRNL and SYSLCK privileges to use the SYSMAN IO LOAD command.

### **Example**

```
SYSMAN> IO LOAD/LOG SYS$DKDRIVER
%SYSMAN-I-IOADDRESS, the DPT is located at address 80D5A000
```

This example loads device SYS\$DKDRIVER and displays the address of the driver prologue table (DPT).

## **IO REBUILD (Alpha and Integrity servers)**

On Alpha and Integrity servers, rebuilds device configuration tables in preparation for using the SYSMAN IO AUTOCONFIGURE command to reconfigure the system.

You must have CMKRNL privilege to use the SYSMAN IO REBUILD command.

### **Format**

IO REBUILD

### **Parameters**

None.

### **Qualifier**

#### **/VERIFY**

Causes SYSMAN to read and process the files SYS\$SYSTEM:SYS\$USER\_CONFIG.DAT and SYS\$SYSTEM:CONFIG.DAT, but not to apply the files to the I/O database. Messages will be displayed for any errors that are encountered. This command can be used by developers to test new changes to SYS\$SYSTEM:SYS\$USER\_CONFIG.DAT without modifying the current system.

### **Description**

The SYSMAN IO REBUILD command rebuilds the system's device configuration tables by reading and parsing the SYS\$SYSTEM:SYS\$USER\_CONFIG.DAT and SYS\$SYSTEM:SYS\$CONFIG.DAT files.

To debug modifications to the SYS\$SYSTEM:SYS\$USER\_CONFIG.DAT file, you can use the SYSMAN IO REBUILD and SYSMAN IO AUTOCONFIGURE commands to load drivers without having to reboot. Once you load a driver for an adapter, however, you cannot reload it without rebooting the system.

### **Example**

```
SYSMAN> IO REBUILD  
SYSMAN> IO AUTOCONFIGURE
```

The first command in this example rebuilds device configuration tables. The second command reads the device configuration tables and loads drivers for newly defined drivers.

## SYSMAN IO REPLACE\_WWID (Alpha and Integrity servers)

---

### IO REPLACE\_WWID (Alpha and Integrity servers)

This command allows a user to replace one tape drive behind a Network Storage Router (NSR) with another tape drive at the same Fibre Channel (FC) Logical Unit Number (LUN) location.

This command updates all the necessary file and memory data structures with the WWID of the new tape drive. The name of the replacement drive will be the same as the name of the original drive.

This command is primarily intended to be used when a hardware problem occurs on a tape drive, and a replacement drive must be installed in its place.

The command requires CMKRNL privilege. It applies only to FC tapes behind a Fibre Channel tape bridge such as an NSR or MDR (Modular Data Router).

For more information about Fibre Channel, see the *Guidelines for OpenVMS Cluster Configurations*.

#### Format

```
IO REPLACE_WWID devnam_string/WWID=wwid_string
```

#### Parameter

**devnam\_string**

Specifies a tape device name.

#### Qualifier

**/WWID=wwid\_string**

Specifies a string that comes directly from a SYSMAN IO LIST\_WWID display. The use of this qualifier is appropriate only under the circumstances explained in the description below.

#### Description

You can use the two parameters, *devnam\_string* and *wwid\_string*, with the REPLACE\_WWID command to replace a broken tape device with a new device. The command automatically updates the data structures that record the new devnam-WWID correlation, and the device automatically begins to function correctly.

This command is useful in two different cases:

- In one case, the drive might malfunction and need to be replaced immediately without rebooting the system. If this happens, the drive is physically replaced with a new drive, and the command SYSMAN IO REPLACE\_WWID \$2\$MGAn is issued clusterwide. The /WWID qualifier is not appropriate in this case, because the new WWID is automatically detected using information stored in the device's data structures.
- In the other case, the drive might malfunction and not be replaced until after the system has been shut down or rebooted. The device name no longer appears in the SHOW DEVICE display because the device failed to configure during the reboot.

## SYSMAN

### IO REPLACE\_WWID (Alpha and Integrity servers)

The configuration failure occurred either because the broken drive did not respond, or because the new drive has a different WWID from the one SYSMAN IO AUTOCONFIGURE expected at boot time. Therefore, in this situation, in which the device name is in SYS\$DEVICES.DAT but not in the SHOW DEVICE display, use the /WWID qualifier to define the new devnam-WWID correlation.

Follow these steps clusterwide:

1. Execute the SYSMAN IO LIST\_WWID command to display the new WWID.
2. Use the command SYSMAN IO REPLACE\_WWID \$2\$MGA<sub>n</sub>/WWID=new\_wwid to define the new correlation.
3. Use the SYSMAN IO AUTOCONFIGURE command to configure the device.

When you use the SYSMAN IO LIST\_WWID command, keep in mind that:

- You must set the replacement device to the same SCSI target ID as the original device.
- You must stop all activity on the device before issuing the SYSMAN IO REPLACE\_WWID command.
- The command requires CMKRNL privilege and applies only to FC tapes behind an NSR or MDR.

### Example

```
SYSMAN> SET ENVIRONMENT/CLUSTER
SYSMAN> IO REPLACE_WWID $2$MGA3/WWID=02000008:500E-09E0-0005-30D7
SYSMAN> IO AUTOCONFIGURE
```

In this example, the device named \$2\$MGA3 malfunctioned and was replaced while the system was down. Upon reboot, the drive did not get configured, because its new WWID did not match the WWID that OpenVMS expected. Therefore, the user redefines the devnam-WWID correlation and is then able to configure \$2\$MGA3 correctly. The specified WWID comes from the output of the SYSMAN IO LIST\_WWID command.

## **SYSMAN IO SCSI\_PATH\_VERIFY (Alpha and Integrity servers)**

---

### **IO SCSI\_PATH\_VERIFY (Alpha and Integrity servers)**

On Alpha and Integrity servers, the SYSMAN IO SCSI\_PATH\_VERIFY subcommand checks each SCSI and FC path in the system to determine whether the attached device has been changed. If a device change is detected, then the SCSI or FC path is disconnected in the IO database. This allows the path to be reconfigured on the new device, by using the SYSMAN IO AUTOCONFIGURE command.

You must have CMKRNL privilege to use the SYSMAN IO SCSI\_PATH\_VERIFY command.

#### **Format**

IO SCSI\_PATH\_VERIFY

#### **Parameters**

None.

#### **Qualifiers**

None.

#### **Description**

You usually enter the SYSMAN IO SCSI\_PATH\_VERIFY command after performing an online reconfiguration of a SCSI or an FC interconnect. The command reads the device type and device identifier on each SCSI and FC path in the system. If the device does not match the data stored in the IO database, then the path is disconnected in the IO database. Following a SYSMAN IO SCSI\_PATH\_VERIFY command, you usually enter a SYSMAN IO AUTOCONFIGURE command, which updates the IO database to match the new SCSI or FC configuration.

#### **Example**

```
SYSMAN> IO SCSI_PATH_VERIFY  
SYSMAN> IO AUTOCONFIGURE
```

The first command in this example checks all SCSI paths and disconnects the ones that are no longer valid. The second command autoconfigures all devices that are physically attached to the system.

## IO SET EXCLUDE (Alpha and Integrity servers)

On Alpha and Integrity servers, sets the permanent exclusion list to be used when configuring devices automatically.

### Format

IO SET EXCLUDE = device\_name

### Parameter

#### **device\_name**

Specifies the device type to be excluded from automatic configuration. Use valid device names or mnemonics that indicate the devices to be included in the permanent exclusion list. You can specify wildcards.

### Qualifiers

None.

### Description

Sets the permanent exclusion list to be used when configuring devices.

You can use this command to permanently specify device autoconfiguration to exclude Fibre Channel port driver devices (FG) and any SCSI port driver devices (PK) at each system boot. (To specify permanently the exclusion or inclusion of devices for the duration of a manual configuration command, use the /EXCLUDE or /SELECT qualifier with the SYSMAN IO AUTOCONFIGURE command.)

You cannot use the SYSMAN IO SET EXCLUDE command to exclude any of the following device types:

- SCSI class-driver devices (DK, MK, GK) whose names include a port allocation class or an HSZ allocation class
- Fibre Channel class-driver devices (PG, DG, GG)

This restriction also applies to SCSI devices on OpenVMS Alpha Version 7.1 systems, if the SCSI device names include a port allocation class.

### Example

```
SYSMAN> IO SET EXCLUDE=(DKC500,DKD*)
```

This example specifies that DKC500 and all DKD devices are not to be autoconfigured.

For additional examples that show how to specify device names, see the /SELECT qualifier.

## **SYSMAN IO SET PREFIX (Alpha and Integrity servers)**

---

### **IO SET PREFIX (Alpha and Integrity servers)**

On Alpha and Integrity servers, sets the prefix list that is used to manufacture the IOGEN Configuration Building Module (ICBM) names.

#### **Format**

```
IO SET PREFIX =icbm_prefix
```

#### **Parameter**

##### **icbm\_prefix**

Specifies ICBM prefixes. These prefixes are used by the SYSMAN IO AUTOCONFIGURE command to build ICBM image names.

#### **Qualifiers**

None.

#### **Description**

The SYSMAN IO SET PREFIX command sets the prefix list which is used to manufacture ICBM names.

#### **Example**

```
SYSMAN> IO SET PREFIX=(SYS$,PSI$,VME_)
```

This example specifies the prefix names used by SYSMAN IO AUTOCONFIGURE to build the ICBM names. The prefixes are SYS\$, PSI\$, and VME\_.



---

## IO SHOW BUS (Alpha and Integrity servers)

On Alpha and Integrity servers, lists all the buses, node numbers, bus names, TR numbers, and base CSR addresses on the system. This display exists primarily for internal engineering support.

### Parameters

None.

### Qualifiers

None.

### Description

The SYSMAN IO SHOW BUS command lists all the buses, node numbers, bus names, TR numbers, and base CSR addresses. This display exists primarily for internal engineering support. You must have CMKRNL privilege to use SYSMAN IO SHOW BUS.

### Example

```
SYSMAN> IO SHOW BUS
```

| Bus          | Node | TR# | Name        | Base CSR         |
|--------------|------|-----|-------------|------------------|
| LSB          | 0    | 1   | EV3 4MB     | FFFFFFFF86FA0000 |
| LSB          | 6    | 1   | MEM         | FFFFFFFF86FC4000 |
| LSB          | 7    | 1   | MEM         | FFFFFFFF86FCA000 |
| LSB          | 8    | 1   | IOP         | FFFFFFFF86FD0000 |
| XZA XMI-SCSI | 0    | 3   | XZA-SCSI    | 0000008001880000 |
| XZA XMI-SCSI | 1    | 3   | XZA-SCSI    | 0000008001880000 |
| XZA XMI-SCSI | 0    | 4   | XZA-SCSI    | 0000008001900000 |
| XZA XMI-SCSI | 1    | 4   | XZA-SCSI    | 0000008001900000 |
| XMI          | 4    | 2   | LAMB        | 0000008001A00000 |
| DEMNA        | 0    | 5   | Generic XMI | 0000008001E80000 |
| DEMNA        | 0    | 6   | Generic XMI | 0000008001F00000 |

This example is from a DEC 7000 Model 600. Displays vary among different Alpha and Integrity servers.

The indentation levels are deliberate in this display. They indicate the hierarchy of the adapter control blocks in the system. The column titles in the display have the following meanings:

## SYSMAN IO SHOW BUS (Alpha and Integrity servers)

| Column Titles | Meaning  |
|---------------|--|
| Bus           | Identity of the bus  |
| Node          | Index into the associated bus array; the bus slot                      |
| TR#           | Nexus number of the adapter to which the specified device is connected |
| Name          | Name of the device   |
| Base CSR      | Base CSR address of the device   |

On Alpha and Integrity servers, you can use the SDA command `CLUE CONFIG` to display additional information including hardware adapters and devices. This command is documented in the *OpenVMS Alpha System Dump Analyzer Utility Manual*.

For more information about loading and configuring device drivers, see *Writing OpenVMS Alpha Device Drivers in C*.

## **IO SHOW DEVICE (Alpha and Integrity servers)**

On Alpha and Integrity servers, displays information about device drivers loaded into the system, the devices connected to them, and their I/O databases. All addresses are in hexadecimal and are virtual.

### **Format**

IO SHOW DEVICE

### **Parameters**

None.

### **Qualifiers**

None.

### **Description**

The SYSMAN IO SHOW DEVICE command displays information about the device drivers loaded into the system, the devices connected to them, and their I/O databases.

The SYSMAN IO SHOW DEVICE command specifies that the following information be displayed about the specified device driver:

|        |  |
|--------|--|
| Driver | Name of the driver                               |
| Dev    | Name of each device connected to the driver      |
| DDB    | Address of the device's device data block        |
| CRB    | Address of the device's channel request block    |
| IDB    | Address of the device's interrupt dispatch block |
| Unit   | Number of each unit on the device                |
| UCB    | Address of each unit's unit control block        |

All addresses are in hexadecimal and are virtual.

For additional information about SYSMAN, see *A Comparison of System Management on OpenVMS AXP and OpenVMS VAX* (archived) but available on the OpenVMS Documentation CD-ROM) and the *HP OpenVMS System Manager's Manual*.

### **Example**

```
SYSMAN> IO SHOW DEVICE
```

The following example is a sample display produced by the SYSMAN IO SHOW DEVICE command:

## **SYSMAN IO SHOW DEVICE (Alpha and Integrity servers)**

| <u>Driver</u> | <u>Dev_DDB</u> | <u>CRB</u> | <u>IDB</u> | <u>Unit_UCB</u> |
|---------------|----------------|------------|------------|-----------------|
| SY\$FTDRIVER  | FTA 802CE930   | 802D1250   | 802D04C0   |                 |
|               |                |            |            | 0 801C3710      |
| SY\$EUDRIVER  | EUA 802D0D80   | 802D1330   | 802D0D10   |                 |
|               |                |            |            | 0 801E35A0      |
| SY\$DKDRIVER  | DKI 802D0FB0   | 802D0F40   | 802D0E60   |                 |
|               |                |            |            | 0 801E2520      |
| SY\$PKADRIVER | PKI 802D1100   | 802D13A0   | 802D1090   |                 |
|               |                |            |            | 0 801E1210      |
| SY\$TTDRIVER  |                |            |            |                 |
| OPERATOR      |                |            |            |                 |
| NLDRIVER      |                |            |            |                 |

SY\$TTDRIVER, OPERATOR, and NLDRIVER do not have devices associated with them.

## **IO SHOW EXCLUDE (Alpha and Integrity servers)**

On Alpha and Integrity servers, displays the permanent exclusion list used in the autoconfiguration of devices.

### **Format**

IO SHOW EXCLUDE

### **Parameters**

None.

### **Qualifiers**

None.

### **Description**

The SYSMAN IO SHOW EXCLUDE command displays the permanent exclusion list on the console. This list is used in the autoconfiguration of devices.

### **Example**

```
SYSMAN> IO SHOW EXCLUDE
%SYSMAN-I-IOEXCLUDE, the current permanent exclusion list is: DKC500,DKD*
```

This example shows the permanent exclusion list used in the autoconfiguration of devices; the current list contains DKC500 and all DKD devices.

## **SYSMAN IO SHOW PREFIX (Alpha and Integrity servers)**

---

### **IO SHOW PREFIX (Alpha and Integrity servers)**

On Alpha and Integrity servers, displays the current prefix list used in the manufacture of IOGEN Configuration Building Module (ICBM) names.

#### **Format**

IO SHOW PREFIX

#### **Parameters**

None.

#### **Qualifiers**

None.

#### **Description**

The SYSMAN IO SHOW PREFIX command displays the current prefix list on the console. This list is used by the SYSMAN IO AUTOCONFIGURE command to build ICBM names.

#### **Example**

```
SYSMAN> IO SHOW PREFIX  
%SYSMAN-I-IOPREFIX, the current prefix list is: SYS$,PSI$,VME_
```

This example shows the prefixes used by SYSMAN IO AUTOCONFIGURE to build ICBM names.

---

## LICENSE LOAD

Activates licenses registered in the LICENSE database.

Requires CMKRNL, SYSNAM, and SYSPRV privileges.

---

### Note

---

Except for the number of status messages returned, the following commands are functionally equivalent:

```
SYSMAN> LICENSE LOAD
$ LICENSE LOAD
```

To see all the status messages on remote nodes for the DCL command, you can use the following SYSMAN command:

```
SYSMAN> DO LICENSE LOAD
```

---

### Format

```
LICENSE LOAD product
```

### Parameter

**product**

Specifies the name of the product whose license you want to activate.

### Qualifiers

**/DATABASE=filespec**

Specifies the location of the LICENSE database. The default file specification is SYS\$COMMON:[SYSEXE]LMF\$LICENSE.LDB. Using the /DATABASE qualifier is not necessary if you use the default LICENSE database name and location.

**/PRODUCER=string**

Specifies the name of the company that owns the product for which you have a license. Use this qualifier only if the product is from a company other than HP.

### Description

You can use the LICENSE LOAD command to activate licenses on multiple systems and on nonlocal systems in the system management environment. The SYSMAN LICENSE commands are a subset of the License Management Facility (LMF) commands. For more information about the LMF, see the *HP OpenVMS License Management Utility Manual*.

### Example

```
SYSMAN> LICENSE LOAD FORTRAN
```

This example activates the license for HP Fortran for OpenVMS. Because the license is for a HP product, the command does not include the /PRODUCER qualifier.

# SYSMAN LICENSE UNLOAD

---

## LICENSE UNLOAD

Deactivates licenses registered in the LICENSE database.

Requires CMKRNL, SYSNAM, and SYSPRV privileges.

### Format

```
LICENSE UNLOAD [product]
```

### Parameter

#### **product**

Specifies the name of the product whose license you want to deactivate. If you enter the LICENSE UNLOAD command without specifying a product name, the system deactivates all available registered licenses.

### Qualifier

#### **/PRODUCER=string**

Specifies the name of the company that owns the product for which you have a license. Use this qualifier only if the product is from a company other than HP.

### Description

You can use the LICENSE UNLOAD command to deactivate licenses on multiple systems and on nonlocal systems in the system management environment. The SYSMAN LICENSE commands are a subset of the License Management Facility (LMF) commands. For more information about the LMF, see the *HP OpenVMS License Management Utility Manual*.

### Example

```
SYSMAN> LICENSE UNLOAD FORTRAN
```

This command deactivates the license for HP Fortran for OpenVMS. Because the license is for a HP product, the command does not include the /PRODUCER qualifier.



---

## PARAMETERS DISABLE CHECKS

Bypasses validation of parameter values. SYSMAN parameter validation ensures that the parameters fall within the defined minimum and maximum values specified in the PARAMETERS SET command.

### Format

PARAMETERS DISABLE CHECKS

### Parameters

None.

### Qualifiers

None.

### Description

The PARAMETERS DISABLE CHECKS command enables you to override minimum and maximum values established for system parameters. SYSMAN does parameter checks by default. If you attempt to set parameter values outside the allowable limits when checks are enabled, the operating system issues an error message. By disabling checks you can set parameter values regardless of the minimum and maximum limits.

---

**Note**

---

Range checks are enabled by default because HP suggests that systems operate within these minimum and maximum values. Setting parameters outside these limits can result in system failures or hangs.

---

### Example

```
SYSMAN> SET ENVIRONMENT/CLUSTER
SYSMAN> SET PROFILE/DEFAULT=SYS$SYSTEM/PRIVILEGES=CMEXEC
SYSMAN> PARAMETERS SET MAXPROCESSCNT 10
%SMI-E-OUTRANGE, parameter is out of range
SYSMAN> PARAMETERS DISABLE CHECKS
SYSMAN> PARAMETERS SET MAXPROCESSCNT 10
```

In this example, the initial attempt to set MAXPROCESSCNT below the minimum fails because range checks are enabled. However, once range checks are disabled, the PARAMETERS SET MAXPROCESSCNT command succeeds.

## **SYSMAN PARAMETERS ENABLE CHECKS**

---

### **PARAMETERS ENABLE CHECKS**

Validates all parameter values to ensure that they fall within the defined minimum and maximum values.

Because range checks are enabled by default, use **PARAMETERS ENABLE CHECKS** after entering a **PARAMETERS DISABLE CHECKS** command.

#### **Format**

**PARAMETERS ENABLE CHECKS**

#### **Parameters**

None.

#### **Qualifiers**

None.

#### **Example**

```
SYSMAN> PARAMETERS DISABLE CHECKS
SYSMAN> PARAMETERS SET WSMAX 20
SYSMAN> PARAMETERS ENABLE CHECKS
SYSMAN> PARAMETERS SET WSMAX 30
%SMI-E-OUTRANGE, parameter is out of range
SYSMAN> PARAMETERS SHOW WSMAX
Parameter Name    Current  Default  Minimum  Maximum Unit  Dynamic
WSMAX              2000    1024     60      6400 pages
```

The **PARAMETERS ENABLE CHECKS** command in this example shows that when range checking is disabled, the system accepts a working set value (WSMAX) of 20. However, once range checking is enabled with the **PARAMETERS ENABLE CHECKS** command, the system does not accept a WSMAX below the minimum, which is 60.

---

## **PARAMETERS SET**

Changes the value of a specific parameter in the work area.

The **PARAMETERS SET** command does not modify parameter files, the current system parameter file on disk, or the active system. For information about performing these modifications, see the **PARAMETERS WRITE** command.

### **Format**

```
PARAMETERS SET parameter-name [value]
                /STARTUP filespec
```

### **Parameters**

#### **parameter-name**

Specifies the name of the parameter to modify. Instead of a name, you can enter a period (.) to change the value of the most recently displayed or the most recently modified parameter. See the **PARAMETERS SHOW** command for an example of using the period in place of a parameter name.

For a list of system parameters and further information about them, use the command **HELP PARAMETERS**.

#### **value**

Specifies the new value for the parameter. Enclose values for ASCII parameters in quotation marks if they contain embedded spaces or other special characters.

Typically the value is an integer or the keyword **DEFAULT**. The keyword **DEFAULT** sets the parameter to its default value. The **PARAMETERS SHOW** command displays the defined minimum, maximum, and default values for the parameter, which are required unless range checking is disabled with the command **PARAMETERS DISABLE CHECKS**.

### **Qualifier**

#### **/STARTUP filespec**

Sets the name of the site-independent startup procedure to the given file specification. A file specification has a maximum length of 31 characters. The initial startup command procedure is **SYS\$SYSTEM:STARTUP.COM**.

### **Examples**

1. **SYSMAN> PARAMETERS SET PFCDEFAULT 20**

This command assigns a value of 20 to the **PFCDEFAULT** parameter.

2. **SYSMAN> PARAMETERS SET GBLSECTIONS DEFAULT**

This command assigns the default value (40) to the **GBLSECTIONS** parameter.

3. **SYSMAN> PARAMETERS SET/STARTUP SYS\$SYSTEM:XSTARTUP.COM**

This command assigns **SYS\$SYSTEM:XSTARTUP.COM** as the current site-independent startup command procedure.

# **SYSMAN PARAMETERS SHOW**

---

## **PARAMETERS SHOW**

Displays the value of a parameter or a group of parameters in the work area. In addition, the command shows the minimum, maximum, and default values of a parameter and its unit of measure.

### **Format**

PARAMETERS SHOW [parameter-name]

### **Parameter**

#### **parameter-name**

Specifies the name of a parameter or a period (.). A period is interpreted as a request for the parameter specified in the last PARAMETERS SET or PARAMETERS SHOW command. The parameter name can be abbreviated, but the abbreviation must be unique because SYSMAN selects the first parameter that matches.

Beginning in OpenVMS Version 8.2, if the parameter-name that you enter is obsolete, SYSMAN displays OBSOLETE in the Units column.

### **Qualifiers**

#### **/ACP**

Displays all Files-11 ACP parameters.

#### **/ALL**

Displays the values of all active parameters.

#### **/CLUSTER**

Displays all parameters specific to clusters.

#### **/DYNAMIC**

Displays all parameters that would be in effect immediately after you enter a PARAMETERS WRITE ACTIVE command.

#### **/GEN**

Displays all general parameters.

#### **/HEX**

Displays numeric parameters in hexadecimal rather than decimal radix. Specify the /HEX system parameter name or the parameter type. If you specify the /HEX qualifier with the /NAMES qualifier, /HEX is ignored.

#### **/JOB**

Displays all job controller parameters.

#### **/LGI**

Displays all LOGIN security control parameters.

#### **/MAJOR**

Displays the most important parameters.

#### **/MULTIPROCESSING**

Displays parameters specific to multiprocessing.

**/NAMES**

Displays only parameter names. You can combine other qualifiers with this one.

**/OBSOLETE**

Displays the names of all obsolete system parameters.

**/OUTPUT**

Directs output to the specified file rather than SYS\$OUTPUT. Without a file specification, the output goes to SYSMAN.LIS in the current directory.

**/PAUSE**

Controls the rate at which the system displays information about parameters.

**/PQL**

Displays the parameters for all default process quotas.

**/RMS**

Displays all parameters specific to OpenVMS Record Management Services (RMS).

**/SCS**

Displays all parameters specific to OpenVMS Cluster System Communications Services.

**/SPECIAL**

Displays all special control parameters.

**/STARTUP**

Displays the name of the site-independent startup procedure.

**/SYS**

Displays all active system parameters.

**/TTY**

Displays all parameters for terminal drivers.

## **Description**

SYSMAN displays parameters in decimal unless you specify the /HEX qualifier. ASCII values are always displayed in ASCII.

Abbreviations for parameter names must be unique because SYSMAN displays the first parameter matching the abbreviation. Ambiguity checks do not occur. For example, a specification of PARAMETERS SHOW GBL displays the GBLSECTIONS parameter. To display the GBLPAGFIL parameter, you must specify PARAMETERS SHOW GBLPAGF to avoid displaying the GBLPAGES parameter.

You can use a period (.) to indicate that you want to work with the system parameter that you specified in the last PARAMETERS SET or PARAMETERS SHOW command.

# SYSMAN PARAMETERS SHOW

## Examples

1. SYSMAN> PARAMETERS SHOW GBLSECTIONS  
Parameter Name    Current    Default    Minimum    Maximum Unit    Dynamic  
GBLSECTIONS        100        40        20        -1 Sections  
  
SYSMAN> PARAMETERS SET . 110  
SYSMAN> PARAMETERS SHOW .  
Parameter Name    Current    Default    Minimum    Maximum Unit    Dynamic  
GBLSECTIONS        110        40        20        -1 Sections

In this example, the user first displays the values of the GBLSECTIONS parameter and then refers to the parameter with a period to set its current value to 110. The next PARAMETERS SHOW command also uses the period notation to obtain confirmation that the change occurred.

2. SYSMAN> PARAMETERS SHOW/ACP

This command produces output similar to the following example:

```
Parameters in use: Active
Parameter Name        Current    Default    Minimum    Maximum Unit    Dynamic
ACP_MULTIPLE            0            1            0            1 Boolean        D
ACP_SHARE                1            1            0            1 Boolean        D
ACP_MAPCACHE            52            8            1            -1 Pages        D
ACP_HDRCACHE            138          128          2            -1 Pages        D
ACP_DIRCACHE            138          80            2            -1 Pages        D
ACP_DINDXCACHE          37            25            2            -1 Pages        D
ACP_WORKSET              0            0            0            -1 Pages        D
ACP_FIDCACHE            64            64            0            -1 File-Ids     D
ACP_EXTCACHE            64            64            0            -1 Extents      D
ACP_EXTLIMIT            300          300          0            1000 Percent/10 D
ACP_QUOCACHE            130          64            0            -1 Users        D
ACP_SYSACC                4            8            0            -1 Directories D
ACP_MAXREAD             32            32            1            64 Blocks       D
ACP_WINDOW               7            7            1            -1 Pointers     D
ACP_WRITEBACK            1            1            0            1 Boolean        D
ACP_DATACHECK            2            2            0            3 Bit-mask      D
ACP_BASEPRIO             8            8            4            31 Priority      D
ACP_SWAPFLGS            14            15            0            15 Bit-mask     D
ACP_XQP_RES               1            1            0            1 Boolean        D
ACP_REBLDSYS             0            1            0            1 Boolean        D
```

3. SYSMAN> PARAMETERS SHOW/ACP/HEX

This command produces a hexadecimal display of the values of the ACP system parameters.

## SYSMAN PARAMETERS SHOW

Parameters in use: Active

| Parameter Name | Current  | Default  | Minimum  | Maximum  | Unit        | Dynamic |
|----------------|----------|----------|----------|----------|-------------|---------|
| ACP_MULTIPLE   | 00000000 | 00000001 | 00000000 | 00000001 | Boolean     | D       |
| ACP_SHARE      | 00000001 | 00000001 | 00000000 | 00000001 | Boolean     |         |
| ACP_MAPCACHE   | 00000034 | 00000008 | 00000001 | FFFFFFFF | Pages       | D       |
| ACP_HDRCACHE   | 0000008A | 00000080 | 00000002 | FFFFFFFF | Pages       | D       |
| ACP_DIRCACHE   | 0000008A | 00000050 | 00000002 | FFFFFFFF | Pages       | D       |
| ACP_DNDXCACHE  | 00000025 | 00000019 | 00000002 | FFFFFFFF | Pages       | D       |
| ACP_WORKSET    | 00000000 | 00000000 | 00000000 | FFFFFFFF | Pages       | D       |
| ACP_FIDCACHE   | 00000040 | 00000040 | 00000000 | FFFFFFFF | File-Ids    | D       |
| ACP_EXTCACHE   | 00000040 | 00000040 | 00000000 | FFFFFFFF | Extents     | D       |
| ACP_EXTLIMIT   | 0000012C | 0000012C | 00000000 | 000003E8 | Percent/10  | D       |
| ACP_QUOCACHE   | 00000082 | 00000040 | 00000000 | FFFFFFFF | Users       | D       |
| ACP_SYSACC     | 00000004 | 00000008 | 00000000 | FFFFFFFF | Directories | D       |
| ACP_MAXREAD    | 00000020 | 00000020 | 00000001 | 00000040 | Blocks      | D       |
| ACP_WINDOW     | 00000007 | 00000007 | 00000001 | FFFFFFFF | Pointers    | D       |
| ACP_WRITEBACK  | 00000001 | 00000001 | 00000000 | 00000001 | Boolean     | D       |
| ACP_DATACHECK  | 00000002 | 00000002 | 00000000 | 00000003 | Bit-mask    | D       |
| ACP_BASEPRIO   | 00000008 | 00000008 | 00000004 | 0000001F | Priority    | D       |
| ACP_SWAPFLGS   | 0000000E | 0000000F | 00000000 | 0000000F | Bit-mask    | D       |
| ACP_XQP RES    | 00000001 | 00000001 | 00000000 | 00000001 | Boolean     |         |
| ACP_REBLDSYS   | 00000000 | 00000001 | 00000000 | 00000001 | Boolean     |         |

#### 4. SYSMAN> PARAMETERS SHOW/OBSOLETE

This command displays the names of all obsolete system parameters.

SYSMAN> PARAMETERS SHOW/OBSOLETE

Node XENON3: Parameters in use: ACTIVE

| Parameter Name   | Current    | Default    | Minimum | Maximum    | Unit     | Dynamic |
|------------------|------------|------------|---------|------------|----------|---------|
| VECTOR_PROC      | 1          | 1          | 0       | 3          | Obsolete |         |
| PAGFILCNT        | 0          | 0          | 0       | 0          | Obsolete |         |
| SWPFILCNT        | 0          | 0          | 0       | 0          | Obsolete |         |
| VIRTUALPAGECNT   | 2147483647 | 2147483647 | 2048    | 2147483647 | Obsolete |         |
| EXUSRSTK         | 1024       | 1024       | 1024    | -1         | Obsolete |         |
| QBUS_MULT_INTR   | 0          | 0          | 0       | 1          | Obsolete |         |
| LAMA_PREGS       | 0          | 0          | 0       | 255        | Obsolete |         |
| LOCKIDTBL_MAX    | 4251127    | 16776959   | 1792    | 16776959   | Obsolete |         |
| SCSCONNCNT       | 40         | 40         | 2       | 32767      | Obsolete |         |
| UDABURSTRATE     | 0          | 0          | 0       | 31         | Obsolete |         |
| SA_APP           | 0          | 0          | 0       | 1          | Obsolete |         |
| TAILORED         | 0          | 0          | 0       | 1          | Obsolete |         |
| BOOT_STYLE       | 0          | 0          | 0       | 2          | Obsolete |         |
| SD_ALLOCLASS     | 0          | 0          | 0       | 255        | Obsolete |         |
| NI_SCS_LAN_OVRHD | 0          | 0          | 0       | 256        | Obsolete |         |
| SERVED_IO        | 0          | 0          | 0       | 0          | Obsolete |         |
| XFMAXRATE        | 236        | 236        | 0       | 255        | Obsolete |         |

·  
·  
·

#### 5. SYSMAN> PARAMETERS SHOW <parameter\_name>

This command displays information about one obsolete system parameter, VIRTUALPAGECNT.

SYSMAN> PARAMETERS SHOW VIRT

```
%SYSMAN-I-NODERR, error returned from node XENON3
-SMI-E-NOSUCHPARM, no such parameter
```

## SYSMAN PARAMETERS SHOW

You must enter the full name of the parameter:

```
SYSMAN> PARAMETERS SHOW VIRTUALPAGECNT
```

```
Node XENON3: Parameters in use: ACTIVE
Parameter Name      Current      Default      Minimum      Maximum Unit  Dynamic
-----
VIRTUALPAGECNT     2147483647 2147483647   2048 2147483647 Obsolete
```

```
SYSMAN>
$
```

6. SYSMAN> PARAMETERS SHOW/STARTUP  
Startup command file = SYSS\$SYSTEM:STARTUP.COM

This command displays the name of the site-independent startup command procedure.

```
SYSMAN> PARAMETERS SHOW/PAUSE MAXPROCESSCNT
```

```
Node EXPERT: Parameters in use: ACTIVE
Parameter Name      Current      Default      Minimum      Maximum Unit  Dynamic
-----
MAXPROCESSCNT       160          32           12           8192 Processes
```

Press return to continue

```
Node MODERN: Parameters in use: ACTIVE
```

```
Parameter Name      Current      Default      Minimum      Maximum Unit  Dynamic
-----
MAXPROCESSCNT       157          32           12           8192 Processes
```

Press return to continue

```
Node IMPOSE: Parameters in use: ACTIVE
```

```
Parameter Name      Current      Default      Minimum      Maximum Unit  Dynamic
-----
MAXPROCESSCNT       50           32           12           8192 Processes
```

Press return to continue

.  
.  
.

The command in this example allows you to control the rate at which the information is displayed.



---

## PARAMETERS USE

Reads a set of system parameters into the work area for display or modification.

### Format

PARAMETERS USE source

### Parameter

#### source

The source of a system parameter file for data to be read into the work area. The source can be any of the following items:

**ACTIVE** Read parameters from memory. When you invoke SYSMAN, active values are in effect.

**CURRENT** Read parameters from the default system parameter file, which is the source for parameters when you boot the system. Using the current parameters requires read (R) access to the system parameters file.

- On Alpha systems, the file that contains current parameters is SYS\$SYSTEM:ALPHAVMSSYS.PAR.
- On Integrity servers, the file that contains current parameters is SYS\$SYSTEM:IA64VMSSYS.PAR.

**filespec** Read parameters from a previously created system parameter file. The default file type is .PAR. You need read access to the file.

**DEFAULT** Read a parameter set containing the default values for all parameters. These values are supplied with the operating system.

### Qualifiers

None.

### Description

Depending on the source you enter with the command, PARAMETERS USE activates the parameter values:

- Stored in memory (ACTIVE)
- Stored in the default boot parameter file (CURRENT)
- From another file (filespec)
- From the system default values (DEFAULT)

### Example

```
SYSMAN> PARAMETERS USE DEFAULT
SYSMAN> SET STARTUP_P1 "MIN"
```

The first command activates the default parameter values that are supplied with the operating system. The second command sets the STARTUP\_P1 system parameter to "minimum." This avoids starting all layered products on a system that is not tuned for them, which might cause the system to hang.

# SYSMAN PARAMETERS WRITE

---

## PARAMETERS WRITE

Writes the contents of the work area to memory, to disk, or to a file, depending on the destination that you specify.

### Format

PARAMETERS WRITE destination

### Parameter

#### destination

The destination of a new parameter file can be any of the following ones:

- |          |  |
|----------|--|
| ACTIVE   | Write parameters to memory. Using the ACTIVE parameter requires CMKRNL privilege.  |
| CURRENT  | Write parameters to the system parameters file, which contains the current parameters on disk. Using the current parameter requires write (W) access to the system parameters file. <ul style="list-style-type: none"><li>• On Alpha systems, the file that contains current parameters is SYS\$SYSTEM:ALPHAVMSSYS.PAR.</li><li>• On Integrity servers, the file that contains current parameters is SYS\$SYSTEM:IA64VMSSYS.PAR.</li></ul> |
| filespec | Write parameters to a file. The default file type is .PAR and you need write access to the file.   |

### Qualifiers

None.

### Description

The PARAMETERS WRITE command writes the system parameter values and the name of the site-independent startup command procedure from the work area to the active system in memory, the current system parameter file on disk, or your choice of a parameter file. You can write only dynamic parameter values to the active system.

Both the PARAMETERS WRITE ACTIVE and PARAMETERS WRITE CURRENT commands send a message to OPCOM to record the event.

### Examples

1. SYSMAN> PARAMETERS WRITE SYS\$SYSTEM:SPECIAL

This command creates a new parameter specification file.

2. SYSMAN> PARAMETERS WRITE CURRENT

This command modifies the current system parameter file on disk (SYS\$SYSTEM:ALPHAVMSSYS.PAR).

```
!***** ! PARAM-  
INSERT ! HELP on the individual parameters is taken from SYSGEN and ! is  
inserted here by the build procedures. Please do not edit the ! first comment line.  
!*****
```

## **RESERVED\_MEMORY ADD (Alpha and Integrity servers)**

On Alpha and Integrity servers, adds an entry to the Reserved Memory Registry data file. Changes and additions to the Reserved Memory Registry data file do not take effect until the next reboot of the system.

Use the RESERVED\_MEMORY ADD command to reserve an amount of physical memory that might be needed at a future time. Use the /ALLOCATE qualifier to set aside one or more blocks of physical memory during the boot process. Using the /ALLOCATE qualifier allows memory to be sufficiently contiguous and aligned to be used with granularity hints.

AUTOGEN processes the Reserved Memory Registry data file in its GETDATA phase. AUTOGEN takes the size of all entries into account when calculating system parameters that depend on the available amount of physical memory.

AUTOGEN uses the reservation size of all entries to calculate the initial size of the global page table unless the entry was specified as /NOGLOBAL\_SECTION.

For more information about the Reserved Memory Registry, refer to the *HP OpenVMS System Manager's Manual* and the *HP OpenVMS Programming Concepts Manual*.

### **Format**

```
RESERVED_MEMORY ADD name
```

### **Parameter**

#### **name**

Name of the memory reservation. You must specify a name.

If the reservation is for a memory resident global section, the name of the reservation must be the same as the global section name.

### **Qualifiers**

#### **/ALLOCATE**

#### **/NOALLOCATE (default)**

Allocates pages during the next reboot of the system. The physical alignment of the pages is based on the maximum granularity hint factor that can be used to map the pages without exceeding the size of the memory reservation. (See the introduction to this section for more information about the /ALLOCATE qualifier.)

Possible granularity hint factors are 512 pages (or 4 MB) and 64 pages (or 512 KB). Therefore, assuming an 8 KB system page size, reserved memory is physically aligned as follows:

- size  $\geq$  4 MB: physically aligned on a 4 MB boundary
- size  $<$  4 MB: physically aligned on a 512 KB boundary

If you specify /NOALLOCATE, or do not specify /ALLOCATE, memory is reserved only by reducing the system's fluid page count, but no specific pages are set aside.

#### **/GLOBAL\_SECTION (default)**

#### **/NOGLOBAL\_SECTION**

/NOGLOBAL\_SECTION indicates that the memory qualifier is for a privileged application instead of a group or system global section. (/GLOBAL\_SECTION

## **SYSMAN RESERVED\_MEMORY ADD (Alpha and Integrity servers)**

indicates that the memory qualifier is for a group or system global section.) You cannot use /NOGLOBAL\_SECTION with the qualifiers /GROUP, /SYSGBL, or /PAGE\_TABLES.

### **/GROUP=*n***

Establishes that the reserved memory is for a group global section. The value *n* specifies the UIC group number (in octal) of the process that creates the group global section. Only processes within the creator's UIC group number are allowed access to the global section. For example, if a process with the UIC of [6,100] is the creator of the group global section, the group number for the /GROUP qualifier is 6.

You cannot use the /GROUP qualifier with either /SYSGBL or /NOGLOBAL\_SECTION qualifiers.

### **/PAGE\_TABLES (default)**

#### **/NOPAGE\_TABLES**

Reserves additional memory for shared page tables. When the memory-resident global section is created, shared page tables are created for the global section. If you do not specify /ALLOCATE (or if you specify /NOALLOCATE), the additional reserved memory is deducted only from the system's fluid page count. If you specify /ALLOCATE, additional pages are allocated for the shared page table during the next reboot of the system, and the additional reserved memory is deducted from the system's fluid page count.

If you do not specify /PAGE\_TABLES, or if you specify /NOPAGE\_TABLES, additional memory is not reserved for shared page tables. When the memory-resident global section is created, shared page tables are not created for the global section.

### **/RAD=*n***

Specifies the preferred resource affinity domain (RAD) for the reservation you want to make. The value of *n* is the number of the RAD you specify. If you omit this qualifier, or if this RAD does not have sufficient memory, any other RAD can satisfy the reservation request, and the first available memory section will be used.

The /ALLOCATE qualifier is enforced implicitly when you specify a RAD.

For an example procedure that shows how to use SYSMAN RAD qualifiers and options, see Section 9.4.

### **/SIZE=*size of reserved memory, in MBs***

Specifies the number of megabytes to be deducted from the system's fluid page count for this memory-resident global section when the VMS\$RESERVED\_MEMORY.DATA data file is read during system initialization.

### **/SYSGBL**

Indicates that a reservation is for a system global memory-resident section.

You cannot combine this qualifier with the /GROUP or /NOGLOBAL\_SECTION qualifier. This qualifier is the default unless you specify /GROUP or /NOGLOBAL\_SECTION.

### **/ZERO**

#### **/NOZERO (default)**

/ZERO implies /ALLOCATE. If you specify /ZERO, preallocated pages are zeroed during system initialization. Zeroed pages are required for memory-resident

## SYSMAN

# RESERVED\_MEMORY ADD (Alpha and Integrity servers)

global sections; however, the pages do not need to be zeroed during system initialization.

`/NOALLOCATE` implies `/NOZERO` because `/ZERO` is incompatible with `/NOALLOCATE`. If you do not specify `/ZERO`, or if you specify `/NOZERO`, preallocated pages are not zeroed during system initialization. Instead, these pages are zeroed when the global section is created.

## Description

The OpenVMS operating system allows you to reserve non-fluid memory for use within a memory-resident global demand-zero section. The reserved memory can be simply a deduction from the system's fluid memory size, or it can be preallocated as physical pages.

Using the Reserved Memory Registry ensures that AUTOGEN tunes the system properly not to include memory-resident section pages in its calculation of the system's fluid page count. AUTOGEN sizes the system page file, the number of process, and the working set maximum size based on the system's fluid page count. A system can experience severe performance problems if AUTOGEN adjusts parameters based on a fluid page count that does not account for the physical memory that is permanently reserved for some other purpose.

Using the Reserved Memory Registry also ensures that memory is available for memory-resident sections when the `allocate` option is used.

Users of reserved, non-fluid memory enter the characteristics of the memory into a data file that is read during the system initialization (boot-time). The file is called `SYS$SYSTEM:VMS$RESERVED_MEMORY.DATA`, and you use the `SYSMAN` utility to maintain it.

---

### Note

---

Do not edit the `SYS$SYSTEM:VMS$RESERVED_MEMORY.DATA` data file.

---

`VMS$RESERVED_MEMORY.DATA` is read during system initialization. For each entry in this data file, the number of megabytes is deducted from the system's fluid page count for this memory-resident global section as specified by the `/SIZE` qualifier on the `RESERVED_MEMORY ADD` command. If `/PAGE_TABLES` was specified, the amount of memory required for the shared page tables mapping the memory-resident global section is deducted from the system's fluid page count as well.

The following table summarizes the effects of qualifiers on the `RESERVED_MEMORY ADD` command:

## SYSMAN RESERVED\_MEMORY ADD (Alpha and Integrity servers)

| Qualifier    | Effect   |
|--------------|--|
| /ALLOCATE    | A block of physical pages is also allocated and set aside for the memory-resident global section.  |
| /PAGE_TABLES | An additional block of physical pages is allocated and set aside for the shared page tables. The pages have a physical alignment appropriate to use the largest granularity hint factor for the block. |
| /ZERO        | The pages are zeroed during system initialization or when the system is idle.  |
| /NOZERO      | The pages are zeroed when the memory-resident global section is created.   |

If you set the system parameter `STARTUP_P1` to “MIN”, entries in the Reserved Memory Registry are ignored, and memory is not reserved.

During system initialization while processing the Reserved Memory Registry data file, if the system encounters errors reserving fluid pages or allocating physical pages, it issues a warning to the console, and the system continues to boot; the request, however, is not granted.

### Example

```
SYSMAN> RESERVED_MEMORY ADD DFW$GS_1 /NOPAGE /GROUP=100 /SIZE=1
SYSMAN> RESERVED_MEMORY ADD DFW$GS_2 /PAGE /SIZE=2 /ALLOC /ZERO
SYSMAN> RESERVED_MEMORY ADD DFW$GS_3 /PAGE /SIZE=3
```

The commands in this example add entries to the Reserved Memory Registry data file. (The example for the `RESERVED_MEMORY SHOW` command displays the values for these entries.)

## **RESERVED\_MEMORY EXTEND (Alpha and Integrity servers)**

On Alpha and Integrity servers, adds sections of memory if you want to specify more than one resource affinity domain (RAD) for a single reservation.

EXTEND does not allow you to specify any of the /ALLOCATE, /ZERO, or /PAGE\_TABLES flags. The existing reservation determines the state of these flags. The /ALLOCATE flag is set implicitly with EXTEND, whether or not it was set for the initial reservation.

To add a memory section without specifying a RAD, use the /NORAD qualifier.

Refer to Section 9.4 for an example procedure that shows how to use SYSMAN RAD qualifiers and options.

### **Format**

```
RESERVED_MEMORY EXTEND name
```

### **Parameter**

#### **name**

Name of the memory reservation. You must specify a name.

If the reservation is for a memory resident global section, the name of the reservation must be the same as the global section name.

### **Qualifiers**

#### **/RAD=n**

#### **/NORAD**

Specifies an additional memory section if you want to specify more than one RAD for a single reservation.

Use /NORAD to add a memory section without specifying a RAD.

#### **/SIZE=size of reserved memory, in MBs**

Specifies the number of megabytes to be deducted from the system's fluid page count for this memory-resident global section when the VMS\$RESERVED\_MEMORY.DATA data file is read during system initialization.

## **SYSMAN RESERVED\_MEMORY FREE (Alpha and Integrity servers)**

---

### **RESERVED\_MEMORY FREE (Alpha and Integrity servers)**

On a running Alpha or Integrity servers, frees reserved memory. This command does not affect the contents of the Reserved Memory Registry data file; it affects only the running system.

#### **Format**

RESERVED\_MEMORY FREE name

#### **Parameter**

**name**

Name of the memory reservation. You must specify a name.

#### **Qualifiers**

**/GLOBAL\_SECTION (default)**

**/NOGLOBAL\_SECTION**

**/NOGLOBAL\_SECTION** indicates that the memory qualifier is for a privileged application instead of a group or system global section. (**/GLOBAL\_SECTION** indicates that the memory qualifier is for a group or system global section.) You cannot use **/NOGLOBAL\_SECTION** with the qualifiers **/GROUP**, **/SYSGBL**, or **/PAGE\_TABLES**.

**/GROUP=*n***

You must specify **/GROUP** if the memory-resident global section is a group global section. Do not specify **/GROUP** if the memory-resident global section is a system global section. The value *n* is the UIC group number (in octal) associated with the memory-resident being freed.

You cannot use the **/GROUP** qualifier with either **/SYSGBL** or **/NOGLOBAL\_SECTION** qualifiers.

**/SYSGBL**

Indicates that a reservation is for a system global, memory-resident section.

You cannot combine this qualifier with the **/GROUP** or **/NOGLOBAL\_SECTION** qualifier. This qualifier is the default unless you specify **/GROUP** or **/NOGLOBAL\_SECTION**.

#### **Description**

If physical pages were not preallocated during system initialization for this global section, the reserved memory is simply added to the system's fluid page count. Otherwise, the pages are deallocated to the system's free or zeroed page list.

If page tables are also reserved for the named memory-resident global section, the reserved memory for the shared page tables is also freed. If part of the named reservation is still used, the amount of reserved memory not currently in use is freed. The system displays an informational message that indicates if the named global section is using some portion of the reserved memory.



## SYSMAN RESERVED\_MEMORY FREE (Alpha and Integrity servers)

### Example

```
SYSMAN> RESERVED_MEMORY FREE DFW$GS_2
%SMI-S-RMRFREPAG, pages successfully freed from reservation
SYSMAN> RESERVED_MEMORY SHOW
%SYSMAN-I-OUTPUT, command execution on node PIPERI
Name                Pages  In Use Group   PTs  Allocated Zeroed
DFW$GS_3            384      0 SYSGBL    No   No       No
DFW$GS_1            128      0 00000100  No   No       No
DFW$GS_3              1      0 SYSGBL    Yes  No       No
```

In this example, the first command frees reserved memory in DFW\$GS\_2. The second command displays reserved memory in the running system for DFW\$GS\_3 and DFW\$GS\_1, but not for DFW\$GS\_2, which has no reserved memory.

## **SYSMAN RESERVED\_MEMORY LIST (Alpha and Integrity servers)**

---

### **RESERVED\_MEMORY LIST (Alpha and Integrity servers)**

On Alpha and Integrity servers, provides a preview of this reservation as it is currently stored in the Reserved Memory Registry data file. If no reservation is specified, all current reservations are displayed.

Use this qualifier to ensure that a reservation will be made as intended.

Refer to Section 9.4 for an example procedure that shows how to use SYSMAN resource affinity domain RAD qualifiers and options.

#### **Format**

```
RESERVED_MEMORY LIST name
```

#### **Parameter**

##### **name**

Name of the reservation you want to verify in the Reserved Memory Registry data file.

#### **Qualifiers**

##### **/GLOBAL\_SECTION (default)**

##### **/NOGLOBAL\_SECTION**

`/NOGLOBAL_SECTION` indicates that the memory qualifier is for a privileged application instead of a group or system global section. (`/GLOBAL_SECTION` indicates that the memory qualifier is for a group or system global section.) You cannot use `/NOGLOBAL_SECTION` with the qualifiers `/GROUP`, `/SYSGBL`, or `/PAGE_TABLES`.

##### **/GROUP=*n***

You must specify `/GROUP` if the memory-resident global section is a group global section. Do not specify `/GROUP` if the memory-resident global section is a system global section. The value *n* is the UIC group number (in octal) associated with the memory-resident being freed.

You cannot use the `/GROUP` qualifier with either `/SYSGBL` or `/NOGLOBAL_SECTION` qualifiers.

##### **/SYSGBL**

Indicates that a reservation is for a system global, memory-resident section.

You cannot combine this qualifier with the `/GROUP` or `/NOGLOBAL_SECTION` qualifier. This qualifier is the default unless you specify `/GROUP` or `/NOGLOBAL_SECTION`.

## **RESERVED\_MEMORY MODIFY (Alpha and Integrity servers)**

On Alpha and Integrity servers, allows you to modify an existing entry in the Reserved Memory Registry data file.

Refer to Section 9.4 for an example procedure that shows how to use SYSMAN RAD qualifiers and options.

### **Format**

```
RESERVED_MEMORY MODIFY name
```

### **Parameter**

#### **name**

Name associated with the entry being removed. You must specify a name.

### **Qualifiers**

#### **/ALLOCATE**

#### **/NOALLOCATE (default)**

Allocates pages during the next reboot of the system as specified on the command line. (The default is taken from the existing Reserved Memory Registry entry.) The physical alignment of the pages is based on the maximum granularity hint factor that can be used to map the pages depending on the size of the reserved memory.

Possible granularity hint factors are 512 pages (or 4 MB) and 64 pages (or 512 KB). Therefore, assuming an 8-KB system page size, reserved memory is physically aligned as follows:

- size  $\geq$  4 MB: physically aligned on a 4-MB boundary
- size  $<$  4 MB: physically aligned on a 512-KB boundary

If you specify **/NOALLOCATE**, or if you do not specify **/ALLOCATE**, memory is reserved only by reducing the system's fluid page count, but no specific pages are set aside.

#### **/GLOBAL\_SECTION (default)**

#### **/NOGLOBAL\_SECTION**

**/NOGLOBAL\_SECTION** indicates that the memory qualifier is for a privileged application instead of a group or system global section. (**/GLOBAL\_SECTION** indicates that the memory qualifier is for a group or system global section.) You cannot use **/NOGLOBAL\_SECTION** with the qualifiers **/GROUP**, **/SYSGBL**, or **/PAGE\_TABLES**.

#### **/GROUP=*n***

Establishes that the reserved memory is for a group global section. The value *n* specifies the UIC group number (in octal) of the process that creates the group global section. Only processes within the creator's UIC group number are allowed access to the global section. For example, if a process with the UIC of [6,100] is the creator of the group global section, the group number for the **/GROUP** qualifier is 6.

You cannot use the **/GROUP** qualifier with either **/SYSGBL** or **/NOGLOBAL\_SECTION** qualifiers.

## **SYSMAN RESERVED\_MEMORY MODIFY (Alpha and Integrity servers)**

**/NEW\_RAD=*nn***

**/NONEW\_RAD**

Use **NEW\_RAD** to change the RAD assignment for an entry. Do this by first specifying **/RAD=*n*** to identify the entry you want to change and then specify **/NEW\_RAD=*nn*** to identify the new RAD. Use only **/NEW\_RAD=*nn*** (without the **/RAD** qualifier) if the old entry did not have a RAD assigned.

**/PAGE\_TABLES (default)**

**/NOPAGE\_TABLES**

Reserves additional memory for shared page tables system as specified on the command line. (The default is taken from the existing Memory Registry.)

When the memory-resident global section is created, shared page tables are created for the global section. If you do not specify **/ALLOCATE**, or if you specify **/NOALLOCATE**, the additional reserved memory is deducted from the system's fluid page count. If you specify **/ALLOCATE**, additional pages are allocated for the shared page table during the next reboot of the system, and the additional reserved memory is deducted from the system's fluid page count.

If you do not specify **/PAGE\_TABLES**, or if you specify **/NOPAGE\_TABLES**, additional memory is not reserved for shared page tables. When the memory-resident global section is created, shared page tables are not created for the global section.

You cannot specify **/PAGE\_TABLES** if the reservation has the attribute **/NOGLOBAL\_SECTION**.

**/RAD=*n***

**/NORAD**

**MODIFY/RAD=*n*** affects only the entry for the specified resource affinity domain (RAD). The value of *n* is the RAD you specify.

### **Usage Rules**

- Do not use **MODIFY/RAD=*n*** to change the size of a reservation for an entry without a specified number or to change the state of the **/ZERO** or **/PAGE\_TABLES** flags. (Flags are always consistent for all entries in a given reservation.)
- To change the RAD assignment for an entry, specify **/RAD=*n*** to identify the entry you want to change and **/NEW\_RAD=*nn*** to identify the new RAD. Use only **/NEW\_RAD=*nn*** (without the **/RAD** qualifier) if the old entry did not have a RAD assigned.
- Use **MODIFY *name* /NORAD** if you no longer want to tie memory for this reservation to any specific RADs. **SYSMAN** compresses multiple entries into a single entry for an unspecified RAD with the total memory size as the sum of all RAD entries for this reservation.

**/SIZE=*size of reserved memory, in MBs***

Specifies the number of megabytes to be deducted from the system's fluid page count for this memory-resident global section when the **VMS\$RESERVED\_MEMORY.DATA** data file is read during system initialization. The default value for **/SIZE** is taken from the existing Reserved Memory Registry.

**/SYSGBL**

Indicates that a reservation is for a system global memory resident section.

## SYSMAN

# RESERVED\_MEMORY MODIFY (Alpha and Integrity servers)

You cannot combine this qualifier with the /GROUP or /NOGLOBAL\_SECTION qualifier. This qualifier is the default unless you specify /GROUP or /NOGLOBAL\_SECTION.

### **/ZERO**

#### **/NOZERO (default)**

/ZERO implies /ALLOCATE. If you specify /ZERO, preallocated pages are zeroed during system initialization. Zeroed pages are required for memory-resident global sections; however, the pages do not need to be zeroed during system initialization. The default value is taken from existing Reserved Memory Registry entry.

/NOALLOCATE implies /NOZERO because /ZERO is incompatible with /NOALLOCATE. If you do not specify /ZERO, or if you specify /NOZERO, preallocated pages are not zeroed during system initialization. Instead, these pages are zeroed when the global section is created.

## **Description**

The Reserved Memory Registry entry to be modified is identified by the combination of the following items:

```
name
/[NO]GLOBAL_SECTION
/GROUP=n
/SYSGBL
```

The values of these qualifiers are the same as for the RESERVED\_MEMORY ADD command.

## **Example**

```
SYSMAN> RESERVED_MEMORY MODIFY
X234567890123456789012345678901/SIZ=2/ZERO
$ TYPE SYS$SYSTEM:VMS$RESERVED_MEMORY.DATA
! VMS$RESERVED_MEMORY.DATA
! Do NOT edit this file
! Modify with SYSMAN RESERVED_MEMORY commands
! A = /ALLOCATE, Z = /ZERO, P = /PAGE_TABLES, VERSION = 1
! SIZE (MB) RESERVATION NAME GROUP A Z P
1 X23456789012345678901234567890 1 0 0 1
2 X234567890123456789012345678901 SYSGBL 1 1 1
1 X2345678901234567890123456789012 NOGBL 0 0 0
SYSMAN> EXIT
$
```

The command in this example modifies an entry to reserve 2 MB of memory and to allocate and zero this memory at boot time.

## SYSMAN RESERVED\_MEMORY REMOVE (Alpha and Integrity servers)

---

### RESERVED\_MEMORY REMOVE (Alpha and Integrity servers)

On Alpha and Integrity servers, removes a reserved memory entry from the Reserved Memory Registry data file. This command takes effect on the next reboot and does not affect the running systems.

#### Format

```
RESERVED_MEMORY REMOVE name
```

#### Parameter

##### **name**

Name associated with the entry being removed. You must specify a name.

If page tables are reserved for the named memory-resident global section, the additional reserved memory is also removed.

#### Qualifiers

##### **/GLOBAL\_SECTION (default)**

##### **/NOGLOBAL\_SECTION**

**/NOGLOBAL\_SECTION** indicates that the memory qualifier is for a privileged application instead of a group or system global section. (**/GLOBAL\_SECTION** indicates that the memory qualifier is for a group or system global section.) You cannot use **/NOGLOBAL\_SECTION** with the qualifiers **/GROUP**, **/SYSGBL**, or **/PAGE\_TABLES**.

##### **/GROUP=*n***

You must specify **/GROUP** if the memory-resident global section is a group global section. Do not specify **/GROUP** if the memory-resident global section is a system global section. The value *n* is the UIC group number (in octal) associated with the memory-resident section being removed. You cannot use the **/GROUP** qualifier with either **/SYSGBL** or **/NOGLOBAL\_SECTION** parameters.

##### **/SYSGBL**

Indicates that a reservation is for a system global memory resident section.

You cannot combine this qualifier with the **/GROUP** or **/NOGLOBAL\_SECTION** qualifier. This qualifier is the default unless you specify **/GROUP** or **/NOGLOBAL\_SECTION**.

#### Example

```
SYSMAN> RESERVED_MEMORY ADD DFW$GS1/SIZE=1  
SYSMAN> RESERVED_MEMORY REMOVE DFW$GS1
```

The first command in this example adds DFW\$GS1; the second command removes it.

## RESERVED\_MEMORY SHOW (Alpha and Integrity servers)

On Alpha and Integrity servers, displays the memory reservations on the running system.

The display includes how much of the reserved memory is currently in use by the named global section. It also includes how much memory is reserved and currently in use for page tables, if any, and the blocks of physical pages reserved.

### Format

```
RESERVED_MEMORY SHOW name
```

### Parameter

#### **name**

Name associated with the entry being displayed within the running system. If you do not specify a *name*, the system displays the reserved memory for all registered global sections.

### Qualifiers

#### **/GLOBAL\_SECTION (default)**

#### **/NOGLOBAL\_SECTION**

**/NOGLOBAL\_SECTION** indicates that the memory qualifier is for a privileged application instead of a group or system global section. (**/GLOBAL\_SECTION** indicates that the memory qualifier is for a group or system global section.) You cannot use **/NOGLOBAL\_SECTION** with the qualifiers **/GROUP**, **/SYSGBL**, or **/PAGE\_TABLES**.

#### **/GROUP=*n***

You must specify **/GROUP** if the memory-resident global section is a group global section. Do not specify **/GROUP** if the memory-resident global section is a system global section. The value *n* is the UIC group number (in octal) associated with the memory-resident section being displayed. You can use the **/GROUP** qualifier only if you specify *name*. You cannot use the **/GROUP** qualifier with either **/SYSGBL** or **/NOGLOBAL\_SECTION** parameters.

#### **/SYSGBL**

Indicates that a reservation is for a system global memory resident section.

You cannot combine this qualifier with the **/GROUP** or **/NOGLOBAL\_SECTION** qualifier. This qualifier is the default unless you specify **/GROUP** or **/NOGLOBAL\_SECTION**.

### Example

```
SYSMAN> RESERVED_MEMORY SHOW
%SYSMAN-I-OUTPUT, command execution on node PIPER
Name           Pages  In Use Group  PTs  Allocated Zeroed
DFW$GS_3       384      0 SYSGBL  No  No      No
DFW$GS_2       256      0 SYSGBL  No  Yes     Yes
DFW$GS_1       128      0 0000100 No  No      No
DFW$GS_3         1      0 SYSGBL  Yes No      No
DFW$GS_2         1      0 SYSGBL  Yes Yes     No
```

**SYSMAN  
RESERVED\_MEMORY SHOW (Alpha and Integrity servers)**

The command in this example displays the memory reservations on a running system.



---

## SET ENVIRONMENT

Defines the nodes or cluster to which subsequent commands apply.

Requires OPER or SETPRV privilege on all nodes in the target environment.

### Format

SET ENVIRONMENT

### Parameters

None.

### Qualifiers

#### **/CLUSTER**

Specifies that all subsequent commands apply to all nodes in the cluster. By default, the management environment is the local cluster. Specify a nonlocal cluster by naming one cluster member with the /NODE qualifier.

#### **/NODE=(node1,node2,...)**

Specifies that SYSMAN execute subsequent commands on the given DECnet nodes. If accompanied by the /CLUSTER qualifier, the environment becomes the cluster where the given DECnet node is a member. A node name can be a system name, cluster alias, or logical name. However, before you can use logical names to define the command environment, you must set up the logical name table SYSMAN\$NODE\_TABLE. For more information about defining the SYSMAN logical name table, see the *HP OpenVMS System Manager's Manual*.

#### **/USERNAME=username**

Specifies that this user name should be used for access control purposes on another node. You can use this qualifier only in conjunction with the /CLUSTER or /NODE qualifiers. SYSMAN uses the current user name if none is supplied. SYSMAN prompts for a password whenever you specify a new user name.

---

#### **Note**

---

The account specified must have only a primary password. Accounts with secondary passwords are not supported.

---

### Description

The SET ENVIRONMENT command defines the target nodes or cluster for subsequent commands. When invoked, the system management environment is the local node where you are running SYSMAN. You can change the environment to any other nodes in the cluster, the entire cluster, or any nodes or cluster available through DECnet.

Designate an OpenVMS Cluster environment with the /CLUSTER qualifier. When specifying a nonlocal cluster, also include the /NODE qualifier to identify the cluster.

## **SYSMAN SET ENVIRONMENT**

If your environment consists of Vax, Alpha, and Integrity server nodes, see the DO command for information about creating logicals to manage each platform as an environment.

You can display the current environment with the command SHOW ENVIRONMENT. To adjust privileges and defaults for the current environment, use the SET PROFILE command.

An environment exists until you exit from SYSMAN or establish another command context with the SET ENVIRONMENT command.

### **Examples**

1. SYSMAN> SET ENVIRONMENT/CLUSTER  
%SYSMAN-I-ENV, Current command environment:  
Clusterwide on local cluster  
Username ALEXIS will be used on nonlocal nodes

This command defines the command environment as the local cluster. SYSMAN confirms the new environment.

2. SYSMAN> SET ENVIRONMENT/NODE=NODE21/CLUSTER  
Remote Password:  
%SYSMAN-I-ENV, Current command environment:  
Clusterwide on remote node NODE21  
Username ALEXIS will be used on nonlocal nodes

This command establishes a management environment on the cluster where NODE21 is a member. SYSMAN prompts for a password because it is a nonlocal environment.

3. SYSMAN> SET ENVIRONMENT/NODE=(NODE21,NODE22,NODE23)  
%SYSMAN-I-ENV, Current command environment:  
Individual nodes: NODE21,NODE22,NODE23  
Username ALEXIS will be used on nonlocal nodes

This command defines the management environment to be three individual nodes.

4. \$ CREATE/NAME TABLE/PARENT=LNMSYSTEM\_DIRECTORY -  
\$ SYSMAN\$NODE TABLE  
§ DEFINE LAVCS SYS1,SYS2,SYS3,SYS4/TABLE=SYSMAN\$NODE\_TABLE  
\$ RUN SYSSYSTEM:SYSMAN  
SYSMAN> SET ENVIRONMENT/NODE=(LAVCS)  
%SYSMAN-I-ENV, Current command environment:  
Individual nodes: SYS1,SYS2,SYS3,SYS4  
Username ALEXIS will be used on nonlocal nodes

The commands in this example set up the logical name table SYSMAN\$NODE\_TABLE, define a logical name (LAVCS), and use the logical name to define the command environment.

---

## SET PROFILE

Temporarily modifies a user's current privileges and default device and directory.

### Format

SET PROFILE

### Parameters

None.

### Qualifiers

**/DEFAULT=device:[directory]**

Specifies the default disk device and directory name that the system should use in this environment to locate and catalog files.

**/PRIVILEGES=(priv1,priv2...)**

Specifies the privileges to add to the current privileges. Any enhanced privileges must be authorized.

**/VERIFY**

**/NOVERIFY (default)**

Specifies whether you want DCL verification (both procedure and image) for future DO commands.

### Description

The SET PROFILE command modifies process attributes for the current management environment. After considering the privilege requirements of commands that you intend to use in an environment, you can add or delete current privileges, if they are authorized. You can also set a new default device and directory, as well as use the SET PROFILE/[NO]VERIFY command to control DCL command verification in SYSMAN. Other attributes of your process remain constant. The profile is in effect until you change it, reset the environment, or exit from SYSMAN. The *HP OpenVMS System Manager's Manual* discusses profile changes in more detail.

### Examples

1. SYSMAN> SET PROFILE/DEFAULT=WORK1:[ALEXIS]

This command changes the default device and directory in the user account to directory ALEXIS on device WORK1.

2. SYSMAN> SET PROFILE/PRIVILEGES=(SYSPRV,CMKRNL)/VERIFY

This command makes the authorized privileges, SYSPRV and CMKRNL, part of the current privileges, and turns on DCL verification. The privileges remain in effect until the environment changes, you enter another SET PROFILE command, or you exit.

# SYSMAN SET TIMEOUT

---

## SET TIMEOUT

Establishes the amount of time SYSMAN waits for a node to respond. Once the time limit expires, SYSMAN proceeds to execute the command on the next node in the environment.

### Format

```
SET TIMEOUT time
```

### Parameter

#### **time**

Specifies a delta time value, which has the following format:

```
hh:mm:ss[.cc.]
```

This is the amount of time that SYSMAN waits for a node to respond. SYSMAN waits indefinitely—by default it has no timeout period. Refer to the *OpenVMS User's Manual* for a description of delta time values.

### Qualifiers

None.

### Example

```
SYSMAN> SET TIMEOUT 00:00:30
%SYSMAN-I-TIMEVAL, timeout value is 00:00:30
SYSMAN> CONFIGURATION SHOW TIME
System time on node NODE21: 19-JUN-2002 14:22:33
%SYSMAN-I-NODERR, error returned from node NODE22
%SMI-E-TIMEOUT, remote operation has timed out
System time on node NODE23: 19-JUN-2002 14:23:15
```

This command establishes a timeout period of 30 seconds. Because NODE22 did not respond within 30 seconds, SYSMAN displays an error message and proceeds to execute the command on the next node in the environment.

---

## **SHOW ENVIRONMENT**

Displays the target nodes or cluster where SYSMAN is executing commands.

### **Format**

SHOW ENVIRONMENT

### **Parameters**

None.

### **Qualifiers**

None.

### **Description**

The SHOW ENVIRONMENT command displays the current management environment. It can be the local cluster, local or remote nodes, or a nonlocal cluster. SYSMAN indicates if the environment is limited to individual nodes or if it is clusterwide. It also shows the current user name.

The environment exists until you exit from SYSMAN or enter another SET ENVIRONMENT command.

### **Examples**

1. SYSMAN> SHOW ENVIRONMENT  
%SYSMAN-I-ENV, Current command environment:  
Clusterwide on local cluster  
Username ALEXIS will be used on nonlocal nodes

This command shows the current environment is the local cluster. User name ALEXIS will be used on other nodes in the cluster.

2. SYSMAN> SHOW ENVIRONMENT  
%SYSMAN-I-ENV, Current command environment:  
Clusterwide on remote cluster NODE21  
Username ALEXIS will be used on nonlocal nodes

This command shows that the command environment is a nonlocal cluster where NODE21 is a member.

3. SYSMAN> SHOW ENVIRONMENT  
%SYSMAN-I-ENV, Current command environment:  
Individual nodes: NODE22,NODE23  
At least one node is not in local cluster  
Username ALEXIS will be used on nonlocal nodes

This command shows that the command environment consists of two nodes.

## **SYSMAN SHOW KEY**

---

### **SHOW KEY**

Displays key definitions created with the **DEFINE/KEY** command.

#### **Format**

```
SHOW KEY [key-name]
```

#### **Parameter**

##### **key-name**

Specifies the name of the key whose definition you want displayed. See the **DEFINE/KEY** command for a list of valid key names.

#### **Qualifiers**

##### **/ALL**

Displays all the key definitions in the specified state or states. Specifying a key name is not necessary.

##### **/BRIEF**

Displays only the key definition. By default, the system displays all the qualifiers associated with the key definition, including any specified state, unless you use the **/BRIEF** qualifier.

##### **/DIRECTORY**

Displays the names of all the states for which you have defined keys. If you have not defined keys, the **SHOW KEY/DIRECTORY** command displays the **DEFAULT** and **GOLD** states (which is the default **SYSMAN** keypad).

##### **/STATE=(state, state...)**

Specifies the name of a state for which the specified key definitions are to be displayed. If you select more than one state name, separate them with commas and enclose the list in parentheses.

#### **Description**

Specifies the name of the key whose definition you want displayed. See the **DEFINE/KEY** command for a list of valid key names.

#### **Example**

```
SYSMAN> SHOW KEY/ALL  
DEFAULT keypad definitions:  
  KP0 = "SHOW ENVIRONMENT" (echo)  
  KP1 = "SHOW PROFILE" (echo)  
SYSMAN>
```

This command displays all the key definitions currently in effect.

---

## **SHOW PROFILE**

Displays the privileges and the default device and directory being used in the current environment.

### **Format**

SHOW PROFILE

### **Parameters**

None.

### **Qualifiers**

#### **/DEFAULT**

Displays the default disk device and directory name that the system uses in this environment to locate and catalog files.

#### **/PRIVILEGES**

Displays only the privileges in effect for the current environment.

### **Description**

The SHOW PROFILE command displays the privileges and the default device and directory that is being used in the current environment. You can modify these attributes with the SET PROFILE command.

These values remain in effect until you change environments or enter another SET PROFILE command.

### **Example**

```
SYSMAN> SHOW PROFILE
%SYSMAN-I-DEFDIR, Default directory on node NODE21 -- WORK1:[BERGERON]
%SYSMAN-I-DEFPRIV, Process privileges on node NODE21 --
    TMPMGX
    OPER
    NETMBX
    SYSPRV
```

This command shows the default device and directory as well as current privileges.

## **SYSMAN SHOW TIMEOUT**

---

### **SHOW TIMEOUT**

Displays the amount of time SYSMAN waits for a node to respond. By default, there is no timeout period.

#### **Format**

SHOW TIMEOUT

#### **Parameters**

None.

#### **Qualifiers**

None.

#### **Example**

```
SYSMAN> SHOW TIMEOUT  
%SYSMAN-I-TIMEVAL, timeout value is 00:00:04.00
```

This command displays the current timeout value, which is 4 seconds.



---

## **SHUTDOWN NODE**

Shuts down one or more nodes in an OpenVMS Cluster.

The SHUTDOWN NODE command invokes SYS\$SYSTEM:SHUTDOWN to shut down one node or multiple nodes, as you specify, in the current management environment. You can enter the shutdown command in one command line, instead of executing the SHUTDOWN.COM procedure on each node individually.

Requires SETPRV privilege or all of the following privileges: CMKRNL, EXQUOTA, LOG\_IO, OPER, SYSNAM, SYSPRV, TMPMBX, WORLD.

### **Format**

SHUTDOWN NODE

### **Parameters**

None.

### **Qualifiers**

#### **/AUTOMATIC\_REBOOT**

#### **/NOAUTOMATIC\_REBOOT (default)**

Reboots the system automatically when the shutdown is complete.

#### **/CLUSTER\_SHUTDOWN**

#### **/NOCLUSTER\_SHUTDOWN (default)**

Shuts down the entire cluster.

When you use the /CLUSTER\_SHUTDOWN qualifier, each node suspends activity just short of shutting down completely, until all other nodes in the cluster have reached the same point in the shutdown procedure.

You must specify this option on every cluster node. If any one node is not shut down completely, the clusterwide shutdown cannot occur.

You should use the SET ENVIRONMENT/CLUSTER command before you issue a SHUTDOWN NODE/CLUSTER\_SHUTDOWN command to ensure that all nodes in the cluster are shutting down.

#### **/DISABLE\_AUTOSTART**

Specifies the number of minutes before shutdown when autostart queues running on the node are marked stop pending and are subject to failover to another node.

Using this qualifier gives you control over when the autostart failover process begins. By default, the value equals that of the /MINUTES\_TO\_SHUTDOWN qualifier.

Determine the appropriate number of minutes for your configuration by weighing a smoother transition against completing a maximum number of jobs before shutdown. The larger the value, the smoother the transition will be. The smaller the value, the more jobs will execute on the node.

#### **/INVOKE\_SYSHUTDOWN (default)**

#### **/NOINVOKE\_SYSHUTDOWN**

Invokes a site-specific shutdown procedure.

## **SYSMAN SHUTDOWN NODE**

### **/MINUTES\_TO\_SHUTDOWN=number**

The number of minutes until shutdown occurs. If the system logical name SHUTDOWN\$MINIMUM\_MINUTES is defined, its integer value is the minimum value that you can enter. Therefore, if the logical name is defined as 10, you must specify at least 10 minutes to final shutdown or an error message displays. If the logical name is not defined, and you do not enter a value, 0 minutes is the default.

### **/POWER\_OFF**

Specifies that the system is to power off after shutdown is complete.

### **/REASON=text**

The reason for the shutdown (one line).

### **/REBOOT\_CHECK**

#### **/NOREBOOT\_CHECK (default)**

Checks for basic operating system files and notifies you if any are missing. Be sure to replace missing files before rebooting.

### **/REBOOT\_TIME=time**

The time when you expect to reboot the system such as IMMEDIATELY, IN 10 MINUTES, 2 P.M., or 14:00:00. Shutdown displays this time in a shutdown message to users.

### **/REMOVE\_NODE**

#### **/NOREMOVE\_NODE (default)**

Removes a node from the active cluster quorum. Use this qualifier when you do not expect the shut-down node to rejoin the cluster for an extended period.

When you use the /REMOVE\_NODE qualifier, active quorum in the remainder of the cluster is adjusted downward to reflect the fact that the removed node's votes no longer contribute to the quorum value. The shutdown procedure readjusts the quorum by issuing the SET CLUSTER/EXPECTED\_VOTES command.

You can reset options by using the following command:

```
SYSMAN> STARTUP SET OPTIONS/NOVERIFY/NOCHECKPOINTING
```

For more information about cluster management, see *HP OpenVMS Cluster Systems*.

### **/SAVE\_FEEDBACK**

#### **/NOSAVE\_FEEDBACK (default)**

Records feedback data collected from the system since it was last booted and creates a new version of the AUTOGEN feedback data file, which you can use the next time you run AUTOGEN.

### **/SPIN\_DOWN\_DISKS**

#### **/NOSPIN\_DOWN\_DISKS (default)**

Spins down disks. You cannot spin down the system disk.

## Description

Because SYSMAN enables you to define the target environment, you can perform a shutdown on your local node, your own cluster, or a subset of nodes on your cluster. If you are shutting down a local node, SYSMAN does not require you to remain logged in to the system during the shutdown, as long as you set the environment to the local node. See the SHUTDOWN NODE command examples and the SET ENVIRONMENT command for more information.

In shutting down the system, the shutdown procedure:

1. At decreasing time intervals, broadcasts a message to users to log out.
2. Defines the system logical SHUTDOWN\$TIME to reflect the value entered with the /MINUTES\_TO\_SHUTDOWN qualifier. For example, if you entered /MINUTES\_TO\_SHUTDOWN=10 at 12:00, the shutdown time would be 12:10.

To see if a shutdown is in progress or determine the actual time for shutdown, use the command SHOW LOGICAL SHUTDOWN\$TIME.

3. At six minutes or less before shutdown, disables all nonoperator logins. If DECnet is running, it is shut down.
4. At one minute before shutdown, stops batch and device queues and the system job queue manager.
5. At zero minutes before shutdown, invokes the site-specific command procedure SYS\$MANAGER:SHUTDWN.COM.
6. Stops all user processes; however, system processes continue. Ancillary control processes (ACPs) may delete themselves when their mounted volumes are finally dismounted.
7. Stops the secondary processor on dual-processor systems.
8. Removes all installed images.
9. Dismounts volumes and spins down disks, if you requested it. Does not spin down the system disk and the quorum disk, if a quorum disk is present.
10. Closes the operator's log file.
11. Invokes SYS\$SYSTEM:OPCRASH to shut down the system.
12. Displays the following message if you did not request an automatic reboot:

```
SYSTEM SHUTDOWN COMPLETE - USE CONSOLE TO HALT SYSTEM
```

If you requested an automatic reboot, the system reboots, provided the necessary controls are set.

## Examples

1. 

```
SYSMAN> SET ENVIRONMENT/CLUSTER
SYSMAN> SHUTDOWN NODE/MINUTES TO SHUTDOWN=15/REBOOT TIME="later"-
_SYSMAN> /REASON="SOFTWARE UPGRĀDE"/REBOOT_CHECK/CLUSTER_SHUTDOWN
```

The first command in this example ensures that all nodes in the cluster will shut down. The second command requests a shutdown for the entire cluster and a reboot check for any missing operating system files. The following messages are displayed to users on the cluster:

## **SYSMAN SHUTDOWN NODE**

```
SHUTDOWN message on NODE21, from user SYSTEM at NODE21$0PA0: 12:00:00:20  
NODE21 will shut down in 15 minutes; back up later. Please log off NODE21.  
SOFTWARE UPGRADE
```

```
SHUTDOWN message on NODE22, from user SYSTEM at NODE22$0PA0: 12:00:00:22  
NODE22 will shut down in 15 minutes; back up later. Please log off NODE22.  
SOFTWARE UPGRADE
```

```
SHUTDOWN message on NODE23, from user SYSTEM at NODE23$0PA0: 12:00:00:24  
NODE23 will shut down in 15 minutes; back up later. Please log off NODE23.  
SOFTWARE UPGRADE
```

2. SYSMAN> SET ENVIRONMENT/NODE=0  
Password:  
SYSMAN> SHUTDOWN NODE/MINUTES=120  
%SYSMAN-I-SHUTDOWN, SHUTDOWN request sent to node  
SYSMAN> EXIT  
\$ LOGOUT

This example shuts down the local node in 2 hours. As long as you set the environment to the local node, a subprocess of the SMISERVER system detached process runs shutdown, and remaining logged into the system during the shutdown is not necessary. If you do not set the environment to the local node, the shutdown runs via a subprocess of the current process, requiring that you remain logged in during the shutdown cycle.

---

## **SPAWN**

Creates a subprocess of the current process. The context of the subprocess is copied from the current process. You can use the SPAWN command to leave SYSMAN temporarily, perform other tasks (such as displaying a directory listing or printing a file), and return to SYSMAN.

Note that SPAWN performs actions on the local node only. If you want to execute DCL commands or command procedures throughout your environment, use the DO command.

Requires TMPMBX or PRMMBX user privilege. The SPAWN command does not manage terminal characteristics. You cannot use the SPAWN and ATTACH commands if your terminal has an associated mailbox.

### **Format**

SPAWN [command-string]

### **Parameter**

#### **command-string**

Specifies a command string of fewer than 132 characters that you want executed in the context of the created subprocess. When the command completes execution, the subprocess terminates and control returns to the parent process. If you specify both a command string and the /INPUT qualifier, the command string executes before additional commands are obtained from the /INPUT qualifier.

### **Qualifiers**

#### **/INPUT=filespec**

Specifies an input file containing one or more DCL command strings that you want executed by the spawned subprocess. If you specify a command string along with an input file, the command string gets processed before the commands in the input file. When processing is complete, the subprocess terminates.

#### **/LOGICAL\_NAMES (default)**

#### **/NOLOGICAL\_NAMES**

Specifies that the logical names of the parent process are copied to the subprocess. When you do not want the subprocess to use the logical names of the parent process, enter the /NOLOGICAL\_NAMES qualifier.

#### **/OUTPUT=filespec**

Identifies the output file to which the results of the operation are written. Specify an output other than SYS\$OUTPUT whenever you use the /NOWAIT qualifier. This prevents output from being displayed while you are specifying new commands. If you omit the /OUTPUT qualifier, output gets written to the current SYS\$OUTPUT device.

#### **/PROCESS=subprocess-name**

Specifies the name of the subprocess that you want to create. The default subprocess name is in the format USERNAME\_n.

## **SYSMAN SPAWN**

### **/SYMBOLS (default)**

#### **/NOSYMBOLS**

Determines whether the system passes DCL global and local symbols to the subprocess.

### **/WAIT (default)**

#### **/NOWAIT**

Controls whether the system waits until the subprocess completes before you can specify more commands. The **/NOWAIT** qualifier enables you to specify new commands while the specified subprocess is running. If you specify the **/NOWAIT** qualifier, use the **/OUTPUT** qualifier to direct the output to a file instead of displaying it on the screen. Doing this prevents your terminal from being used by more than one process simultaneously.

## **Description**

The **SPAWN** command creates a subprocess of your current process with the following attributes copied from the parent process:

- All symbols except **\$RESTART**, **\$SEVERITY**, and **\$STATUS**
- Key definitions
- The current keypad state
- The current prompt string
- All process logical names and logical name tables except those explicitly marked **CONFINE** or those created in executive or kernel mode
- Default disk and directory
- Current **SET MESSAGE** settings
- Current process privileges
- Control and verification states

Note that some attributes, such as the process's current command tables, are not copied.

When the subprocess is created, the process-permanent open files and any image or procedure context are not copied from the parent process. The subprocess is set to command level 0 (DCL level with the current prompt).

If you do not specify the **/PROCESS** qualifier, the name of this subprocess is composed of the same base name as the parent process and a unique number. For example, if the parent process name is **SMITH**, the subprocess name can be **SMITH\_1**, **SMITH\_2**, and so on.

The **LOGIN.COM** file of the parent process is not executed for the subprocess because the context is copied separately, allowing quicker initialization of the subprocess. When the **/WAIT** qualifier is in effect, the parent process remains in hibernation until the subprocess terminates or returns control to the parent by way of the **ATTACH** command.

More than one process simultaneously attempts to use the same input or output stream when several processes share that stream and you perform one of the following actions:

- Terminate a subprocess to which you are not currently attached.

- Terminate a process that is not spawned from the process to which you are currently attached.

Use the LOGOUT command to terminate the subprocess and return to the parent process. You can also use the ATTACH command (see ATTACH) to transfer control of the terminal to another process in the subprocess tree, including the parent process. (The SHOW PROCESS/SUBPROCESSES command displays the processes in the subprocess tree and points to the current process.)

---

**Note**

---

Because a tree of subprocesses can be established using the SPAWN command, you must be careful when terminating any process in the tree. When a process is terminated, all subprocesses below that point in the tree are automatically terminated.

---

Qualifiers used with the SPAWN command must directly follow the command verb. The command string parameter begins after the last qualifier and continues to the end of the command line.

## Examples

1. SYSMAN> SPAWN DIR SYS\$MANAGER:SITE\*.\*

```
Directory CLU$COMMON:[SYSMGR]
SITE$STARTUP.COM;5
Total of 1 file.
SYSMAN>
```

This command enables you to enter the DIRECTORY command in DCL to see if a site-specific startup file is in the directory. After the DIRECTORY command executes, control returns to the parent process.

2. SYSMAN> SPAWN  
\$ EDIT SITE\$STARTUP.COM

```
.
.
.
$ LOGOUT
Process SYSTEM_1 logged out at 28-JUN-2002 10:05:17.24
SYSMAN>
```

This example shows how you can use the SPAWN command to leave SYSMAN and edit a file. The LOGOUT command returns you to SYSMAN.

3. SYSMAN> SPAWN /NOLOGICAL\_NAMES SET HOST  
\_Node: NODE21

```
.
.
.
$ LOGOUT
%REM-S-END, control returned to node _NODE22::
SPAWN>
```

## **SYSMAN SPAWN**

This example shows how you can use the SPAWN command to create a subprocess in which you can use the SET HOST command. When you want to leave NODE21, enter the LOGOUT command. The /NOLOGICAL\_NAMES qualifier prevents the logical names of the parent process from being copied to the subprocess.



---

## STARTUP ADD

Adds a component to the startup database.

Requires read (R) and write (W) access to the startup database.

### Format

STARTUP ADD FILE filespec

### Parameters

#### **FILE**

Adds a component to the startup database. SYSMAN modifies STARTUP\$STARTUP\_LAYERED by default.

#### **filespec**

Specifies which file to add to the startup database. Each component of the startup database must have a file type of .COM or .EXE and reside in SYS\$STARTUP.

### Qualifiers

#### **/CONFIRM**

#### **/NOCONFIRM (default)**

Controls whether SYSMAN displays the file specification of each file before adding it to the startup database and requests you to confirm the addition. If you specify /CONFIRM, you must respond to the prompt with a Y (Yes) or a T (True) and press Return before the file is added. If you enter anything else, such as N or No, the requested file is not added.

#### **/LOG**

#### **/NOLOG (default)**

Controls whether the STARTUP ADD command displays the file specification of each file after it has been added.

#### **/MODE=mode**

Specifies the mode of execution for the file. Valid modes include DIRECT, SPAWN, BATCH, or ANY, as described in the *HP OpenVMS System Manager's Manual*.

#### **/NODE=(node1,node2,...,noden)**

Names the nodes within the cluster that run the file during startup. By default, a startup file executes on all nodes in the cluster.

#### **/PARAMETER=(P1:arg1,P2:arg2,...,P8:arg8)**

Specifies the parameters that are to be passed to the file during startup. Parameters that are omitted receive the default parameters defined by the system parameter STARTUP\_Pn. If STARTUP\_Pn is blank, "FULL" is used as parameter 1 (P1) and is passed by STARTUP.COM to each startup component file. If you want a blank P1 parameter given to a specific component file, use the command:

```
SYSMAN> STARTUP MODIFY FILE component.com/PARAM=P1:""
```

#### **/PHASE=phase-name**

Indicates the phase within system startup when the file is to be executed. Valid phases include LPBEGIN, LPMAIN, LPBETA, and END. LPMAIN is the default.

## **SYSMAN STARTUP ADD**

### **Description**

The `STARTUP ADD` command adds a component to the startup database. Startup components are the command procedures or executable files that perform actual startup work. Files from the startup database are used to start the operating system, site-specific programs, and layered products. `STARTUP$STARTUP_VMS` and `STARTUP$STARTUP_LAYERED` list the components of the startup database.

Because an OpenVMS Cluster typically shares one copy of the startup database, the SYSMAN environment can be defined as clustered or as a single node within the cluster.

### **Example**

```
SYSMAN> STARTUP ADD FILE /MODE=DIRECT /PHASE=LPMAIN -  
_SYSMAN> DECSET$ENVMGR_STARTUP.COM
```

This command adds a record to the startup database that starts the DECSET environment manager software.

---

## **STARTUP DISABLE**

Prevents a file in the startup database from executing.

Requires read (R) and write (W) access to the startup database.

### **Format**

STARTUP DISABLE FILE filespec

### **Parameters**

#### **FILE**

Disables a component of the startup database. SYSMAN modifies STARTUP\$STARTUP\_LAYERED by default.

#### **filespec**

Specifies the name of a component in the startup database. The startup file must reside in SYS\$STARTUP and have a file type of .COM or .EXE. The asterisk (\*) and percent (%) wildcard characters are permitted.

### **Qualifiers**

#### **/CONFIRM**

#### **/NOCONFIRM (default)**

Controls whether the STARTUP DISABLE command displays the file specification of each file before disabling it in the startup database and requests you to confirm that the file be disabled. If you specify /CONFIRM, you must respond to the prompt with a Y (Yes) or a T (True) and press Return before the file is disabled. If you enter anything else, such as N or No, the requested file is not disabled.

#### **/LOG**

#### **/NOLOG (default)**

Controls whether the STARTUP DISABLE command displays the file specification of each file after it has been disabled.

#### **/NODE=(node1,node2,...,noden)**

Identifies nodes within the cluster that do not run the file during startup. By default, the startup file is disabled on all nodes in the cluster.

#### **/PHASE=phase-name**

Indicates the phase of system startup in which the specified file normally executes. Valid phases include LPBEGIN, LPMAIN, LPBETA, and END. LPMAIN is the default.

### **Description**

The STARTUP DISABLE command prevents a file in the startup database from executing. The command edits a record in the startup database, temporarily disabling the file.

## **SYSMAN STARTUP DISABLE**

### **Example**

```
SYSMAN> STARTUP DISABLE FILE /NODE=NODE21 DECSET$ENVMGR_STARTUP.COM
```

This command modifies the startup database so that the DECset environment manager will not be installed on NODE21.

---

## **STARTUP ENABLE**

Enables a previously disabled file in the startup database to execute during system startup.

Requires read (R) and write (W) access to the startup database.

### **Format**

STARTUP ENABLE FILE filespec

### **Parameters**

#### **FILE**

Enables a component of the startup database. SYSMAN modifies STARTUP\$STARTUP\_LAYERED by default.

#### **filespec**

Specifies the name of the startup file that you are enabling. Wildcard characters are accepted.

### **Qualifiers**

#### **/CONFIRM**

#### **/NOCONFIRM (default)**

Controls whether the STARTUP ENABLE command displays the file specification of each file before enabling it in the startup database and requests you to confirm that the file be enabled. If you specify /CONFIRM, you must respond to the prompt with a Y (Yes) or a T (True) and press Return before the file is enabled. If you enter anything else, such as N or No, the requested file is not enabled.

#### **/LOG**

#### **/NOLOG (default)**

Controls whether the STARTUP ENABLE command displays the file specification of each file after it has been enabled.

#### **/NODE=(node1,node2,...,noden)**

Names nodes within the cluster where the file will be enabled. By default, the startup file is enabled on all nodes.

#### **/PHASE=phase-name**

Indicates the phase within system startup when the specified file is to be enabled. Valid phases include LPBEGIN, LPMAIN, LPBETA, and END. LPMAIN is the default.

### **Description**

The STARTUP ENABLE command permits a file that was previously disabled to execute during system startup.

### **Example**

```
SYSMAN> STARTUP ENABLE FILE /NODE=NODE22 DECSET$ENVMGR_STARTUP.COM
```

This command modifies the startup database. NODE22 will have the DECSET environment manager installed at startup.

## **SYSMAN STARTUP MODIFY**

---

### **STARTUP MODIFY**

Changes information associated with a startup file in the startup database.  
Requires read (R) and write (W) access to the startup database.

#### **Format**

STARTUP MODIFY FILE filespec

#### **Parameters**

##### **FILE**

Modifies a record in the startup database. SYSMAN modifies STARTUP\$STARTUP\_LAYERED by default.

##### **filespec**

Selects a startup file for modification. Wildcard characters are accepted.

#### **Qualifiers**

##### **/CONFIRM**

##### **/NOCONFIRM (default)**

Controls whether the STARTUP MODIFY command displays the file specification of each file before modifying its startup characteristics in the startup data file and requests you to confirm that the file characteristics be modified. If you specify /CONFIRM, you must respond to the prompt with a Y (Yes) or a T (True) and press Return before the file is modified. If you enter anything else, such as N or No, the requested file is not modified.

##### **/LOG**

##### **NOLOG (default)**

Controls whether the STARTUP MODIFY command displays the file specification of each file after its startup characteristics have been modified.

##### **/MODE=mode**

Changes the mode of execution for a startup file. Valid modes include DIRECT, SPAWN, BATCH, or ANY, as described in the *HP OpenVMS System Manager's Manual*.

##### **/NAME=filespec**

Changes the name of the startup file. The file must reside in SYS\$STARTUP.

##### **/PARAMETER=(P1:arg1,P2:arg2,...,P8:arg8)**

Changes the parameters that are to be passed to the file during startup. Parameters that are omitted receive the default parameters defined by the system parameter STARTUP\_Pn. If STARTUP\_Pn is blank, "FULL" is used as parameter 1 (P1) and is passed by STARTUP.COM to each startup component file. If you want a blank P1 parameter given to a specific component file, use the command:

```
SYSMAN> STARTUP MODIFY FILE component.com/PARAM=P1:""
```

##### **/PHASE=phase-name**

Selects startup files for modification based on the phase in which they run. Valid phases include LPBEGIN, LPMAIN, LPBETA, and END. LPMAIN is the default.

## **Description**

The `STARTUP MODIFY` command edits startup information associated with components in the startup database. For example, the command can rename a file or change the parameters that are passed to a file during startup. You can select a group of files for modification based on the phase in which they run.

## **Example**

```
SYSMAN> STARTUP MODIFY FILE DECSET$ENVMGR STARTUP.COM -  
_SYSMAN> /PARAM=(P3:TRUE,P4:FALSE) /CONFIRM
```

This command changes two startup parameters for the command procedure `DECSET$ENVMGR_STARTUP.COM`.

# **SYSMAN STARTUP REMOVE**

---

## **STARTUP REMOVE**

Removes a record in the startup database, so the specified startup file no longer executes during system startup.

Requires read (R) and write (W) access to the startup database.

### **Format**

STARTUP REMOVE FILE filespec

### **Parameters**

#### **FILE**

Removes a component from the startup database. SYSMAN modifies STARTUP\$STARTUP\_LAYERED by default.

#### **filespec**

Specifies the name of the file to remove from the startup database. Wildcard characters are accepted.

### **Qualifiers**

#### **/CONFIRM**

#### **/NOCONFIRM (default)**

Controls whether the STARTUP REMOVE command displays the file specification of each file before deleting its record in the startup database and requests you to confirm that the file be deleted. If you specify /CONFIRM, you must respond to the prompt with a Y (Yes) or a T (True) and press Return before the file is removed. If you enter anything else, such as N or No, the requested file is not removed.

#### **/LOG**

#### **/NOLOG (default)**

Controls whether SYSMAN displays the file specification of each file after it has been removed.

#### **/PHASE=phase-name**

Indicates the phase of system startup from which the file will be removed. Valid phases include LPBEGIN, LPMAIN, LPBETA, and END.

### **Example**

```
SYSMAN> STARTUP REMOVE FILE DECSET$ENVMGR_STARTUP.COM /LOG
```

This command takes the file DECSET\$ENVMGR\_STARTUP.COM out of the startup database.



---

## STARTUP SET DATABASE

Establishes the current startup database.

### Format

STARTUP SET DATABASE database

### Parameter

#### database

Specifies the name of the target database, which is STARTUP\$STARTUP\_LAYERED by default. The second database, STARTUP\$STARTUP\_VMS, is available for viewing; however, HP recommends that you do not modify it.

### Qualifiers

None.

### Example

```
SYSMAN> STARTUP SET DATABASE STARTUP$STARTUP_LAYERED
%SYSMAN-I-NEWCOMPFIL, current component file is now STARTUP$STARTUP_LAYERED
SYSMAN> STARTUP SHOW FILE
%SYSMAN-I-COMPFIL, contents of component database on node LUCERN
Phase   Mode   File
-----
LPBEGIN DIRECT VMS$LPBEGIN_070_STARTUP.COM
LPMAIN  DIRECT FOR$LPMAIN_070_STARTUP.COM
```

The commands in this example establish the layered products database as the default, so it can be displayed.

# SYSMAN STARTUP SET OPTIONS

---

## STARTUP SET OPTIONS

Controls logging and display of information for one or more nodes in a cluster during startup.

Requires READ (R) and WRITE (W) access to the current system parameter file on disk: SYS\$SYSTEM:ALPHAVMSSYS.PAR (for Alpha), and SYS\$SYSTEM:IA64VMSSYS.PAR (for Integrity servers).

### Format

STARTUP SET OPTIONS

### Parameters

None.

### Qualifiers

#### **/CHECKPOINTING /NOCHECKPOINTING**

Displays informational messages describing the time and status of each startup phase and component procedure.

The value of the system parameter STARTUP\_P2 that corresponds to /OUTPUT=CHECKPOINTING is "C".

#### **/OUTPUT=FILE,CONSOLE**

Sends output generated by using the /VERIFY qualifier to a file or to the system console. If you choose the FILE option, it creates SYS\$SPECIFIC:[SYSEXEC]STARTUP.LOG.

The value of the system parameter STARTUP\_P2 that corresponds to /OUTPUT=FILE is "D".

#### **/VERIFY=FULL,PARTIAL /NOVERIFY**

Displays startup procedures as they execute. This qualifier defines the system parameter STARTUP\_P2 to have the appropriate value based on the options you choose. (/VERIFY with no value following it is the equivalent of /VERIFY=full.)

/VERIFY options are in the following table:

| Value   | Description  |
|---------|--|
| FULL    | Displays every line of DCL executed by startup component procedures and by STARTUP.COM.<br>The value of the system parameter STARTUP_P2 that corresponds to this option is "V".                                |
| PARTIAL | Displays every line of DCL executed by startup component procedures, but does not display DCL executed by STARTUP.COM.<br>The value of the system parameter STARTUP_P2 that corresponds to this option is "P". |

---

**Caution**

---

All STARTUP\_P2 parameter values modified by the SYSMAN STARTUP OPTIONS will be overridden by the AUTOGEN command procedure. To preserve any parameter modifications made with SYSMAN, edit the SYS\$SYSTEM:MODPARAMS.DAT file, as explained in the *HP OpenVMS System Manager's Manual*.

---

## Description

The STARTUP SET OPTIONS command enables you to control logging and checkpointing during startup. You can control the amount of information logged (full or partial) and where it is displayed (file or console). You can also choose checkpointing, which displays informational messages about the time and status of each phase during startup.

The default options are /NOCHECKPOINTING, /OUTPUT=CONSOLE, and /NOVERIFY.

Because SYSMAN enables you to define the target environment, you can perform startup logging on your local node, your own cluster, and a subset of nodes on your cluster. See the SET ENVIRONMENT command for more information.

## Example

```
SYSMAN> STARTUP SET OPTIONS/VERIFY=FULL/OUTPUT=FILE/CHECKPOINTING
```

This example requests startup logging with full verification, output to SYS\$SPECIFIC:[SYSEXE]STARTUP.LOG, and checkpointing. The corresponding value for system parameter STARTUP\_P2 is "VDC".

# SYSMAN STARTUP SHOW

---

## STARTUP SHOW

Displays the name of the current startup database or its components as well as the startup logging options selected with the STARTUP SET OPTIONS command.

### Format

```
STARTUP SHOW DATABASE
                FILE
                OPTIONS
```

### Parameters

#### **DATABASE**

Displays the name of the current startup database. The two startup databases are STARTUP\$STARTUP\_LAYERED and STARTUP\$STARTUP\_VMS. HP recommends that you do not modify the STARTUP\$STARTUP\_VMS database.

#### **FILE**

Displays the contents of the current startup database. The display includes the file name, phase, and mode of execution for each component in the database.

#### **OPTIONS**

Displays the options selected when using the STARTUP SET OPTIONS command.

### Qualifiers

#### **/FULL**

Displays full information about each component in the database. In addition to the phase, file name, and mode of execution for each startup component, SYSMAN displays the nodes on which the file executes and the parameters passed to the file. This qualifier is relevant with the FILE parameter.

#### **/NODE**

Displays the nodes within the cluster on which the file executes. By default, a startup file executes on all nodes in an environment. This qualifier is relevant with the FILE parameter.

#### **/OUTPUT=filespec**

Redirects command output from SYS\$OUTPUT to the file named with the qualifier. Without a filespec, SYSMAN writes the output to SYSMAN.LIS in the current directory.

#### **/PARAMETERS**

Lists the parameters with which the startup file executes. Parameters that are not specified receive the defaults defined by the system parameter STARTUP\_Pn. If STARTUP\_Pn is blank, "FULL" is used as parameter 1 (P1) and is passed by STARTUP.COM to each startup component file. If you want a blank P1 parameter given to a specific component file, see the /PARAMETER qualifier under STARTUP MODIFY command for instructions.

**/PHASE=phase-name**

Displays components that execute in a specific phase of system startup. Valid phases include LPBEGIN, LPMAIN, LPBETA, and END. LPMAIN is the default. This qualifier is relevant with the FILE parameter.

**Example**

```
SYSMAN> STARTUP SET DATABASE STARTUP$STARTUP_VMS
SYSMAN> STARTUP SHOW FILE
%SYSMAN-I-COMPFIL, contents of component database on node LUCERN
Phase      Mode      File
-----
BASEENVIRON  DIRECT  VMS$BASEENVIRON_050_LIB.COM
BASEENVIRON  CALLED  VMS$BASEENVIRON_050_SMISERVER.COM
BASEENVIRON  DIRECT  VMS$BASEENVIRON_050_VMS.COM
.
.
.
```

The commands in this example display the contents of the startup database.

## **SYSMAN SYS\_LOADABLE ADD**

---

### **SYS\_LOADABLE ADD**

Adds an entry in the system images file SYS\$UPDATE:VMS\$SYSTEM\_IMAGES.IDX.

---

#### **Caution**

---

The SYS\_LOADABLE ADD command is not intended for general use. Only advanced system programmers should use this command.

---

### **Format**

SYS\_LOADABLE ADD product image

### **Parameters**

#### **product**

A 1- to 8-character product mnemonic that uniquely identifies a loadable image. For user-written images, this should typically contain the string `_LOCAL_`.

#### **image**

The file name of the system loadable image you want to add. A file name is the only value you can specify for this parameter. Do not specify a device, directory, file type, or wildcard characters.

### **Qualifiers**

#### **/LOAD\_STEP**

Indicates the step of the booting process at which you want the image loaded. Valid load steps are INIT (which causes the system initialization code to load the image), and SYSINIT (which causes the SYSINIT process to load the image).

If you do not specify a value for the `/LOAD_STEP` qualifier, it defaults to SYSINIT.

#### **/LOG**

#### **/NOLOG (default)**

Controls whether the SYS\_LOADABLE ADD command displays a notification after the entry has been added.

#### **/MESSAGE**

Enables you to specify the text of a message that is displayed when the appropriate condition is met (see the `/SEVERITY` qualifier). The default message is "system image load failed".

#### **/SEVERITY**

Determines how the image load status will affect console output and booting progress. You can specify the following values for this qualifier:

| <b>Value</b> | <b>Description</b>  |
|--------------|---|
| FATAL        | If an error occurs loading the image, display the error message and BUGCHECK information. |
| INFORMATION  | Display the message and continue processing.  |
| SUCCESS      | Continue even if loading the image produces an error. Does not display the message.       |
| WARNING      | If an error occurs loading the image, display the error message and continue processing.  |

If you do not specify a value for the /SEVERITY qualifier, it defaults to WARNING.

### **Description**

The SYS\_LOADABLE ADD command adds an entry to the system images file SYS\$UPDATE:VMS\$SYSTEM\_IMAGES.IDX. You can then process this file using the command procedure SYS\$UPDATE:VMS\$SYSTEM\_IMAGES.COM. Processing the file with VMS\$SYSTEM\_IMAGES.COM generates a new system images data file that the system uses when it boots.

If the file SYS\$UPDATE:VMS\$SYSTEM\_IMAGES.IDX does not exist, the SYS\_LOADABLE ADD command creates a new one.

# SYSMAN

## SYS\_LOADABLE REMOVE

---

### SYS\_LOADABLE REMOVE

Removes an entry in the system images file SYS\$UPDATE:VMS\$SYSTEM\_IMAGES.IDX.

---

#### Caution

---

The SYS\_LOADABLE REMOVE command is not intended for general use. Only advanced system programmers should use this command.

---

### Format

```
SYS_LOADABLE REMOVE product
                        image
```

### Parameters

#### product

A 1- to 8-character product mnemonic that uniquely identifies a loadable image. For user-written images this should typically contain the string `_LOCAL_`.

#### image

The file name of the system loadable image you want to remove. A file name is the only value you can specify for this parameter. Do not specify a device, directory, file type, or wildcard characters.

### Qualifier

#### /LOG

#### /NOLOG (default)

Controls whether the SYS\_LOADABLE REMOVE command displays a notification after the entry has been removed.

### Description

The SYS\_LOADABLE REMOVE command removes an entry from the system images file SYS\$UPDATE:VMS\$SYSTEM\_IMAGES.IDX. You can then process this file using the command procedure SYS\$UPDATE:VMS\$SYSTEM\_IMAGES.COM. Processing the file with VMS\$SYSTEM\_IMAGES.COM generates a new system images data file that the system uses when it boots.

If the file SYS\$UPDATE:VMS\$SYSTEM\_IMAGES.IDX does not exist, the SYS\_LOADABLE REMOVE command creates a new, empty one.



## 9.4 RAD Example

The following example procedure shows how to use SYSMAN resource affinity domain (RAD) qualifiers and options.

1. Show that no reserved memory registry exists:

```
SYSMAN> reserved_memory list
%SYSMAN-I-NODERR, error returned from node PIPERI
-RMS-E-FNF, file not found
```

2. Add a reservation for a group global section and display the new reservation:

```
SYSMAN> reserved_memory add ak_sec/gr=4711 /size=16 /zero /page_tables
SYSMAN> reserved_memory list
```

```
%SYSMAN-I-OUTPUT, command execution on node PIPERI
Reservation Name      Group  RAD  Size (MB)  Pages  Attributes
AK_SEC                4711  ANY   16         2048  Allocated Zeroed
AK_SEC                4711             2          2  PageTables Allocated
```

3. Modify the reservation to have memory assigned from each of four RADs; display the result:

```
SYSMAN> reserved_memory modify ak_sec/gr=4711 /new_rad=0 /size=4
SYSMAN> reserved_memory extend ak_sec/gr=4711 /rad=1 /size=4
SYSMAN> reserved_memory extend ak_sec/gr=4711 /rad=2 /size=4
SYSMAN> reserved_memory extend ak_sec/gr=4711 /rad=3 /size=4
SYSMAN> reserved_memory list
```

```
%SYSMAN-I-OUTPUT, command execution on node PIPERI
Reservation Name      Group  RAD  Size (MB)  Pages  Attributes
AK_SEC                4711   0     4          512  Allocated Zeroed
AK_SEC                4711   1     4          512  Allocated Zeroed
AK_SEC                4711   2     4          512  Allocated Zeroed
AK_SEC                4711   3     4          512  Allocated Zeroed
AK_SEC                4711             2          2  PageTables Allocated
```

4. Modify the reservation to no longer zero allocated pages at boot time. Note that you can change properties such as /ZERO, /ALLOCATE, /PAGE\_TABLES only for the reservation as a whole, not for a specific RAD.

```
SYSMAN> reserved_memory modify ak_sec/gr=4711 /nozero
SYSMAN> reserved_memory list
```

```
%SYSMAN-I-OUTPUT, command execution on node PIPERI
Reservation Name      Group  RAD  Size (MB)  Pages  Attributes
AK_SEC                4711   0     4          512  Allocated
AK_SEC                4711   1     4          512  Allocated
AK_SEC                4711   2     4          512  Allocated
AK_SEC                4711   3     4          512  Allocated
AK_SEC                4711             2          2  PageTables Allocated
```

5. Modify the reservation to no longer request memory from specific RADs. Note that the overall size remains unchanged.

```
SYSMAN> reserved_memory modify ak_sec/gr=4711 /norad
SYSMAN> reserved_memory list
```

```
%SYSMAN-I-OUTPUT, command execution on node PIPERI
Reservation Name      Group  RAD  Size (MB)  Pages  Attributes
AK_SEC                4711  ANY   16         2048  Allocated
AK_SEC                4711             2          2  PageTables Allocated
```

6. Starting with a reservation allocated across multiple RADs, request that memory no longer be allocated at boot time. Note that this implies that memory is no longer allocated from specific RADs.

## System Management Utility

### 9.4 RAD Example

Reservation prior to change:

```
SYSMAN> reserved_memory list
```

```
%SYSMAN-I-OUTPUT, command execution on node PIPERI
Reservation Name  Group  RAD  Size (MB)  Pages  Attributes
AK_SEC           4711   0    4          512   Allocated
AK_SEC           4711   1    4          512   Allocated
AK_SEC           4711   2    4          512   Allocated
AK_SEC           4711   3    4          512   Allocated
AK_SEC           4711                   2   PageTables Allocated
```

Command to no longer allocate at boot time:

```
SYSMAN> reserved_memory modify ak_sec/gr=4711 /noalloc
```

New state of reservation:

```
SYSMAN> reserved_memory list
```

```
%SYSMAN-I-OUTPUT, command execution on node PIPERI
Reservation Name  Group  RAD  Size (MB)  Pages  Attributes
AK_SEC           4711   ANY  16         2048
AK_SEC           4711                   2   PageTables
```

7. To change the size of a reservation with an assigned RAD, or to change the reservation to use a different RAD, you must specify the current RAD.

Reservation prior to change:

```
SYSMAN> reserved_memory list
```

```
%SYSMAN-I-OUTPUT, command execution on node PIPERI
Reservation Name  Group  RAD  Size (MB)  Pages  Attributes
AK_SEC           4711   2    16         2048   Allocated
AK_SEC           4711                   2   PageTables Allocated
```

Attempt to change reservation size:

```
SYSMAN> reserved_memory mod ak_sec/gr=4711 /size=20
%SYSMAN-I-NODERR, error returned from node PIPERI
-SMI-E-RMRNOMATCH, no records matched search criteria
```

Correct command:

```
SYSMAN> reserved_memory mod ak_sec/gr=4711 /rad=2 /size=20
```

New state of reservation:

```
SYSMAN> reserved_memory list
```

```
%SYSMAN-I-OUTPUT, command execution on node PIPERI
Reservation Name  Group  RAD  Size (MB)  Pages  Attributes
AK_SEC           4711   2    20         2560   Allocated
AK_SEC           4711                   3   PageTables Allocated
```

---

## USB Configuration Manager (UCM)

### 10.1 UCM Description

The USB (Universal Serial Bus) Configuration Manager (UCM) utility allows you to connect a computer to a variety of devices using a single four-wire cable. More specifically, UCM does the following:

- Records events such as plugging or unplugging devices and errors that occur on a USB bus. This is the USB event-logging function of UCM.
- Maps physical devices to persistent device names (based on either serial number or bus location).
- Automatically configures and loads OpenVMS device drivers for known device types.
- Manages additions, deletions, and modifications to devices configured on the system.

#### Types of UCM Configuration

Beginning in OpenVMS Version 8.3, UCM automatically configures any new (non-permanent) device, loads the OpenVMS device driver for it, and makes the device permanent. This means that adding a new device to the system is as simple as plugging it in. This is **automatic configuration**.

However, you might decide to disable automatic recognition and configuration of new devices, or restrict the automatic configuration only to specific devices. You do this by first using a UCM SET AUTO command. You can then follow a number of procedures required for **manual configuration**.

#### Organization of This Chapter

Following explanations of USB and UCM concepts are sections that tell how to use UCM to configure devices automatically and manually. A section providing information about viewing events related to device configuration follows. The final section in the chapter details UCM commands and contains examples of these commands.

### 10.2 USB and UCM Concepts

OpenVMS tests and supports specific HP provided USB devices on HP Integrity servers.

In some cases, specific third-party devices are tested and supported by OpenVMS. For these devices, OpenVMS will respond to bug reports and fix defects in driver support for them. These devices are listed in appendices of the *HP OpenVMS Systems Management Utilities Reference Manual*.

## UCM

### 10.2 USB and UCM Concepts

The functionality of USB is such that in many cases broad categories of devices can be supported by a single generic device driver. OpenVMS does not attempt to prevent such unknown third-party devices from configuring and operating. However, HP cannot guarantee correct operation of such untested devices. If a problem occurs with such a device, it can be reported through support channels but there is no guarantee that the problem can be corrected or provide an ECO patch kit.

Should you require formal support for a third-party device a request for support can be made through your HP account team or HP distributor.

The following sections introduce and explain USB and UCM concepts.

#### 10.2.1 Introduction to USB

Universal Serial Bus (USB) is a communications architecture that enables a computer to interconnect a variety of devices using a single four-wire cable. The purpose of USB is to provide a user-friendly way to connect low- and medium-speed devices to host computers.

The USB connects USB devices to the USB host, which, in turn, connects with a host computer system. Each USB has only one host, labeled USB Host in Section 10.2.1. (A host, however, can have many USB controllers.)

Figure 10–1 USB Configuration

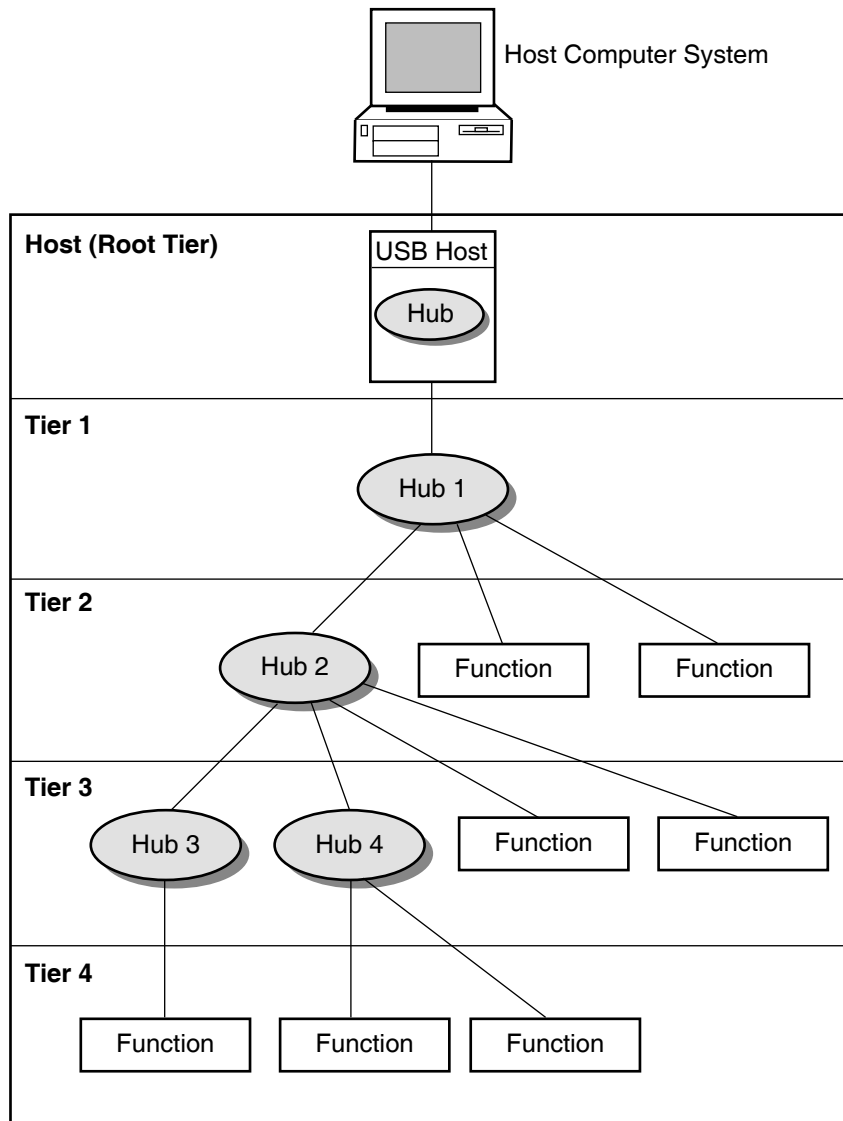

VM-1065A-AI

The USB host is integrated with a root hub, which provides one or more attachment points for devices. The USB physical interconnections from each hub form a star, with a hub at the center of each star.

Point-to-point wire connections link the USB host to a hub or a function, or a hub to another hub or function. Hubs and functions are USB devices that do the following:

- **Hubs** provide additional attachment points to the USB.
- **Functions** provide capabilities to the system, such as a mouse or a keyboard.

# UCM

## 10.2 USB and UCM Concepts

Figure 10–2 shows that up to six hubs can be chained to create a tiered configuration. The path of a device is determined by its location in the structure; for example, the path to the printer LPA0: in Figure 10–2 is 1.1.2.3.1.4. (Note, however, that the numbers printed on the physical hub might not match the numbers that UCM displays.)

Figure 10–2 Hub Tiers

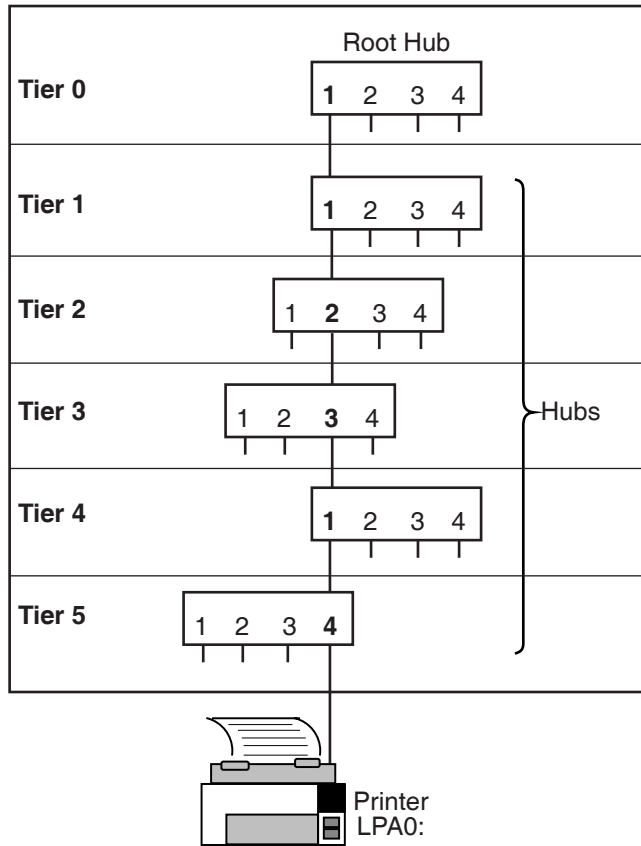

VM-1066A-AI

UCM works with the hub driver to configure USB-supported devices. The hub driver discovers devices and sends requests to the UCM server, which determines the action to be taken. By default, UCM configures and loads OpenVMS device drivers for the device and also logs activity. The UCM contains controls to inhibit or restrict device driver loading, and to allow manual intervention and modification of device driver loading and device naming.

### 10.2.2 UCM Concepts

UCM is made up of client and server layers. You, the user, interact with the client layer, and the client layer interacts with the server layer. It is the server layer that interacts with USB. Figure 10–3 shows the interaction of these layers.

**Figure 10–3 UCM Architecture**

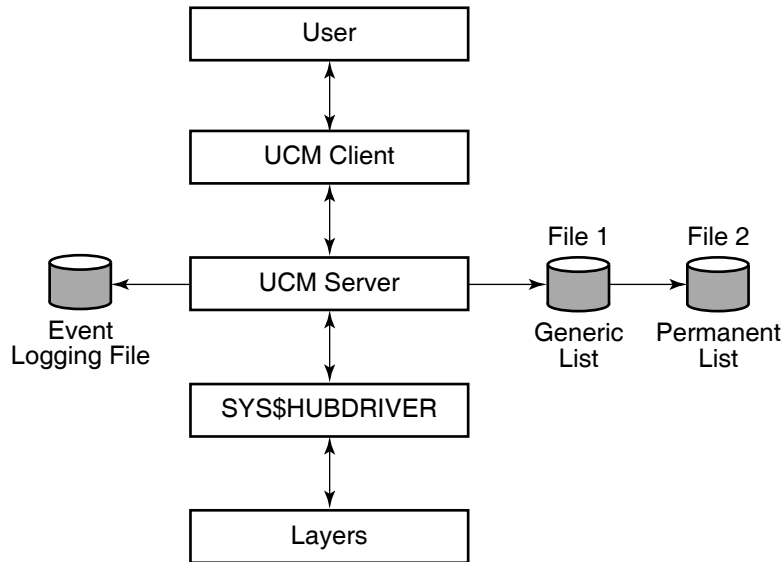

VM-1067A-AI

As the figure indicates, the UCM server maintains the event-logging file and the generic and permanent list files. These files are passed to the UCM server, which can display list files. (The types of lists that the UCM server uses are explained in UCM Lists.) The UCM server is in contact with the UCM driver, SYS\$HUBDRIVER, which maintains connections with other layers of the architecture.

### 10.2.3 The Discovery of Devices

The OpenVMS device names of USB devices are as follows:

| Device Name       | Description   |
|-------------------|---|
| AGAn <sup>1</sup> | Joystick  |
| DNA <sup>n</sup>  | Disk or other mass storage device (a pen drive, for example)  |
| KBD <sup>n</sup>  | Keyboard  |
| MOUn <sup>1</sup> | Mouse   |
| TXAn <sup>1</sup> | Modem   |
| TXB <sup>n</sup>  | Prolific driver   |
| TXC <sup>n</sup>  | Serial port (FTDI)  |
| TXD <sup>n</sup>  | Serial port (Edgeport/DIGI)                                   |
| LPAn <sup>1</sup> | Printer driver  |
| HID0              | Special-case driver that users cannot access                  |
| UCE0              | Special-case driver that works with Edgeport/DIGI             |
| UCM0              | Hub driver (one per system)                                   |
| UGAn <sup>1</sup> | USG generic driver that can be used to support custom devices |

<sup>1</sup>The value of *n* can be between 0 and 9999.

## UCM

### 10.2 USB and UCM Concepts

Unlike most backplane buses, the discovery of devices on a USB bus is an asynchronous process that can take an indeterminate amount of time to complete. The discovery of devices also requires an additional layer of discovery beyond that provided by the OpenVMS auto-configuration in SYSMAN. UCM supplies this secondary layer for the discovery and loading of device drivers. The result is that although USB devices connected to the system are discovered during a boot, the actual timing of the discovery depends on the number and configuration of devices, as well as other system events that can affect the timing.

If you write code or DCL procedures that expect to find or use USB devices, you must write this code to handle cases in which the devices might not have been discovered or configured yet, and also to handle the case of a device that has been unplugged (which will be offline). The code or DCL procedures, therefore, must retry or wait for the device to appear. It must also check to ensure that the device is connected (online).

In addition, the hub driver discovers devices plugged into the system after the boot at runtime; UCM configures these devices. Devices that are unplugged after being configured are set offline and made unusable until the device is reconnected to the system.

The UCM client provides a command-line interface for you to interact with the UCM server and to display information about devices and USB events that have occurred.

#### UCM Lists

The UCM server manages a number of in-memory lists that are used to configure USB devices:

- **Generic** list - Contains the device types known to UCM; is built from the system configuration database.
- **Tentative** list - Contains devices that the HUB driver has seen, but that UCM has not yet configured or made permanent. This list is usually empty.
- **Permanent** list - Contains devices that UCM has made persistent. Whenever this device is seen, it is configured and given the same OpenVMS device name.

The following table describes UCM lists in detail:

| List    | Description   |
|---------|---|
| Generic | <p>This list contains descriptions of devices that UCM supports. The generic list is part of the file-based device configuration information that is maintained on the system. (See Chapter 8 of the <i>HP OpenVMS System Manager's Manual</i>.)</p> <p>The installation process creates this list. A device that has no matching entry in the generic list is an unknown device type and cannot be configured.</p> |



| List      | Description  |
|-----------|--|
| Tentative | This is a list of devices that UCM has not yet configured. Usually, this list is empty because UCM automatically configures devices and makes them permanent. However, if automatic loading or automatic permanence is disabled, or if the device is excluded from loading with the SET AUTO command, the device is put on this list. The system manager can then display information about the device and manually add it as a permanent device. The tentative list, which is in memory, disappears when the server is restarted (when you enter the RELOAD command), or when the system reboots.   |
| Permanent | <p>This list contains devices that UCM always configures if the device is connected to the bus. The permanent list supplies a persistent name for a USB device; that is, the name is maintained across reboots and server restarts.</p> <p>Persistent names work somewhat differently on devices that have serial numbers from devices that do not have serial numbers:</p> <ul style="list-style-type: none"> <li>• On a device with a serial number, a persistent name always works.</li> <li>• On a device without a serial number, a name is persistent only if you attach the device in the same place on the hub each time you attach it.</li> </ul> |

---

A running system has only one permanent list, which UCM reads from SYS\$SYSTEM:USB\$UCM\_DEVICES.DAT. For most customers, this is the minimal file that OpenVMS provides in SYS\$COMMON:[SYSEXE].

---

**Caution**

---

Never delete USB\$UCM\_DEVICES.DAT. Deleting this file might result in the inability to use your USB attached devices.

---

## 10.3 Configuring Devices Automatically

UCM configuration can be either automatic or manual. This section explains how devices are configured automatically. Section 10.4 explains how to configure a device manually.

Automatic configuration of devices is simple: the device is configured by plugging it in. UCM automatically configures any new (non-permanent) device that is on the generic list, loads the OpenVMS device driver for it, and makes the device permanent.

The following list describes the actual steps that take place automatically, beginning at system startup:

1. OpenVMS starts the UCM server, which does the following:
  - a. Reads the settings for automatic loading and permanence as well as the exclude and include lists.
  - b. Reads the generic list of supported devices.
  - c. Reads the permanent list for descriptions of previously configured devices.
2. UCM initializes an empty tentative list.
3. UCM turns on the USB bus; a device on the bus announces itself.

## UCM

### 10.3 Configuring Devices Automatically

4. UCM checks for device data on the permanent list. If device data is on the permanent list, UCM loads it and makes it available.  
If device data is not on the list, UCM performs the next steps.
5. UCM checks for data on the generic list. If device data is on this list, UCM uses it to make an entry in the tentative list.
6. If automatic loading is enabled (the default), UCM attempts to load and connect the OpenVMS device driver for the device and creates an OpenVMS device instance.
7. If automatic permanence is enabled (the default), UCM moves the device from the tentative list to the permanent list, and updates the on-disk database of configured devices.
8. If the SET AUTO command has disabled automatic loading, the data stays on the tentative list until the user either adds the device to or deletes the device from the permanent list.

---

#### Notes

---

In configuring devices, keep in mind the following:

- Unplugging a device does not delete a tentative item.
- When automatic loading and permanence are disabled, a device added to the permanent list following UCM startup is not configured (that is, it is not available for use) until the device is subsequently disconnected and reconnected (unplugged and replugged).
- Any modification to the permanent list creates a new version of the file.

- 
9. Steps 3 through 8 repeat until all devices on all buses are processed.
  10. UCM then waits for a user request or until a device is plugged in or unplugged.

#### Log Files

UCM uses the following log file to record disconnections, connections, and errors:

```
SYS$MANAGER:USB$UCM_EVENTS.LOG
```

You do not need special permission to access the event log. However, you need OPER privilege to use the UCM command SET LOG/NEW command to create a new log file. (Section 10.7 contains a table of UCM commands and the privileges required to issue each command.)

### 10.4 Configuring Devices Manually

You might decide to disable automatic recognition and configuration of new devices, or to restrict the automatic configuration only to specific devices.

### 10.4.1 Disabling Automatic Configuration

If you do decide to disable all automatic configuration, enter the UCM SET AUTO/DISABLE command:

```
UCM> SET AUTO/DISABLE=(LOAD)
```

This command disables *all* automatic loading of *all* devices that are not in the permanent database.

This statement means that once a device has been configured and added to the permanent database, whenever it is connected to the system, UCM loads the driver for it and creates the device. Devices that are not in the permanent database are usually loaded automatically, and the device is created and placed in the permanent database.

When you turn off automatic loading with the SET AUTO/DISABLE=LOAD command, the device driver is not loaded, and the device is neither created nor placed on the permanent database. Instead, it is placed on the TENTATIVE list for manual user action.

#### Excluding One Type of Device from Loading

The other way to exclude a device from loading is to use the /EXCLUDE switch in the SET AUTO command. This is how a *specific* device is prevented from being loaded.

To disable the loading of a particular type of device, enter a command like the following:

```
UCM> SET AUTO/DISABLE=DNA
```

This command blocks DNA disks from automatic loading.

See the SET AUTO command for more information about its command qualifiers.

### 10.4.2 Creating an Entry in the Permanent List

This section describes the process of configuring a device that the UCM has not configured automatically because the device was excluded from automatic loading or automatic loading was disabled for all devices.

Before UCM can configure a USB device, the device must have a corresponding entry on the permanent list.

When you connect a USB device of a known type that has no entry on the permanent list, UCM uses information in the read-only generic list to create an entry in the tentative list. You must approve the entry before UCM will create an entry in the permanent list.

---

#### The Keyboard and Mouse

---

You do not, however, need to create an entry in the permanent list for a keyboard or a mouse because special permanent entries are pre-enabled for both of them. These permanent entries allow the system keyboard (KBD) and mouse (MOU) always to be connected and to be configured regardless of the setting for automatic loading.

These entries also allow any keyboard and any mouse connected anywhere on the USB bus to become KBD and MOU. This ensures that on a system with a graphics card, keyboard, and mouse, DECwindows always starts correctly.

---

## UCM

### 10.4 Configuring Devices Manually

To set up a device to be configured, add the device as an entry in the permanent list. After you do this, UCM recognizes the device each time you connect it.

In the following example, you connect a printer to the USB. The printer is a known device type; in other words, the printer has an entry in the generic list. However, it does not yet have an entry in the permanent list.

Follow these steps to configure the device:

1. Physically connect the printer.
2. Enter the UCM command to enter the UCM environment and to display a message about configured and unconfigured devices on your system:

```
$ UCM
UCM>
```

3. To display more information about the unconfigured device, enter the following command:

```
$ UCM
Universal Serial Bus Configuration Manager, Version V1.0
UCM> SHOW DEVICE /UNCONFIGURED

      DEVICE
                DEVICE_TYPE          TENTATIVE
                DEVICE_NAME_ROOT     LPA
                UNIT_NUMBER           0
                BUS_NUMBER            1
                PATH                   1.0.0.0.0.0
      END_DEVICE
UCM>
```

Note that the display on your screen might be somewhat different from the one you see here.

4. Next, approve the entry by entering the ADD command. For example:

```
UCM> ADD DEVICE LPA0:
UCM> EXIT
```

This command places the device information in the permanent list.

5. The last step before using the printer is to unplug the printer and reconnect it. This makes the device available for use. (If a device has no serial number, you must either plug it into the same port, or use the MODIFY command to indicate its new location.)

When you reconnect the printer, its serial number and vendor ID identify it as LPA0:. UCM configures the device and makes it available for use. (This step is not necessary if the UCM server is restarted or the system is rebooted.)

### 10.5 Viewing Configuration Events

The UCM event logger records events such as device connections and disconnections and certain types of errors. To see this information, use the UCM utility SHOW EVENTS command. You can also use qualifiers to limit the display of various types of events.

Events stored in the event log include the following:

- A device was configured or unconfigured.

- A known device was connected but not configured.
- An unknown device was connected.
- Text messages were sent by USB drivers.

The following sections explain how to display information about unknown devices and configuration failures.

### 10.5.1 Getting Information About Unknown Devices

UCM records unknown device connections in its event log. You can view this information by adding the /TYPE=UNKNOWN qualifier to the SHOW EVENT command.

The information in the following example includes the vendor ID, the product ID, and other optional device-supplied information. If an unknown device is connected to the USB, you might want to view only events showing the activity of unknown devices for today; for example:

```
UCM> SHOW EVENTS /TYPE=UNKNOWN /SINCE=TODAY
```

| Date  | Time        | Type    | Priority | Component          |
|---|-------------|---------|----------|--------------------|
| 22-AUG-2005   | 13:04:23.26 | UNKNOWN | NORMAL   | UCM UNKNOWN DEVICE |
| Message: VENDOR_ID = 1118<br>PRODUCT_ID = 8<br>RELEASE_NUMBER = 256<br>BUS_NUMBER = 1<br>PATH = 1.0.0.0.0<br>DEVICE_CLASS = 0<br>DEVICE_SUB_CLASS = 0<br>DEVICE_PROTOCOL = 0<br>NUMBER_OF_INTERFACES = 1<br>NUMBER_OF_CONFIGURATIONS = 1<br>MANUFACTURER_STRING = Microsoft<br>PRODUCT_STRING = Microsoft SideWinder Precision Pro (USB)<br>CONFIGURATION_NUMBER = 0. |             |         |          |                    |

```
UCM>
```

Note that the display on your screen might be somewhat different from the one you see here.

### 10.5.2 Getting Information about Configuration Failures

When UCM does not configure a device—because UCM cannot find an entry in the permanent list or because of a driver error—it stores this information in the event log. You can view such information using the SHOW EVENTS command and a qualifier that limits the display. The following is an example of plugging in a joystick with a missing device driver.

```
UCM> SHOW EVENTS /SINCE=YESTERDAY
```

| Date  | Time        | Type   | Priority | Component         |
|---|-------------|--------|----------|-------------------|
| 3-OCT-2005  | 09:06:11.20 | UCM    | NORMAL   | SYS\$AGDRIVER.EXE |
| Message: Tentative device AGA0 proposed... auto-loading driver. |             |        |          |                   |
| 3-OCT-2005  | 09:06:11.20 | UCM    | NORMAL   | SYS\$AGDRIVER.EXE |
| Message: Error from auto-load for AGA0 - status 0x18292.        |             |        |          |                   |
| 3-OCT-2005  | 09:06:11.20 | DRIVER | NORMAL   | HUBDRIVER         |
| Message: Configured device HID0 using driver SYS\$HIDDRIVER:    |             |        |          |                   |

## UCM

### 10.5 Viewing Configuration Events

```
UCM> exit
```

Note that the display on your screen might be somewhat different from the one you see here.

If no entry for the device is in the generic list, the log displays what is known about the device. If an error caused the failure, the error code is listed in the log.

You can use UCM commands to select the devices you want to configure and to view USB events such as connections, disconnections, and errors.

For a more detailed discussion of how you would add a device using UCM, see `SYS$COMMON:[SYSHLP.EXAMPLES.USB]UGDRIVER_PROGRAMMERS_GUIDE` in .PS, .PDF, AND HTML formats. This document tells how to use the USB generic driver and how to add USB generic entries.

### 10.6 UCM Usage Summary

The Universal Serial Bus (USB) Configuration Manager (UCM) utility allows you to connect a computer to a variety of USB devices using a single four-wire cable.

To invoke UCM, enter UCM at the DCL command prompt (\$):

```
$ UCM
```

```
UCM>
```

At the UCM> prompt, you can enter any UCM command described briefly in Section 10.7 and in more detail in the following sections.

Alternatively, you can enter UCM commands at the DCL prompt if you precede them with UCM. For example:

```
$ UCM RELOAD
```

```
$
```

To exit from UCM, enter the EXIT command at the UCM> prompt, or press Ctrl/Z.

### 10.7 UCM Commands

The following table summarizes UCM commands.

| Command       | Description   | Privilege Required |
|---------------|---|--------------------|
| ADD DEVICE    | Allows you to add a new device to the collection of known USB devices.                                    | SYSPRV             |
| DELETE DEVICE | Allows you to remove a device from the collection of known devices.                                       | SYSPRV             |
| EXIT          | Exits the UCM utility.  | None               |
| HELP          | Provides online help information for using the UCM commands.  | None               |
| MODIFY DEVICE | Modifies the unit number or flags of an entry in the permanent list. The changes take effect immediately. | SYSPRV             |
| RELOAD        | Reads the generic and permanent lists from disk.  | SYSPRV             |
| RESTART       | Restarts the configuration server.  | CMKRNL             |

## UCM 10.7 UCM Commands

| <b>Command</b> | <b>Description</b>   | <b>Privilege Required</b> |
|----------------|--|---------------------------|
| SET AUTO       | Enables (/ENABLE) or disables (DISABLE) auto-loading and permanence. Also allows setting both exclude and include lists. | SYSPRV                    |
| SET LOG/NEW    | Creates a new version of the event log file.   | OPER                      |
| SHOW AUTO      | Displays the settings of auto-load, auto-perm, and include and exclude lists.  | None                      |
| SHOW DEVICE    | Displays configured and unconfigured devices that are connected to the USB.  | None                      |
| SHOW EVENTS    | Displays events in the event log file.   | None                      |

## UCM ADD DEVICE

---

### ADD DEVICE

Allows you to add a new device to the collection of known USB devices.

Requires SYSPRV privilege.

#### Format

ADD DEVICE device-name:

#### Parameter

##### **device-name:**

The name of the device whose characteristics are to be added. The device name has the form *ddcu*

*where:*

*dd* is the device code—for example, LP. (The driver name corresponds to the device code; in this case, the driver name would be SYS\$LPDRIVER.)

*c* is the controller designation A through Z; unless UCM specifies a different letter, all USB devices are A.

*u* is the unit number (0 through 9999).

OpenVMS device names are made up of the two-character device code, followed by the controller designation, the unit number (which can be 1 to 4 characters long), and, finally, a colon (:).

#### Qualifiers

##### **/BUS\_NUMBER=number**

Specifies the USB bus number of the device. This parameter is required to identify a particular device on a system that has multiple USB buses. If you do not use this qualifier, the bus number defaults to zero.

The number can be from 0 through 25.

##### **/PATH=(n1[n2.n3.n4.n5.n6])**

Specifies the path to the device on the bus. The path is used to identify a device uniquely if the device does not have a serial number. The path specification is a series of six or fewer nonzero numbers,

*where:*

*n1* is the number of the port on the root hub (at tier 0).

*n2* through *n6* are port numbers for downstream hubs at tiers 1, 2, 3, 4, and 5. (If you do not specify trailing zeros, the UCM server supplies them.)

For example, /PATH=1.4.3 indicates that the device is plugged into port 3 of the second tier hub, which is plugged into port 4 of the first tier hub, which in turn is plugged into the root hub 1.

For a more detailed explanation of path specifications, see Figure 10–2 and the text that introduces the figure.



**/UNIT\_NUMBER=number**

Unit numbers can be between 0 and 9999. By default, UCM selects the next available unit number. This qualifier allows you to change the unit number to suit your needs.

**Example**

```
$ UCM
Universal Serial Bus Configuration Manager, Version V1.0
UCM> SHOW DEVICE /UNCONFIGURED
DEVICE
DEVICE_TYPE                TENTATIVE
DEVICE_NAME_ROOT           AGA
UNIT_NUMBER                0
BUS                        1
PATH                       1.0.0.0.0.0
END_DEVICE

UCM> ADD DEVICE AGA0:
UCM> SHOW DEVICE /PERMANENT /FULL AGA0:
DEVICE
DEVICE_TYPE                PERMANENT
DEVICE_NAME_ROOT           AGA
UNIT_NUMBER                0
DRIVER                     SYS$AGDRIVER.EXE
BUS NUMBER                 1
PATH                       1.0.0.0.0.0
HID USAGE DATA           65540
BEGIN_INTERFACE
HID USAGE DATA           65540
END_INTERFACE
END_DEVICE
UCM>
```

In this example, the first UCM command `SHOW DEVICE /UNCONFIGURED` indicates that the device has not yet been configured. It displays only the information that appears in the generic list: the device name root, the unit number, the bus, and the path.

After the `ADD DEVICE` command, the second `SHOW DEVICE` command, with the `/PERMANENT` and `/FULL` qualifiers, displays the information in the permanent list. The list includes the name of the driver assigned to the device, the bus number; and the Human Interface Device (HID) usage data number, which is used to configure devices in the HID interface class. Examples of HID devices are keyboards, mice, joysticks, and so on.

## UCM DELETE DEVICE

---

### DELETE DEVICE

Allows you to remove a device from the the permanent list.

Requires SYSPRV privilege.

### Format

```
DELETE DEVICE device-name:
```

### Parameters

#### **device-name:**

The name of the device whose characteristics are to be deleted. The device name has the form *ddcu*,

*where:*

*dd* is the device code—for example, LP. (The driver name corresponds to the device code; in this case, the driver name would be SYS\$LPDRIVER.)

*c* is the controller designation A through Z; unless UCM specifies a different letter, all USB devices are A.

*u* is the unit number (0 through 9999).

OpenVMS device names are made up of the two-character device code, followed by the controller designation, the unit number (which can be 1 to 4 characters long), and, finally, a colon (:).

### Example

```
$ UCM
Universal Serial Bus Configuration Manager, Version V1.0
UCM> SHOW DEVICE /PERMANENT AGA0:
DEVICE
DEVICE_TYPE                PERMANENT
DEVICE_NAME_ROOT           AGA
UNIT_NUMBER                 0
BUS                         1
PATH                       1.0.0.0.0.0
END_DEVICE

UCM> DELETE DEVICE AGA0:
UCM> SHOW DEVICE /PERMANENT AGA0:
%USB-E-NOSUCHDEV, Device name or device unit not found
UCM>
```

In this example, the first `SHOW DEVICE AGA0:` command displays information about the device that is in the permanent list. After the `DELETE DEVICE AGA0:` command, the second `SHOW DEVICE AGA0:` command displays an error message indicating that the device is no longer in the permanent list.

---

**EXIT**

Stops the execution of UCM and returns control to DCL command level. You can also press Ctrl/Z to perform the same function.

**Format**

EXIT

# UCM HELP

---

## HELP

Provides online help for using the UCM commands.

## Format

HELP [command-name]

## Parameter

### **command-name**

The name of a UCM command. When you enter the HELP command with a command name, UCM displays a list of all the command keywords used with the command.

## Example

```
UCM> HELP RESTART  
RESTART
```

```
Restarts the configuration server. Use this command  
only if the server is no longer responding to configuration requests  
or if the server does respond to client commands. To use  
this command, you must have the CMKRNL privilege.
```

```
Format
```

```
RESTART
```

```
Additional information available:
```

```
Qualifiers  
/CONFIRM
```

```
RESTART Subtopic?
```

The HELP RESTART command describes the command, shows its format, and indicates what additional information is available, such as qualifiers. It then prompts you to enter the name of the /CONFIRM qualifier to display information about this qualifier.

## MODIFY DEVICE

Allows you to modify the path and unit number of a device in the permanent list. The changes take place immediately.

Requires SYSPRV privilege.

### Format

MODIFY DEVICE device-name:

### Parameter

**device-name:**

The name of the device whose characteristics are to be modified. The device name has the form *ddcu*,

where:

*dd* is the device code—for example, LP. (The driver name corresponds to the device code; in this case, the driver name would be SYS\$LPDRIVER.)

*c* is the controller designation A through Z; unless UCM specifies a different letter, all USB devices are A.

*u* is the unit number (0 through 9999).

OpenVMS device names are made up of the two-character device code, followed by the controller designation, the unit number (which can be 1 to 4 characters long), and, finally, a colon (:).

### Qualifiers

**/BUS\_NUMBER=number**

Specifies the USB bus number of the device. This parameter is required to identify a particular device on a system that has multiple USB buses. If you do not use this qualifier, the bus number defaults to zero.

The number can be any number from 0 through 25.

**/PATH=(n1[.n2.n3.n4.n5.n6])**

Specifies the path to the device on the bus. The path is used to uniquely identify a device if the device does not have a serial number. The path specification is a series of six or fewer numbers,

where:

*n1* is the number of the root hub (at tier 0).

*n2* through *n6* are port numbers for downstream hubs at tiers 1, 2, 3, 4, and 5.

For example, /PATH=1.4.3 indicates that the device is in turn plugged into port 3 of the second tier, which is plugged into port 4 of the first tier, which in turn is plugged into the root hub 1.

**/UNIT\_NUMBER=number**

Unit numbers can be between 0 and 9999. By default, the configuration code selects the next available unit number. This qualifier allows you to change the unit number to suit your needs.

# UCM

## MODIFY DEVICE

### Example

```
$ UCM
Universal Serial Bus Configuration Manager, Version V1.0
UCM> SHOW DEVICE /UNCONFIGURED

DEVICE
DEVICE_TYPE                TENTATIVE
DEVICE_NAME_ROOT           AGA
UNIT_NUMBER                 0
BUS                         1
PATH                       1.0.0.0.0
END_DEVICE

UCM> ADD DEVICE AGA0:
UCM> MODIFY DEVICE AGA0:/UNIT=9999
UCM> SHOW DEVICE /PERMANENT /FULL AGA9999:

DEVICE
DEVICE_TYPE                PERMANENT
DEVICE_NAME_ROOT           AGA
UNIT_NUMBER                 9999
DRIVER                     SYS$AGDRIVER.EXE
BUS NUMBER                 1
PATH                       1.0.0.0.0
HID_USAGE_DATA             65540
BEGIN_INTERFACE
HID_USAGE_DATA             65540
END_INTERFACE
END_DEVICE

UCM>
```

The first SHOW DEVICE command displays information from the generic list about the unconfigured AG device. The ADD DEVICE command adds the device to the permanent list, and the MODIFY DEVICE command changes the unit number of the device. The second SHOW DEVICE command displays this change.

---

**RELOAD**

Forces the configuration server to reload the configuration data from the generic and permanent device files and to rebuild the lists. This allows you to add a new device type and lets the server find out about it without restarting UCM.

Requires SYSPRV privilege.

**Format**

RELOAD

# UCM RESTART

---

## RESTART

Restarts the configuration server.

---

### Note

---

Use this command only if the server no longer responds to configuration requests or client commands.

---

Requires CMKRNL privilege.

## Format

RESTART

## Qualifier

**/CONFIRM (default)**

**/NOCONFIRM**

Asks you to confirm the restart of the configuration server. If you answer yes, the configuration server is restarted. If you answer no, the operation is not performed.

## Example

```
$ UCM
UCM> RESTART

Restart UCM Server? [N]: yes

Waiting for UCM Server image to exit....
Waiting for UCM Server image to restart....
%USB-S-SRVRESTART, Identification of new UCM Server is 00000217

UCM>
```

Following the RESTART command, UCM prompts you to confirm this command. The system assigns a new identification number to the UCM server when it restarts.



## SET AUTO

Changes the setting of auto-load, auto-perm, or exclude and include lists. When used with no qualifiers, this command causes the UCM server to reload the saved settings from disk.

**Note**

Once a device is made a permanent device, it is always configured and loaded, regardless of the settings for SET AUTO. To remove a permanent device, you must use the DELETE DEVICE command.

### Format

SET AUTO

### Qualifiers

**/ENABLE=(LOAD,PERM)**

**/DISABLE=(LOAD,PERM)**

The /ENABLE and /DISABLE qualifiers allow you to disable or selectively enable automatic loading and automatic permanence for all nonpermanent devices. The two qualifiers have these meanings:

| Qualifier | Explanation  |
|-----------|--|
| /ENABLE   | Allows you to selectively enable automatic loading permanence. Automatic permanence is ignored if automatic loading is disabled. However, you can enable automatic loading and disable automatic permanence. This allows devices to be configured but does not add them to the permanent database. The OpenVMS device name cannot be persistent. |
| /DISABLE  | Allows you to disable device loading on a per-device basis.  |

The following table describes the keywords LOAD and PERM:

| Keyword | Meaning              | Description  |
|---------|----------------------|--|
| LOAD    | Automatic loading    | Allows the device to be automatically configured—that is, the device driver is loaded and an OpenVMS device is created for it.   |
| PERM    | Automatic permanence | Causes the UCM to add the device to the permanent database. Once a device is added to the permanent database, each time it is connected to the system it will have the driver loaded and the device name will always remain the same—that is, it will be persistent. |

By default, LOAD and PERM are enabled. Automatic permanence is ignored if automatic loading is disabled. However, you can enable automatic loading and disable automatic permanence. This allows devices to be configured but does not

## UCM SET AUTO

add them to the permanent database. (The OpenVMS device name might not be persistent in this case.)

**/EXCLUDE=()**

**/INCLUDE=()**

The **/EXCLUDE** and **/INCLUDE** qualifiers allow more explicit control over which devices will be automatically configured.

You can give each qualifier one or more device names, or partial device names. When you provide a partial device name, the trailing characters are wildcarded. You can include an explicit wildcard character (such as an asterisk) to indicate all devices.

UCM examines the exclude list before automatically configuring a device that is not in the permanent database. If the device is on the exclude list, UCM examines the include list to determine whether the device is explicitly included for loading. This allows you to specify a broad range of devices in the exclude list and to specify a narrow set of devices in the include list (see the following example).

### Example

```
$ UCM
UCM> SET AUTO/EXCLUDE=*/INCLUDE=(tx,dn)
UCM> SHOW AUTO
```

```
AUTO LOAD ENABLED
AUTO PERM ENABLED
EXCLUDE = (*)
INCLUDE = (TX, DN)
```

In this example, all devices are excluded with the exception of TX and DN devices. For example, a joystick using AGA0 will not be configured, but a disk DNA0 will be configured, as will TXC2.

## SET LOG

Tells the configuration server to create a new log file. You must use the /NEW qualifier with this command.

Requires OPER privilege.

### Format

```
SET LOG /NEW
```

### Qualifier

#### **/NEW**

Creates a new SYS\$MANAGER:USB\$UCM\_EVENTS.DAT file. This qualifier is required with the SET LOG command.

## UCM SHOW AUTO

---

### SHOW AUTO

Displays the current settings of auto-load, auto-perm, and any exclude or include lists.

### Format

```
SHOW AUTO
```

### Example

```
$ UCM  
UCM> SHOW AUTO
```

```
AUTO LOAD ENABLED  
AUTO PERM ENABLED  
EXCLUDE = (*)  
INCLUDE = (TX, DN)
```

This SHOW AUTO example indicates that all devices are excluded with the exception of TX and DN devices.

---

## SHOW DEVICE

Displays information about devices.

### Format

SHOW DEVICE device-name:

### Parameter

**device-name:**

The name of the device whose characteristics are to be displayed. The device name has the form *ddcu*,

*where:*

*dd* is the device code—for example, LP. (The driver name corresponds to the device code; in this case, the driver name would be SYS\$LPDRIVER.)

*c* is the controller designation A through Z; unless UCM specifies a different letter, all USB devices are A.

*u* is the unit number (0 through 9999.)

OpenVMS device names are made up of the two-character device code, followed by the controller designation, the unit number (which can be 1 to 4 characters long), and, finally, a colon (:).

### Display\_Qualifiers

**/BRIEF (default)**

Displays summary information for each device.

**/FULL**

Displays complete information for each device.

### Selection\_Qualifiers

**/ALL (default)**

Displays all device entries, including those that the /CONFIGURED, /GENERIC, /PERMANENT, /PHYSICAL, and /UNCONFIGURED qualifiers display.

**/CONFIGURED**

Displays all the devices connected to the bus that have been configured successfully.

**/GENERIC**

Displays the devices that are on the generic device list.

**/PERMANENT**

Displays the devices for which the system automatically loads device drivers if the devices are plugged in.

**/PHYSICAL**

Displays the devices that are connected to the bus even if drivers for these devices are not loaded.

## UCM SHOW DEVICE

### **/UNCONFIGURED**

Displays devices that are attached to the bus and that have drivers, but that do not have entries in the permanent list. (These are also known as tentative devices.)

You must execute an ADD DEVICE command to make these devices part of the permanent list. Once the drivers have been added, the device is automatically configured the next time it is plugged in.

### **Example**

```
$ UCM
UCM> SHOW DEVICE /PERMANENT /FULL DNA3:

DEVICE
DEVICE_TYPE                PERMANENT
DEVICE_NAME_ROOT           DNA
UNIT_NUMBER                3
DRIVER                     SYS$DNDRIVER.EXE
USB_CONFIG_TYPE            INTERFACE
VENDOR_ID                  3519
PRODUCT_ID                 768
RELEASE_NUMBER             4352
BUS_NUMBER                 1
PATH                       1.0.0.0.0.0
DEVICE_CLASS               0
DEVICE_SUB_CLASS           0
DEVICE_PROTOCOL            0
NUMBER_OF_INTERFACES      1
CONFIGURATION_VALUE       2
NUMBER_OF_CONFIGURATIONS  1
SERIAL_NUMBER              2B0301060D97A4C8
MANUFACTURER_STRING        QTS
PRODUCT_STRING             USB 2.0 ATAPI Bridge
CONFIGURATION_NUMBER       0
BEGIN_INTERFACE
INTERFACE_CLASS            8
INTERFACE_SUB_CLASS        6
INTERFACE_PROTOCOL         80
END_INTERFACE
END_DEVICE
```

In this example, the SHOW DEVICE command displays complete information about DNA3:.

---

## SHOW EVENTS

Displays important events that occur on the USB bus. Data displayed can include information about device events, such as removals, connections, unrecognized devices, new devices, and so on.

### Format

SHOW EVENTS

### Qualifiers

#### **/BEFORE=time**

Selects events that occurred before the specified time. You can specify *time* as an absolute time, as a combination of absolute and delta times, or as the keyword TODAY (default), TOMORROW, or YESTERDAY. Times are expressed in standard OpenVMS date/time format.

#### **/OUTPUT=file-name**

Writes the selected events to the specified file. By default, output is sent to the current SYS\$OUTPUT device (usually your terminal).

You cannot use the /OUTPUT qualifier with the /PAGE qualifier.

#### **/PAGE**

#### **/NOPAGE (default)**

Controls how information is displayed. /PAGE displays events on one screen at a time.

You cannot use the /PAGE qualifier with the /OUTPUT qualifier.

#### **/PRIORITY=(keyword[,...])**

Selects the event priorities to display. By default, only CRITICAL and NORMAL event priorities are displayed. Additional messages are available as INFORMATIONAL or debug priority information.

The keywords in the following table are valid. CRITICAL and NORMAL are the defaults.

| <b>Keyword</b> | <b>Description</b>                                    |
|----------------|---|
| CRITICAL       | Errors and critical information                       |
| NORMAL         | Normal event reports such as device configuration     |
| INFORMATIONAL  | Additional informational messages from drivers or UCM |
| DBG1           | Debug level 1 information                             |
| DBG2           | Debug level 2 information                             |
| DBG3           | Debug level 3 information                             |
| ALL            | All event priorities                                  |

# UCM

## SHOW EVENTS

### **/SINCE=time**

Selects only those events that occurred on or after the specified time. You can specify time as absolute time, as a combination of absolute and delta times, or as the keyword TODAY (default) or YESTERDAY.

### **/TYPE=event-type**

Selects only the specified type of events. Valid event-types are the following:

|             |   |
|-------------|---|
| ALL         | All event-types (default).                |
| CONFIGURED  | Device was recognized and configured.     |
| DECONFIGURE | Device was removed from the bus.          |
| DRIVER      | Driver events.                            |
| UCM         | UCM server events.                        |
| UNCONFIGURE | Device was recognized but not configured. |
| UNKNOWN     | Event type is unknown.                    |

### **/VALUE=event-number**

Selects only the events specified by the event number. In a future version of this product, you will be able to use this qualifier as an alternative to the /TYPE qualifier for events that do not have an assigned keyword.

## Examples

1. 

```
$ UCM
Universal Serial Bus Configuration Manager, Version V1.0
UCM> SHOW EVENTS
```

| Date        | Time        | Type | Priority | Component  |
|-------------|-------------|------|----------|--|
| 18-JUN-2005 | 22:08:01.09 | UCM  | NORMAL   | SYS\$DZCDRIVER.EXE   |
|             |             |      |          | Message: Tentative device TXD0 proposed... auto-loading driver.            |
| 18-JUN-2005 | 22:08:01.12 | UCM  | NORMAL   | TXD  |
|             |             |      |          | Message: Auto-perm converting tentative device TXD0 into permanent device. |
| 18-JUN-2005 | 22:08:01.53 | UCM  | NORMAL   | SYS\$DZCDRIVER.EXE   |
|             |             |      |          | Message: Tentative device TXD1 proposed... auto-loading driver.            |
| 18-JUN-2005 | 22:08:01.53 | UCM  | NORMAL   | TXD  |
|             |             |      |          | Message: Auto-perm converting tentative device TXD1 into permanent device. |
| 18-JUN-2005 | 22:08:01.88 | UCM  | NORMAL   | SYS\$DZCDRIVER.EXE   |
|             |             |      |          | Message: Tentative device TXD2 proposed... auto-loading driver.            |
| 18-JUN-2005 | 22:08:01.88 | UCM  | NORMAL   | TXD  |
|             |             |      |          | Message: Auto-perm converting tentative device TXD2 into permanent device. |
| 18-JUN-2005 | 22:08:02.33 | UCM  | NORMAL   | SYS\$DZCDRIVER.EXE   |
|             |             |      |          | Message: Tentative device TXD3 proposed... auto-loading driver.            |
| 18-JUN-2005 | 22:08:02.33 | UCM  | NORMAL   | TXD  |
|             |             |      |          | Message: Auto-perm converting tentative device TXD3 into permanent device. |
| 18-JUN-2005 | 22:08:02.72 | UCM  | NORMAL   | SYS\$DZCDRIVER.EXE   |
|             |             |      |          | Message: Tentative device TXD4 proposed... auto-loading driver.            |
| 18-JUN-2005 | 22:08:02.72 | UCM  | NORMAL   | TXD  |
|             |             |      |          | Message: Auto-perm converting tentative device TXD4 into permanent device. |



## UCM SHOW EVENTS

```
18-JUN-2005 22:08:03.21 UCM          NORMAL  SYS$DZCDRIVER.EXE
      Message: Tentative device TXD5 proposed... auto-loading driver.
18-JUN-2005 22:08:03.21 UCM          NORMAL  TXD
      Message: Auto-perm converting tentative device TXD5 into permanent device.
18-JUN-2005 22:08:03.64 UCM          NORMAL  SYS$DZCDRIVER.EXE
      Message: Tentative device TXD6 proposed... auto-loading driver.
18-JUN-2005 22:08:03.64 UCM          NORMAL  TXD
      Message: Auto-perm converting tentative device TXD6 into permanent device.
18-JUN-2005 22:08:04.17 UCM          NORMAL  SYS$DZCDRIVER.EXE
      Message: Tentative device TXD7 proposed... auto-loading driver.
18-JUN-2005 22:08:04.17 UCM          NORMAL  TXD
      Message: Auto-perm converting tentative device TXD7 into permanent device.
18-JUN-2005 22:08:04.30 DRIVER       NORMAL  HUBDRIVER
      Message: Configured device UCE0 using driver SYS$UCEDRIVER:
```

UCM>

This example shows the configuration of a DIGI Edgeport 8-line serial multiplexer. Each line is displayed as the device is loaded and made permanent. The last line displays information related to a special driver that is the actual controller for the Edgeport (UCE0).

To display more device-specific information, use the /PRIORITY=INFORMATIONAL or /PRIORITY=ALL qualifier.

```
2.  $ UCM
     Universal Serial Bus Configuration Manager, Version V1.0
     UCM> SHOW EVENTS/PRIOR=INFORMATIONAL
```

| Date        | Time        | Type   | Priority      | Component |
|-------------|-------------|--|---------------|-----------|
| 18-JUN-2005 | 22:08:00.35 | DRIVER   | INFORMATIONAL | HUBDRIVER |
|             |             | Message: Find a driver for DeviceClass/DeviceSubClass = 0xff/0x0                     |               |           |
| 18-JUN-2005 | 22:08:00.36 | DRIVER   | INFORMATIONAL | HUBDRIVER |
|             |             | Message: Find a driver for InterfaceClass/InterfaceSubClass/Protocol = 0xff/0x0/0xff |               |           |

## UCM SHOW EVENTS

```
18-JUN-2005 22:08:00.47 UNKNOWN      INFORMATIONAL UCM DEVICE UCE
  Message: VENDOR_ID = 5640
          PRODUCT_ID = 15
          RELEASE_NUMBER = 256
          BUS_NUMBER = 0
          PATH = 2.0.0.0.0.0
          DEVICE_CLASS = 255
          DEVICE_SUB_CLASS = 0
          DEVICE_PROTOCOL = 255
          NUMBER_OF_INTERFACES = 1
          CONFIGURATION_VALUE = 1
          INTERFACE_NUMBER = 0
          INTERFACE_PROTOCOL = 255
          INTERFACE_CLASS = 255
          INTERFACE_SUB_CLASS = 0
          NUMBER_OF_CONFIGURATIONS = 1
          SERIAL_NUMBER = V50632832-0\0000
          MANUFACTURER_STRING = Inside Out Networks
          PRODUCT_STRING = Edgeport/8
          CONFIGURATION_NUMBER = 0
          CURRENT_INTERFACE = 0.

18-JUN-2005 22:08:00.47 UCM          INFORMATIONAL SYS$UCEDRIVER.EXE
  Message: Loaded single instance class driver for UCE.

18-JUN-2005 22:08:01.09 UNKNOWN      INFORMATIONAL UCM DEVICE TXD
  Message: BUS_NUMBER = 0
          PATH = 2.0.0.0.0.0
          SERIAL_NUMBER = V50632832-00
          USAGE_TAG = 195893590.

18-JUN-2005 22:08:01.53 UNKNOWN      INFORMATIONAL UCM DEVICE TXD
  Message: BUS_NUMBER = 0
          PATH = 2.0.0.0.0.0
          SERIAL_NUMBER = V50632832-01
          USAGE_TAG = 195893590.

18-JUN-2005 22:08:01.88 UNKNOWN      INFORMATIONAL UCM DEVICE TXD
  Message: BUS_NUMBER = 0
          PATH = 2.0.0.0.0.0
          SERIAL_NUMBER = V50632832-02
          USAGE_TAG = 195893590.

18-JUN-2005 22:08:02.33 UNKNOWN      INFORMATIONAL UCM DEVICE TXD
  Message: BUS_NUMBER = 0
          PATH = 2.0.0.0.0.0
          SERIAL_NUMBER = V50632832-03
          USAGE_TAG = 195893590.

18-JUN-2005 22:08:02.72 UNKNOWN      INFORMATIONAL UCM DEVICE TXD
  Message: BUS_NUMBER = 0
          PATH = 2.0.0.0.0.0
          SERIAL_NUMBER = V50632832-04
          USAGE_TAG = 195893590.

18-JUN-2005 22:08:03.21 UNKNOWN      INFORMATIONAL UCM DEVICE TXD
  Message: BUS_NUMBER = 0
          PATH = 2.0.0.0.0.0
          SERIAL_NUMBER = V50632832-05
          USAGE_TAG = 195893590.

18-JUN-2005 22:08:03.64 UNKNOWN      INFORMATIONAL UCM DEVICE TXD
  Message: BUS_NUMBER = 0
          PATH = 2.0.0.0.0.0
          SERIAL_NUMBER = V50632832-06
          USAGE_TAG = 195893590.
```

## UCM SHOW EVENTS

```
18-JUN-2005 22:08:04.17 UNKNOWN      INFORMATIONAL UCM DEVICE TXD
    Message: BUS NUMBER = 0
           PATH = 2.0.0.0.0.0
           SERIAL NUMBER = V50632832-07
           USAGE_TAG = 195893590.

18-JUN-2005 22:08:04.30 DRIVER        INFORMATIONAL UCEDRIVER
    Message: TXD0 (UCE0 device port 0) configured, opened, and ready

18-JUN-2005 22:08:04.31 DRIVER        INFORMATIONAL UCEDRIVER
    Message: TXD1 (UCE0 device port 1) configured, opened, and ready

18-JUN-2005 22:08:04.31 DRIVER        INFORMATIONAL UCEDRIVER
    Message: TXD2 (UCE0 device port 2) configured, opened, and ready

18-JUN-2005 22:08:04.31 DRIVER        INFORMATIONAL UCEDRIVER
    Message: TXD3 (UCE0 device port 3) configured, opened, and ready

18-JUN-2005 22:08:04.31 DRIVER        INFORMATIONAL UCEDRIVER
    Message: TXD4 (UCE0 device port 4) configured, opened, and ready

18-JUN-2005 22:08:04.31 DRIVER        INFORMATIONAL UCEDRIVER
    Message: TXD5 (UCE0 device port 5) configured, opened, and ready

18-JUN-2005 22:08:04.31 DRIVER        INFORMATIONAL UCEDRIVER
    Message: TXD6 (UCE0 device port 6) configured, opened, and ready

18-JUN-2005 22:08:04.31 DRIVER        INFORMATIONAL UCEDRIVER
    Message: TXD7 (UCE0 device port 7) configured, opened, and ready
```

This SHOW EVENTS example displays /PRIORITY=INFORMATIONAL messages related to the configuration of the 8-port DIGI device from the previous example.

The information provided is usually not shown in order to reduce the amount of output for SHOW EVENTS. However, this information can be useful when you want to see specific information about a device that was configured.



# 11

---

## XA Gateway Control Program Utility (XGCP)

### 11.1 XGCP Description

On OpenVMS Alpha and Integrity servers, the XA Gateway Control Program utility (XGCP) provides the management interface to the DECdtm XA Gateway and creates the transaction logs used by the DECdtm XA Gateway. It can also be used to stop and restart the XA Gateway server.

The Gateway allows a DECdtm-compliant resource manager, such as RMS Journaling or Oracle Rdb, to be used with an XA-compliant transaction manager.

### 11.2 XGCP Commands

The following table summarizes XGCP commands:

| Command      | Description                  |
|--------------|------------------------------|
| CREATE_LOG   | Creates a new XA Gateway log |
| EXIT         | Exits XGCP                   |
| START_SERVER | Starts the XA Gateway server |
| STOP_SERVER  | Stops the XA Gateway server  |

### 11.3 XGCP Usage Summary

#### Format

```
RUN SYS$SYSTEM: XGCP
```

#### Description

To invoke XGCP, enter the following command at the DCL prompt:

```
$ RUN SYS$SYSTEM:XGCP
```

XGCP displays the following prompt, at which you can enter any XGCP command:

```
XGCP>
```

To exit from XGCP, enter the EXIT command at the XGCP prompt, or press Ctrl/Z.

## XGCP CREATE\_LOG

---

### CREATE\_LOG

Creates a new XA Gateway log. Requires SYSPRV privilege or read/write access to the SYS\$JOURNAL directory.

#### Format

```
CREATE_LOG /GATEWAY_NAME=name /SIZE=size
```

#### Parameters

None.

#### Qualifiers

##### **/GATEWAY\_NAME=name**

This qualifier is required. Specify a gateway name of up to 15 characters.

Creates a gateway log named SYS\$JOURNAL:*name*.DDTM\$XG\_JOURNAL. Create a separate Gateway log for each Gateway name under which you want your XA applications to run.

##### **/SIZE=size**

Specifies the initial size of the log, in blocks. If you omit this qualifier, the log is created with an initial size of 242 blocks. The log file is automatically expanded in size when necessary.

#### Example

```
XGCP> CREATE_LOG/GATEWAY_NAME=MYLOG1/SIZE=150
```

The command in this example creates a gateway log named SYS\$JOURNAL:MYLOG1.DDTM\$XG\_JOURNAL. Its initial size is 150 blocks.

---

**EXIT**

Exits XGCP. You can also press Ctrl/Z to exit from XGCP.

**Format**

EXIT

**Parameters**

None.

**Qualifiers**

None.

## XGCP START\_SERVER

---

### START\_SERVER

Starts the XA Gateway server. Requires IMPERSONATE privilege.

#### Format

START\_SERVER

#### Parameters

None.

#### Qualifiers

None.

#### Example

```
XGCP> START_SERVER
```

The command in this example executes the DCL command file SYS\$STARTUP:DDTM\$XG\_STARTUP.COM, which starts the server process called DDTM\$XG\_SERVER.



## **STOP\_SERVER**

Stops the XA Gateway server process, called DDTM\$XG\_SERVER, on the current node.

Requires OPER, SYSPRV and AUDIT privileges.

### **Format**

STOP\_SERVER

### **Parameters**

None.

### **Qualifiers**

None.

### **Example**

```
XGCP> STOP_SERVER
```

The command in this example stops the Gateway server process, called DDTM\$XG\_SERVER.



---

# Supplemental MONITOR Information—Record Formats

The following sections describe the MONITOR record formats.

---

**Note**

---

Contact HP Customer Support to obtain the latest MONITOR record formats.

---

## A.1 The MONITOR Recording File

Binary performance data is written into the MONITOR recording file when a MONITOR request indicates recording. A record is written to this file once per interval for each requested class. The record contains a predefined set of data for each of the requested performance classes.

The recording file is created when a MONITOR request is initiated, and is closed when the request terminates. The MONITOR recording file may be used as a source file to format and display the data on a terminal, to create a summary file, or to record a new recording file with different characteristics.

---

**Note**

---

The record formats described in this section are subject to change without notice at any future OpenVMS release.

---

The MONITOR recording file is an OpenVMS RMS sequential file with variable-length records. Each record in the file begins with a one-byte type field. The remaining fields are different in length and format for each record type. The following list contains three categories of record types:

- Customer control record
- HP control record
- Class record

Customer control records may appear anywhere in the recording file. They are not generated by MONITOR and are ignored by MONITOR when it reads the file.

The first records in the MONITOR recording file, excluding customer control records, are HP control records. The beginning of the file has three types of HP control records: the file header record, the system information record, and the record RMS file name record. Node transition records are also control records, but can appear anywhere in the file.

## Supplemental MONITOR Information—Record Formats

### A.1 The MONITOR Recording File

Class records, which contain data on requested performance classes, follow the HP control records. The class record is generally written once per interval for each class being recorded. An exception to this rule occurs when several class records are required to contain data for a single class over a single interval. This can occur for the PROCESSES class when too many processes exist to be accommodated by the maximum record size.

Unique numbers are assigned to each MONITOR record type. Record type numbers 0–127 are reserved for class records; numbers 128–191 are reserved for HP control records; numbers 192–255 are reserved for customer control records.

MONITOR generates 29 record types. The following table lists the MONITOR record types and their numbers, with associated class types. (For an explanation of MONITOR class types, see Section A.4.1.)

---

#### Note

---

Beginning in OpenVMS Version 8.3, the header include file \$MONDEF provides symbolic constant definitions for the class numbers.

---

| Record Type             | Type Number | Class Type |
|-------------------------|-------------|------------|
| File Header             | 128         |            |
| System Information      | 129         |            |
| Node Transition         | 130         |            |
| RMS File Name           | 131         |            |
| PROCESSES Class         | 0           | component  |
| STATES Class            | 1           | system     |
| MODES Class             | 2           | component  |
| PAGE Class              | 3           | system     |
| IO Class                | 4           | system     |
| FCP Class               | 5           | system     |
| POOL Class <sup>1</sup> | 6           | system     |
| LOCK Class              | 7           | system     |
| DECNET Class            | 8           | system     |
| RESERVED                | 9           | system     |
| RESERVED                | 10          | system     |
| FILE_SYSTEM_CACHE Class | 11          | system     |
| DISK Class              | 12          | component  |
| RESERVED                | 13          | component  |
| DLOCK Class             | 14          | system     |
| SCS Class               | 15          | component  |
| RESERVED                | 16          | system     |
| SYSTEM Class            | 17          | system     |
| RESERVED                | 18          | system     |
| CLUSTER Class           | 19          | system     |

---

<sup>1</sup>POOL class information is available only in pre-Version 6.0 MONITOR recording files.

## Supplemental MONITOR Information—Record Formats

### A.1 The MONITOR Recording File

| Record Type       | Type Number | Class Type |
|-------------------|-------------|------------|
| RMS Class         | 20          | component  |
| MSCP_SERVER Class | 21          | system     |
| TRANSACTION Class | 22          | system     |
| VECTOR Class      | 23          | component  |
| VBS Class         | 24          | system     |
| RESERVED          | 25          | system     |
| RLOCK             | 26          | system     |
| TIMER             | 27          | system     |
| ALIGN             | 28          | system     |

## A.2 Conventions

The following sections define the contents of each field within each record type. Record type and record size are given in decimal representation. References to system time indicate time values in system time format (64-bit format).

The field offset names listed are not defined within MONITOR. However, HP recommends that you define and use these offset names when you work with MONITOR output records.

The following example is the suggested naming convention for the field offset names:

MNR\_CCC\$X\_DDDDD

CCC is a record type or class mnemonic.

X is a one-letter code indicating the size of the data item, as follows:

- B for byte
- W for word
- L for longword
- Q for quadword
- O for octaword
- T for ASCII string

DDDDD is the name describing the data item.

In the following tables that describe the record fields, the size of the data is shown in parentheses following the description of the field contents.

## A.3 HP Control Records

The four types of HP control records are:

- File header record
- System information record
- Node transition record
- RMS file record

Each file has one header record, which contains information applicable to all classes of performance data contained in the file. It must be the first record (except for customer control records) in the file.

## Supplemental MONITOR Information—Record Formats

### A.3 HP Control Records

One system information record exists per node per file. The record contains information about the system being monitored and follows the header record in the file.

#### A.3.1 File Header Record

The file header record has a record type of 128 and a size of 259 bytes.

Figure A–1 illustrates the format of the file header record on Alpha and Integrity servers.

**Figure A–1 File Header Record Format - Alpha and Integrity servers**

|                  |  |                |                        |
|------------------|--|----------------|------------------------|
| MNR_HDR\$L_FLAGS | Flag Bits                              | Type           | MNR_HDR\$B_TYPE        |
|                  |  | Flag Bits      |                        |
|                  | Beginning Time<br>(8 Bytes)            |                | MNR_HDR\$Q_BEGINNING   |
|                  | Ending Time<br>(8 Bytes)               |                | MNR_HDR\$Q_ENDING      |
|                  | Interval                               |                | MNR_HDR\$L_INTERVAL    |
|                  | Revision Level 0 Classes<br>(16 Bytes) |                | MNR_HDR\$O_REV0CLSBITS |
|                  | Record Count                           |                | MNR_HDR\$L_RECCT       |
|                  | Level / Identification                 |                | MNR_HDR\$T_IDENT       |
|                  | Comment<br>(60 Bytes)                  |                | MNR_HDR\$T_COMMENT     |
|                  |  | Comment Length | MNR_HDR\$W_COMLEN      |
|                  | Classes<br>(16 Bytes)                  |                | MNR_HDR\$O_CLASSBITS   |
|                  | Revision Levels<br>(144 Bytes)         |                | MNR_HDR\$T_REVLEVELS   |

VM-1128A-AI

The following table describes the fields in the file header record:

| Field | Symbolic Offset | Contents                         |
|-------|-----------------|----------------------------------|
| Type  | MNR_HDR\$B_TYPE | Record type identifier (1 byte). |

## Supplemental MONITOR Information—Record Formats

### A.3 HP Control Records

| Field                          | Symbolic Offset        | Contents  |
|--------------------------------|------------------------|---|
| Flags                          | MNR_HDR\$L_FLAGS       | Total of 32 flag bits; low-order bit = bit 0. All flags reserved to HP for future use (1 longword).   |
| Beginning Time                 | MNR_HDR\$Q_BEGINNING   | System time of beginning of recording (1 quadword).   |
| Ending Time                    | MNR_HDR\$Q_ENDING      | System time of end of recording (1 quadword).   |
| Interval                       | MNR_HDR\$L_INTERVAL    | Interval in seconds between collections; this is the value specified by the user in the recording request. It is not necessarily equal to the exact interval value obtained by subtracting two consecutive time-stamps for a given class (1 longword).  |
| Revision Level 0 Classes       | MNR_HDR\$O_REV0CLSBITS | A 128-bit string representing all classes; a bit set to 1 indicates the presence in this file of a class which is at revision level 0 and whose type number corresponds to the bit number. Low-order bit = bit 0 (1 octaword). This field is provided for compatibility with OpenVMS VAX Version 3.0 files. |
| Record Count                   | MNR_HDR\$L_RECCT       | Count of all records in the file (1 longword).  |
| Structure Level Identification | MNR_HDR\$T_IDENT       | MONITOR Recording File Structure Level Identification (MON01060 for Version 8.3)(8 bytes).  |
| Comment                        | MNR_HDR\$T_COMMENT     | Recording file description supplied by the user, including trailing blanks (60 bytes).  |
| Comment Length                 | MNR_HDR\$W_COMLEN      | Actual length of recording file description string specified by the user (1 word).  |
| Classes                        | MNR_HDR\$O_CLASSBITS   | A 128-bit string representing all classes; a bit set to 1 indicates the presence in this file of the class whose type number corresponds to the bit number. Low-order bit = bit 0 (1 octaword).   |
| Revision Levels                | MNR_HDR\$T_REVLEVELS   | A 128-byte string consisting of a one-byte binary revision level number for each class. A class has a revision level of 0 initially. For each MONITOR release, if the record definition has changed, the revision level will be increased (not necessarily by 1).   |

## Supplemental MONITOR Information—Record Formats

### A.3 HP Control Records

#### A.3.2 System Information Record

The system information record has a record type of 129 and a size of 47 bytes. Figure A–2 illustrates the format of the system information record on Alpha and Integrity servers.

**Figure A–2 System Information Record Format - Alpha and Integrity servers**

|                   |                          |       |              |                      |
|-------------------|--------------------------|-------|--------------|----------------------|
| MNR_SYI\$W_FLAGS  |                          | Flags | Type         | MNR_SYI\$B_TYPE      |
|                   | Time Booted<br>(8 Bytes) |       |              | MNR_SYI\$Q_BOOTTIME  |
| MNR_SYI\$B_MPCPUS |                          | CPUs  | Max Proc Cnt | MNR_SYI\$W_MAXPRCNT  |
|                   | Node Name<br>(16 Bytes)  |       |              | MNR_SYI\$T_NODENAME  |
|                   | Bal Set Memory           |       |              | MNR_SYI\$L_BALSETMEM |
|                   | MPW High Limit           |       |              | MNR_SYI\$L_MPWHILIM  |
|                   | CPU Type                 |       |              | MNR_SYI\$L_CPUPUTYPE |
|                   |                          |       | Index        | MNR_SYI\$B_INDEX     |
|                   | CPU Conf                 |       |              | MNR_SYI\$L_CPUCONF   |
|                   |                          |       | VPCPUs       | MNR_SYI\$B_VPCPUS    |
|                   | VP Conf                  |       |              | MNR_SYI\$L_VPCONF    |

VM-1129A-AI

The following table describes the fields in the system information record:

| Field           | Symbolic Offset     | Contents  |
|-----------------|---------------------|---|
| Type            | MNR_SYI\$B_TYPE     | Type identifier (1 byte).   |
| Flags           | MNR_SYI\$W_FLAGS    | Total of 16 flag bits; low-order bit = bit 0. If bit 0 is set to 1, the node on which the data was collected is a member of a VAXcluster. All other flags reserved to HP for future use (1 word).               |
| Time Booted     | MNR_SYI\$Q_BOOTTIME | System time at which system booted. MONITOR calculates this time by taking the number of seconds since system boot, converting this to a negative value, and adding it to the current system time (1 quadword). |
| Max Process Cnt | MNR_SYI\$W_MAXPRCNT | MAXPROCESSCNT system parameter value (1 word).  |
| CPUs            | MNR_SYI\$B_MPCPUS   | Number of CPUs (1 byte).  |
| Node Name       | MNR_SYI\$T_NODENAME | Node name of node being monitored (counted ASCII string, 16 bytes).   |



## Supplemental MONITOR Information—Record Formats

### A.3 HP Control Records

| Field                            | Symbolic Offset      | Contents   |
|----------------------------------|----------------------|--|
| Balance Set Memory (Bal Set Mem) | MNR_SYI\$L_BALSETMEM | Number of process pages to which memory can be allocated (1 longword).                     |
| MPW High Limit                   | MNR_SYI\$L_MPWHILIM  | MPW_HILIMIT system parameter value (1 longword).   |
| CPU Type                         | MNR_SYI\$L_CPUATYPE  | CPU type code. Use \$PRDEF macro for code values (1 longword).                             |
| Index                            | MNR_SYI\$B_INDEX     | Identifies the position of this node in several internal MONITOR data structures (1 byte). |
| CPU Config                       | MNR_SYI\$L_CPUCONF   | Bit mask defining the location of each CPU in a multiprocessor (1 longword).               |
| VPCPUs                           | MNR_SYI\$B_VPCPUS    | Number of vector-present processors in the current system (1 byte).                        |
| VP Config                        | MNR_SYI\$L_VPCONF    | Bit mask identifying the vector-present processors in the configuration (1 longword).      |

#### A.3.3 Node Transition Record

The node transition record has a record type of 130 and a size of 2 bytes. Figure A-3 illustrates the format of the node transition record.

**Figure A-3 Node Transition Record Format**

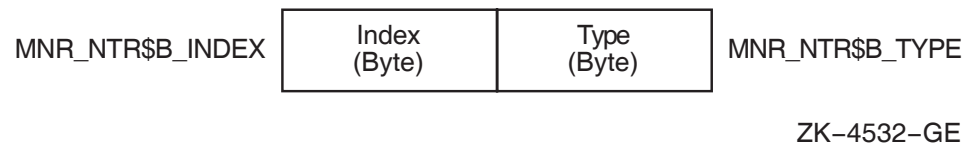

The following table describes the fields in the node transition record:

| Field | Symbolic Offset  | Contents   |
|-------|------------------|--|
| Type  | MNR_NTR\$B_TYPE  | Record type identifier—indicates node removal operation (1 byte).                          |
| Index | MNR_NTR\$B_INDEX | Identifies the position of this node in several internal MONITOR data structures (1 byte). |

#### A.3.4 RMS File Record

The RMS file record has a record type of 131 and a variable size that depends on the number of RMS files and length of the file name string. Figure A-4 illustrates the format of the RMS file record.

## Supplemental MONITOR Information—Record Formats

### A.3 HP Control Records

Figure A-4 RMS File Record Format

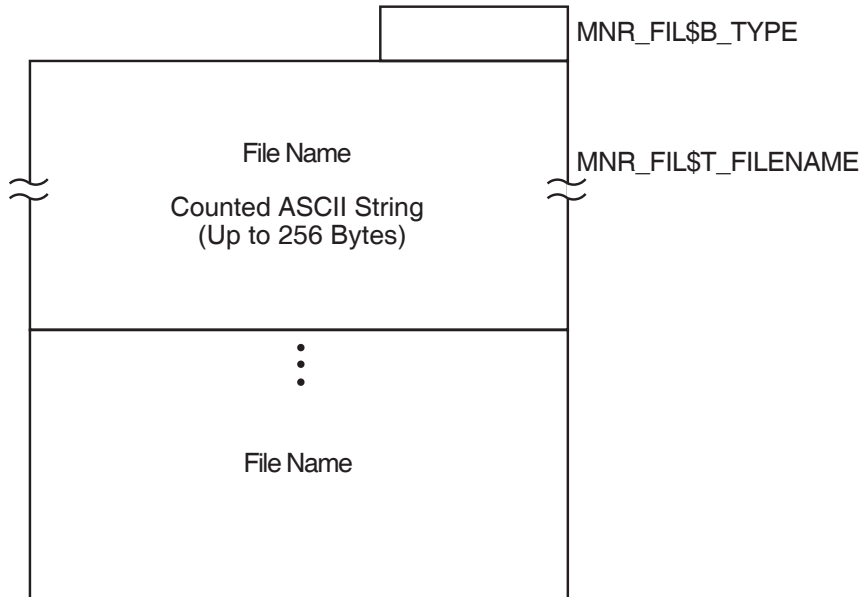

ZK-6107-GE

The following table describes the fields in the RMS file record.

| Field    | Symbolic Offset     | Contents  |
|----------|---------------------|---|
| Type     | MNR_FIL\$B_TYPE     | Record type identifier (1 byte).  |
| Filename | MNR_FIL\$T_FILENAME | A counted ASCII string that identifies the RMS file for MONITOR RMS requests (up to 256 bytes). |

## A.4 Class Records

The MONITOR recording file contains one class record for each requested class for every collection interval, except for the PROCESSES class. (See Section A.4.2.12 for more information about the PROCESSES class records.) For example, if a MONITOR user requested to record five classes (excluding PROCESSES) for a duration of 100 collection intervals, the file would contain 500 class records. Class records occur in order of increasing type number within an interval. The first class record for a given interval follows the last class record for the previous interval.

### A.4.1 Class Type Formats

The two basic class types are system classes and component classes. A class record for a system class generally consists of counts for systemwide activities (such as page faults), whereas a class record for a component class normally contains a count for each element of a measured activity (such as I/O operations for each disk in the system).

Specifically, a class record for a system class consists of a class header followed by a data block. A class record for a component class has a class header followed by a class prefix and one data block per element.

## Supplemental MONITOR Information—Record Formats A.4 Class Records

Figure A-5 illustrates the format for class records.

**Figure A-5 Class Record Format**

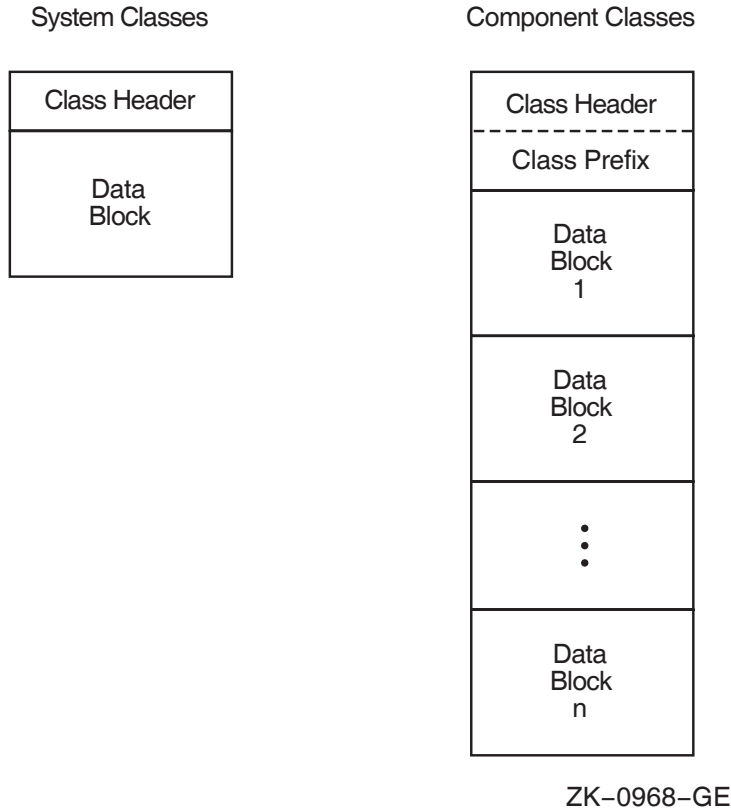

### A.4.1.1 Class Header

The class header is the first part of every class record. Its format is independent of class. On Alpha and Integrity servers, the class header is 16 bytes long; on VAX systems, the class header is 13 bytes long.

Figure A-6 illustrates the format of the class header on Alpha and Integrity servers.

**Figure A-6 Class Header Format - Alpha and Integrity servers**



VM-1130A-AI

## Supplemental MONITOR Information—Record Formats

### A.4 Class Records

The following table describes the fields in the class header:

| Field    | Symbolic Offset     | Contents   |
|----------|---------------------|--|
| Type     | MNR_CLS\$B_TYPE     | Record type identifier (1 byte).   |
| Flags    | MNR_CLS\$B_FLAGS    | Total of 8 flag bits; low order bit = bit 0. If bit 0 is set to 1, the data for this interval continues in the next record. Can be set for the PROCESSES class only. All other flags reserved by HP for future use (1 byte). |
| Index    | MNR_CLS\$B_INDEX    | Identifies the position of this node in several internal MONITOR data structures (1 byte).   |
| Time     | MNR_CLS\$Q_STAMP    | System time at which this class record was recorded. The time value is nondecreasing across all class records in the file.   |
| Reserved | MNR_CLS\$W_RESERVED | Reserved for HP use (1 word).  |

#### A.4.1.2 Class Prefix (Component Classes Only)

The class prefix always follows the class header for component class records. It contains data describing the number of elements (for example, processes for the PROCESSES class, disks for the DISK class) represented by the class records for the current collection interval. Unlike system class records, which have one data block per record, component classes have one data block per element.

One of the class prefix data items describes the number of elements (and therefore the number of data blocks) included in the class record. The other class prefix data item is used only for the PROCESSES class, and describes the number of processes included in the interval. The following discussion applies only to the PROCESSES class.

It is possible to monitor a number of processes so large that the required number of data blocks for one collection interval does not fit into a single maximum size record. In this case, the required number of PROCESSES class records is created to fully describe the processes.

All class headers in the set of PROCESSES class records for a given interval are identical, except for the setting of bit 0 in the MNR\_CLS\$W\_FLAGS field. This bit is set to 1 for all records except the last, for which it is set to 0.

The class prefixes in the set of class records vary, as described in the table following the next figure. The contents of the MNR\_CMP\$L\_ELTCT field depends on the number of data blocks contained in the record; the contents of the MNR\_CMP\$L\_PCTINT field remain constant for each record in the set. All records in the set except the last contain as many data blocks as will fit into the maximum size record (32000 bytes). The last record in the set contains the remaining data blocks.

Figure A-7 illustrates the class prefix format.

## Supplemental MONITOR Information—Record Formats A.4 Class Records

**Figure A-7 Class Prefix Format**

|                       |                   |
|-----------------------|-------------------|
| Elements in Record    | MNR_CMP\$L_ELTCT  |
| Processes in Interval | MNR_CMP\$L_PCTINT |

ZK-0970-GE

The following table describes the fields in the class prefix. The class prefix is 8 bytes long.

| Field                 | Symbolic Offset   | Contents  |
|-----------------------|-------------------|---|
| Elements in Record    | MNR_CMP\$L_ELTCT  | Count of elements (data blocks) in this record (1 longword).  |
| Processes in Interval | MNR_CMP\$L_PCTINT | Count of processes (data blocks) for this interval (1 longword). This field is for the PROCESSES class only. For other component classes, this longword is reserved to HP for future use. |

### A.4.2 Class Data Blocks

The size and format of each data block and the number of blocks per record depend on the class. System classes have one data block per record. Component classes have one data block per element. The fields within each block are performance data items.

The following sections describe the data items within the data block for each class. Every data item falls into one of three categories. It is either a count, a level, or an informational item. A count is a numeric quantity that increases at each succeeding interval for the duration of a system boot. A level is a numeric quantity that may increase or decrease at each succeeding interval. An informational item represents data that, rather than being a unit of performance measurement (as are the first two types), is descriptive in nature.

In the tables that follow, item types are identified by the letters C (count), L (level), and I (informational). Item types are shown in parentheses, following the length of the field. Class records are listed alphabetically.

#### A.4.2.1 CLUSTER Class Record

The CLUSTER class record contains data describing clusterwide CPU, memory, and locking activity. The CLUSTER class record has a record type of 19 and a size of 65 bytes. Note that when the CLUSTER class is recorded, the DISK and MODES classes are also recorded, even if not explicitly requested.

Figure A-8 illustrates the format of the CLUSTER class record.

## Supplemental MONITOR Information—Record Formats

### A.4 Class Records

Figure A–8 CLUSTER Class Record Format

|                          |                        |
|--------------------------|------------------------|
| <b>Header</b>            | Class Header           |
|                          |                        |
| CPU Busy                 | MNR_CLU\$L_CPU_BUSY    |
| Free List Size           | MNR_CLU\$L_FRLIST      |
| Reserved                 | MNR_CLU\$L_RESERVED    |
| Total Locks              | MNR_CLU\$L_TOTAL_LOCKS |
| New ENQ Local            | MNR_CLU\$L_ENQNEWLOC   |
| New ENQ Incoming         | MNR_CLU\$L_ENQNEWIN    |
| New ENQ Outgoing         | MNR_CLU\$L_ENQNEWOUT   |
| ENQ Conversions Local    | MNR_CLU\$L_ENQCVTLOC   |
| ENQ Conversions Incoming | MNR_CLU\$L_ENQCVTIN    |
| ENQ Conversions Outgoing | MNR_CLU\$L_ENQCVTOUT   |
| DEQ Local                | MNR_CLU\$L_DEQLOC      |
| DEQ Incoming             | MNR_CLU\$L_DEQIN       |
| DEQ Outgoing             | MNR_CLU\$L_DEQOUT      |

ZK-4531-GE

The following table describes the fields in the data block for the CLUSTER class record:

| Field            | Symbolic Offset        | Contents  |
|------------------|------------------------|---|
| CPU Busy         | MNR_CLU\$L_CPU_BUSY    | Count of clock ticks (10-millisecond units) spent in all CPU modes since system was booted (longword,C)             |
| Free List Size   | MNR_CLU\$L_FRLIST      | Number of pages currently on the free list (longword,L)   |
| Reserved         | MNR_CLU\$L_RESERVED    | Reserved to HP  |
| Total Locks      | MNR_CLU\$L_TOTAL_LOCKS | Total of all incoming, outgoing, and local ENQs, DEQs, and conversions (longword,C)                                 |
| New ENQ Local    | MNR_CLU\$L_ENQNEWLOC   | Count of new lock requests that originate and are performed on the system (local) (longword,C)                      |
| New ENQ Incoming | MNR_CLU\$L_ENQNEWIN    | Count of new lock requests that originate on other systems and are performed on this system (incoming) (longword,C) |

## Supplemental MONITOR Information—Record Formats A.4 Class Records

| Field                    | Symbolic Offset      | Contents  |
|--------------------------|----------------------|---|
| New ENQ Outgoing         | MNR_CLU\$L_ENQNEWOUT | Count of new lock requests that originate on this system and are performed on other systems (outgoing) (longword,C) |
| ENQ Conversions Local    | MNR_CLU\$L_ENQCVTLOC | Count of lock conversion requests (local) (longword,C)  |
| ENQ Conversions Incoming | MNR_CLU\$L_ENQCVTIN  | Count of lock conversion requests (incoming) (longword,C)   |
| ENQ Conversions Outgoing | MNR_CLU\$L_ENQCVTOUT | Count of lock conversion requests (outgoing) (longword,C)   |
| DEQ Local                | MNR_CLU\$L_DEQLOC    | Count of unlock requests (local) (longword,C)   |
| DEQ Incoming             | MNR_CLU\$L_DEQIN     | Count of unlock requests (incoming) (longword,C)  |
| DEQ Outgoing             | MNR_CLU\$L_DEQOUT    | Count of unlock requests (outgoing) (longword,C)  |

### A.4.2.2 DECNET Class Record

The DECNET class record contains data describing the operation of the DECnet for OpenVMS subsystem. The DECNET class record has a record type of 8 and a size of 36 bytes.

Figure A–9 illustrates the format of the DECNET class record.

**Figure A–9 DECNET Class Record Format**

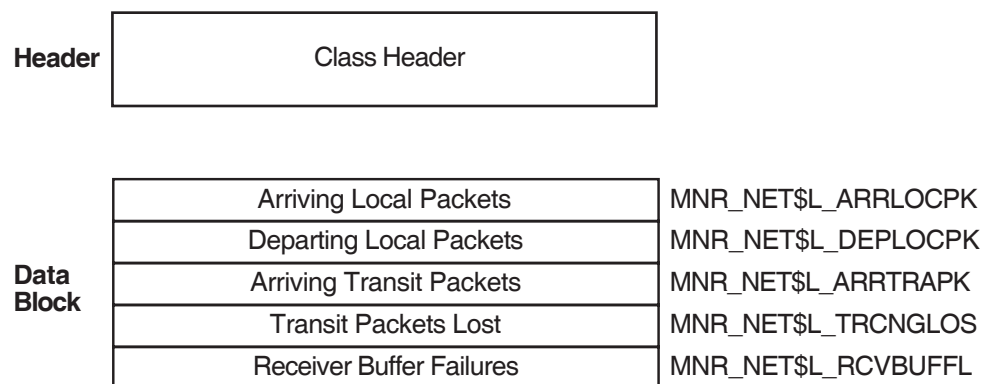

ZK-0979-AI

The following table describes the fields in the data block for the DECNET class record:

## Supplemental MONITOR Information—Record Formats

### A.4 Class Records

| Field                    | Symbolic Offset     | Contents   |
|--------------------------|---------------------|--|
| Arriving Local Packets   | MNR_NET\$L_ARRLOCPK | Count of arriving local packets (longword,C)                     |
| Departing Local Packets  | MNR_NET\$L_DEPLOCPK | Count of departing local packets (longword,C)                    |
| Arriving Transit Packets | MNR_NET\$L_ARRTRAPK | Count of arriving transit packets (longword,C)                   |
| Transit Packets Lost     | MNR_NET\$L_TRCNGLOS | Count of packets lost because of transit congestion (longword,C) |
| Receiver Buffer Failures | MNR_NET\$L_RCVBUFFL | Count of receiver buffer failures (longword,C)                   |

#### A.4.2.3 DISK Class Record

The DISK class record contains data describing all disk devices in the system. The DISK class record has a record type of 12; its size depends on the number of disks being monitored. The size, in bytes, is calculated by adding the size of the class header, the class prefix, and the data blocks contained in the record. This is shown in the following formula:

$$16 + 8 + (44 * \text{the value of MNR\_CMP\$L\_ELTCT})$$

Figure A–10 illustrates the format of the DISK class record on Alpha and Integrity servers.

**Figure A–10 DISK Class Record Format - Alpha and Integrity servers**

|                           |                  |      |  |                     |
|---------------------------|------------------|------|--|---------------------|
| Unit                      | Allocation Class |      | } MNR_DSK\$W_ALLOCLS<br>MNR_DSK\$W_UNIT                |                     |
| Controller                |                  |      |  | MNR_DSK\$T_CTRLR    |
| MBZ                       | Revision         | Flag | } MNR_DSK\$B_FLAGS<br>MNR_DSK\$B_REV<br>MNR_DSK\$B_MBZ |                     |
| Spare1                    |                  |      |  | MNR_DSK\$L_SPARE1   |
| Node Name<br>(8 Bytes)    |                  |      |  | MNR_DSK\$T_NODENAME |
| Volume Name<br>(12 Bytes) |                  |      | MNR_DSK\$T_VOLNAME                                     |                     |
| Operations                |                  |      | MNR_DSK\$L_OPCNT                                       |                     |
| Queue Length              |                  |      | MNR_DSK\$L_IOQUELN                                     |                     |

VM-1131A-AI

The following table describes the fields in the data block for the DISK class record:

| Field            | Symbolic Offset    | Contents                         |
|------------------|--------------------|----------------------------------|
| Allocation Class | MNR_DSK\$W_ALLOCLS | Allocation class number (word,I) |



## Supplemental MONITOR Information—Record Formats A.4 Class Records

| Field        | Symbolic Offset     | Contents  |
|--------------|---------------------|---|
| Controller   | MNR_DSK\$T_CTRLR    | Name of device controller (counted ASCII string) (4 bytes,I)                                  |
| Unit Number  | MNR_DSK\$W_UNITNO   | Unit number (word,I)  |
| Flags        | MNR_DSK\$B_FLAGS    | Total of 8 flag bits; if the low bit is set, the device is served by the MSCP server (byte,I) |
| Spare        | MNR_DSK\$L_SPARE1   | Reserved for future use   |
| Node Name    | MNR_DSK\$T_NODENAME | Name of cluster node where device resides (counted ASCII string) (8 bytes,I)                  |
| Volume Name  | MNR_DSK\$T_VOLNAME  | Volume name of disk (ASCII) (12 bytes,I)  |
| Operations   | MNR_DSK\$L_OPCNT    | Count of I/O operations (longword,C)  |
| Queue Length | MNR_DSK\$L_IOQUELN  | Sum of I/O request queue samples (longword,C)   |

### A.4.2.4 DLOCK Class Record

The DLOCK class record contains data describing the operation of the Distributed Lock Management facility. The DLOCK class record has a record type of 14 and a size of 76 bytes.

Figure A–11 illustrates the format of the DLOCK class record.

## Supplemental MONITOR Information—Record Formats

### A.4 Class Records

Figure A–11 DLOCK Class Record Format

|                   |                             |                     |
|-------------------|-----------------------------|---------------------|
| <b>Header</b>     | Class Header                |                     |
| <b>Data Block</b> | New Locks □ Local           | MNR_DLO\$_ENQNEWLOC |
|                   | New Locks □ Incoming        | MNR_DLO\$_ENQNEWIN  |
|                   | New Locks □ Outgoing        | MNR_DLO\$_ENQNEWOUT |
|                   | Lock Conversions □ Local    | MNR_DLO\$_ENQCVTLOC |
|                   | Lock Conversions □ Incoming | MNR_DLO\$_ENQCVTIN  |
|                   | Lock Conversions □ Outgoing | MNR_DLO\$_ENQCVTOUT |
|                   | Unlocks □ Local             | MNR_DLO\$_DEQLOC    |
|                   | Unlocks □ Incoming          | MNR_DLO\$_DEQIN     |
|                   | Unlocks □ Outgoing          | MNR_DLO\$_DEQOUT    |
|                   | Blocking ASTs □ Local       | MNR_DLO\$_BLKLOC    |
|                   | Blocking ASTs □ Incoming    | MNR_DLO\$_BLKIN     |
|                   | Blocking ASTs □ Outgoing    | MNR_DLO\$_BLKOUT    |
|                   | Functions Incoming          | MNR_DLO\$_DIRIN     |
|                   | Functions Outgoing          | MNR_DLO\$_DIROUT    |
|                   | Deadlock Message Rate       | MNR_DLO\$_DLCKMSG   |

ZK-1349-AI

The following table describes the fields in the data block for the DLOCK class record:

## Supplemental MONITOR Information—Record Formats A.4 Class Records

| Field                            | Symbolic Offset      | Contents  |
|----------------------------------|----------------------|---|
| New Locks<br>—Local              | MNR_DLO\$L_ENQNEWLOC | Count of new lock requests that originate and are performed on this system (local) (longword,C)               |
| New Locks<br>—Incoming           | MNR_DLO\$L_ENQNEWIN  | Count of new lock requests originating on another system and performed on this system (incoming) (longword,C) |
| New Locks<br>—Outgoing           | MNR_DLO\$L_ENQNEWOUT | Count of new lock requests originating on this system and performed on another system (outgoing) (longword,C) |
| Lock Conversions<br>—Local       | MNR_DLO\$L_ENQCVTLOC | Count of lock conversion requests (local) (longword,C)  |
| Lock Conversions<br>—Incoming    | MNR_DLO\$L_ENQCVTIN  | Count of lock conversion requests (incoming) (longword,C)   |
| Lock Conversions<br>—Outgoing    | MNR_DLO\$L_ENQCVTOUT | Count of lock conversion requests (outgoing) (longword,C)   |
| Unlocks—Local                    | MNR_DLO\$L_DEQLOC    | Count of unlock requests (local) (longword,C)   |
| Unlocks—Incoming                 | MNR_DLO\$L_DEQIN     | Count of unlock requests (incoming) (longword,C)  |
| Unlocks—Outgoing                 | MNR_DLO\$L_DEQOUT    | Count of unlock requests (outgoing) (longword,C)  |
| Blocking ASTs<br>—Local          | MNR_DLO\$L_BLKLOC    | Count of lock manager blocking ASTs (local) (longword,C)  |
| Blocking ASTs<br>—Incoming       | MNR_DLO\$L_BLKIN     | Count of lock manager blocking ASTs (incoming) (longword,C)   |
| Blocking ASTs<br>—Outgoing       | MNR_DLO\$L_BLKOUT    | Count of lock manager blocking ASTs (outgoing) (longword,C)   |
| Directory Functions<br>—Incoming | MNR_DLO\$L_DIRIN     | Count of directory functions (incoming) (longword,C)  |
| Directory Functions<br>—Outgoing | MNR_DLO\$L_DIROUT    | Count of directory functions (outgoing) (longword,C)  |
| Deadlock<br>Message Rate         | MNR_DLO\$L_DLCKMSG   | Count of incoming and outgoing lock manager messages required for deadlock detection (longword,C)             |

### A.4.2.5 FCP Class Record

The FCP class record contains data describing the operation of the file system ACPs. The FCP class record has a record type of 5 and a size of 64 bytes.

Figure A–12 illustrates the format of the FCP class record.

## Supplemental MONITOR Information—Record Formats

### A.4 Class Records

Figure A-12 FCP Class Record Format

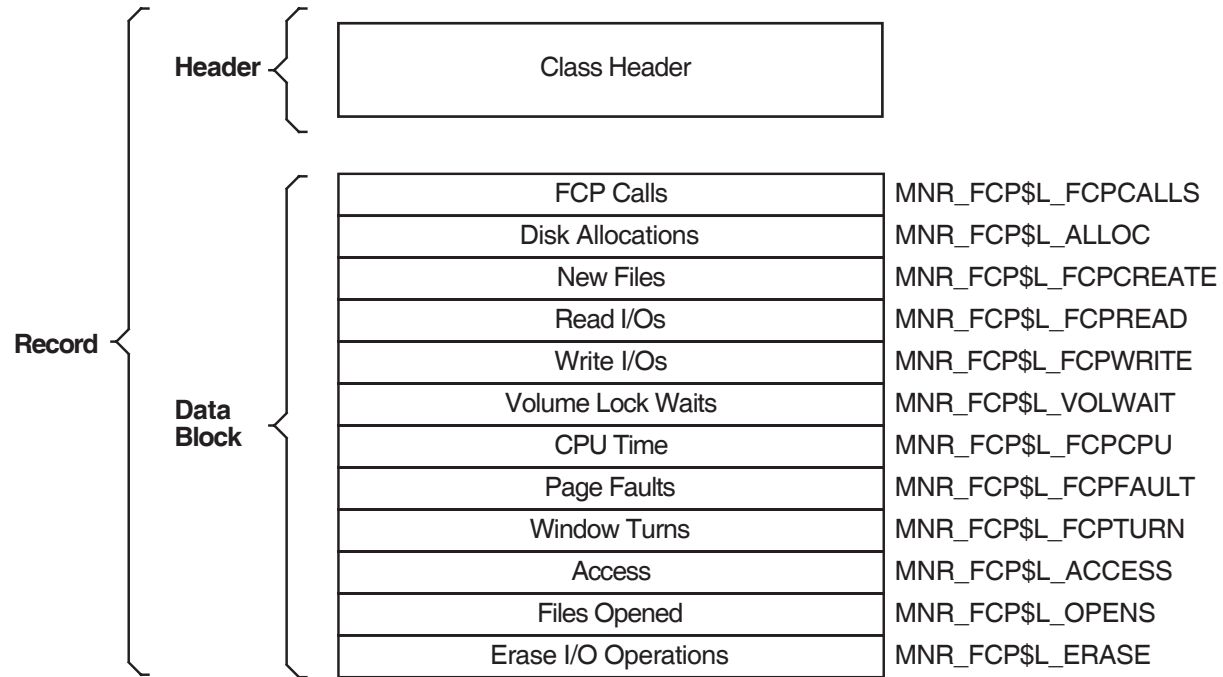

ZK-0976-AI

The following table describes the fields in the data block for the FCP class record:

| Field             | Symbolic Offset      | Contents   |
|-------------------|----------------------|--|
| FCP Calls         | MNR_FCP\$L_FCPCALLS  | Count of QIO requests received by the file system (longword,C)                                 |
| Disk Allocations  | MNR_FCP\$L_ALLOC     | Count of QIO requests that caused allocation of disk space (longword,C)                        |
| New Files         | MNR_FCP\$L_FCPCREATE | Count of new files created (longword,C)  |
| Read I/Os         | MNR_FCP\$L_FCPREAD   | Count of read I/O operations from the disk by the file system (longword,C)                     |
| Write I/Os        | MNR_FCP\$L_FCPWRITE  | Count of write I/O operations to disk by the file system (longword,C)                          |
| Volume Lock Waits | MNR_FCP\$L_VOLWAIT   | Number of times a wait state was entered by the XQP due to volume lock contention (longword,C) |
| CPU Time          | MNR_FCP\$L_FCPCPU    | Count of clock ticks (10-millisecond units) of CPU time used by the file system (longword,C)   |
| FCP Page Faults   | MNR_FCP\$L_FCPFAULT  | Count of page faults for the file system (longword,C)  |
| Window Turns      | MNR_FCP\$L_FCPTURN   | Count of file-map window misses (longword,C)   |
| Access            | MNR_FCP\$L_ACCESS    | Count of file name lookup operations in file directories (longword,C)                          |

## Supplemental MONITOR Information—Record Formats

### A.4 Class Records

| Field                | Symbolic Offset  | Contents  |
|----------------------|------------------|---|
| Files Opened         | MNR_FCP\$L_OPENS | Count of files opened (longword,C)                |
| Erase I/O Operations | MNR_FCP\$L_ERASE | Count of erase I/O operations issued (longword,C) |

#### A.4.2.6 FILE\_SYSTEM\_CACHE Class Record

The FILE\_SYSTEM\_CACHE class record contains data describing the operation of the caches for the file system ACPs and XQPs. The FILE\_SYSTEM\_CACHE class record has a record type of 11 and a size of 72 bytes.

Figure A–13 illustrates the format of the FILE\_SYSTEM\_CACHE class record.

**Figure A–13 FILE\_SYSTEM\_CACHE Class Record Format**

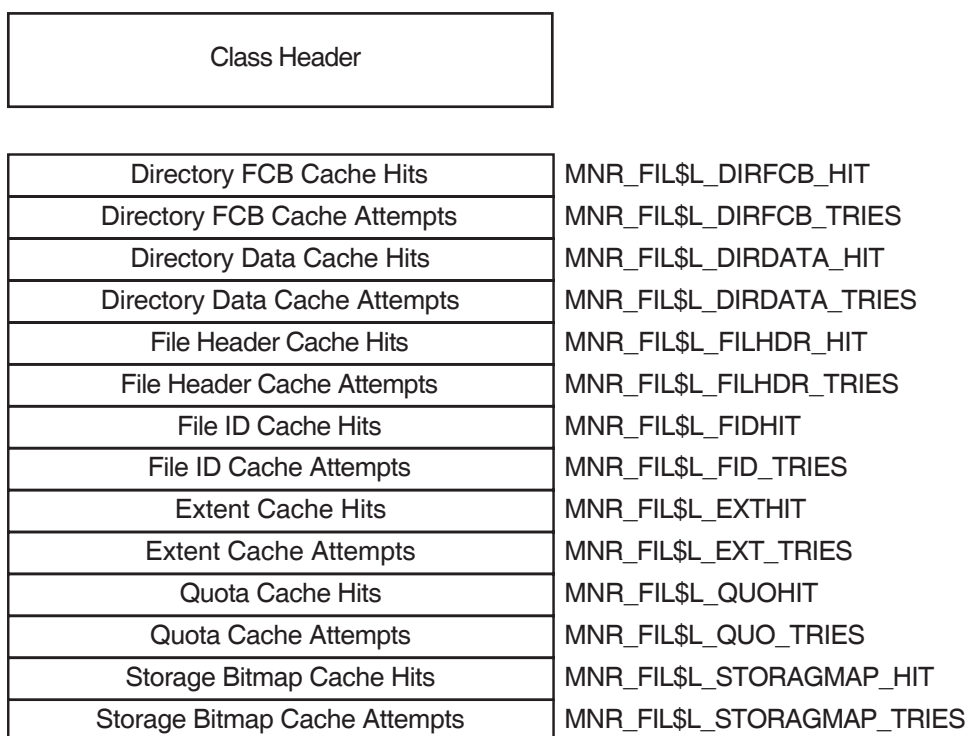

ZK-1985-AI

The following table describes the fields in the data block for the FILE\_SYSTEM\_CACHE class record:

| Field                        | Symbolic Offset         | Contents  |
|------------------------------|-------------------------|---|
| Directory FCB Cache Hits     | MNR_FIL\$L_DIRFCB_HIT   | Count of hits on directory FCB cache (longword,C)     |
| Directory FCB Cache Attempts | MNR_FIL\$L_DIRFCB_TRIES | Count of attempts on directory FCB cache (longword,C) |
| Directory Data Cache Hits    | MNR_FIL\$L_DIRDATA_HIT  | Count of hits on directory data cache (longword,C)    |

## Supplemental MONITOR Information—Record Formats

### A.4 Class Records

| Field                            | Symbolic Offset            | Contents   |
|----------------------------------|----------------------------|--|
| Directory Data<br>Cache Attempts | MNR_FIL\$L_DIRDATA_TRIES   | Count of attempts on directory data cache (longword,C) |
| File Header<br>Cache Hits        | MNR_FIL\$L_FILHDR_HIT      | Count of hits on file header cache (longword,C)        |
| File Header<br>Cache Attempts    | MNR_FIL\$L_FILHDR_TRIES    | Count of attempts on file header cache (longword,C)    |
| File ID<br>Cache Hits            | MNR_FIL\$L_FIDHIT          | Count of hits on file ID cache (longword,C)            |
| File ID<br>Cache Attempts        | MNR_FIL\$L_FID_TRIES       | Count of attempts on file ID cache (longword,C)        |
| Extent Cache<br>Hits             | MNR_FIL\$L_EXTHIT          | Count of hits on extent cache (longword,C)             |
| Extent Cache<br>Attempts         | MNR_FIL\$L_EXT_TRIES       | Count of attempts on extent cache (longword,C)         |
| Quota Cache<br>Hits              | MNR_FIL\$L_QUOHIT          | Count of hits on quota cache (longword,C)              |
| Quota Cache<br>Attempts          | MNR_FIL\$L_QUO_TRIES       | Count of attempts on quota cache (longword,C)          |
| Storage Bitmap<br>Cache Hits     | MNR_FIL\$L_STORAGMAP_HIT   | Count of hits on storage bitmap cache (longword,C)     |
| Storage Bitmap<br>Cache Attempts | MNR_FIL\$L_STORAGMAP_TRIES | Count of attempts on storage bitmap cache (longword,C) |

#### A.4.2.7 I/O Class Record

The I/O class record contains data describing the operation of the I/O subsystem. The I/O class record has a record type of 4 and a size of 72 bytes.

Figure A–14 illustrates the format of the I/O class record.

## Supplemental MONITOR Information—Record Formats A.4 Class Records

**Figure A–14 I/O Class Record Format**

|                   |                           |                    |
|-------------------|---------------------------|--------------------|
| <b>Header</b>     | Class Header              |                    |
| <b>Data Block</b> | Direct I/Os               | MNR_IO\$L_DIRIO    |
|                   | Buffered I/Os             | MNR_IO\$L_BUFIO    |
|                   | Mailbox Writes            | MNR_IO\$L_MBWRITES |
|                   | Split Transfers           | MNR_IO\$L_SPLTRANS |
|                   | Logical Name Translations | MNR_IO\$L_LOGNAM   |
|                   | Files Opened              | MNR_IO\$L_OPENS    |
|                   | Page Faults               | MNR_IO\$L_FAULTS   |
|                   | Page Reads                | MNR_IO\$L_PREADS   |
|                   | Page Read I/Os            | MNR_IO\$L_PREADIO  |
|                   | Page Writes               | MNR_IO\$L_PWRITES  |
|                   | Page Write I/Os           | MNR_IO\$L_PWRITIO  |
|                   | Inswaps                   | MNR_IO\$L_ISWPCNT  |
|                   | Free Page Count           | MNR_IO\$L_FREECNT  |
|                   | Modified Page Count       | MNR_IO\$L_MFYCNT   |

ZK-0975-AI

The following table describes the fields in the data block for the I/O class record:

| Field                     | Symbolic Offset    | Contents   |
|---------------------------|--------------------|--|
| Direct I/Os               | MNR_IO\$L_DIRIO    | Count of direct I/O operations (longword,C)                                    |
| Buffered I/Os             | MNR_IO\$L_BUFIO    | Count of buffered I/O operations (longword,C)                                  |
| Mailbox Writes            | MNR_IO\$L_MBWRITES | Count of write-to-mailbox requests (longword,C)                                |
| Split Transfers           | MNR_IO\$L_SPLTRANS | Count of split transfers (longword,C)  |
| Logical Name Translations | MNR_IO\$L_LOGNAM   | Count of logical name translations (longword,C)                                |
| Files Opened              | MNR_IO\$L_OPENS    | Count of files opened (longword,C)   |
| Page Faults               | MNR_IO\$L_FAULTS   | Count of page faults for all working sets (longword,C)                         |
| Page Reads                | MNR_IO\$L_PREADS   | Count of pages read from disk as a result of page faults (longword,C)          |
| Page Read I/Os            | MNR_IO\$L_PREADIO  | Count of read I/O operations from disk as a result of page faults (longword,C) |
| Page Writes               | MNR_IO\$L_PWRITES  | Count of pages written to the page file (longword,C)                           |

## Supplemental MONITOR Information—Record Formats

### A.4 Class Records

| Field               | Symbolic Offset   | Contents   |
|---------------------|-------------------|--|
| Page Write I/Os     | MNR_IO\$L_PWRITIO | Count of write I/O operations to the page file (longword,C)            |
| Inswaps             | MNR_IO\$L_ISWPCNT | Count of working sets read into memory from the swap file (longword,C) |
| Free Page Count     | MNR_IO\$L_FREECNT | Number of pages currently on free-page list (longword,L)               |
| Modified Page Count | MNR_IO\$L_MFYCNT  | Number of pages currently on modified-page list (longword,L)           |

#### A.4.2.8 LOCK Class Record

The LOCK class record contains data describing the operation of the lock management subsystem. The LOCK class record has a record type of 7 and a size of 56 bytes.

Figure A–15 illustrates the format of the LOCK class record.

**Figure A–15 LOCK Class Record Format**

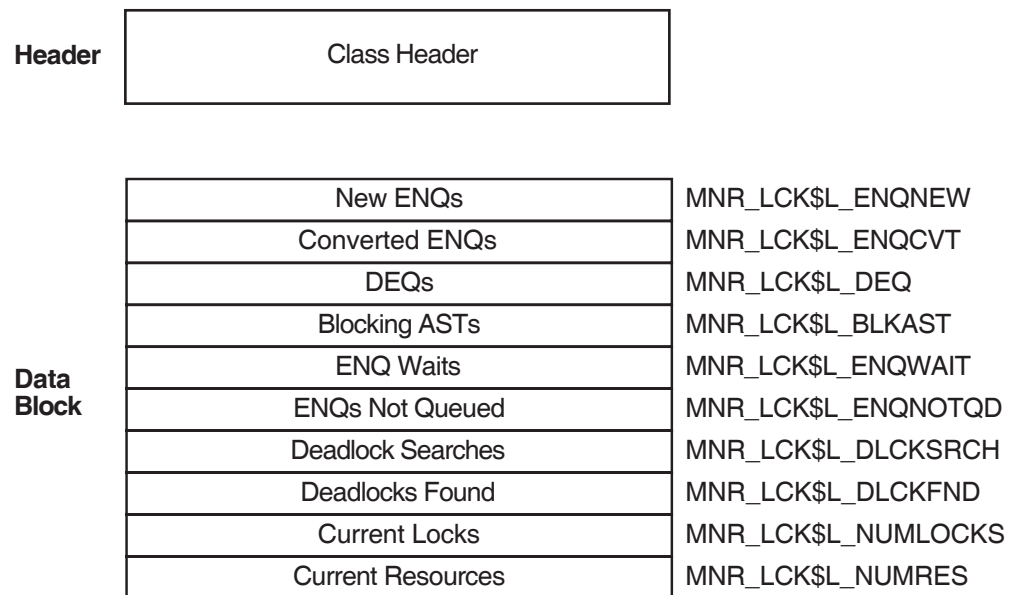

ZK-0978-AI

The following table describes the fields in the data block for the LOCK class record:

| Field          | Symbolic Offset   | Contents  |
|----------------|-------------------|---|
| New ENQs       | MNR_LCK\$L_ENQNEW | Count of new ENQ (lock) requests (longword,C)       |
| Converted ENQs | MNR_LCK\$L_ENQCVT | Count of converted ENQ (lock) requests (longword,C) |
| DEQs           | MNR_LCK\$L_DEQ    | Count of DEQ (unlock) requests (longword,C)         |



## Supplemental MONITOR Information—Record Formats A.4 Class Records

| Field             | Symbolic Offset     | Contents   |
|-------------------|---------------------|--|
| Blocking ASTs     | MNR_LCK\$L_BLKAST   | Count of blocking ASTs queued (longword,C)   |
| ENQ Waits         | MNR_LCK\$L_ENQWAIT  | Count of times a lock could not be granted immediately and waited (longword,C)                                 |
| ENQs Not Queued   | MNR_LCK\$L_ENQNOTQD | Count of times a lock could not be granted immediately and got an error status instead of waiting (longword,C) |
| Deadlock Searches | MNR_LCK\$L_DLCKSRCH | Count of times that a deadlock search was performed (longword,C)   |
| Deadlocks Found   | MNR_LCK\$L_DLCKFND  | Count of times that a deadlock was found (longword,C)  |
| Current Locks     | MNR_LCK\$L_NUMLOCKS | Number of locks currently in the system (longword,L)   |
| Current Resources | MNR_LCK\$L_NUMRES   | Number of resources currently in the system (longword,L)   |

### A.4.2.9 MODES Class Record

The MODES class record contains data describing time spent in each of the processor modes. The MODES class record has a record type of 2; its size depends on the number of active CPUs on the system being monitored. The size, in bytes, is calculated by adding the size of the class header, the class prefix, and the data blocks contained in the record. This is shown in the following formula, which assumes that all CPUs are active:

$$16 + 8 + (36 * \text{MNR\_SYISB\_MPCPUS})$$

Figure A–16 illustrates the format of the MODES class record.

# Supplemental MONITOR Information—Record Formats

## A.4 Class Records

Figure A-16 MODES Class Record Format

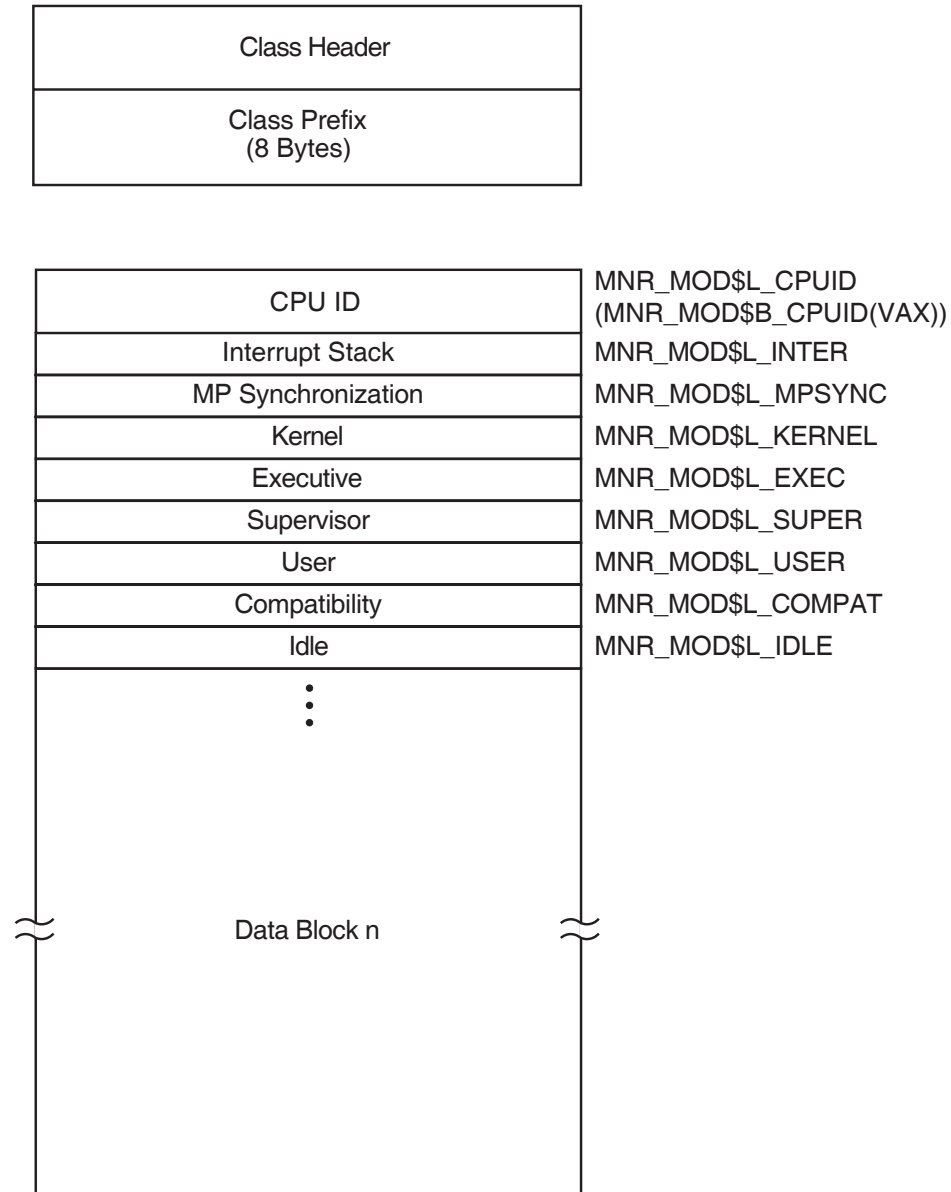

ZK-0973-AI

The following table describes the fields in the data block for the MODES class record:

| Field              | Symbolic Offset   | Contents  |
|--------------------|-------------------|---|
| CPU ID             | MNR_MOD\$L_CPUID  | CPU identification (longword,I)   |
| Interrupt Stack    | MNR_MOD\$L_INTER  | Count of clock ticks (10-millisecond units) spent on interrupt stack since system was booted (longword,C) |
| MP Synchronization | MNR_MOD\$L_MPSYNC | Count of clock ticks spent synchronizing multiple CPUs since system boot                                  |

## Supplemental MONITOR Information—Record Formats A.4 Class Records

| Field         | Symbolic Offset   | Contents  |
|---------------|-------------------|---|
| Kernel        | MNR_MOD\$L_KERNEL | Count of clock ticks spent in kernel mode, excluding interrupt stack time, since system boot (longword,C) |
| Executive     | MNR_MOD\$L_EXEC   | Count of clock ticks spent in executive mode since system boot (longword,C)                               |
| Supervisor    | MNR_MOD\$L_SUPER  | Count of clock ticks spent in supervisor mode since system boot (longword,C)                              |
| User          | MNR_MOD\$L_USER   | Count of clock ticks spent in user mode, excluding compatibility mode time since system boot (longword,C) |
| Compatibility | MNR_MOD\$L_COMPAT | Count of clock ticks boot spent in compatibility mode since system boot (longword,C)                      |
| Idle          | MNR_MOD\$L_IDLE   | Count of clock ticks spent executing the NULL process since system boot (longword,C)                      |

### A.4.2.10 MSCP\_SERVER Class Record

The MSCP\_SERVER class record contains data describing activities of the MSCP server. The MSCP\_SERVER class record has a record type of 21 and a size of 68 bytes.

Figure A–17 illustrates the format of the MSCP\_SERVER class record.

**Figure A–17 MSCP\_SERVER Class Record Format**

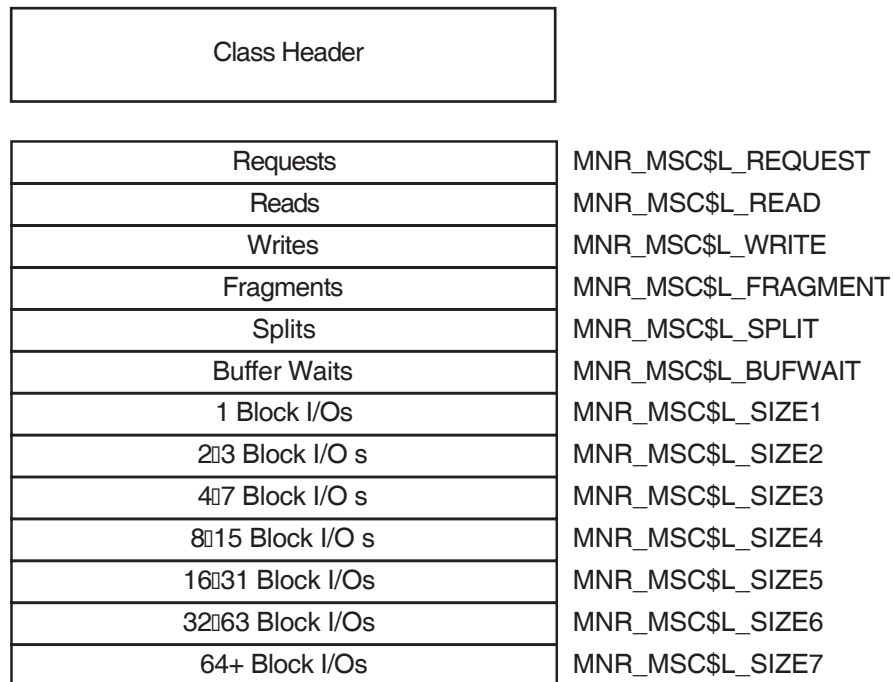

ZK-6374-AI

## Supplemental MONITOR Information—Record Formats

### A.4 Class Records

The following table describes the fields in the data block for the MSCP\_SERVER class record:

| Field            | Symbolic Offset     | Contents  |
|------------------|---------------------|---|
| Requests         | MNR_MSC\$L_REQUEST  | Count of requests for I/O transfers by remote processors (longword,C)               |
| Reads            | MNR_MSC\$L_READ     | Count of requests for Read I/O transfers by remote processors (longword,C)          |
| Writes           | MNR_MSC\$L_WRITE    | Count of requests for Write I/O transfers by remote processors (longword,C)         |
| Fragments        | MNR_MSC\$L_FRAGMENT | Count of extra fragments issued by the server (longword,C)                          |
| Splits           | MNR_MSC\$L_SPLIT    | Count of fragmented requests issued by the server (longword,C)                      |
| Buffer Waits     | MNR_MSC\$L_BUFWAIT  | Count of requests that had to wait for MSCP buffer memory (longword,C)              |
| 1 Block I/Os     | MNR_MSC\$L_SIZE1    | Count of I/O requests with a length of one block (longword,C)                       |
| 2—3 Block I/Os   | MNR_MSC\$L_SIZE2    | Count of I/O requests with a length of 2 to 3 blocks (longword,C)                   |
| 4—7 Block I/Os   | MNR_MSC\$L_SIZE3    | Count of I/O requests with a length of 4 to 7 blocks (longword,C)                   |
| 8—15 Block I/Os  | MNR_MSC\$L_SIZE4    | Count of I/O requests with a length of 8 to 15 blocks (longword,C)                  |
| 16—31 Block I/Os | MNR_MSC\$L_SIZE5    | Count of I/O requests with a length of 16 to 31 blocks (longword,C)                 |
| 32—63 Block I/Os | MNR_MSC\$L_SIZE6    | Count of I/O requests with a length of 32 to 63 blocks (longword,C)                 |
| 64+ Block I/Os   | MNR_MSC\$L_SIZE7    | Count of I/O requests with a length equal to or greater than 64 blocks (longword,C) |

#### A.4.2.11 PAGE Class Record

The PAGE class record contains data describing the operation of the page management subsystem. The PAGE class record has a record type of 3 and a size of 68 bytes.

Figure A–18 illustrates the format of the PAGE class record.

## Supplemental MONITOR Information—Record Formats A.4 Class Records

**Figure A–18 PAGE Class Record Format**

|                   |                           |                      |
|-------------------|---------------------------|----------------------|
| <b>Header</b>     | Class Header              |                      |
| <b>Data Block</b> | Page Faults               | MNR_PAG\$L_FAULTS    |
|                   | Reads                     | MNR_PAG\$L_PREADS    |
|                   | Read I/Os                 | MNR_PAG\$L_PREADIO   |
|                   | Writes                    | MNR_PAG\$L_PWRITES   |
|                   | Write I/Os                | MNR_PAG\$L_PWRITIO   |
|                   | Free Page List Faults     | MNR_PAG\$L_FREFLT    |
|                   | Modified Page List Faults | MNR_PAG\$L_MFYFLT    |
|                   | Demand-Zero Faults        | MNR_PAG\$L_DZROFLT   |
|                   | Global Valid Faults       | MNR_PAG\$L_GVALID    |
|                   | Write in Progress Faults  | MNR_PAG\$L_WRTINPROG |
|                   | System Faults             | MNR_PAG\$L_SYSFAULTS |
|                   | Free Page Count           | MNR_PAG\$L_FREECNT   |
|                   | Modified Page Count       | MNR_PAG\$L_MFYCNT    |

ZK-0974-AI

The following table describes the fields in the data block for the PAGE class record:

| Field                     | Symbolic Offset    | Contents  |
|---------------------------|--------------------|---|
| Page Faults               | MNR_PAG\$L_FAULTS  | Count of page faults for all working set (longword,C)   |
| Reads                     | MNR_PAG\$L_PREADS  | Count of pages read from disk as a result of page faults (longword,C)   |
| Read I/Os                 | MNR_PAG\$L_PREADIO | Count of read I/Os as a result of operations from disk page faults (longword,C)                                       |
| Writes                    | MNR_PAG\$L_PWRITES | Count of pages written to the page file (longword,C)  |
| Write I/Os                | MNR_PAG\$L_PWRITIO | Count of write I/O operations to the page file (longword,C)   |
| Free-page List Faults     | MNR_PAG\$L_FREFLT  | Count of pages read from the free list as a result of page faults (longword,C)  |
| Modified-page List Faults | MNR_PAG\$L_MFYFLT  | Count of pages read from the modified list as a result of page faults (longword,C)                                    |
| Demand-zero Faults        | MNR_PAG\$L_DZROFLT | Count of zero-filled pages allocated as a result of faults (longword,C)   |
| Global Valid Faults       | MNR_PAG\$L_GVALID  | Count of page faults for which the reference page was found to be valid in the system global page tables (longword,C) |

## Supplemental MONITOR Information—Record Formats

### A.4 Class Records

| Field                    | Symbolic Offset      | Contents   |
|--------------------------|----------------------|--|
| Write-in-Progress Faults | MNR_PAG\$L_WRTINPROG | Count of pages read that were in the process of being written back to disk when faulted (longword,C) |
| System Faults            | MNR_PAG\$L_SYSFAULTS | Count of page faults for which the referenced page is in system space (longword,C)                   |
| Free-page Count          | MNR_PAG\$L_FREECNT   | Number of pages currently on free-page list (longword,L)   |
| Modified-page Count      | MNR_PAG\$L_MFYCNT    | Number of pages currently on modified-page list (longword,L)   |

#### A.4.2.12 PROCESSES Class Record

The PROCESSES class record contains data describing all processes in the system. The PROCESSES class record has a record type of 0; its size depends on the number of processes being monitored. The size, in bytes, is calculated by adding the size of the class header, the class prefix, and the data blocks contained in the record. This is shown in the following formulas:

$$13 + 8 + (67 * \text{the value of MNR\_CMP\$L\_ELTCT}) \text{ in OpenVMS Alpha Version 7.3-2}$$

$$16 + 8 + (72 * \text{the value of MNR\_CMP\$L\_ELTCT}) \text{ in OpenVMS Alpha Version 8.2}$$

and Integrity servers Version 8.2-1

$$16 + 8 + (96 * \text{the value of MNR\_CMP\$L\_ELTCT}) \text{ in OpenVMS Alpha and Integrity servers}$$

Version 8.3

Figure A-19 illustrates the format of the PROCESSES class record on Alpha and Integrity servers.

## Supplemental MONITOR Information—Record Formats A.4 Class Records

**Figure A–19 PROCESSES Class Record Format - Alpha and Integrity servers**

|                            |       |                                    |
|----------------------------|-------|------------------------------------|
| Class Header               |       |                                    |
| Class Prefix<br>(8 Bytes)  |       |                                    |
|                            |       |                                    |
| Internal PID               |       | MNR_PRO\$L_IPID                    |
| UIC                        |       | MNR_PRO\$L_UIC                     |
| Priority                   | State | MNR_PRO\$B_PRI<br>MNR_PRO\$W_STATE |
| Process Name<br>(16 Bytes) |       | MNR_PRO\$L_T_LNAME                 |
| Global Page Count          |       | MNR_PRO\$L_GPGCNT                  |
| Process Page Count         |       | MNR_PRO\$L_PPGCNT                  |
| Status Flags               |       | MNR_PRO\$L_STS                     |
| Direct I/Os                |       | MNR_PRO\$L_DIOCNT                  |
| Page Faults                |       | MNR_PRO\$L_PAGEFLTS                |
| CPU Time                   |       | MNR_PRO\$L_CPUTIM                  |
| Buffered IOs               |       | MNR_PRO\$L_BIOCNT                  |
| Extended Process ID        |       | MNR_PRO\$L_EPI D                   |
| Event Flag Wait Mask       |       | MNR_PRO\$L_EFW M                   |
| RBS Transitions            |       | MNR_PRO\$L_RBSTRAN                 |
| Kernel mode time           |       | MNR_PRO\$L_KERNEL_COUNTER          |
| Executive mode time        |       | MNR_PRO\$L_EXECUTIVE_COUNTER       |
| Supervisor mode time       |       | MNR_PRO\$L_SUPERVISOR_COUNTER      |
| User mode time             |       | MNR_PRO\$L_USER_COUNTER            |
| Reserved                   |       | MNR_PRO\$L_RESERVED2               |
| Reserved                   |       | MNR_PRO\$L_RESERVED1               |

VM-1133A-AI

The following table describes the fields in the data block for the PROCESSES class record:

| Field               | Symbolic Offset    | Contents   |
|---------------------|--------------------|--|
| Internal Process ID | MNR_PRO\$L_IPID    | Internal process identification (longword,I)   |
| UIC                 | MNR_PRO\$L_UIC     | User identification code (Group is high-order word; Member is low-order word) (longword,I) |
| State               | MNR_PRO\$W_STATE   | Current scheduling state code (word,I)   |
| Priority            | MNR_PRO\$B_PRI     | Current software priority (complement of 31) (byte,I)                                      |
| Name                | MNR_PRO\$L_T_LNAME | Process name (counted ASCII string) (16 bytes,I)   |
| Global Page Count   | MNR_PRO\$L_GPGCNT  | Current global page count (longword,L)   |
| Process Page Count  | MNR_PRO\$L_PPGCNT  | Current process page count (longword,L)  |

## Supplemental MONITOR Information—Record Formats

### A.4 Class Records

| Field                  | Symbolic Offset               | Contents  |
|------------------------|-------------------------------|---|
| Status Flags           | MNR_PRO\$L_STS                | Software process status flags (PCB\$V_RES bit clear implies swapped out) (longword,I) |
| Direct I/Os            | MNR_PRO\$L_DIOCNT             | Direct I/O count (0 if swapped out) (longword,C)                                      |
| Page Faults            | MNR_PRO\$L_PAGEFLTS           | Page fault count (0 if swapped out) (longword,C)                                      |
| CPU Time               | MNR_PRO\$L_CPUTIM             | Accumulated CPU time, in 10 ms ticks (0 if swapped out) (longword,C)                  |
| Buffered I/Os          | MNR_PRO\$L_BIOCNT             | Buffered I/O count (0 if swapped out) (longword,C)                                    |
| Extended Process ID    | MNR_PRO\$L_EPID               | Extended process identification (longword,I)  |
| Event Flag Weight Mask | MNR_PRO\$L_EFWM               | Event flag wait mask (used for MWAITS) (longword, I)                                  |
| RBS Transitions        | MNR_PRO\$L_RBSTRAN            | Real balance slot transitions (longword, C)   |
| Kernel mode time       | MNR_PRO\$L_KERNEL_COUNTER     | Accumulated kernel mode, in 10-ms ticks   |
| Executive mode time    | MNR_PRO\$L_EXECUTIVE_COUNTER  | Accumulated executive mode, in 10-ms ticks  |
| Supervisor mode time   | MNR_PRO\$L_SUPERVISOR_COUNTER | Accumulated supervisor mode, in 10-ms ticks   |
| User mode time         | MNR_PRO\$L_USER_COUNTER       | Accumulated user mode, in 10-ms ticks   |
| Reserved               | MNR_PRO\$L_RESERVED1          | Reserved for HP internal use  |
| Reserved               | MNR_PRO\$L_RESERVED2          | Reserved for HP internal use  |

#### A.4.2.13 RLOCK Class Record

The RLOCK class record contains data that is useful for monitoring the dynamic lock remastering statistics of a node. The RLOCK class record has a record type of 27 and a size of 44 bytes.

Figure A–20 illustrates the format of the RLOCK class record.



## Supplemental MONITOR Information—Record Formats A.4 Class Records

**Figure A–20 RLOCK Class Record Format**

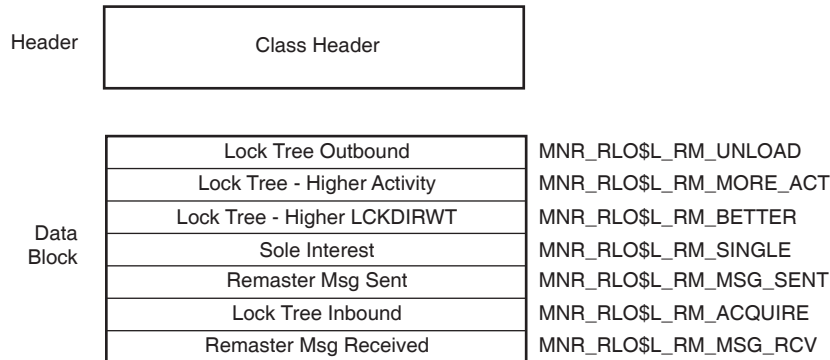

VM-0773A-A1

The following table describes the fields in the data block for the RLOCK class record:

| Field                     | Symbolic Offset        | Contents  |
|---------------------------|------------------------|---|
| Lock Tree Outbound        | MNR_RLO\$L_RM_UNLOAD   | Count of lock trees that are moved from this node.  |
| Lock Tree-Higher Activity | MNR_RLO\$L_RM_MORE_ACT | Count of trees that are moved due to higher locking activity on another node in the cluster.                      |
| Lock Tree-Higher LCKDIRWT | MNR_RLO\$L_RM_BETTER   | Count of trees that are moved to a node with a higher value of the system parameter LCKDIRWT.                     |
| Sole Interest             | MNR_RLO\$L_RM_SINGLE   | Count of trees that are moved to another node because that node is the only one with locks remaining on the tree. |
| Remaster Msg Sent         | MNR_RLO\$L_RM_MSG_SENT | Count of remaster messages sent from this node.   |
| Lock Tree Inbound         | MNR_RLO\$L_RM_ACQUIRE  | Count of trees that are moved to this node.   |
| Remaster Msg Received     | MNR_RLO\$L_RM_MSG_RCV  | Count of remaster messages received on this node.   |

#### A.4.2.14 RMS Class Record

The RMS class record contains data describing Record Management Services for specified files. The RMS class record has a record type of 20. Use the following formula to calculate the record size (the formula calculates the size by adding the size of the class header, the class prefix, and the data blocks contained in the record):

$$16 + 8 + (276 * \text{MNR\_CMP\$L\_ELTCT})$$

## Supplemental MONITOR Information—Record Formats

### A.4 Class Records

Figure A–21 illustrates the format of the RMS class record.

**Figure A–21 RMS Class Record Format**

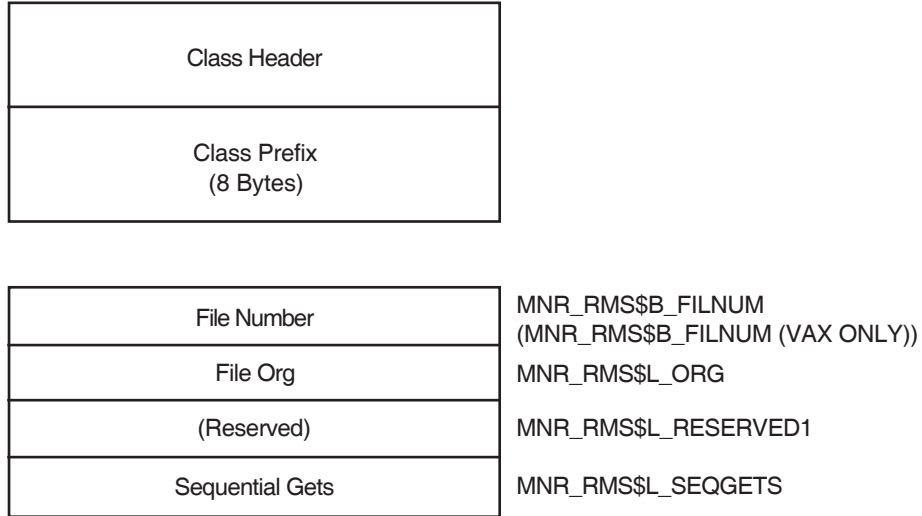

VM-1132A-AI

The following table describes the fields in the data block for the RMS class record:

| Field             | Symbolic Offset      | Contents  |
|-------------------|----------------------|---|
| File Number (Num) | MNR_RMS\$L_FILNUM    | Sequential number of the file (byte,I)              |
| File Organization | MNR_RMS\$L_ORG       | Organization of the file (longword,I)               |
| Reserved          | MNR_RMS\$L_RESERVED1 | Reserved (longword)                                 |
| Sequential GETs   | MNR_RMS\$L_SEQGETS   | Count of sequential \$GETs to the file (longword,C) |

#### A.4.2.15 SCS Class Record

The SCS class record contains data describing SCS (System Communications Services) activity for all SCS connections in the system, on a per-node basis. The SCS class record has a record type of 15; its size depends on the number of nodes being monitored. The size, in bytes, is calculated by adding the size of the class header, the class prefix, and the data blocks contained in the record. This is shown in the following formula:

$$16 + 8 + (56 * \text{the value of MNR\_CMP\$L\_ELTCT})$$

Figure A–22 illustrates the format of the SCS class record.

## Supplemental MONITOR Information—Record Formats A.4 Class Records

**Figure A-22 SCS Class Record Format**

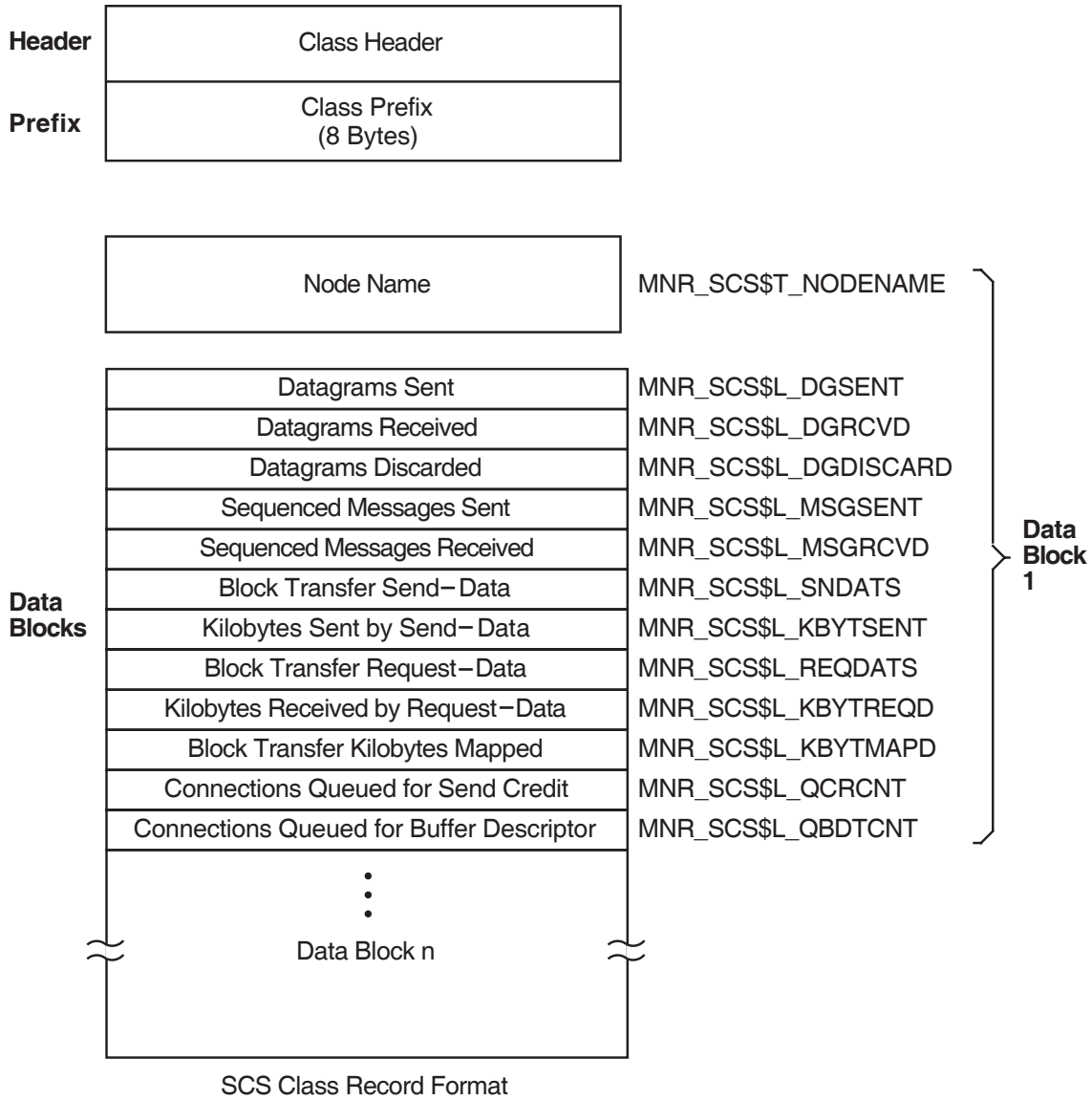

ZK-1670-GE

The following table describes the fields in the data block for the SCS class record:

| Field              | Symbolic Offset                  | Contents   |
|--------------------|----------------------------------|--|
| Node Name          | <code>MNR_SCS\$T_NODENAME</code> | Name of remote cluster node (counted ASCII string) (8 bytes,I) |
| Datagrams Sent     | <code>MNR_SCS\$L_DGSENT</code>   | Count of datagrams sent to the remote node (longword,C)        |
| Datagrams Received | <code>MNR_SCS\$L_DGRCVD</code>   | Count of datagrams received from the remote node (longword,C)  |

## Supplemental MONITOR Information—Record Formats

### A.4 Class Records

| Field  | Symbolic Offset      | Contents   |
|--|----------------------|--|
| Datagrams Discarded                            | MNR_SCS\$L_DGDISCARD | Count of datagrams discarded by the CI port driver (longword,C)  |
| Sequenced Messages Sent                        | MNR_SCS\$L_MSGSENT   | Count of sequenced messages sent to the remote node (longword,C)   |
| Sequenced Messages Received                    | MNR_SCS\$L_MSGRCVD   | Count of sequenced messages received from the remote node (longword,C)   |
| Block Transfer<br>Send-data commands           | MNR_SCS\$L_SNDATS    | Count of block transfer send-data commands initiated on the local node, targeted for the remote node (longword,C)    |
| Kilobytes Sent by<br>Send-data commands        | MNR_SCS\$L_KBYTSENT  | Count of kilobytes sent as a result of send-data commands (longword,C)   |
| Block Transfer Request-<br>data commands       | MNR_SCS\$L_REQDATS   | Count of block transfer request-data commands initiated on the local node, targeted for the remote node (longword,C) |
| Kilobytes Received by<br>Request-data commands | MNR_SCS\$L_KBYTREQD  | Count of kilobytes received as a result of request-data commands (longword,C)  |
| Block Transfer<br>Kilobytes Mapped             | MNR_SCS\$L_KBYTMAPD  | Count of kilobytes mapped for block transfers (longword,C)   |
| Connections Queued For<br>Send Credit          | MNR_SCS\$L_QCRCNT    | Count of times connections are queued for send credits (longword,C)  |
| Connections Queued For<br>Buffer Descriptor    | MNR_SCS\$L_QBDTCNT   | Count of times connections are queued for buffer descriptors (longword,C)  |

#### A.4.2.16 STATES Class Record

The STATES class record contains data describing the number of processes in each of the scheduler states. The STATES class record has a record type of 1 and a size of 72 bytes.

Figure A–23 illustrates the format of the STATES class record.

## Supplemental MONITOR Information—Record Formats A.4 Class Records

**Figure A–23 STATES Class Record Format**

|                   |                              |                  |
|-------------------|------------------------------|------------------|
| <b>Header</b>     | Class Header                 |                  |
| <b>Data Block</b> | Collided Page Wait           | MNR_STA\$L_COLPG |
|                   | Misc. Resource Wait          | MNR_STA\$L_MWAIT |
|                   | Common Event Flag Wait       | MNR_STA\$L_CEF   |
|                   | Page Fault Wait              | MNR_STA\$L_PFW   |
|                   | Local Event Flag, Inswapped  | MNR_STA\$L_LEF   |
|                   | Local Event Flag, Outswapped | MNR_STA\$L_LEFO  |
|                   | Hibernate, Inswapped         | MNR_STA\$L_HIB   |
|                   | Hibernate, Outswapped        | MNR_STA\$L_HIBO  |
|                   | Suspended, Inswapped         | MNR_STA\$L_SUSP  |
|                   | Suspended, Outswapped        | MNR_STA\$L_SUSPO |
|                   | Free Page Wait               | MNR_STA\$L_FPG   |
|                   | Compute State, Inswapped     | MNR_STA\$L_COM   |
|                   | Compute State, Outswapped    | MNR_STA\$L_COMO  |
|                   | Current                      | MNR_STA\$L_CUR   |

ZK-0972-AI

The following table describes the fields in the data block for the STATES class record:

| Field                        | Symbolic Offset  | Contents  |
|------------------------------|------------------|---|
| Collided Page Wait           | MNR_STA\$L_COLPG | Number of processes in collided page wait (longword,L)                |
| Misc Resource Wait           | MNR_STA\$L_MWAIT | Number of processes in miscellaneous resource wait (longword,L)       |
| Common Event Flag Wait       | MNR_STA\$L_CEF   | Number of processes in common event flag wait (longword,L)            |
| Page Fault Wait              | MNR_STA\$L_PFW   | Number of processes in page fault wait (longword,L)                   |
| Local Event Flag, Inswapped  | MNR_STA\$L_LEF   | Number of processes in local event flag wait, inswapped (longword,L)  |
| Local Event Flag, Outswapped | MNR_STA\$L_LEFO  | Number of processes in local event flag wait, outswapped (longword,L) |
| Hibernate, Inswapped         | MNR_STA\$L_HIB   | Number of processes in hibernate wait, inswapped (longword,L)         |
| Hibernate, Outswapped        | MNR_STA\$L_HIBO  | Number of processes in hibernate wait, outswapped (longword,L)        |
| Suspended, Inswapped         | MNR_STA\$L_SUSP  | Number of processes in suspended wait, inswapped (longword,L)         |

## Supplemental MONITOR Information—Record Formats

### A.4 Class Records

| Field                     | Symbolic Offset  | Contents   |
|---------------------------|------------------|--|
| Suspended, Outswapped     | MNR_STA\$L_SUSPO | Number of processes in suspended wait, outswapped (longword,L) |
| Free Page Wait            | MNR_STA\$L_FPG   | Number of processes in free wait (longword,L)                  |
| Compute State, Inswapped  | MNR_STA\$L_COM   | Number of processes in compute state, inswapped (longword,L)   |
| Compute State, Outswapped | MNR_STA\$L_COMO  | Number of processes in compute state, outswapped (longword,L)  |
| Current                   | MNR_STA\$L_CUR   | Number of current processes (longword,L)                       |

#### A.4.2.17 SYSTEM Class Record

The SYSTEM class record contains data describing the overall operation of the three major system components (CPU, memory, I/O). The SYSTEM class record has a record type of 17 and a size of 52 bytes. Note that when the SYSTEM class is recorded, the PROCESSES, STATES, and MODES classes are also recorded, even if not explicitly requested.

Figure A–24 illustrates the format of the SYSTEM class record.

**Figure A–24 SYSTEM Class Record Format**

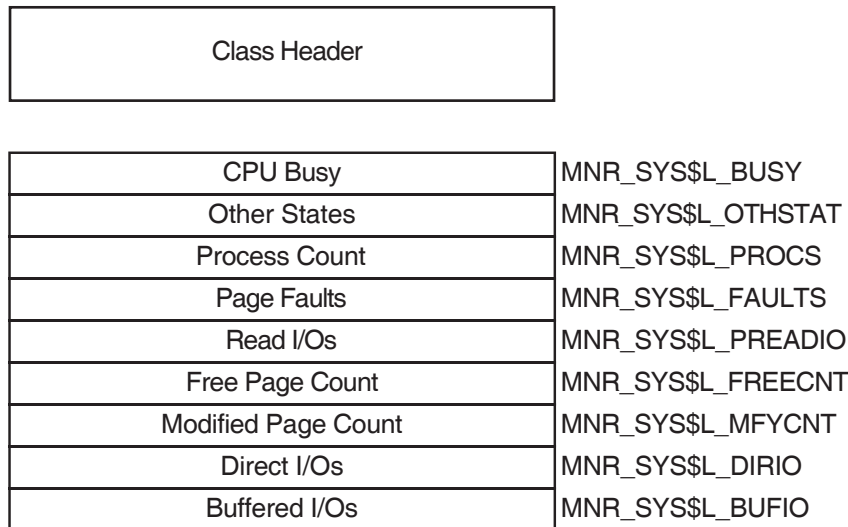

ZK-1986-AI

The following table describes the fields in the data block for the SYSTEM class record:

## Supplemental MONITOR Information—Record Formats A.4 Class Records

| Field               | Symbolic Offset    | Contents  |
|---------------------|--------------------|---|
| CPU Busy            | MNR_SYS\$L_BUSY    | Count of clock ticks (10-millisecond units) spent in all CPU modes since system was booted (longword,C) |
| Other States        | MNR_SYS\$L_OTHSTAT | Number of processes in states other than LEF, LEFO, HIB, HIBO, COM, COMO, PFW, and MWAIT (longword,L)   |
| Process Count       | MNR_SYS\$L_PROCS   | Number of processes in system (longword,L)  |
| Page Faults         | MNR_SYS\$L_FAULTS  | Count of page faults for all working sets (longword,C)  |
| Read I/Os           | MNR_SYS\$L_PREADIO | Count of read I/Os resulting from disk page faults (longword,C)   |
| Free Page Count     | MNR_SYS\$L_FREECNT | Number of pages currently on free-page list (longword,L)  |
| Modified Page Count | MNR_SYS\$L_MFYCNT  | Number of pages currently on modified-page list (longword,L)  |
| Direct I/Os         | MNR_SYS\$L_DIRIO   | Count of direct I/O operations (longword,C)   |
| Buffered I/Os       | MNR_SYS\$L_BUFIO   | Count of buffered I/O operations (longword,C)   |

### A.4.2.18 TIMER Class Record

The TIMER class record contains data that is useful to the OpenVMS executive when monitoring timer queue entries (TQEs). The TIMER class record has a record type of 26 and a size of 32 bytes.

Figure A–25 illustrates the format of the TIMER class record.

**Figure A–25 TIMER Class Record Format**

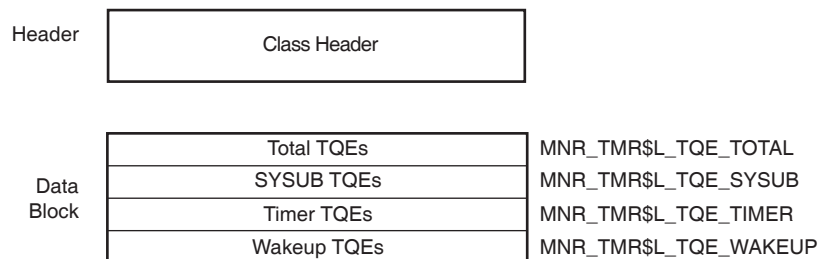

VM-0774A-AI

The following table describes the contents of each of the TIMER class record fields:

## Supplemental MONITOR Information—Record Formats

### A.4 Class Records

| Field       | Symbolic Offset       | Contents   |
|-------------|-----------------------|--|
| Total TQEs  | MNR_TMR\$L_TQE_TOTAL  | Count of all TQEs processed per second.                  |
| SYSUB TQEs  | MNR_TMR\$L_TQE_SYSUB  | Count of SYSUB TQEs processed per second.                |
| Timer TQEs  | MNR_TMR\$L_TQE_TIMER  | Count of timer requests made by users per second.        |
| Wakeup TQEs | MNR_TMR\$L_TQE_WAKEUP | Count of wakeup timer requests made by users per second. |

#### A.4.2.19 TRANSACTION Class Record

The TRANSACTION class record contains data describing the operations of the DECdtm transaction manager. The TRANSACTION class has a record type of 22 and a size of 72 bytes. Figure A–26 illustrates the format of the TRANSACTION class record.

**Figure A–26 TRANSACTION Class Record Format**

|                   |                      |
|-------------------|----------------------|
| Class Header      |                      |
| Starts            | MNR_TRA\$L_STARTS    |
| Prepares          | MNR_TRA\$L_PREPARES  |
| One Phase Commits | MNR_TRA\$L_ONE_PHASE |
| Commits           | MNR_TRA\$L_COMMITS   |
| Aborts            | MNR_TRA\$L_ABORTS    |
| Ends              | MNR_TRA\$L_ENDS      |
| Branches          | MNR_TRA\$L_BRANCHS   |
| Adds              | MNR_TRA\$L_ADDS      |
| 0 1 Transactions  | MNR_TRA\$L_BUCKETS1  |
| 1 2 Transactions  | MNR_TRA\$L_BUCKETS2  |
| 2 3 Transactions  | MNR_TRA\$L_BUCKETS3  |
| 3 4 Transactions  | MNR_TRA\$L_BUCKETS4  |
| 4 5 Transactions  | MNR_TRA\$L_BUCKETS5  |
| 5+ Transactions   | MNR_TRA\$L_BUCKETS6  |

ZK-2023A-AI



## Supplemental MONITOR Information—Record Formats A.4 Class Records

The following table describes the contents of each of the TRANSACTION class record fields:

| Field             | Symbolic Offset      | Contents  |
|-------------------|----------------------|---|
| Starts            | MNR_TRA\$L_STARTS    | Count of transactions started. The number of times that calls on the local node to \$START_TRANS have completed successfully (longword, C). |
| Prepares          | MNR_TRA\$L_PREPARES  | Count of transactions that have been prepared (longword, C).  |
| One Phase Commits | MNR_TRA\$L_ONE_PHASE | Count of one-phase commit events initiated (longword, C).   |
| Commits           | MNR_TRA\$L_COMMITS   | Count of transactions committed. This is the combined total of one-phase and two-phase commits (longword, C).                               |
| Aborts            | MNR_TRA\$L_ABORTS    | Count of transactions aborted. Combined total of planned and unplanned aborts (longword, C).  |
| Ends              | MNR_TRA\$L_ENDS      | Count of transactions ended. The number of times that calls on the local node to \$END_TRANS have completed successfully (longword, C).     |
| Branches          | MNR_TRA\$L_BRANCHS   | Count of transaction branches started on the local node (longword, C).  |
| Adds              | MNR_TRA\$L_ADDS      | Count of transaction branches added on the local node (longword, C).  |
| 0-1 Transactions  | MNR_TRA\$L_BUCKETS1  | Count of transactions with a duration of less than 1 second (longword, C).  |
| 1-2 Transactions  | MNR_TRA\$L_BUCKETS2  | Count of transactions with a duration of 1 to 2 (1.99) seconds (longword, C).   |
| 2-3 Transactions  | MNR_TRA\$L_BUCKETS3  | Count of transactions with a duration of 2 to 3 seconds (longword, C).  |
| 3-4 Transactions  | MNR_TRA\$L_BUCKETS4  | Count of transactions with a duration of 3 to 4 seconds (longword, C).  |
| 4-5 Transactions  | MNR_TRA\$L_BUCKETS5  | Count of transactions with a duration of 4 to 5 seconds (longword, C).  |
| 5+ Transactions   | MNR_TRA\$L_BUCKETS6  | Count of transactions with a duration greater than 5 seconds (longword, C).   |



---

## HP OpenVMS Integrity servers Serial Multiplexer (MUX) Support for Integrity Servers

RS232 serial lines and multiplexers are used for a variety of tasks, from traditional terminal connections to low-speed system-to-system communication and even for communication with remote instruments. OpenVMS has traditionally supported adding serial lines at the same time as option-card-based multiplexers. This solution requires dedicating I/O slots; it also limits the choices of option cards available.

With the widespread adoption of the Universal Serial Bus (USB) on industry-standard platforms, a variety of USB-based serial-line dongles and multiplexers are now available. (Dongles are single-function devices with a connector.) OpenVMS has moved away from option-card-based serial multiplexers and has adopted USB to add serial lines to HP Integrity servers.

USB-based serial devices have many configurations; these vary from single-line dongles to rack-mounted 16-line (or more) multiplexers. Rather than using one or two option-card solutions with 8 or 16 lines for all configurations, you can now configure USB to meet your exact requirements.

Testing shows that the USB-based serial multiplexers perform as well as (or better than) their option-card counterparts and cause very low overhead to the system. In fact, the overhead is lower than option-card-based multiplexers.

### B.1 Conforming Devices

OpenVMS has developed USB interface drivers for the three most popular RS232 chipsets on the market:

- Prolific PL2303
- FTDI FT232AM and FTDI FT232BM
- Inside Out Networks EDGEPORT (from DIGI)

Many sources exist for products based on these chips. OpenVMS has purchased a number of representative products on the open market to validate them. A list of devices that OpenVMS has tested, along with an overview of their capabilities and limitations, is in the section called “Tested Devices.” (OpenVMS intends to continue to update this list regularly and to make it available on its Web page.)

Because consumer products are often short-lived, OpenVMS periodically samples the market for new devices. You can also contact the OpenVMS organization directly at the following Web site to request that a specific product be validated:

<http://h20219.www2.hp.com/services/cache/77481-0-0-225-121.html>

# HP OpenVMS Integrity servers Serial Multiplexer (MUX) Support for Integrity Servers

## B.1 Conforming Devices

For the devices listed in “Tested Devices,” the OpenVMS organization accepts bug reports from customers and produces driver ECO fixes as needed. Driver support for these devices ships with the base operating system and does not require a separate layered-product kit or license.

### Tested Devices

The following devices have been tested on OpenVMS:

- **Inside Out Networks EDGEPORT/416 (DB9) and EDGEPORT/8 (DB25)**
  - The EDGEPORT/416 DB9 (DIGI Part Number 301-1000-10) is a dual RS232 controller with 8 lines per controller (and a total of 16 lines). The device is packaged as two 8-line controllers behind a USB hub; it also provides 4 additional USB expansion ports. The device is powered from a DC adapter integrated on the back of the device.
  - The EDGEPORT/8 DB25 (DIGI Part Number 301-1016-08) is a single RS232 controller with a total of 8 lines. The device is bus powered and does not require an external power supply.

These devices are rack mountable. Both devices have a unique serial number; they are always assigned the same name, regardless of the USB port into which they are plugged. Testing of these devices shows reliable operation in both software flow control and raw binary (no flow control) modes at up to 115,200 baud.

The system parameter `TTY_SILOTIME` controls latency; it trades throughput and system overhead for latency. The default value for `TTY_SILOTIME` is 8. This value is multiplied by 100 and is used to represent the number of times a query is sent to the device for more data after a character transmit or receive.

If no input (or no subsequent output) is seen after 800 responses to the query, the driver stops sending queries to the device and waits for an input interrupt. Reducing the `TTY_SILOTIME` value allows the device to buffer more data, with slightly higher latency.

Increasing the value of `TTY_SILOTIME` makes the device more sensitive to latency but decreases buffering and overall throughput; it also adds more system and USB overhead. Setting `TTY_SILOTIME` to zero causes the driver to send input queries to the device continually. This setting causes the lowest latency, the highest system overhead, and the lowest throughput possible.

---

### Note

---

The `TTY_SILOTIME` system parameter has no effect on Prolific or FTDI devices. The EDGEPORT controller design is different from devices that do not respond to a request until the device has data and a buffer timeout is reached. As a result, input data is buffered whenever possible.

In contrast, the EDGEPORT, responds immediately to input requests regardless of the amount of data available, and sends asynchronous reports about the availability of new data. This allows either a highly buffered implementation or one that is similar to polling.

---

- **Cool Gear (VScom) FTDI 8-Port RS232 (DB9)**

This device (USBGEAR.COM Order Number 8XDB9-USB) is an 8-port DC adapter-powered device that contains 8 individual FDTI FT232BM chips and configures as 8 individual single-line controllers.

## HP OpenVMS Integrity servers Serial Multiplexer (MUX) Support for Integrity Servers B.1 Conforming Devices

The controllers have unique serial numbers and are always assigned the same OpenVMS name, regardless of the USB port into which a controller is plugged.

Tests of this device show reliable operation in both software flow control and raw binary (no flow control) modes at up to 115,200 baud.

- **Prolific PL2303 4-Port RS232 Cable Dongle (DB9)**

This device (USBGEAR.COM Order Number USBG-4X232) is a 4-port wire dongle (4 wires connected to a single USB connector), with 4xDB9 connectors on the wires. The cables contain a USB hub and 4 PL2303 serial controllers. The device is bus powered and does not need a separate power supply.

This device provides no serial number. The persistence of its name is based on where it is plugged (that is, its path topology); when the device is plugged at a different location, it appears to be a different instance of the device.

Tests of this device show reliable operation in both software flow control and raw binary (no flow control) modes at up to 115,200 baud.

- **FTDI 232AM Single-Port RS232 Dongle (DB9)**

This device (USBGEAR.COM Order Number USBG-232MINI) is a single-port dongle (no wire) that plugs into a single USB port. The device is bus powered and needs no external power supply.

The device provides a serial number and is configured with the same OpenVMS device name regardless of where it is plugged.

Tests of the device show reliable operation in both software flow control and raw binary (no flow control) modes at up to 115,200 baud.

- **USBG-4-DOC-1 Multifunction Docking Station**

This multifunction device (USBGEAR.COM Order Number USBG-4-DOC) includes the following:

- 1 Prolific RS232 (DB9) serial port
- A PS2-USB keyboard port converter
- A PS2-USB mouse port converter
- A bidirectional parallel port
- A 4-port USB hub

This device is useful when only a single line is needed and when a parallel port, PS2 keyboard or mouse connectivity, or additional USB ports are required.

The device provides no serial number, and its name persistence is based on where it is plugged (path topology). When the device is plugged in at a different location, it appears to be a different instance of the device.

Tests of this device show reliable operation in both software flow control and in raw binary (no flow control) modes at up to 115,200 baud.

### B.2 Device Installation

The low-range and mid-range Integrity servers provide builtin USB controllers and at least two ports on the system. High-end cell-based systems often do not have builtin USB controllers and sometimes require an optional card (HP Part Number A6869A) to add USB ports.

If no keyboard and mouse are used on the system, you can connect the USB serial device directly to one of the USB ports on the system. The USB design allows expansion of available ports using a hierarchical series of hubs. A hub usually expands an available USB port into 4 USB ports; this means that two ports on most systems can be expanded up to as many as 128 ports by using additional hub devices. By default, OpenVMS recognizes USB devices and configures them automatically (with no additional user action).

UCM assigns USB device names as devices are discovered. When you use multiple similar devices, the order of discovery determines the name. The permanent (persistent name) database obtains the same OpenVMS device name each time the system is booted and the device is found.

Devices that have a unique serial number are always given the same name after they are added to the permanent database. Devices with no serial number are given the same name only when they are plugged into the USB bus hierarchy in the same place as when the name was made persistent. If the device is moved to a different USB port, UCM considers it a new device, and it is given its own unique name.

For more information about controlling USB device configuration, see the *HP OpenVMS System Management Utilities Reference Manual*.

The following actions are required to configure a serial multiplexer:

- Boot the system and then connect the device. (You can connect the device prior to booting as well.)
- By default, OpenVMS automatically detects and connects the device. You can verify this by entering the following command:

```
$ SHOW DEVICE TX
```

The lines are ready to use and are always given the same name or names when OpenVMS VMS boots or when the device is connected. (A device without a serial number, however, is considered to be a different device when it is connected to a different port.)

## SHOW CLUSTER Keypad Commands

SHOW CLUSTER provides a predefined keypad that you can use to enter selected commands. You can add, remove, or reposition windows, scroll their contents, or change the interval at which the display is updated. You can also customize the keypad by redefining the default functions of individual keys.

### C.1 Using the Keypad

By default, the numeric keypad is defined as shown in Figure C–1.

Figure C–1 SHOW CLUSTER Default Keypad

|                                      |   |   |                                 |
|--------------------------------------|---|---|---------------------------------|
| <b>PF1</b><br>GOLD<br>20             | <b>PF2</b><br>HELP<br>10                | <b>PF3</b><br>REFRESH<br>11                             | <b>PF4</b><br>INIT<br>17        |
| <b>7</b><br>SET FUNCTION<br>PAN<br>7 | <b>8</b><br>SET FUNCTION<br>SCROLL<br>8 | <b>9</b><br>SET FUNCTION<br>MOVE<br>9                   | –<br>SET FUNCTION<br>EDIT<br>18 |
| <b>4</b><br>ADD<br>4                 | <b>5</b><br>REMOVE<br>5                 | <b>6</b><br>SET AUTO_POS<br>OFF<br>SET AUTO_POS<br>ON 6 | ,<br>19                         |
| <b>1</b><br>SET<br>1                 | <b>2</b><br>SAVE<br>2                   | <b>3</b><br>WRITE<br>3                                  |                                 |
| <b>0</b><br>0                        | .SELECT<br>DESELECT<br>16               |   | 21                              |

ZK-4997-GE

Shading over a keypad command indicates that you must press the GOLD key and then the keypad key.

## SHOW CLUSTER Keypad Commands

### C.1 Using the Keypad

The following table describes each keypad command you can use with the Show Cluster utility. In this table, KP $n$  refers to the keypad key labeled with the number  $n$ . For example, KP2 refers to the keypad key labeled with the number 2. All commands shown on the keypad are also discussed in the Command Section of Chapter 7.

| Command           | Key or Key Sequence | Description   |
|-------------------|---------------------|---|
| ADD               | KP4                 | Modifies the current display by including the field or class that you specify after the ADD command.  |
| DESELECT          | GOLD-Period         | Terminates a window selection.  |
| GOLD              | PF1                 | When pressed before another keypad key, specifies the second key's alternate function (the bottom function on the keypad diagram).  |
| HELP              | PF2                 | Displays information about using the editing keypad.  |
| INIT              | PF4                 | Resets the display using the original default values for field names, class names, and field widths.  |
| REFRESH           | PF3                 | Refreshes the screen display. Clears and redraws the screen, deleting any extraneous characters or messages that might have appeared on the screen but are not part of the SHOW CLUSTER display. (Performs the same function as Ctrl/W.)      |
| REMOVE            | KP5                 | Modifies the current display by removing the field or class that you specify after the REMOVE command.  |
| SAVE              | KP2                 | Allows you to save the current display to a startup initialization file or a command procedure that you can then use to restore the display at a later time.  |
| SELECT            | Period              | Designates which window to scroll or move.  |
| SET               | KP1                 | Changes any of several options including the number of columns in the display, the number of seconds between updates, the functions of the arrow keys, the auto positioning of windows, and the characteristics of a particular field.        |
| SET AUTO_POS OFF  | KP6                 | Disables the automatic positioning of windows on the screen.  |
| SET AUTO_POS ON   | GOLD-KP6            | Enables the Show Cluster utility to automatically position windows on the screen. This is the default setting.  |
| SET FUNCTION EDIT | Hyphen              | Redefines the arrow keys to restore line-mode editing.  |
| SET FUNCTION MOVE | KP9                 | Redefines the arrow keys to move a selected window to a specified position on the display screen. For example, the UP, DOWN, RIGHT, and LEFT arrow keys are redefined as MOVE UP 1, MOVE DOWN 1, MOVE RIGHT 1, and MOVE LEFT 1, respectively. |
| SET FUNCTION PAN  | KP7                 | Redefines the arrow keys to rotate the display. For example, the UP, DOWN, RIGHT, and LEFT arrow keys are redefined as PAN UP 1, PAN DOWN 1, PAN RIGHT 1, and PAN LEFT 1, respectively.   |



## SHOW CLUSTER Keypad Commands

### C.1 Using the Keypad

---

| Command                | Key or Key Sequence | Description   |
|------------------------|---------------------|---|
| SET FUNCTION<br>SCROLL | KP8                 | Resets the arrow keys to scroll the screen display. For example, if you press the SET FUNCTION SCROLL key, the UP, DOWN, RIGHT, and LEFT arrow keys are redefined as SCROLL UP 1, SCROLL DOWN 1, SCROLL RIGHT 1, and SCROLL LEFT 1, respectively. |
| WRITE                  | KP3                 | Outputs the current display to either a file name that you specify, or to the default output file name SHOW_CLUSTER.LIS.  |

---

### C.2 Redefining the Keypad Keys

Use the DEFINE/KEY command to change the definition of a key. See the DEFINE/KEY command in the Command Section of Chapter 7 for more information.

### C.3 Redefining the Arrow Keys

By default, the SHOW CLUSTER arrow keys are set to the EDIT function. This means that you can perform command line editing at the command prompt that is similar to DCL line-mode editing. For example, the left arrow key moves the cursor to the left, or the up arrow key recalls the previous command. See the *OpenVMS User's Manual* for information about DCL line-mode editing.

The SET FUNCTION keys, shown in the second row of the keypad, redefine the arrow keys to perform a specified function. You can reset the arrow keys from EDIT to PAN, SCROLL, or MOVE with the SET FUNCTION command. For example, if you press the SET FUNCTION SCROLL key, the up, down, right, and left arrow keys are redefined as SCROLL UP 1, SCROLL DOWN 1, SCROLL RIGHT 1, and SCROLL LEFT 1, respectively. (See the Command Section of Chapter 7 for information about specific commands.)

---

#### Note

---

If you set the function to PAN, SCROLL, or MOVE, the arrow keys are no longer defined to perform DCL line-mode editing. Only one function can be enabled at a time. To restore line-mode editing once it has been changed to another function, enter the command SET FUNCTION EDIT.

---



---

## System Parameters

This appendix describes OpenVMS system parameters.

---

### Note

HP recommends that you use AUTOGEN to modify system parameters. In special cases, however, you can use a conversational boot to modify a parameter value temporarily. To change a parameter value permanently, you must edit MODPARAMS.DAT and run AUTOGEN. For instructions, see the *HP OpenVMS System Manager's Manual*.

---

## D.1 How the Parameters are Described

System parameters can be grouped into categories, as shown in Section D.1.1. Each parameter can have one or more attributes, listed in Section D.1.1. Each parameter also has a value.

The parameters in this appendix are listed alphabetically along with their attributes.

### D.1.1 Parameter Categories and Attributes

The system parameters can be divided into the following categories:

| Category | Description  |
|----------|--|
| ACP      | Parameters associated with file system caches and Files-11 ancillary control processes (ACPs).   |
| CLUSTER  | Parameters that affect OpenVMS Cluster operation.  |
| JOB      | Job control parameters.  |
| LGI      | Login security parameters.   |
| PQL      | Parameters associated with process creation limits and quotas.   |
| RMS      | Parameters associated with OpenVMS Record Management Services (RMS).   |
| SCS      | Parameters that control System Communications Services (SCS) and port driver operation. The parameters that affect SCS operation have the prefix SCS. The parameters that affect the CI780/CI750 port driver have the prefix PA. |
| SPECIAL  | Special parameters used by HP. Change these parameters only if recommended by HP personnel, or if specifically instructed in the installation guide or release notes of an HP layered product.                                   |
| SYS      | Parameters that affect overall system operation.   |
| TTY      | Parameters associated with terminal behavior.  |

## System Parameters

### D.1 How the Parameters are Described

The user can also define four parameters: USERD1, USERD2, USER3, and USER4. The USERD1 and USERD2 parameters are dynamic.

#### Attributes for Parameters

Parameters can have one or more of the following attributes:

| Attribute | Description   |
|-----------|---|
| AUTOGEN   | AUTOGEN calculates and modifies values.                                       |
| DYNAMIC   | Active values can be modified.  |
| FEEDBACK  | FEEDBACK information available for AUTOGEN calculations.                      |
| GEN       | Affects the creation and initialization of data structures at bootstrap time. |
| MAJOR     | Most likely to require modification.  |

These attributes are noted in the detailed parameter descriptions in Section D.2.

#### D.1.2 Values for Parameters

Each parameter has associated default, minimum, and maximum values that define the scope of allowable values. To determine these values, invoke SYSGEN and enter a SHOW [parameter-name] command (with appropriate qualifiers). For example, to display the values for WSMAX, specify SHOW WSMAX; to display the values for the TTY parameters, specify SHOW/TTY. You can also display parameters grouped by attributes. To display DYNAMIC parameters, for example, specify SHOW/DYNAMIC.

Default values for system parameters allow booting on any supported OpenVMS configuration. SYSGEN displays default values under the heading default when you enter the SYSGEN command SHOW [parameter-name] for one of the parameter categories or attributes. Reset the default parameter values with the USE DEFAULT command.

However, to avoid starting all layered products on a system that is not tuned for them, possibly causing the system to become nonoperational, set the STARTUP\_P1 system parameter to "MIN."

The computed, installed value referred to in this section is the value derived by the AUTOGEN command procedure. (See the *HP OpenVMS System Manager's Manual*.)

## D.2 Parameter Descriptions

This section describes system parameters and provides guidelines to help you decide whether you should consider modifying the parameters. The following attributes are indicated for the parameters:

AUTOGEN—A  
DYNAMIC—D  
FEEDBACK—F  
GEN—G  
MAJOR—M

---

#### Note

---

In versions of the operating system before Version 4.0, a separate process, the ancillary control process (ACP), performed file operations such as

file opens, closes, and window turns. Version 4.0 introduced the XQP (extended QIO procedure), which allows every process on the system to perform these operations. Consequently, many ACP parameters are applicable only when Files-11 On-Disk Structure Level 1 disks are mounted or when an ACP is specifically requested during a mount command. For compatibility reasons, the names of the parameters have not changed.

---

### D.2.1 System Parameters

This section alphabetically lists and describes the system parameters in all categories.

#### Parameters

##### **ACP\_BASEPRIO (D)**

ACP\_BASEPRIO sets the base priority for all ACPs. The DCL command SET PROCESS/PRIORITY can be used to reset the base priorities of individual ACPs. ACP\_BASEPRIO is not applicable for XQPs.

##### **ACP\_DATACHECK (D)**

ACP\_DATACHECK controls the consistency checks that are performed on internal file system metadata such as file headers.

ACP\_DATACHECK is a bit mask. The following table shows the bits that are defined currently:

| Bit | Description  |
|-----|--|
| 0   | Set this bit to perform consistency checks on read operations.<br>When this bit is set, the IO\$M_DATACHECK function modifier is automatically set on all subsequent IO\$_READLBLK operations that read file system metadata (see the <i>OpenVMS I/O User's Reference Manual</i> ).  |
| 1   | Set this bit to perform consistency checks on write operations.<br>When this bit is set, the IO\$M_DATACHECK function modifier is automatically set on all subsequent IO\$_WRITELBLK operations that read file system metadata (see the <i>OpenVMS I/O User's Reference Manual</i> ).  |
| 2   | Set this bit to perform read-after-write consistency checks.<br>This is similar to setting bit 1, except that in this case the file system does the checks, not the lower level device or disk driver.<br>Note that read-after-write consistency checks are not allowed on deferred writes. Deferred writes are turned off if this bit is set. |
| 3   | Reserved for HP use only; must be zero.  |
| 4   | Reserved for HP use only; must be zero.  |

## System Parameters

### D.2 Parameter Descriptions

| Bit  | Description   |                        |                      |                        |                 |   |   |   |   |   |   |   |   |  |   |   |   |  |   |   |   |
|--|---|------------------------|----------------------|------------------------|-----------------|---|---|---|---|---|---|---|---|--|---|---|---|--|---|---|---|
| 5 and 6  | These two bits control the checks that are performed on reads and writes of directory blocks. You can select one of four different levels:  |                        |                      |                        |                 |   |   |   |   |   |   |   |   |  |   |   |   |  |   |   |   |
|  | <table border="1"> <thead> <tr> <th>To Check That...</th> <th>Select This Level...</th> <th>By Setting Bit 6 to...</th> <th>And Bit 5 to...</th> </tr> </thead> <tbody> <tr> <td>The block is a valid directory block (reads only)</td> <td>0</td> <td>0</td> <td>0</td> </tr> <tr> <td>The block is a valid directory block (reads and writes)</td> <td>1</td> <td>0</td> <td>1</td> </tr> <tr> <td>The block is a valid directory block and contains valid entries (reads and writes)</td> <td>2</td> <td>1</td> <td>0</td> </tr> <tr> <td>The block is a valid directory block and contains valid entries in correct alphanumeric order (reads and writes)</td> <td>3</td> <td>1</td> <td>1</td> </tr> </tbody> </table> | To Check That...       | Select This Level... | By Setting Bit 6 to... | And Bit 5 to... | The block is a valid directory block (reads only) | 0 | 0 | 0 | The block is a valid directory block (reads and writes) | 1 | 0 | 1 | The block is a valid directory block and contains valid entries (reads and writes) | 2 | 1 | 0 | The block is a valid directory block and contains valid entries in correct alphanumeric order (reads and writes) | 3 | 1 | 1 |
| To Check That...   | Select This Level...  | By Setting Bit 6 to... | And Bit 5 to...      |                        |                 |   |   |   |   |   |   |   |   |  |   |   |   |  |   |   |   |
| The block is a valid directory block (reads only)  | 0   | 0                      | 0                    |                        |                 |   |   |   |   |   |   |   |   |  |   |   |   |  |   |   |   |
| The block is a valid directory block (reads and writes)  | 1   | 0                      | 1                    |                        |                 |   |   |   |   |   |   |   |   |  |   |   |   |  |   |   |   |
| The block is a valid directory block and contains valid entries (reads and writes)                               | 2   | 1                      | 0                    |                        |                 |   |   |   |   |   |   |   |   |  |   |   |   |  |   |   |   |
| The block is a valid directory block and contains valid entries in correct alphanumeric order (reads and writes) | 3   | 1                      | 1                    |                        |                 |   |   |   |   |   |   |   |   |  |   |   |   |  |   |   |   |
|  | <p>When you set the <code>SYSTEM_CHECK</code> system parameter to 1, you enable level 3 checking of directory blocks.</p> <p>Write errors result in <code>BUGCHECK</code> and crash your system; read errors exit with error status <code>SS\$_BADDIRECTORY</code>.</p>   |                        |                      |                        |                 |   |   |   |   |   |   |   |   |  |   |   |   |  |   |   |   |
| 7  | Reserved for HP use only; must be zero.   |                        |                      |                        |                 |   |   |   |   |   |   |   |   |  |   |   |   |  |   |   |   |

#### **ACP\_DINDXCACHE (A,D,F)**

`ACP_DINDXCACHE` controls the size of the directory index cache and the number of buffers used on a cachewide basis. Also, `ACP_DINDXCACHE` builds a temporary index into the directory file, thereby reducing search time and directory header lookup operations.

#### **ACP\_DIRCACHE (A,D,F)**

`ACP_DIRCACHE` sets the number of pages for caching directory blocks. Too small a value causes excessive XQP I/O operations, while too large a value causes excessive physical memory to be consumed by the directory data block cache.

#### **ACP\_EXTCACHE (D,F)**

`ACP_EXTCACHE` sets the number of entries in the extent cache. Each entry points to one contiguous area of free space on disk. A specification of 0 means no cache. Too small a value causes excessive XQP I/O operations, while too large a value causes excessive physical memory to be consumed by the extent cache.

#### **ACP\_EXTLIMIT (D)**

`ACP_EXTLIMIT` specifies the maximum amount of free space to which the extent cache can point, expressed in thousandths of the currently available free blocks on the disk. For example, if available free space on the disk is 20,000 blocks, a specification of 10 limits the extent cache to 200 blocks.

The computed, installed value is usually adequate. Users with four or more OpenVMS Cluster node systems might want to adjust this parameter.

#### **ACP\_FIDCACHE (D,F)**

`ACP_FIDCACHE` sets the number of file identification slots cached. A specification of 1 means no cache. Too small a value causes excessive XQP I/O operations, while too large a value causes excessive physical memory to be consumed by the FID caches.

#### **ACP\_HDRCACHE (A,D,F)**

ACP\_HDRCACHE sets the number of pages for caching file header blocks. Too small a value causes excessive XQP I/O operations, while too large a value causes excessive physical memory to be consumed by the file header caches.

#### **ACP\_MAPCACHE (A,D,F)**

ACP\_MAPCACHE sets the number of pages for caching index file bitmap blocks. Too small a value causes excessive XQP I/O operations, while too large a value causes excessive physical memory to be consumed by the bitmap cache.

#### **ACP\_MAXREAD (D)**

ACP\_MAXREAD sets the maximum number of directory blocks read in one I/O operation.

#### **ACP\_MULTIPLE (A,D)**

ACP\_MULTIPLE enables (1) or disables (0) the default creation of a separate disk XQP cache for each volume mounted on a different device type. Prior to Version 4.0, a separate ACP process was created for each device type if this parameter was enabled. Because ACP operations are now handled by the per process XQP, such separate processes are no longer created. In general, having multiple caches is unnecessary. One large cache is more efficient than several small ones. ACP\_MULTIPLE can be overridden on an individual-volume basis with the DCL command MOUNT.

#### **ACP\_QUOCACHE (A,D,F)**

ACP\_QUOCACHE sets the number of quota file entries cached. A specification of 0 means no cache. Too small a value causes excessive XQP I/O operations, while too large a value causes excessive physical memory to be consumed by the quota caches.

#### **ACP\_REBLDSYSD**

ACP\_REBLDSYSD specifies whether the system disk should be rebuilt if it was improperly dismounted with extent caching, file number caching, or disk quota caching enabled. The ACP\_REBLDSYSD default value (1) ensures that the system disk is rebuilt. Setting the value to 0 means the disk is not rebuilt.

Depending on the amount of caching enabled on the volume before it was dismounted, the rebuild operation may consume a considerable amount of time. Setting the value of ACP\_REBLDSYSD to 0 specifies that the disk should be returned to active service immediately. If you set ACP\_REBLDSYSD to 0, you can enter the DCL command SET VOLUME/REBUILD at any time to rebuild the disk.

#### **ACP\_SHARE (D)**

ACP\_SHARE enables (0) or disables (1) the creation of a global section for the first ACP used, enabling succeeding ACPs to share its code. This parameter should be set to 0 when ACP\_MULTIPLE is on.

#### **ACP\_SWAPFLGS (A,D)**

ACP\_SWAPFLGS enables or disables swap through the value of a 4-bit number for the following four classes of ACPs:

## System Parameters

### D.2 Parameter Descriptions

| Bit | Class of ACP                  |
|-----|-------------------------------|
| 0   | Disks mounted by MOUNT/SYSTEM |
| 1   | Disks mounted by MOUNT/GROUP  |
| 2   | Private disks                 |
| 3   | Magnetic tape ACP             |

If the value of the bit is 1, the corresponding class of ACPs can be swapped. The value of decimal 15 (hexadecimal F—all bits on) enables swap for all classes of ACP. A value of decimal 14 disables swap for ACPs for volumes mounted with the /SYSTEM qualifier but leaves swap enabled for all other ACPs. Note that one has only disk ACPs present if they are specifically requested at mount time or if a Files-11 On-Disk Structure Level 1 disk is mounted. In general, only bit 3 is significant because usually no file ACPs exist.

#### **ACP\_SYSACC (A,D)**

ACP\_SYSACC sets the number of directory file control blocks (FCBs) that are cached for disks mounted with the /SYSTEM qualifier. Each directory FCB contains a 16-byte array containing the first letter of the last entry in each block of the directory (or group of blocks if the directory exceeds 16 blocks). Since entries in a directory are alphabetical, the cached FCB provides quick access to a required directory block. This parameter value should be roughly equivalent to the number of directories that are in use concurrently on each system volume. It might be overridden on a per-volume basis with the /ACCESSED qualifier to the DCL command MOUNT. The value should be kept low in systems with small physical memory and little file activity, because the FCBs require a significant amount of space in the nonpaged dynamic pool.

Too small a value causes excessive XQP I/O operations, while too large a value causes excessive physical memory to be consumed by the FCB caches.

#### **ACP\_WINDOW (D)**

ACP\_WINDOW sets the default number of window pointers to be allocated in a window for a default file access, for disks mounted with the /SYSTEM qualifier.

#### **ACP\_WORKSET (D)**

ACP\_WORKSET sets the default size of a working set for an ACP. A specification of 0 permits the ACP to calculate the size. This value should be nonzero only on small systems where memory is tight. Too small a value causes excessive ACP page, while too large a value causes excessive physical memory to be consumed by the ACP. Note that this parameter has no effect on the per-process XQP.

#### **ACP\_WRITEBACK (D)**

ACP\_WRITEBACK is a dynamic system parameter that controls whether deferred writes to file headers are enabled. The default value is 1, which enables deferred writes to file headers. To disable the feature, set ACP\_WRITEBACK to 0.

This system parameter affects only applications like PATHWORKS that can request deferred writes to file headers. Note that the deferred write feature is not available on Files-11 ODS-1 volumes.

#### **ACP\_XQP\_RES**

ACP\_XQP\_RES controls whether the XQP is currently in memory. The default value (1) specifies that the XQP is permanently in memory. Change the default only on restricted memory systems with a small number of users and little or



## System Parameters

### D.2 Parameter Descriptions

no file activity that requires XQP intervention. Such activity includes file opens, closes, directory lookups, and window turns.

#### **AFFINITY\_SKIP**

**AFFINITY\_SKIP** controls the breaking of implicit affinity. The value indicates the number of times a process is skipped before being moved.

This special parameter is used by HP and is subject to change. Do not change this parameter unless HP recommends that you do so.

#### **AFFINITY\_TIME**

**AFFINITY\_TIME** controls the breaking of implicit affinity. The value indicates how long a process remains on the compute queue.

This special parameter is used by HP and is subject to change. Do not change this parameter unless HP recommends that you do so.

#### **ALLOCLASS**

**ALLOCLASS** determines the device allocation class for the system. The device allocation class is used to derive a common lock resource name for multiple access paths to the same device.

#### **ARB\_SUPPORT (D)**

(Alpha and Integrity servers) The Access Rights Block (ARB) compatibility option, the **ARB\_SUPPORT** system parameter, is provided specifically to support products that have not yet been updated to use the new per-thread security Persona Security Block (PSB) data structure instead of the ARB. Changing the value of **ARB\_SUPPORT** from 2 or 3 (the default) to any other value can affect the operation of these products.

---

#### **Note**

---

HP recommends that all Version 7.3-1 systems have the **ARB\_SUPPORT** parameter set to 3 (the default). Do not change the **ARB\_SUPPORT** parameter to any other value until all products dependent on the ARB and associated structures have been modified for the new environment.

---

The following table describes **ARB\_SUPPORT** parameters:

| <b>ARB_SUPPORT<br/>Parameter</b> | <b>Value</b>   | <b>Behavior</b>   |
|----------------------------------|----------------|---|
| ISS\$C_ARB_NONE                  | 0              | The obsolete kernel data cells are not maintained by the system. Fields are initialized to zero (or set to invalid pointers) at process creation. |
| ISS\$C_ARB_CLEAR                 | 1              | The obsolete kernel data cells are cleared (or set to invalid pointers) when the code would have set up values for backward compatibility.        |
| ISS\$C_ARB_READ_ONLY             | 2              | The obsolete cells are updated with corresponding security information stored in the current PSB when a \$PERSONA_ASSUME is issued.               |
| ISS\$C_ARB_FULL                  | 3<br>(default) | Data is moved from the obsolete cells to the currently active PSB on any security-based operation.  |

## System Parameters

### D.2 Parameter Descriptions

#### **AUTO\_DLIGHT\_SAV (D)**

AUTO\_DLIGHT\_SAV is set to either 1 or 0. The default is 0.

If AUTO\_DLIGHT\_SAV is set to 1, OpenVMS automatically makes the change to and from daylight saving time.

#### **AWSMIN (D)**

On Alpha and Integrity servers, AWSMIN establishes the lowest number of pagelets to which a working set limit can be decreased by automatic adjustment of the working set.

#### **AWSTIME (D)**

AWSTIME specifies the minimum amount of processor time that must elapse for the system to collect a significant sample of a working set's page fault rate. The time is expressed in units of 10 milliseconds. The default value of 5, for example, is 50 milliseconds.

Some application configurations that have a large number of memory-intensive processes may benefit if the value is reduced. The value can be as low as 4.

AWSTIME expiration is checked only at quantum end. Reducing its value and not reducing QUANTUM effectively sets the value of AWSTIME equal to the value of QUANTUM.

#### **BALSETCNT (A,G,D,M)**

BALSETCNT sets the number of balance set slots in the system page table. Each memory-resident working set requires one balance set slot.

You can monitor the active system with the DCL command SHOW MEMORY or the MONITOR PROCESSES command of the Monitor utility to determine the actual maximum number of working sets in memory. If this number is significantly lower than the value of BALSETCNT, this parameter value could be lowered. If all balance set slots are being used, raise the value of BALSETCNT.

Never set BALSETCNT to a value higher than 2 less than MAXPROCESSCNT. If physical memory is a significant system constraint, consider lowering this value even further. However, if your system runs with a number of processes nearly equal to MAXPROCESSCNT, lowering BALSETCNT forces swapping to occur, which can affect system performance.

BALSETCNT is no longer a strict setting of the number of processes that might be resident in memory. The swapper tries to reduce the number of resident processes down to BALSETCNT. However, if the total number of active processes and processes that have disabled swapping exceeds BALSETCNT, the swapper does not force processes out of memory just to meet the BALSETCNT setting.

#### **BORROWLIM (A,D,M)**

BORROWLIM defines the minimum number of pages required on the free-page list before the system permits process growth beyond the working set quota (WSQUOTA) for the process. This parameter should always be greater than FREELIM.

This parameter allows a process to grow beyond the value set by the working set quota (WSQUOTA) to the working set quota extent (WSEXTENT) on a system that has a substantial memory on the free-page list. This automatic working set adjustment also depends upon the values of parameters WSINC, PFRATH, and AWSTIME.

## System Parameters

### D.2 Parameter Descriptions

Working set growth attempts to alleviate heavy page faulting. To make use of this growth, you must also set the user's WSEXTENT authorization quota to a larger number than the WSQUOTA value.

#### **BREAKPOINTS (D)**

If XDELTA is loaded, BREAKPOINTS enables additional built-in calls for XDELTA during the boot sequence. The breakpoints that are enabled may change from release to release of OpenVMS.

This special parameter is used by HP and is subject to change. Do not change this parameter unless HP recommends that you do so.

#### **BUGCHECKFATAL (D)**

BUGCHECKFATAL enables or disables the conversion of nonfatal bugchecks into fatal bugchecks. The system must be rebooted on a fatal bugcheck. A nonfatal bugcheck places an entry only in the error log and deletes the corresponding process.

This parameter should normally be OFF (0); you should set it ON (1) only when the executive is being debugged.

Setting the SYSTEM\_CHECK parameter to 1 has the effect of setting BUGCHECKFATAL to ON (1).

#### **BUGREBOOT (D)**

BUGREBOOT enables or disables automatic rebooting of the system if a fatal bugcheck occurs. This parameter should normally be on (1); set it off (0) only when the executive is being debugged.

#### **CHANNELCNT**

CHANNELCNT specifies the maximum number of I/O channels available to processes and to the system. The FILLM quota can be used to reduce the maximum number of I/O channels for a process. A process with a FILLM quota larger than CHANNELCNT is nevertheless limited to the maximum number of I/O channels specified by CHANNELCNT.

#### **CLASS\_PROT (D)**

CLASS\_PROT performs the nondiscretionary classification checks. CLASS\_PROT is also checked by XQP to determine if a classification block should be added to the header of any created files.

#### **CLISYMTBL (D)**

CLISYMTBL sets the size of the command interpreter symbol table, which controls the number of DCL symbols that can be created.

#### **CLUSTER\_CREDITS**

CLUSTER\_CREDITS specifies the number of per-connection buffers a node allocates to receiving VMS\$VAXcluster communications.

If the SHOW CLUSTER command displays a high number of credit waits for the VMS\$VAXcluster connection, you might consider increasing the value of CLUSTER\_CREDITS on the other node. However, in large cluster configurations, setting this value unnecessarily high consumes a large quantity of nonpaged pool. Each receive buffer is at least SCSMAXMSG bytes in size but might be substantially larger depending on the underlying transport.

It is not required for all nodes in the cluster to have the same value for CLUSTER\_CREDITS.

## System Parameters

### D.2 Parameter Descriptions

The default value is currently 32. Unless a system has very constrained memory available, HP recommends that these values not be increased.

#### **CONCEAL\_DEVICES**

CONCEAL\_DEVICES enables or disables the use of concealed devices. By default, this parameter is set to enable concealed devices (1).

This special parameter is used by HP and is subject to change. Do not change this parameter unless HP recommends that you do so.

#### **CPU\_POWER\_MGMT**

On Integrity servers, a CPU can be placed in “low-power mode” when it is idle. This minimizes power consumption, thereby reducing energy costs for the system. Beginning in Version 8.2-1, OpenVMS Integrity servers supports this feature based on the settings of two system parameters: CPU\_POWER\_MGMT and CPU\_POWER\_THRSH.

A value of 1 for CPU\_POWER\_MGMT means on (the default); a value of 0 means off. Whenever the CPU\_POWER\_THRSH parameter value is exceeded, the operating system places an Integrity processor in low-power mode if it is idle. OpenVMS Integrity servers does this only if CPU\_POWER\_MGMT is on. A CPU returns to normal power when it receives an interrupt.

#### **CPU\_POWER\_THRSH**

On Integrity servers, CPU\_POWER\_THRSH is a parameter expressed as a percentage. OpenVMS Integrity servers monitors how active each CPU is over a fixed time period. If CPU\_POWER\_MGMT is on and a CPU is idle for a period of time indicated by CPU\_POWER\_THRSH, the CPU is placed in a low-power mode if it is idle. A CPU returns to normal power when it receives an interrupt.

For systems supporting real-time operations that require quick response time, HP recommends that this feature be turned off. Use of this feature can result in a small performance degradation.

For more information, see the *Intel IA-64 Architecture Software Developer's Manual, Volume 2: IA-64 System Architecture*.

See also the CPU\_POWER\_MGMT parameter.

#### **CRD\_CONTROL**

This special parameter is used by HP and is subject to change. Do not change this parameter unless HP recommends that you do so. On Alpha and Integrity servers, CRD\_CONTROL can be used to expand the function defined by CRDENABLE.

CRD\_CONTROL is a bit mask for corrected read data (CRD) soft error control flags. These flags control the use of CRDERROUTINES.

On Alpha and Integrity servers, the following bits are defined:

| Bit | Description  |
|-----|--|
| 0   | Enables CRD processing for all systems.                                    |
| 1   | Enables scrubbing (rewriting) of the memory location that induced the CRD. |
| 2   | Enables page replacement of the pages that exhibit repeated CRD errors.    |

## System Parameters

### D.2 Parameter Descriptions

| Bit   | Description   |
|-------|---|
| 3     | Forces all memory pages to be included in the PFN database. On systems that contain more than 512 megabytes of memory, all memory is mapped by the PFN database by default. This bit allows the mapping to occur on systems with less than 512 megabytes of memory. |
| 4     | Enables extended CRD handling, if available.  |
| 5     | Enables loading of driver and process for handling server management events. Platform-specific code usually sets this bit if the required hardware and firmware support are available.  |
| 6     | Disables CRD throttling.  |
| 7     | Disables System Event Log (SEL) polling.  |
| 16-31 | Reserved for platform-specific error-handling control.  |

On Alpha and Integrity servers, the default setting is 22, which enables scrubbing, page replacement, and extended CRD handling.

#### **CRDENABLE**

(Alpha and Integrity servers) **CRDENABLE** enables or disables detection and logging of memory-corrected read data (ECC) errors. This parameter should normally be set to (1).

Beginning with OpenVMS Version 7.2, **CRD\_CONTROL** can expand the function of **CRDENABLE**. (See **CRD\_CONTROL**.)

#### **CTLIMGLIM**

**CTLIMGLIM** specifies the size of the default image I/O segment; that is channel table and initial buffer pool for image-related file and RMS I/O.

This special parameter is used by HP and is subject to change. Do not change this parameter unless HP recommends that you do so.

#### **CTLPAGES (A)**

**CTLPAGES** specifies the size of P1 pool. **CTLPAGES** is automatically changed only when the process logical name table, DCL symbols, or some layered products require an increase in the size of the P1 pool area.

This special parameter is used by HP and is subject to change. Do not change this parameter unless HP recommends that you do so.

#### **CWCREPRC\_ENABLE**

**CWCREPRC\_ENABLE** controls whether an unprivileged user can create a process on another OpenVMS Cluster node. The default value of 1 allows an unprivileged user to create a detached process with the same UIC on another node. A value of 0 requires that a user have **DETACH** or **CMKRNL** privilege to create a process on another node.

#### **DBGTK\_SCRATCH**

(Alpha and Integrity servers) **DBGTK\_SCRATCH** specifies how many pages of memory are allocated for the remote debugger. This memory is allocated only if remote debugging is enabled with the 8000 boot flag. Normally, the default value is adequate, but if the remote debugger issues an error message, you should increase this value. See *Writing OpenVMS Alpha Device Drivers in C* (Margie Sherlock and Lenny S. Szubowicz, Digital Press, 1996).

## System Parameters

### D.2 Parameter Descriptions

#### DCL\_CTLFLAGS

DCL\_CTLFLAGS is a bit mask that alters default behavior for certain DCL-related functions on a systemwide basis. However, the default values satisfy the needs of most systems.

Bits 0 and 2 control the formulation of system-generated process names for processes created using the SPAWN command or LIB\$SPAWN library routine. They are provided for compatibility with behavior of prior OpenVMS versions. Note that you can eliminate the use of system-generated names by supplying your own process names.

Bit 1 controls the token size used by DCL.

Bit 3 controls the maximum number input parameters to command procedure.

Bit 4 controls the the maximum length for an user name, for which OpenVMS mail forwarding address is set.

DCL\_CTLFLAGS bits are described in the following table.

| Bit   | Description  |
|-------|--|
| Bit 0 | <p>If clear (the default), the numeric portion of a system-generated spawned process name is generated randomly. If set, the numeric portion is generated sequentially starting with sequence number 1.</p> <p>The option of sequential generation is provided for compatibility with OpenVMS versions prior to Version 7.3-1. However, this choice can be very expensive in performance terms because of the mechanism for finding the next available process name. This mechanism attempts to create all process names beginning with sequence number 1 until it finds one that is unused.</p> <p>Random generation is the preferred choice because it results in a very high probability of finding a unique name on the first try.</p>             |
| Bit 1 | <p>Controls the token size used by DCL. If clear (the default), this bit instructs DCL to use the traditional token size. A token cannot exceed 255 characters. If this bit is set, extended tokens are used. Extended tokens are 4000 characters.</p> <p>Note that if you turn on extended tokens, file specifications can exceed 255 characters, which might require larger structures for parsing file specifications.</p>  |
| Bit 2 | <p>If clear (the default), the numeric portion of a system-generated spawned process name has a maximum value of 65535. If set, the numeric portion of the name has a maximum value of 255.</p> <p>The option of a maximum of 255 is provided for compatibility with OpenVMS versions prior to Version 8.3, when it was the only choice. The larger maximum allows many more unique spawned process names for a given process. For this reason, it is the preferred choice. However, the larger maximum uses two additional characters from the process name, which might make it more difficult to identify users uniquely by looking at their spawned process names. If this is an issue on your system, setting bit 2 might be a better choice.</p> |
| Bit 3 | <p>If clear (the default), command procedure supports the default eight optional parameters (that is, (P1,P2,...P8)). If set, command procedure supports up to sixteen optional parameters (that is, (P1,P2,...P16)). This is also applicable when using the CALL command to transfer control to a subroutine.</p>   |



## System Parameters

### D.2 Parameter Descriptions

| Bit   | Description   |
|-------|---|
| Bit 4 | <p>This bit controls the the maximum length for an user name, for which OpenVMS mail forwarding address is set. If clear (the default), user name string length is set to a maximum length of 31 characters. If set, user name string length is set to a maximum of 255 characters.</p> <p>Note: Once this bit is set, user name length is set to maximum of 255 characters. Even if this bit is cleared, the behavior remains unchanged, that is, supports user name length of 255 characters, but there is no way to reset it to 31 characters.</p> |

#### **DEADLOCK\_WAIT (D)**

DEADLOCK\_WAIT defines the number of seconds that a lock request must wait before the system initiates a deadlock search on behalf of that lock. Setting DEADLOCK\_WAIT to zero disables deadlock checking. Setting DEADLOCK\_WAIT to a value greater than zero and less than the default setting provides faster detection of deadlocks but requires more CPU usage.

The DEADLOCK\_WAIT value is expressed in seconds; therefore, the smallest value you can set is 1 second. Beginning in HP OpenVMS Version 8.3, a subsecond deadlock wait time, which is set in the system service \$SET\_PROCESS\_PROPERTIESW item code \$PPROP\$C\_DEADLOCK\_WAIT, overrides DEADLOCK\_WAIT. For more information, see the \$SET\_PROCESS\_PROPERTIESW system service in *HP OpenVMS System Services Reference Manual*.

#### **DEFGID**

Default POSIX GID used internally by OpenVMS.

#### **DEFMBXBUFQUO (D)**

DEFMBXBUFQUO sets the default for the mailbox buffer quota size in bytes when this value is not specified in a Create Mailbox (\$CREMBX) system service call.

#### **DEFMBXMXMSG (D)**

DEFMBXMXMSG sets the default for the mailbox maximum message size in bytes when this value is not specified in a Create Mailbox (\$CREMBX) system service call.

#### **DEFPRI (D)**

DEFPRI sets the base default priority for processes.

#### **DEFQUEPRI (D)**

DEFQUEPRI establishes the scheduling priority for jobs entered in batch and output (printer, server, and terminal) queues when no explicit scheduling priority is specified by the submitter. The value of this parameter can range from 0 to 255; the default value is 100.

The value of DEFQUEPRI should be less than or equal to MAXQUEPRI.

---

#### **Note**

---

DEFQUEPRI refers to relative queue scheduling priority, not the execution priority of the job.

---

## System Parameters

### D.2 Parameter Descriptions

#### DEFUID

Default POSIX UID used internally by OpenVMS.

#### DELPRC\_EXIT (D)

DELPRC\_EXIT can be used to control \$DELPRC system service options that call exit handlers prior to final cleanup and deletion of a process. The following table describes these options:

| Option      | Description  |
|-------------|--|
| 0           | Disable the exit handler functionality with \$DELPRC.      |
| 4           | Execute kernel mode exit handlers.                         |
| 5 (default) | Execute exec and more privileged mode exit handlers.       |
| 6           | Execute supervisor and more privileged mode exit handlers. |
| 7           | Execute user and more privileged mode exit handlers.       |

#### DEVICE\_NAMING

(Alpha and Integrity servers) DEVICE\_NAMING is a bit mask indicating whether port allocation classes are used in forming SCSI device names.

Following is the bit definition:

| Bit | Definition  |
|-----|---|
| 0   | If 1, enable new naming.                          |
| 1   | Must be 0. This bit is reserved for use by HP.    |
| 2   | If 1, cloned device unit numbers wrap after 9999. |

For more information about port allocation classes, see *HP OpenVMS Cluster Systems*.

#### DISABLE\_UPCALLS (D)

DISABLE\_UPCALLS is primarily a debugging aid. It allows the system manager to disable threads upcalls of specific types for the entire system. The value is a bit mask, with the bits corresponding to the upcall types. The upcall types are defined in the definition macro \$TMCDEF.

This special parameter is used by HP and is subject to change. Do not change this parameter unless HP recommends that you do so.

#### DISK\_QUORUM (D)

The DISK\_QUORUM parameter is the name of an optional quorum disk in ASCII. ASCII spaces indicate that no quorum disk is being used.

#### DISMOUMSG (D)

DISMOUMSG controls whether the messages that log volume dismounts appear on the operator's terminal and in the operator's log. The default value of 0 disables reporting of these messages.

#### DNVOSI1

DNVOSI1 is reserved to DECnet-Plus for OpenVMS. This special parameter is used by HP and is subject to change. Do not change this parameter unless HP recommends that you do so.



**DORMANTWAIT (D)**

DORMANTWAIT specifies, in seconds, the amount of time that can elapse without a significant event before the system treats a low-priority computable process as a DORMANT process for scheduling purposes. (A low-priority process is a non real-time process whose current priority is equal to or less than the value specified by the system parameter DEFPRI [default=4].) After SUSP (suspended) processes, DORMANT processes are the most likely candidates for memory reclamation by the swapper.

Increasing the value of DORMANTWAIT can increase the interval that a low priority process blocks a high priority process if that low priority process is holding a lock or resource that the higher priority process is waiting for.

**DR\_UNIT\_BASE (G)**

(Alpha only) DR\_UNIT\_BASE specifies the base value from which unit numbers for DR devices (DIGITAL StorageWorks RAID Array 200 Family logical RAID drives) are counted.

DR\_UNIT\_BASE provides a way for unique RAID device numbers to be generated. DR devices are numbered starting with the value of DR\_UNIT\_BASE and then counting from there. For example, setting DR\_UNIT\_BASE to 10 produces device names such as \$1\$DRA10, \$1\$DRA11, and so on.

Setting DR\_UNIT\_BASE to appropriate, nonoverlapping values on all cluster members that share the same (nonzero) allocation class ensures that no two RAID devices are given the same name.

**DUMPBUG**

DUMPBUG enables (1) or disables (0) the writing of error log buffers and memory contents to SYS\$SYSTEM:SYSDUMP.DMP when a fatal bugcheck occurs. This parameter should be off (0) only when the executive is being debugged.

**DUMPSTYLE (A,D)**

DUMPSTYLE specifies the method of writing system dumps.

DUMPSTYLE is a 32-bit mask, with the following bits defined. Each bit can be set independently. The value of the system parameter is the sum of the values of the bits that have been set. Remaining or undefined values are reserved for HP use only.

| Bit | Mask     | Description  |
|-----|----------|--|
| 0   | 00000001 | 0 = Full dump (SYSGEN default). The entire contents of physical memory are written to the dump file.   |
|     |          | 1 = Selective dump. The contents of memory are written to the dump file selectively to maximize the usefulness of the dump file while conserving disk space. |
| 1   | 00000002 | 0 = Minimal console output.  |
|     |          | 1 = Full console output (includes stack dump, register contents, and so on).   |
| 2   | 00000004 | 0 = Dump to system disk.   |

## System Parameters

### D.2 Parameter Descriptions

| Bit  | Mask     | Description  |
|--|----------|--|
|  |          | 1 = Dump off system disk (DOSD) to an alternate disk. (See the <i>HP OpenVMS System Manager's Manual</i> for details.) |
| 3 (Alpha and Integrity servers) <sup>1</sup> | 00000008 | 0 = Do not compress.   |
|  |          | 1 = Compress. (See note below.)  |
| 4 (Alpha and Integrity servers) <sup>2</sup> | 00000010 | 0 = Dump shared memory.  |
|  |          | 1 = Do not dump shared memory. (See note below.)   |
| 5 - 14                                       |          | Reserved for HP use only.  |
| 15 (VAX only) <sup>3</sup>                   | 00008000 | 0 = Disable use of bits 16 - 27.   |
|  |          | 1 = Enable use of bits 16 - 27.  |
| 16 - 27 (VAX only) <sup>2</sup>              | 0FFF0000 | Range of DOSD unit numbers.  |
| 28 - 31                                      |          | Reserved for HP use only.  |

<sup>1</sup>VAX systems do not support dump compression.

<sup>2</sup>VAX systems do not support shared memory.

<sup>3</sup>Specific to VAX 7000s.

If you plan to enable the Volume Shadowing minimerge feature on an Alpha or Integrity servers disk, be sure to specify DOSD to an alternate disk.

---

#### Note

---

On Alpha and Integrity servers, you can save space on the system disk and, in the event of a crash, save time recording the system memory, by using the OpenVMS Alpha and Integrity servers dump compression feature. Unless you override the default AUTOGEN calculations (by setting DUMPSTYLE in MODPARAMS.DAT), AUTOGEN uses the following algorithm:

- On a system with less than 128 MB of memory, the system sets the DUMPSTYLE to 1 (a raw selective dump) and sizes the dump file appropriately.
  - On a system with 128 MB of memory or greater, the system sets the DUMPSTYLE to 9 (a compressed selective dump), and creates the dump file at two-thirds the value of the corresponding raw dump.
- 

#### Examples:

The mask of 00000006 directs the system to send a full dump, with full console output, off the system disk (to the alternate disk).

For a VAX 7000, a mask of 00098006 directs the system to send a full dump with full console output to the DOSD whose unit number is 9.

On Alpha and Integrity servers, the mask of 00000009 directs the system to compress a selective dump with minimal console output.

## System Parameters

### D.2 Parameter Descriptions

#### **ERLBUFFERPAG\_S2 (A on Alpha and Integrity servers)**

ERLBUFFERPAG\_S2 specifies the amount of S2 space memory to allocate for each S2 space error log buffer requested by the ERRORLOGBUFF\_S2 parameter.

If you increase ERLBUFFERPAG\_S2, you must either run AUTOGEN or manually increase the size of both the system dump file and the error log dump file.

#### **ERLBUFFERPAGES (A on Alpha and Integrity servers)**

ERLBUFFERPAGES specifies the amount of S0 space memory to allocate for each S0 space error log buffer requested by the ERRORLOGBUFFERS parameter.

#### **ERRORLOGBUFF\_S2 (A on Alpha and Integrity servers)**

ERRORLOGBUFF\_S2 specifies the number of S2 space error log buffers reserved for system error log entries. Each buffer is ERLBUFFERPAG\_S2 in length. If ERRORLOGBUFF\_S2 is too low, messages might not be written to the error log file. If it is too high, the buffers can consume unnecessary physical pages.

If you increase ERRORLOGBUFF\_S2, you must either run AUTOGEN or manually increase the size of both the system dump file and the error log dump file.

#### **ERRORLOGBUFFERS (A on Alpha and Integrity servers)**

ERRORLOGBUFFERS specifies the number of S0 space error log buffers reserved for system error log entries. Each buffer is ERLBUFFERPAGES in length. If ERRORLOGBUFFERS is too low, messages might not be written to the error log file. If it is too high, the buffers can consume unnecessary physical pages.

#### **EXECSTACKPAGES (D)**

(Alpha and Integrity servers) EXECSTACKPAGES controls the number of pages allocated for each RMS exec stack.

#### **EXPECTED\_VOTES (A)**

EXPECTED\_VOTES specifies the maximum number of votes that can be present in a cluster at any given time. Set it to a value that is equal to the sum of the vote parameters of all cluster members, plus any votes that are contributed by the quorum disk. This value is used to automatically derive the number of votes that must be present for the cluster to function (quorum).

#### **EXTRACPU (D)**

EXTRACPU sets the time, in units of 10 ms, allotted to each of a process's exit handlers (for each access mode) after the process times out (that is, reaches its CPU time limit).

#### **FAST\_PATH**

(Alpha and Integrity servers) FAST\_PATH is a static system parameter that enables (1) or disables (0) the Fast Path performance features for all Fast Path-capable ports.

Starting in OpenVMS Version 7.2, FAST\_PATH is enabled by default. In Versions 7.0 and 7.1, FAST\_PATH was disabled by default.

For additional information, see FAST\_PATH\_PORTS.

#### **FAST\_PATH\_PORTS**

(Alpha and Integrity servers) FAST\_PATH\_PORTS is a static parameter that deactivates Fast Path for specific drivers.

## System Parameters

### D.2 Parameter Descriptions

FAST\_PATH\_PORTS is a 32-bit mask, with a bit assigned for each Fast Path port driver. The following table describes the bit values:

| Bit Value | Description  |
|-----------|--|
| 1         | Indicates that Fast Path is disabled for ports serviced by the corresponding driver.     |
| 0         | Indicates that Fast Path is not disabled for ports serviced by the corresponding driver. |

Beginning in OpenVMS Version 7.3-1, values of specific bit positions are those described in the following table:

| Bit Position | Description   |
|--------------|---|
| 0            | Controls Fast Path for PKQDRIVER (for parallel SCSI).   |
| 1            | Controls Fast Path for FGEDRIVER (for Emulex LP7000, LP8000, LP9002, LP9802, LP10000 FibreChannel). |
| 2            | Controls Fast Path for PKADRIVER (for Adaptec AIC-78xx Ultra3 SCSI).                                |
| 3            | Controls Fast Path for PEDRIVER (for LAN).  |
| 4            | Controls Fast Path for PKRDRIVER (for SMART Array 5300).  |
| 5            | Controls Fast Path for PKMDRIVER, the LSI Logic LSI53C1030 SCSI port driver.                        |
| 6            | Controls Fast Path for PGQDRIVER, the Qlogic ISP23xx FibreChannel port driver.                      |

Currently, the default setting for FAST\_PATH\_PORTS is 0, which means that Fast Path is enabled for all drivers that appear in the table.

In addition, note the following:

- CI drivers are not controlled by FAST\_PATH\_PORTS. Fast Path for CI is enabled and disabled exclusively by the FAST\_PATH system parameter.
- FAST\_PATH\_PORTS is relevant only if the FAST\_PATH system parameter is enabled (equal to 1). Setting FAST\_PATH to zero has the same effect as setting all the bits in FAST\_PATH\_PORTS to 1.

For additional information, see FAST\_PATH. For an explanation of how to set the bits, see the *OpenVMS I/O User's Reference Manual*.

#### **FREEGOAL (A,D,M)**

FREEGOAL establishes the number of pages that you want to reestablish on the free-page list following a system memory shortage. Memory shortages occur when the system drops below the minimum number of pages required on the free-page list (FREELIM). The value of FREEGOAL must always be greater than or equal to the value of FREELIM.

#### **FREELIM (A,M)**

FREELIM sets the minimum number of pages that must be on the free-page list.

The system writes pages from the modified-page list, swaps out working sets, or reduces the size of the working sets to maintain the minimum count.

## System Parameters

### D.2 Parameter Descriptions

While the larger free-page list generally means less page I/O, it also means less space for the balance set, which tends to result in more swap I/O. You can monitor the size of the free-page list, the amount of page, and the amount of swap with the MONITOR IO command of the Monitor utility.

#### **GALAXY**

(Alpha Galaxy platforms only) The GALAXY parameter sets memory sharing.

Specify one of the following:

| Value | Description  |
|-------|--|
| 0     | The default. Do not participate in a memory sharing. |
| 1     | Participate in a memory sharing.                     |

When you set GALAXY to 1 in a hard partition, OpenVMS instances will share memory between soft partitions within that hard partition. (You can run more than two soft partitions in a hard partition, and you might not want to share memory among all of them.) Note that GALAXY specifies only if a node uses shared memory. You do not need to use the parameter to run multiple cooperative instances of OpenVMS; you do this by console setup of the configuration tree that you want.

#### **GBLPAGES (A,D,F,G,M)**

GBLPAGES sets the number of global page table entries allocated at bootstrap time. Each global section requires 1 global page table entry per section page, plus 2 entries, with the total rounded up to an even number.

Users with CMKRNL privilege can change this parameter on a running system. Increasing the value of this parameter allows the global page table to expand, on demand, up to the maximum size.

The default value is sufficient for the images normally installed as shared in the system startup command procedures. Once the system is running and all global sections are created, you can examine the actual requirements with the /GLOBAL qualifier of the Install utility (INSTALL) and reduce the value of GBLPAGES accordingly. However, do not set the value of this parameter too low, because the page table entries use little permanently resident memory. If you plan to install many user images as shared, or if user programs are likely to create many global sections, you must increase the value of this parameter.

#### **GBLPAGFIL (A,D)**

GBLPAGFIL defines the maximum number of systemwide pages allowed for global page-file sections (scratch global sections that can be used without being mapped to a file). These global page-file sections can be temporary, permanent, system, or group, and are allocated from the page file specified in the system process header at bootstrap time. When you allow pages for global page-file sections, you must increase the size of the page file accordingly. Users with CMKRNL privilege can change this parameter value on a running system.

Global page-file sections are created with the Create and Map Section system services (\$CREATE\_GPFILE, \$CRMPSC, and \$CRMPSC\_GPFILE\_64) without an explicit disk file. These sections are used for the RMS global buffers required for shared files. Users of shared files should note that global page-file sections cause both the global page table and the default system page file (PAGEFILE.SYS) to be used. If the value of GBLPAGFIL is too small, \$CRMPSC issues an error message when you attempt to create global page-file sections.

## System Parameters

### D.2 Parameter Descriptions

You must have scratch global sections if you use RMS global buffers. Each file using global buffers requires, in the system page file, the file's bucket size multiplied by the number of global buffers for that file. If the file's bucket size varies, as with RMS indexed files, use the maximum bucket size. For shared sequential files, use the multiblock count of the first stream to perform the \$CONNECT service in place of the file's bucket size.

The default value for this parameter is adequate for most systems. However, if your site uses RMS global buffering to a significant extent, you may need to raise the value of GBLPAGFIL. Use the /GLOBAL qualifier of the Install utility to examine the number of pages consumed by RMS global buffers. The global sections used by RMS for global buffers have the prefix RMS\$ followed by 8 hexadecimal digits.

Global buffers are enabled with the DCL command SET FILE/GLOBAL\_BUFFERS, which is described in the *HP OpenVMS DCL Dictionary*.

#### **GBLSECTIONS (A,F,G,M)**

GBLSECTIONS sets the number of global section descriptors allocated in the system header at bootstrap time. Each global section requires one descriptor. Each descriptor takes 32 bytes of permanently resident memory.

The default value is sufficient for the images normally installed as shared in the system startup command procedures. Once the system is running and all global sections are created, you can examine the actual requirements with the /GLOBAL qualifier of the Install utility and reduce the value of GBLSECTIONS accordingly. However, the value of this parameter should not be set too low. If you plan to install many user images as shared, or if user programs are likely to create many global sections, you must increase the value of this parameter.

If the value of GBLSECTIONS is too small, you receive a message from the Install utility at system startup time or whenever you install images manually. Note that too large a value for GBLSECTIONS wastes physical memory.

#### **GB\_CACHEALLMAX (D)**

(Alpha and Integrity servers) If a file is connected to RMS with the RMS global buffer DEFAULT option enabled, the number of blocks cached is either a maximum of the GB\_CACHEALLMAX parameter or a percentage of the file, whichever results in a larger global count.

Note that although a maximum cache size of %x7FFFFFFF is supported for an indexed file, sequential and relative file organizations are restricted to a maximum cache size of 32767.

#### **GB\_DEFPERCENT (D)**

(Alpha and Integrity servers) If a file is connected to RMS with the RMS global buffer DEFAULT option enabled, either a percentage (GB\_DEFPERCENT) of the file is cached or up to GB\_CACHEALLMAX blocks of it are cached, whichever results in a larger global buffer count. A percentage greater than 100 percent can be specified for GB\_DEFPERCENT to provide growing room for a file in the global cache.

Note that although a maximum cache size of %x7FFFFFFF is supported for an indexed file, sequential and relative file organizations are restricted to a maximum cache size of 32767.



## System Parameters

### D.2 Parameter Descriptions

#### **GH\_EXEC\_CODE (A,F)**

(Alpha and Integrity servers) GH\_EXEC\_CODE specifies the size in pages of the execlet code granularity hint region.

#### **GH\_EXEC\_DATA (A,F)**

(Alpha and Integrity servers) GH\_EXEC\_DATA specifies the size in pages of the execlet data granularity hint region.

#### **GH\_RES\_CODE (A,F)**

(Alpha and Integrity servers) GH\_RES\_CODE specifies the size in pages of the resident image code granularity hint region.

#### **GH\_RES\_CODE\_S2**

Specifies the size in pages of the resident 64-bit S2 space resident image code granularity hint region.

#### **GH\_RES\_DATA (A,F)**

(Alpha and Integrity servers) GH\_RES\_DATA specifies the size in pages of the resident image data granularity hint region.

If bit 2 of the LOAD\_SYS\_IMAGES parameter is set, the image LDR\$WRAPUP releases all unused pages in the granularity hint region at the the end of system startup. The unused pages of the resident image granularity hint region are either reserved for future use, or given back to the free memory list.

#### **GH\_RSRVPGCNT (F)**

GH\_RSRVPGCNT specifies the number of pages in the resident image code granularity hint region that the Install utility can use after the system has finished booting.

If bit 2 of the LOAD\_SYS\_IMAGES parameter is set, the image LDR\$WRAPUP releases all unused pages in the granularity hint region at the the end of system startup. The unused pages of the resident image granularity hint region are either reserved for future use, or given back to the free memory list.

GH\_RSRVPGCNT specifies the number of pages that LDR\$WRAPUP attempts to leave in the resident image code granularity hint region. If the GH\_RSRVPGCNT number of pages is larger than the unused pages in the granularity hint region, the region is not expanded to accommodate the number of pages requested.

#### **GLX\_INST\_TMO**

(Alpha Galaxy platforms only) GLX\_INST\_TMO is the time (in milliseconds) that an instance in a Galaxy sharing set can fail to increment its timeout value before the other sharing instances presume that the instance failed and remove it from the sharing set.

The default is 20,000 ms (20 seconds).

#### **GLX\_SHM\_REG**

For Alpha Galaxy systems, GLX\_SHM\_REG is the number of shared memory region structures configured into the Galaxy Management Database (GMDB). If set to 0, the default number of shared memory regions are configured.

If the condition value SS\$\_INSF\_SHM\_REG is returned for the \$CRNMPSC\_GDZRO\_64 system service with the flag SEC\$M\_SHM\_REG, the Galaxy shared memory code has run out of internal SHM\_REG data structures. You need to increase the system parameter GLX\_SHM\_REG and reboot all Galaxy instances with this larger parameter value.

## System Parameters

### D.2 Parameter Descriptions

#### **GROWLIM (A,D,M)**

GROWLIM sets the number of pages that the system must have on the free-page list so that a process can add a page to its working set when it is above quota. GROWLIM has no effect if the process is below its working set quota. GROWLIM acts as a fast shutoff to the working set extent mechanism based on the system's free memory.

#### **IEEE\_ADDRESS**

IEEE\_ADDRESS is reserved for HP use only.

#### **IEEE\_ADDRESSH**

IEEE\_ADDRESSH is reserved for HP use only.

#### **IJOBLIM (D)**

IJOBLIM sets the maximum number of interactive jobs that can be on the system concurrently. You can control the maximum number of concurrent interactive users on the system with the DCL command SET LOGINS/INTERACTIVE.

#### **IMGIOCNT**

IMGIOCNT specifies the default number of pages of image I/O address space to be allocated for the image activator if not specified at program link time.

This special parameter is used by HP and is subject to change. Do not change this parameter unless HP recommends that you do so.

#### **IMGREG\_PAGES**

(Alpha and Integrity servers) IMGREG\_PAGES is the number of pages to reserve in P1 space for images to be installed with shareable address data. If IMGREG\_PAGES is set to 0, no images are installed with shared address data. The default is 10,000 pages.

For more information, see the INSTALL section in the *HP OpenVMS System Management Utilities Reference Manual*.

#### **IO\_PRCPU\_BITMAP**

(Alpha and Integrity servers) This parameter is a bitmap representing up to 1024 CPUs. Each bit set in this bitmap indicates that the corresponding CPU is available for use as a Fast Path preferred CPU.

IO\_PRCPU\_BITMAP defaults to all bits set. (CPU 0 through CPU 1023 are all enabled for Fast Path port assignment.)

You might want to disable the primary CPU from serving as a preferred CPU by leaving its bit clear in IO\_PRCPU\_BITMAP, which reserves the primary CPU for non-Fast Path IO operations to use.

To change the value of IO\_PRCPU\_BITMAP in SYSBOOT or SYSGEN, specify a list of individual bits or contiguous groups of bits. For example:

```
SYSGEN> SET IO_PRCPU_BITMAP 0,5,17-21
```

This command sets bits 0, 5, 17, 18, 19, 20, and 21 in the bitmap and clears all other bits.

Changing the value of IO\_PRCPU\_BITMAP causes the FASTPATH\_SERVER process to run the automatic assignment algorithm that spreads Fast Path ports evenly among the new set of usable CPUs.

For additional information, see FAST\_PATH and FAST\_PATH\_PORTS.



## System Parameters

### D.2 Parameter Descriptions

This parameter replaces IO\_PREFER\_CPU.

#### **IOTA**

IOTA specifies the amount of time (in 10-millisecond units) to charge to the current residence quantum for each voluntary wait. The correct value approximates the cost of a disk I/O neglecting wait time.

This special parameter is used by HP and is subject to change. Do not change this parameter unless HP recommends that you do so.

#### **IRPCOUNT (G,M)**

IRPCOUNT sets the number of preallocated intermediate request packets. Each packet requires 160 bytes of permanently resident memory. If IRPCOUNT is too large, physical memory is wasted. If IRPCOUNT is too small, the system increases its value automatically, as needed, to permit proper performance. However, the system cannot increase IRPCOUNT beyond the value of IRPCOUNTV.

Allowing this growth causes a physical memory penalty. If IRPCOUNT is underconfigured, the penalty is 4 percent of physical memory from the configured value to the actual value on the running system.

You can use the DCL command SHOW MEMORY/POOL/FULL to determine IRPCOUNT usage.

#### **IRPCOUNTV (G)**

IRPCOUNTV establishes the upper limit to which IRPCOUNT can be automatically increased by the system.

If this parameter is set too low, system performance can be adversely affected because IRPCOUNTV cannot be used for nonpaged pool requests.

A physical memory penalty of 1 percent results for any unused growth space (1 longword for every 3 unused intermediate request packets).

#### **JBOBLIM**

This parameter is no longer in use.

#### **JOBCTLD**

System managers do not usually alter JOBCTLD; this word of debug flags is used in rolling upgrades of OpenVMS. If bit 0 is set, the queue manager does not start. The default is 0.

This special parameter is used by HP and is subject to change. Do not change this parameter unless HP recommends that you do so.

#### **KSTACKPAGES**

(Alpha and Integrity servers) KSTACKPAGES controls the number of pages allocated for process kernel stacks.

#### **LAN\_FLAGS (D)**

(Alpha and Integrity servers) LAN\_FLAGS is a bit mask used to enable features in the local area networks port drivers and support code. The default value for LAN\_FLAGS is 0.

## System Parameters

### D.2 Parameter Descriptions

The bit definitions are as follows:

| Bit            | Description  |
|----------------|--|
| 0              | The default of zero indicates that ATM devices run in SONET mode. If set to 1, this bit indicates ATM devices run in SDH mode.   |
| 1              | If set, this bit enables a subset of the ATM trace and debug messages in the LAN port drivers and support code.  |
| 2              | If set, this bit enables all ATM trace and debug messages in the LAN port drivers and support code.  |
| 3 <sup>1</sup> | If set, this bit runs UNI 3.0 over all ATM adapters.   |
| 4 <sup>1</sup> | If set, this bit runs UNI 3.1 over all ATM adapters.   |
| 5              | If set, disables auto-negotiation over all Gigabit Ethernet Adapters.  |
| 6              | If set, enables the use of jumbo frames over all Gigabit Ethernet Adapters.  |
| 7              | Reserved.  |
| 8              | If set, disables the use of flow control over all LAN adapters that support flow control.  |
| 9              | Reserved.  |
| 10             | Reserved.  |
| 11             | If set, disables the logging of error log entries by LAN drivers.  |
| 12             | If set, enables a fast timeout on transmit requests, usually between 1 and 1.2 seconds instead of 3 to 4 seconds, for most LAN drivers.  |
| 13             | If set, transmits that are given to the LAN device and never completed by the device (transmit timeout condition) are completed with error status (SS\$_ABORT) rather than success status (SS\$_NORMAL). |

<sup>1</sup>Auto-sensing of the ATM UNI version is enabled if both bit 3 and bit 4 are off (0).

#### LCKMGR\_CPUID (D)

(Alpha and Integrity servers) LCKMGR\_CPUID controls the CPU that the Dedicated CPU Lock Manager runs on. This is the CPU that the LCKMGR\_SERVER process utilizes if you turn this feature on with the LCKMGR\_MODE system parameter.

If the specified CPU ID is either the primary CPU or a nonexistent CPU, the LCKMGR\_SERVER process utilizes the lowest nonprimary CPU. For more information, see the LCKMGR\_MODE system parameter.

#### LCKMGR\_MODE (D)

(Alpha and Integrity servers) The LCKMGR\_MODE parameter controls use of the Dedicated CPU Lock Manager. Setting LCKMGR\_MODE to a number greater than zero (0) indicates the number of CPUs that must be active before the Dedicated CPU Lock Manager is turned on.

The Dedicated CPU Lock Manager performs all locking operations on a single dedicated CPU. This can improve system performance on large SMP systems with high MP\_Synch associated with the lock manager.

If the number of active CPUs is greater than or equal to LCKMGR\_MODE, a LCKMGR\_SERVER process is created to service locking operations. This process runs at a real-time priority of 63 and is always current.

## System Parameters

### D.2 Parameter Descriptions

In addition, if the number of active CPUs should ever be reduced below the required threshold by either a STOP/CPU command or by a CPU reassignment in a Galaxy configuration, the Dedicated CPU Lock Manager automatically turns off within one second, and the LCKMGR\_SERVER is placed in a hibernate state. If the number of active CPUs is increased, the LCKMGR\_SERVER resumes servicing locking operations.

Specify one of the following:

- Zero (0) indicates that the Dedicated CPU Lock Manager is off (the default).
- A number greater than zero (0) indicates the number of CPUs that must be active before the Dedicated CPU Lock Manager will turn on.

When the Dedicated CPU Lock Manager is turned on, fast path devices are not assigned to the CPU used by the Dedicated CPU Lock Manager.

When the Dedicated CPU Lock Manager is turned on, fast path devices are not assigned to the CPU used by the Dedicated CPU Lock Manager.

For more information about use of the Dedicated CPU Lock Manager, see the *OpenVMS Performance Management* manual.

#### **LGI\_BRK\_DISUSER (D)**

LGI\_BRK\_DISUSER turns on the DISUSER flag in the UAF record when an attempted break-in is detected, thus permanently locking out that account. The parameter is off (0) by default. You should set the parameter (1) only under extreme security watch conditions, because it results in severely restricted user service.

#### **LGI\_BRK\_LIM (D)**

LGI\_BRK\_LIM specifies the number of failures that can occur at login time before the system takes action against a possible break-in. The count of failures applies independently to login attempts by each user name, terminal, and node. Whenever login attempts from any of these sources reach the break-in limit specified by LGI\_BRK\_LIM, the system assumes it is under attack and initiates evasive action as specified by the LGI\_HID\_TIM parameter.

The minimum value is 1. The default value is usually adequate.

#### **LGI\_BRK\_TERM (D)**

LGI\_BRK\_TERM causes the terminal name to be part of the association string for the terminal mode of break-in detection. When LGI\_BRK\_TERM is set to off (0), the processing considers the local or remote source of the attempt, allowing break-in detection to correlate failed access attempts across multiple terminal devices. When set to on (1), LGI\_BRK\_TERM assumes that only local hard-wired or dedicated terminals are in use and causes breakin detection processing to include the specific local terminal name when examining and correlating break-in attempts.

Ordinarily, LGI\_BRK\_TERM should be set to off (0) when physical terminal names are created dynamically, such as when network protocols like LAT and Telnet are in use.

#### **LGI\_BRK\_TMO (D)**

LGI\_BRK\_TMO specifies the length of the failure monitoring period. This time increment is added to the suspect's expiration time each time a login failure occurs. Once the expiration period passes, prior failures are discarded, and the suspect is given a clean slate.

## System Parameters

### D.2 Parameter Descriptions

#### **LGI\_CALLOUTS (D)**

LGI\_CALLOUTS specifies the number of installation security policy callout modules to be invoked at each login. LGI\_CALLOUTS must be set to 0 unless callout modules are present.

#### **LGI\_HID\_TIM (D)**

LGI\_HID\_TIM specifies the number of seconds that evasive action persists following the detection of a possible break-in attempt. The system refuses to allow any logins during this period, even if a valid user name and password are specified.

#### **LGI\_PWD\_TMO (D)**

LGI\_PWD\_TMO specifies, in seconds, the period of time a user has to enter the correct system password (if used). LGI\_PWD\_TMO also establishes the timeout period for users to enter their personal account passwords at login time. Also, when using the SET PASSWORD command, LGI\_PWD\_TMO specifies the period of time the system waits for a user to type in a new password, an old password, and the password verification.

#### **LGI\_RETRY\_LIM (D)**

LGI\_RETRY\_LIM specifies the number of retry attempts allowed users attempting to log in. If this parameter is greater than 0, and a legitimate user fails to log in correctly because of typing errors, the user does not automatically lose the carrier. Instead (provided that LGI\_RETRY\_TMO has not elapsed), by pressing the Return key, the user is prompted to enter the user name and password again. Once the specified number of attempts has been made without success, the user loses the carrier. As long as neither LGI\_BRK\_LIM nor LGI\_BRK\_TMO has elapsed, the user can dial in again and reattempt login.

#### **LGI\_RETRY\_TMO (D)**

LGI\_RETRY\_TMO specifies the number of seconds allowed between login retry attempts after each login failure. (Users can initiate login retries by pressing the Return key.) This parameter is intended to be used with the LGI\_RETRY\_LIM parameter; it allows dialup users a reasonable amount of time and number of opportunities to attempt logins before they lose the carrier.

#### **LNMPHASHTBL (A on VAX,G)**

LNMPHASHTBL sets the size of the process logical name hash table. Logical names are hashed using a function of the name length and contents. The LNMPHASHTBL parameter determines the number of entries for process-private logical names. The recommended setting is the average number of process-private logical names. Note that the hashed values are rounded up to the nearest power of 2.

#### **LNMSHASHTBL (A,F,G)**

LNMSHASHTBL sets the size of the system logical name hash table. Logical names are hashed using a function of the name length and contents. The LNMSHASHTBL parameter determines the number of entries for shareable logical names. These names include all names from the system, group, and job logical name tables. The recommended setting allows one to four logical names per hash table entry. The default setting is usually adequate, unless your installation has a large number of groups, or many jobs are active simultaneously. In that case, an increase in the value of the next higher power of 2 might improve logical name translation performance. Note that the hashed values are rounded up to the nearest power of 2.

## System Parameters

### D.2 Parameter Descriptions

#### LOAD\_PWD\_POLICY

LOAD\_PWD\_POLICY controls whether the SET PASSWORD command attempts to use site-specific password policy routines, which are contained in the shareable image SYS\$LIBRARY:VMS\$PASSWORD\_POLICY.EXE. The default is 0, which indicates not to use policy routines.

#### LOAD\_SYS\_IMAGES (A on Alpha and Integrity servers)

This special parameter is used by HP and is subject to change. Do not change this parameter unless HP recommends that you do so.

LOAD\_SYS\_IMAGES controls the loading of system images described in the system image data file, VMS\$SYSTEM\_IMAGES. This parameter is a bit mask.

On Alpha and Integrity servers, the following bits are defined:

| Bit                        | Description  |
|----------------------------|--|
| 0 (SGN\$V_LOAD_SYS_IMAGES) | Enables loading alternate execlets specified in VMS\$SYSTEM_IMAGES.DATA.         |
| 1 (SGN\$V_EXEC_SLICING)    | Enables executive slicing.   |
| 2 (SGN\$V_RELEASE_PFNS)    | Enables releasing unused portions of the Alpha and Integrity servers huge pages. |

These bits are on by default. Using conversational bootstrap exec slicing can be disabled.

#### LOCKDIRWT (A)

LOCKDIRWT determines the portion of lock manager directory that this system handles. The default value is usually adequate.

#### LOCKIDTBL (A,F,M)

LOCKIDTBL sets the initial number of entries in the system Lock ID table and defines the amount by which the Lock ID table is extended whenever the system runs out of locks. One entry must exist for each lock in the system; each entry requires 4 bytes.

For simple timesharing systems, the default value is adequate. If your application uses many locks, as in the case of heavy RMS file sharing or a database management application, you should increase this parameter. When you change the value of LOCKIDTBL, examine the value of RESHASHTBL and change it if necessary.

The OpenVMS Lock Management facility is described in the *HP OpenVMS Programming Concepts Manual*. You can monitor locks with the MONITOR LOCK command of the Monitor utility.

#### LOCKIDTBL\_MAX

LOCKIDTBL\_MAX is obsolete beginning with OpenVMS Version 7.1.

#### LOCKRETRY

LOCKRETRY establishes the number of attempts made to lock a multiprocessor data structure.

This special parameter is used by HP and is subject to change. Do not change this parameter unless HP recommends that you do so.

## System Parameters

### D.2 Parameter Descriptions

#### LOCKRMWT (D)

---

##### Note

---

On OpenVMS Version 8.3 systems, LOCKRMWT does not control lock remastering. See LOCKDIRWT.

---

LOCKRMWT can have a value from zero to 10. The default is 5. Remaster decisions are based on the difference in lock remaster weights between the master and a remote node. When weights are equal, the remote node needs about 13% more activity before the tree is remastered. If a remote node has a higher lock remaster weight, the amount of activity is less. If the remote node has a lower lock remaster weight, the additional activity required to move the tree is much greater.

Lock remaster weights of zero and 10 have additional meanings. A value of zero indicates that a node does not want to master trees and always remasters to an interested node with a higher LOCKRMWT. Lock trees on an interested node with a LOCKRMWT lower than 10 are remastered to the node with a weight of 10 for LOCKRMWT.

#### LONGWAIT (A on Alpha and Integrity servers, D,G,M)

LONGWAIT defines how much real time (in seconds) must elapse before the swapper considers a process to be temporarily idle. This parameter is applied to local event flag (LEF) and hibernate (HIB) waits to detect such conditions as an inactive terminal or ACP.

#### MAXBOBMEM (D)

(Alpha and Integrity servers) MAXBOBMEM defines the maximum amount of physical memory, measured in pagelets, that can be associated with a single buffer object created by a process in user mode. The default value of 0 means there is no system-imposed limit on the size of a buffer object.

Other MAXBOB\* parameters are obsolete beginning with OpenVMS Version 7.3.

#### MAXBUF (D)

MAXBUF sets the maximum allowable size for any single buffered I/O packet. Buffered I/O packets are allocated from the permanently resident nonpaged dynamic pool. The terminal, mailbox, and printer device drivers are examples of device drivers that perform buffered I/O.

The number of bytes specified in the I/O request plus the size of a driver-dependent and function-dependent header area determine the required buffered I/O packet size. The size of the header area is a minimum of 16 bytes; there is no absolute upper limit. However, this header area is usually a few hundred bytes in size.

The default value on Alpha and Integrity servers continues to be 8192.

The maximum value of MAXBUF is 64000 bytes.

#### MAXCLASSPRI (D)

If class scheduling is enabled, MAXCLASSPRI sets the maximum range in the priority range of class-scheduled processes.



## System Parameters

### D.2 Parameter Descriptions

This special parameter is used by HP and is subject to change. Do not change this parameter unless HP recommends that you do so.

#### **MAXPROCESSCNT (A,F,G,M)**

MAXPROCESSCNT sets the number of process entry slots allocated at bootstrap time. One slot is required for each concurrent process on the system. Each slot requires 6 bytes of permanently resident memory.

The default value is normally configured to allow you to create the desired number of processes. If the following message appears, you need to increase the value of MAXPROCESSCNT:

```
%SYSTEM-F-NOSLOT, No PCB to create process
```

On Alpha and Integrity servers beginning with Version 8.1, the default value is 32,767.

#### **MAXQUEPRI (D)**

MAXQUEPRI determines the highest scheduling priority that can be assigned to jobs entered in batch and output (printer, server, and terminal) queues without the submitter process having OPER or ALTPRI privilege. The value of this parameter can range from 0 to 255; the default is 100. The value of MAXQUEPRI should be greater than or equal to DEFQUEPRI.

---

#### **Note**

---

MAXQUEPRI refers to relative queue scheduling priority, not to the execution priority of the job.

---

#### **MAXSYSGROUP (D)**

MAXSYSGROUP sets the highest value that a group number can have and still be classified as a system UIC group number. Note that the specification is not in octal unless preceded by the %O radix indicator. This parameter is normally left at 8 (10 octal).

#### **MC\_SERVICES\_P0 (D)**

(Alpha only) MC\_SERVICES\_P0 controls whether other MEMORY CHANNEL nodes in the cluster continue to run if this node bugchecks or shuts down.

A value of 1 causes other nodes in the MEMORY CHANNEL cluster to crash with bugcheck code MC\_FORCED\_CRASH if this node bugchecks or shuts down.

The default value is 0. A setting of 1 is intended only for debugging purposes; the parameter should otherwise be left at its default value.

#### **MC\_SERVICES\_P1 (D)**

(Alpha only) This special parameter is reserved for HP use. Its value must be the same on all nodes connected by MEMORY CHANNEL.

#### **MC\_SERVICES\_P2**

(Alpha only) MC\_SERVICES\_P2 specifies whether to load the PMDRIVER (PMA0) MEMORY CHANNEL cluster port driver.

PMDRIVER is a driver that serves as the MEMORY CHANNEL cluster port driver. It works together with MCDRIVER (the MEMORY CHANNEL device driver and driver interface) to provide MEMORY CHANNEL clustering. If

## System Parameters

### D.2 Parameter Descriptions

PMDRIVER is not loaded, cluster connections are not made over the MEMORY CHANNEL interconnect.

The default value is 1, which causes PMDRIVER to be loaded when you boot the system. When you run CLUSTER\_CONFIG.COM and select the MEMORY CHANNEL option, PMDRIVER is loaded automatically when you reboot the system.

HP recommends that this value not be changed. This parameter value must be the same on all nodes connected by MEMORY CHANNEL.

#### **MC\_SERVICES\_P3 (D)**

(Alpha only) MC\_SERVICES\_P3 specifies the maximum number of tags supported. The maximum value is 2048, and the minimum value is 100.

The default value is 800. HP recommends that this value not be changed. This parameter value must be the same on all nodes connected by MEMORY CHANNEL.

#### **MC\_SERVICES\_P4**

(Alpha only) MC\_SERVICES\_P4 specifies the maximum number of regions supported. The maximum value is 4096, and the minimum value is 100.

The default value is 200. HP recommends that this value not be changed. This parameter value must be the same on all nodes connected by MEMORY CHANNEL.

#### **MC\_SERVICES\_P5 (D)**

(Alpha only) MC\_SERVICES\_P5 is reserved for HP use only and must remain at the default value of 8000000. This value must be the same on all nodes connected by MEMORY CHANNEL.

#### **MC\_SERVICES\_P6**

(Alpha only) MC\_SERVICES\_P6 specifies MEMORY CHANNEL message size, the body of an entry in a free queue, or a work queue. The maximum value is 65536, and the minimum value is 544.

The default value is 992. This value is suitable in all cases except for systems with highly constrained memory. For such systems, you can reduce the memory consumptions of MEMORY CHANNEL by slightly reducing the default value of 992. The value of MC\_SERVICES\_P6 must always be equal to or greater than the result of the following calculations:

1. Select the larger of SCS\_MAXMSG and SCS\_MAXDG.
2. Round that value up to the next quadword.

The value of MC\_SERVICES\_P6 must be the same on all nodes connected by MEMORY CHANNEL.

#### **MC\_SERVICES\_P7 (D)**

(Alpha only) MC\_SERVICES\_P7 specifies whether to suppress or display messages about MEMORY CHANNEL activities on this node. This parameter can be set to a value of 0, 1, or 2:

- A value of 0 indicates nonverbose mode: no informational messages appear on the console or in the error log.
- A value of 1 indicates verbose mode: informational messages from both MCDRIVER and PMDRIVER appear on the console and in the error log.



## System Parameters

### D.2 Parameter Descriptions

- A value of 2 provides the same output as a value of 1, with the addition of PMDRIVER stalling and recovery messages.

The default value is 0. HP recommends that this value not be changed except while debugging MEMORY CHANNEL problems or adjusting the MC\_SERVICES\_P9 parameter.

#### **MC\_SERVICES\_P8**

(Alpha only) MC\_SERVICES\_P8 is reserved for HP use only and must remain at the default value of 0. The value must be the same on all nodes connected by MEMORY CHANNEL.

#### **MC\_SERVICES\_P9**

(Alpha only) MC\_SERVICES\_P9 specifies the number of initial entries in a single channel's free queue. The maximum value is 2048, and the minimum value is 10.

Note that MC\_SERVICES\_P9 is not a dynamic parameter; you must reboot the system after each change for that change to take effect.

The default value is 150. HP recommends that this value not be changed.

The value of MC\_SERVICES\_P9 must be the same on all nodes connected by MEMORY CHANNEL.

#### **MINCLASSPRI (D)**

If class scheduling is enabled, MINCLASSPRI sets the minimum range in the priority range of class-scheduled processes.

This special parameter is used by HP and is subject to change. Do not change this parameter unless HP recommends that you do so.

#### **MINWSCNT (A)**

The value specified by MINWSCNT is added to the size of the process header to establish the minimum working set size.

On Alpha and Integrity servers, MINWSCNT sets the minimum number of pages required for the execution of a process. The default value is 20; the minimum value is 10.

#### **MMG\_CTLFLAGS (A,D)**

MMG\_CTLFLAGS is a bitmask used to enable or disable memory management-related activities.

The first two bits, 0 and 1, control the proactive memory reclamation mechanisms. Bit 2 controls deferred memory testing.

The following bit mask values are defined:

| Bit | Description  |
|-----|--|
| 0   | If this bit is set, reclamation is enabled by trimming from periodically executing, but otherwise idle, processes. This occurs when the size of the free list plus the modified list drops below two times the value of FREEGOAL. This function is disabled if the bit is clear. |
| 1   | If this bit is set, reclamation is enabled by outswapping processes that have been idle for longer than LONGWAIT seconds. This occurs when the size of the free list drops below FREEGOAL. This function is disabled if the bit is clear.  |

## System Parameters

### D.2 Parameter Descriptions

| Bit | Description  |
|-----|--|
| 2   | Controls deferred memory testing (only on AlphaServer 4100 systems). You can use this bit to speed up elapsed bootstrap time by controlling when memory is tested: <ul style="list-style-type: none"><li>• If the bit is clear (the default), OpenVMS tests memory as a background activity, which might or might not complete before the end of the bootstrap process.</li><li>• If the bit is set, all memory is tested in the bootstrap process by the end of the EXEC_INIT phase (that is, before IPL is lowered from 31).</li></ul> |
| 3   | Reserved to OpenVMS use; must be zero.   |
| 4   | If this bit is clear (the default), all page sizes supported by hardware can be used to map resident memory sections on Integrity servers. If this bit is set, page sizes on Integrity servers are limited to the maximum GH factor available on Alpha systems (512 * <system page size>).   |
| 5-7 | Reserved for future use.   |

#### **MOUNTMSG (D)**

MOUNTMSG controls whether or not the messages that log volume mounts appear on the operator's terminal and in the operator's log. The default value of 0 disables reporting of these messages. This parameter does not control the messages generated by mount assistance requests.

#### **MPDEV\_AFB\_INTVL**

(Alpha and Integrity servers) MPDEV\_AFB\_INTVL specifies the automatic failback interval in seconds. The automatic failback interval is the minimum number of seconds that must elapse before the system attempts another failback from an MSCP path to a direct path on the same device.

MPDEV\_POLLER must be set to ON to enable automatic failback. You can disable automatic failback without disabling the poller by setting MPDEV\_AFB\_INTVL to 0. The default is 300 seconds.

#### **MPDEV\_D\***

(Alpha and Integrity servers) MPDEV\_D1 through MPDEV\_D4 are reserved for use by the operating system.

#### **MPDEV\_ENABLE**

(Alpha and Integrity servers) MPDEV\_ENABLE enables the formation of multipath sets when set to ON (1). If MPDEV\_ENABLE is set to OFF (0), the formation of additional multipath sets and the addition of new paths to existing multipath sets are disabled. However, existing multipath sets remain in effect. The default is ON.

MPDEV\_REMOTE and MPDEV\_AFB\_INTVL have no effect when MPDEV\_ENABLE is set to OFF.

#### **MPDEV\_LCRETRIES**

(Alpha and Integrity servers) MPDEV\_LCRETRIES controls the number of times the system retries the direct paths to the controller that the logical unit is online to, before moving on to direct paths to the other controller, or to an MSCP served path to the device. The valid range for retries is 1 through 256. The default is 1.

#### **MPDEV\_POLLER**

(Alpha and Integrity servers) MPDEV\_POLLER enables polling of the paths to multipath set members when set to ON (1). Polling allows early detection of errors on inactive paths. If a path becomes unavailable or returns to service, the system manager is notified with an OPCOM message. When set to OFF (0), multipath polling is disabled. The default is ON. Note that this parameter must be set to ON to use the automatic failback feature.

#### **MPDEV\_REMOTE**

(Alpha and Integrity servers) MPDEV\_REMOTE enables MSCP served paths to become members of a multipath set when set to ON (1). When set to OFF (0), only local paths to a SCSI or Fibre Channel device is used in the formation of additional multipath sets. However, setting this parameter to OFF does not have any effect on existing multipath sets that have remote paths.

To use multipath failover to a served path, MPDEV\_REMOTE must be enabled on all systems that have direct access to shared SCSI/Fibre Channel devices. The first release to provide this feature is OpenVMS Alpha Version 7.3-1. Therefore, all nodes on which MPDEV\_REMOTE is enabled must be running OpenVMS Alpha Version 7.3-1 (or later).

If MPDEV\_ENABLE is set to OFF (0), the setting of MPDEV\_REMOTE has no effect because the addition of all new paths to multipath sets is disabled. The default is ON.

#### **MPW\_HILIMIT (A,G)**

MPW\_HILIMIT sets an upper limit for the modified-page list. When the list accumulates the number of pages specified by this limit, writing of the list begins. The pages that are written are then transferred to the free-page list.

If MPW\_HILIMIT is too low, excessive page faulting can occur from the page file. If it is too high, too many physical pages can be consumed by the modified-page list.

If you increase MPW\_HILIMIT, you might also need to increase MPW\_WAITLIMIT. Note that if MPW\_WAITLIMIT is less than MPW\_HILIMIT, a system deadlock occurs. The values for the two parameters are usually equal.

#### **MPW\_IOLIMIT (A on Alpha and Integrity servers)**

MPW\_IOLIMIT specifies the number of outstanding I/Os to the modified-page writer.

#### **MPW\_LOLIMIT (A,G)**

MPW\_LOLIMIT sets a lower limit for the modified-page list. When writing of the list causes the number of pages on the list to drop to or below this limit, writing stops.

MPW\_LOLIMIT ensures that a certain number of pages are available on the modified-page list for page faults. If the number is too small, the caching effectiveness of the modified-page list is reduced. If it is too high, less memory is available for processes, so that swap (and page) may increase.

#### **MPW\_LOWAITLIMIT (A,D)**

MPW\_LOWAITLIMIT specifies the threshold at which processes in the miscellaneous wait state MPWBUSY are allowed to resume.

MPW\_LOWAITLIMIT increases system performance for fast processors with large memories by reducing the amount of time processes spend in the MPWBUSY wait state.

## System Parameters

### D.2 Parameter Descriptions

#### **MPW\_PRIO**

MPW\_PRIO sets the priority of I/O transfers initiated by the modified page writer. The maximum value is 31, the minimum is 0, and the default is 4.

This special parameter is used by HP and is subject to change. Do not change this parameter unless HP recommends that you do so.

#### **MPW\_THRESH (A on Alpha and Integrity servers,D)**

MPW\_THRESH sets a lower bound of pages that must exist on the modified-page list before the swapper writes this list to acquire free pages. If this requirement is met, the swapper tries to write the modified-page list rather than taking pages away from or swapping out a process.

#### **MPW\_WAITLIMIT (A,D)**

MPW\_WAITLIMIT sets the number of pages on the modified-page list that causes a process to wait until the next time the modified-page writer writes the modified list. This parameter limits the rate at which any single process can produce modified pages. If this value is less than MPW\_HILIMIT, a system deadlock occurs. The value for this parameter is normally equal to MPW\_HILIMIT.

#### **MPW\_WRTCLUSTER (A,G)**

MPW\_WRTCLUSTER sets the number of pages to be written during one I/O operation from the modified-page list to the page file or a section file. The actual size of the cluster may be limited by the number of pages available for the I/O operation. This parameter can range in value from 16 to 120, in multiples of 8. Each page in the cluster requires 6 bytes of permanently resident memory.

If MPW\_WRTCLUSTER is too small, it takes many I/O operations to empty the modified-page list. If MPW\_WRTCLUSTER is too large for the speed of the disk that holds the page file, other I/O operations are held up for the modified-page list write.

On Alpha and Integrity servers, the MPW\_WRTCLUSTER default value is 64 8192-byte pages; its maximum value is 512 8192-byte pages; and its minimum value is 16 8192-byte pages.

#### **MSCP\_BUFFER (A,F)**

This buffer area is the space used by the server to transfer data between client systems and local disks.

On Alpha and Integrity servers, MSCP\_BUFFER specifies the number of pagelets to be allocated to the MSCP server's local buffer area.

#### **MSCP\_CMD\_TMO (D)**

MSCP\_CMD\_TMO is the time in seconds that the OpenVMS MSCP server uses to detect MSCP command timeouts. The MSCP Server must complete the command within a built-in time of approximately 40 seconds plus the value of the MSCP\_CMD\_TMO parameter.

The MSCP\_CMD\_TMO default value of 0 is normally adequate. A value of 0 provides the same behavior as in previous releases of OpenVMS (which did not have an MSCP\_CMD\_TMO system parameter). A nonzero setting increases the amount of time before an MSCP command times out.

If command timeout errors are being logged on client nodes, setting the parameter to a nonzero value on OpenVMS servers reduces the number of errors logged. Increasing the value of this parameter reduces the numb client MSCP command timeouts and increases the time it takes to detect faulty devices.

## System Parameters

### D.2 Parameter Descriptions

If you need to decrease the number of command timeout errors, HP recommends that you set an initial value of 60. If timeout errors continue to be logged, you can increase this value in increments of 20 seconds.

#### **MSCP\_CREDITS**

MSCP\_CREDITS specifies the number of outstanding I/O requests that can be active from one client system.

The default value is currently 32. Unless a system has very constrained memory available, HP recommends that these values not be increased.

#### **MSCP\_LOAD (A)**

MSCP\_LOAD controls the loading of the MSCP server during a system boot. Specify one of the following values:

| Value | Description  |
|-------|--|
| 0     | Do not load the MSCP server. This is the default value.                            |
| 1     | Load the MSCP server and serve disks as specified by the MSCP_SERVE_ALL parameter. |

#### **MSCP\_SERVE\_ALL**

MSCP\_SERVE\_ALL is a bit mask that controls disk serving in an OpenVMS Cluster. A disk is served regardless of its allocation class unless bit 3 has a value of 1.

Starting with OpenVMS Version 7.2, the serving types are implemented as a bit mask. To specify the type of serving your system will perform, locate the type you want in the following table and specify its value. For some systems, you may want to specify two serving types, such as serving the system disk and serving locally attached disks. To specify such a combination, add the values of each type, and specify the sum.

In a mixed-version cluster that includes any systems running OpenVMS Version 7.1-x or earlier, serving all available disks is restricted to serving all disks except those whose allocation class does not match the system's node allocation class (prior to Version 7.2). To specify this type of serving, use the value 9 (which sets bit 0 and bit 3).

The following table describes the serving type controlled by each bit and its decimal value:

| Bit and Value When Set | Description   |
|------------------------|---|
| Bit 0 (1)              | Serve all available disks (locally attached and those connected to HSx and DSSI controllers). Disks with allocation classes that differ from the system's allocation class (set by the ALLOCLASS parameter) are also served if bit 3 is not set.  |
| Bit 1 (2)              | Serve locally attached (non-HSx and DSSI) disks.  |
| Bit 2 (4)              | Serve the system disk. This is the default setting. This setting is important when other nodes in the cluster rely on this system being able to serve its system disk. This setting prevents obscure contention problems that can occur when a system attempts to complete I/O to a remote system disk whose system has failed. |

## System Parameters

### D.2 Parameter Descriptions

| Bit and Value When Set | Description   |
|------------------------|---|
| Bit 3 (8)              | <p>Restrict the serving specified by bit 0. All disks except those with allocation classes that differ from the system's allocation class (set by the ALLOCLASS parameter) are served.</p> <p>This is pre-Version 7.2 behavior. If your cluster includes systems running OpenVMS 7.1-x or earlier, and you want to serve all available disks, you must specify 9, the result of setting this bit and bit 0.</p> |

Although the serving types are now implemented as a bit mask, the values of 0, 1, and 2, specified by bit 0 and bit 1, retain their original meanings:

- 0 — Do not serve any disks (the default for earlier versions of OpenVMS).
- 1 — Serve all available disks.
- 2 — Serve only locally attached (non-HSx and non-DSSI) disks.

If the MSCP\_LOAD system parameter is 0, MSCP\_SERVE\_ALL is ignored.

#### MULTIPROCESSING

MULTIPROCESSING controls the loading of the system synchronization image.

Specify one of the following values:

| Value | Description   |
|-------|---|
| 0     | Load the uniprocessing synchronization image SYSTEM_SYNCHRONIZATION_UNI.EXE.  |
| 1     | If the CPU type is capable of SMP and two or more CPUs are present on the system, load the full-checking multiprocessing synchronization image SYSTEM_SYNCHRONIZATION.EXE. Otherwise, load the uniprocessing synchronization image SYSTEM_SYNCHRONIZATION_UNI.EXE.  |
| 2     | Always load the full-checking version SYSTEM_SYNCHRONIZATION.EXE, regardless of system configuration or CPU availability.   |
| 3     | <p>If the CPU type is capable of SMP and two or more CPUs are present on the system, load the optimized streamlined multiprocessing image:</p> <ul style="list-style-type: none"> <li>• On Alpha and Integrity servers, this image is SYSTEM_SYNCHRONIZATION_MIN.EXE.</li> </ul> <p>Otherwise, load the uniprocessing synchronization image SYSTEM_SYNCHRONIZATION_UNI.EXE. The default value is 3.</p> |
| 4     | Always load the streamlined multiprocessing image SYSTEM_SYNCHRONIZATION_MIN.EXE, regardless of system configuration or CPU availability.   |

Setting the SYSTEM\_CHECK parameter to 1 has the effect of setting MULTIPROCESSING to 2.

#### MULTITHREAD (D,A)

MULTITHREAD controls the availability of kernel threads functions. Specify one of the following values:



## System Parameters

### D.2 Parameter Descriptions

| Value                               | Description   |
|-------------------------------------|---|
| 0                                   | Both Thread Manager upcalls and the creation of multiple kernel threads are disabled.   |
| 1                                   | Thread Manager upcalls are enabled; the creation of multiple kernel threads is disabled.  |
| 2-256 (Alpha and Integrity servers) | Both Thread Manager upcalls and the creation of multiple kernel threads are enabled. The number specified represents the maximum number of kernel threads that can be created for a single process. |

The maximum value for MULTITHREAD is 256.

#### **MVSUPMSG\_INTVL (D)**

(Alpha and Integrity servers) The system suppresses mount verification start and end messages for fibre channel disk devices if mount verification completes on the first attempt and if mount verification does not occur too often. MVSUPMSG\_NUM and this parameter establish this limit.

The system issues a mount verification message after a sequence of MVSUPMSG\_NUM mount verifications have gone unannounced on a specific fibre channel disk device within a span of MVSUPMSG\_INTVL seconds.

If this parameter is zero, all mount verification messages are announced.

#### **MVSUPMSG\_NUM (D)**

(Alpha and Integrity servers) The system suppresses mount verification start and end messages for fibre channel disk devices if mount verification completes on the first attempt and if mount verification does not occur too often. MVSUPMSG\_INTVL and this parameter establish this limit.

The system issues a mount verification message after a sequence of MVSUPMSG\_NUM mount verifications have gone unannounced on a specific fibre channel disk device within a span of MVSUPMSG\_INTVL seconds.

If this parameter is zero, all mount verification messages are announced.

#### **MVTIMEOUT (A on Alpha and Integrity servers,D)**

MVTIMEOUT is the time in seconds that a mount verification attempt continues on a given disk volume. If the mount verification does not recover the volume within that time, the I/O operations outstanding to the volume terminate abnormally.

#### **NET\_CALLOUTS (D)**

NET\_CALLOUTS is normally set to 0. A value of 255 indicates that no attempt is to be made to assign a new proxy connection to an active server, but that a new process must be started to invoke the installation security policy callout modules in LOGINOUT.EXE. Values 1 through 254 are reserved for future use.

#### **NISCS\_CONV\_BOOT**

NISCS\_CONV\_BOOT controls whether a conversational boot is permitted during a remote system boot. The default value of 0 specifies that conversational boots are not permitted.

#### **NISCS\_LOAD\_PEA0**

NISCS\_LOAD\_PEA0 controls whether the NI-SCS port driver PEDRIVER is loaded during system boot. The default of 0 specifies that the PEDRIVER is not loaded.

## System Parameters

### D.2 Parameter Descriptions

#### **NISCS\_MAX\_PKTSZ (A on Alpha and Integrity servers)**

This parameter specifies an upper limit on the size, in bytes, of the user data area in the largest packet sent by NISCA on any local area network (LAN).

NISCS\_MAX\_PKTSZ allows the system manager to change the packet size used for cluster communications on network communication paths. PEDRIVER automatically allocates memory to support the largest packet size that is usable by any virtual circuit connected to the system up to the limit set by this parameter. On Alpha and Integrity servers, to optimize performance, the default value is the largest packet size currently supported by OpenVMS.

PEDRIVER uses NISCS\_MAX\_PKTSZ to compute the maximum amount of data to transmit in any LAN packet:

```
LAN packet size <= LAN header (padded Ethernet format)
                    + NISCS_MAX_PKTSZ
                    + NISCS_checksum (only if data checking
                                      is enabled)
                    + LAN CRC or FCS
```

The actual packet size automatically used by PEDRIVER might be smaller than the NISCS\_MAX\_PKTSZ limit for any of the following reasons:

- On a per-LAN path basis, if PEDriver determines that the LAN path between two nodes, including the local and remote LAN adapters and intervening LAN equipment, can only convey a lesser size.  
  
In other words, only nodes with large-packet LAN adapters connected end-to-end by large-packet LAN equipment can use large packets. Nodes connected to large-packet LANs but having an end-to-end path that involves an Ethernet segment restrict packet size to that of an Ethernet packet (1498 bytes).
- For performance reasons, PEDRIVER might further limit the upper bound on packet size so that the packets can be allocated from a lookaside list in the nonpaged pool.

The actual memory allocation includes the required data structure overhead used by PEDRIVER and the LAN drivers, in addition to the actual LAN packet size.

The following table shows the minimum NISCS\_MAX\_PKTSZ value required to use the maximum packet size supported by specified LAN types:

| Type of LAN      | Minimum Value for NISCS_MAX_PKTSZ                         |
|------------------|---|
| Ethernet         | 1498  |
| FDDI             | 4382 (before Version 7.3)<br>4396 (Version 7.3 and later) |
| Gigabit Ethernet | 8192  |
| ATM              | 7606  |

Note that the maximum packet size for some Gigabit Ethernet adapters is larger than the maximum value of NISCS\_MAX\_PKTSZ (8192 bytes). See the LAN\_FLAGS parameter for a description of how to enable jumbo frames on Gigabit Ethernet—that is, packet sizes larger than those noted for Ethernet.

#### **NISCS\_PORT\_SERV (A, D)**

NISCS\_PORT\_SERV provides flag bits for PEDRIVER port services:

- Setting bits 0 and 1 (hex bitmask value 3) enables data checking.



## System Parameters

### D.2 Parameter Descriptions

- Setting bit 2 (hex bitmask value 4) enables data compression on all virtual channels (VCs) to nodes that support compression.

The remaining bits are reserved for future use.

Starting with OpenVMS Version 7.3-1, you can use the SCACP command SET VC/CHECKSUMMING to specify data checking on the VCs to certain nodes. You can do this on a running system. (For more information, see the SCACP documentation in this manual.

Starting with OpenVMS Version 8.3, you can also use the SCACP command SET VC/COMPRESSION to specify data compression on the on the VCs to certain nodes. You can use SCACP to enable either data checking or data compression on a running system. (See the SCACP documentation in the the *HP OpenVMS System Management Utilities Reference Manual* for more information. Also starting with OpenVMS Version 8.3, the NISCS\_PORT\_SERV system parameter is dynamic, that is, changing the setting of this parameter no longer requires a reboot. Furthermore, this parameter applies to all virtual circuits between the node on which it is set and other nodes in the cluster.

#### **NOAUTOCONFIG (D)**

NOAUTOCONFIG controls whether all devices are automatically configured when the system boots. The default value of 0 sets the system to automatically configure all devices. Set NOAUTOCONFIG to 1 (no automatic configuration) *only* for debugging purposes.

This special parameter is used by HP and is subject to change. Do not change this parameter unless HP recommends that you do so.

#### **NOCLUSTER**

NOCLUSTER controls whether page read clustering is inhibited when the system boots. Set NOCLUSTER to 1 (inhibit page read clustering) *only* for debugging purposes.

This special parameter is used by HP and is subject to change. Do not change this parameter unless HP recommends that you do so.

#### **NOPGFLSWP**

If enabled, NOPGFLSWP disables swapping into page files.

This special parameter is used by HP and is subject to change. Do not change this parameter unless HP recommends that you do so.

#### **NPAGECALC**

NPAGECALC controls whether the system automatically calculates the initial size for nonpaged dynamic memory.

HP sets the default value of NPAGECALC to 1 only during the initial boot after an installation or upgrade. When the value of NPAGECALC is 1, the system calculates an initial value for the NPAGEVIR and NPAGEDYN system parameters. This calculated value is based on the amount of physical memory in the system.

NPAGECALC's calculations do not reduce the values of NPAGEVIR and NPAGEDYN from the values you see or set at the SYSBOOT prompt. However, NPAGECALC's calculation might increase these values.

AUTOGEN sets NPAGECALC to 0. NPAGECALC should always remain 0 after AUTOGEN has determined more refined values for the NPAGEDYN and NPAGEVIR system parameters.

## System Parameters

### D.2 Parameter Descriptions

#### NPAGEDYN (A,F,G,M)

NPAGEDYN sets the size of the nonpaged dynamic pool in bytes. This figure is rounded down to an integral number of pages. NPAGEDYN establishes the initial setting of the nonpaged pool size, but the pool size can be increased dynamically.

To set a value for this parameter, use AUTOGEN initially, and then monitor the amount of space actually used with the DCL command SHOW MEMORY/POOL/FULL.

For the benefit of OpenVMS VAX systems with limited physical memory, AUTOGEN logs a warning message in its report if NPAGEDYN exceeds 10 percent of physical memory or if NPAGEVIR exceeds 33 percent of physical memory.

AUTOGEN also limits its own calculated value for NPAGEDYN to 20 percent of physical memory and limits NPAGEVIR to 50 percent of physical memory. These calculated values are adequate for most workstations and systems with 16 or fewer megabytes of physical memory. If your system requires a larger value, you can override the AUTOGEN calculated values by setting higher values in MODPARAMS.DAT.

#### NPAGERAD (G)

(Alpha and Integrity servers) NPAGERAD specifies the total number of bytes of nonpaged pool that will be allocated for Resource Affinity Domains (RADs) other than the base RAD. For platforms that have no RADs, NPAGERAD is ignored. Notice that NPAGEDYN specifies the total amount of nonpaged pool for all RADs.

Also notice that the OpenVMS system might round the specified values higher to an even number of pages for each RAD, which prevents the base RAD from having too little nonpaged pool. For example, if the hardware is an AlphaServer GS160 with 4 RADs:

```
NPAGEDYN = 6291456 bytes
NPAGERAD = 2097152 bytes
```

In this case, the OpenVMS system allocates a total of approximately 6,291,456 bytes of nonpaged pool. Of this amount, the system divides 2,097,152 bytes among the RADs that are not the base RAD. The system then assigns the remaining 4,194,304 bytes to the base RAD.

---

#### Note

---

The system actually rounds up to an even number of pages on each RAD. In addition, the base RAD is never assigned a value less than the smaller of the value of NPAGEDYN and 4 megabytes.

---

On AlphaServer GS series processors on OpenVMS systems prior to Version 7.3-1, system managers frequently saw pool expansion that increasing NPAGEDYN did not reduce. This problem was caused by leaving NPAGERAD at its default value of 0.

Starting with OpenVMS Version 7.3-1, when NPAGERAD is 0 (the default), the system calculates a value to use for NPAGERAD with the following formula:

$$\text{NPAGEDYN} * \left( 1 - \frac{\text{Base RAD memory}}{\text{Total memory}} \right)$$

## System Parameters

### D.2 Parameter Descriptions

This calculation gives more pool to the non-base RADs than before and, therefore, reduces the expansion of non-base RADs.

#### **NPAGEVIR (A, G)**

NPAGEVIR defines the maximum size to which NPAGEDYN can be increased. If this value is too small, the system can hang. If NPAGEVIR is too large, the result is a penalty of 4 bytes per extra page on VAX and 8 bytes per extra page on Alpha and Integrity servers.

For the benefit of OpenVMS VAX systems with limited physical memory, AUTOGEN logs a warning message in its report if NPAGEDYN exceeds 10 percent of physical memory or if NPAGEVIR exceeds 33 percent of physical memory.

AUTOGEN also limits its own calculated value for NPAGEDYN to 20 percent of physical memory, and limits NPAGEVIR to 50 percent of physical memory. These calculated values are adequate for most workstations and systems with 16 or fewer megabytes of physical memory. If your system requires a larger value, you can override the AUTOGEN calculated values by setting higher values in MODPARAMS.DAT.

#### **NPAG\_AGGRESSIVE (D)**

Beginning with OpenVMS Version 8.2, the default values of NPAG\_AGGRESSIVE and NPAG\_GENTLE are 100. A value of 100 turns off both gentle and aggressive reclamation of nonpaged pool lookaside lists. In many cases, when pool reclamation moves small packets from the lookaside lists back to the variable list, the result is fragmentation of the variable list. This fragmentation appears as many small packets at the front of the variable list and a few large packets at the end of the list.

When an allocation occurs for a packet that is larger than any of the lookaside lists, the system must find a large enough packet on the variable list. When heavily fragmented, the entire variable list often must be searched to find a large enough packet. Because the variable list is kept in address order, when a large packet is deallocated, the entire list must be searched again to deallocate the packet.

Under these conditions, system performance can be severely degraded. For this reason, HP recommends that you turn off pool reclamation but keep both NPAG\_AGGRESSIVE and NPAG\_GENTLE system parameters set to 100.

#### **NPAG\_BAP\_MAX**

(Alpha and Integrity servers) NPAG\_BAP\_MAX is the size in bytes of the bus addressable pool (BAP) that the system creates under normal circumstances.

See also NPAG\_BAP\_MIN.

#### **NPAG\_BAP\_MAX\_PA**

(Alpha and Integrity servers) NPAG\_BAP\_MAX\_PA is the highest physical address in megabytes that is allowed in bus addressable pool (BAP).

#### **NPAG\_BAP\_MIN**

(Alpha and Integrity servers) NPAG\_BAP\_MIN is the size in bytes of the bus addressable pool (BAP) that the system creates when memory resources are unusually constrained.

## System Parameters

### D.2 Parameter Descriptions

#### **NPAG\_BAP\_MIN\_PA**

(Alpha and Integrity servers) NPAG\_BAP\_MIN\_PA specifies the lowest physical address in megabytes that is allowed in bus addressable pool (BAP).

#### **NPAG\_GENTLE (D)**

Beginning with Version 8.2, the default values of NPAG\_AGGRESSIVE and NPAG\_GENTLE are 100. A value of 100 turns off both gentle and aggressive reclamation of nonpaged pool lookaside lists. In many cases, when pool reclamation moves small packets from the lookaside lists back to the variable list, the result is fragmentation of the variable list. This fragmentation appears as many small packets at the front of the variable list and a few large packets at the end of the list.

When an allocation occurs for a packet that is larger than any of the lookaside lists, the system must find a large enough packet on the variable list. When heavily fragmented, the entire variable list often must be searched to find a large enough packet. Because the variable list is kept in address order, when a large packet is deallocated, the entire list must be searched again to deallocate the packet.

Under these conditions, system performance can be severely degraded. For this reason, HP recommends that you turn off pool reclamation but keep both NPAG\_AGGRESSIVE and NPAG\_GENTLE system parameters set to 100.

#### **NPAG\_INTERVAL (D)**

NPAG\_INTERVAL is the number of seconds between passes of nonpaged-pool gentle reclamation.

#### **NPAG\_RING\_SIZE**

NPAG\_RING\_SIZE represents the number of entries in the ring buffer.

#### **PAGED\_LAL\_SIZE (D,G,M)**

PAGED\_LAL\_SIZE sets the maximum size, in bytes, to use for the page dynamic pool lookaside lists. Use of these lookaside lists can reduce paged dynamic pool variable freelist fragmentation and improve paged pool allocation and deallocation performance.

By default, PAGED\_LAL\_SIZE is set to 0, which disables the use of the paged dynamic pool lookaside lists.

For environments experiencing paged pool variable freelist fragmentation a modest PAGED\_LAL\_SIZE, 512, has been adequate to improve paged pool performance and reduce fragmentation. If this parameter is made large and later decreased in size, some paged pool packets can be left unused until the parameter is made larger again, or the lookaside lists are reclaimed from due to a paged pool shortage. The paged dynamic pool lookaside lists will not occupy more than three-quarters of the available paged pool.

#### **PAGFILCNT (G)**

On Alpha and Integrity servers, beginning in OpenVMS Version 7.3, this parameter is obsolete.

#### **PAGTBLPFC**

PAGTBLPFC specifies (in pages) the maximum number of page tables to read to satisfy a fault for a nonresident page table.

This special parameter is used by HP and is subject to change. Do not change this parameter unless HP recommends that you do so.

## System Parameters

### D.2 Parameter Descriptions

#### **PAMAXPORT (D)**

PAMAXPORT specifies the maximum port number to be polled on each CI and DSSI. The CI and DSSI port drivers poll to discover newly initialized ports or the absence/failure of previously responding remote ports.

A system does not detect the existence of ports whose port numbers are higher than this parameter's value. Thus, set this parameter to a value that is equal to or greater than the highest port number being used on any CI or DSSI connected to the system.

You can decrease this parameter to reduce polling activity if the hardware configuration has fewer than 16 ports. For example, if the CI or DSSI with the largest configuration has a total of 5 ports assigned to port numbers 0 through 4, you could set PAMAXPORT to 4.

If CI or DSSI devices are not configured on your system, this parameter is ignored.

The default for this parameter is 15 (poll for all possible ports 0 through 15). HP recommends that you set this parameter to the same value on each cluster computer.

#### **PANOPOLL (D)**

Disables CI and DSSI polling for ports if set to 1. (The default is 0.) When PANOPOLL is set, a computer does not discover that another computer has shut down or powered down promptly and does not discover a new computer that has booted. This parameter is useful when you want to bring up a computer detached from the rest of the cluster for checkout purposes.

PANOPOLL is functionally equivalent to uncabling the system from the DSSI or star coupler. This parameter does not affect OpenVMS Cluster communications by LAN.

The default value of 0 is the normal setting and is required if you are booting from an HSC controller or if your system is joining an OpenVMS Cluster. This parameter is ignored if no CI or DSSI devices are configured on your system.

#### **PANUMPOLL (D)**

PANUMPOLL establishes the number of CI and DSSI ports to be polled each polling interval. The normal setting for PANUMPOLL is 16.

On systems with less powerful CPUs, the parameter may be useful in applications sensitive to the amount of contiguous time that the system spends at IPL 8. Reducing PANUMPOLL reduces the amount of time spent at IPL 8 during each polling interval, while increasing the number of polling intervals needed to discover new or failed ports.

If CI or DSSI devices are not configured on your system, this parameter is ignored.

#### **PAPOLLINTERVAL (D)**

Specifies, in seconds, the polling interval the CI port driver uses to poll for a newly booted computer, a broken port-to-port virtual circuit, or a failed remote computer.

This parameter trades polling overhead against quick response to virtual circuit failures. HP recommends that you use the default value for this parameter.

HP recommends that you set this parameter to the same value on each cluster computer.

## System Parameters

### D.2 Parameter Descriptions

#### **PAPOOLINTERVAL (D)**

Specifies, in seconds, the interval at which the port driver checks available nonpaged pool after a pool allocation failure.

This parameter trades faster response to pool allocation failures against increased polling overhead. HP recommends that you use the default value for this parameter.

If CI or DSSI devices are not configured on your system, this parameter is ignored.

#### **PASANITY (D)**

PASANITY controls whether the CI and DSSI port sanity timers are enabled to permit remote systems to detect a system that has been hung at IPL 8 or above for 100 seconds. It also controls whether virtual circuit checking gets enabled on the local system. The TIMVCFAIL parameter controls the time (1-99 seconds).

PASANITY is normally set to 1 and should be set to 0 only when you are debugging with XDELTA or planning to halt the CPU for periods of 100 seconds or more.

PASANITY is only semidynamic. A new value of PASANITY takes effect on the next CI or DSSI port reinitialization.

If CI or DSSI devices are not configured on your system, this parameter is ignored.

#### **PASTDGBUF (A)**

The number of datagram receive buffers to queue initially for the cluster port driver's configuration poller. The initial value is expanded during system operation, if needed.

Memory Channel devices ignore this parameter.

#### **PASTIMOUT (D)**

The basic interval at which the CI port driver wakes up to perform time-based bookkeeping operations. It is also the period after which a timeout is declared if no response to a start handshake datagram has been received.

If CI or DSSI devices are not configured on your system, this parameter is ignored.

The default value should always be adequate.

#### **PE\***

PE1, PE2, PE3, PE4, PE5, PE6 are reserved for HP use only. These parameters are for cluster algorithms and their usages can change from release to release. HP recommends using the default values for these special parameters.

#### **PFCDEFAULT (A,D)**

On Alpha and Integrity servers during execution of programs, PFCDEFAULT controls the number of image pagelets read from disk per I/O operation when a page fault occurs. The PFCDEFAULT maximum default value is 2032 512-byte pagelets (127 8192-byte Alpha and Integrity server pages).

The read I/O operations can take place from an image file or from the page file. The actual size of the cluster can be less than PFCDEFAULT, depending on the size of image sections and the pattern of page references.



## System Parameters

### D.2 Parameter Descriptions

The value should not be greater than one-fourth the default size of the average working set to prevent a single page fault from displacing a major portion of a working set. Too large a value for PFCDEFAULT can hurt system performance. PFCDEFAULT can be overridden on an image-by-image basis with the CLUSTER option of the OpenVMS linker.

#### **PFN\_COLOR\_COUNT**

(Alpha and Integrity servers) PFN\_COLOR\_COUNT specifies the number of buckets (colors) into which all members of the zeroed page list and all unencumbered members of the free page list are sorted. OpenVMS Alpha systems might derive a preferred page color from a request to map a given virtual page and attempt to map that virtual page to a PFN of matching “color.” This results in less variance in which cache blocks are used when accessing that page. This might or might not improve performance, depending on the application.

This special parameter is used by HP and is subject to change. Do not change this parameter unless HP recommends that you do so. If you increase this parameter, you must also increase the ZERO\_LIST\_HI system parameter.

#### **PFRATH (A on Alpha and Integrity servers,D,M)**

PFRATH specifies the page fault rate above which the limit of a working set is automatically increased. The unit of measure is the number of faults per 10 seconds of processor time. At a setting of 120, for example, the system automatically increases the limit of a working set if it is faulting more than 120 pages per 10 seconds. Decreasing the value of this parameter tends to increase the limits of the working sets, while increasing its value tends to decrease their limits.

On Alpha and Integrity servers, the default value is 8 page faults every 10 seconds.

#### **PFRATL (A,D,M)**

PFRATL specifies the page fault rate below which the limit of a working set is automatically decreased. The unit of measure is the number of faults per 10 seconds of processor time. At a setting of 1, for example, the system automatically decreases the limit of a working set if it is faulting less than 1 page every 10 seconds.

Increasing the value of this parameter tends to decrease the limits of the working sets, while decreasing its value tends to increase their limits.

#### **PHYSICAL\_MEMORY (A)**

(Alpha and Integrity servers) PHYSICAL\_MEMORY specifies the amount of physical memory available for use. The default setting is -1, which equates to all memory in the system. Decreasing this parameter allows you to test smaller configurations of memory without having to remove memory boards.

This special parameter is used by HP and is subject to change. Do not change this parameter unless HP recommends that you do so.

Because of hardware configuration requirements on the AlphaServer ES47/ES80/GS1280 systems, HP does not recommend altering the setting of the system parameter PHYSICAL\_MEMORY from its default setting of -1. Artificially reducing the amount of memory can produce unpredictable results on these systems.

## System Parameters

### D.2 Parameter Descriptions

#### **PIOPAGES (A,D)**

PIOPAGES specifies the size of the process I/O segment, which holds data structures and buffer pool space for RMS to use when it handles I/O that involves process-permanent files. Once PIOPAGES is reset in SYSGEN, any new process receives the changed value.

Beginning with OpenVMS Version 7.2, the default value has been raised to 575. The setting has been raised to accommodate the increased demands for process-permanent memory that result from changes made to RMS file-naming parsing in Version 7.2.

This special parameter is used by HP and is subject to change. Do not change this parameter unless HP recommends that you do so.

#### **PIXSCAN (A,D)**

PIXSCAN specifies the number of process index slots scanned each second for computable or computable-outswapped processes. These processes receive an automatic priority boost for 1 quantum, unless the priority of the currently executing process is greater than 15. The priority boost is done to avoid potential deadlocks on the system.

This special parameter is used by HP and is subject to change. Do not change this parameter unless HP recommends that you do so.

#### **POOLCHECK (D)**

This special parameter is used by HP and is subject to change. Do not change this parameter unless HP recommends that you do so.

POOLCHECK is used to investigate frequent and inexplicable failures in a system. When POOLCHECK is enabled, pool-checking routines execute whenever pool is deallocated or allocated.

Two loadable forms of SYSTEM\_PRIMITIVES.EXE are available at boot time. The default image, which contains no pool-checking code and no statistics maintenance, is loaded when POOLCHECK is set to zero. When POOLCHECK is set to a nonzero value, the monitoring version of SYSTEM\_PRIMITIVES.EXE, which contains both pool-checking code and statistics maintenance, is loaded.

Setting the SYSTEM\_CHECK parameter to 1 has the effect of setting POOLCHECK to %X616400FF. For further information about pool checking, see the *OpenVMS VAX Device Support Manual*, (which is archived).

POOLCHECK is a DYNAMIC parameter. However, for a change in its value to have any effect, POOLCHECK must be non-0 at boot time (to load the monitoring version of SYSTEM\_PRIMITIVES.EXE).

#### **POOLPAGING**

POOLPAGING enables ( 1 ) paging of pageable dynamic pool.

This special parameter is used by HP and is subject to change. Do not change this parameter unless HP recommends that you do so.

#### **POWEROFF (D)**

POWEROFF enables or disables software requests to the console firmware to remove power from the system. This parameter should normally be turned ON ( 1 ) to allow software to make power-off requests. However, POWEROFF can be set to OFF ( 0 ) to disable software power-off requests.

If firmware or hardware support for the power-off request is not implemented, the shut-down procedure will leave the system halted but fully powered.



## System Parameters

### D.2 Parameter Descriptions

#### **PQL\_DASTLM (D,G)**

PQL\_DASTLM sets the default limit on the number of pending ASTs for a process created by the Create Process (\$CREPRC) system service or the DCL command RUN (Process).

#### **PQL\_DBIOLM (D,G)**

PQL\_DBIOLM sets the default buffered I/O count limit for the number of outstanding buffered I/O operations permitted to a process created by the Create Process (\$CREPRC) system service or the DCL command RUN (Process).

#### **PQL\_DBYTLM (D,G)**

PQL\_DBYTLM sets the default buffered I/O byte count limit for the amount of buffered space available to a process created by the Create Process (\$CREPRC) system service or the DCL command RUN (Process).

#### **PQL\_DCPULM (D,G)**

PQL\_DCPULM sets the default CPU time limit for a process created by the Create Process (\$CREPRC) system service or the DCL command RUN (Process). PQL\_DCPULM specifies the time limit in increments of 10 milliseconds.

The default value of 0 imposes no limit on CPU time usage and is typically the correct value for this parameter.

#### **PQL\_DDIOLM (D,G)**

PQL\_DDIOLM sets the default direct I/O limit for a process created by the Create Process (\$CREPRC) system service or the DCL command RUN (Process).

#### **PQL\_DENQLM (D,G)**

PQL\_DENQLM sets the default enqueue limit for a process created by the Create Process (\$CREPRC) system service or the DCL command RUN (Process).

#### **PQL\_DFILLM (D,G)**

PQL\_DFILLM sets the default open file limit for a process created by the Create Process (\$CREPRC) system service or the DCL command RUN (Process).

#### **PQL\_DJTQUOTA (D)**

PQL\_DJTQUOTA sets the default job table byte count quota for a process created by the Create Process (\$CREPRC) system service or the DCL command RUN (Process). PQL\_DJTQUOTA specifies the number of bytes of paged pool allocated to the job table. The default value is usually adequate, unless a large number of job logical names or temporary mailboxes are used.

#### **PQL\_DPGFLQUOTA (A on VAX,D,G)**

PQL\_DPGFLQUOTA sets the default page file quota for a process created by the Create Process (\$CREPRC) system service or the DCL command RUN (Process). HP recommends that this parameter not be smaller than the PQL\_DWSEXTENT parameter.

#### **PQL\_DPRCLM (D,G)**

PQL\_DPRCLM sets the default subprocess limit for a process created by the Create Process (\$CREPRC) system service or the DCL command RUN (Process).

#### **PQL\_DTQELM (D,G)**

PQL\_DTQELM sets the default number of timer queue entries for a process created by the Create Process (\$CREPRC) system service or the DCL command RUN (Process).

## System Parameters

### D.2 Parameter Descriptions

#### **PQL\_DWSDEFAULT (A,G)**

PQL\_DWSDEFAULT sets the default working set size for a process created by the Create Process (\$CREPRC) system service or the DCL command RUN (Process).

#### **PQL\_DWSEXTENT (A,D,G)**

PQL\_DWSEXTENT sets the default working set extent for a process created by the Create Process (\$CREPRC) system service or the DCL command RUN (Process).

#### **PQL\_DWSQUOTA (A,D,G)**

PQL\_DWSQUOTA sets the default working set quota for a process created by the Create Process (\$CREPRC) system service or the DCL command RUN (Process).

#### **PQL\_MASTLM (D,G)**

PQL\_MASTLM sets a minimum limit on the number of pending ASTs for a process created by the Create Process (\$CREPRC) system service or the DCL command RUN (Process).

#### **PQL\_MBIOLM (D,G)**

PQL\_MBIOLM sets the minimum buffered I/O limit for a process created by the Create Process (\$CREPRC) system service or the DCL command RUN (Process).

#### **PQL\_MBYTLM (D,G)**

PQL\_MBYTLM sets the minimum buffered I/O byte limit for a process created by the Create Process (\$CREPRC) system service or the DCL command RUN (Process).

#### **PQL\_MCPULM (D,G)**

PQL\_MCPULM sets the minimum CPU time limit in increments of 10 milliseconds for a process created by the Create Process (\$CREPRC) system service or the DCL command RUN (Process).

#### **PQL\_MDIOLM (D,G)**

PQL\_MDIOLM sets the minimum direct I/O limit for a process created by the Create Process (\$CREPRC) system service or the DCL command RUN (Process).

#### **PQL\_MENQLM (D,G)**

PQL\_MENQLM sets the minimum limit on the number of locks that can be queued at one time by a process created by the Create Process (\$CREPRC) system service or the DCL command RUN (Process).

#### **PQL\_MFILLM (D,G)**

PQL\_MFILLM sets the minimum open file limit for a process created by the Create Process (\$CREPRC) system service or the DCL command RUN (Process).

#### **PQL\_MJTQUOTA (D)**

PQL\_MJTQUOTA sets the minimum job table byte count quota for a process created by the Create Process (\$CREPRC) system service or the DCL command RUN (Process).

#### **PQL\_MPGFLQUOTA (A on VAX,D,G)**

On VAX systems, PQL\_MPGFLQUOTA sets the minimum page file quota for a process created by the Create Process (\$CREPRC) system service or the DCL command RUN (Process). HP recommends that this parameter be no smaller than PQL\_MWSEXTENT.

## System Parameters

### D.2 Parameter Descriptions

On Alpha and Integrity servers, PQL\_MPGFLQUOTA sets the minimum pagelet file quota for a process created by the Create Process (\$CREPRC) system service or the DCL command RUN (Process).

#### **PQL\_MPRCLM (D,G)**

PQL\_MPRCLM sets the minimum subprocess limit for a process created by the Create Process (\$CREPRC) system service or the DCL command RUN (Process).

#### **PQL\_MTQELM (D,G)**

PQL\_MTQELM sets the minimum number of timer queue entries for a process created by the Create Process (\$CREPRC) system service or the DCL command RUN (Process).

#### **PQL\_MWSDEFAULT (A,G)**

PQL\_MWSDEFAULT sets the minimum default working set size for a process created by the Create Process (\$CREPRC) system service or the DCL command RUN (Process).

This value overrides a smaller quantity that is set for a user in AUTHORIZE.

#### **PQL\_MWSEXTENT (A,D,G)**

PQL\_MWSEXTENT sets the minimum working set extent for a process created by the Create Process (\$CREPRC) system service or the DCL command RUN (Process).

This value overrides a smaller quantity set for a user in AUTHORIZE.

#### **PQL\_MWSQUOTA (A,D,G)**

PQL\_MWSQUOTA sets the minimum working set quota for a process created by the Create Process (\$CREPRC) system service or the DCL command RUN (Process).

This value overrides a smaller quantity set for a user in AUTHORIZE.

#### **PRCPOLINTERVAL (A on Alpha and Integrity servers,D)**

PRCPOLINTERVAL specifies, in seconds, the polling interval used to look for Systems Communications Services (SCS) applications, such as the connection manager and mass storage control protocol disks, on other nodes. All discovered nodes are polled during each interval.

This parameter trades polling overhead against quick recognition of new systems or servers as they appear.

#### **PRIORITY\_OFFSET**

PRIORITY\_OFFSET specifies the difference in priority required by the scheduler for one process to preempt the current process. A value of 2, for example, means that if the current process is executing at priority 1, a computable process at priority 2 or 3 is not allowed to preempt the current process. However, a priority 4 or higher process can preempt the current process. This mechanism affects only normal priority (0-15) processes. The default value is 0.

This special parameter is used by HP and is subject to change. Do not change this parameter unless HP recommends that you do so.

#### **PROCSECTCNT (A,G)**

PROCSECTCNT sets the number of section descriptors that a process can contain. Each section descriptor increases the fixed portion of the process header by 32 bytes.

## System Parameters

### D.2 Parameter Descriptions

Set a value greater than the maximum number of image sections in any section to be run, as indicated by the linkage memory allocation map for the image.

#### PU\_OPTIONS

PU\_OPTIONS is reserved for HP use only.

#### QDSKINTERVAL

QDSKINTERVAL establishes, in seconds, the disk quorum polling interval. The default value is 3.

#### QDSKVOTES

QDSKVOTES specifies the number of votes contributed by a quorum disk in a cluster.

#### QUANTUM (A on Alpha and Integrity servers,D,M)

QUANTUM defines the following:

- Processor time: maximum amount of processor time a process can receive before control passes to another process of equal priority that is ready to compute
- Balance set residency: minimum amount of service a compute-state process must receive before being swapped out to secondary storage

#### RAD\_SUPPORT (G)

(Alpha only) RAD\_SUPPORT enables RAD-aware code to be executed on systems that support Resource Affinity Domains (RADs); for example, AlphaServer GS160 systems. A RAD is a set of hardware components (CPUs, memory, and I/O) with common access characteristics.

Bits are defined in the RAD\_SUPPORT parameter as follows:

RAD\_SUPPORT (default is 79; bits 0-3 and 6 are set)

```

3  2 2  2 2      1 1
1  8 7  4 3      6 5      8 7      0
+-----+-----+-----+-----+-----+
|00|00| skip|ss|gg|ww|pp|00|00|00|00|0p|df|cr|ae|
+-----+-----+-----+-----+-----+

```

- Bit 0 (e): Enable - Enables RAD support
- Bit 1 (a): Affinity - Enables Soft RAD Affinity (SRA) scheduling  
Also enables the interpretation of the skip bits, 24-27.
- Bit 2 (r): Replicate - Enables system-space code replication
- Bit 3 (c): Copy - Enables copy on soft fault
- Bit 4 (f): Fault - Enables special page fault allocation  
Also enables the interpretation of the allocation bits, 16-23.
- Bit 5 (d): Debug - Reserved to HP
- Bit 6 (p): Pool - Enables per-RAD non-paged pool
- Bits 7-15: - Reserved to HP
- Bits 16-23: - If bit 4 is set, bits 16-23 are interpreted as follows:

## System Parameters

### D.2 Parameter Descriptions

Bits 16,17 (pp): Process = Pagefault on process (non global) pages

Bits 18,19 (ww): Swapper = Swapper's allocation of pages for processes

Bits 20,21 (gg): Global = Pagefault on global pages

Bits 22,23 (ss): System = Pagefault on system space pages

Encodings for pp, ww, gg, ss:

Current (0) - allocate PFNs from the current CPU's RAD

Random (1) - allocate PFNs using the "random" algorithm

Base (2) - allocate PFNs from the operating system's "base" RAD

Home (3) - allocate PFNs from the current process's home RAD

If bits 16-23 are 0, the defaults for pp, ww, gg, ss are interpreted as follows:

Process = home RAD

Swapper = current RAD (also sets home RAD for process)

Global = random RAD

System = base RAD

Bits 24-27: - If bit 1 is set, bits 24-27 are interpreted as a skip count value (power of 2). Example: If bits 24-27 contain a 3, the skip count is 8. If bits 24-27 contain a 5, the skip count is 32. If bits 24-27 are 0, the default of 16 is used as the skip count.

Bits 28-31: - Reserved to HP

For more information about using OpenVMS RAD features, see the *OpenVMS Alpha Galaxy and Partitioning Guide*.

#### **RECNXINTERVAL (A on Alpha and Integrity servers,D)**

RECNXINTERVAL establishes the polling interval, in seconds, during which to attempt reconnection to a remote system.

#### **RESALLOC**

RESALLOC controls whether resource allocation checking is performed. The default value of 0 disables resource allocation checking.

This special parameter is used by HP and is subject to change. Do not change this parameter unless HP recommends that you do so.

#### **RESHASHTBL (A,F,M)**

RESHASHTBL defines the number of entries in the lock management resource name hash table. Each entry requires 4 bytes. A typical tuning goal is to have the RESHASHTBL parameter about four times larger than the total number of resources in use on the system. Managers of systems with memory constraints or systems that are not critically dependent on locking speed could set the table to a smaller size.

#### **RJOBLIM (D)**

RJOBLIM defines the maximum number of remote terminals allowed in the system at any one time.

#### **RMS\_CONPOLICY (D)**

RMS\_CONPOLICY specifies the policy to be used for dealing with high-contention write-shared files. This dynamic parameter can be used to ensure fairness between lock conversions and new lock requests.

## System Parameters

### D.2 Parameter Descriptions

Possible values are the following:

| Value     | Explanation   |
|-----------|---|
| NEVER     | (Default) Never use the higher overhead option to improve fairness for any write-shared files accessed on the system; minimal overhead.               |
| SOMETIMES | Use this option for fairer bucket access (but higher overhead) to any write-shared files with global buffers enabled that are accessed on the system. |
| ALWAYS    | Use this option for fairer bucket access (but higher overhead) to all write-shared files accessed on the system.                                      |

You can set this system parameter with the DCL command `SET RMS_DEFAULT/SYSTEM/CONTENTION_POLICY=value` and display the parameter with the DCL command `SHOW RMS_DEFAULT`.

#### **RMSD\* (D)**

`RMSD1`, `RMSD2`, `RMSD3`, `RMSD4`, `RMSD5`, `RMSD6`, and `RMSD7` are special parameters reserved for HP use.

#### **RMS\_DFLRL (D)**

This special parameter is used by HP and is subject to change. Do not change this parameter unless HP recommends that you do so.

#### **RMS\_DFMBC (A,D)**

`RMS_DFMBC` specifies a default multiblock count only for record I/O operations, where *count* is the number of blocks to be allocated for each I/O buffer.

You can set this system parameter with the DCL command `SET RMS_DEFAULT/SYSTEM` and display the parameter with the `SHOW RMS_DEFAULT` command.

#### **RMS\_DFMBFIDX (A,D)**

`RMS_DFMBFIDX` establishes the default RMS multibuffer count for indexed sequential disk operations. This value defines the number of I/O buffers that RMS allocates for each indexed file. For sequential access, a larger number that allows some of the index buckets to remain in memory can improve performance.

You can set this system parameter with the DCL command `SET RMS_DEFAULT/SYSTEM` and display the parameter with `SHOW RMS_DEFAULT`.

#### **RMS\_DFMBFREL (A,D)**

`RMS_DFMBFREL` establishes the default RMS multibuffer count for relative disk operations. This value defines the number of I/O buffers that RMS allocates for each relative file.

You can set this system parameter with the DCL command `SET RMS_DEFAULT/SYSTEM` and display the parameter with `SHOW RMS_DEFAULT`.

#### **RMS\_DFMBFSDK (A,D)**

`RMS_DFMBFSDK` establishes the default RMS multibuffer count for sequential disk operations. This value defines the number of I/O buffers that RMS allocates for sequential disk files.

## System Parameters

### D.2 Parameter Descriptions

The default value is usually adequate. However, if read-ahead or write-behind operations are used, a larger number improves performance.

You can set this system parameter with the DCL command `SET RMS_DEFAULT/SYSTEM` and display the parameter with `SHOW RMS_DEFAULT`.

#### **RMS\_DFMBFSMT (A,D)**

`RMS_DFMBFSMT` establishes the default RMS multibuffer count for magnetic tape operations. This value defines the number of I/O buffers that RMS allocates for magnetic tape files.

You can set this system parameter with the DCL command `SET RMS_DEFAULT/SYSTEM` and display the parameter with `SHOW RMS_DEFAULT`.

#### **RMS\_DFMBFSUR (A,D)**

`RMS_DFMBFSUR` establishes the default multibuffer count for unit record devices.

You can set this system parameter with the DCL command `SET RMS_DEFAULT/SYSTEM` and display the parameter with `SHOW RMS_DEFAULT`.

#### **RMS\_DFNBC (A,D)**

`RMS_DFNBC` specifies a default block count for network access to remote, sequential, indexed sequential, and relative files.

The network block count value represents the number of blocks that RMS is prepared to allocate for the I/O buffers used to transmit and receive data. The buffer size used for remote file access, however, is the result of a negotiation between RMS and the remote file access listener (FAL). The buffer size chosen is the smaller of the two sizes presented.

Thus, `RMS_DFNBC` places an upper limit on the network buffer size that is used. It also places an upper limit on the largest record that can be transferred to or from a remote file. In other words, the largest record that can be transferred must be less than or equal to `RMS_DFNBC` multiplied by 512 bytes.

You can set this system parameter with the DCL command `SET RMS_DEFAULT/SYSTEM` and display the parameter with `SHOW RMS_DEFAULT`.

#### **RMS\_EXTEND\_SIZE (D)**

`RMS_EXTEND_SIZE` specifies the number of blocks by which files are extended as they are written. This number should be chosen to balance the amount of extra disk space wasted at the ends of each file against the performance improvement provided by making large extents infrequently.

When small disk quotas are used, specify a small number such as the disk cluster size to prevent the user's disk quota from being consumed. If the value of 0 is used, RMS allocates large extents and truncates the file back to its actual usage when it closes.

You can set this system parameter with the DCL command `SET RMS_DEFAULT/SYSTEM` and display the parameter with `SHOW RMS_DEFAULT`.



## System Parameters

### D.2 Parameter Descriptions

#### RMS\_FILEPROT

RMS\_FILEPROT determines the default file protection for system processes such as those that create the error log, operator log, and job controller. It also determines default file protection for processes created by the job controller (all interactive and batch processes).

Because a process always inherits its default file protection from its creator process, RMS\_FILEPROT determines default file protection only for users who do not execute the DCL command SET PROTECTION/DEFAULT in their login command procedures or during interactive sessions.

The protection is expressed as a mask. (See the discussion of the \$CRMPSC system service in the *HP OpenVMS System Services Reference Manual* for more information about specifying protection masks.) By default, the mask is 64000 (decimal) or FA00 (hexadecimal), which represents the following protection:

(S:RWED,O:RWED,G:RE,W:)

#### RMS\_HEURISTIC (D)

This special parameter is used by HP and is subject to change. Do not change this parameter unless HP recommends that you do so.

#### RMS\_PATH\_TMO

The RMS path cache in each process holds entries that translate DVI+DID+name to new DVI+DID. These are used to greatly speed up directory path walks. Cache entries representing ordinary directory lookups are invalidated through the volume directory sequence number mechanism (UDB\$L\_DIRSEQ), which is clocked on every volume dismount and each time a directory is deleted or renamed. However, there is no convenient mechanism for invalidating a cache entry that represents a symlink, whose interpretation is affected by logical names or modification of the symlink. The only way to eliminate stale cache entries is with a timeout. This parameter is the systemwide cache timeout. Special values:

1 = don't keep cache entries -1 = keep cache entries forever

#### RMS\_PROLOGUE (D)

RMS\_PROLOGUE specifies the default prologue RMS uses to create indexed files. The default value 0 specifies that RMS should determine the prologue based on characteristics of the file. A value of 2 specifies Prologue 2 or Prologue 1, and 3 specifies Prologue 3. The RMS prologues are described in the *OpenVMS Record Management Services Reference Manual*.

#### RMS\_SEQFILE\_WBH (D)

(Alpha and Integrity servers) RMS\_SEQFILE\_WBH can enable the RMS writebehind feature as a system default for any unshared sequential disk file if the file is opened for image I/O with write access specified. The possible settings are the following:

| Setting     | Description   |
|-------------|---|
| 0 (default) | Do not enable writebehind feature. Preserve prior behavior of using writebehind only if the user requests it by setting RAB\$V_WBH in RAB\$L_ROP. |
| 1           | Enable writebehind feature as system default, including the allocation of at least two local buffers.   |



### **S0\_PAGING**

S0\_PAGING controls paging of system code:

- Setting bit 0 disables paging of all Exec code and data.
- Setting bit 1 disables paging of all RMS code and data.

This special parameter is used by HP and is subject to change. Do not change this parameter unless HP recommends that you do so.

### **S2\_SIZE**

(Alpha and Integrity servers) S2\_SIZE is the number of megabytes to reserve for S2 space. This value does not include the size required for extended file cache (XFC).

### **SAVEDUMP**

If the dump file is saved in the page file, SAVEDUMP specifies whether the page file is saved until the dump file is analyzed. The default value 0 specifies that the page file should not be retained. A value of 1 specifies that the dump written to the page file should be retained until either copied or released using the SDA utility.

### **SCHED\_FLAGS (D)**

Special DYNAMIC parameter reserved for HP use.

### **SCH\_HARD\_OFFLD (D)**

The scheduler hard off-load parameter is a CPU bitmask parameter. The bits correspond to CPU IDs. For any bit set, the OpenVMS scheduler does not schedule processes on this CPU unless the process has hard affinity set for the CPU. In addition, a process with the PRIMARY capability requirement will ignore the bit corresponding to the primary CPU.

### **SCH\_SOFT\_OFFLD (D)**

The scheduler soft off-load parameter is a CPU bitmask parameter. The bits correspond to CPU IDs. For any bit set, the OpenVMS scheduler tries to avoid scheduling processes on this CPU. However, if no other idle CPUs exist, processes are still scheduled on this CPU.

### **SCSBUFFCNT (A,F,G)**

On VAX systems, SCSBUFFCNT is the number of buffer descriptors configured for all systems communication architecture (SCA). If an SCA device is not configured on your system, this parameter is ignored. Generally speaking, each data transfer needs a buffer descriptor and thus the number of buffer descriptors can be a limit on the number of possible simultaneous I/Os. Various performance monitors report when a system is out of buffer descriptors for a given workload which is an indication that a larger value for SCSBUFFCNT is worth considering. Note that AUTOGEN provides feedback for this parameter on VAX systems only.

On Alpha and Integrity servers, the system communication services (SCS) buffers are allocated as needed, and SCSBUFFCNT is reserved for HP use only.

### **SCSFLOWCUSH (D)**

Specifies the lower limit for receive buffers at which point system communication services (SCS) starts to notify the remote SCS of new receive buffers. For each connection, SCS tracks the number of receive buffers available. SCS communicates this number to the SCS at the remote end of the connection. However, SCS does not need to do this for each new receive buffer added.

## System Parameters

### D.2 Parameter Descriptions

Instead, SCS notifies the remote SCS of new receive buffers if the number of receive buffers falls as low as the SCSFLOWCUSH value.

The default value is adequate on most systems. If a systems communication architecture (SCA) port is not configured on your system, this parameter is ignored.

#### **SCSI\_ERROR\_POLL (D)**

If an error occurs while a particular initiator is accessing a SCSI device, that error is latched for all other initiators and is not unlatched and reported to the other initiators until the next time they access the device. Therefore, if the other initiators do not access the device in a timely manner, the reporting of the error can be greatly delayed, which can cause confusion.

The purpose of SCSI\_ERROR\_POLL is to cause OpenVMS to send a SCSI Test Unit Ready command every hour to each SCSI disk, in an attempt to force latched errors to become unlatched and to be reported immediately. SCSI\_ERROR\_POLL has a default value of 1. It can, however, be set to 0 by the user in order to stop the error polling activity.

The parameter affects SCSI disks connected by Fibre Channel as well as parallel SCSI. If the disk has multiple paths, then the error polling is performed on all non-served paths to the disk. Tapes and other non-disk devices are not subject to this error polling, regardless of the parameter setting.

#### **SCSICLUSTER\_P[1-4]**

(Alpha only) SCSICLUSTER\_P[1-4] parameters allow non-HP peripherals (CPU-lookalikes) in SCSI clusters.

This special parameter is used by HP and is subject to change. Do not change this parameter unless HP recommends that you do so.

#### **SCSMAXDG (G)**

This parameter is reserved for HP use only.

#### **SCSMAXMSG (G)**

This parameter is reserved for HP use only.

#### **SCSNODE (A,G)**

SCSNODE specifies the name of the computer. This parameter is not dynamic.

Specify SCSNODE as a string of up to six characters. Enclose the string in quotation marks.

---

#### **Note**

---

The maximum size of six characters is strictly enforced. SYSBOOT truncates the value of SCSNODE if the size of the system parameter is set to more than six characters.

---

If the computer is in an OpenVMS Cluster, specify a value that is unique within the cluster. Do not specify the null string.

If the computer is running DECnet for OpenVMS, the value must be the same as the DECnet node name.

## System Parameters

### D.2 Parameter Descriptions

#### SCSRESPCNT (A,F,G)

SCSRESPCNT is the total number of response descriptor table entries (RDTEs) configured for use by all system applications.

If SCA or DSA ports are not configured on your system, the system ignores SCSRESPCNT.

#### SCSSYSTEMID (G)

Specifies a number that identifies the computer. This parameter is not dynamic. SCSSYSTEMID is the low-order 32 bits of the 48-bit system identification number.

If the computer is in an OpenVMS Cluster, specify a value that is unique within the cluster. Do not use zero as the value.

If the computer is running DECnet for OpenVMS, calculate the value from the DECnet address using the following formula:

$$\text{SCSSYSTEMID} = ((\text{DECnet area number}) * 1024) + (\text{DECnet node number})$$

**Example:** If the DECnet address is 2.211, calculate the value as follows:

$$\text{SCSSYSTEMID} = (2 * 1024) + 211 = 2259$$

#### SCSSYSTEMIDH (G)

Specifies the high-order 16 bits of the 48-bit system identification number. This parameter must be set to 0. It is reserved by HP for future use.

#### SECURITY\_POLICY

SECURITY\_POLICY allows a system to run in a C2 or B1 configuration and to subset out particular pieces of functionality—to exclude functionality that is outside the evaluated configuration or to preserve compatibility with previous versions of the operating system. See the *HP OpenVMS Guide to System Security* for further information about the C2 and B1 evaluated configurations.

The following bits are defined:

| Bit | Description   |
|-----|---|
| 0   | Obsolete.   |
| 1   | Allows multiple user names to connect to DECW\$SERVER.  |
| 2   | Allows unevaluated DECwindows transports (such as TCP/IP).  |
| 3   | Allows \$SIGPRC and \$PRCTERM to span job trees.  |
| 4   | Allows security profile changes to protected objects on a local node when the object server is absent and cannot update the cluster database VMS\$OBJECTS.DAT.                    |
| 5   | Allows creation of protected objects on a local node when the object server is absent and cannot update the cluster database VMS\$OBJECTS.DAT.                                    |
| 6   | Allows SPAWN or LIB\$SPAWN commands in CAPTIVE accounts.  |
| 7   | Reserved to HP.   |
| 8   | Reserved to HP.   |
| 9   | Disables password synchronizations among ACME agents on a systemwide basis. This is functionally equivalent to the SYS\$SINGLE_SIGNON logical name bit mask value 4 for LOGINOUT. |

## System Parameters

### D.2 Parameter Descriptions

| Bit | Description   |
|-----|---|
| 10  | <p>Allows privileged applications to successfully authenticate a user whose principal name maps to a SYSUAF record that is either expired or whose modal restrictions would otherwise prevent the account from being used.</p> <p>A SYSUAF record that is disabled or password-expired (in the case of traditional OpenVMS authentication) cannot be bypassed in this manner.</p> <p>An application with SECURITY privilege specifies the SYS\$ACM ACME\$M_NOAUTHORIZE function modifier to override authorization checks.</p>  |
| 11  | Allows any record in the SYSUAF file to be mapped using external authentication.  |
| 12  | Allows intrusions on a clusterwide or local basis. (If the bit is cleared, intrusions are clusterwide.)   |
| 13  | Reserved to HP.   |
| 14  | <p>Allows the internal name and backlink of files and directories to be read if the user has either execute or read access to the file or directory. If this bit is clear, read access is required.</p> <p>Setting this bit allows the full POSIX pathname of a file or directory to be displayed when some of the directories in the path are execute-only to the user. This feature is required in the following environments:</p> <ul style="list-style-type: none"> <li>• POSIX pathnames are in use.</li> <li>• The BASH shell or other GNV components are in use.</li> <li>• Applications are using the realpath(), getcwd(), getpwnam(), and related C runtime library functions.</li> </ul> |

The default value of 7 preserves compatibility with existing DECwindows Motif behavior. A value of 0 disables all unevaluated configurations.

#### SETTIME

SETTIME enables (1) or disables (0) solicitation of the time of day each time the system is booted. This parameter should usually be off (0), so that the system sets the time of day at boot time to the value of the processor time-of-day register. You can reset the time after the system is up with the DCL command SET TIME (see the *HP OpenVMS DCL Dictionary*).

#### SHADOW\_D1-D5 (D)

Special DYNAMIC parameters reserved for HP use.

#### SHADOW\_ENABLE

Special parameter reserved for HP use.

#### SHADOWING

SHADOWING loads the host-based volume shadowing driver. See *HP Volume Shadowing for OpenVMS* for more information about setting system parameters for volume shadowing.

Specify one of the following values:

| Value | Description   |
|-------|---|
| 0     | No shadowing is enabled; SHDRIVER is not loaded. This is the default value. |

---

| Value | Description   |
|-------|---|
| 2     | Host-based volume shadowing enabled; SHDRIVER is loaded. Host-based volume shadowing provides shadowing of all disks located on a standalone system or an OpenVMS Cluster system. |

---

#### **SHADOW\_HBMM\_RTC (D)**

(Alpha and Integrity servers) SHADOW\_HBMM\_RTC specifies, in seconds, how frequently each shadow set on this system has its modified block count compared with the reset threshold. If the modified block count exceeds the reset threshold, the bitmap for that shadow set is zeroed. This comparison is performed for all shadow sets mounted on the system that have HBMM bitmaps.

The reset threshold is specified by the RESET\_THRESHOLD keyword in the /POLICY qualifier of the SET SHADOW command.

When the comparison is made, the modified block count might exceed the reset threshold by a small increment or by a much larger amount. The difference depends on the write activity to the volume and on the setting of this parameter.

#### **SHADOW\_MAX\_COPY (A,D)**

The value of SHADOW\_MAX\_COPY controls how many parallel copy threads are allowed on a given node.

Carefully consider the needs of each shadowed node when you set this parameter. Too high a value for SHADOW\_MAX\_COPY can affect performance by allowing too many copy threads to operate in parallel. Too low a value unnecessarily restricts the number of threads your system can effectively handle.

See *HP Volume Shadowing for OpenVMS* for more information about setting system parameters for volume shadowing.

#### **SHADOW\_MAX\_UNIT**

SHADOW\_MAX\_UNIT specifies the maximum number of shadow sets that can exist on a system. The setting **must be equal to or greater than** the number of shadow sets you plan to have on a system. Dismounted shadow sets, unused shadow sets, and shadow sets with no write bitmaps allocated to them are included in the total.

---

**Note**

---

Review this default carefully. The setting **must be equal to or greater than** the number of shadow sets you plan to have on a system. If you attempt to mount more shadow sets than the number specified by SHADOW\_MAX\_UNIT, the MOUNT command will fail. Dismounted shadow sets, unused shadow sets, and shadow sets with no write bitmaps allocated to them are included in the count for SHADOW\_MAX\_UNIT.

---

On Alpha and Integrity servers, the default value for this system parameter is 500, which consumes 24 KB of main memory.

If you do not plan to use Volume Shadowing for OpenVMS, you can change the setting to its minimum of 10 (which consumes 480 bytes of main memory). Setting the default to its minimum frees up 23.5 KB of main memory on an OpenVMS Alpha or Integrity servers and 4.5 KB of main memory on a VAX system. (The maximum value of this parameter is 10,000.)

## System Parameters

### D.2 Parameter Descriptions

This system parameter is not dynamic; that is, a reboot is required when you change the setting.

#### **SHADOW\_MBR\_TMO (D)**

SHADOW\_MBR\_TMO controls the amount of time the system tries to fail over physical members of a shadow set before removing them from the set. The SHADOW\_MBR\_TMO parameter replaces the temporary VMSD3 parameter used in prior releases.

The SHADOW\_MBR\_TMO parameter is valid for use only with Phase II of Volume Shadowing for OpenVMS. You cannot set this parameter for use with Phase I, which is obsolete.

Use the SHADOW\_MBR\_TMO parameter (a word) to specify the number of seconds, in decimal from 1 to 65,535, during which recovery of a repairable shadow set is attempted. If you do not specify a value or if you specify 0, the default delay of 120 seconds is used.

Because SHADOW\_MBR\_TMO is a dynamic parameter, you should use the SYSGEN command WRITE CURRENT to permanently change its value.

#### **SHADOW\_PSM\_RDLY**

When a copy or merge operation is needed on a shadow set that is mounted on more than one system, the shadowing driver attempts to perform the operation on a system that has a local connection to all the shadow set members. Shadowing implements the copy or merge operation by adding a time delay based on the number of shadow set members that are MSCP-served to the system. No delay is added for local members; a system with all locally accessible shadow set members usually performs the copy or merge before a system on which one or more members is served (and therefore is delayed) does.

SHADOW\_PSM\_RDLY allows the system manager to adjust the delay that shadowing adds. By default, the delay is 30 seconds for each MSCP-served shadow set member. The valid range for the specified delay is 0 through 65,535 seconds.

When a shadow set is mounted on a system, the value of SHADOW\_PSM\_RDLY is used as the default shadow set member recovery delay for that shadow set. To modify SHADOW\_PSM\_RDLY for an existing shadow set, see the SET SHADOW/RECOVERY\_OPTIONS=DELAY\_PER\_SERVED\_MEMBER=*n* command in *HP Volume Shadowing for OpenVMS*.

#### **SHADOW\_REC\_DLY (D)**

(Alpha and Integrity servers)

The value of the SHADOW\_REC\_DLY parameter specifies the length of time a system waits before it attempts to manage recovery operations on shadow sets that are mounted on the system. A shadow set is said to need recovery when a merge or copy operation is required on that shadow set.

SHADOW\_REC\_DLY can be used to better predict which systems in an OpenVMS Cluster performs recovery operations. This is done by setting lower values of SHADOW\_REC\_DLY on systems that are preferred to handle recovery operations and higher values of SHADOW\_REC\_DLY on systems that are least preferred to handle recovery operations.

The range of SHADOW\_REC\_DLY is 20 to 65535 seconds. The default value is 20 seconds.



## System Parameters

### D.2 Parameter Descriptions

For more information about controlling which systems perform the merge or copy operations, see *HP Volume Shadowing for OpenVMS*.

#### **SHADOW\_SITE\_ID (D)**

(Alpha and Integrity servers) This parameter allows a system manager to define a site value, which Volume Shadowing uses to determine the best device to perform reads, thereby improving performance.

The system manager can now define the site value to be used for all shadow sets mounted on a system. This parameter is an arbitrary numeric value coordinated by the system manager of disaster tolerant clusters. Reads from devices that have site values matching the shadow set's site value are preferred over reads from devices with different site values. For detailed information, see the description of the \$SET DEVICE/SITE in the *HP OpenVMS DCL Dictionary* and *HP Volume Shadowing for OpenVMS*.

#### **SHADOW\_SYS\_DISK**

A SHADOW\_SYS\_DISK parameter value of 1 enables shadowing of the system disk. A value of 0 disables shadowing of the system disk. The default value is 0.

Also specify a system disk shadow set virtual unit number with the SHADOW\_SYS\_UNIT system parameter, unless the desired system disk unit number is DSA0.

A value of 4096 enables CI-based minimerge. To enable minimerge on a system disk, however, you must enable DOSD by setting the DUMPSTYLE parameter to dump off system disk, as described in the *HP OpenVMS System Manager's Manual*. You can then add the value 4096 to your existing SHADOW\_SYS\_DISK value. For example, if you have SHADOW\_SYS\_DISK set to a value of 1, change it to 4097 to enable minimerge.

#### **SHADOW\_SYS\_TMO**

The SHADOW\_SYS\_TMO parameter has the following two distinct uses:

- At system boot time, when this is the *first* node in the cluster to boot and to create this specific shadow set. If the proposed shadow set is not currently mounted in the cluster, use this parameter to extend the time a booting system waits for all former members of the shadowed system disk to become available.
- Once the system successfully mounts the virtual unit and begins normal operations. In this usage, the SHADOW\_SYS\_TMO parameter controls the time the operating system waits for errant members of a system disk. (Use the SHADOW\_MBR\_TMO parameter to control the time the operating system waits for the errant members of an application disk.)

This parameter applies only to members of the system disk shadow set. All nodes using a particular system disk shadow set should have their SHADOW\_SYS\_TMO parameter set to the same value once normal operations begin.

The default value is 120 seconds. Change this parameter to a higher value if you want the system to wait more than the 120-second default for all members to join the shadow set. You can set the parameter value to 120 through 65,535 seconds.

#### **SHADOW\_SYS\_UNIT**

Use this parameter for Phase II shadowing only. The SHADOW\_SYS\_UNIT parameter is an integer value that contains the virtual unit number of the system disk. The default value is 0. The maximum value allowed is 9999. This parameter is effective only when the SHADOW\_SYS\_DISK parameter has a value

## System Parameters

### D.2 Parameter Descriptions

of 1. This parameter should be set to the same value on all nodes booting off a particular system disk shadow set. See *HP Volume Shadowing for OpenVMS* for more information about setting system parameters for volume shadowing.

#### SHADOW\_SYS\_WAIT

The SHADOW\_SYS\_WAIT parameter extends the time a booting system waits for all current members of a mounted shadowed system disk to become available to *this* node. The shadow set must already be mounted by at least one other cluster node for this parameter to take effect.

The default value is 480 seconds. Change this parameter to a higher value if you want the system to wait more than the 480-second default for all members to join the shadow set. You can set the parameter value to 1 through 65,535 seconds.

#### SMCI\_FLAGS (D)

(Alpha Galaxy platforms only) The SMCI\_FLAGS parameter controls operational aspects of SYS\$PBDRIVER, the Galaxy Shared Memory Cluster Interconnect (SMCI).

Bits in the bit mask are the following:

| Bit | Mask |     | Description  |
|-----|------|-----|--|
| 0   | 0    | 0 = | Do not create local communications channels (SYSGEN default). Local SCS communications are primarily used in test situations and are not needed for normal operations. Not creating local communications saves resources and overhead. |
|     |      | 1 = | Create local communications channels.  |
| 1   | 2    | 0 = | Load SYS\$PBDRIVER if booting into both a Galaxy and a Cluster (SYSGEN Default).   |
|     |      | 1 = | Load SYS\$PBDRIVER if booting into a Galaxy.   |
| 2   | 4    | 0 = | Minimal console output (SYSGEN default).   |
|     |      | 1 = | Full console output; SYS\$PBDRIVER displays console messages when it creates and tears down communications channels.   |

#### SMCI\_PORTS

On systems running OpenVMS Galaxy software, the Shared Memory Cluster Interconnect (SMCI) system parameter SMCI\_PORTS controls initial loading of SYS\$PBDRIVER. This parameter is a bit mask; bits 0 through 25 each represent a controller letter. If bit 0 is set, which is the default setting, PBA<sub>x</sub> is loaded (where *x* represents the Galaxy Partition ID). If bit 1 is set, PBB<sub>x</sub> is loaded, and so on up to bit 25, which causes PBZ<sub>x</sub> to be loaded. For OpenVMS Alpha Version 7.2 and later, HP recommends leaving this parameter at the default value of 1.

Loading additional ports allows multiple paths between Galaxy instances. In the initial release of the Galaxy software, having multiple communications channels is not an advantage because SYS\$PBDRIVER does not support fast path. A future release of OpenVMS will provide Fast Path support for SYS\$PBDRIVER, when multiple CPUs improve throughput by providing multiple communications channels between instances.

#### SMP\_CPU\_BITMAP

This parameter indicates that the corresponding CPU is a bitmap representing up to 1024 CPUs. Each bit set in this bitmap indicates that the corresponding CPU automatically attempts to join the active set in an OpenVMS symmetric



## System Parameters

### D.2 Parameter Descriptions

multiprocessing environment when the instance is booted. A cleared bit indicates that the corresponding CPU is ignored only at boot time; if it is otherwise viable, the CPU can be started at a later time.

SMP\_CPU\_BITMAP defaults to all bits set. (CPU 0 through CPU 1023 are enabled for multiprocessing.) Note that the primary processor is always booted regardless of the setting of the corresponding bit in the CPU bitmap.

To change the value of SMP\_CPU\_BITMAP in SYSBOOT or SYSGEN, specify a list of individual bits or contiguous groups of bits. For example:

```
SYSGEN> SET SMP_CPU_BITMAP 0,5,17-21
```

The command in this example sets bits 0, 5, 17, 18, 19, 20, and 21 in the bitmap and clears all other bits.

This parameter replaces the SMP\_CPUS parameter.

#### **SMP\_LNGSPINWAIT**

SMP\_LNGSPINWAIT establishes, in 10-microsecond intervals, the amount of time a CPU in an SMP system normally waits for access to a shared resource. This process is called spinwaiting.

Generally spinlocks at IPL  $\leq$  8 have long holding times, therefore have their timeout intervals set to SMP\_LNGSPINWAIT to prevent SPINWAIT timeouts in cases of nested acquisition.

A timeout causes a CPUSPINWAIT bugcheck.

The default value is 3000000 (30,000 10-microsecond intervals or 30 second).

#### **SMP\_SANITY\_CNT**

SMP\_SANITY\_CNT establishes, in 10-millisecond intervals, the timeout period for each CPU in a symmetric multiprocessing (SMP) system. Each CPU in an SMP system monitors the sanity timer of one other CPU in the configuration to detect hardware or software failures. If allowed to go undetected, these failures could cause the cluster to hang. A timeout causes a CPUSANITY bugcheck.

The default value is 300 milliseconds (30 10-millisecond intervals).

#### **SMP\_SPINWAIT**

SMP\_SPINWAIT establishes, in 10-microsecond intervals, the amount of time a CPU in an SMP system normally waits for access to a shared resource. This process is called **spinwaiting**.

A timeout causes a CPUSPINWAIT bugcheck.

The default value is 100000 (100,000 10-microsecond intervals or 1 second).

#### **SMP\_TICK\_CNT**

SMP\_TICK\_CNT sets the frequency of sanity timer checks by each CPU in a multiprocessing system.

This special parameter is used by HP and is subject to change. Do not change this parameter unless HP recommends that you do so.

#### **SSI\_ENABLE**

(Integrity servers only) This parameter controls the usage of system service interception. SSI\_ENABLE is turned on by default.

## System Parameters

### D.2 Parameter Descriptions

System Service Interception is a mechanism that allows user specified code to run before, after or instead of the intercepted system service. This mechanism is available on OpenVMS Alpha Version 6.1 and later and OpenVMS Integrity servers Version 8.3 and later, but the parameter SSI\_ENABLE is relevant only on Integrity server systems.

#### SSINHIBIT

SSINHIBIT controls whether system services are inhibited ( 1 ) (on a per-process basis). By default, system services are not inhibited ( 0 ).

This special parameter is used by HP and is subject to change. Do not change this parameter unless HP recommends that you do so.

#### STARTUP\_P1–8

The following table describes possible values of STARTUP\_P1 through \_P8:

| STARTUP Value                        | Description  |
|--------------------------------------|--|
| <b>STARTUP_P1</b>                    | <p>Specifies the type of system boot the system-independent startup procedure is to perform when STARTUP_P1 has one of the following values:</p> <ul style="list-style-type: none"><li>• " "– A full boot is performed.</li><li>• "MIN"– A minimum boot that starts only what is absolutely necessary for the operating system to run.</li></ul>   |
| <b>STARTUP_P2</b>                    | <p>Controls the setting of verification during the execution of the system-independent startup procedure, STARTUP.COM, when STARTUP_P2 has one of the values described in the lists below.</p> <p>STARTUP_P2 can be <i>one</i> of the values shown in the following list:</p> <ul style="list-style-type: none"><li>• F[FALSE], N[O], 0, " "—Verification is not enabled; in other words, NOVERIFY is performed.</li><li>• T[RUE], Y[ES], 1—Verification is enabled; in other words, a SET VERIFY is performed.</li></ul> <p>Alternatively, STARTUP_P2 can be a string containing <i>one or more</i> of the letters shown in the following list:</p> <ul style="list-style-type: none"><li>• C—Display various checkpointing messages during startup.</li><li>• D—Log (or Dump) the output from the startup to a file called SYS\$SPECIFIC:[SYSEXE]STARTUP.LOG.</li><li>• P—DCL verification is enabled for each component file, but not for the startup driver. If both P and V are used, P is ignored.</li><li>• V—Full DCL verification is enabled; same as TRUE.</li></ul> <p>For more information about STARTUP_P2, see the SYSMAN command STARTUP SET OPTIONS.</p> |
| <b>STARTUP_P3</b>                    | <p>Beginning in OpenVMS Version 7.2, if STARTUP_P3 is set to AGEN, the system executes AUTOGEN at the end of the startup sequence.</p>   |
| <b>STARTUP_P4 through STARTUP_P8</b> | <p>Reserved for future use.</p>  |

#### SWP\_PRIO

SWP\_PRIO sets the priority of I/O transfers initiated by the swapper.

## System Parameters

### D.2 Parameter Descriptions

This special parameter is used by HP and is subject to change. Do not change this parameter unless HP recommends that you do so.

#### **SWPFAIL**

SWPFAIL sets the number of consecutive swap failures allowed before the swap schedule algorithm is changed to ignore the swap quantum protection.

This special parameter is used by HP and is subject to change. Do not change this parameter unless HP recommends that you do so.

#### **SWPOUTPGCNT (A on VAX,D)**

This parameter allows the swapper an alternative mechanism before actually performing swaps.

On Alpha and Integrity servers, SWPOUTPGCNT defines the minimum number of pagelets to which the swapper should attempt to reduce a process before swapping it out. The pagelets taken from the process are placed into the free-page list.

#### **SWPRATE**

SWPRATE sets the swapping rate (in 10-millisecond units). This parameter limits the amount of disk bandwidth consumed by swapping.

This special parameter is used by HP and is subject to change. Do not change this parameter unless HP recommends that you do so.

#### **SYSMWCNT (A,G,M)**

SYSMWCNT sets the quota for the size of the system working set, which contains the pageable portions of the system, the paged dynamic pool, RMS, and the resident portion of the system message file.

While a high value takes space away from user working sets, a low value can seriously impair system performance. Appropriate values vary, depending on the level of system use. When the system is running at full load, check the rate of system faults with the MONITOR PAGE command of the Monitor utility. An average system page fault rate of between 0 and 3 page faults per second is desirable. If the system page fault rate is high, and especially if the system seems to be slow, you should increase the value of SYSMWCNT. However, do not set this parameter so high that system page faulting never occurs.

#### **SYSPFC**

SYSPFC sets the number of pages to be read from disk on each system paging operation.

This special parameter is used by HP and is subject to change. Do not change this parameter unless HP recommends that you do so.

#### **SYSSER\_LOGGING (D)**

(Alpha and Integrity servers) A value of 1 for SYSSER\_LOGGING enables logging of system service requests for a process. The default is 1.

#### **SYSTEM\_CHECK**

SYSTEM\_CHECK investigates intermittent system failures by enabling a number of run-time consistency checks on system operation and recording some trace information.

## System Parameters

### D.2 Parameter Descriptions

Enabling `SYSTEM_CHECK` causes the system to behave as if the following system parameter values are set (although the values of the following parameters are not actually changed):

| Parameter                    | Value                   | Description   |
|------------------------------|-------------------------|---|
| <code>BUGCHECKFATAL</code>   | 1                       | Crash the system on nonfatal bugchecks.   |
| <code>POOLCHECK</code>       | <code>%X616400FF</code> | Enable all poolchecking, with an allocated pool pattern of <code>%x61616161 ('aaaa')</code> and deallocated pool pattern of <code>x64646464 ('dddd')</code> . |
| <code>MULTIPROCESSING</code> | 2                       | Enable full synchronization checking.   |

While `SYSTEM_CHECK` is enabled, the previous settings of the `BUGCHECKFATAL` and `MULTIPROCESSING` parameters are ignored. However, setting the parameter `POOLCHECK` to a nonzero value overrides the setting imposed by `SYSTEM_CHECK`.

Setting `SYSTEM_CHECK` creates certain image files that are capable of the additional system monitoring. These image files are located in `SYS$LOADABLE_IMAGES` and can be identified by the suffix `_MON`. For information about the type of data checking performed by `SYSTEM_CHECK`, see the description of the `ACP_DATACHECK` parameter. For information about the performance implications of enabling `SYSTEM_CHECK`, see *OpenVMS Performance Management*.

#### **TAPE\_ALLOCLASS**

`TAPE_ALLOCLASS` determines the tape allocation class for the system. The tape allocation class creates a unique clusterwide device name for multiple access paths to the same tape.

The `TAPE_ALLOCLASS` parameter can also be used to generate a unique clusterwide name for tape devices with identical unit numbers.

#### **TAPE\_MVTIMEOUT (D)**

`TAPE_MVTIMEOUT` is the time in seconds that a mount verification attempt continues on a given magnetic tape volume. If the mount verification does not recover the volume within that time, the I/O operations outstanding to the volume terminate abnormally.

#### **TBSKIPWSL**

`TBSKIPWSL` specifies the maximum number of working set list entries that may be skipped while scanning for a “good” entry to discard. Setting this parameter to 0 disables skipping.

This special parameter is used by HP and is subject to change. Do not change this parameter unless HP recommends that you do so.

#### **TIME\_CONTROL (D)**

This special parameter is used by HP and is subject to change. Do not change this parameter unless HP recommends that you do so.

`TIME_CONTROL` is an SMP bit mask parameter that controls debugging functions. The following bits are defined:

## System Parameters

### D.2 Parameter Descriptions

| Bit                   | Description   |
|-----------------------|---|
| 0                     | Obsolete.   |
| 1 (EXE\$V_SANITY)     | Disables the SMP sanity timer support.                        |
| 2 (EXE\$V_NOSPINWAIT) | Disables the functional behavior of the SMP spinwait support. |

#### TIMEPROMPTWAIT

TIMEPROMPTWAIT defines the number of seconds that you want a processor to wait for the time and date to be entered when a system boot occurs, if the processor's time-of-year clock does not contain a valid time. (The time unit of micro-fortnights is approximated as seconds in the implementation.) If the time specified by TIMEPROMPTWAIT elapses, the system continues the boot operation, and the date and time are set to the last recorded time that the system booted.

---

#### Note

---

HP recommends that you set the correct system time before allowing the system to run, so that all functions using time-stamping (such as the operator log, the error log, accounting records, file creation dates, and file expiration dates) contain correct time values.

---

Depending on the value specified for the TIMEPROMPTWAIT parameter, the system acts in one of the following ways:

- If TIMEPROMPTWAIT is 0, no prompt or wait occurs; the system boots immediately, using the time of the last boot as the system time.
- If TIMEPROMPTWAIT is a positive number less than 32768, one prompt is issued and the value dictates how many seconds you can take to respond with a time. If you do not provide a time before TIMEPROMPTWAIT elapses, the system boots, using the time of the last boot as the system time.
- If TIMEPROMPTWAIT is a number in the range of 32768 through 65535, the prompt for the time is issued at intervals starting with 2 and doubling until 256 seconds is reached. If no response is received, the prompts restart, with the 2-second interval. This prompting process repeats indefinitely, until you specify a time.

#### TIMVCFAIL (D)

TIMVCFAIL specifies the time required for an adapter or virtual circuit failure to be detected. HP recommends that the default value be used. HP also recommends that this value be lowered only in OpenVMS Cluster of three CPUs or less, that the same value be used on each computer in the cluster, and that dedicated LAN segments be used for cluster I/O.

#### TMSCP\_LOAD (A)

TMSCP\_LOAD allows the loading of the tape mass storage control protocol server software. The TMSCP\_LOAD parameter also sets locally connected tapes served. For information about setting the TMSCP\_LOAD parameter, see *HP OpenVMS Cluster Systems*.

## System Parameters

### D.2 Parameter Descriptions

Setting `TMSCP_LOAD` to 0 inhibits the loading of the tape server and the serving of local tapes. Setting `TMSCP` to 1 loads the tape server into memory at the time the system is booted and makes all directly connected tape drives available clusterwide. The following table describes the two states of the `TMSCP_LOAD` parameter:

| State | Function   |
|-------|--|
| 0     | Do not load the TMSCP tape server. Do not serve any local tape devices clusterwide. This is the default value. |
| 1     | Load the TMSCP tape server. Serve all local TMSCP tape devices clusterwide.                                    |

#### TMSCP\_SERVE\_ALL

`TMSCP_SERVE_ALL` is a bit mask that controls the serving of tapes. The settings take effect when the system boots. You cannot change the settings when the system is running.

Starting with OpenVMS Version 7.2, the serving types are implemented as a bit mask. To specify the type of serving your system will perform, locate the type you want in the following table and specify its value. For some systems, you may want to specify two serving types, such as serving all tapes except those whose allocation class does not match. To specify such a combination, add the values of each type, and specify the sum.

In a mixed-version cluster that includes any systems running OpenVMS Version 7.1-*x* or earlier, serving all available tapes is restricted to serving all tapes except those whose allocation class does not match the system's allocation class (pre-Version 7.2 meaning). To specify this type of serving, use the value 9, which sets bit 0 and bit 3. The following table describes the serving type controlled by each bit and its decimal value:

| Bit   | Value When Set | Description   |
|-------|----------------|---|
| Bit 0 | 1              | Serve all available tapes (locally attached and those connected to HSx and DSSI controllers). Tapes with allocation classes that differ from the system's allocation class (set by the <code>ALLOCLASS</code> parameter) are also served if bit 3 is not set.   |
| Bit 1 | 2              | Serve locally attached (non-HSx and non-DSSI) tapes.  |
| Bit 2 | N/A            | Reserved.   |
| Bit 3 | 8              | Restrict the serving specified by bit 0. All tapes except those with allocation classes that differ from the system's allocation class (set by the <code>ALLOCLASS</code> parameter) are served.<br><br>This is pre-Version 7.2 behavior. If your cluster includes systems running OpenVMS Version 7.1- <i>x</i> or earlier, and you want to serve all available tapes, you must specify 9, the result of setting this bit and bit 0. |

Although the serving types are now implemented as a bit mask, the values of 0, 1, and 2, specified by bit 0 and bit 1, retain their original meanings:

- 0 — Do not serve any tapes (the default for earlier versions of OpenVMS).
- 1 — Serve all available tapes.
- 2 — Serve only locally attached (non-HSx and non-DSSI) tapes.

If the `TMSCP_LOAD` system parameter is 0, `TMSCP_SERVE_ALL` is ignored.

## System Parameters

### D.2 Parameter Descriptions

#### TTY\_ALTALARM

TTY\_ALTALARM sets the size of the alternate type-ahead buffer alarm. This value indicates at what point an XOFF should be sent to terminals that use the alternate type-ahead buffers with the size specified by the TTY\_ALTYPAHD parameter.

#### TTY\_ALTYPAHD

TTY\_ALTYPAHD sets the size of the alternate type-ahead buffer. Use this parameter to allow the block mode terminals and communications lines to operate more efficiently.

The default value is usually adequate. Do not exceed the maximum value of 32767 when setting this parameter.

#### TTY\_AUTOCHAR (D)

TTY\_AUTOCHAR sets the character the terminal driver echoes when the job controller has been notified.

#### TTY\_BUF

TTY\_BUF sets the default line width for terminals.

#### TTY\_CLASSNAME

TTY\_CLASSNAME provides the 2-character prefix for the terminal class driver name that is required when booting. Changing the prefix can be useful when debugging a new terminal driver.

#### TTY\_DEFCHAR

TTY\_DEFCHAR sets the default characteristics for terminals, using a code derived by summing the following hexadecimal values:

| Characteristic           | Value (Hex) | Function                        |
|--------------------------|-------------|---------------------------------|
| PASSALL                  | 1           | Passall.                        |
| NOECHO                   | 2           | Noecho mode.                    |
| NOTYPEAHEAD <sup>1</sup> | 4           | No type-ahead buffer.           |
| ESCAPE                   | 8           | Escape sequence processing.     |
| HOSTSYNC                 | 10          | Host can send XON and XOFF.     |
| TTSYNC                   | 20          | Terminal can send XON and XOFF. |
| SCRIPT                   | 40          | Internal use only.              |
| LOWER                    | 80          | Lowercase.                      |
| MECHTAB                  | 100         | Mechanical tabs.                |
| WRAP                     | 200         | Wraparound at end of line.      |
| CRFILL <sup>1</sup>      | 400         | Perform carriage return fill.   |
| LFFILL <sup>1</sup>      | 800         | Perform line feed fill.         |
| SCOPE                    | 1000        | Terminal is a scope.            |
| REMOTE                   | 2000        | Internal use only.              |
| EIGHTBIT                 | 8000        | Eight-bit terminal.             |
| MBXDSABL                 | 10000       | Disable mailbox.                |

<sup>1</sup>Do not set this characteristic as the default in TTY\_DEFCHAR.



## System Parameters

### D.2 Parameter Descriptions

| Characteristic | Value (Hex) | Function                       |
|----------------|-------------|--------------------------------|
| NOBRDCST       | 20000       | Prohibit broadcast.            |
| READSYNC       | 40000       | XON and XOFF on reads.         |
| MECHFORM       | 80000       | Mechanical form feeds.         |
| HALFDUP        | 100000      | Set for half-duplex operation. |
| MODEM          | 200000      | Set for modem signals.         |
| PAGE           | FF000000    | Page size. Default is 24.      |

Where a condition is false, the value is 0.

The upper byte is the page length. The default characteristics are 24 lines per page, terminal synchronization, wraparound, lowercase, scope, and full-duplex.

#### TTY\_DEFCHAR2

TTY\_DEFCHAR2 sets a second longword of default terminal characteristics. The default characteristics are represented as a code that is derived by summing the following hexadecimal values:

| Characteristic | Value (Hex) | Function  |
|----------------|-------------|---|
| LOCALECHO      | 1           | Enable local echo terminal logic; use with the TTY_DEFCHAR NOECHO characteristic. |
| AUTOBAUD       | 2           | Enable autobaud detection.  |
| HANGUP         | 4           | Hang up on logout.  |
| MODHANGUP      | 8           | Allow modification of HANGUP without privileges.                                  |
| BRDCSTMBX      | 10          | Allow sending of broadcasts to mailboxes.   |
| XON            | 20          | (No effect in this parameter.)  |
| DMA            | 40          | (No effect in this parameter.)  |
| ALTYPEAHD      | 80          | Use the alternate type-ahead parameters.  |
| SETSPEED       | 100         | Clear to allow setting of speed without privileges.                               |
| DCL_MAILBX     | 200         | Function reserved for HP use only.  |
| DECCRT4        | 400         | Terminal is DIGITAL CRT Level 4.  |
| COMMSYNC       | 800         | Enable flow control using modem signals.  |
| EDITING        | 1000        | Line editing allowed.   |
| INSERT         | 2000        | Sets default mode for insert.   |
| FALLBACK       | 4000        | Do not set this bit with SYSGEN.  |
| DIALUP         | 8000        | Terminal is a dialup line.  |
| SECURE         | 10000       | Guarantees that no process is connected to terminal after Break key is pressed.   |
| DISCONNECT     | 20000       | Allows terminal disconnect when a hangup occurs.                                  |



## System Parameters

### D.2 Parameter Descriptions

| Characteristic | Value (Hex) | Function  |
|----------------|-------------|---|
| PASTHRU        | 40000       | Terminal is in PASTHRU mode.                                  |
| SYSPWD         | 80000       | Log in with system password only.                             |
| SIXEL          | 100000      | Sixel graphics.   |
| DRCS           | 200000      | Terminal supports loadable character fonts.                   |
| PRINTER        | 400000      | Terminal has printer port.                                    |
| APP_KEYPAD     | 800000      | Notifies application programs of state to set keypad on exit. |
| ANSICRT        | 1000000     | Terminal conforms to ANSI CRT programming standards.          |
| REGIS          | 2000000     | Terminal has REGIS CRT capabilities.                          |
| BLOCK          | 4000000     | Block mode terminal.  |
| AVO            | 8000000     | Terminal has advanced video.                                  |
| EDIT           | 10000000    | Terminal has local edit capabilities.                         |
| DECCRT         | 20000000    | Terminal is a DIGITAL CRT.                                    |
| DECCRT2        | 40000000    | Terminal is a DIGITAL CRT Level 2.                            |
| DECCRT3        | 80000000    | Terminal is a DIGITAL CRT Level 3.                            |

The defaults are AUTOBAUD and EDITING.

#### TTY\_DEFCHAR3

(Alpha and Integrity servers) TTY\_DEFCHAR3 allows a user to set a bit so that the OpenVMS terminal driver remaps CTRL/H to Delete. HP recommends that you *not* set this bit as a systemwide default.

| Characteristic | Value (Hex) | Function  |
|----------------|-------------|---|
| TT3\$M_BS      | 10          | When this bit is set, the OpenVMS terminal console remaps CTRL/H to Delete. |

For more information, see the SET TERM and SHOW TERM commands in the *HP OpenVMS DCL Dictionary*.

#### TTY\_DEFPORT

TTY\_DEFPORT provides flag bits for port drivers. Bit 0 set to 1 indicates that the terminal controller does not provide automatic XON/XOFF flow control. This bit should not be set for HP controllers, but it is needed for some foreign controllers. Currently only the YCDRIVER (DMF32, DMZ32) uses this bit. The remaining bits are reserved for future use. This special parameter should be modified only if recommended by HP.

#### TTY\_DIALTYPE

TTY\_DIALTYPE provides flag bits for dialups. Bit 0 is 1 for United Kingdom dialups and 0 for all others. Bit 1 controls the modem protocol used. Bit 2 controls whether a modem line hangs up 30 seconds after seeing CARRIER if a channel is not assigned to the device. The remaining bits are reserved for future use. See the *OpenVMS I/O User's Reference Manual* for more information about flag bits.

## System Parameters

### D.2 Parameter Descriptions

#### **TTY\_DMASIZE (D)**

TTY\_DMASIZE specifies a number of characters in the output buffer. Below this number, character transfers are performed; above this number, DMA transfers occur if the controller is capable of DMA I/O.

#### **TTY\_PARITY**

TTY\_PARITY sets terminal default parity.

#### **TTY\_RSPEED**

TTY\_RSPEED defines the receive speed for terminals. If TTY\_RSPEED is 0, TTY\_SPEED controls both the transmit and the receive speed. Maximum value is 20. This parameter is only applicable for controllers that support split-speed operations, such as the DZ32 and the DMF32.

#### **TTY\_SCANDELTA**

TTY\_SCANDELTA sets the interval for polling terminals for dialup and hangup events. Shorter intervals use more processor time; longer intervals may result in missing a hangup event.

#### **TTY\_SILOTIME**

TTY\_SILOTIME defines the interval at which the DMF32 hardware polls the input silo for received characters. The DMF32 asynchronous terminal controller can delay the generation of a single input interrupt until multiple characters have accumulated in the input silo. TTY\_SILOTIME specifies the number of milliseconds that the characters are allowed to accumulate prior to the generation of an input interrupt by the hardware.

---

#### **Note**

---

The remainder of this discussion is of interest to customers who use Digi Edgeport hardware.

---

TTY\_SILOTIME controls latency, trading throughput and system overhead for latency. The default value for TTY\_SILOTIME is 8. This value is multiplied by 100 and is used as a count of the number of times to send a query to the device for more data after a character transmit or receive is performed.

If no input (or no subsequent output) is seen after 800 responses to the query, the driver stops sending queries to the device and waits for an input interrupt. Reducing the TTY\_SILOTIME value allows the device to buffer more data, with slightly higher latency.

Increasing the value of TTY\_SILOTIME makes the device more sensitive to latency but decreases buffering and overall throughput; it also adds more system and USB overhead. Setting TTY\_SILOTIME to zero causes the driver to send input queries to the device continually. This setting causes the lowest latency, the highest system overhead, and the lowest throughput possible.

#### **TTY\_SPEED**

TTY\_SPEED sets the systemwide default speed for terminals. Low byte is transmit speed, and high byte is receive speed. If high byte is set to 0, receive speed is identical to transmit speed. Maximum value is 20. Baud rates are defined by the \$TTDEF macro.

**TTY\_TIMEOUT (D)**

TTY\_TIMEOUT sets the number of seconds before a process associated with a disconnected terminal is deleted. The default value (900 seconds) is usually adequate. Note that using values for TTY\_TIMEOUT greater than one year (value %X01E13380) can cause overflow errors and result in a disconnected device timing out immediately.

**TTY\_TYPAHDSZ**

TTY\_TYPAHDSZ sets the size of the terminal type-ahead buffer. The default value is usually adequate. Do not exceed the maximum value of 32767 when setting this parameter.

**UAFALTERNATE (G,M)**

UAFALTERNATE enables or disables the assignment of SYSUAF as the logical name for SYSUAFALT, causing all references to the user authorization file (SYSUAF) to be translated to SYS\$SYSTEM:SYSUAFALT. Use of the normal user authorization file (SYS\$SYSTEM:SYSUAF) can be restored by deassigning the system logical name SYSUAF. This parameter should be set on (1) only when the system is being used by a restricted set of users. You must create a user authorization file named SYSUAFALT prior to setting UAFALTERNATE to 1.

**USERD1 (D)**

USERD1 is reserved for definition at the user's site. The reserved longword is referenced by the symbol SGN\$GL\_USERD1.

On Alpha and Integrity servers, this symbol is in the SYS\$LOADABLE\_IMAGES:SYS\$BASE\_IMAGE module.

**USERD2 (D)**

USERD2 is reserved for definition at the user's site. The reserved longword is referenced by the symbol SGN\$GL\_USERD2.

On Alpha and Integrity servers, this symbol is in the SYS\$LOADABLE\_IMAGES:SYS\$BASE\_IMAGE module.

**USER3**

USER3 is a parameter that is reserved for definition at the user's site. The reserved longword is referenced by the symbol SGN\$GL\_USER3.

On Alpha and Integrity servers, this symbol is in the SYS\$LOADABLE\_IMAGES:SYS\$BASE\_IMAGE module.

**USER4**

USER4 is a parameter that is reserved for definition at the user's site. The reserved longword is referenced by the symbol SGN\$GL\_USER4.

On Alpha and Integrity servers, this symbol is in the SYS\$LOADABLE\_IMAGES:SYS\$BASE\_IMAGE module.

**VAXCLUSTER (A)**

VAXCLUSTER controls loading of the cluster code. Specify one of the following:

| Value | Description                   |
|-------|-------------------------------|
| 0     | Never form or join a cluster. |

## System Parameters

### D.2 Parameter Descriptions

| Value | Description  |
|-------|--|
| 1     | Base decision of whether to form (or join) a cluster or to operate standalone on the presence of cluster hardware. |
| 2     | Always form or join a cluster.   |

The default value is 1.

#### **VCC\_FLAGS (A)**

(Alpha only) The static system parameter `VCC_FLAGS` enables and disables file system data caching. If caching is enabled, `VCC_FLAGS` controls which file system data cache is loaded during system startup.

| Value | Description   |
|-------|---|
| 0     | Disables file system data caching on the local node and throughout the OpenVMS Cluster.<br><br>In an OpenVMS Cluster, if caching is disabled on any node, none of the other nodes can use the extended file cache or the virtual I/O cache. They can't cache any file data until that node either leaves the cluster or reboots with <code>VCC_FLAGS</code> set to a nonzero value. |
| 1     | Enables file system data caching and selects the Virtual I/O Cache. This is the default for VAX systems.  |
| 2     | Enables file system data caching and selects the extended file cache. This is the default for Alpha systems.  |

#### **Note**

On Integrity servers, the volume caching product (`[SYS$LDR]SYS$VCC.EXE`) is not available. XFC caching is the default caching mechanism. Setting the `VCC_FLAGS` parameter to 1 is equivalent to not loading caching at all or to setting `VCC_FLAGS` to 0.

#### **VCC\_MAXSIZE (A)**

(Alpha and Integrity servers) The static system parameter `VCC_MAXSIZE` controls the size of the virtual I/O cache. `VCC_MAXSIZE`, which specifies the size in blocks, is 3,700,000 by default.

The virtual I/O cache cannot shrink or grow. Its size is fixed at system startup.

To adjust the XFC size, use the `VCC_MAX_CACHE` system parameter.

#### **VCC\_MAX\_CACHE (D)**

(Alpha and Integrity servers) The dynamic system parameter `VCC_MAX_CACHE` controls the maximum size of the extended file cache. It specifies the size in megabytes. By default, `VCC_MAX_CACHE` has a special value of -1 for people who do not want to tune their systems manually; this value means that at system startup, the maximum size of the extended file cache is set to 50 percent of the physical memory on the system.

The extended file cache can automatically shrink and grow, depending on your I/O workload and how much spare memory your system has. As your I/O workload increases, the cache automatically grows, but never to more than the maximum size. When your application needs memory, the cache automatically shrinks.

## System Parameters

### D.2 Parameter Descriptions

The value of `VCC_MAX_CACHE` at system startup sets an upper limit for the maximum size of the extended file cache. You cannot increase the maximum size of `VCC_MAX_CACHE` beyond its value at boot time. For example, if `VCC_MAX_CACHE` is 60 MB at system startup, you can then set `VCC_MAX_CACHE` to 40, which decreases the maximum size to 40 MB. If you then set `VCC_MAX_CACHE` to 80, the maximum size is only increased to 60 MB, the value set at system startup.

Note that `VCC_MAX_CACHE` is a semi-dynamic parameter. If you change its value, you must enter the DCL command `SET CACHE/RESET` for any changes to take effect immediately. Otherwise, it might take much more time for the changes to take effect.

If you are using the reserved memory registry to allocate memory permanently, you must set the `VCC$MIN_CACHE_SIZE` entry in the reserved memory registry to a value less than or equal to `VCC_MAX_CACHE` at system startup time.

For instructions on setting permanent memory allocations for the cache, see the *HP OpenVMS System Manager's Manual*.

#### **VCC\_MAX\_IO\_SIZE (D)**

(Alpha and Integrity servers) The dynamic system parameter `VCC_MAX_IO_SIZE` controls the maximum size of I/O that can be cached by the extended file cache. It specifies the size in blocks. By default, the size is 127 blocks.

Changing the value of `VCC_MAX_IO_SIZE` affects reads and writes to volumes currently mounted on the local node, as well as reads and writes to volumes mounted in the future.

If `VCC_MAX_IO_SIZE` is 0, the extended file cache on the local node cannot cache any reads or writes. However, the system is not prevented from reserving memory for the extended file cache during startup if a `VCC$MIN_CACHE_SIZE` entry is in the reserved memory registry.

#### **VCC\_MAX\_LOCKS**

(Alpha and Integrity servers) `VCC_MAX_LOCKS` is a special parameter reserved for HP use only. Extended file cache will use this parameter in future versions.

#### **VCC\_PAGESIZE**

(Alpha and Integrity servers) `VCC_PAGESIZE` is a special parameter reserved for HP use only. Extended file cache will use this parameter in future versions.

#### **VCC\_READAHEAD (D)**

(Alpha and Integrity servers) The dynamic system parameter `VCC_READAHEAD` controls whether the extended file cache can use read-ahead caching. Read-ahead caching is a technique that improves the performance of applications that read data sequentially.

By default `VCC_READAHEAD` is 1, which means that the extended file cache can use read-ahead caching. The extended file cache detects when a file is being read sequentially in equal-sized I/Os, and fetches data ahead of the current read, so that the next read instruction can be satisfied from cache.

To stop the extended file cache from using read-ahead caching, set `VCC_READAHEAD` to 0.

Changing the value of `VCC_READAHEAD` affects volumes currently mounted on the local node, as well as volumes mounted in the future.

## System Parameters

### D.2 Parameter Descriptions

Readahead I/Os are totally asynchronous from user I/Os and only take place if sufficient system resources are available.

#### VCC\_RSVD

(Alpha and Integrity servers) VCC\_RSVD is a special parameter reserved for HP use only. Extended file cache will use this parameter in future versions.

#### VCC\_WRITEBEHIND

(Alpha and Integrity servers) VCC\_WRITEBEHIND is reserved for HP use only. Extended file cache will use this parameter in future versions.

#### VCC\_WRITE\_DELAY

(Alpha and Integrity servers) VCC\_WRITE\_DELAY is reserved for HP use only.

#### VHPT\_SIZE

(Integrity servers only) VHPT\_SIZE is the number of kilobytes to allocate for the virtual hash page table (VHPT) on each CPU in the system:

- 0 indicates that no VHPT is allocated.
- 1 indicates that OpenVMS is to choose a default size that is appropriate for your system configuration.

If a VHPT is created, the smallest size is 32KB. The VHPT\_SIZE must be a power of 2 KB in size. If the number specified is not a power of 2, OpenVMS chooses a VHPT size to use for your system that is close to the number specified.

If insufficient memory is available during system startup, OpenVMS might choose a smaller size for the VHPT of each CPU.

A summary of possible values for VHPT\_SIZE is in the following table:

| Value    | Description   |
|----------|---|
| 0        | Do not create a VHPT on each CPU.   |
| 1        | (default) OpenVMS chooses a VHPT of an appropriate size for each CPU.   |
| <i>n</i> | Create a VHPT of <i>n</i> KB for each CPU, where <i>n</i> is a power of 2 that is 32 or greater. (The maximum value, however, is platform-dependent.) |

#### VIRTUALPAGECNT (A,G,M)

On VAX systems, VIRTUALPAGECNT sets the maximum number of virtual pages that can be mapped for any one process. A program is allowed to divide its virtual space between the P0 and P1 tables in any proportion.

If you use SYS\$UPDATE:LIBDECOMP.COM to decompress libraries and the VIRTUALPAGECNT setting is low, make sure you set the PGFLQUOTA field in the user authorization file to at least twice the size of the library.

At installation time, AUTOGEN automatically sets an appropriate value for VIRTUALPAGECNT. The value depends on the particular configuration—the type and number of graphics adapters on the system, if any exist. You cannot set VIRTUALPAGECNT below the minimum value required for your graphics configuration.

Because the VIRTUALPAGECNT setting supports hardware address space rather than system memory, do not use the value of VIRTUALPAGECNT that AUTOGEN sets to gauge the size of your page file.



## System Parameters

### D.2 Parameter Descriptions

Starting with OpenVMS Version 7.0, VIRTUALPAGECNT has been an obsolete parameter on Alpha systems. Note, however, that the parameter remains in existence on Alpha and Integrity servers for compatibility purposes and has a default and maximum value of %X7FFFFFFF. SYSBOOT and AUTOGEN enforce this default value.

#### **VMS\***

VMSD1, VMSD2, VMSD3, VMSD4, VMS5, VMS6, VMS7, and VMS8 are special parameters reserved for HP use. VMSD1 through VMSD4 are DYNAMIC.

#### **VOTES (A)**

VOTES establishes the number of votes an OpenVMS Cluster member system contributes to a quorum.

#### **WBM\_MSG\_INT (D)**

WBM\_MSG\_INT is one of three system parameters that are available for managing the update traffic between a master write bitmap and its corresponding local write bitmaps in an OpenVMS Cluster system. The others are WBM\_MSG\_UPPER and WBM\_MSG\_LOWER. These parameters set the interval at which the frequency of sending messages is tested and also set an upper and lower threshold that determine whether the messages are grouped into one SCS message or are sent one by one.

In single-message mode, WBM\_MSG\_INT is the time interval in milliseconds between assessments of the most suitable write bitmap message mode. In single-message mode, the writes issued by each remote node are, by default, sent one by one in individual SCS messages to the node with the master write bitmap. If the writes sent by a remote node reach an upper threshold of messages during a specified interval, single-message mode switches to buffered-message mode.

In buffered-message mode, WBM\_MSG\_INT is the maximum time a message waits before it is sent. In buffered-message mode, the messages are collected for a specified interval and then sent in one SCS message. During periods of increased message traffic, grouping multiple messages to send in one SCS message to the master write bitmap is generally more efficient than sending each message separately.

The minimum value of WBM\_MSG\_INT is 10 milliseconds. The maximum value is -1, which corresponds to the maximum positive value that a longword can represent. The default is 10 milliseconds.

#### **WBM\_MSG\_LOWER (D)**

WBM\_MSG\_LOWER is one of three system parameters that are available for managing the update traffic between a master write bitmap and its corresponding local write bitmaps in an OpenVMS Cluster system. The others are WBM\_MSG\_INT and WBM\_MSG\_UPPER. These parameters set the interval at which the frequency of sending messages is tested and also set an upper and lower threshold that determine whether the messages are grouped into one SCS message or are sent one by one.

WBM\_MSG\_LOWER is the lower threshold for the number of messages sent during the test interval that initiates single-message mode. In single-message mode, the writes issued by each remote node are, by default, sent one by one in individual SCS messages to the node with the master write bitmap. If the writes sent by a remote node reach an upper threshold of messages during a specified interval, single-message mode switches to buffered-message mode.

## System Parameters

### D.2 Parameter Descriptions

The minimum value of `WBM_MSG_LOWER` is 0 messages per interval. The maximum value is -1, which corresponds to the maximum positive value that a longword can represent. The default is 10.

#### **WBM\_MSG\_UPPER (D)**

`WBM_MSG_UPPER` is one of three system parameters that are available for managing the update traffic between a master write bitmap and its corresponding local write bitmaps in an OpenVMS Cluster system. The others are `WBM_MSG_INT` and `WBM_MSG_LOWER`. These parameters set the interval at which the frequency of sending messages is tested and also set an upper and lower threshold that determine whether the messages are grouped into one SCS message or are sent one by one.

`WBM_MSG_UPPER` is the upper threshold for the number of messages sent during the test interval that initiates buffered-message mode. In buffered-message mode, the messages are collected for a specified interval and then sent in one SCS message.

The minimum value of `WBM_MSG_UPPER` is 0 messages per interval. The maximum value is -1, which corresponds to the maximum positive value that a longword can represent. The default is 100 seconds.

#### **WBM\_OPCOM\_LVL (D)**

`WBM_OPCOM_LVL` controls whether write bitmap system messages are sent to the operator console. Possible values are shown in the following table:

| Value | Description  |
|-------|--|
| 0     | Messages are turned off.   |
| 1     | The default; messages are provided when write bitmaps are started, deleted, and renamed, and when the SCS message mode (buffered or single) changes. |
| 2     | All messages for a setting of 1 are provided plus many more.   |

#### **WINDOW\_SYSTEM (D)**

`WINDOW_SYSTEM` specifies the windowing system to be used on a workstation. Specify one of the following values:

| Value | Description  |
|-------|--|
| 1     | Load the DECwindows Motif for OpenVMS workstation environment. |
| 2     | Load the UIS workstation environment.                          |

#### **WLKSYSDSK**

(Alpha and Integrity servers) `WLKSYSDSK` is used by various bootstrap components to determine if the system disk should be treated as though it is write-locked. This parameter is used primarily to allow OpenVMS to boot from a CD.

#### **WPRE\_SIZE (D)**

`WPRE_SIZE` represents the number of pages to be allocated to accommodate WatchPoint Recovery Entries (WPRE) on the Watchpoint Driver.

This special parameter is used by HP and is subject to change. Do not change this parameter unless HP recommends that you do so.



**WPTTE\_SIZE (D)**

WPTTE\_SIZE is the number of entries that the WPDRIVER creates in the WatchPoint Trace Table.

This special parameter is used by HP and is subject to change. Do not change this parameter unless HP recommends that you do so.

**WRITABLESYS**

WRITABLESYS controls whether system code is writable. This parameter is set (value of 1) for debugging purposes only.

This special parameter is used by HP and is subject to change. Do not change this parameter unless HP recommends that you do so.

**WRITESYSPARAMS (D)**

On Alpha and Integrity servers, WRITESYSPARAMS indicates that parameters are modified during SYSBOOT and are written out to ALPHAVMSSYS.PAR by STARTUP.COM.

This special parameter is used by HP and is subject to change. Do not change this parameter unless HP recommends that you do so.

**WSDEC (A,D,M)**

Increasing the value of this parameter tends to increase the speed with which working set limits are decreased when the need arises.

On Alpha and Integrity servers, WSDEC specifies the number of pagelets by which the limit of a working set is automatically decreased at each adjustment interval (which is quantum end). At a setting of 35, for example, the system decreases the limit of a working set by 35 pagelets each time a decrease is required.

**WSINC (A on Alpha and Integrity servers,D,M)**

Decreasing the value of this parameter tends to reduce the speed with which working set limits are increased when the need arises. Normally, you should keep this parameter at a high value because a rapid increase in limit is often critical to performance.

On Alpha and Integrity servers, WSINC specifies the number of pagelets by which the limit of a working set is automatically increased at each adjustment interval (which is quantum end). At a setting of 150, for example, the system increases the limit of a working set by 150 pagelets each time an increase is required. On Alpha and Integrity servers, the default value is 2400 512-byte pagelets (150 8192-byte Alpha and Integrity server pages).

A value of 0 for WSINC disables the automatic adjustment of working set limits for all processes. Limits stay at their base values. You can disable the automatic adjustment of working set limits on a per-process basis by using the DCL command SET WORKING\_SET.

**WSMAX (A,G,M)**

WSMAX sets the maximum number of pages on a systemwide basis for any working set. WSMAX is calculated as a quarter of the first 32 MB plus a sixteenth of the memory from 32 to 256 MB, plus a sixty-fourth of the memory (if any) above 256 MB.

## System Parameters

### D.2 Parameter Descriptions

This is intended to assist managers of systems that host large numbers of users whose working sets are not large. Systems whose user bases consist of a small number of users (or processes) that require large amounts of physical memory (for example, simulations) might need to set `MIN_WS_MAX` to a value that satisfies the requirements of those processes.

#### **XQPCTL2**

`XQPCTL2` controls improved concurrency. The default value of `XQPCTL2` is 1, which turns on improved concurrency. Setting `XQPCTL2` to 0 turns off improved concurrency. This parameter affects local access to the extent and file ID caches.

This special parameter is used by HP and is subject to change. Do not change this parameter unless HP recommends that you do so.

#### **XQPCTLD1**

`XQPCTLD1` controls multithreading, which can be used only by `PATHWORKS` servers. The default value of `XQPCTLD1` is 8, which enables multithreading. Setting `XQPCTLD1` to 0 disables multithreading.

This special parameter is used by HP and is subject to change. Do not change this parameter unless HP recommends that you do so.

#### **ZERO\_LIST\_HI (A,D)**

(Alpha and Integrity servers) `ZERO_LIST_HI` is the maximum number of pages zeroed and put on the zeroed page list. This list is used as a cache of pages containing all zeros, which improves the performance of allocating such pages.

## A

---

### ACCEPT UNIT command

in MSA utility, *Vol 2: M-Z*, 2-3

### Access control

required by ACL editor, *Vol 1: A-L*, 1-2  
with Identifier ACEs, *Vol 1: A-L*, 1-12  
with protection codes, *Vol 1: A-L*, 1-11

### Access control entries

See ACEs

### Access control list editor

See ACL editor

### Access control lists

See ACLs

### Accounting

enabling image-level accounting, *Vol 1: A-L*,  
12-6, 12-21

### ACCOUNTING command, *Vol 1: A-L*, 2-1

### Accounting files

copying records between, *Vol 1: A-L*, 2-7, 2-23  
processing to produce reports, *Vol 1: A-L*, 2-8,  
2-11, 2-32  
record format of, *Vol 1: A-L*, C-1  
types of record in, *Vol 1: A-L*, 2-36

### Accounting reports

brief reports, *Vol 1: A-L*, 2-8  
full reports, *Vol 1: A-L*, 2-11  
summary reports, *Vol 1: A-L*, 2-32

### Accounting utility (ACCOUNTING), *Vol 1: A-L*, 2-1

### ACEs (access control entries), *Vol 1: A-L*, 1-1, 1-3

application-specific, *Vol 1: A-L*, 1-3  
Creator ACEs, *Vol 1: A-L*, 1-8  
Default Protection ACEs, *Vol 1: A-L*, 1-10  
Identifier ACEs, *Vol 1: A-L*, 1-12  
ordering entries in an ACL, *Vol 1: A-L*, 1-1  
relationship to ACLs, *Vol 1: A-L*, 1-1  
security alarm, *Vol 1: A-L*, 1-4  
security audit, *Vol 1: A-L*, 1-6  
Subsystem ACEs, *Vol 1: A-L*, 1-14

### ACL editor, *Vol 1: A-L*, 1-1

ACL qualifiers, *Vol 1: A-L*, 1-16 to 1-21  
/CLASS qualifier, *Vol 1: A-L*, 1-17  
control access to objects, *Vol 1: A-L*, 1-2  
customizing, *Vol 1: A-L*, B-1  
exiting from, *Vol 1: A-L*, 1-2  
file format required, *Vol 1: A-L*, 1-2  
how to use, *Vol 1: A-L*, 1-1

### ACL editor (cont'd)

invoking, *Vol 1: A-L*, 1-1  
/JOURNAL qualifier, *Vol 1: A-L*, 1-18  
keypad editing, *Vol 1: A-L*, A-1  
/MODE qualifier, *Vol 1: A-L*, 1-19  
object ownership, *Vol 1: A-L*, 1-2  
/OBJECT\_TYPE qualifier, *Vol 1: A-L*, 1-20  
privileges required, *Vol 1: A-L*, 1-2  
prompting by, *Vol 1: A-L*, A-1  
/RECOVER qualifier, *Vol 1: A-L*, 1-21  
specifying file type, *Vol 1: A-L*, 1-2  
specifying object class, *Vol 1: A-L*, 1-2, 1-17  
wildcard restriction, *Vol 1: A-L*, 1-2

### ACLs (access control lists)

impact of length on performance, *Vol 1: A-L*,  
1-1  
list of supported object classes, *Vol 1: A-L*, 1-1  
relationship to ACEs, *Vol 1: A-L*, 1-1  
rules for ordering entries, *Vol 1: A-L*, 1-1

### ACL section files, *Vol 1: A-L*, B-1

### ACP system parameters

See also System parameters  
ACP\_BASEPRIO, *Vol 2: M-Z*, D-3  
ACP\_DATACHECK, *Vol 2: M-Z*, D-3  
ACP\_DINDXCACHE, *Vol 2: M-Z*, D-4  
ACP\_DIRCACHE, *Vol 2: M-Z*, D-4  
ACP\_EXTCACHE, *Vol 2: M-Z*, D-4  
ACP\_EXTLIMIT, *Vol 2: M-Z*, D-4  
ACP\_FIDCACHE, *Vol 2: M-Z*, D-4  
ACP\_HDRCACHE, *Vol 2: M-Z*, D-4  
ACP\_MAPCACHE, *Vol 2: M-Z*, D-5  
ACP\_MAXREAD, *Vol 2: M-Z*, D-5  
ACP\_MULTIPLE, *Vol 2: M-Z*, D-5  
ACP\_QUOCACHE, *Vol 2: M-Z*, D-5  
ACP\_REBLDSYSD, *Vol 2: M-Z*, D-5  
ACP\_SHARE, *Vol 2: M-Z*, D-5  
ACP\_SWAPFLGS, *Vol 2: M-Z*, D-5  
ACP\_SYSACC, *Vol 2: M-Z*, D-6  
ACP\_WINDOW, *Vol 2: M-Z*, D-6  
ACP\_WORKSET, *Vol 2: M-Z*, D-6  
ACP\_WRITEBACK, *Vol 2: M-Z*, D-6  
ACP\_XQP\_RES, *Vol 2: M-Z*, D-6

### Actual node name, *Vol 1: A-L*, 14-62

### Actual port name, *Vol 1: A-L*, 14-62

### Actual service name, *Vol 1: A-L*, 14-62

### ADD (Field) command

in Show Cluster utility, *Vol 2: M-Z*, 7-30

**ADD/IDENTIFIER** command  
     in Authorize utility, *Vol 1: A-L*, 5–19  
**ADD/PROXY** command  
     in Authorize utility, *Vol 1: A-L*, 5–21  
**ADD CIRCUITS** command  
     in Show Cluster utility, *Vol 2: M-Z*, 7–21  
**ADD CLUSTER** command  
     in Show Cluster utility, *Vol 2: M-Z*, 7–23  
**ADD** command  
     in Authorize utility, *Vol 1: A-L*, 5–6  
     in Install utility, *Vol 1: A-L*, 12–5  
**ADD CONNECTIONS** command  
     in Show Cluster utility, *Vol 2: M-Z*, 7–25  
**ADD COUNTERS** command  
     in Show Cluster utility, *Vol 2: M-Z*, 7–27  
**ADD CREDITS** command  
     in Show Cluster utility, *Vol 2: M-Z*, 7–29  
**ADD DEVICE** command  
     in UCM, *Vol 2: M-Z*, 10–14  
**ADD ERRORS** command  
     in Show Cluster utility, *Vol 2: M-Z*, 7–30  
**ADD LOCAL\_PORTS** command  
     in Show Cluster utility, *Vol 2: M-Z*, 7–33  
**ADD MEMBERS** command  
     in Show Cluster utility, *Vol 2: M-Z*, 7–35  
**ADD SYSTEMS** command  
     in Show Cluster utility, *Vol 2: M-Z*, 7–36  
**ADD UNIT** command  
     in MSA utility, *Vol 2: M-Z*, 2–4  
     in SAS Utility, *Vol 2: M-Z*, 5–4  
**AFFINITY\_SKIP** system parameter, *Vol 2: M-Z*, D–7  
**AFFINITY\_TIME** system parameter, *Vol 2: M-Z*, D–7  
**AGEN\$FEEDBACK.DAT** file, *Vol 1: A-L*, 6–6  
**AGEN\$FEEDBACK.EXE** file, *Vol 1: A-L*, 6–6  
**AGEN\$PARAMS.REPORT** file, *Vol 1: A-L*, 6–7  
**Alarm ACEs**, *Vol 1: A-L*, 1–4  
     keywords, *Vol 1: A-L*, 1–5  
     specifying access  
         criteria for, *Vol 1: A-L*, 1–5  
         specifying attributes for, *Vol 1: A-L*, 1–4  
**Alarm messages**  
     See Security alarm messages  
**ALF** (automatic login facility)  
     adding records, *Vol 2: M-Z*, 9–10  
     displaying records, *Vol 2: M-Z*, 9–14  
     removing records, *Vol 2: M-Z*, 9–12  
**ALF ADD** command  
     in SYSMAN, *Vol 2: M-Z*, 9–10  
**ALF REMOVE** command  
     in SYSMAN, *Vol 2: M-Z*, 9–12  
**ALF SHOW** command  
     in SYSMAN, *Vol 2: M-Z*, 9–14  
**/ALIAS** qualifier  
     in Backup utility, *Vol 1: A-L*, 7–13  
**ALIGN** command  
     in Monitor utility, *Vol 2: M-Z*, 1–5  
**ALLOCLASS** system parameter, *Vol 2: M-Z*, D–7  
**ALPHAVMSSYS.OLD** file, *Vol 1: A-L*, 6–8  
**ALPHAVMSSYS.PAR** file, *Vol 1: A-L*, 6–8  
**ANALYZE/AUDIT** command, *Vol 1: A-L*, 4–2  
     See also Audit Analysis utility  
     **/BEFORE** qualifier, *Vol 1: A-L*, 4–4  
     **/BINARY** qualifier, *Vol 1: A-L*, 4–5  
     **/BRIEF** qualifier, *Vol 1: A-L*, 4–6  
     **/EVENT\_TYPE** qualifier, *Vol 1: A-L*, 4–7  
     **/FULL** qualifier, *Vol 1: A-L*, 4–9  
     **/IGNORE** qualifier, *Vol 1: A-L*, 4–10  
     **/INTERACTIVE** qualifier, *Vol 1: A-L*, 4–11  
     **/OUTPUT** qualifier, *Vol 1: A-L*, 4–2, 4–12  
     **/PAUSE** qualifier, *Vol 1: A-L*, 4–13  
     **/SELECT** qualifier, *Vol 1: A-L*, 4–14  
     **/SINCE** qualifier, *Vol 1: A-L*, 4–24  
     **/SUMMARY** qualifier, *Vol 1: A-L*, 4–25  
**ANALYZE/DISK\_STRUCTURE**  
     invoking, *Vol 1: A-L*, 3–6  
**ANALYZE/DISK\_STRUCTURE** stages, *Vol 1: A-L*, D–1  
**Analyze/Disk\_Structure** utility (**ANALYZE/DISK\_STRUCTURE**)  
     directing output, *Vol 1: A-L*, 3–4, 3–5, 3–12  
     examining shadow sets, *Vol 1: A-L*, 3–16  
     file recovery, *Vol 1: A-L*, 3–3  
     parameter, *Vol 1: A-L*, 3–5  
     preventing updates to a volume, *Vol 1: A-L*, 3–11  
     qualifiers, *Vol 1: A-L*, 3–6 to 3–20  
         **/HOMEBLOCKS**, *Vol 1: A-L*, 3–9  
         **/[NO]CONFIRM**, *Vol 1: A-L*, 3–8  
         **/[NO]LIST**, *Vol 1: A-L*, 3–10  
         **/[NO]LOCK\_VOLUME**, *Vol 1: A-L*, 3–11  
         **/[NO]OUTPUT**, *Vol 1: A-L*, 3–12  
         **/[NO]READ\_CHECK**, *Vol 1: A-L*, 3–13  
         **/[NO]REPAIR**, *Vol 1: A-L*, 3–15  
         **/RECORD\_ATTRIBUTES**, *Vol 1: A-L*, 3–14  
         **/SHADOW**, *Vol 1: A-L*, 3–16  
         **/STATISTICS**, *Vol 1: A-L*, 3–18  
         **/USAGE**, *Vol 1: A-L*, 3–20  
     repairing disk errors, *Vol 1: A-L*, 3–2, 3–15  
     reporting disk errors, *Vol 1: A-L*, 3–2  
     requirements and limitations, *Vol 1: A-L*, 3–6  
**ANALYZE/ERROR\_LOG/ELV** command, *Vol 1: A-L*, 10–1  
     See also the Error Log Viewer (ELV)  
**ANALYZE PDB** command  
     in PCSI, *Vol 2: M-Z*, 4–4  
**Application port**, *Vol 1: A-L*, 14–10, 14–42, 14–43  
     displaying, *Vol 1: A-L*, 14–60  
     mapping, *Vol 1: A-L*, 14–44

- Application service, *Vol 1: A-L*, 14–10, 14–14, 14–42, 14–46
  - defined, *Vol 1: A-L*, 14–16
  - setting up, *Vol 1: A-L*, 14–42
- /ARB\_SUPPORT
  - qualifier for CREATE command, *Vol 1: A-L*, 12–6, 12–21
- ARB\_SUPPORT system parameter, *Vol 2: M-Z*, D–7
- Arrow keys
  - definition, *Vol 2: M-Z*, 7–69
  - functions of, *Vol 2: M-Z*, C–3
- /ASSIST qualifier
  - in Backup utility, *Vol 1: A-L*, 7–14
- Asterisk (\*)
  - as wildcard character, *Vol 1: A-L*, 7–5
- Asynchronous device
  - LAT application ports for, *Vol 1: A-L*, 14–10, 14–42
- ATTACH command
  - in LATCP, *Vol 1: A-L*, 14–4
  - in SYSMAN, *Vol 2: M-Z*, 9–15
- Attributes
  - Dynamic, *Vol 1: A-L*, 5–19, 5–50, 5–72
  - Holder Hidden, *Vol 1: A-L*, 5–19, 5–50, 5–72
  - Name Hidden, *Vol 1: A-L*, 5–19, 5–50, 5–72
  - No Access, *Vol 1: A-L*, 5–19, 5–50, 5–72
  - Resource, *Vol 1: A-L*, 5–19, 5–50, 5–72
  - specifying identifier characteristics, *Vol 1: A-L*, 1–15
  - Subsystem, *Vol 1: A-L*, 5–19, 5–50, 5–72
- Audit ACEs, *Vol 1: A-L*, 1–6
  - specifying access, *Vol 1: A-L*, 1–7
  - specifying attributes, *Vol 1: A-L*, 1–6
- Audit Analysis utility (ANALYZE/AUDIT), *Vol 1: A-L*, 4–1 to 4–37
  - CONTINUE command, *Vol 1: A-L*, 4–28
  - default input file, *Vol 1: A-L*, 4–2
  - directing output, *Vol 1: A-L*, 4–2
  - DISPLAY command, *Vol 1: A-L*, 4–29
  - displaying current selection criteria, *Vol 1: A-L*, 4–37
  - EXIT command, *Vol 1: A-L*, 4–31
  - exiting from, *Vol 1: A-L*, 4–2, 4–31
  - HELP command, *Vol 1: A-L*, 4–32
  - interactive commands, *Vol 1: A-L*, 4–11, 4–27
  - invoking, *Vol 1: A-L*, 4–2
  - LIST command, *Vol 1: A-L*, 4–33
  - NEXT FILE command, *Vol 1: A-L*, 4–34
  - NEXT RECORD command, *Vol 1: A-L*, 4–35
  - POSITION command, *Vol 1: A-L*, 4–36
  - qualifiers, *Vol 1: A-L*, 4–2
    - selecting by access type, *Vol 1: A-L*, 4–14
    - selecting by account name, *Vol 1: A-L*, 4–14
    - selecting by device name, *Vol 1: A-L*, 4–15
    - selecting by facility, *Vol 1: A-L*, 4–15
    - selecting by identifier, *Vol 1: A-L*, 4–16
    - selecting by identifier holder, *Vol 1: A-L*, 4–16
- Audit Analysis utility (ANALYZE/AUDIT) (cont'd)
  - selecting by image name, *Vol 1: A-L*, 4–17
  - selecting by installation event, *Vol 1: A-L*, 4–17
  - selecting by local proxy account, *Vol 1: A-L*, 4–17
  - selecting by network attribute, *Vol 1: A-L*, 4–21
  - selecting by object, *Vol 1: A-L*, 4–19
  - selecting by parent process, *Vol 1: A-L*, 4–20
  - selecting by privilege, *Vol 1: A-L*, 4–20
  - selecting by process, *Vol 1: A-L*, 4–20
  - selecting by success status, *Vol 1: A-L*, 4–21
  - selecting by system characteristic, *Vol 1: A-L*, 4–22
    - selecting by terminal name, *Vol 1: A-L*, 4–22
    - selecting by user name, *Vol 1: A-L*, 4–22
  - selecting by volume, *Vol 1: A-L*, 4–15, 4–17, 4–18, 4–22
  - SHOW command, *Vol 1: A-L*, 4–37
- Audit data packets
  - See Security audit data packets
- Audit event flags
  - See Security audit event messages
- Audit header packets
  - See Security audit header packets
- Auditing security records
  - See Security audit records
- Audit log files
  - See Security audit log files
- Audit messages
  - See Security audit event messages
- Audit reports
  - See Security audit reports
- AUTHORIZE command
  - See Authorize utility
- Authorized privileges
  - assigning to known images, *Vol 1: A-L*, 12–22
- Authorize utility (AUTHORIZE)
  - ADD/IDENTIFIER command, *Vol 1: A-L*, 5–19
  - ADD/PROXY command, *Vol 1: A-L*, 5–21
  - ADD command, *Vol 1: A-L*, 5–6
  - commands summary (table), *Vol 1: A-L*, 5–5
  - controlling access with identifiers, *Vol 1: A-L*, 1–12
  - COPY command, *Vol 1: A-L*, 5–23
  - CREATE/PROXY command, *Vol 1: A-L*, 5–35
  - CREATE/RIGHTS command, *Vol 1: A-L*, 5–36
  - DEFAULT command, *Vol 1: A-L*, 5–37
  - default password, *Vol 1: A-L*, 5–6
  - DEFAULT record, *Vol 1: A-L*, 5–6
  - EXIT command, *Vol 1: A-L*, 5–49
  - exiting from, *Vol 1: A-L*, 5–3
  - GRANT/IDENTIFIER command, *Vol 1: A-L*, 5–50
  - HELP command, *Vol 1: A-L*, 5–52



## Authorize utility (AUTHORIZE) (cont'd)

- invoking, *Vol 1: A-L, 5-3*
- LIST/IDENTIFIER command, *Vol 1: A-L, 5-56*
- LIST/PROXY command, *Vol 1: A-L, 5-58*
- LIST/RIGHTS command, *Vol 1: A-L, 5-59*
- LIST command, *Vol 1: A-L, 5-54*
- login flags, *Vol 1: A-L, 5-9, 5-26, 5-40, 5-63*
- MODIFY/IDENTIFIER command, *Vol 1: A-L, 5-72*
- MODIFY/PROXY command, *Vol 1: A-L, 5-74*
- MODIFY/SYSTEM\_PASSWORD command, *Vol 1: A-L, 5-76*
- MODIFY command, *Vol 1: A-L, 5-60*
- privileges required, *Vol 1: A-L, 5-1*
- REMOVE/IDENTIFIER command, *Vol 1: A-L, 5-78*
- REMOVE/PROXY command, *Vol 1: A-L, 5-79*
- REMOVE command, *Vol 1: A-L, 5-77*
- RENAME/IDENTIFIER command, *Vol 1: A-L, 5-83*
- RENAME command, *Vol 1: A-L, 5-80*
- restrictions, *Vol 1: A-L, 5-1*
- REVOKE/IDENTIFIER command, *Vol 1: A-L, 5-84*
- SHOW/IDENTIFIER command, *Vol 1: A-L, 5-90*
- SHOW/PROXY command, *Vol 1: A-L, 5-92*
- SHOW/RIGHTS command, *Vol 1: A-L, 5-94*
- SHOW command, *Vol 1: A-L, 5-85*

## Autoconfiguration

- Alpha and Integrity server devices, *Vol 2: M-Z, 9-69*

## AUTOGEN

- NEWPARAMS.DAT file, *Vol 1: A-L, 6-2*

## AUTOGEN.COM command procedure, *Vol 1: A-L, 6-1*

- calculation of parameter values, *Vol 1: A-L, 6-7*
- collection of data, *Vol 1: A-L, 6-6, 6-7*
- displaying page, swap, and dump file size calculations, *Vol 1: A-L, 6-7*
- end phase
  - default, *Vol 1: A-L, 6-10*
  - specifying when invoking, *Vol 1: A-L, 6-10*
- examining calculations of, *Vol 1: A-L, 6-5*
- execution mode
  - specifying when invoking, *Vol 1: A-L, 6-10*
- feedback, *Vol 1: A-L, 6-1, 6-5*
  - collection of, *Vol 1: A-L, 6-6*
  - data file, *Vol 1: A-L, 6-6*
  - parameters affected by, *Vol 1: A-L, 6-6*
- files used by, *Vol 1: A-L, 6-9*
- generation of known image file list (VMSIMAGES.DAT), *Vol 1: A-L, 6-7*
- GENFILES phase, *Vol 1: A-L, 6-8*
- GENPARAMS phase, *Vol 1: A-L, 6-7*
- GETDATA phase, *Vol 1: A-L, 6-7*
- HELP phase, *Vol 1: A-L, 6-9*

## AUTOGEN.COM command procedure (cont'd)

- input files, *Vol 1: A-L, 6-9*
- invoking, *Vol 1: A-L, 6-10*
- operations performed by, *Vol 1: A-L, 6-6*
- output files, *Vol 1: A-L, 6-9*
- parameters to, *Vol 1: A-L, 6-10*
- phases, *Vol 1: A-L, 6-6*
  - specifying when invoking, *Vol 1: A-L, 6-10*
- REBOOT phase, *Vol 1: A-L, 6-8*
- restriction with changing system files sizes, *Vol 1: A-L, 6-8*
- SAVPARAMS phase, *Vol 1: A-L, 6-6*
- SETPARAMS phase, *Vol 1: A-L, 6-8*
- SHUTDOWN phase, *Vol 1: A-L, 6-8*
- start phase
  - default, *Vol 1: A-L, 6-10*
  - specifying when invoking, *Vol 1: A-L, 6-10*
- system parameters affected by feedback, *Vol 1: A-L, 6-6*
- TESTFILES phase, *Vol 1: A-L, 6-7*
  - when to run, *Vol 1: A-L, 6-5*
- AUTOGEN.PAR, *Vol 1: A-L, 6-6, 6-8*
- Automatic login facility
  - See ALF
- AUTO\_DLIGHT\_SAV system parameter, *Vol 2: M-Z, D-7*
- AWSMIN system parameter, *Vol 2: M-Z, D-8*
- AWSTIME system parameter, *Vol 2: M-Z, D-8*

## B

### Backlinks

- directory
  - definition, *Vol 1: A-L, 3-2*

### Backup

- image
  - See Image backup
- incremental
  - See Incremental backup
- standalone
  - See Standalone BACKUP

## BACKUP command, *Vol 1: A-L, 7-3 to 7-107*

- See also Backup utility
- element lists, *Vol 1: A-L, 7-4*
- format, *Vol 1: A-L, 7-3*
- input specifier, *Vol 1: A-L, 7-3*
- output specifier, *Vol 1: A-L, 7-3*
- specifying wildcard characters, *Vol 1: A-L, 7-5*
- types of qualifiers, *Vol 1: A-L, 7-7*
- using with save sets, *Vol 1: A-L, 7-3*

## /BACKUP qualifier

- in Backup utility, *Vol 1: A-L, 7-15*

## BACKUP utility

- /SAVE\_SET qualifier, *Vol 1: A-L, 7-37*
- standalone, *Vol 1: A-L, 7-36*

- Backup utility (BACKUP)
    - command line qualifiers, *Vol 1: A-L, 7-7*
    - command line syntax, *Vol 1: A-L, 7-3*
    - compare operation for, *Vol 1: A-L, 7-25*
    - /DELETE qualifier, *Vol 1: A-L, 7-33*
    - directing output from, *Vol 1: A-L, 7-12*
    - exiting from, *Vol 1: A-L, 7-12*
    - improving the speed of, *Vol 1: A-L, 7-44*
    - invoking, *Vol 1: A-L, 7-12*
    - /IO\_LOAD qualifier, *Vol 1: A-L, 7-62*
    - /JOURNAL qualifier, *Vol 1: A-L, 7-63*
    - limit operation, *Vol 1: A-L, 7-68*
    - list operation, *Vol 1: A-L, 7-18, 7-46, 7-69*
    - qualifiers
      - command, *Vol 1: A-L, 7-7*
      - input file-selection, *Vol 1: A-L, 7-7*
      - input save-set, *Vol 1: A-L, 7-7*
      - output file, *Vol 1: A-L, 7-7*
      - output save-set, *Vol 1: A-L, 7-7*
      - position-dependent, *Vol 1: A-L, 7-8*
    - selective, *Vol 1: A-L, 7-15, 7-16, 7-42, 7-43, 7-73*
    - using to compare files, *Vol 1: A-L, 7-25*
  - BALSETCNT system parameter, *Vol 2: M-Z, D-8*
  - Batch execution
    - on remote nodes, *Vol 2: M-Z, 9-3*
  - /BEFORE qualifier
    - in Backup utility, *Vol 1: A-L, 7-16*
  - /BEGINNING qualifier, *Vol 2: M-Z, 7-13*
    - in Monitor utility, *Vol 2: M-Z, 1-12*
  - Binary output from Audit Analysis utility, *Vol 1: A-L, 4-5*
  - Blocks
    - erasing, *Vol 1: A-L, 3-4*
  - /BLOCK\_SIZE qualifier
    - in Backup utility, *Vol 1: A-L, 7-17*
  - Bootstrap operations, *Vol 2: M-Z, 8-1*
  - BORROWLIM system parameter, *Vol 2: M-Z, D-8*
  - Break-in attempts
    - LAT protocol, *Vol 2: M-Z, D-25*
    - Telnet Protocol, *Vol 2: M-Z, D-25*
  - BREAKPOINTS system parameter, *Vol 2: M-Z, D-9*
  - Brief format listings, *Vol 1: A-L, 4-6*
  - /BRIEF qualifier
    - in Backup utility, *Vol 1: A-L, 7-18*
  - Buffers
    - per-connection
      - allocating, *Vol 2: M-Z, D-9*
  - /BUFFER\_COUNT qualifier
    - in Backup utility, *Vol 1: A-L, 7-19*
  - BUGCHECK
    - dumps System Dump Priority processes early, *Vol 2: M-Z, 9-55*
    - in-memory hardcoded list of priority processes, *Vol 2: M-Z, 9-55*
  - BUGCHECKFATAL system parameter, *Vol 2: M-Z, D-9*
  - BUGREBOOT system parameter, *Vol 2: M-Z, D-9*
  - Buses
    - display on Alpha and Integrity servers, *Vol 2: M-Z, 9-87*
  - /BY\_NODE qualifier
    - in Monitor utility, *Vol 2: M-Z, 1-12*
  - /BY\_OWNER qualifier
    - as Backup utility input file qualifier, *Vol 1: A-L, 7-20*
    - as Backup utility output file qualifier, *Vol 1: A-L, 7-22*
    - as Backup utility output save-set qualifier, *Vol 1: A-L, 7-23*
- ## C
- 
- CDDVD Utility, *Vol 1: A-L, 8-1*
  - Changing page, swap, and dump file sizes, *Vol 1: A-L, 6-1*
  - Changing system parameters
    - recommended method, *Vol 1: A-L, 6-1*
  - CHANNELCNT system parameter, *Vol 2: M-Z, D-9*
  - Checksumming
    - enabling on VCs, *Vol 2: M-Z, 6-21*
  - CHECK\_FEEDBACK mode, *Vol 1: A-L, 6-9*
  - CIRCUITS class
    - adding, *Vol 2: M-Z, 7-21*
    - fields belonging to, *Vol 2: M-Z, 7-1*
    - removing, *Vol 2: M-Z, 7-50*
  - Circuit timer, *Vol 1: A-L, 14-32*
  - Classes
    - SHOW CLUSTER, *Vol 2: M-Z, 7-1*
  - Classname qualifier
    - in Monitor utility
      - /ALL, *Vol 2: M-Z, 1-56*
      - /CPU, *Vol 2: M-Z, 1-42*
      - /ITEM, *Vol 2: M-Z, 1-26, 1-62*
      - /TOPBIO, *Vol 2: M-Z, 1-50*
      - /TOPCPU, *Vol 2: M-Z, 1-50*
      - /TOPDIO, *Vol 2: M-Z, 1-50*
      - /TOPEXECUTIVE, *Vol 2: M-Z, 1-50*
      - /TOPKERNEL, *Vol 2: M-Z, 1-51*
      - /TOPSUPERVISOR, *Vol 2: M-Z, 1-51*
      - /TOPUSER, *Vol 2: M-Z, 1-51*
  - Class scheduler database, *Vol 2: M-Z, 9-18*
  - CLASS\_PROT system parameter, *Vol 2: M-Z, D-9*
  - CLASS\_SCHEDULE ADD command
    - in SYSMAN, *Vol 2: M-Z, 9-17*
  - CLASS\_SCHEDULE commands, *Vol 2: M-Z, 9-17*
    - to 9-27
  - CLASS\_SCHEDULE DELETE command
    - in SYSMAN, *Vol 2: M-Z, 9-22*
  - CLASS\_SCHEDULE MODIFY command
    - in SYSMAN, *Vol 2: M-Z, 9-23*

CLASS\_SCHEDULE RESUME command  
     in SYSMAN, *Vol 2: M-Z*, 9–25  
 CLASS\_SCHEDULE SHOW command  
     in SYSMAN, *Vol 2: M-Z*, 9–26  
 CLASS\_SCHEDULE SUSPEND command  
     in SYSMAN, *Vol 2: M-Z*, 9–27  
 CLEAR DEVICE command  
     in LANCP utility, *Vol 1: A-L*, 13–6  
 CLEAR DLL command  
     in LANCP utility, *Vol 1: A-L*, 13–7  
 CLEAR NODE command  
     in LANCP utility, *Vol 1: A-L*, 13–8  
 CLISYMTBL system parameter, *Vol 2: M-Z*, D–9  
 CLOSE LOG command  
     in LMCP, *Vol 1: A-L*, 15–3  
 CLU\$PARAMS.DAT file, *Vol 1: A-L*, 6–2  
 CLUSTER class  
     adding, *Vol 2: M-Z*, 7–23  
     fields belonging to, *Vol 2: M-Z*, 7–3, 7–31  
     of data, *Vol 2: M-Z*, 7–1  
     removing, *Vol 2: M-Z*, 7–51  
 CLUSTER class record  
     in Monitor utility, *Vol 2: M-Z*, A–11  
 Cluster performance statistics  
     in Monitor utility, *Vol 2: M-Z*, 1–19  
 CLUSTER\_AUTHORIZE.DAT files, *Vol 2: M-Z*,  
     9–28, 9–32  
 CLUSTER\_CONFIG.COM command procedure,  
     *Vol 2: M-Z*, 9–28  
 CLUSTER\_CREDITS system parameter, *Vol 2:*  
     *M-Z*, D–9  
 Command mode for Audit Analysis utility  
     manipulating the display interactively, *Vol 1:*  
     *A-L*, 4–11, 4–27  
 Command procedures  
     building, *Vol 2: M-Z*, 7–62  
     control for SHOW CLUSTER output, *Vol 2:*  
     *M-Z*, 7–11  
     correcting system time, *Vol 2: M-Z*, 9–30  
     executing, *Vol 1: A-L*, 13–4; *Vol 2: M-Z*, 7–20  
     in SYSMAN, *Vol 2: M-Z*, 9–8  
     executing at system startup, *Vol 2: M-Z*, 9–135  
     executing DCL commands with DO, *Vol 2:*  
     *M-Z*, 9–51  
     parameters for, *Vol 1: A-L*, 13–4  
 Commands  
     recalling, *Vol 1: A-L*, 14–27  
 Command summary  
     of Authorize utility commands, *Vol 1: A-L*, 5–4  
 Command syntax, *Vol 1: A-L*, 7–3  
 /COMMENT qualifier  
     in Backup utility, *Vol 1: A-L*, 7–24  
     in Monitor utility, *Vol 2: M-Z*, 1–12  
 Compaction of data  
     See Data compaction  
 Compare operations  
     for BACKUP, *Vol 1: A-L*, 7–25  
 /COMPARE qualifier  
     in Backup utility, *Vol 1: A-L*, 7–25  
 CONCEAL\_DEVICES system parameter, *Vol 2:*  
     *M-Z*, D–10  
 CONFIGURATION SET CLUSTER\_  
     AUTHORIZATION command  
     in SYSMAN, *Vol 2: M-Z*, 9–28  
 CONFIGURATION SET TIME command  
     in SYSMAN, *Vol 2: M-Z*, 9–30  
 CONFIGURATION SHOW CLUSTER\_  
     AUTHORIZATION command  
     in SYSMAN, *Vol 2: M-Z*, 9–32  
 CONFIGURATION SHOW TIME command  
     in SYSMAN, *Vol 2: M-Z*, 9–33  
 Configuration tables  
     rebuilding on Alpha and Integrity servers, *Vol*  
     *2: M-Z*, 9–81, 9–84  
 CONFIGURE command  
     in PCSI, *Vol 2: M-Z*, 4–6  
 Configuring a printer, *Vol 1: A-L*, 14–10  
 /CONFIRM qualifier  
     in Analyze/Disk\_Structure utility, *Vol 1: A-L*,  
     3–8  
     in Backup utility, *Vol 1: A-L*, 7–27  
 CONNECT command  
     in Point-to-Point Protocol utility, *Vol 2: M-Z*,  
     3–3  
 Connecting devices  
     on Alpha and Integrity servers, *Vol 2: M-Z*,  
     9–71  
 Connections  
     in LAT environment, *Vol 1: A-L*, 14–38, 14–65  
     specifying type with LATCP, *Vol 1: A-L*, 14–33  
 CONNECTIONS class  
     adding or restoring, *Vol 2: M-Z*, 7–25  
     fields belonging to, *Vol 2: M-Z*, 7–3  
     removing, *Vol 2: M-Z*, 7–52  
 CONNECT NODE command  
     in LANCP utility, *Vol 1: A-L*, 13–9  
 CONTINUE command  
     in Audit Analysis utility, *Vol 1: A-L*, 4–28  
 /CONTINUOUS qualifier, *Vol 2: M-Z*, 7–14  
 CONVERT command  
     in Monitor utility, *Vol 2: M-Z*, 1–6  
 CONVERT\_DEVICE\_DATABASE command  
     in LANCP utility, *Vol 1: A-L*, 13–11  
 CONVERT LOG command  
     in LMCP, *Vol 1: A-L*, 15–4  
 CONVERT\_NODE\_DATABASE command  
     in LANCP utility, *Vol 1: A-L*, 13–12  
 /CONVERT qualifier  
     in Backup utility, *Vol 1: A-L*, 7–28  
 COPY/RECORDABLE\_MEDIA  
     See CDDVD Utility



COPY/RECORDABLE\_MEDIA command, *Vol 1: A-L*, 8–1

COPY command  
in Authorize utility, *Vol 1: A-L*, 5–23  
in PCSI, *Vol 2: M-Z*, 4–10

Copying a software kit, *Vol 2: M-Z*, 4–10

Counters, *Vol 1: A-L*, 14–1  
displaying  
for links, *Vol 1: A-L*, 14–49  
for nodes, *Vol 1: A-L*, 14–54  
for ports, *Vol 1: A-L*, 14–60  
for services, *Vol 1: A-L*, 14–65  
resetting, *Vol 1: A-L*, 14–69

COUNTERS class  
adding, *Vol 2: M-Z*, 7–27  
fields belonging to, *Vol 2: M-Z*, 7–5  
removing, *Vol 2: M-Z*, 7–54

CPU power  
in LAT environment, *Vol 1: A-L*, 14–33

CPU\_POWER\_MGMT system parameter, *Vol 2: M-Z*, D–10

CPU\_POWER\_THRSH system parameter, *Vol 2: M-Z*, D–10

/CRC qualifier  
as Backup utility input save-set qualifier, *Vol 1: A-L*, 7–29  
as Backup utility output save-set qualifier, *Vol 1: A-L*, 7–30

CRDENABLE system parameter, *Vol 2: M-Z*, D–11

CRD\_CONTROL system parameter, *Vol 2: M-Z*, D–10

CREATE/PROXY command  
in Authorize utility, *Vol 1: A-L*, 5–35

CREATE/RIGHTS command  
in Authorize utility, *Vol 1: A-L*, 5–36

CREATE command  
in Install utility, *Vol 1: A-L*, 12–6  
in SYSGEN, *Vol 2: M-Z*, 8–3

/CREATED qualifier  
in Backup utility, *Vol 1: A-L*, 7–31

CREATE LINK command  
in LATCP, *Vol 1: A-L*, 14–6  
illegal SCSSYSTEMID system parameter, *Vol 1: A-L*, 14–6

CREATE LOG command  
in LMCP, *Vol 1: A-L*, 15–6

CREATE PORT command  
in LATCP, *Vol 1: A-L*, 14–9

CREATE SERVICE command  
in InfoServer utility, *Vol 1: A-L*, 11–3  
in LATCP, *Vol 1: A-L*, 14–14

Creating  
disk usage accounting files, *Vol 1: A-L*, 3–20

Creator ACEs  
specifying access, *Vol 1: A-L*, 1–9  
specifying attributes, *Vol 1: A-L*, 1–8

CREDITS class  
adding, *Vol 2: M-Z*, 7–29  
fields belonging to, *Vol 2: M-Z*, 7–5  
removing, *Vol 2: M-Z*, 7–55

CSR (Control and Status Register)  
addresses  
display on Alpha and Integrity servers, *Vol 2: M-Z*, 9–87

CTLIMGLIM system parameter, *Vol 2: M-Z*, D–11

CTLPAGES system parameter, *Vol 2: M-Z*, D–11

CWCREPRC\_ENABLE system parameter, *Vol 2: M-Z*, D–11

## D

---

Data collection  
by AUTOGEN, *Vol 1: A-L*, 6–7

Data compaction  
TA90E support, *Vol 1: A-L*, 7–72

Data field, *Vol 2: M-Z*, 7–1

Data link  
creating with LATCP, *Vol 1: A-L*, 14–6  
modifying LAT characteristics of, *Vol 1: A-L*, 14–30  
number supported by LAT software, *Vol 1: A-L*, 14–8

/DATA\_FORMAT qualifier  
in Backup utility, *Vol 1: A-L*, 7–32

Dates  
See also SYSMAN command CONFIGURATION SHOW TIME  
displaying in a cluster, *Vol 2: M-Z*, 9–33

DBGTK\_SCRATCH system parameter, *Vol 2: M-Z*, D–11

DCL commands  
in SYSMAN, *Vol 2: M-Z*, 9–52

DCL\_CTLFLAGS system parameter, *Vol 2: M-Z*, D–11

DEADLOCK\_WAIT system parameter, *Vol 2: M-Z*, D–13

DECdtm transaction manager, *Vol 2: M-Z*, A–38

DECnet  
DECNET class record  
in Monitor utility, *Vol 2: M-Z*, A–13  
LAT software  
effect of SCSSYSTEMID system parameter, *Vol 1: A-L*, 14–6

DECservers  
changing device characteristics, *Vol 1: A-L*, 14–9, 14–42

Dedicated port, *Vol 1: A-L*, 14–10, 14–42  
displaying, *Vol 1: A-L*, 14–60

DEFAULT command  
in Authorize utility, *Vol 1: A-L*, 5–37

Default parameter file, *Vol 1: A-L*, 6–8

Default protection  
for NET\$PROXY.DAT, *Vol 1: A-L*, 5–2  
for NETPROXY.DAT, *Vol 1: A-L*, 5–2

Default protection (cont'd)  
 for RIGHTS.LIST.DAT, *Vol 1: A-L*, 5–2  
 for SYSUAF.DAT, *Vol 1: A-L*, 5–2  
 Default Protection ACEs, *Vol 1: A-L*, 1–8, 1–10  
 Default user authorization records  
 modifying, *Vol 1: A-L*, 5–47  
 DEFGID system parameter, *Vol 2: M-Z*, D–13  
 DEFINE/KEY command, *Vol 2: M-Z*, C–3  
 in LATCP, *Vol 1: A-L*, 14–18  
 in Show Cluster utility, *Vol 2: M-Z*, 7–38  
 in SYSMAN, *Vol 2: M-Z*, 9–34  
 DEFINE DEVICE command  
 in LANCP utility, *Vol 1: A-L*, 13–13  
 DEFINE NODE command  
 in LANCP utility, *Vol 1: A-L*, 13–14  
 Defining keys, *Vol 2: M-Z*, 9–34  
 to execute SYSMAN commands, *Vol 2: M-Z*,  
 9–2  
 DEFMBXBUFQUO system parameter, *Vol 2:*  
*M-Z*, D–13  
 DEFMBXMXMSG system parameter, *Vol 2: M-Z*,  
 D–13  
 DEFPRI system parameter, *Vol 2: M-Z*, D–13  
 DEFQUEPRI system parameter, *Vol 2: M-Z*,  
 D–13  
 DEFUID system parameter, *Vol 2: M-Z*, D–13  
 DEINSTALL command  
 in SYSGEN, *Vol 2: M-Z*, 8–4  
 DELETE command  
 in Install utility, *Vol 1: A-L*, 12–11  
 DELETE DEVICE command  
 in UCM, *Vol 2: M-Z*, 10–16  
 DELETE LINK command  
 in LATCP, *Vol 1: A-L*, 14–21  
 DELETE PORT command  
 in LATCP, *Vol 1: A-L*, 14–22  
 /DELETE qualifier  
 in Backup utility, *Vol 1: A-L*, 7–33  
 DELETE QUEUE\_ENTRY command  
 in LATCP, *Vol 1: A-L*, 14–23  
 DELETE RECOVERY\_DATA command  
 in PCSI, *Vol 2: M-Z*, 4–15  
 DELETE SERVICE command  
 in InfoServer utility, *Vol 1: A-L*, 11–7  
 in LATCP, *Vol 1: A-L*, 14–24  
 DELETE UNIT command  
 in MSA utility, *Vol 2: M-Z*, 2–7  
 DELPRC\_EXIT system parameter, *Vol 2: M-Z*,  
 D–14  
 /DENSITY qualifier  
 in Backup utility, *Vol 1: A-L*, 7–34  
 DESELECT command  
 in Show Cluster utility, *Vol 2: M-Z*, 7–41  
 Device addresses  
 See LAN addresses  
 Device drivers  
 displaying on Alpha and Integrity servers, *Vol*  
*2: M-Z*, 9–89  
 Device drivers (cont'd)  
 loading  
 on Alpha and Integrity servers, *Vol 2:*  
*M-Z*, 9–80  
 Device IDs  
 Fibre Channel  
 tape WWIDs, *Vol 2: M-Z*, 9–75, 9–76, 9–82  
 Devices  
 connecting on Alpha and Integrity servers, *Vol*  
*2: M-Z*, 9–69, 9–71  
 displaying  
 default, *Vol 2: M-Z*, 9–125  
 excluding, *Vol 2: M-Z*, 9–85  
 logical name translation, *Vol 2: M-Z*, 9–38  
 SCSI and FC  
 checking for changes in paths, *Vol 2: M-Z*,  
 9–84  
 setting defaults for file specifications, *Vol 2:*  
*M-Z*, 9–121  
 specifying quotas for, *Vol 2: M-Z*, 9–36  
 Device seed, *Vol 1: A-L*, 14–33  
 DEVICE\_NAMING system parameter, *Vol 2:*  
*M-Z*, D–14  
 DIAL\_OUT command  
 in Point-to-Point Protocol utility, *Vol 2: M-Z*,  
 3–4  
 Directing ANALYZE/DISK\_STRUCTURE output,  
*Vol 1: A-L*, 3–6  
 Directing SYSGEN output, *Vol 2: M-Z*, 8–2, 8–9  
 Directories  
 access to files created in, *Vol 1: A-L*, 1–8  
 and Default Protection ACEs, *Vol 1: A-L*, 1–10  
 assigning a Creator ACE to, *Vol 1: A-L*, 1–8  
 creating for a new account, *Vol 1: A-L*, 5–18  
 determining access to files created in, *Vol 1:*  
*A-L*, 1–10  
 ownership  
 changing access to files, *Vol 1: A-L*, 1–8  
 Directory backlinks  
 definition, *Vol 1: A-L*, 3–2  
 Directory default  
 displaying, *Vol 2: M-Z*, 9–125  
 modifying, *Vol 2: M-Z*, 9–121  
 Directory trees  
 propagating UIC-based protection, *Vol 1: A-L*,  
 1–10  
 restoring, *Vol 1: A-L*, 7–7  
 DISABLE command  
 in SYSGEN, *Vol 2: M-Z*, 8–5  
 DISABLE\_UPCALLS system parameter, *Vol 2:*  
*M-Z*, D–14  
 DISCONNECT command  
 in Point-to-Point Protocol utility, *Vol 2: M-Z*,  
 3–6  
 DISK class record  
 in Monitor utility, *Vol 2: M-Z*, A–14

DISKQUOTA ADD command  
in SYSMAN, *Vol 2: M-Z*, 9–36

DISKQUOTA commands, *Vol 2: M-Z*, 9–36 to 9–50

DISKQUOTA CREATE command  
in SYSMAN, *Vol 2: M-Z*, 9–38

DISKQUOTA DELETE command  
See DISKQUOTA REMOVE  
in SYSMAN, *Vol 2: M-Z*, 9–40

DISKQUOTA DISABLE command  
in SYSMAN, *Vol 2: M-Z*, 9–41

DISKQUOTA ENABLE command  
in SYSMAN, *Vol 2: M-Z*, 9–43

DISKQUOTA MODIFY command  
in SYSMAN, *Vol 2: M-Z*, 9–45

DISKQUOTA REBUILD command  
in SYSMAN, *Vol 2: M-Z*, 9–47

DISKQUOTA REMOVE command  
in SYSMAN, *Vol 2: M-Z*, 9–48

Disk quotas  
creating, *Vol 2: M-Z*, 9–38  
disabling, *Vol 2: M-Z*, 9–41  
displaying, *Vol 2: M-Z*, 9–50  
file  
adding entry, *Vol 2: M-Z*, 9–36  
initializing usage count, *Vol 2: M-Z*, 9–36  
modifying an entry, *Vol 2: M-Z*, 9–45  
rebuilding, *Vol 2: M-Z*, 9–47  
removing an entry, *Vol 2: M-Z*, 9–40, 9–48

DISKQUOTA SHOW command  
in SYSMAN, *Vol 2: M-Z*, 9–50

Disk statistics  
in Monitor utility, *Vol 2: M-Z*, 1–26

Disk usage accounting file, *Vol 1: A-L*, E–1  
creating  
example, *Vol 1: A-L*, 3–20

Disk volumes  
repairing errors, *Vol 1: A-L*, 3–15  
verification, *Vol 1: A-L*, 3–1

DISK\_QUORUM system parameter, *Vol 2: M-Z*, D–14

DISMOUMSG system parameter, *Vol 2: M-Z*, D–14

DISPLAY command  
in Audit Analysis utility, *Vol 1: A-L*, 4–29

/DISPLAY qualifier  
in Monitor utility, *Vol 2: M-Z*, 1–12

Displays  
refreshing screen with LATCP, *Vol 1: A-L*, 14–28

Displays from SHOW CLUSTER  
display formatting, *Vol 2: M-Z*, 7–11

Distributed lock management statistics  
in Monitor utility, *Vol 2: M-Z*, 1–29

DKDRIVER, *Vol 1: A-L*, 8–2

DLOCK class record  
in Monitor utility, *Vol 2: M-Z*, A–15

DNVOSI1 system parameter, *Vol 2: M-Z*, D–14

DO command  
in SYSMAN, *Vol 2: M-Z*, 9–51

DORMANTWAIT system parameter, *Vol 2: M-Z*, D–14

DOSD (dump off system disk)  
DUMPSTYLE system parameter, *Vol 2: M-Z*, D–16

DQDRIVER, *Vol 1: A-L*, 8–2

DR\_UNIT\_BASE system parameter, *Vol 2: M-Z*, D–15

Dual-architecture OpenVMS Cluster systems  
installing images  
example, *Vol 2: M-Z*, 9–53

DUMPSYSTEM system parameter, *Vol 2: M-Z*, D–15

DUMP command  
in LMCP, *Vol 1: A-L*, 15–8

Dump files  
changing size, *Vol 1: A-L*, 6–1  
displaying the size calculated by AUTOGEN, *Vol 1: A-L*, 6–7  
generating a new file sized by AUTOGEN, *Vol 1: A-L*, 6–8  
setting priority, *Vol 2: M-Z*, 9–55

DUMPSTYLE system parameter, *Vol 2: M-Z*, D–15

DUMP\_PRIORITY ADD command  
in SYSMAN, *Vol 2: M-Z*, 9–55

DUMP\_PRIORITY LIST command  
in SYSMAN, *Vol 2: M-Z*, 9–58

DUMP\_PRIORITY LOAD command  
in SYSMAN, *Vol 2: M-Z*, 9–59

DUMP\_PRIORITY MODIFY command  
in SYSMAN, *Vol 2: M-Z*, 9–60

DUMP\_PRIORITY REMOVE command  
in SYSMAN, *Vol 2: M-Z*, 9–63

DUMP\_PRIORITY SHOW command  
in SYSMAN, *Vol 2: M-Z*, 9–65

DUMP\_PRIORITY UNLOAD command  
in SYSMAN, *Vol 2: M-Z*, 9–66

Dynamic attributes, *Vol 1: A-L*, 5–19, 5–50, 5–72

Dynamic lock remastering statistics  
in Monitor utility, *Vol 2: M-Z*, 1–56

Dynamic parameters  
modifying, *Vol 2: M-Z*, 8–20, 9–104

Dynamic service rating, *Vol 1: A-L*, 14–15, 14–47  
displaying, *Vol 1: A-L*, 14–58, 14–66

## E

EDIT/ACL command, *Vol 1: A-L*, 1–1  
See also ACL editor

Editing ACLs  
See ACL editor

Editing sessions  
keypad for ACL editing, *Vol 1: A-L*, A–1

EDIT keypad function, *Vol 2: M-Z*, 7–38, C–3  
 EFI Utilities for OpenVMS, *Vol 1: A-L*, 9–3  
     VMS\_BCFG utility, *Vol 1: A-L*, 9–4  
     VMS\_SET utility, *Vol 1: A-L*, 9–6  
     VMS\_SHOW utility, *Vol 1: A-L*, 9–7  
 ENABLE command  
     in SYSGEN, *Vol 2: M-Z*, 8–6  
 Encryption  
     of save sets, *Vol 1: A-L*, 7–36  
 /ENCRYPT qualifier  
     in Backup utility, *Vol 1: A-L*, 7–36  
 /ENDING qualifier, *Vol 2: M-Z*, 7–15  
     in Monitor utility, *Vol 2: M-Z*, 1–13  
 END phase, *Vol 2: M-Z*, 9–142  
 End phase of AUTOGEN, *Vol 1: A-L*, 6–6  
     default, *Vol 1: A-L*, 6–10  
 Environment  
     defining  
         in SYSMAN, *Vol 2: M-Z*, 9–119  
 Erasing blocks, *Vol 1: A-L*, 3–4, 3–9  
 ERLBUFFERPAGES system parameter, *Vol 2: M-Z*, D–17  
 ERLBUFFERPAG\_S2 system parameter, *Vol 2: M-Z*, D–16  
 ERRORLOGBUFFERS system parameter, *Vol 2: M-Z*, D–17  
 ERRORLOGBUFF\_S2 system parameter, *Vol 2: M-Z*, D–17  
 Error Log Viewer (ELV)  
     brief report example, *Vol 1: A-L*, 10–29  
     CONVERT command, *Vol 1: A-L*, 10–4  
         qualifiers, *Vol 1: A-L*, 10–4 to 10–7  
     default report example, *Vol 1: A-L*, 10–29  
     DUMP command, *Vol 1: A-L*, 10–9  
         qualifiers, *Vol 1: A-L*, 10–9 to 10–13  
     event categories, *Vol 1: A-L*, 10–3  
         invalid, *Vol 1: A-L*, 10–3  
         rejected, *Vol 1: A-L*, 10–3  
         selected, *Vol 1: A-L*, 10–3  
         valid, *Vol 1: A-L*, 10–3  
     event classes, *Vol 1: A-L*, 10–17  
     event header information, *Vol 1: A-L*, 10–17  
     EXIT command, *Vol 1: A-L*, 10–14  
     full report example, *Vol 1: A-L*, 10–30  
     HELP command, *Vol 1: A-L*, 10–15  
     interactive shell mode, *Vol 1: A-L*, 10–2  
     invoking, *Vol 1: A-L*, 10–2  
     one-line-per-event report example, *Vol 1: A-L*, 10–28  
     report formats  
         standard, *Vol 1: A-L*, 10–17  
         summary, *Vol 1: A-L*, 10–17  
     standard report detail levels, *Vol 1: A-L*, 10–17  
         brief, *Vol 1: A-L*, 10–17  
         default, *Vol 1: A-L*, 10–17  
         full, *Vol 1: A-L*, 10–17  
         one-line-per-event, *Vol 1: A-L*, 10–17  
     supported event types, *Vol 1: A-L*, 10–1  
 Error Log Viewer (ELV) (cont'd)  
     terse format, *Vol 1: A-L*, 10–30  
     terse report example, *Vol 1: A-L*, 10–30  
     TRANSLATE command, *Vol 1: A-L*, 10–16  
         qualifiers, *Vol 1: A-L*, 10–18 to 10–22  
     WRITE command, *Vol 1: A-L*, 10–23  
         qualifiers, *Vol 1: A-L*, 10–23 to 10–26  
 Errors  
     repair, *Vol 1: A-L*, 3–2, 3–8, 3–9, 3–14, 3–15  
     reporting, *Vol 1: A-L*, 3–2  
 ERRORS class  
     adding, *Vol 2: M-Z*, 7–30  
     fields belonging to, *Vol 2: M-Z*, 7–5  
     removing, *Vol 2: M-Z*, 7–56  
 Ethernet address  
     See LAN addresses  
 Ethernet controllers  
     See LAN controllers  
 Ethernet link  
     See Data link  
 Event classes  
     extracting audit records by, *Vol 1: A-L*, 4–7  
 Event records  
     See Security audit reports  
 Event types, *Vol 1: A-L*, 4–7  
 /EXACT\_ORDER qualifier  
     in Backup utility, *Vol 1: A-L*, 7–39  
 Examples  
     comparing files, *Vol 1: A-L*, 7–26  
     creating a journal file, *Vol 1: A-L*, 7–62, 7–63  
     image save operation, *Vol 1: A-L*, 7–55  
     incremental save operation, *Vol 1: A-L*, 7–57  
     initializing an output disk, *Vol 1: A-L*, 7–59  
     list operation, *Vol 1: A-L*, 7–18  
     of ANALYZE/DISK\_STRUCTURE/SHADOW  
         command, *Vol 1: A-L*, 3–17  
     protecting an output save-set, *Vol 1: A-L*, 7–80  
     repairing errors on a disk volume, *Vol 1: A-L*, 3–15  
     selective backup, *Vol 1: A-L*, 7–15, 7–16  
     specifying a save-set label, *Vol 1: A-L*, 7–67  
     specifying block size, *Vol 1: A-L*, 7–17  
     specifying density for magnetic tape, *Vol 1: A-L*, 7–35  
     specifying redundancy group blocks, *Vol 1: A-L*, 7–48  
     using wildcard characters, *Vol 1: A-L*, 7–6  
 /EXCLUDE qualifier  
     in Backup utility, *Vol 1: A-L*, 7–42  
 Excluding devices, *Vol 2: M-Z*, 9–85  
 Exclusion list  
     displaying, *Vol 2: M-Z*, 9–91  
 EXECSTACKPAGES system parameter, *Vol 2: M-Z*, D–17  
 EXECUTE command  
     in Monitor utility, *Vol 2: M-Z*, 1–7

Execute procedure (@) command  
 in LANCP utility, *Vol 1: A-L, 13–4*  
 in Show Cluster utility, *Vol 2: M-Z, 7–20*  
 to set up SHOW CLUSTER format, *Vol 2: M-Z, 7–20*

Execution modes  
 CHECK\_FEEDBACK, *Vol 1: A-L, 6–9*  
 FEEDBACK, *Vol 1: A-L, 6–9*  
 INITIAL, *Vol 1: A-L, 6–9*  
 NOFEEDBACK, *Vol 1: A-L, 6–9*

EXIT command, *Vol 2: M-Z, 9–67*  
 in Audit Analysis utility, *Vol 1: A-L, 4–31*  
 in Authorize utility, *Vol 1: A-L, 5–49*  
 in InfoServer utility, *Vol 1: A-L, 11–10*  
 in Install utility, *Vol 1: A-L, 12–12*  
 in LANCP utility, *Vol 1: A-L, 13–15*  
 in LATCP, *Vol 1: A-L, 14–25*  
 in Monitor utility, *Vol 2: M-Z, 1–8*  
 in MSA utility, *Vol 2: M-Z, 2–8*  
 in Point-to-Point Protocol utility, *Vol 2: M-Z, 3–7*  
 in Show Cluster utility, *Vol 2: M-Z, 7–42*  
 in SYSGEN, *Vol 2: M-Z, 8–2*  
 in SYSMAN, *Vol 2: M-Z, 9–67*  
 in UCM, *Vol 2: M-Z, 10–17*

EXPECTED\_VOTES system parameter, *Vol 2: M-Z, D–17*

/EXPIRED qualifier  
 in Backup utility, *Vol 1: A-L, 7–43*

Extensible Firmware Interface  
 See EFI utilities for OpenVMS

EXTRACPU system parameter, *Vol 2: M-Z, D–17*

EXTRACT FILE command  
 in PCSI, *Vol 2: M-Z, 4–17*

EXTRACT PDF command  
 in PCSI, *Vol 2: M-Z, 4–21*

EXTRACT PTF command  
 in PCSI, *Vol 2: M-Z, 4–25*

EXTRACT RELEASE\_NOTES command  
 in PCSI, *Vol 2: M-Z, 4–29*

## F

/FAST qualifier  
 in Backup utility, *Vol 1: A-L, 7–44*

FAST\_PATH system parameter, *Vol 2: M-Z, D–17*

FAST\_PATH\_PORTS system parameter, *Vol 2: M-Z, D–17*

FCP class record  
 in Monitor utility, *Vol 2: M-Z, A–17*

Feedback  
 See AUTOGEN, feedback

FEEDBACK mode, *Vol 1: A-L, 6–1, 6–9*

Field of data  
 definition, *Vol 2: M-Z, 7–31*  
 definition of each, *Vol 2: M-Z, 7–32*  
 removing, *Vol 2: M-Z, 7–57*

Fields  
 SHOW CLUSTER, *Vol 2: M-Z, 7–1*

File backward link records  
 in accounting files, *Vol 1: A-L, 2–36*

File forward link records  
 in accounting files, *Vol 1: A-L, 2–36*

File primitive statistics  
 in Monitor utility, *Vol 2: M-Z, 1–32*

Files  
 AGEN\$FEEDBACK.DAT, *Vol 1: A-L, 6–6*  
 AGEN\$FEEDBACK.EXE, *Vol 1: A-L, 6–6*  
 AGEN\$PARAMS.REPORT, *Vol 1: A-L, 6–7*  
 ALPHAVMSSYS.OLD, *Vol 1: A-L, 6–8*  
 ALPHAVMSSYS.PAR, *Vol 1: A-L, 6–8*  
 AUTOGEN.PAR, *Vol 1: A-L, 6–6, 6–8; Vol 2: M-Z, 8–18, 8–20*  
 containing AUTOGEN feedback, *Vol 1: A-L, 6–6*  
 containing list of known images, *Vol 1: A-L, 6–7*  
 controlling access to, *Vol 1: A-L, 1–10, 1–12*  
 creating  
   dependency on directory ownership, *Vol 1: A-L, 1–8*  
   in a directory with a Default Protection ACE, *Vol 1: A-L, 1–10*  
 default parameter, *Vol 1: A-L, 6–8*  
 format required by ACL editor, *Vol 1: A-L, 1–2*  
 for paging, *Vol 1: A-L, 6–8*  
 for swapping, *Vol 1: A-L, 6–8*  
 for system crash dumps, *Vol 1: A-L, 6–8*  
 IA64VMSSYS.OLD, *Vol 1: A-L, 6–8*  
 IA64VMSSYS.PAR, *Vol 1: A-L, 6–8*  
 output cluster report, *Vol 2: M-Z, 7–17, 7–72*  
 parameter, *Vol 1: A-L, 6–6, 6–8; Vol 2: M-Z, 8–20*  
 PARAMS.DAT, *Vol 1: A-L, 6–7*  
 restoring  
   to original directories, *Vol 1: A-L, 7–7*  
 SETPARAMS.DAT, *Vol 1: A-L, 6–7, 6–8*  
 SHOW\_CLUSTER.LIS, *Vol 2: M-Z, 7–17, 7–72*  
 startup, *Vol 2: M-Z, 9–135*  
   disabling, *Vol 2: M-Z, 9–137*  
   displaying, *Vol 2: M-Z, 9–146*  
 startup command procedure, *Vol 2: M-Z, 8–10, 8–16, 8–20*  
 SYSGEN session output, *Vol 2: M-Z, 8–2, 8–9*  
 SYSGTTSTR.MSG, *Vol 2: M-Z, 8–17*  
 SYSMAN.LIS, *Vol 2: M-Z, 9–14, 9–32, 9–33, 9–50, 9–52, 9–53, 9–99, 9–146*  
 system parameter, *Vol 2: M-Z, 8–18, 8–20*  
 UIC-based protection  
   propagating in a directory tree, *Vol 1: A-L, 1–10*  
 used by AUTOGEN command procedure, *Vol 1: A-L, 6–9*  
 VAXVMSSYS.OLD, *Vol 1: A-L, 6–8*



## Files (cont'd)

- VAXVMSSYS.PAR, *Vol 1: A-L, 6–8; Vol 2: M-Z, 8–20*
- VMSIMAGES.DAT, *Vol 1: A-L, 6–7*
- writing alarm messages to audit logs, *Vol 1: A-L, 1–6*
- File system cache (ACP) system parameters
  - in Monitor utility, *Vol 2: M-Z, 1–37*
- File system cache statistics
  - monitoring, *Vol 2: M-Z, 1–34*
- /FILES\_SELECTED qualifier
  - in Backup utility, *Vol 1: A-L, 7–45*
- File types
  - specifying for ACL editor, *Vol 1: A-L, 1–2*
- FILE\_SYSTEM\_CACHE class record
  - in Monitor utility, *Vol 2: M-Z, A–19*
- FIND command
  - in PCSI, *Vol 2: M-Z, 4–33*
- Flags
  - login, *Vol 1: A-L, 5–9, 5–26, 5–40, 5–63*
- FLASH FIRMWARE command
  - in MSA utility, *Vol 2: M-Z, 2–9*
- /FLUSH\_INTERVAL qualifier
  - in Monitor utility, *Vol 2: M-Z, 1–13*
- Format for SHOW CLUSTER
  - specifying processor types, *Vol 2: M-Z, 7–36*
- Formats
  - of software kits
    - changing, *Vol 2: M-Z, 4–10*
- FREEGOAL system parameter, *Vol 2: M-Z, D–18*
- FREELIM system parameter, *Vol 2: M-Z, D–18*
- /FULL qualifier
  - in Backup utility, *Vol 1: A-L, 7–46*
- Function keys, *Vol 1: A-L, 14–18*

## G

- GALAXY system parameter, *Vol 2: M-Z, D–19*
- GBLPAGES system parameter, *Vol 2: M-Z, D–19*
- GBLPAGFIL system parameter, *Vol 2: M-Z, D–19*
- GBLSECTIONS system parameter, *Vol 2: M-Z, D–20*
- GB\_CACHEALLMAX system parameter, *Vol 2: M-Z, D–20*
- GB\_DEFPERCENT system parameter, *Vol 2: M-Z, D–20*
- GENFILES phase of AUTOGEN, *Vol 1: A-L, 6–8*
- GENPARAMS phase of AUTOGEN, *Vol 1: A-L, 6–7*
- GETDATA phase of AUTOGEN, *Vol 1: A-L, 6–7*
- GH\_EXEC\_CODE system parameter, *Vol 2: M-Z, D–20*
- GH\_EXEC\_DATA system parameter, *Vol 2: M-Z, D–21*
- GH\_RES\_CODE system parameter, *Vol 2: M-Z, D–21*

- GH\_RES\_CODE\_S2 system parameter, *Vol 2: M-Z, D–21*
- GH\_RES\_DATA system parameter, *Vol 2: M-Z, D–21*
- GH\_RSRVPGCNT system parameter, *Vol 2: M-Z, D–21*
- GLX\_INST\_TMO system parameter, *Vol 2: M-Z, D–21*
- GLX\_SHM\_REG system parameter, *Vol 2: M-Z, D–21*
- GRANT/IDENTIFIER command
  - in Authorize utility, *Vol 1: A-L, 5–50*
- Group number
  - cluster
    - displaying, *Vol 2: M-Z, 9–32*
    - local area cluster, *Vol 2: M-Z, 9–28*
- Groups
  - access to service nodes, *Vol 1: A-L, 14–39, 14–58*
  - access to services in LAT environment, *Vol 1: A-L, 14–34*
- /GROUP\_SIZE qualifier
  - in Backup utility, *Vol 1: A-L, 7–48*
- GROWLIM system parameter, *Vol 2: M-Z, D–21*

## H

- HANGUP characteristic
  - application LAT devices, *Vol 1: A-L, 14–9*
- /HEADER\_ONLY qualifier
  - in Backup utility, *Vol 1: A-L, 7–49*
- Help
  - online for Analyze Audit, *Vol 1: A-L, 4–32*
- HELP command
  - in Audit Analysis utility, *Vol 1: A-L, 4–32*
  - in Authorize utility, *Vol 1: A-L, 5–52*
  - in InfoServer utility, *Vol 1: A-L, 11–11*
  - in Install utility, *Vol 1: A-L, 12–13*
  - in LANCP utility, *Vol 1: A-L, 13–16*
  - in LATCP, *Vol 1: A-L, 14–26*
  - in LMCP, *Vol 1: A-L, 15–14*
  - in Monitor utility, *Vol 2: M-Z, 1–9*
  - in MSA utility, *Vol 2: M-Z, 2–10*
  - in Point-to-Point Protocol utility, *Vol 2: M-Z, 3–8*
  - in Show Cluster utility, *Vol 2: M-Z, 7–43*
  - in SYSMAN, *Vol 2: M-Z, 9–68*
  - in UCM, *Vol 2: M-Z, 10–18*
- HELP phase of AUTOGEN, *Vol 1: A-L, 6–9*
- History of installed software, *Vol 2: M-Z, 4–66*
- Holder Hidden attribute, *Vol 1: A-L, 5–19, 5–50, 5–72*
- Home blocks, *Vol 1: A-L, 3–4*
- /HOMEBLOCKS qualifier
  - in Analyze/Disk\_Structure utility, *Vol 1: A-L, 3–9*

HP 8 Internal Port SAS Host Bus Adapter  
See SAS Controller

## I

- I/O class record
  - in Monitor utility, *Vol 2: M-Z*, A-20
- I/O databases
  - displaying on Alpha and Integrity servers, *Vol 2: M-Z*, 9-89
- I/O statistics
  - in Monitor utility, *Vol 2: M-Z*, 1-38
- ICBM (IOGEN Configuration Building Module),  
*Vol 2: M-Z*, 9-85, 9-86, 9-92
- Identifier ACEs, *Vol 1: A-L*, 1-12
  - types of identifiers, *Vol 1: A-L*, 1-12
- Identifiers
  - default, *Vol 1: A-L*, 5-6
  - environmental, *Vol 1: A-L*, 1-12
  - general, *Vol 1: A-L*, 1-12, 1-14
  - granting, *Vol 1: A-L*, 1-12, 5-50
  - granting to a process, *Vol 1: A-L*, 1-14
  - renaming, *Vol 1: A-L*, 5-83
  - resource
    - and directory ownership, *Vol 1: A-L*, 1-8
    - revoking, *Vol 1: A-L*, 5-84
    - specifying characteristics of, *Vol 1: A-L*, 1-15
    - specifying multiple pairs of, *Vol 1: A-L*, 1-15
    - types, *Vol 1: A-L*, 1-12
- IEEE\_ADDRESSH system parameter, *Vol 2: M-Z*,  
D-22
- IEEE\_ADDRESS system parameter, *Vol 2: M-Z*,  
D-22
- /IGNORE qualifier
  - in Backup utility, *Vol 1: A-L*, 7-51
- IJOBLIM system parameter, *Vol 2: M-Z*, D-22
- Image
  - See System loadable image
  - accounting, *Vol 1: A-L*, 12-6, 12-21
  - applying an ACE to, *Vol 1: A-L*, 1-14
  - authorized privileges, *Vol 1: A-L*, 12-7, 12-22
  - header-resident, *Vol 1: A-L*, 12-7, 12-23
  - privileged, *Vol 1: A-L*, 12-7, 12-23
  - protecting installed, *Vol 1: A-L*, 12-8, 12-23
- Image backup
  - definition, *Vol 1: A-L*, 7-2
- Image mode, *Vol 1: A-L*, 7-54
- /IMAGE qualifier
  - in Backup utility, *Vol 1: A-L*, 7-54
- IMGIOCNT system parameter, *Vol 2: M-Z*, D-22
- IMGREG\_PAGES system parameter, *Vol 2: M-Z*,  
D-22
- Incoming LAT connections, *Vol 1: A-L*, 14-33
- Incremental backup
  - definition, *Vol 1: A-L*, 7-2
- Incremental mode
  - restoring files, *Vol 1: A-L*, 7-56
- /INCREMENTAL qualifier
  - in Backup utility, *Vol 1: A-L*, 7-56
- InfoServer utility
  - commands
    - CREATE SERVICE, *Vol 1: A-L*, 11-3
    - DELETE SERVICE, *Vol 1: A-L*, 11-7
    - EXIT, *Vol 1: A-L*, 11-10
    - HELP, *Vol 1: A-L*, 11-11
    - SAVE, *Vol 1: A-L*, 11-12
    - SET SERVICE, *Vol 1: A-L*, 11-15
    - SHOW SERVER, *Vol 1: A-L*, 11-18
    - SHOW SERVICES, *Vol 1: A-L*, 11-19
    - SHOW SESSIONS, *Vol 1: A-L*, 11-21
    - SPAWN, *Vol 1: A-L*, 11-23
    - START SERVER, *Vol 1: A-L*, 11-24
  - invoking, *Vol 1: A-L*, 11-2
- Initialization
  - erasing home blocks, *Vol 1: A-L*, 3-9
- Initialization files
  - creating, *Vol 2: M-Z*, 7-62
  - default specification, *Vol 2: M-Z*, 9-2
  - establishing SHOW CLUSTER reports, *Vol 2: M-Z*, 7-11
  - use with SYSMAN, *Vol 2: M-Z*, 9-2
- Initialization procedures, *Vol 1: A-L*, D-1
- INITIALIZE command
  - in Monitor utility, *Vol 2: M-Z*, 1-10
  - in Show Cluster utility, *Vol 2: M-Z*, 7-44
- /INITIALIZE qualifier
  - in Backup utility, *Vol 1: A-L*, 7-58
- INITIAL mode, *Vol 1: A-L*, 6-9
- Input files
  - security audit log files, *Vol 1: A-L*, 4-2
- /INPUT qualifier
  - in Monitor utility, *Vol 2: M-Z*, 1-13
- Input stream
  - switching control to other processes, *Vol 2: M-Z*, 9-15
- /INPUT\_FILES qualifier
  - in Backup utility, *Vol 1: A-L*, 7-60
- INSTALL command
  - in PCSI, *Vol 2: M-Z*, 4-36
  - in SYSGEN, *Vol 2: M-Z*, 8-7
- Installing software
  - getting product information, *Vol 2: M-Z*, 4-66
  - PCSI, *Vol 2: M-Z*, 4-36
  - removing software, *Vol 2: M-Z*, 4-64
- Install utility (INSTALL)
  - commands, *Vol 1: A-L*, 12-5 to 12-24
    - ADD, *Vol 1: A-L*, 12-5
    - CREATE, *Vol 1: A-L*, 12-6
    - DELETE, *Vol 1: A-L*, 12-11
    - EXIT, *Vol 1: A-L*, 12-12
    - HELP, *Vol 1: A-L*, 12-13
    - LIST, *Vol 1: A-L*, 12-14
    - PURGE, *Vol 1: A-L*, 12-19

Install utility (INSTALL)  
 commands (cont'd)  
   REMOVE, *Vol 1: A-L*, 12–20  
   REPLACE, *Vol 1: A-L*, 12–21  
   TRANSLATE, *Vol 1: A-L*, 12–2  
 exiting, *Vol 1: A-L*, 12–1  
 invoking, *Vol 1: A-L*, 12–1  
 /TRANSLATE qualifier, *Vol 1: A-L*, 12–2

Interactive commands  
 See Command mode for Audit Analysis utility

/INTERCHANGE qualifier  
 in Backup utility, *Vol 1: A-L*, 7–61

/INTERVAL qualifier, *Vol 2: M-Z*, 7–16  
 in Monitor utility, *Vol 2: M-Z*, 1–14  
 relationship of qualifier and event, *Vol 2: M-Z*, 1–14

Invoking AUTOGEN, *Vol 1: A-L*, 6–10  
 Invoking SYSGEN, *Vol 2: M-Z*, 8–2  
 Invoking SYSMAN, *Vol 2: M-Z*, 9–3

IO AUTOCONFIGURE command  
 in SYSMAN, *Vol 2: M-Z*, 9–69

IO CONNECT command  
 in SYSMAN, *Vol 2: M-Z*, 9–71

IO CREATE\_WWID command  
 in SYSMAN, *Vol 2: M-Z*, 9–75

IO FIND\_WWID command  
 in SYSMAN, *Vol 2: M-Z*, 9–76

IOGEN Configuration Building Module  
 See ICBM

IO LIST\_WWID command  
 in SYSMAN, *Vol 2: M-Z*, 9–79

IO LOAD command  
 in SYSMAN, *Vol 2: M-Z*, 9–80

IO REBUILD command  
 in SYSMAN, *Vol 2: M-Z*, 9–81

IO REPLACE\_WWID command  
 in SYSMAN, *Vol 2: M-Z*, 9–82

IO SCSI\_PATH\_VERIFY command  
 in SYSMAN, *Vol 2: M-Z*, 9–84

IO SET EXCLUDE command  
 in SYSMAN, *Vol 2: M-Z*, 9–85

IO SET PREFIX command  
 in SYSMAN, *Vol 2: M-Z*, 9–86

IO SHOW BUS command  
 in SYSMAN, *Vol 2: M-Z*, 9–87

IO SHOW DEVICE command  
 in SYSMAN, *Vol 2: M-Z*, 9–89

IO SHOW EXCLUDE command  
 in SYSMAN, *Vol 2: M-Z*, 9–91

IO SHOW PREFIX command  
 in SYSMAN, *Vol 2: M-Z*, 9–92

IOTA system parameter, *Vol 2: M-Z*, D–23

/IO\_LOAD qualifier  
 in Backup utility, *Vol 1: A-L*, 7–62

IO\_PRCPU\_BITMAP system parameter, *Vol 2: M-Z*, D–22  
 IRPCOUNT system parameter, *Vol 2: M-Z*, D–23  
 IRPCOUNTV system parameter, *Vol 2: M-Z*, D–23

## J

---

JBOBLIM system parameter, *Vol 2: M-Z*, D–23  
 JOBCTLD system parameter, *Vol 2: M-Z*, D–23  
 /JOURNAL qualifier  
 in Backup utility, *Vol 1: A-L*, 7–63

## K

---

Keypad definitions, *Vol 2: M-Z*, 7–11, 7–69  
 SHOW CLUSTER, *Vol 2: M-Z*, C–1

Keypad editing  
 editing commands, *Vol 1: A-L*, A–1  
 for ACL editor, *Vol 1: A-L*, A–1  
 LK201-specific editing commands, *Vol 1: A-L*, A–5

Keys  
 defining, *Vol 2: M-Z*, 9–34  
 defining in LATCP, *Vol 1: A-L*, 14–18  
 defining in SYSMAN, *Vol 2: M-Z*, 9–2  
 displaying definition, *Vol 2: M-Z*, 9–124

Known file entries, *Vol 1: A-L*, 12–1

Known file lists, *Vol 1: A-L*, 12–1

Known images, *Vol 1: A-L*, 12–1  
 adding, *Vol 1: A-L*, 12–5  
 attributes of, *Vol 1: A-L*, 12–16  
 creating, *Vol 1: A-L*, 12–6  
 deleting, *Vol 1: A-L*, 12–11  
 evaluating merits of installing, *Vol 1: A-L*, 12–14  
 removing, *Vol 1: A-L*, 12–20  
 replacing, *Vol 1: A-L*, 12–21  
 substituting, *Vol 1: A-L*, 12–2  
 updating, *Vol 1: A-L*, 12–2, 12–21

KSTACKPAGES system parameter, *Vol 2: M-Z*, D–23

## L

---

/LABEL qualifier  
 in Backup utility, *Vol 1: A-L*, 7–66

LANACP LAN Server process, *Vol 1: A-L*, 13–1  
 SET ACP command, *Vol 1: A-L*, 13–23

LAN addresses, *Vol 1: A-L*, 14–6  
 displaying, *Vol 1: A-L*, 14–58

LAN controllers  
 address, *Vol 1: A-L*, 14–58  
 device name, *Vol 1: A-L*, 14–7  
 physical address, *Vol 1: A-L*, 14–6

LAN Control Program (LANCP) utility  
 clearing counters, *Vol 1: A-L*, 13–7  
 commands, *Vol 1: A-L*, 13–4 to 14–1



LAN Control Program (LANCP) utility  
commands (cont'd)

CLEAR DEVICE, *Vol 1: A-L*, 13-6  
CLEAR DLL, *Vol 1: A-L*, 13-7  
CLEAR NODE, *Vol 1: A-L*, 13-8  
CONNECT NODE, *Vol 1: A-L*, 13-9  
CONVERT DEVICE\_DATABASE, *Vol 1: A-L*, 13-11  
CONVERT NODE\_DATABASE, *Vol 1: A-L*, 13-12  
DEFINE DEVICE, *Vol 1: A-L*, 13-13  
DEFINE NODE, *Vol 1: A-L*, 13-14  
@ (Execute Procedure), *Vol 1: A-L*, 13-4  
EXIT, *Vol 1: A-L*, 13-15  
HELP, *Vol 1: A-L*, 13-16  
LIST DEVICE, *Vol 1: A-L*, 13-17  
LIST NODE, *Vol 1: A-L*, 13-19  
PURGE DEVICE, *Vol 1: A-L*, 13-21  
PURGE NODE, *Vol 1: A-L*, 13-22  
SET ACP, *Vol 1: A-L*, 13-23  
SET DEVICE, *Vol 1: A-L*, 13-24  
SET NODE, *Vol 1: A-L*, 13-35  
SHOW ACP, *Vol 1: A-L*, 13-39  
SHOW CONFIGURATION, *Vol 1: A-L*, 13-40  
SHOW DEVICE, *Vol 1: A-L*, 13-42  
SHOW DLL, *Vol 1: A-L*, 13-46  
SHOW LOG, *Vol 1: A-L*, 13-47  
SHOW NODE, *Vol 1: A-L*, 13-49  
SPAWN, *Vol 1: A-L*, 13-51  
TRIGGER NODE, *Vol 1: A-L*, 13-52  
UPDATE DEVICE, *Vol 1: A-L*, 13-53  
deleting device information, *Vol 1: A-L*, 13-6, 13-21  
deleting node information, *Vol 1: A-L*, 13-8, 13-22  
displaying node information, *Vol 1: A-L*, 13-19, 13-49  
displaying OPCOM messages, *Vol 1: A-L*, 13-23  
displaying status and counters, *Vol 1: A-L*, 13-19, 13-46, 13-49  
exiting, *Vol 1: A-L*, 13-2  
invoking, *Vol 1: A-L*, 13-2  
MOP console carrier, *Vol 1: A-L*, 13-9  
MOP trigger boot, *Vol 1: A-L*, 13-52  
setting device information, *Vol 1: A-L*, 13-13  
LANCP (Local Area Network Control Program)  
See LAN Control Program (LANCP) utility  
LANs (local area networks)  
clearing counters, *Vol 1: A-L*, 13-7  
deleting device information, *Vol 1: A-L*, 13-6, 13-21  
deleting node information, *Vol 1: A-L*, 13-8, 13-22  
displaying LAN device parameters, *Vol 1: A-L*, 13-17, 13-42

LANs (local area networks) (cont'd)

displaying node information, *Vol 1: A-L*, 13-19, 13-49  
displaying OPCOM messages, *Vol 1: A-L*, 13-23  
displaying status and counters, *Vol 1: A-L*, 13-19, 13-46, 13-49  
LANCP SPAWN command, *Vol 1: A-L*, 13-51  
MOP console carrier, *Vol 1: A-L*, 13-9  
MOP trigger boot, *Vol 1: A-L*, 13-52  
setting device information, *Vol 1: A-L*, 13-13  
LAN\_FLAGS system parameter, *Vol 2: M-Z*, D-23  
Large buffers, *Vol 1: A-L*, 14-35  
LAT\$STARTUP.COM command procedure, *Vol 1: A-L*, 14-40  
LAT Control Program (LATCP) utility  
announcements, *Vol 1: A-L*, 14-32  
exiting, *Vol 1: A-L*, 14-25  
help, *Vol 1: A-L*, 14-26  
invoking, *Vol 1: A-L*, 14-2  
setting SCSSYSTEMID system parameter, *Vol 1: A-L*, 14-6  
LATCP  
See LAT Control Program utility  
LAT protocol  
Break-in attempts, *Vol 2: M-Z*, D-25  
LAT software  
changing DECserver characteristics, *Vol 1: A-L*, 14-9, 14-42  
characteristics  
added or changed, *Vol 1: A-L*, 14-1  
storing, *Vol 1: A-L*, 14-1  
connections, *Vol 1: A-L*, 14-38, 14-65  
incoming, *Vol 1: A-L*, 14-33  
specifying type of, *Vol 1: A-L*, 14-33  
devices  
changing HANGUP characteristic, *Vol 1: A-L*, 14-9  
device unit number, *Vol 1: A-L*, 14-39  
outgoing connections, *Vol 1: A-L*, 14-33  
service  
creating, *Vol 1: A-L*, 14-14  
database, *Vol 1: A-L*, 14-36, 14-39  
deleting, *Vol 1: A-L*, 14-24  
displaying characteristics of, *Vol 1: A-L*, 14-66  
displaying counters, *Vol 1: A-L*, 14-65  
displaying information, *Vol 1: A-L*, 14-65  
identifier, *Vol 1: A-L*, 14-14, 14-35, 14-46  
limiting size of node database, *Vol 1: A-L*, 14-36, 14-39  
modifying characteristics of, *Vol 1: A-L*, 14-46  
naming, *Vol 1: A-L*, 14-14, 14-30  
rating, *Vol 1: A-L*, 14-15, 14-47, 14-58, 14-66  
session limit, *Vol 1: A-L*, 14-34, 14-37

## LAT software (cont'd)

- starting with SET NODE/STATE=ON, *Vol 1: A-L*, 14–38
- stopping with SET NODE/STATE=OFF, *Vol 1: A-L*, 14–38

LCKMGR\_CPUID system parameter, *Vol 2: M-Z*, D–24

## LGI system parameters

- LGI\_BRK\_DISUSER, *Vol 2: M-Z*, D–25
- LGI\_BRK\_LIM, *Vol 2: M-Z*, D–25
- LGI\_BRK\_TERM, *Vol 2: M-Z*, D–25
- LGI\_BRK\_TMO, *Vol 2: M-Z*, D–25
- LGI\_CALLOUTS, *Vol 2: M-Z*, D–25
- LGI\_HID\_TIM, *Vol 2: M-Z*, D–26
- LGI\_PWD\_TMO, *Vol 2: M-Z*, D–26
- LGI\_RETRY\_LIM, *Vol 2: M-Z*, D–26
- LGI\_RETRY\_TMO, *Vol 2: M-Z*, D–26

See also System parameters

### Login security

## LICENSE LOAD command

- in SYSMAN, *Vol 2: M-Z*, 9–93

## Licenses

- deactivating, *Vol 2: M-Z*, 9–94

## LICENSE UNLOAD command

- in SYSMAN, *Vol 2: M-Z*, 9–94

Limited port, *Vol 1: A-L*, 14–10, 14–43

## /LIMIT qualifier

- in Backup utility, *Vol 1: A-L*, 7–68

## Links

- creating with LATCP, *Vol 1: A-L*, 14–6
- deleting with LATCP, *Vol 1: A-L*, 14–21
- displaying characteristics using LATCP, *Vol 1: A-L*, 14–52
- displaying counters using LATCP, *Vol 1: A-L*, 14–49
- displaying information using LATCP, *Vol 1: A-L*, 14–49
- modifying characteristics using LATCP, *Vol 1: A-L*, 14–30
- name options in LATCP, *Vol 1: A-L*, 14–6
- state of in LAT environment, *Vol 1: A-L*, 14–7

## LIST/IDENTIFIER command

- in Authorize utility, *Vol 1: A-L*, 5–56

## LIST/PROXY command

- in Authorize utility, *Vol 1: A-L*, 5–58

## LIST/RIGHTS command

- in Authorize utility, *Vol 1: A-L*, 5–59

## LIST command

- in Audit Analysis utility, *Vol 1: A-L*, 4–33
- in Authorize utility, *Vol 1: A-L*, 5–54
- in Install utility, *Vol 1: A-L*, 12–14
- in PCSI, *Vol 2: M-Z*, 4–42

## LIST DEVICE command

- in LANCP utility, *Vol 1: A-L*, 13–17

## Listing

- network proxy database, *Vol 1: A-L*, 5–58
- rights database, *Vol 1: A-L*, 5–56, 5–59

## Listing (cont'd)

- save-set information, *Vol 1: A-L*, 7–18, 7–46, 7–69

system user authorization file (SYSUAF), *Vol 1: A-L*, 5–54

## LIST NODE command

- in LANCP utility, *Vol 1: A-L*, 13–19

## /LIST qualifier, *Vol 1: A-L*, 3–4

- in Analyze/Disk\_Structure utility, *Vol 1: A-L*, 3–10

in Backup utility, *Vol 1: A-L*, 7–69

LK201-specific editing commands, *Vol 1: A-L*, A–5

## LMCP

See Log Manager Control Program (LMCP) utility

LNMPHASHTBL system parameter, *Vol 2: M-Z*, D–26

LNMSHASHTBL system parameter, *Vol 2: M-Z*, D–26

Load balancing, *Vol 1: A-L*, 14–15, 14–47

and CPU power, *Vol 1: A-L*, 14–33

## Loading device drivers

- on Alpha and Integrity servers, *Vol 2: M-Z*, 9–69, 9–71, 9–80

LOAD\_PWD\_POLICY system parameter, *Vol 2: M-Z*, D–26

LOAD\_SYS\_IMAGES system parameter, *Vol 2: M-Z*, D–27

## Local area cluster environments

- setting system date and time, *Vol 2: M-Z*, 9–30

## LOCAL\_PORTS class

- adding, *Vol 2: M-Z*, 7–33
- fields belonging to, *Vol 2: M-Z*, 7–6
- removing, *Vol 2: M-Z*, 7–58

## LOCATE command

- in MSA utility, *Vol 2: M-Z*, 2–11

## LOCK class record

- in Monitor utility, *Vol 2: M-Z*, A–22

LOCKDIRWT system parameter, *Vol 2: M-Z*, D–27

LOCKIDTBL system parameter, *Vol 2: M-Z*, D–27

LOCKIDTBL\_MAX system parameter, *Vol 2: M-Z*, D–27

LOCKRETRY system parameter, *Vol 2: M-Z*, D–27

LOCKRMWT system parameter, *Vol 2: M-Z*, D–27

## /LOCK\_VOLUME qualifier

- in Analyze/Disk\_Structure utility, *Vol 1: A-L*, 3–11

## Login command procedures

- LOGIN.COM, *Vol 1: A-L*, 5–48

Log Manager Control Program (LMCP) utility, *Vol 1: A-L*, 15–1

CLOSE LOG command, *Vol 1: A-L*, 15–3

CONVERT LOG command, *Vol 1: A-L*, 15–4

CREATE LOG command, *Vol 1: A-L*, 15–6

Log Manager Control Program (LMCP) utility  
(cont'd)  
 DUMP command, *Vol 1: A-L*, 15–8  
 EXIT command, *Vol 1: A-L*, 15–13  
 HELP command, *Vol 1: A-L*, 15–14  
 REPAIR command, *Vol 1: A-L*, 15–15  
 SHOW LOG command, *Vol 1: A-L*, 15–18  
 /LOG qualifier  
   in Backup utility, *Vol 1: A-L*, 7–71  
 LONGWAIT system parameter, *Vol 2: M-Z*, D–28  
 Lost files  
   recovering, *Vol 1: A-L*, 3–3  
 LPBEGIN phase of system startup, *Vol 2: M-Z*,  
 9–142  
 LPBETA phase of system startup, *Vol 2: M-Z*,  
 9–142  
 LPMAIN phase of system startup, *Vol 2: M-Z*,  
 9–142  
 LTA device, *Vol 1: A-L*, 14–33  
 LTDRIVER (LAT port driver)  
   turning on and off, *Vol 1: A-L*, 14–1

## M

Magnetic tape devices  
   serving within a cluster, *Vol 2: M-Z*, D–67  
 Management environment  
   defining, *Vol 2: M-Z*, 9–119  
 MAXBOB\* system parameters, *Vol 2: M-Z*, D–28  
 MAXBOBMEM system parameter, *Vol 2: M-Z*,  
 D–28  
 MAXBUF system parameter, *Vol 2: M-Z*, D–28  
 MAXCLASSPRI system parameter, *Vol 2: M-Z*,  
 D–28  
 MAXPROCESSCNT system parameter, *Vol 2:*  
*M-Z*, D–29  
 MAXQUEUEPRI system parameter, *Vol 2: M-Z*,  
 D–29  
 MAXSYSGROUP system parameter, *Vol 2: M-Z*,  
 D–29  
 MC\_SERVICES\_P0 system parameter, *Vol 2:*  
*M-Z*, D–29  
 MC\_SERVICES\_P1 system parameter, *Vol 2:*  
*M-Z*, D–29  
 MC\_SERVICES\_P2 system parameter, *Vol 2:*  
*M-Z*, D–29  
 MC\_SERVICES\_P3 system parameter, *Vol 2:*  
*M-Z*, D–30  
 MC\_SERVICES\_P4 system parameter, *Vol 2:*  
*M-Z*, D–30  
 MC\_SERVICES\_P5 system parameter, *Vol 2:*  
*M-Z*, D–30  
 MC\_SERVICES\_P6 system parameter, *Vol 2:*  
*M-Z*, D–30  
 MC\_SERVICES\_P7 system parameter, *Vol 2:*  
*M-Z*, D–30

MC\_SERVICES\_P8 system parameter, *Vol 2:*  
*M-Z*, D–31  
 MC\_SERVICES\_P9 system parameter, *Vol 2:*  
*M-Z*, D–31  
 /MEDIA\_FORMAT qualifier  
   in Backup utility, *Vol 1: A-L*, 7–72  
 MEMBERS class  
   adding, *Vol 2: M-Z*, 7–35  
   fields belonging to, *Vol 2: M-Z*, 7–7  
   removing, *Vol 2: M-Z*, 7–59  
 Memory reservations  
   displays on running system, *Vol 2: M-Z*, 9–117  
   frees on running system, *Vol 2: M-Z*, 9–110  
 MINCLASSPRI system parameter, *Vol 2: M-Z*,  
 D–31  
 MINWSCNT system parameter, *Vol 2: M-Z*, D–31  
 MMG\_CTLFLAGS system parameter, *Vol 2: M-Z*,  
 D–31  
 MODES class record  
   in Monitor utility, *Vol 2: M-Z*, A–23  
 Modes of execution, *Vol 1: A-L*, 6–9  
   for SYSMAN startup files, *Vol 2: M-Z*, 9–135  
 Modes of operation, *Vol 1: A-L*, 3–2  
   image, *Vol 1: A-L*, 7–54  
   physical, *Vol 1: A-L*, 7–78  
 /MODIFIED qualifier  
   in Backup utility, *Vol 1: A-L*, 7–73  
 MODIFY/IDENTIFIER command  
   in Authorize utility, *Vol 1: A-L*, 5–72  
 MODIFY/PROXY command  
   in Authorize utility, *Vol 1: A-L*, 5–74  
 MODIFY/SYSTEM\_PASSWORD command  
   in Authorize utility, *Vol 1: A-L*, 5–76  
 MODIFY command  
   in Authorize utility, *Vol 1: A-L*, 5–60  
 MODIFY DEVICE command  
   in UCM, *Vol 2: M-Z*, 10–19  
 Modifying page, swap, and dump file sizes, *Vol 1:*  
*A-L*, 6–1  
 Modifying system parameters  
   recommended method, *Vol 1: A-L*, 6–1  
 MONITOR ALL\_CLASSES command  
   in Monitor utility, *Vol 2: M-Z*, 1–17  
 MONITOR CLUSTER command  
   in Monitor utility, *Vol 2: M-Z*, 1–19  
 MONITOR command  
   in Monitor utility, *Vol 2: M-Z*, 1–11  
 MONITOR DECNET command  
   in Monitor utility, *Vol 2: M-Z*, 1–24  
 MONITOR DISK command  
   in Monitor utility, *Vol 2: M-Z*, 1–26  
 MONITOR DLOCK command  
   in Monitor utility, *Vol 2: M-Z*, 1–29  
 MONITOR FCP command  
   in Monitor utility, *Vol 2: M-Z*, 1–32  
 MONITOR FILE\_SYSTEM\_CACHE command  
   in Monitor utility, *Vol 2: M-Z*, 1–34

MONITOR IO command  
 in Monitor utility, *Vol 2: M-Z*, 1–38

MONITOR LOCK command  
 in Monitor utility, *Vol 2: M-Z*, 1–40

MONITOR MODES command  
 in Monitor utility, *Vol 2: M-Z*, 1–42

MONITOR MSCP\_SERVER command  
 in Monitor utility, *Vol 2: M-Z*, 1–46

MONITOR PAGE command  
 in Monitor utility, *Vol 2: M-Z*, 1–48

MONITOR PROCESSES command  
 in Monitor utility, *Vol 2: M-Z*, 1–50

MONITOR RLOCK command  
 in Monitor utility, *Vol 2: M-Z*, 1–56

MONITOR RMS command  
 in Monitor utility, *Vol 2: M-Z*, 1–58

MONITOR SCS command  
 in Monitor utility, *Vol 2: M-Z*, 1–62

MONITOR STATES command  
 in Monitor utility, *Vol 2: M-Z*, 1–66

MONITOR SYSTEM command  
 in Monitor utility, *Vol 2: M-Z*, 1–70

MONITOR TIMER command  
 in Monitor utility, *Vol 2: M-Z*, 1–74

MONITOR TRANSACTION command  
 in Monitor utility, *Vol 2: M-Z*, 1–76

Monitor utility (MONITOR)  
 classname qualifiers  
   /ALL, *Vol 2: M-Z*, 1–56  
   /CPU, *Vol 2: M-Z*, 1–42  
   /ITEM, *Vol 2: M-Z*, 1–26, 1–62  
   /TOPBIO, *Vol 2: M-Z*, 1–50  
   /TOPCPU, *Vol 2: M-Z*, 1–50  
   /TOPDIO, *Vol 2: M-Z*, 1–50  
   /TOPEXECUTIVE, *Vol 2: M-Z*, 1–50  
   /TOPKERNEL, *Vol 2: M-Z*, 1–51  
   /TOPSUPERVISOR, *Vol 2: M-Z*, 1–51  
   /TOPUSER, *Vol 2: M-Z*, 1–51

Cluster performance statistics, *Vol 2: M-Z*, 1–19

collection interval, *Vol 2: M-Z*, 1–14

command qualifiers, *Vol 2: M-Z*, 1–11 to 1–16

commands, *Vol 2: M-Z*, 1–4 to 1–82

  ALIGN, *Vol 2: M-Z*, 1–5

  CONVERT, *Vol 2: M-Z*, 1–6

  EXECUTE, *Vol 2: M-Z*, 1–7

  EXIT, *Vol 2: M-Z*, 1–8

  HELP, *Vol 2: M-Z*, 1–9

  INITIALIZE, *Vol 2: M-Z*, 1–10

  MONITOR, *Vol 2: M-Z*, 1–11

  MONITOR ALL\_CLASSES, *Vol 2: M-Z*, 1–17

  MONITOR CLUSTER, *Vol 2: M-Z*, 1–19

  MONITOR DECNET, *Vol 2: M-Z*, 1–24

  MONITOR DISK, *Vol 2: M-Z*, 1–26

  MONITOR DLOCK, *Vol 2: M-Z*, 1–29

  MONITOR FCP, *Vol 2: M-Z*, 1–32

Monitor utility (MONITOR)  
 commands (cont'd)

  MONITOR FILE\_SYSTEM\_CACHE, *Vol 2: M-Z*, 1–34

  MONITOR IO, *Vol 2: M-Z*, 1–38

  MONITOR LOCK, *Vol 2: M-Z*, 1–40

  MONITOR MODES, *Vol 2: M-Z*, 1–42

  MONITOR MSCP\_SERVER, *Vol 2: M-Z*, 1–46

  MONITOR PAGE, *Vol 2: M-Z*, 1–48

  MONITOR PROCESSES, *Vol 2: M-Z*, 1–50

  MONITOR RLOCK, *Vol 2: M-Z*, 1–56

  MONITOR RMS, *Vol 2: M-Z*, 1–58

  MONITOR SCS, *Vol 2: M-Z*, 1–62

  MONITOR STATES, *Vol 2: M-Z*, 1–66

  MONITOR SYSTEM, *Vol 2: M-Z*, 1–70

  MONITOR TIMER, *Vol 2: M-Z*, 1–74

  MONITOR TRANSACTION, *Vol 2: M-Z*, 1–76

  MONITOR VECTOR, *Vol 2: M-Z*, 1–79

  SET DEFAULT, *Vol 2: M-Z*, 1–81

  SHOW DEFAULT, *Vol 2: M-Z*, 1–82

  directing output, *Vol 2: M-Z*, 1–3

  exiting, *Vol 2: M-Z*, 1–3

  invoking, *Vol 2: M-Z*, 1–3

  recording file record formats, *Vol 2: M-Z*, A–1 to A–13

  relationship of qualifier and event, *Vol 2: M-Z*, 1–14

MONITOR\_SERVER process  
 created on remote cluster node, *Vol 2: M-Z*, 1–20

  log file, *Vol 2: M-Z*, 1–21

  network startup, *Vol 2: M-Z*, 1–21

  purpose, *Vol 2: M-Z*, 1–20

  startup time, *Vol 2: M-Z*, 1–21

MOP downline load services  
 clearing counters, *Vol 1: A-L*, 13–7

  console carrier, *Vol 1: A-L*, 13–9

  displaying status and counters, *Vol 1: A-L*, 13–19, 13–49

  trigger boot, *Vol 1: A-L*, 13–52

MOUNT command  
 avoiding use of /CLUSTER with SYSMAN DO command, *Vol 2: M-Z*, 9–52

Mount error message, *Vol 1: A-L*, 7–88

MOUNTMSG system parameter, *Vol 2: M-Z*, D–32

Mount verification  
 forced by VERIFY utility, *Vol 1: A-L*, 3–2

MOVE command  
 in Show Cluster utility, *Vol 2: M-Z*, 7–45

MOVE keypad function, *Vol 2: M-Z*, C–3

MPDEV\_AFB\_INTVL system parameter, *Vol 2: M-Z*, D–32

MPDEV\_D\* system parameters, *Vol 2: M-Z*, D–32



MPDEV\_ENABLE system parameter, *Vol 2: M-Z, D-32*

MPDEV\_LCRETRIES system parameter, *Vol 2: M-Z, D-32*

MPDEV\_POLLER system parameter, *Vol 2: M-Z, D-32*

MPDEV\_REMOTE system parameter, *Vol 2: M-Z, D-33*

MPW\_HILIMIT system parameter, *Vol 2: M-Z, D-33*

MPW\_IOLIMIT system parameter, *Vol 2: M-Z, D-33*

MPW\_LOLIMIT system parameter, *Vol 2: M-Z, D-33*

MPW\_LOWAITLIMIT system parameter, *Vol 2: M-Z, D-33*

MPW\_PRIO system parameter, *Vol 2: M-Z, D-33*

MPW\_THRESH system parameter, *Vol 2: M-Z, D-34*

MPW\_WAITLIMIT system parameter, *Vol 2: M-Z, D-34*

MPW\_WRTCLUSTER system parameter, *Vol 2: M-Z, D-34*

MSA  
 utility, *Vol 2: M-Z, 2-1*

MSA utility  
 ACCEPT UNIT command, *Vol 2: M-Z, 2-3*  
 ADD UNIT command, *Vol 2: M-Z, 2-4*  
 commands, *Vol 2: M-Z, 2-2*  
 DELETE UNIT command, *Vol 2: M-Z, 2-7*  
 EXIT command, *Vol 2: M-Z, 2-8*  
 FLASH FIRMWARE command, *Vol 2: M-Z, 2-9*  
 HELP command, *Vol 2: M-Z, 2-10*  
 LOCATE command, *Vol 2: M-Z, 2-11*  
 privileges required, *Vol 2: M-Z, 2-1*  
 READ FIRMWARE command, *Vol 2: M-Z, 2-13*  
 RESET OTHER\_CONTROLLER command, *Vol 2: M-Z, 2-15*  
 RESET THIS\_CONTROLLER command, *Vol 2: M-Z, 2-14*  
 restrictions, *Vol 2: M-Z, 2-1*  
 SCAN ALL command, *Vol 2: M-Z, 2-16*  
 SET CONTROLLER, *Vol 2: M-Z, 2-17*  
 SET GLOBALS, *Vol 2: M-Z, 2-18*  
 SET UNIT command, *Vol 2: M-Z, 2-20*  
 SHOW CONNECTIONS command, *Vol 2: M-Z, 2-25*  
 SHOW CONTROLLER command, *Vol 2: M-Z, 2-26*  
 SHOW DISKS command, *Vol 2: M-Z, 2-29*  
 SHOW GLOBALS command, *Vol 2: M-Z, 2-32*  
 SHOW OTHER\_CONTROLLER command, *Vol 2: M-Z, 2-34*  
 SHOW PROFILE command, *Vol 2: M-Z, 2-33*  
 SHOW THIS\_CONTROLLER command, *Vol 2: M-Z, 2-35*

MSA utility (cont'd)  
 SHOW UNIT command, *Vol 2: M-Z, 2-36*  
 SHOW UNITS command, *Vol 2: M-Z, 2-37*  
 SHOW VERSION command, *Vol 2: M-Z, 2-38, 2-39*  
 usage summary, *Vol 2: M-Z, 2-1*

MSA Utility, *Vol 2: M-Z, 2-1*

MSCP\_BUFFER system parameter, *Vol 2: M-Z, D-34*

MSCP\_CMD\_TMO system parameter, *Vol 2: M-Z, D-34*

MSCP\_CREDITS system parameter, *Vol 2: M-Z, D-35*

MSCP\_LOAD system parameter, *Vol 2: M-Z, D-35*

MSCP\_SERVER class record  
 in Monitor utility, *Vol 2: M-Z, A-25*

MSCP\_SERVE\_ALL system parameter, *Vol 2: M-Z, D-35*

Multi-architecture OpenVMS Cluster systems  
 installing images, *Vol 2: M-Z, 9-52*

Multicast address  
 cluster  
 displaying, *Vol 2: M-Z, 9-32*

Multicast messages, *Vol 1: A-L, 14-24, 14-49*  
 timer for, *Vol 1: A-L, 14-36*

MULTIPROCESSING system parameter, *Vol 2: M-Z, D-36*

MULTITHREAD system parameter, *Vol 2: M-Z, D-36*

MVSUPMSG\_INTVL system parameter, *Vol 2: M-Z, D-37*

MVSUPMSG\_NUM system parameter, *Vol 2: M-Z, D-37*

MVTIMEOUT system parameter, *Vol 2: M-Z, D-37*

## N

Name Hidden attribute, *Vol 1: A-L, 5-19, 5-50, 5-72*

NET\$PROXY.DAT files  
 description of, *Vol 1: A-L, 5-1*

NETPROXY.DAT files  
 creating, *Vol 1: A-L, 5-35*  
 description of, *Vol 1: A-L, 5-1*  
 displaying proxy access, *Vol 1: A-L, 5-92*  
 modifying, *Vol 1: A-L, 5-1*

Network proxy authorization files, *Vol 1: A-L, 5-1*  
 creating, *Vol 1: A-L, 5-35*  
 modifying, *Vol 1: A-L, 5-1*

Network statistics  
 in Monitor utility, *Vol 2: M-Z, 1-24*

NET\_CALLOUTS system parameter, *Vol 2: M-Z, D-37*

NEWPARAMS.DAT file, *Vol 1: A-L, 6-2*  
 contents, *Vol 1: A-L, 6-3*

/NEW\_VERSION qualifier  
     in Backup utility, *Vol 1: A-L*, 7–74  
 NEXT FILE command  
     in Audit Analysis utility, *Vol 1: A-L*, 4–34  
 NEXT RECORD command  
     in Audit Analysis utility, *Vol 1: A-L*, 4–35  
 NISCS\_CONV\_BOOT system parameter, *Vol 2: M-Z*, D–37  
 NISCS\_LOAD\_PEA0 system parameter, *Vol 2: M-Z*, D–37  
 NISCS\_MAX\_PKTSZ system parameter, *Vol 2: M-Z*, D–37  
 NISCS\_PORT\_SERV system parameter, *Vol 2: M-Z*, D–38  
 No Access attribute, *Vol 1: A-L*, 5–19, 5–50, 5–72  
 NOAUTOCONFIG system parameter, *Vol 2: M-Z*, D–39  
 NOCLUSTER system parameter, *Vol 2: M-Z*, D–39  
 Node names, *Vol 1: A-L*, 14–32  
 Node numbers  
     display on Alpha and Integrity servers, *Vol 2: M-Z*, 9–87  
 /NODE qualifier  
     in Monitor utility, *Vol 2: M-Z*, 1–15  
 Nodes  
     database, *Vol 1: A-L*, 14–36, 14–39  
     deleting node information, *Vol 1: A-L*, 13–8, 13–22  
     displaying characteristics of, *Vol 1: A-L*, 14–57  
     displaying counters, *Vol 1: A-L*, 14–54  
     displaying information using LATCP, *Vol 1: A-L*, 14–54  
     limit, *Vol 1: A-L*, 14–36  
     modifying characteristics of, *Vol 1: A-L*, 14–32  
     state, *Vol 1: A-L*, 14–38  
     target, *Vol 1: A-L*, 14–62  
 NOFEEDBACK mode, *Vol 1: A-L*, 6–9  
 NOPGFLSWP system parameter, *Vol 2: M-Z*, D–39  
 /[NO]CONFIRM qualifier  
     in Analyze/Disk\_Structure utility, *Vol 1: A-L*, 3–8  
 /[NO]LIST qualifier  
     in Analyze/Disk\_Structure utility, *Vol 1: A-L*, 3–10  
 /[NO]LOCK\_VOLUME qualifier  
     in Analyze/Disk\_Structure utility, *Vol 1: A-L*, 3–11  
 /[NO]READ\_CHECK qualifier  
     in Analyze/Disk\_Structure utility, *Vol 1: A-L*, 3–13  
 /[NO]REPAIR qualifier  
     in Analyze/Disk\_Structure utility, *Vol 1: A-L*, 3–15

NPAGECALC system parameter, *Vol 2: M-Z*, D–39  
 NPAGEDYN system parameter, *Vol 2: M-Z*, D–40  
 NPAGERAD system parameter, *Vol 2: M-Z*, D–40  
 NPAGEVIR system parameter, *Vol 2: M-Z*, D–41  
 NPAG\_AGGRESSIVE system parameter, *Vol 2: M-Z*, D–41  
 NPAG\_BAP\_MAX system parameter, *Vol 2: M-Z*, D–41  
 NPAG\_BAP\_MAX\_PA system parameter, *Vol 2: M-Z*, D–41  
 NPAG\_BAP\_MIN system parameter, *Vol 2: M-Z*, D–41  
 NPAG\_BAP\_MIN\_PA system parameter, *Vol 2: M-Z*, D–41  
 NPAG\_GENTLE system parameter, *Vol 2: M-Z*, D–42  
 NPAG\_INTERVAL system parameter, *Vol 2: M-Z*, D–42  
 NPAG\_RING\_SIZE system parameter, *Vol 2: M-Z*, D–42

## O

Object classes  
     security class object, *Vol 1: A-L*, 1–2  
 Objects  
     controlling access to, *Vol 1: A-L*, 1–12  
 Object types  
     See Object classes  
 OPCOM (Operator Communication Manager)  
     messages  
         generated by LANACP, *Vol 1: A-L*, 13–23  
 OpenVMS Backup utility  
     See Backup utility (BACKUP)  
 OpenVMS Cluster environments  
     command execution, *Vol 2: M-Z*, 9–52  
     DCL commands interacting with SYSMAN  
         cluster commands, *Vol 2: M-Z*, 9–3  
     displaying group number, *Vol 2: M-Z*, 9–32  
     displaying multicast address, *Vol 2: M-Z*, 9–32  
     displaying network information, *Vol 2: M-Z*, 9–32  
     displaying system date and time, *Vol 2: M-Z*, 9–33  
     dual-architecture  
         installing images, *Vol 2: M-Z*, 9–53  
     group number, *Vol 2: M-Z*, 9–28  
     modifying security data, *Vol 2: M-Z*, 9–28  
     multi-architecture  
         installing images, *Vol 2: M-Z*, 9–52  
     password, *Vol 2: M-Z*, 9–28  
     setting time, *Vol 2: M-Z*, 9–30  
     updating security data, *Vol 2: M-Z*, 9–28  
 OpenVMS RMS  
     See RMS

Operations  
 compare  
   for BACKUP, *Vol 1: A-L, 7-25*  
 list, *Vol 1: A-L, 7-18, 7-46, 7-69*  
 performed by BACKUP, *Vol 1: A-L, 7-1*  
 Operator assistance  
   with BACKUP, *Vol 1: A-L, 7-14*  
 /OUTPUT qualifier, *Vol 2: M-Z, 7-17*  
   in Monitor utility, *Vol 2: M-Z, 1-15*  
 /OVERLAY qualifier  
   in Backup utility, *Vol 1: A-L, 7-75, 7-76*  
 /OWNER\_UIC qualifier  
   as Backup utility input file qualifier, *Vol 1: A-L, 7-77*

## P

PACKAGE command  
   in PCSI, *Vol 2: M-Z, 4-46*  
 /PAGE=SAVE qualifier navigation keys, *Vol 1: A-L, 5-86*  
 PAGE class record  
   in Monitor utility, *Vol 2: M-Z, A-26*  
 PAGED\_LAL\_SIZE system parameter, *Vol 2: M-Z, D-42*  
 PAGEFILE.SYS file  
   See Page files  
 Page files  
   changing size, *Vol 1: A-L, 6-1*  
   displaying the size calculated by AUTOGEN, *Vol 1: A-L, 6-7*  
   generating a new file sized by AUTOGEN, *Vol 1: A-L, 6-8*  
 Page management statistics  
   in Monitor utility, *Vol 2: M-Z, 1-48*  
 PAGFILCNT system parameter, *Vol 2: M-Z, D-42*  
 PAGTBLPFC system parameter, *Vol 2: M-Z, D-42*  
 PAMAXPORT system parameter, *Vol 2: M-Z, D-42*  
 PAN command  
   in Show Cluster utility, *Vol 2: M-Z, 7-47*  
 PAN keypad function, *Vol 2: M-Z, C-3*  
 PANOPOLL system parameter, *Vol 2: M-Z, D-43*  
 PANUMPOLL system parameter, *Vol 2: M-Z, D-43*  
 PAPOLLINTERVAL system parameter, *Vol 2: M-Z, D-43*  
 PAPOOLINTERVAL system parameter, *Vol 2: M-Z, D-43*  
 Parameter files  
   ALPHAVMSSYS.OLD, *Vol 1: A-L, 6-8*  
   ALPHAVMSSYS.PAR, *Vol 1: A-L, 6-8*  
   AUTOGEN.PAR, *Vol 1: A-L, 6-8*  
   default, *Vol 1: A-L, 6-8*  
   IA64VMSSYS.OLD, *Vol 1: A-L, 6-8*  
   IA64VMSSYS.PAR, *Vol 1: A-L, 6-8*  
   VAXVMSSYS.OLD, *Vol 1: A-L, 6-8*  
   Parameter files (cont'd)  
   VAXVMSSYS.PAR, *Vol 1: A-L, 6-8*  
   writing, *Vol 2: M-Z, 8-20, 9-104*  
 Parameters  
   See also System parameters  
   changing, *Vol 2: M-Z, 9-97*  
   passing to command procedures, *Vol 1: A-L, 13-4*  
 PARAMETERS DISABLE CHECKS command  
   in SYSMAN, *Vol 2: M-Z, 9-95*  
 PARAMETERS ENABLE CHECKS command  
   in SYSMAN, *Vol 2: M-Z, 9-96*  
 PARAMETERS SET command  
   in SYSMAN, *Vol 2: M-Z, 9-97*  
 PARAMETERS SHOW command  
   in SYSMAN, *Vol 2: M-Z, 9-98*  
 PARAMETERS USE command  
   in SYSMAN, *Vol 2: M-Z, 9-103*  
 PARAMETERS WRITE command  
   in SYSMAN, *Vol 2: M-Z, 9-104*  
 PARAMS.DAT file, *Vol 1: A-L, 6-7, 6-8*  
 PASANITY system parameter, *Vol 2: M-Z, D-44*  
 Password, *Vol 2: M-Z, 9-119*  
   for OpenVMS Cluster, *Vol 2: M-Z, 9-28*  
 PASTDGBUF system parameter, *Vol 2: M-Z, D-44*  
 Paste buffers, *Vol 1: A-L, A-5*  
 PASTIMOUT system parameter, *Vol 2: M-Z, D-44*  
 PCFs (product configuration files)  
   CONFIGURE subcommand, *Vol 2: M-Z, 4-6*  
 PCSI, *Vol 2: M-Z, 4-1*  
   See also PRODUCT command  
   commands  
     ANALYZE PDB, *Vol 2: M-Z, 4-4*  
     CONFIGURE, *Vol 2: M-Z, 4-6*  
     COPY, *Vol 2: M-Z, 4-10*  
     DELETE RECOVERY\_DATA, *Vol 2: M-Z, 4-15*  
     EXTRACT FILE, *Vol 2: M-Z, 4-17*  
     EXTRACT PDF, *Vol 2: M-Z, 4-21*  
     EXTRACT PTF, *Vol 2: M-Z, 4-25*  
     EXTRACT RELEASE\_NOTES, *Vol 2: M-Z, 4-29*  
     FIND, *Vol 2: M-Z, 4-33*  
     INSTALL, *Vol 2: M-Z, 4-36*  
     LIST, *Vol 2: M-Z, 4-42*  
     PACKAGE, *Vol 2: M-Z, 4-46*  
     RECONFIGURE, *Vol 2: M-Z, 4-51*  
     REGISTER PRODUCT, *Vol 2: M-Z, 4-57*  
     REGISTER VOLUME, *Vol 2: M-Z, 4-62*  
     REMOVE, *Vol 2: M-Z, 4-64*  
     SHOW HISTORY, *Vol 2: M-Z, 4-66*  
     SHOW OBJECT, *Vol 2: M-Z, 4-69*  
     SHOW PRODUCT, *Vol 2: M-Z, 4-72*  
     SHOW RECOVERY\_DATA, *Vol 2: M-Z, 4-75*  
   invoking, *Vol 2: M-Z, 4-1*

- PCSI (cont'd)
  - parameters, *Vol 2: M-Z*, 4–1
- PDB (product database)
  - recording a volume label change, *Vol 2: M-Z*, 4–62
- PDFs (product description files)
  - of software products, *Vol 2: M-Z*, 4–21
- PEdriver
  - event-tracing facility, *Vol 2: M-Z*, 6–5
- Per-connection buffers
  - allocating, *Vol 2: M-Z*, D–9
- PE system parameters, *Vol 2: M-Z*, D–44
- PFCDEFAULT system parameter, *Vol 2: M-Z*, D–44
- PFN\_COLOR\_COUNT system parameter, *Vol 2: M-Z*, D–45
- PFRATH system parameter, *Vol 2: M-Z*, D–45
- PFRATL system parameter, *Vol 2: M-Z*, D–45
- Phases of AUTOGEN, *Vol 1: A-L*, 6–6
- Physical mode, *Vol 1: A-L*, 7–78
- /PHYSICAL qualifier
  - in Backup utility, *Vol 1: A-L*, 7–78
- PHYSICAL\_MEMORY system parameter, *Vol 2: M-Z*, D–45
- PIOPAGES system parameter, *Vol 2: M-Z*, D–45
- PIXSCAN system parameter, *Vol 2: M-Z*, D–46
- Point-to-Point Protocol utility (PPPD)
  - commands
    - CONNECT, *Vol 2: M-Z*, 3–3
    - DIAL\_OUT, *Vol 2: M-Z*, 3–4
    - DISCONNECT, *Vol 2: M-Z*, 3–6
    - EXIT, *Vol 2: M-Z*, 3–7
    - HELP, *Vol 2: M-Z*, 3–8
    - SET, *Vol 2: M-Z*, 3–9
    - SHOW, *Vol 2: M-Z*, 3–13
  - description, *Vol 2: M-Z*, 3–1
  - exiting, *Vol 2: M-Z*, 3–2
  - overview, *Vol 2: M-Z*, 3–1
- POOLCHECK system parameter, *Vol 2: M-Z*, D–46
- POOLPAGING system parameter, *Vol 2: M-Z*, D–46
- Ports
  - application, *Vol 1: A-L*, 14–10, 14–42, 14–43, 14–44, 14–60
  - characteristics, *Vol 1: A-L*, 14–60
  - counters, *Vol 1: A-L*, 14–60
  - creating with LATCP, *Vol 1: A-L*, 14–9
  - dedicated, *Vol 1: A-L*, 14–10, 14–42, 14–60
  - deleting with LATCP, *Vol 1: A-L*, 14–22
  - displaying characteristics of, *Vol 1: A-L*, 14–60
  - displaying information using LATCP, *Vol 1: A-L*, 14–60
  - limited, *Vol 1: A-L*, 14–10, 14–43
  - logical name of, *Vol 1: A-L*, 14–10
  - modifying characteristics of with LATCP, *Vol 1: A-L*, 14–42
  - name, *Vol 1: A-L*, 14–42
  - outgoing connection, *Vol 1: A-L*, 14–60
  - setting type of, *Vol 1: A-L*, 14–10
  - target, *Vol 1: A-L*, 14–62
- Ports (cont'd)
  - outgoing connection, *Vol 1: A-L*, 14–60
  - setting type of, *Vol 1: A-L*, 14–10
  - target, *Vol 1: A-L*, 14–62
- POSITION command
  - in Audit Analysis utility, *Vol 1: A-L*, 4–36
- POWEROFF system parameter, *Vol 2: M-Z*, D–46
- PPP connections
  - establishing, *Vol 2: M-Z*, 3–3
  - setting characteristics, *Vol 2: M-Z*, 3–9
  - terminating, *Vol 2: M-Z*, 3–6
  - viewing characteristics, *Vol 2: M-Z*, 3–13
- PPPD
  - See Point-to-Point Protocol utility
- PQL system parameters
  - PQL\_DASTLM, *Vol 2: M-Z*, D–46
  - PQL\_DBIOLM, *Vol 2: M-Z*, D–47
  - PQL\_DBYTLM, *Vol 2: M-Z*, D–47
  - PQL\_DCPULM, *Vol 2: M-Z*, D–47
  - PQL\_DDIOLM, *Vol 2: M-Z*, D–47
  - PQL\_DENQLM, *Vol 2: M-Z*, D–47
  - PQL\_DFILLM, *Vol 2: M-Z*, D–47
  - PQL\_DJTQUOTA, *Vol 2: M-Z*, D–47
  - PQL\_DPGFLQUOTA, *Vol 2: M-Z*, D–47
  - PQL\_DPRCLM, *Vol 2: M-Z*, D–47
  - PQL\_DTQELM, *Vol 2: M-Z*, D–47
  - PQL\_DWSDEFAULT, *Vol 2: M-Z*, D–47
  - PQL\_DWSEXTENT, *Vol 2: M-Z*, D–48
  - PQL\_DWSQUOTA, *Vol 2: M-Z*, D–48
  - PQL\_MASTLM, *Vol 2: M-Z*, D–48
  - PQL\_MBIOLM, *Vol 2: M-Z*, D–48
  - PQL\_MBYTLM, *Vol 2: M-Z*, D–48
  - PQL\_MCPULM, *Vol 2: M-Z*, D–48
  - PQL\_MDIOLM, *Vol 2: M-Z*, D–48
  - PQL\_MENQLM, *Vol 2: M-Z*, D–48
  - PQL\_MFILLM, *Vol 2: M-Z*, D–48
  - PQL\_MJTQUOTA, *Vol 2: M-Z*, D–48
  - PQL\_MPGFLQUOTA, *Vol 2: M-Z*, D–48
  - PQL\_MPRCLM, *Vol 2: M-Z*, D–49
  - PQL\_MTQELM, *Vol 2: M-Z*, D–49
  - PQL\_MWSDEFAULT, *Vol 2: M-Z*, D–49
  - PQL\_MWSEXTENT, *Vol 2: M-Z*, D–49
  - PQL\_MWSQUOTA, *Vol 2: M-Z*, D–49
- See also System parameters
  - process limits and quotas
- PRCPOLINTERVAL system parameter, *Vol 2: M-Z*, D–49
- Prefix list
  - displaying on Alpha and Integrity servers, *Vol 2: M-Z*, 9–92
  - setting on Alpha and Integrity servers, *Vol 2: M-Z*, 9–86
- Printers
  - configuring in a LAT environment, *Vol 1: A-L*, 14–10, 14–42



- PRIORITY\_OFFSET system parameter, *Vol 2: M-Z*, D-49
  - Privileges
    - assigning to installed images, *Vol 1: A-L*, 12-7, 12-23
    - assigning to known images, *Vol 1: A-L*, 12-8, 12-23
    - displaying current, *Vol 2: M-Z*, 9-125
    - modifying for environment, *Vol 2: M-Z*, 9-121
    - required by ACL editor, *Vol 1: A-L*, 1-2
    - required by SYSMAN, *Vol 2: M-Z*, 9-3
    - to perform BACKUP operations, *Vol 1: A-L*, 7-12
  - Process activity statistics
    - in Monitor utility, *Vol 2: M-Z*, 1-50
  - Processes
    - granting identifiers to, *Vol 1: A-L*, 1-14
    - hibernating
      - with ATTACH command, *Vol 2: M-Z*, 9-15
    - switching control of input stream to, *Vol 2: M-Z*, 9-15
    - transferring control from, *Vol 1: A-L*, 14-4
  - PROCESSES class record
    - in Monitor utility, *Vol 2: M-Z*, A-28
  - Processor modes statistics
    - in Monitor utility, *Vol 2: M-Z*, 1-42
  - Process states statistics
    - in Monitor utility, *Vol 2: M-Z*, 1-66
  - Process types
    - with Accounting utility, *Vol 1: A-L*, 2-21
  - PROCSCTCNT system parameter, *Vol 2: M-Z*, D-49
  - PRODUCT command, *Vol 2: M-Z*, 4-1
    - ANALYZE PDB subcommand, *Vol 2: M-Z*, 4-4
    - CONFIGURE subcommand, *Vol 2: M-Z*, 4-6
    - COPY subcommand, *Vol 2: M-Z*, 4-10
    - DELETE RECOVERY\_DATA subcommand, *Vol 2: M-Z*, 4-15
    - EXTRACT FILE subcommand, *Vol 2: M-Z*, 4-17
    - EXTRACT PDF subcommand, *Vol 2: M-Z*, 4-21
    - EXTRACT PTF subcommand, *Vol 2: M-Z*, 4-25
    - EXTRACT RELEASE\_NOTES subcommand, *Vol 2: M-Z*, 4-29
    - FIND subcommand, *Vol 2: M-Z*, 4-33
    - INSTALL subcommand, *Vol 2: M-Z*, 4-36
    - LIST subcommand, *Vol 2: M-Z*, 4-42
    - PACKAGE subcommand, *Vol 2: M-Z*, 4-46
    - RECONFIGURE subcommand, *Vol 2: M-Z*, 4-51
    - REGISTER PRODUCT subcommand, *Vol 2: M-Z*, 4-57
    - REGISTER VOLUME subcommand, *Vol 2: M-Z*, 4-62
    - REMOVE subcommand, *Vol 2: M-Z*, 4-64
    - SHOW HISTORY subcommand, *Vol 2: M-Z*, 4-66
  - PRODUCT command (cont'd)
    - SHOW OBJECT subcommand, *Vol 2: M-Z*, 4-69
    - SHOW PRODUCT subcommand, *Vol 2: M-Z*, 4-72
    - SHOW RECOVERY\_DATA subcommand, *Vol 2: M-Z*, 4-75
    - SHOW UTILITY subcommand, *Vol 2: M-Z*, 4-77
  - Product configuration files
    - See PCFs
  - Product database
    - ANALYZE PDB subcommand, *Vol 2: M-Z*, 4-4
  - Product description files
    - See PDFs
  - Product text files
    - See PTFs
  - Profiles, *Vol 2: M-Z*, 9-119
    - adjusting, *Vol 2: M-Z*, 9-121
    - displaying, *Vol 2: M-Z*, 9-125
    - in SYSMAN, *Vol 2: M-Z*, 9-67
  - /PROGRESS\_REPORT qualifier
    - in Backup utility, *Vol 1: A-L*, 7-79
  - Protection codes
    - propagating UIC-based protection in a directory tree, *Vol 1: A-L*, 1-10
  - /PROTECTION qualifier
    - in Backup utility, *Vol 1: A-L*, 7-80
  - Protocol bit mask
    - error definitions, *Vol 1: A-L*, 14-57
  - Proxy accounts
    - adding, *Vol 1: A-L*, 5-21
    - deleting, *Vol 1: A-L*, 5-79
    - modifying, *Vol 1: A-L*, 5-74
  - Proxy logins, *Vol 1: A-L*, 5-21, 5-74
  - PTFs (product text files)
    - of software products, *Vol 2: M-Z*, 4-25
  - PURGE command
    - in Install utility, *Vol 1: A-L*, 12-19
  - PURGE DEVICE command
    - in LANCP utility, *Vol 1: A-L*, 13-21
  - PURGE NODE command
    - in LANCP utility, *Vol 1: A-L*, 13-22
  - PU\_OPTIONS system parameter, *Vol 2: M-Z*, D-50
- ## Q
- 
- QDSKINTERVAL system parameter, *Vol 2: M-Z*, D-50
  - QDSKVOTES system parameter, *Vol 2: M-Z*, D-50
  - QUANTUM system parameter, *Vol 2: M-Z*, D-50
  - Quota file
    - creating, *Vol 2: M-Z*, 9-38
    - disabling, *Vol 2: M-Z*, 9-41
    - displaying, *Vol 2: M-Z*, 9-50
    - enabling, *Vol 2: M-Z*, 9-43

Quota file (cont'd)  
  modifying, *Vol 2: M-Z*, 9–45  
  removing an entry, *Vol 2: M-Z*, 9–40, 9–48  
  updating, *Vol 2: M-Z*, 9–47

## R

---

RAD example, *Vol 2: M-Z*, 9–151  
RAD\_SUPPORT system parameter, *Vol 2: M-Z*,  
  D–50  
Range checking  
  disabling, *Vol 2: M-Z*, 9–95  
  enabling, *Vol 2: M-Z*, 9–96  
READ FIRMWARE command  
  in MSA utility, *Vol 2: M-Z*, 2–13  
/READ\_CHECK qualifier, *Vol 1: A-L*, 3–13  
  in Analyze/Disk\_Structure utility, *Vol 1: A-L*,  
  3–13  
REBOOT phase of AUTOGEN, *Vol 1: A-L*, 6–8  
Rebuilding configuration tables  
  on Alpha and Integrity servers, *Vol 2: M-Z*,  
  9–81  
RECALL command  
  in LATCP, *Vol 1: A-L*, 14–27  
RECNXINTERVAL system parameter, *Vol 2:*  
  *M-Z*, D–51  
RECONFIGURE command  
  in PCSI, *Vol 2: M-Z*, 4–51  
Recording files  
  class types, *Vol 2: M-Z*, A–8  
  in Monitor utility  
    class header, *Vol 2: M-Z*, A–9  
    class prefix for component classes, *Vol 2:*  
    *M-Z*, A–10  
    class records, *Vol 2: M-Z*, A–8  
    data block, *Vol 2: M-Z*, A–11  
    description, *Vol 2: M-Z*, A–1  
    file header record, *Vol 2: M-Z*, A–4  
    HP control records, *Vol 2: M-Z*, A–3  
    I/O class record, *Vol 2: M-Z*, A–20  
    node transition record, *Vol 2: M-Z*, A–7  
    RLOCK class record, *Vol 2: M-Z*, A–30  
    RMS class record, *Vol 2: M-Z*, A–31  
    RMS file record, *Vol 2: M-Z*, A–7  
    SCS class record, *Vol 2: M-Z*, A–32  
    system information record, *Vol 2: M-Z*,  
    A–6  
/RECORD qualifier  
  in Backup utility, *Vol 1: A-L*, 7–82  
  in Monitor utility, *Vol 2: M-Z*, 1–15  
Records  
  See also Security audit log files  
  duplicating, *Vol 1: A-L*, 5–23  
Record types  
  in Monitor utility, *Vol 2: M-Z*, A–2  
/RECORD\_ATTRIBUTES qualifier  
  in Analyze/Disk\_Structure utility, *Vol 1: A-L*,  
  3–14

Recovering lost files, *Vol 1: A-L*, 3–3  
REFRESH command  
  in LATCP, *Vol 1: A-L*, 14–28  
  in Show Cluster utility, *Vol 2: M-Z*, 7–49  
REGISTER PRODUCT command  
  in PCSI, *Vol 2: M-Z*, 4–57  
REGISTER VOLUME command  
  in PCSI, *Vol 2: M-Z*, 4–62  
Release Notes  
  on software products, *Vol 2: M-Z*, 4–29  
/RELEASE\_TAPE qualifier  
  in Backup utility, *Vol 1: A-L*, 7–83  
RELOAD command  
  in UCM, *Vol 2: M-Z*, 10–21  
Remote nodes  
  creating MONITOR\_SERVER process on, *Vol*  
  2: *M-Z*, 1–20  
REMOVE (Field) command  
  in Show Cluster utility, *Vol 2: M-Z*, 7–57  
REMOVE/IDENTIFIER command  
  in Authorize utility, *Vol 1: A-L*, 5–78  
REMOVE/PROXY command  
  in Authorize utility, *Vol 1: A-L*, 5–79  
REMOVE CIRCUITS command  
  in Show Cluster utility, *Vol 2: M-Z*, 7–50  
REMOVE CLUSTER command  
  in Show Cluster utility, *Vol 2: M-Z*, 7–51  
REMOVE command  
  in Authorize utility, *Vol 1: A-L*, 5–77  
  in Install utility, *Vol 1: A-L*, 12–20  
  in PCSI, *Vol 2: M-Z*, 4–64  
REMOVE CONNECTIONS command  
  in Show Cluster utility, *Vol 2: M-Z*, 7–52  
REMOVE COUNTERS command  
  in Show Cluster utility, *Vol 2: M-Z*, 7–54  
REMOVE CREDITS command  
  in Show Cluster utility, *Vol 2: M-Z*, 7–55  
REMOVE ERRORS command  
  in Show Cluster utility, *Vol 2: M-Z*, 7–56  
REMOVE LOCAL\_PORTS command  
  in Show Cluster utility, *Vol 2: M-Z*, 7–58  
REMOVE MEMBERS command  
  in Show Cluster utility, *Vol 2: M-Z*, 7–59  
REMOVE SYSTEMS command  
  in Show Cluster utility, *Vol 2: M-Z*, 7–60  
Removing installed software products, *Vol 2: M-Z*,  
  4–64  
RENAME/IDENTIFIER command  
  in Authorize utility, *Vol 1: A-L*, 5–83  
RENAME command  
  in Authorize utility, *Vol 1: A-L*, 5–80  
REPAIR command  
  in LMCP, *Vol 1: A-L*, 15–15  
Repairing errors, *Vol 1: A-L*, 3–2, 3–8, 3–9, 3–14,  
  3–15  
/REPAIR qualifier  
  in Analyze/Disk\_Structure utility, *Vol 1: A-L*,  
  3–15

/REPAIR qualifier (cont'd)  
 in Backup utility, *Vol 1: A-L*, 7–84

REPLACE command  
 in Install utility, *Vol 1: A-L*, 12–21

/REPLACE qualifier  
 in Backup utility, *Vol 1: A-L*, 7–85

Report formats from Audit Analysis utility  
 brief, *Vol 1: A-L*, 4–6  
 full, *Vol 1: A-L*, 4–9  
 summary, *Vol 1: A-L*, 4–25

Reporting errors, *Vol 1: A-L*, 3–2

Reports  
 SHOW CLUSTER, *Vol 2: M-Z*, 7–10  
 command to modify, *Vol 2: M-Z*, C–3  
 controlling displays, *Vol 2: M-Z*, 7–10,  
 7–11  
 default display, *Vol 2: M-Z*, 7–44  
 formatting, *Vol 2: M-Z*, 7–68  
 organization of, *Vol 2: M-Z*, 7–1  
 printing, *Vol 2: M-Z*, 7–72  
 time period for, *Vol 2: M-Z*, 7–13, 7–15  
 update interval, *Vol 2: M-Z*, 7–16, 7–70

Requirements and limitations  
 in ANALYZE/DISK\_STRUCTURE, *Vol 1: A-L*,  
 3–6

RESALLOC system parameter, *Vol 2: M-Z*, D–51

Reserved Memory Registry  
 adding an entry, *Vol 2: M-Z*, 9–105  
 adding RADs to a reservation, *Vol 2: M-Z*,  
 9–109  
 AUTOGEN processes, *Vol 2: M-Z*, 9–105  
 commands, *Vol 2: M-Z*, 9–105 to 9–118  
 modifying an existing entry, *Vol 2: M-Z*, 9–113  
 previews reservation, *Vol 2: M-Z*, 9–112  
 removing an entry, *Vol 2: M-Z*, 9–116

RESERVED\_MEMORY commands  
 in SYSMAN, *Vol 2: M-Z*, 9–105

RESERVED\_MEMORY\_EXTEND command, *Vol 2:*  
*M-Z*, 9–109

RESERVED\_MEMORY\_FREE command, *Vol 2:*  
*M-Z*, 9–110

RESERVED\_MEMORY\_LIST command, *Vol 2:*  
*M-Z*, 9–112

RESERVED\_MEMORY\_MODIFY command, *Vol 2:*  
*M-Z*, 9–113

RESERVED\_MEMORY\_REMOVE command, *Vol 2:*  
*M-Z*, 9–116

RESERVED\_MEMORY\_SHOW command, *Vol 2:*  
*M-Z*, 9–117

RESET\_OTHER\_CONTROLLER command  
 in MSA utility, *Vol 2: M-Z*, 2–15

RESET\_THIS\_CONTROLLER command  
 in MSA utility, *Vol 2: M-Z*, 2–14

RESHASHTBL system parameter, *Vol 2: M-Z*,  
 D–51

Resource accounting  
 programming information, *Vol 1: A-L*, C–1

Resource attributes, *Vol 1: A-L*, 5–19, 5–50, 5–72

Resource use  
 producing reports of, *Vol 1: A-L*, 2–8, 2–11,  
 2–32

RESTART command  
 in UCM, *Vol 2: M-Z*, 10–22

Retransmit limit, *Vol 1: A-L*, 14–36

REVOKE/IDENTIFIER command  
 in Authorize utility, *Vol 1: A-L*, 5–84

/REWIND qualifier  
 as Backup utility input save-set qualifier, *Vol 1:*  
*A-L*, 7–86  
 as Backup utility output save-set qualifier, *Vol 1:*  
*A-L*, 7–87

Rights databases  
 See RIGHTSLLIST.DAT files

Rights identifier, *Vol 2: M-Z*, 9–45  
 for disk quota file, *Vol 2: M-Z*, 9–36

RIGHTSLLIST.DAT files  
 adding identifiers to, *Vol 1: A-L*, 5–19  
 altering identifiers in, *Vol 1: A-L*, 5–72  
 creating and maintaining, *Vol 1: A-L*, 5–1,  
 5–36  
 deleting identifiers from, *Vol 1: A-L*, 5–78  
 displaying identifiers in, *Vol 1: A-L*, 5–90  
 displaying records in, *Vol 1: A-L*, 5–94  
 renaming identifiers, *Vol 1: A-L*, 5–83

RJOBLIM system parameter, *Vol 2: M-Z*, D–51

RLOCK class record  
 in Monitor utility, *Vol 2: M-Z*, A–30

RMS class record  
 in Monitor utility, *Vol 2: M-Z*, A–31

RMS statistics  
 in Monitor utility, *Vol 2: M-Z*, 1–58

RMS system parameters  
 RMSD\*, *Vol 2: M-Z*, D–52  
 RMS\_CONPOLICY, *Vol 2: M-Z*, D–51  
 RMS\_DFLRL, *Vol 2: M-Z*, D–52  
 RMS\_DFMBC, *Vol 2: M-Z*, D–52  
 RMS\_DFMBFIDX, *Vol 2: M-Z*, D–52  
 RMS\_DFMBFREL, *Vol 2: M-Z*, D–52  
 RMS\_DFMBFSDK, *Vol 2: M-Z*, D–52  
 RMS\_DFMBFSMT, *Vol 2: M-Z*, D–53  
 RMS\_DFMBFSUR, *Vol 2: M-Z*, D–53  
 RMS\_DFNBC, *Vol 2: M-Z*, D–53  
 RMS\_EXTEND\_SIZE, *Vol 2: M-Z*, D–53  
 RMS\_FILEPROT, *Vol 2: M-Z*, D–54  
 RMS\_HEURISTIC, *Vol 2: M-Z*, D–54  
 RMS\_PATH\_TMO, *Vol 2: M-Z*, D–54  
 RMS\_PROLOGUE, *Vol 2: M-Z*, D–54  
 RMS\_SEQFILE\_WBH, *Vol 2: M-Z*, D–54

## S

S0\_PAGING system parameter, *Vol 2: M-Z, D-54*

S2\_SIZE system parameter, *Vol 2: M-Z, D-55*

SAS Controller

commands

ADD UNIT, *Vol 2: M-Z, 5-3*

DELETE DISK, *Vol 2: M-Z, 5-6*

DELETE UNIT, *Vol 2: M-Z, 5-7*

EXIT, *Vol 2: M-Z, 5-7*

SET CONTROLLER, *Vol 2: M-Z, 5-9*

SET DISK, *Vol 2: M-Z, 5-10*

SET UNIT, *Vol 2: M-Z, 5-11*

SHOW CONTROLLER, *Vol 2: M-Z, 5-13*

SHOW DISK, *Vol 2: M-Z, 5-14*

SHOW ENCLOSURE, *Vol 2: M-Z, 5-15*

SHOW EXPANDER, *Vol 2: M-Z, 5-16*

SHOW PHY, *Vol 2: M-Z, 5-17*

SHOW UNIT, *Vol 2: M-Z, 5-18*

SHOW VERSION, *Vol 2: M-Z, 5-19*

description, *Vol 2: M-Z, 5-1*

privileges required, *Vol 2: M-Z, 5-2*

restrictions, *Vol 2: M-Z, 5-2*

usage summary, *Vol 2: M-Z, 5-2*

utility SAS\$UTIL, *Vol 2: M-Z, 5-2*

SAVE command

in InfoServer utility, *Vol 1: A-L, 11-12*

in Show Cluster utility, *Vol 2: M-Z, 7-62*

SAVEDUMP system parameter, *Vol 2: M-Z, D-55*

Save sets

description of, *Vol 1: A-L, 7-1*

directing output to, *Vol 1: A-L, 7-12*

encrypting, *Vol 1: A-L, 7-36*

Save-set specification, *Vol 1: A-L, 7-3*

/SAVE\_SET qualifier

as Backup utility input save-set qualifier, *Vol 1: A-L, 7-90*

as Backup utility output save-set qualifier, *Vol 1: A-L, 7-91*

of BACKUP command, *Vol 1: A-L, 7-37*

SAVPARAMS phase of AUTOGEN, *Vol 1: A-L, 6-6*

SCA (Systems Communications Architecture)

in SCACP utility, *Vol 2: M-Z, 6-1*

paths (equivalent to circuits), *Vol 2: M-Z, 6-2*

SCA Control Program (SCACP)

commands, *Vol 2: M-Z, 6-6*

CALCULATE WINDOW\_SIZE, *Vol 2: M-Z, 6-9*

EXIT, *Vol 2: M-Z, 6-10*

HELP, *Vol 2: M-Z, 6-11*

RELOAD, *Vol 2: M-Z, 6-12*

SET CHANNEL, *Vol 2: M-Z, 6-9, 6-13*

SET CIRCUIT, *Vol 2: M-Z, 6-15*

SET IP\_INTERFACE, *Vol 2: M-Z, 6-16*

SET LAN\_DEVICE, *Vol 2: M-Z, 6-17*

SET PORT, *Vol 2: M-Z, 6-18*

SCA Control Program (SCACP)

commands (cont'd)

SET TRACE, *Vol 2: M-Z, 6-19*

SET VC, *Vol 2: M-Z, 6-21*

SHOW CHANNEL, *Vol 2: M-Z, 6-25*

SHOW CIRCUIT, *Vol 2: M-Z, 6-31*

SHOW IP\_INTERFACE, *Vol 2: M-Z, 6-33*

SHOW LAN\_DEVICE, *Vol 2: M-Z, 6-36*

SHOW PORT, *Vol 2: M-Z, 6-38*

SHOW TRACE, *Vol 2: M-Z, 6-39*

SHOW VC, *Vol 2: M-Z, 6-42*

SPAWN, *Vol 2: M-Z, 6-44*

START IP\_INTERFACE, *Vol 2: M-Z, 6-45*

START LAN\_DEVICE, *Vol 2: M-Z, 6-46*

START TRACE, *Vol 2: M-Z, 6-47*

STOP IP\_INTERFACE, *Vol 2: M-Z, 6-49*

STOP LAN\_DEVICE, *Vol 2: M-Z, 6-50*

STOP TRACE, *Vol 2: M-Z, 6-51*

event tracing, *Vol 2: M-Z, 6-5*

invoking, *Vol 2: M-Z, 6-6*

LAN channels, *Vol 2: M-Z, 6-2, 6-3*

LAN circuits, *Vol 2: M-Z, 6-2*

LAN cluster ports, *Vol 2: M-Z, 6-5*

PEdriver (IP cluster driver), *Vol 2: M-Z, 6-3*

PEdriver (LAN cluster driver), *Vol 2: M-Z, 6-2*

privileges required, *Vol 2: M-Z, 6-6*

terminology

SCA, *Vol 2: M-Z, 6-1*

troubleshooting with, *Vol 2: M-Z, 6-5*

virtual circuits, *Vol 2: M-Z, 6-2*

SCAN ALL command

in MSA utility, *Vol 2: M-Z, 2-16*

SCBs (storage control blocks)

updating, *Vol 1: A-L, 3-2*

Scheduling classes

creating, *Vol 2: M-Z, 9-17*

deleting, *Vol 2: M-Z, 9-22*

displaying, *Vol 2: M-Z, 9-26*

modifying characteristics, *Vol 2: M-Z, 9-23*

resuming suspended classes, *Vol 2: M-Z, 9-25*

suspending temporarily, *Vol 2: M-Z, 9-27*

SCHED\_FLAGS system parameter, *Vol 2: M-Z, D-55*

SCH\_HARD\_OFFFLD system parameter, *Vol 2: M-Z, D-55*

SCH\_SOFT\_OFFFLD system parameter, *Vol 2: M-Z, D-55*

Screens

refreshing from LATCP, *Vol 1: A-L, 14-28*

SCROLL command

in LATCP, *Vol 1: A-L, 14-29*

in Show Cluster utility, *Vol 2: M-Z, 7-64*

SCROLL keypad function, *Vol 2: M-Z, C-3*

SCS (Systems Communications Services)

circuits and ports in SCACP utility, *Vol 2: M-Z, 6-1*

SHOW CLUSTER information, *Vol 2: M-Z, 7-1*



- SCS class record
  - in Monitor utility, *Vol 2: M-Z, A-32*
- SCSICLUSTER\_P[1-4] system parameter, *Vol 2: M-Z, D-56*
- SCSI\_ERROR\_POLL system parameter, *Vol 2: M-Z, D-56*
- SCS statistics
  - in Monitor utility, *Vol 2: M-Z, 1-62*
- SCSSYSTEMID system parameter
  - and LATCP CREATE LINK command, *Vol 1: A-L, 14-6*
- SCS system parameters
  - SCSBUFFCNT, *Vol 2: M-Z, D-55*
  - SCSFLOWCUSH, *Vol 2: M-Z, D-55*
  - SCSMAXDG, *Vol 2: M-Z, D-56*
  - SCSMAXMSG, *Vol 2: M-Z, D-56*
  - SCSNODE, *Vol 2: M-Z, D-56*
  - SCSRESPCNT, *Vol 2: M-Z, D-56*
  - SCSSYSTEMID, *Vol 2: M-Z, D-57*
  - SCSSYSTEMIDH, *Vol 2: M-Z, D-57*
- SECAUDIT.COM command procedure
  - See Audit Analysis utility
- Security Alarm ACEs
  - See Alarm ACEs
- Security alarm messages
  - specifying access criteria for, *Vol 1: A-L, 1-4, 1-6*
- Security archive files, analyzing, *Vol 1: A-L, 4-2*
- Security Audit ACEs
  - See Audit ACEs
- Security audit data packets
  - fields, *Vol 1: A-L, F-7*
  - format, *Vol 1: A-L, F-6*
- Security audit event messages
  - data packets in, *Vol 1: A-L, F-6*
  - event flags, *Vol 1: A-L, F-6*
  - extracting from log files, *Vol 1: A-L, 4-1*
  - format, *Vol 1: A-L, F-1*
  - subtypes for events, *Vol 1: A-L, F-2*
  - types of events, *Vol 1: A-L, F-2*
- Security audit header packets, *Vol 1: A-L, F-2*
- Security audit log files
  - advancing to next record, *Vol 1: A-L, 4-36*
  - analyzing, *Vol 1: A-L, 4-1, 4-2*
  - data packet format, *Vol 1: A-L, F-6*
  - displaying records, *Vol 1: A-L, 4-29*
  - displaying the full record, *Vol 1: A-L, 4-9*
  - excluding information from reports, *Vol 1: A-L, 4-10*
  - header packet format, *Vol 1: A-L, F-1*
  - opening new input file, *Vol 1: A-L, 4-34*
  - resuming processing, *Vol 1: A-L, 4-28*
  - returning to previous record, *Vol 1: A-L, 4-36*
  - selecting records by event class, *Vol 1: A-L, 4-7*
  - selecting records by time, *Vol 1: A-L, 4-4, 4-24*
- Security audit log files (cont'd)
  - specifying duration of record display, *Vol 1: A-L, 4-13*
  - writing alarm messages to, *Vol 1: A-L, 1-6*
- Security audit records
  - criteria for selecting, *Vol 1: A-L, 4-14*
- Security audit reports, *Vol 1: A-L, 4-1 to 4-37*
  - advancing the display, *Vol 1: A-L, 4-35*
  - binary output, *Vol 1: A-L, 4-5*
  - brief format, *Vol 1: A-L, 4-6*
  - creating, *Vol 1: A-L, 4-1*
  - directing output, *Vol 1: A-L, 4-12*
  - displaying selection criteria, *Vol 1: A-L, 4-37*
  - duration of record display, *Vol 1: A-L, 4-13*
  - excluding information, *Vol 1: A-L, 4-10*
  - full format, *Vol 1: A-L, 4-9*
  - interrupting the display, *Vol 1: A-L, 4-27*
  - modifying selection criteria, *Vol 1: A-L, 4-29*
  - processing additional log files, *Vol 1: A-L, 4-34*
  - resuming the processing, *Vol 1: A-L, 4-27*
  - summary of records, *Vol 1: A-L, 4-25*
- Security event classes
  - extracting audit records by, *Vol 1: A-L, 4-7*
- Security objects
  - classes, *Vol 1: A-L, 1-2*
- Security operators
  - sending alarm messages to audit log files, *Vol 1: A-L, 1-6*
  - sending alarm messages to terminals, *Vol 1: A-L, 1-4*
- SECURITY\_POLICY system parameter, *Vol 2: M-Z, D-57*
- SELECT command
  - in Show Cluster utility, *Vol 2: M-Z, 7-66*
- /SELECT qualifier
  - in Backup utility, *Vol 1: A-L, 7-92*
- Serial Attached SCSI (SAS) Utility
  - ADD UNIT command, *Vol 2: M-Z, 5-4*
- Service node, *Vol 1: A-L, 14-1*
  - controlling access to, *Vol 1: A-L, 14-34, 14-39*
  - deleting a port, *Vol 1: A-L, 14-22*
  - modifying characteristics of, *Vol 1: A-L, 14-32, 14-46*
  - naming, *Vol 1: A-L, 14-43*
  - service announcements, *Vol 1: A-L, 14-35, 14-36*
- Services
  - application, *Vol 1: A-L, 14-10, 14-14, 14-16, 14-42, 14-46*
  - creating with LATCP, *Vol 1: A-L, 14-14*
  - database, *Vol 1: A-L, 14-36, 14-39*
  - deleting with LATCP, *Vol 1: A-L, 14-24*
  - displaying characteristics of, *Vol 1: A-L, 14-66*
  - displaying counters, *Vol 1: A-L, 14-65*
  - displaying information using LATCP, *Vol 1: A-L, 14-65*
  - general timesharing, *Vol 1: A-L, 14-16*
  - identifier, *Vol 1: A-L, 14-14, 14-35, 14-46*

## Services (cont'd)

- limiting size of node database, *Vol 1: A-L*, 14–36, 14–39
- modifying characteristics of, *Vol 1: A-L*, 14–46
- naming with LATCP, *Vol 1: A-L*, 14–14, 14–30
- rating, *Vol 1: A-L*, 14–15, 14–47, 14–58, 14–66
- responder, *Vol 1: A-L*, 14–37
- target, *Vol 1: A-L*, 14–62

Session limit, *Vol 1: A-L*, 14–37

Sessions

- terminating, *Vol 1: A-L*, 3–6

SET/OUTPUT command

- in SYSGEN, *Vol 2: M-Z*, 8–9

SET/STARTUP command

- in SYSGEN, *Vol 2: M-Z*, 8–10

SET ACP command

- in LANCP utility, *Vol 1: A-L*, 13–23

SET AUDIT command

- recording alarm messages, *Vol 1: A-L*, 1–6

SET AUTO command

- in UCM, *Vol 2: M-Z*, 10–23

SET AUTO\_POSITIONING command

- in Show Cluster utility, *Vol 2: M-Z*, 7–67

SET command

- (Field), *Vol 2: M-Z*, 7–68
- in Point-to-Point Protocol utility, *Vol 2: M-Z*, 3–9
- in SYSGEN, *Vol 2: M-Z*, 8–8

SET CONTROLLER

- in MSA utility, *Vol 2: M-Z*, 2–17

SET DEFAULT command, *Vol 2: M-Z*, 1–81

- in Monitor utility, *Vol 2: M-Z*, 1–81

SET DEVICE command

- in LANCP utility, *Vol 1: A-L*, 13–24

SET ENVIRONMENT command

- in SYSMAN, *Vol 2: M-Z*, 9–119

SET FUNCTION command, *Vol 2: M-Z*, C–3

- in Show Cluster utility, *Vol 2: M-Z*, 7–69

SET GLOBALS

- in MSA utility, *Vol 2: M-Z*, 2–18

SET INTERVAL command

- in Show Cluster utility, *Vol 2: M-Z*, 7–70

SET LINK command

- in LATCP, *Vol 1: A-L*, 14–30

SET LOG command

- in UCM, *Vol 2: M-Z*, 10–25

SET NODE command

- in LANCP utility, *Vol 1: A-L*, 13–35
- in LATCP, *Vol 1: A-L*, 14–32

SETPARAMS.DAT file, *Vol 1: A-L*, 6–7, 6–8

SETPARAMS phase of AUTOGEN, *Vol 1: A-L*, 6–8

SET PORT command

- in LATCP, *Vol 1: A-L*, 14–42

SET PROFILE command

- in SYSMAN, *Vol 2: M-Z*, 9–121

## SET QUORUM command

- avoiding use of /CLUSTER with SYSMAN DO command, *Vol 2: M-Z*, 9–52

## SET SCREEN command

- in Show Cluster utility, *Vol 2: M-Z*, 7–71

## SET SECURITY/EDIT command, *Vol 1: A-L*, 1–2, 1–16

## SET SECURITY command

- /CLASS qualifier, *Vol 1: A-L*, 1–2

- specifying object class, *Vol 1: A-L*, 1–2

## SET SERVICE command

- in InfoServer utility, *Vol 1: A-L*, 11–15

- in LATCP, *Vol 1: A-L*, 14–46

## SET TIMEOUT command

- in SYSMAN, *Vol 2: M-Z*, 9–122

## SETTIME system parameter, *Vol 2: M-Z*, D–58

## Setting page, swap, and dump file sizes, *Vol 1: A-L*, 6–1

## SET UNIT command

- in MSA utility, *Vol 2: M-Z*, 2–20

## SHADOWING system parameter, *Vol 2: M-Z*, D–58

## /SHADOW qualifier

- in Analyze/Disk\_Structure utility, *Vol 1: A-L*, 3–16

## Shadow sets

- detecting errors, *Vol 1: A-L*, 3–17

- examining, *Vol 1: A-L*, 3–16

- maximum number of, *Vol 2: M-Z*, D–59

## SHADOW\_D1-D5 system parameter, *Vol 2: M-Z*, D–58

## SHADOW\_ENABLE system parameter, *Vol 2: M-Z*, D–58

## SHADOW\_HBMM\_RTC system parameter, *Vol 2: M-Z*, D–59

## SHADOW\_MAX\_COPY system parameter, *Vol 2: M-Z*, D–59

## SHADOW\_MAX\_UNIT system parameter, *Vol 2: M-Z*, D–59

## SHADOW\_MBR\_TMO system parameter, *Vol 2: M-Z*, D–60

## SHADOW\_PSM\_RDLY system parameter, *Vol 2: M-Z*, D–60

## SHADOW\_REC\_DLY system parameter, *Vol 2: M-Z*, D–60

## SHADOW\_SYS\_DISK system parameter, *Vol 2: M-Z*, D–61

## SHADOW\_SYS\_TMO system parameter, *Vol 2: M-Z*, D–61

## SHADOW\_SYS\_UNIT system parameter, *Vol 2: M-Z*, D–61

## SHADOW\_SYS\_WAIT system parameter, *Vol 2: M-Z*, D–62

## SHOW/IDENTIFIER command

- in Authorize utility, *Vol 1: A-L*, 5–90

## SHOW/PROXY command

- in Authorize utility, *Vol 1: A-L*, 5–92

SHOW/RIGHTS command  
 in Authorize utility, *Vol 1: A-L*, 5–94

SHOW/STARTUP command, *Vol 2: M-Z*, 8–16

SHOW ACP command  
 in LANCP utility, *Vol 1: A-L*, 13–39

SHOW AUTO command  
 in UCM, *Vol 2: M-Z*, 10–26

SHOW CLUSTER command  
 initialization file, *Vol 2: M-Z*, 7–11  
 in Show Cluster utility, *Vol 2: M-Z*, 7–11  
 keypad commands, *Vol 2: M-Z*, 7–11

Show Cluster utility (SHOW CLUSTER)  
 See also Reports, SHOW CLUSTER  
 activation time, *Vol 2: M-Z*, 7–13, 7–15, 7–16, 7–70  
 classes of data, *Vol 2: M-Z*, 7–1  
 commands, *Vol 2: M-Z*, 7–17  
 continuous mode, *Vol 2: M-Z*, 7–11, 7–14  
 controlling displays, *Vol 2: M-Z*, 7–10  
 data fields, *Vol 2: M-Z*, 7–1  
 defining arrow keys, *Vol 2: M-Z*, C–3  
 defining keypad keys, *Vol 2: M-Z*, 7–38, C–3  
 deselecting window, *Vol 2: M-Z*, 7–41  
 directing output, *Vol 2: M-Z*, 7–11  
 Execute Procedure (@) command, *Vol 2: M-Z*, 7–20  
 exiting, *Vol 2: M-Z*, 7–12, 7–42  
 invoking, *Vol 2: M-Z*, 7–11  
 keypad, *Vol 2: M-Z*, C–1  
 moving display window, *Vol 2: M-Z*, 7–45, 7–66  
 /OUTPUT qualifier, *Vol 2: M-Z*, 7–11  
 panning display window, *Vol 2: M-Z*, 7–47  
 qualifiers, *Vol 2: M-Z*, 7–12  
 refreshing the display, *Vol 2: M-Z*, 7–49  
 removing display information, *Vol 2: M-Z*, 7–50 to 7–60  
 resetting display information, *Vol 2: M-Z*, 7–44  
 sample display, *Vol 2: M-Z*, 7–10  
 scrolling display window, *Vol 2: M-Z*, 7–47, 7–66  
 selecting display fields, *Vol 2: M-Z*, 7–31  
 CIRCUITS class, *Vol 2: M-Z*, 7–21  
 CLUSTER class, *Vol 2: M-Z*, 7–23  
 CONNECTIONS class, *Vol 2: M-Z*, 7–25  
 COUNTERS class, *Vol 2: M-Z*, 7–27  
 CREDITS class, *Vol 2: M-Z*, 7–29  
 ERRORS class, *Vol 2: M-Z*, 7–30  
 LOCAL\_PORTS class, *Vol 2: M-Z*, 7–33  
 MEMBERS class, *Vol 2: M-Z*, 7–35  
 SYSTEMS class, *Vol 2: M-Z*, 7–36  
 selecting display window, *Vol 2: M-Z*, 7–66

SHOW command  
 in Audit Analysis utility, *Vol 1: A-L*, 4–37  
 in Authorize utility, *Vol 1: A-L*, 5–85  
 in Point-to-Point Protocol utility, *Vol 2: M-Z*, 3–13  
 in SYSGEN, *Vol 2: M-Z*, 8–11

SHOW CONFIGURATION command  
 in LANCP utility, *Vol 1: A-L*, 13–40

SHOW CONNECTIONS command  
 in MSA utility, *Vol 2: M-Z*, 2–25

SHOW CONTROLLER command  
 in MSA utility, *Vol 2: M-Z*, 2–26

SHOW DEFAULT command  
 in Monitor utility, *Vol 2: M-Z*, 1–82

SHOW DEVICE command  
 in LANCP utility, *Vol 1: A-L*, 13–42  
 in UCM, *Vol 2: M-Z*, 10–27

SHOW DISKS command  
 in MSA utility, *Vol 2: M-Z*, 2–29

SHOW DLL command  
 in LANCP utility, *Vol 1: A-L*, 13–46

SHOW ENVIRONMENT command, *Vol 2: M-Z*, 9–119, 9–123  
 in SYSMAN, *Vol 2: M-Z*, 9–123

SHOW GLOBALS command  
 in MSA utility, *Vol 2: M-Z*, 2–32

SHOW HISTORY command  
 in PCSI, *Vol 2: M-Z*, 4–66

SHOW KEY command  
 in SYSMAN, *Vol 2: M-Z*, 9–124

SHOW LINK command  
 in LATCP, *Vol 1: A-L*, 14–49

SHOW LOG command  
 in LANCP utility, *Vol 1: A-L*, 13–47  
 in LMCP, *Vol 1: A-L*, 15–18

SHOW NODE command  
 in LANCP utility, *Vol 1: A-L*, 13–49  
 in LATCP, *Vol 1: A-L*, 14–54

SHOW OBJECT command  
 in PCSI, *Vol 2: M-Z*, 4–69

SHOW OTHER\_CONTROLLER command  
 in MSA utility, *Vol 2: M-Z*, 2–34

SHOW PORT command  
 in LATCP, *Vol 1: A-L*, 14–60

SHOW PRODUCT command  
 in PCSI, *Vol 2: M-Z*, 4–72

SHOW PROFILE command  
 in MSA utility, *Vol 2: M-Z*, 2–33  
 in SYSMAN, *Vol 2: M-Z*, 9–125

SHOW QUEUE\_ENTRY command  
 in LATCP, *Vol 1: A-L*, 14–63

SHOW RECOVERY\_DATA command  
 in PCSI, *Vol 2: M-Z*, 4–75

SHOW SERVER command  
 in InfoServer utility, *Vol 1: A-L*, 11–18

SHOW SERVICE command  
 in LATCP, *Vol 1: A-L*, 14–65

SHOW SERVICES command  
 in InfoServer utility, *Vol 1: A-L*, 11–19

SHOW SESSIONS command  
 in InfoServer utility, *Vol 1: A-L*, 11–21

SHOW THIS\_CONTROLLER command  
 in MSA utility, *Vol 2: M-Z*, 2–35

SHOW TIMEOUT command  
     in SYSMAN, *Vol 2: M-Z*, 9–126  
 SHOW UNIT command  
     in MSA utility, *Vol 2: M-Z*, 2–36  
 SHOW UNITS command  
     in MSA utility, *Vol 2: M-Z*, 2–37  
 SHOW UTILITY command  
     in PCSI, *Vol 2: M-Z*, 4–77  
 SHOW VERSION command  
     in MSA utility, *Vol 2: M-Z*, 2–38, 2–39  
 SHOW\_CLUSTER\$INIT:SHOW\_CLUSTER.INI  
     initialization file, *Vol 2: M-Z*, 7–11  
 SHOW\_CLUSTER\$INIT logical name, *Vol 2: M-Z*, 7–20  
 SHUTDOWN NODE command  
     in SYSMAN, *Vol 2: M-Z*, 9–127  
 SHUTDOWN phase of AUTOGEN, *Vol 1: A-L*, 6–8  
 /SINCE qualifier  
     in Backup utility, *Vol 1: A-L*, 7–93  
 /SIZE qualifier  
     in Backup utility, *Vol 1: A-L*, 7–95  
 SMCI\_FLAGS system parameter, *Vol 2: M-Z*, D–62  
 SMCI\_PORTS system parameter, *Vol 2: M-Z*, D–62  
 SMP\_CPU\_BITMAP system parameter, *Vol 2: M-Z*, D–62  
 SMP\_LNGSPINWAIT system parameter, *Vol 2: M-Z*, D–63  
 SMP\_SANITY\_CNT system parameter, *Vol 2: M-Z*, D–63  
 SMP\_SPINWAIT system parameter, *Vol 2: M-Z*, D–63  
 SMP\_TICK\_CNT system parameter, *Vol 2: M-Z*, D–63  
 Software  
     listing  
         PCSI, *Vol 2: M-Z*, 4–42  
 Software products  
     files of  
         deleting recovery data, *Vol 2: M-Z*, 4–15  
         extracting, *Vol 2: M-Z*, 4–17  
     removing, *Vol 2: M-Z*, 4–64  
 SPAWN command  
     and ATTACH command, *Vol 2: M-Z*, 9–15  
     in InfoServer utility, *Vol 1: A-L*, 11–23  
     in LANCP utility, *Vol 1: A-L*, 13–51  
     in LATCP, *Vol 1: A-L*, 14–68  
     in SYSMAN, *Vol 2: M-Z*, 9–131  
 SSINHIBIT system parameter, *Vol 2: M-Z*, D–64  
 SSI\_ENABLE system parameter, *Vol 2: M-Z*, D–63  
 Stage checks, *Vol 1: A-L*, D–1  
 Standalone BACKUP, *Vol 1: A-L*, 7–12  
 Start phase of AUTOGEN, *Vol 1: A-L*, 6–6  
     default, *Vol 1: A-L*, 6–10  
 START SERVER command  
     in InfoServer utility, *Vol 1: A-L*, 11–24  
 Startup  
     logging, *Vol 2: M-Z*, 9–144  
     phase, *Vol 2: M-Z*, 9–135  
     status, *Vol 2: M-Z*, 9–144  
 STARTUP\$STARTUP\_LAYERED logical name, *Vol 2: M-Z*, 9–143  
 STARTUP\$STARTUP\_VMS logical name, *Vol 2: M-Z*, 9–143  
 STARTUP ADD command  
     in SYSMAN, *Vol 2: M-Z*, 9–135  
 Startup command procedure, *Vol 2: M-Z*, 8–10, 8–17, 8–18  
     setting the name, *Vol 2: M-Z*, 9–97  
     site-independent file name, *Vol 2: M-Z*, 8–16  
 Startup database  
     establishing, *Vol 2: M-Z*, 9–143  
     files  
         adding, *Vol 2: M-Z*, 9–135  
         deleting, *Vol 2: M-Z*, 9–142  
         disabling, *Vol 2: M-Z*, 9–137  
         enabling, *Vol 2: M-Z*, 9–139  
         modifying, *Vol 2: M-Z*, 9–140  
         setting the default, *Vol 2: M-Z*, 9–143  
 STARTUP DISABLE command  
     in SYSMAN, *Vol 2: M-Z*, 9–137  
 STARTUP ENABLE command  
     in SYSMAN, *Vol 2: M-Z*, 9–139  
 STARTUP MODIFY command  
     in SYSMAN, *Vol 2: M-Z*, 9–140  
 STARTUP REMOVE command  
     in SYSMAN, *Vol 2: M-Z*, 9–142  
 STARTUP SET DATABASE command  
     in SYSMAN, *Vol 2: M-Z*, 9–143  
 STARTUP SET OPTIONS command  
     in SYSMAN, *Vol 2: M-Z*, 9–144  
 STARTUP SHOW command  
     in SYSMAN, *Vol 2: M-Z*, 9–146  
 STARTUP\_Pn system parameters, *Vol 2: M-Z*, D–64  
     in SYSMAN, *Vol 2: M-Z*, 9–135  
 STATES class record  
     in Monitor utility, *Vol 2: M-Z*, A–34  
 Static service rating, *Vol 1: A-L*, 14–15, 14–47  
     displaying, *Vol 1: A-L*, 14–58, 14–66  
 Statistical information  
     about volume under verification, *Vol 1: A-L*, 3–18  
 /STATISTICS qualifier  
     in Analyze/Disk\_Structure utility, *Vol 1: A-L*, 3–18  
 STATS.DAT file  
     created by ANALYZE/DISK\_STRUCTURE/STATISTICS, *Vol 1: A-L*, 3–18



## Subprocesses

See also SPAWN command

creating

from LATCP, *Vol 1: A-L*, 14–4, 14–68

with SPAWN command, *Vol 2: M-Z*, 9–131

with the LANCP SPAWN command, *Vol 1: A-L*, 13–51

switching control of input stream to, *Vol 2: M-Z*, 9–15

Subsystem ACEs, *Vol 1: A-L*, 1–14

example, *Vol 1: A-L*, 1–14

specifying identifier characteristics, *Vol 1: A-L*, 1–15

specifying identifiers, *Vol 1: A-L*, 1–14

Subsystem attribute, *Vol 1: A-L*, 5–19, 5–50, 5–72

Subsystems

controlling access to, *Vol 1: A-L*, 1–14

/SUMMARY qualifier

in Monitor utility, *Vol 2: M-Z*, 1–15

SWAPFILE.SYS file

See Swap files

Swap files

changing size, *Vol 1: A-L*, 6–1

displaying the size calculated by AUTOGEN, *Vol 1: A-L*, 6–7

generating a new file sized by AUTOGEN, *Vol 1: A-L*, 6–8

SWPFAIL system parameter, *Vol 2: M-Z*, D–65

SWPOUTPGCNT system parameter, *Vol 2: M-Z*, D–65

SWPRATE system parameter, *Vol 2: M-Z*, D–65

SWP\_PRIO system parameter, *Vol 2: M-Z*, D–64

Symbol table

command interpreter, *Vol 2: M-Z*, D–9

Syntax

of BACKUP commands, *Vol 1: A-L*, 7–3

YSALF.DAT database in SYSMAN, *Vol 2: M-Z*, 9–12

SYSBOOT facility

using during bootstrap operations, *Vol 2: M-Z*, 8–1

SYSDUMP.DMP file

See Dump files

SYSGEN

See System Generation utility (SYSGEN)

SYSLOST.DIR file, *Vol 1: A-L*, 3–3

SYSMAN

See System Management utility (SYSMAN)

SYSMANINI.INI file

changing file specification, *Vol 2: M-Z*, 9–2

SYSMWCNT system parameter, *Vol 2: M-Z*, D–65

SYSPFC system parameter, *Vol 2: M-Z*, D–65

SYSSER\_LOGGING system parameter, *Vol 2: M-Z*, D–65

SYSTEM class record

in Monitor utility, *Vol 2: M-Z*, A–36

System Dump Priority registry

adding records, *Vol 2: M-Z*, 9–55

description, *Vol 2: M-Z*, 9–55

displaying an in-memory copy of the file, *Vol 2: M-Z*, 9–65

interaction with BUGCHECK, *Vol 2: M-Z*, 9–55

listing records, *Vol 2: M-Z*, 9–58

loading contents of file into memory, *Vol 2: M-Z*, 9–59

modifying an entry in the file, *Vol 2: M-Z*, 9–60

removing an entry in the file, *Vol 2: M-Z*, 9–63

unloading an in-memory copy of the file, *Vol 2: M-Z*, 9–66

System Generation utility (SYSGEN)

assign parameter values, *Vol 2: M-Z*, 8–8

commands

CREATE, *Vol 2: M-Z*, 8–3

DEINSTALL, *Vol 2: M-Z*, 8–4

DISABLE, *Vol 2: M-Z*, 8–5

ENABLE, *Vol 2: M-Z*, 8–6

INSTALL, *Vol 2: M-Z*, 8–7

SET, *Vol 2: M-Z*, 8–8

SET/OUTPUT, *Vol 2: M-Z*, 8–9

SET/STARTUP, *Vol 2: M-Z*, 8–10

SHOW, *Vol 2: M-Z*, 8–11

SHOW/STARTUP, *Vol 2: M-Z*, 8–16

TERMINAL, *Vol 2: M-Z*, 8–17

USE, *Vol 2: M-Z*, 8–18

WRITE, *Vol 2: M-Z*, 8–20

directing output, *Vol 2: M-Z*, 8–1

parameters

See also System parameters

showing parameter values, *Vol 2: M-Z*, 8–11

specifying file output, *Vol 2: M-Z*, 8–9

work area, *Vol 2: M-Z*, 8–8, 8–18, 8–20

System loadable image

adding, *Vol 2: M-Z*, 9–148

removing, *Vol 2: M-Z*, 9–150

System management

clearing counters, *Vol 1: A-L*, 13–7

creating disk quota files, *Vol 2: M-Z*, 9–38

defining target system, *Vol 2: M-Z*, 9–119

deleting device information, *Vol 1: A-L*, 13–6, 13–21

deleting node information, *Vol 1: A-L*, 13–8, 13–22

displaying LAN device parameters, *Vol 1: A-L*, 13–17, 13–42

displaying node information, *Vol 1: A-L*, 13–19, 13–49

displaying OPCOM messages, *Vol 1: A-L*, 13–23

displaying status and counters, *Vol 1: A-L*, 13–19, 13–46, 13–49

displaying target environment, *Vol 2: M-Z*, 9–123

## System management (cont'd)

- displaying user profile, *Vol 2: M-Z*, 9–125
- displaying wait time for node response, *Vol 2: M-Z*, 9–126
- invoking the InfoServer utility, *Vol 1: A-L*, 11–2
- invoking the LANCP utility, *Vol 1: A-L*, 13–2
- LANCP SPAWN command, *Vol 1: A-L*, 13–51
- limiting response time, *Vol 2: M-Z*, 9–122
- MOP console carrier, *Vol 1: A-L*, 13–9
- MOP trigger boot, *Vol 1: A-L*, 13–52
- setting device information, *Vol 1: A-L*, 13–13
- setting wait time for node response, *Vol 2: M-Z*, 9–122
- startup procedures

See Startup database

- SYSMAN tasks, *Vol 2: M-Z*, 9–1

## System management environment

See Management environment

## System Management utility (SYSMAN)

### commands

- ALF ADD, *Vol 2: M-Z*, 9–10
- ALF REMOVE, *Vol 2: M-Z*, 9–12
- ALF SHOW, *Vol 2: M-Z*, 9–14
- ATTACH, *Vol 2: M-Z*, 9–15
- CLASS\_SCHEDULE, *Vol 2: M-Z*, 9–17
- CONFIGURATION SET CLUSTER\_AUTH, *Vol 2: M-Z*, 9–28
- CONFIGURATION SET TIME, *Vol 2: M-Z*, 9–30
- CONFIGURATION SHOW CLUSTER\_AUTHORIZATION, *Vol 2: M-Z*, 9–32
- CONFIGURATION SHOW TIME, *Vol 2: M-Z*, 9–33
- DEFINE/KEY, *Vol 2: M-Z*, 9–34
- DISKQUOTA ADD, *Vol 2: M-Z*, 9–36
- DISKQUOTA CREATE, *Vol 2: M-Z*, 9–38
- DISKQUOTA DELETE, *Vol 2: M-Z*, 9–40
- DISKQUOTA DISABLE, *Vol 2: M-Z*, 9–41
- DISKQUOTA ENABLE, *Vol 2: M-Z*, 9–43
- DISKQUOTA MODIFY, *Vol 2: M-Z*, 9–45
- DISKQUOTA REBUILD, *Vol 2: M-Z*, 9–47
- DISKQUOTA REMOVE, *Vol 2: M-Z*, 9–48
- DISKQUOTA SHOW, *Vol 2: M-Z*, 9–50
- DO, *Vol 2: M-Z*, 9–51
- DUMP\_PRIORITY ADD, *Vol 2: M-Z*, 9–55
- DUMP\_PRIORITY LIST, *Vol 2: M-Z*, 9–58
- DUMP\_PRIORITY LOAD, *Vol 2: M-Z*, 9–59
- DUMP\_PRIORITY MODIFY, *Vol 2: M-Z*, 9–60
- DUMP\_PRIORITY REMOVE, *Vol 2: M-Z*, 9–63
- DUMP\_PRIORITY SHOW, *Vol 2: M-Z*, 9–65
- DUMP\_PRIORITY UNLOAD, *Vol 2: M-Z*, 9–66

## System Management utility (SYSMAN)

### commands (cont'd)

- EXIT, *Vol 2: M-Z*, 9–67
- HELP, *Vol 2: M-Z*, 9–68
- IO AUTOCONFIGURE, *Vol 2: M-Z*, 9–69
- IO CONNECT, *Vol 2: M-Z*, 9–71
- IO CREATE\_WWID, *Vol 2: M-Z*, 9–75
- IO FIND\_WWID, *Vol 2: M-Z*, 9–76
- IO LIST\_WWID, *Vol 2: M-Z*, 9–79
- IO LOAD, *Vol 2: M-Z*, 9–80
- IO REBUILD, *Vol 2: M-Z*, 9–81
- IO REPLACE\_WWID, *Vol 2: M-Z*, 9–82
- IO SCSI\_PATH\_VERIFY, *Vol 2: M-Z*, 9–84
- IO SET EXCLUDE, *Vol 2: M-Z*, 9–85
- IO SET PREFIX, *Vol 2: M-Z*, 9–86
- IO SHOW BUS, *Vol 2: M-Z*, 9–87
- IO SHOW DEVICE, *Vol 2: M-Z*, 9–89
- IO SHOW EXCLUDE, *Vol 2: M-Z*, 9–91
- IO SHOW PREFIX, *Vol 2: M-Z*, 9–92
- LICENSE LOAD, *Vol 2: M-Z*, 9–93
- LICENSE UNLOAD, *Vol 2: M-Z*, 9–94
- PARAMETERS DISABLE CHECKS, *Vol 2: M-Z*, 9–95
- PARAMETERS ENABLE CHECKS, *Vol 2: M-Z*, 9–96
- PARAMETERS SET, *Vol 2: M-Z*, 9–97
- PARAMETERS SHOW, *Vol 2: M-Z*, 9–98
- PARAMETERS USE, *Vol 2: M-Z*, 9–103
- PARAMETERS WRITE, *Vol 2: M-Z*, 9–104
- RESERVED\_MEMORY ADD, *Vol 2: M-Z*, 9–105
- RESERVED\_MEMORY EXTEND, *Vol 2: M-Z*, 9–109
- RESERVED\_MEMORY FREE, *Vol 2: M-Z*, 9–110
- RESERVED\_MEMORY LIST, *Vol 2: M-Z*, 9–112
- RESERVED\_MEMORY MODIFY, *Vol 2: M-Z*, 9–113
- RESERVED\_MEMORY REMOVE, *Vol 2: M-Z*, 9–116
- RESERVED\_MEMORY SHOW, *Vol 2: M-Z*, 9–117
- SET ENVIRONMENT, *Vol 2: M-Z*, 9–119
- SET PROFILE, *Vol 2: M-Z*, 9–121
- SET TIMEOUT, *Vol 2: M-Z*, 9–122
- SHOW ENVIRONMENT, *Vol 2: M-Z*, 9–123
- SHOW KEY, *Vol 2: M-Z*, 9–124
- SHOW PROFILE, *Vol 2: M-Z*, 9–125
- SHOW TIMEOUT, *Vol 2: M-Z*, 9–126
- SHUTDOWN NODE, *Vol 2: M-Z*, 9–127
- SPAWN, *Vol 2: M-Z*, 9–131
- STARTUP ADD, *Vol 2: M-Z*, 9–135
- STARTUP DISABLE, *Vol 2: M-Z*, 9–137
- STARTUP ENABLE, *Vol 2: M-Z*, 9–139
- STARTUP MODIFY, *Vol 2: M-Z*, 9–140
- STARTUP REMOVE, *Vol 2: M-Z*, 9–142

## System Management utility (SYSMAN)

### commands (cont'd)

- STARTUP SET DATABASE, *Vol 2: M-Z*, 9-143
- STARTUP SET OPTIONS, *Vol 2: M-Z*, 9-144
- STARTUP SHOW, *Vol 2: M-Z*, 9-146
- SYS\_LOADABLE ADD, *Vol 2: M-Z*, 9-148
- SYS\_LOADABLE REMOVE, *Vol 2: M-Z*, 9-150

common tasks, *Vol 2: M-Z*, 9-1

executing a command procedure, *Vol 2: M-Z*, 9-8

executing SYSMAN commands, *Vol 2: M-Z*, 9-2

exiting from, *Vol 2: M-Z*, 9-3

initialization file, *Vol 2: M-Z*, 9-2

invoking, *Vol 2: M-Z*, 9-3

overview, *Vol 2: M-Z*, 9-1

privilege requirements, *Vol 2: M-Z*, 9-3

restrictions, *Vol 2: M-Z*, 9-3

rights identifiers, *Vol 2: M-Z*, 9-3

### System overview statistics

in Monitor utility, *Vol 2: M-Z*, 1-70

### System parameters

See also AUTOGEN.COM command procedure ACP, *Vol 2: M-Z*, D-3 to D-7

affected by AUTOGEN feedback, *Vol 1: A-L*, 6-6

categories, *Vol 2: M-Z*, D-1

#### changing

recommended method, *Vol 1: A-L*, 6-1

changing during installation, *Vol 1: A-L*, 6-2

checking, *Vol 2: M-Z*, 9-96

checking AUTOGEN's settings, *Vol 1: A-L*, 6-5

default parameter file, *Vol 1: A-L*, 6-6, 6-8

disabling checking, *Vol 2: M-Z*, 9-95

displaying, *Vol 2: M-Z*, 9-98

parameter values, *Vol 2: M-Z*, 8-11

startup procedure, *Vol 2: M-Z*, 8-16

values, *Vol 2: M-Z*, 8-11

#### file

See Parameter files

modifying, *Vol 2: M-Z*, 9-104

recommended method, *Vol 1: A-L*, 6-1

setting, *Vol 2: M-Z*, 9-97

parameter addresses, *Vol 2: M-Z*, 8-8

parameter values, *Vol 2: M-Z*, 8-1, 8-8, 8-11, 8-18, 8-20

recommended method, *Vol 1: A-L*, 6-1

showing, *Vol 2: M-Z*, 8-11

specifying startup procedure, *Vol 2: M-Z*, 8-10, 8-18, 8-20

terminal behavior, *Vol 2: M-Z*, D-68 to D-73

VIRTUALPAGECNT, *Vol 1: A-L*, 3-1

VMS, *Vol 2: M-Z*, D-77

work area, *Vol 2: M-Z*, 9-103, 9-104

writing contents of, *Vol 2: M-Z*, 9-104

## System parameters (cont'd)

writing to file, *Vol 2: M-Z*, 8-20

System passwords, *Vol 1: A-L*, 5-76

### SYSTEMS class

adding or restoring, *Vol 2: M-Z*, 7-36

fields belonging to, *Vol 2: M-Z*, 7-9

removing, *Vol 2: M-Z*, 7-60

### Systems Communications Services

See SCS

### System shutdown

to install changed system parameters, *Vol 1: A-L*, 6-8

### System time

setting, *Vol 2: M-Z*, 9-30

SYSTEM\_CHECK system parameter, *Vol 2: M-Z*, D-65

### SYSUAF logical name

defining, *Vol 1: A-L*, 5-1

### SYSUAFs (system user authorization files)

creating, *Vol 1: A-L*, 5-1

default directory entry, *Vol 1: A-L*, 5-17

default values, *Vol 1: A-L*, 5-17

displaying records in, *Vol 1: A-L*, 5-85

modifying, *Vol 1: A-L*, 5-1

recreating, *Vol 1: A-L*, 5-2

renaming records, *Vol 1: A-L*, 5-80

### SYS\_LOADABLE ADD command

in SYSMAN, *Vol 2: M-Z*, 9-148

### SYS\_LOADABLE REMOVE command

in SYSMAN, *Vol 2: M-Z*, 9-150

## T

### Tape drive

using /MEDIA\_FORMAT qualifier, *Vol 1: A-L*, 7-72

TAPE\_ALLOCLASS system parameter, *Vol 2: M-Z*, D-66

### /TAPE\_EXPIRATION qualifier

in Backup utility, *Vol 1: A-L*, 7-96

TAPE\_MVTIMEOUT system parameter, *Vol 2: M-Z*, D-66

Target node name, *Vol 1: A-L*, 14-62

Target port name, *Vol 1: A-L*, 14-62

Target service name, *Vol 1: A-L*, 14-62

TBSKIPWSL system parameter, *Vol 2: M-Z*, D-66

### Telnet protocol

Break-in evasion, *Vol 2: M-Z*, D-25

### TERMINAL command

in SYSGEN, *Vol 2: M-Z*, 8-17

### Terminals

modifying control-key echo strings, *Vol 2: M-Z*, 8-17

sending alarm messages to, *Vol 1: A-L*, 1-4

Terminating a session, *Vol 1: A-L*, 3-6

TESTFILES phase of AUTOGEN, *Vol 1: A-L*, 6-7

## Time

See also SYSMAN command CONFIGURATION SHOW TIME

### cluster

- displaying, *Vol 2: M-Z*, 9–33
- extracting records by, *Vol 1: A-L*, 4–4
- setting system, *Vol 2: M-Z*, 9–30
- updating in a cluster, *Vol 2: M-Z*, 9–31

### Timeout period

- displaying, *Vol 2: M-Z*, 9–126
- setting, *Vol 2: M-Z*, 9–122

TIMEPROMPTWAIT system parameter, *Vol 2: M-Z*, D–67

### TIMER class record

- in Monitor utility, *Vol 2: M-Z*, A–37

### Timer queue entries (TQEs)

- monitoring, *Vol 2: M-Z*, A–37

### Timer Queue Entry (TQE) statistics

- in Monitor utility, *Vol 2: M-Z*, 1–74

### Timers

- for circuits, *Vol 1: A-L*, 14–32
- for multicast message in LAT environment, *Vol 1: A-L*, 14–36
- setting in a LAT environment, *Vol 1: A-L*, 14–35

TIME\_CONTROL system parameter, *Vol 2: M-Z*, D–66

TIMVCFAIL system parameter, *Vol 2: M-Z*, D–67

TMSCP\_LOAD system parameter, *Vol 2: M-Z*, D–67

TMSCP\_SERVE\_ALL system parameter, *Vol 2: M-Z*, D–68

### TRANSACTION class record

- in Monitor utility, *Vol 2: M-Z*, A–38

### Transaction logs

- used by DECdtm, *Vol 1: A-L*, 15–1

### Transactions

- monitoring, *Vol 2: M-Z*, 1–76

### TRANSLATE command

- in Install utility, *Vol 1: A-L*, 12–2

### Trigger boot

- LANCP MOP downline load service, *Vol 1: A-L*, 13–52

### TRIGGER NODE command

- in LANCP utility, *Vol 1: A-L*, 13–52

### TR numbers

- display on Alpha and Integrity servers, *Vol 2: M-Z*, 9–87

### /TRUNCATE qualifier

- in Backup utility, *Vol 1: A-L*, 7–97

### TTY system parameters

See also System parameters

#### terminal behavior

- TTY\_ALTALARM, *Vol 2: M-Z*, D–68
- TTY\_ALTYPAHD, *Vol 2: M-Z*, D–69
- TTY\_AUTOCHAR, *Vol 2: M-Z*, D–69
- TTY\_BUF, *Vol 2: M-Z*, D–69

### TTY system parameters (cont'd)

- TTY\_CLASSNAME, *Vol 2: M-Z*, D–69
- TTY\_DEFCHAR, *Vol 2: M-Z*, D–69
- TTY\_DEFCHAR2, *Vol 2: M-Z*, D–70
- TTY\_DEFCHAR3, *Vol 2: M-Z*, D–71
- TTY\_DEFPORT, *Vol 2: M-Z*, D–71
- TTY\_DIALTYPE, *Vol 2: M-Z*, D–71
- TTY\_DMASIZE, *Vol 2: M-Z*, D–71
- TTY\_PARITY, *Vol 2: M-Z*, D–72
- TTY\_RSPEED, *Vol 2: M-Z*, D–72
- TTY\_SCANDELTA, *Vol 2: M-Z*, D–72
- TTY\_SILOTIME, *Vol 2: M-Z*, D–72
- TTY\_SPEED, *Vol 2: M-Z*, D–72
- TTY\_TIMEOUT, *Vol 2: M-Z*, D–72
- TTY\_TYPAHDSZ, *Vol 2: M-Z*, D–73

## U

UAFALTERNATE system parameter, *Vol 2: M-Z*, D–73

### UAFs (user authorization files)

See SYSUAFs

### UCM

See USB Configuration Manager

### UIC-based protection

See Protection codes

### UICs (user identification codes)

- for disk quota file, *Vol 2: M-Z*, 9–36
- identifiers, *Vol 1: A-L*, 1–12

Unloading licenses, *Vol 2: M-Z*, 9–94

### UPDATE DEVICE command

- in LANCP utility, *Vol 1: A-L*, 13–53

### Usage count

- updating, *Vol 2: M-Z*, 9–47

/USAGE qualifier, *Vol 1: A-L*, 3–4, 3–20

- in Analyze/Disk\_Structure utility, *Vol 1: A-L*, 3–20

### USB Configuration Manager (UCM)

- description, *Vol 2: M-Z*, 10–1

### USB Configuration Manager (UCM) utility

ADD DEVICE command, *Vol 2: M-Z*, 10–14

DELETE DEVICE command, *Vol 2: M-Z*, 10–16

EXIT command, *Vol 2: M-Z*, 10–17

HELP command, *Vol 2: M-Z*, 10–18

MODIFY DEVICE command, *Vol 2: M-Z*, 10–19

RELOAD command, *Vol 2: M-Z*, 10–21

RESTART command, *Vol 2: M-Z*, 10–22

SET AUTO command, *Vol 2: M-Z*, 10–23

SET LOG command, *Vol 2: M-Z*, 10–25

SHOW AUTO command, *Vol 2: M-Z*, 10–26

SHOW DEVICE command, *Vol 2: M-Z*, 10–27

### USE command

- in SYSGEN, *Vol 2: M-Z*, 8–18



User (security category)  
controlling types of access, *Vol 1: A-L*, 1–12

User accounts  
altering, *Vol 1: A-L*, 5–60  
creating, *Vol 1: A-L*, 5–6  
deleting, *Vol 1: A-L*, 5–77

User directories  
creating for a new account, *Vol 1: A-L*, 5–18

User identification codes  
See UICs

User names  
as identifiers, *Vol 1: A-L*, 1–12  
identifiers added with, *Vol 1: A-L*, 5–18  
specifying with wildcards, *Vol 1: A-L*, 5–3

USER system parameters  
USER3, *Vol 2: M-Z*, D–73  
USER4, *Vol 2: M-Z*, D–73  
USERD1, *Vol 2: M-Z*, D–73  
USERD2, *Vol 2: M-Z*, D–73

## V

VAXCLUSTER system parameter, *Vol 2: M-Z*, D–73

VAXVMSSYS.OLD file, *Vol 1: A-L*, 6–8

VAXVMSSYS.PAR file, *Vol 1: A-L*, 6–8

VCC\_FLAGS system parameter, *Vol 2: M-Z*, D–74

VCC\_MAXSIZE system parameter, *Vol 2: M-Z*, D–74

VCC\_MAX\_CACHE system parameter, *Vol 2: M-Z*, D–74

VCC\_MAX\_IO\_SIZE system parameter, *Vol 2: M-Z*, D–75

VCC\_MAX\_LOCKS system parameter, *Vol 2: M-Z*, D–75

VCC\_PAGESIZE system parameter, *Vol 2: M-Z*, D–75

VCC\_READAHEAD system parameter, *Vol 2: M-Z*, D–75

VCC\_RSVD system parameter, *Vol 2: M-Z*, D–76

VCC\_WRITEBEHIND system parameter, *Vol 2: M-Z*, D–76

VCC\_WRITE\_DELAY system parameter, *Vol 2: M-Z*, D–76

Vector processing  
monitoring, *Vol 2: M-Z*, 1–79

Verification  
of disk volumes, *Vol 1: A-L*, 3–1

/VERIFY qualifier  
in Backup utility, *Vol 1: A-L*, 7–98

VHPT\_SIZE system parameter, *Vol 2: M-Z*, D–76

/VIEWING\_TIME qualifier  
in Monitor utility, *Vol 2: M-Z*, 1–16

Virtual memory  
requirements for bitmaps, *Vol 1: A-L*, 3–1

VIRTUALPAGECNT system parameter, *Vol 1: A-L*, 3–1; *Vol 2: M-Z*, D–76

VMS\$RESERVED\_MEMORY.DATA  
Reserved Memory Registry file, *Vol 2: M-Z*, 9–107

VMS\$SYSTEM\_IMAGES.IDX  
adding an entry, *Vol 2: M-Z*, 9–149  
removing an entry, *Vol 2: M-Z*, 9–150

VMS\$VAXcluster  
communications  
receiving, *Vol 2: M-Z*, D–9

VMSIMAGES.DAT file, *Vol 1: A-L*, 6–7

VMS system parameters  
See System parameters

VMS\_BCFG utility, *Vol 1: A-L*, 9–4

VMS\_SET utility, *Vol 1: A-L*, 9–6

VMS\_SHOW utility, *Vol 1: A-L*, 9–7

/VOLUME qualifier  
in Backup utility, *Vol 1: A-L*, 7–99

Volume quota file  
See Disk quotas

Volumes  
repairing errors on a disk volume, *Vol 1: A-L*, 3–15

Volume sets  
image save operation, *Vol 1: A-L*, 7–54

VOTES system parameter, *Vol 2: M-Z*, D–77

## W

WBM\_MSG\_INT system parameter, *Vol 2: M-Z*, D–77

WBM\_MSG\_LOWER system parameter, *Vol 2: M-Z*, D–77

WBM\_MSG\_UPPER system parameter, *Vol 2: M-Z*, D–78

WBM\_OPCOM\_LVL system parameter, *Vol 2: M-Z*, D–78

Wildcard characters, *Vol 1: A-L*, 7–5  
restriction in ACL editor, *Vol 1: A-L*, 1–2  
using to represent directories, *Vol 1: A-L*, 7–5

/WINDOW qualifier  
in Backup utility, *Vol 1: A-L*, 7–103

Windows  
compressing or expanding, *Vol 2: M-Z*, 7–71  
designating, *Vol 2: M-Z*, 7–66  
display SHOW CLUSTER information, *Vol 2: M-Z*, 7–10  
moving, *Vol 2: M-Z*, 7–67  
rearranging, *Vol 2: M-Z*, 7–45  
scrolling, *Vol 2: M-Z*, 7–64  
terminating selection, *Vol 2: M-Z*, 7–41  
viewing large display, *Vol 2: M-Z*, 7–47

WINDOW\_SYSTEM system parameter, *Vol 2: M-Z*, D–78

WLKSYSDSK system parameter, *Vol 2: M-Z*,  
D-78  
Work area  
  copying to parameter file, *Vol 2: M-Z*, 9-104  
  loading parameters, *Vol 2: M-Z*, 9-103  
WPRE\_SIZE system parameter, *Vol 2: M-Z*, D-78  
WPTTE\_SIZE system parameter, *Vol 2: M-Z*,  
D-79  
WRITABLESYS system parameter, *Vol 2: M-Z*,  
D-79  
WRITE command  
  in Show Cluster utility, *Vol 2: M-Z*, 7-72  
  in SYSGEN, *Vol 2: M-Z*, 8-20  
WRITESYSPARAMS system parameter, *Vol 2:*  
*M-Z*, D-79  
WSDEC system parameter, *Vol 2: M-Z*, D-79  
WSINC system parameter, *Vol 2: M-Z*, D-79  
WSMAX system parameter, *Vol 2: M-Z*, D-79

## X

---

XA Gateway Control Program (XGCP)  
  commands  
    CREATE\_LOG, *Vol 2: M-Z*, 11-2  
    EXIT, *Vol 2: M-Z*, 11-3  
    START\_SERVER, *Vol 2: M-Z*, 11-4  
    STOP\_SERVER, *Vol 2: M-Z*, 11-5  
  invoking, *Vol 2: M-Z*, 11-1  
  overview, *Vol 2: M-Z*, 11-1  
XGCP  
  See XA Gateway Control Program (XGCP)  
XQPCTL2 system parameter, *Vol 2: M-Z*, D-80  
XQPCTLD1 system parameter, *Vol 2: M-Z*, D-80

## Z

---

ZERO COUNTERS command  
  in LATCP, *Vol 1: A-L*, 14-69  
ZERO\_LIST\_HI system parameter, *Vol 2: M-Z*,  
D-80