

DECnet-Plus

Problem Solving

Order Number: AA-Q18ZE-TE

November 1996

This manual describes using DECnet-Plus tools to isolate and correct simple DECnet-Plus problems in the OpenVMS and Digital UNIX environments.

Revision/Update Information:	This is a revised manual.
Operating Systems:	OpenVMS VAX Version 7.1 OpenVMS Alpha Version 7.1 Digital UNIX Version 4.0
Software Versions:	DECnet-Plus for OpenVMS Version 7.1 DECnet/OSI for Digital UNIX Version 4.0

Digital Equipment Corporation
Maynard, Massachusetts

November 1996

Digital Equipment Corporation makes no representations that the use of its products in the manner described in this publication will not infringe on existing or future patent rights, nor do the descriptions contained in this publication imply the granting of licenses to make, use, or sell equipment or software in accordance with the description.

Possession, use, or copying of the software described in this publication is authorized only pursuant to a valid written license from Digital or an authorized sublicensor.

Digital conducts its business in a manner that conserves the environment and protects the safety and health of its employees, customers, and the community.

© Digital Equipment Corporation 1996. All rights reserved.

The following are trademarks of Digital Equipment Corporation: Bookreader, DDCMP, DEC, DECdirect, DECnet, DECNIS, DECserver, DECsystem, DECwindows, Digital, DNA, InfoServer, OpenVMS, PATHWORKS, ULTRIX, VAX, VAX DOCUMENT, VAXcluster, VAXstation, VMS, VMScluster, and the DIGITAL logo.

The following are third-party trademarks:

Macintosh is a registered trademark of Apple Computer, Inc.

MS-DOS is a registered trademark of Microsoft Corporation.

OS/2 is a registered trademark of International Business Machines Corporation.

OSF/1 is a registered trademark of Open Software Foundation, Inc.

SCO is a trademark of Santa Cruz Operations, Inc.

UNIX is a registered trademark in the United States and other countries, licensed exclusively through X/Open Co. Ltd.

All other trademarks and registered trademarks are the property of their respective holders.

Contents

Preface	ix
1 Fault-Isolation Overview	
1.1 Understanding the DECnet-Plus Network Model	1-2
1.1.1 OSI Network Layer Functions	1-2
1.1.2 DNA Layer Functions	1-3
1.1.3 TCP/IP Interoperability	1-3
1.2 Classifying Problems	1-4
1.2.1 Reproducible Problems	1-4
1.2.2 Intermittent Problems	1-4
1.2.3 Transient Problems	1-4
1.3 DECnet-Plus Component Relationships	1-4
1.3.1 Component Relationships (OpenVMS Only)	1-4
1.3.2 Component Relationships (Digital UNIX Only)	1-6
1.4 Methods for Isolating Faults	1-8
1.4.1 Questions to Ask Yourself	1-8
1.4.2 Fault Isolation in the DECnet-Plus Environment	1-8
1.4.3 DECnet-Plus Fault-Isolation Methodology	1-8
1.4.4 Isolating Faults for Reproducible Problems	1-10
1.4.5 Isolating Faults for Intermittent or Transient Problems	1-10
1.4.6 Documenting the Fault-Isolation Process and Problem Solution	1-10
2 Preparing for Problem Solving	
2.1 DECnet-Plus Symptom Table	2-2
2.2 Types of Problem-Solving Information	2-3
2.2.1 Definitions	2-3
2.2.2 Tools and Commands to Use	2-3
2.3 Understanding Your Network Topology	2-5
2.3.1 The decnet_migrate Tool	2-5
2.3.2 When to Use the decnet_migrate Tool	2-5
2.3.3 References	2-5
2.4 Recognizing Node Names and Synonyms	2-6
2.4.1 Identifying Node Names	2-6
2.4.2 Finding Node Names and Node Synonyms	2-6
2.5 Finding the Operating System and Version	2-6
2.6 Getting DECnet-Plus Circuit Information	2-7
2.6.1 Routing DECnet-Plus Circuit Information for Problem Solving	2-7
2.6.2 Finding Routing Circuit Names, Types, States, and Adjacencies	2-7
2.6.3 Considerations for Broadcast Circuit Adjacencies	2-7
2.7 Preparing to Find a Network Path	2-8
2.7.1 Types of Network Information to Find	2-8
2.7.2 Finding Node Addresses for Node Names	2-9

2.7.3	Determining Network Entity Titles for DECnet-Plus Nodes	2-9
2.7.4	Converting Phase IV Addresses to NSAPs	2-9
2.7.5	Converting NSAP Addresses to Phase IV Format	2-10
2.8	Tracing DECnet-Plus Network Paths	2-10
2.8.1	Tracing the Network Path of DECnet-Plus Nodes	2-10
2.8.2	Tracing a Network Path in a Mixed Environment	2-12
2.8.3	X.25 DA Circuit Considerations	2-12
2.8.4	NCL Takes Long Time While Translating Addresses to Names	2-13

3 Testing Network Reachability

3.1	Types of Network Reachability Tests	3-2
3.1.1	Types of Loopback Tests	3-2
3.1.2	Using Loopback Tests on Phase IV Nodes	3-3
3.1.3	Types of dts/dtr Tests	3-3
3.2	OSI Echo Function Overview (Digital UNIX Only)	3-3
3.2.1	OSI ping Command Syntax	3-3
3.2.2	Restrictions	3-4
3.3	Node-Level Loopback Tests Overview	3-4
3.3.1	When to Use Node-Level Loopback Tests	3-4
3.3.2	Analyzing Local-to-Local Node Loopback Test Results	3-4
3.3.3	Log File for Local-to-Local Node Loopback Tests	3-5
3.3.4	Local-to-Local Node Loopback Figure	3-5
3.3.5	Analyzing Local-to-Remote Node Loopback Test Results	3-5
3.3.6	Local-to-Remote Loopback Test Figure	3-6
3.4	Running Node-Level Loopback Tests	3-6
3.4.1	Node-Level Loopback Command Parameters	3-6
3.4.2	Example of Node-Level Loopback Test	3-7
3.5	Circuit-Level Loopback Test Overview	3-7
3.5.1	Circuit-Level Loopback Test Figure	3-7
3.5.2	Identifying Node Addresses for Circuit-Level Loopback Tests	3-8
3.6	Preparing for Circuit-Level Loopback Tests	3-8
3.6.1	Example of Circuit-Level Loopback Preparation	3-9
3.7	Running Circuit-Level Loopback Tests	3-10
3.7.1	Circuit-Level Loopback Command Parameters	3-10
3.7.2	Example of Circuit-Level Loopback Test	3-11
3.8	Running Circuit-Level Loopback Tests with Assistance	3-11
3.8.1	When to Use Assistance	3-11
3.8.2	Using Assistance for Fault Isolation	3-11
3.8.3	Starting a Circuit-Level Loopback Test with Assistance	3-11
3.8.4	Assistance Parameters	3-12
3.8.5	Example of Circuit-Level Loopback Test with Full Assistance	3-12
3.8.6	Example of Circuit-Level Loopback Test with Transmit Assistance	3-13
3.8.7	Example of Circuit-Level Loopback Test with Receive Assistance	3-13
3.9	Running LAN Loopback Tests with LLC Messages	3-14
3.9.1	Starting the LAN Loopback Test	3-14
3.9.2	LAN Loopback Test Command Parameters	3-14
3.9.3	Determining Logical Link Control Types on a Remote Node	3-15
3.10	Running dts/dtr Tests	3-15
3.10.1	Starting dts/dtr Tests	3-15
3.10.2	dts Command Syntax	3-16
3.10.3	General Command Syntax Conventions	3-17
3.10.4	Examples of Using dts/dtr Test Command Procedures	3-17
3.11	Running dts/dtr Connect Tests	3-18

3.11.1	dts/dtr Connect Test Command Syntax	3-18
3.11.2	Example of dts/dtr Connect Test Command	3-19
3.12	Running dts/dtr Data Tests	3-19
3.12.1	dts/dtr Data Test Command Syntax	3-19
3.12.2	Example of dts/dtr Data Test Command	3-20
3.13	Running dts/dtr Disconnect Tests	3-21
3.13.1	dts/dtr Disconnect Test Command Syntax	3-21
3.13.2	Example of dts/dtr Disconnect Test Command	3-22
3.14	Running dts/dtr Interrupt Tests	3-22
3.14.1	Interrupt Test Command Syntax	3-22
3.14.2	Example of dts/dtr Interrupt Test Command	3-23

4 Solving Problems Using DECnet Over TCP/IP

4.1	Local IP Address Displays As 0.0.0.0	4-2
4.2	Troubleshooting	4-2

5 Solving DECnet-Plus Application Problems

5.1	Underlying Components for DECnet-Plus Applications (OpenVMS Only)	5-2
5.2	Underlying Components for DECnet/OSI Applications Digital UNIX Only	5-4
5.3	Symptoms of DECnet-Plus Application Problems	5-6
5.3.1	Problem Symptoms for All Systems	5-6
5.3.2	Problem Symptoms for OpenVMS Systems Only	5-7
5.3.3	Problem Symptoms for Digital UNIX Systems Only	5-7
5.4	Isolating DECnet-Plus Application Faults	5-8
5.4.1	Tools to Use	5-8
5.4.2	References	5-8
5.5	Using Event Logging and Log Files	5-9
5.5.1	Enabling Network Event Logging (OpenVMS Only)	5-9
5.5.2	Using the FTAM Responder Log File (OpenVMS Only)	5-9
5.6	Isolating Faults Using Management Tools (OpenVMS Only)	5-10
5.7	Tracing Overview	5-11
5.7.1	Trace Files	5-11
5.7.2	Security Information in Tracing	5-11
5.8	Tracing Outbound FTAM and Virtual Terminal Connections	5-11
5.8.1	Generating a Readable Trace File	5-12
5.8.2	ositrace Command Options (Digital UNIX Only)	5-12
5.9	Tracing Inbound FTAM and Virtual Terminal Connections	5-13
5.9.1	Inbound FTAM and VT Tracing (Digital UNIX)	5-13
5.9.2	Inbound FTAM Tracing (OpenVMS)	5-13
5.9.3	Inbound VT Tracing (OpenVMS)	5-14
5.10	Reading Trace Files	5-14
5.10.1	Interpreting Trace Information	5-15
5.11	Correcting FTAM Application Problems	5-16
5.12	Correcting FTAM File-Handling Problems	5-17
5.12.1	Checking Foreign Filename Formats	5-17
5.12.2	Correcting File Problems	5-17
5.13	Correcting General FTAM Connection Problems	5-18
5.14	Correcting FTAM and Virtual Terminal Connection Problems (Digital UNIX Only)	5-19
5.14.1	Address in Use	5-19

5.14.2	Network Is Unreachable	5-20
5.14.3	Connection Refused	5-20
5.14.4	Connection Timed Out	5-20
5.15	Correcting FTAM and Virtual Terminal Responder Problems (OpenVMS Only)	5-20
5.15.1	Correcting Unexpected Termination Problems	5-20
5.15.2	Correcting Responder Starting Problems	5-20
5.16	Correcting FTAM and Virtual Terminal Responder Problems (Digital UNIX Only)	5-21
5.17	Correcting FTAM Environment Problems (OpenVMS Only)	5-21
5.18	Correcting Target SAP Connection Problems	5-22
5.18.1	Correcting FTAM Physical and Data Link Problems	5-22
5.18.2	Correcting Network Connection Problems	5-22
5.18.3	Correcting FTAM and VT Transport Problems	5-25
5.18.4	Correcting FTAM and VT Session Problems (OpenVMS Only)	5-25
5.18.5	Correcting FTAM and VT Presentation Problems (OpenVMS Only)	5-26
5.19	Correcting Problems with Applications Using OSAK	5-26
5.19.1	Correcting Connection Problems	5-26
5.19.2	Correcting Unexpected Termination Problems	5-27
5.19.3	Correcting Programming Problems	5-27

6 Solving Session Control Problems

6.1	Underlying Components for Session Control (OpenVMS Only)	6-2
6.2	Underlying Components for Session Control (Digital UNIX Only)	6-4
6.2.1	References	6-5
6.3	Symptoms of Session Control Problems	6-6
6.4	Isolating Session Control Faults	6-7
6.4.1	Tools and Commands to Use	6-7
6.4.2	Fault-Isolation Methodology	6-8
6.5	Correcting Unknown Application Problems	6-10
6.6	Correcting Application Too Busy Problems	6-11
6.7	Correcting Access Control Problems	6-12
6.7.1	Correcting Proxy Access Problems (OpenVMS Only)	6-12
6.7.2	Correcting Proxy Access Problems (Digital UNIX Only)	6-13
6.7.3	Correcting Node Name Validation Problems	6-14
6.8	Correcting Insufficient Resource Problems	6-14
6.9	Correcting Timed Out Problems	6-15
6.10	Correcting Node Name Resolution Problems	6-15
6.10.1	Monitoring Search Path Processing (OpenVMS Only)	6-15
6.10.2	Tracing Node Name Resolution Problems (Digital UNIX Only)	6-16
6.10.3	Displaying Search Path Information	6-16
6.10.4	Identifying Namespace Consistency Problems	6-16
6.11	Examining the DECnet-Plus Naming Cache (OpenVMS Only)	6-17
6.11.1	Managing the Naming Cache	6-17
6.11.2	Dumping the Naming Cache	6-17

7 Solving Transport Problems

7.1	Underlying Components (OpenVMS Only)	7-2
7.2	Underlying Components (Digital UNIX Only)	7-4
7.3	Symptoms of Transport Problems	7-6
7.4	Isolating Transport Layer Problems	7-6
7.4.1	Tools to Use	7-6
7.4.2	Fault-Isolation Methodology	7-7
7.5	Correcting Connection Problems	7-8
7.5.1	Checking Ports	7-8
7.5.2	Checking NSAP Counters	7-9
7.6	Correcting OSI Transport Over CLNS Connection Problems	7-11
7.7	Correcting OSI Transport Over CONS (X.25) Connection Problems	7-12
7.8	Troubleshooting RFC 1006	7-13
7.8.1	Common Problems	7-13

8 Solving Network Layer Problems

8.1	Underlying Entities (OpenVMS Only)	8-2
8.2	Underlying Entities (Digital UNIX Only)	8-4
8.3	Symptoms of Network Layer Problems	8-6
8.4	Isolating Network Layer Problems	8-6
8.4.1	Tools to Use	8-6
8.4.2	Fault-Isolation Methodology	8-7
8.5	Finding Underlying Entities	8-8
8.5.1	Finding the Underlying Entities for HDLC Circuits	8-8
8.5.2	Finding the HDLC Circuits for a Physical Device	8-8
8.5.3	Finding the Underlying Entities for DDCMP Circuits (OpenVMS Only)	8-9
8.5.4	Finding the DDCMP Circuits for a Physical Device (OpenVMS Only)	8-9
8.5.5	Finding the Underlying Entities for CSMA-CD Circuits	8-9
8.5.6	Finding the CSMA-CD Circuit for a Physical Device	8-10
8.5.7	Finding the Underlying Entities for FDDI Circuits	8-10
8.5.8	Finding the FDDI Circuit for a Physical Device	8-10
8.5.9	Finding the Underlying Entities for Token Ring Circuits (Digital UNIX Only)	8-11
8.5.10	Finding the Token Ring Circuit for a Physical Device (Digital UNIX Only)	8-11
8.6	Correcting Configuration Problems	8-11
8.6.1	Correcting DDCMP (OpenVMS Only) and HDLC Data Link Configuration Problems	8-11
8.6.2	Correcting CSMA-CD Data Link Configuration Problems	8-12
8.7	Correcting Connectivity Problems	8-12

A Using the OSAKtrace Utility

B DECnet-Plus Application Tracing Examples

B.1	DECnet-Plus Application Trace Example	B-2
B.1.1	Association Establishment — Initiator	B-2
B.1.2	Association Establishment — Responder	B-6
B.1.3	Passing User Data — Responder	B-11

Index

Figures

1-1	DECnet-Plus Network Model	1-2
1-2	Component Relationships (OpenVMS)	1-5
1-3	Component Relationships (Digital UNIX)	1-7
1-4	Fault-Isolation Methodology (General)	1-9
3-1	Local-to-Local Loopback Test	3-5
3-2	Local-to-Remote Loopback Test	3-6
3-3	Circuit-Level Loopback Test	3-8
3-4	Circuit-Level Loopback Test with Full Assistance	3-13
3-5	Circuit-Level Loopback Test with Transmit Assistance	3-13
3-6	Circuit-Level Loopback Test with Receive Assistance	3-14
5-1	Underlying DECnet-Plus Components (OpenVMS)	5-3
5-2	Underlying DECnet/OSI Components (Digital UNIX)	5-5
6-1	Underlying Components for Session Control (OpenVMS)	6-3
6-2	Underlying Components for Session Control (Digital UNIX)	6-5
6-3	Fault-Isolation Methodology (Session Control)	6-9
7-1	Underlying Components (OpenVMS)	7-3
7-2	Underlying Components (Digital UNIX)	7-5
7-3	Fault-Isolation Methodology (Transport)	7-7
8-1	Underlying Entities (OpenVMS)	8-3
8-2	Underlying Entities (Digital UNIX)	8-5
8-3	Fault-Isolation Methodology (Circuit Connectivity)	8-7

Tables

1-1	OSI Network Layers	1-2
1-2	DNA Network Layers	1-3
2-1	DECnet-Plus Symptom Table	2-2
2-2	Problem Solving Tools and Commands	2-4
2-3	Phase IV and DECnet-Plus Node Name Differences	2-6
2-4	Types of Network Information to Trace	2-8
5-1	Symptoms and Problems for All Systems	5-6
5-2	Symptoms and Problems for OpenVMS	5-7
5-3	Symptoms and Problems for Digital UNIX	5-7
5-4	Tools for Isolating Application Faults	5-8
5-5	ositrace Command Options	5-12
6-1	Symptoms of Session Control Problems	6-6
8-1	Symptoms of Network Layer Problems	8-6

Preface

DECnet-Plus Problem Solving describes how to use DECnet-Plus tools to isolate and correct simple DECnet-Plus problems in the OpenVMS and Digital UNIX environments.

Intended Audience

DECnet-Plus Problem Solving is for network managers and system managers who work in a DECnet-Plus environment.

Assumed knowledge

Readers of this book are expected to have a basic understanding of DECnet and OSI networking concepts. It is assumed that readers have experience with DECnet-Plus network management tools such as the Network Control Language (NCL), and DECnet Phase IV tools, such as the Network Control Program (NCP).

Related Documents

- DECnet Phase IV management documentation
- Phase IV network troubleshooting documentation
- DECnet-Plus network management documentation
- DECnet-Plus NCL reference documentation
- OSI Applications Kernel (OSAK) documentation
- DECdns or other name service documentation
- DECdts documentation
- The *Common Trace Facility Use* manual
- X.25 problem-solving documentation
- FTAM and Virtual Terminal documentation

Reader's Comments

Digital welcomes your comments on this manual or any of the DECnet-Plus documents. Send us your comments through any of the following channels:

Internet	openvmsdoc@zko.mts.dec.com
Fax	603 881-0120, Attention: OSSG Documentation, ZKO3-4/U08
Mail	OSSG Documentation Group, ZKO3-4/U08 110 Spit Brook Rd. Nashua, NH 03062-2698

How To Order Additional Documentation

Use the following table to order additional documentation or information. If you need help deciding which documentation best meets your needs, call 800-DIGITAL (800-344-4825).

Telephone and Direct Mail Orders

Location	Call	Fax	Write
U.S.A.	DECdirect 800-DIGITAL 800-344-4825	Fax: 800-234-2298	Digital Equipment Corporation P.O. Box CS2008 Nashua, NH 03061
Puerto Rico	809-781-0505	Fax: 809-749-8300	Digital Equipment Caribbean, Inc. 3 Digital Plaza, 1st Street, Suite 200 P.O. Box 11038 Metro Office Park San Juan, Puerto Rico 00910-2138
Canada	800-267-6215	Fax: 613-592-1946	Digital Equipment of Canada, Ltd. Box 13000 100 Herzberg Road Kanata, Ontario, Canada K2K 2A6 Attn: DECdirect Sales
International	—	—	Local Digital subsidiary or approved distributor
Internal Orders	DTN: 264-4446 603-884-4446	Fax: 603-884-3960	U.S. Software Supply Business Digital Equipment Corporation 8 Cotton Road Nashua, NH 03063-1260

ZK-7654A-GE

Conventions

The following conventions apply to this book.

Convention	Meaning
special type	Indicates a literal example of system output or user input. In text, indicates command names, keywords, node names, file names, directories, utilities, and tools. On a DECnet-Plus for ULTRIX system, enter the word or phrase in the exact case shown.
<i>italic</i>	You can abbreviate command keywords to the smallest number of characters that OpenVMS, Digital UNIX, NCL, DECdns, DECdts, and the other utilities accept, usually three characters.
bold	Indicates a variable.
Return	Indicates a new term defined either in the text or in the glossary section of the Introduction and User's Guide manual for your operating system.
Return	Indicates that you press the Return key.

Convention	Meaning
<code>Ctrl/x</code>	Indicates that you press the Control key while you press the key noted by <i>x</i> .
[]	In command format descriptions, indicates optional elements. You can enter as many as you want.
{ }	In command format descriptions, indicates you must enter at least one listed element.

Other Conventions

- All numbers are decimal unless otherwise noted.
- All Ethernet addresses are hexadecimal.

Fault-Isolation Overview

A necessary part of any type of problem solving is fault isolation. **Fault isolation** is the process used to determine the source of a problem. Quick and efficient fault isolation is key to resolving network problems.

Topics in This Chapter

The topics in this chapter are:

- Understanding the DECnet-Plus Network Model (Section 1.1)
- Classifying Problems (Section 1.2)
- DECnet-Plus Component Relationships (Section 1.3)
- Methods for Isolating Faults (Section 1.4)

Fault-Isolation Overview

1.1 Understanding the DECnet-Plus Network Model

1.1 Understanding the DECnet-Plus Network Model

When working in the DECnet-Plus environment, it is useful to understand the network model that the DECnet-Plus software uses. Figure 1–1 illustrates the network architecture on which DECnet-Plus is based.

Figure 1–1 DECnet-Plus Network Model

DNA Application	User Application	OSI Application	Network Management
DNA Session Control		OSI Presentation	
		OSI Session	
NSP	OSI Transport (TP0, TP2, TP4)		
(ISO CLNS)	OSI Network	(ISO CONS)	
OSI Data Link			
OSI Physical			

LKG-6458-96R

1.1.1 OSI Network Layer Functions

Table 1–1 briefly describes the functions of the OSI network layers.

Table 1–1 OSI Network Layers

OSI Layer	Name	Function
7	Application	Contains the application services and supporting protocols that use the lower layers. Allows distributed processing and access.
6	Presentation	Coordinates data and data format conversion to meet the needs of individual application processes.
5	Session	Organizes and structures the interaction between pairs of communicating application processes
4	Transport	Transfers data between end systems and has error recovery and flow control. Supported protocol classes are: <ul style="list-style-type: none"> • Class 0 (TP0)—Simple protocol class for highly reliable network services • Class 2 (TP2)—Same as Class 0 with multiplexing feature • Class 4 (TP4)—Provides error detection and recovery for highly unreliable network services

(continued on next page)

Fault-Isolation Overview

1.1 Understanding the DECnet-Plus Network Model

Table 1–1 (Cont.) OSI Network Layers

OSI Layer	Name	Function
3	Network	Permits communications between network entities in open systems, whether they are adjacent systems on the same subnetwork or are connected by a path that crosses multiple subnetworks and intermediate systems. DECnet-Plus supports Connection-Oriented Network Service (CONS) and Connectionless-mode Network Service (CLNS), as well as communications between Phase IV and DECnet-Plus systems.
2	Data Link	Specifies the technique for moving data along network links between defined points on the network, and tells how to detect and correct errors in the Physical layer.
1	Physical	Connects systems to the physical communications media.

1.1.2 DNA Layer Functions

Table 1–2 briefly describes the functions of DNA network layers.

Table 1–2 DNA Network Layers

DNA Layer	Name	Function
7	DNA Application	Includes user-written programs and user-level services. It is used by operators and system programmers to plan, control, and maintain the operation of DECnet-Plus networks.
6 and 5	DNA Session Control	Allows communication between programs, regardless of either program's location through the use of DNA naming services. It also provides access control and authentication functions, and acts as a bridge between applications and the transport services.
4	Network Services Protocol (NSP)	Allows interoperability with Phase IV systems.
3, 2, and 1	Same as described in Section 1.1.1	

1.1.3 TCP/IP Interoperability

The DECnet/OSI for Digital UNIX applications, FTAM and Virtual Terminal, support RFC 1006 and can use TCP/IP transport services. This manual does not include problem-solving information for TCP/IP networks. Refer to your TCP/IP documentation for this information.

Fault-Isolation Overview

1.2 Classifying Problems

1.2 Classifying Problems

Before you try to correct problems, try to classify the type of problem that exists. The following sections describe typical problem classifications.

1.2.1 Reproducible Problems

A **reproducible problem** consistently produces the same error message or symptom when reproduced under the same conditions.

Some reproducible problems produce different error messages or symptoms that can ultimately have the same underlying cause. These types of reproducible problems are considered inconsistent. **Inconsistent problems** generally involve several protocols or several layers of an architecture. The different error messages result from the ways different applications encounter the problem in the protocols and the architectural layers.

1.2.2 Intermittent Problems

An **intermittent problem** appears occasionally and displays the same error message or symptoms in the same circumstances. You can occasionally reproduce intermittent errors. Intermittent errors can occur when threshold values for various parameters are reached. Usually, during normal use, these thresholds are not reached; however, the thresholds can be reached during peak use and errors can result.

1.2.3 Transient Problems

Transient problems occur only occasionally, and can rarely be reproduced. Because you cannot reliably reproduce transient problems, they are by far the most difficult errors to isolate and fix.

As with intermittent problems, transient problems can result when threshold values for various parameters are reached. Because transient errors tend to occur at peak usage times, historical performance data is helpful in determining the cause of the problem.

1.3 DECnet-Plus Component Relationships

Figure 1–2 and Figure 1–3 show the relationships between the individual components in the DECnet-Plus environment on OpenVMS and Digital UNIX systems. Use this information as a guide when you need to identify problems in a specific DECnet-Plus layer.

For information and problem solving procedures relating to X.400, DECDns, and DECdts software, refer to the appropriate software documentation.

1.3.1 Component Relationships (OpenVMS Only)

Figure 1–2 shows the OpenVMS component relationships.

Fault-Isolation Overview

1.3 DECnet-Plus Component Relationships

Figure 1-2 Component Relationships (OpenVMS)

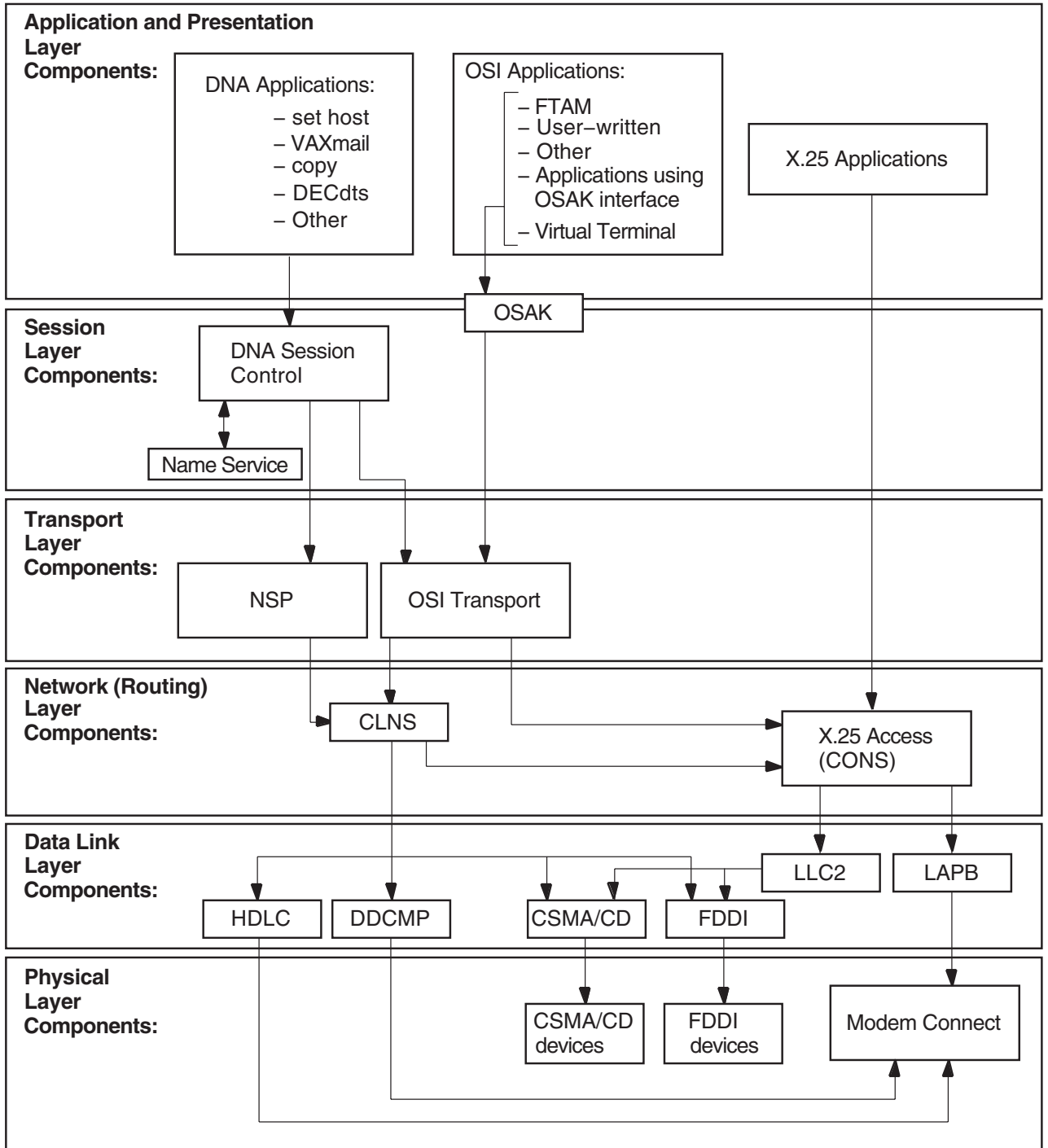

LKG-09679-96R

Fault-Isolation Overview

1.3 DECnet-Plus Component Relationships

1.3.2 Component Relationships (Digital UNIX Only)

DECnet-Plus applications that use the X/Open Transport Interface (XTI) can use the TCP transport services in addition to the OSI transport services. This manual does not contain information about TCP/IP networks; refer to your TCP/IP documentation.

Figure 1-3 shows the component relationships for Digital UNIX.

Fault-Isolation Overview

1.3 DECnet-Plus Component Relationships

Figure 1-3 Component Relationships (Digital UNIX)

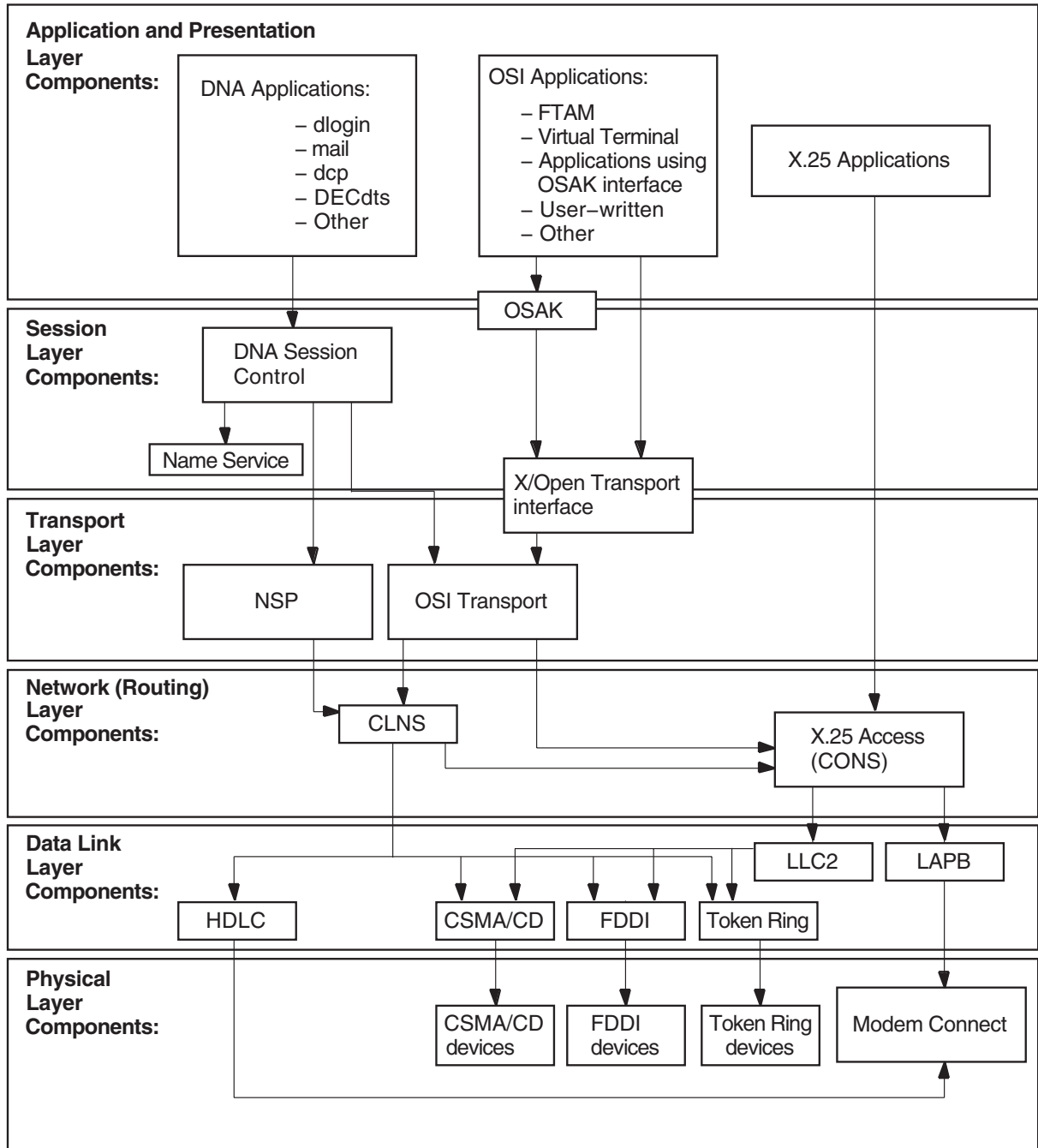

LKG-09680.96R

Fault-Isolation Overview

1.4 Methods for Isolating Faults

1.4 Methods for Isolating Faults

When attempting to isolate faults, consider the following:

- The conditions that existed when an error appeared
- The relationships between DECnet-Plus components
- The type of problem you have: reproducible or intermittent
- The changes you made prior to the error appearing

1.4.1 Questions to Ask Yourself

Answers to the following questions can help identify a starting point for problem solving:

- Which components, systems, or applications are working correctly?
- When did you first notice the problem?
- Did you see any error messages?
- What were you doing when the problem occurred?
- Can you re-create the problem?
- Did you recently add or change hardware or software?
- How often has the problem occurred since you first noticed it?

1.4.2 Fault Isolation in the DECnet-Plus Environment

Problem symptoms do not always indicate which DECnet-Plus component is the cause of the problem. To clarify where the problem exists, use another operation or application that relies on the same underlying services or components as the operation that failed.

The figures in Sections 1.3.1 and 1.3.2 show the relationship between the components in the DECnet-Plus environment.

1.4.3 DECnet-Plus Fault-Isolation Methodology

Isolating and solving network problems often requires a variety of approaches. You can use the general methodology illustrated in Figure 1–4 as a starting point for fault isolation.

Fault-Isolation Overview

1.4 Methods for Isolating Faults

Figure 1-4 Fault-Isolation Methodology (General)

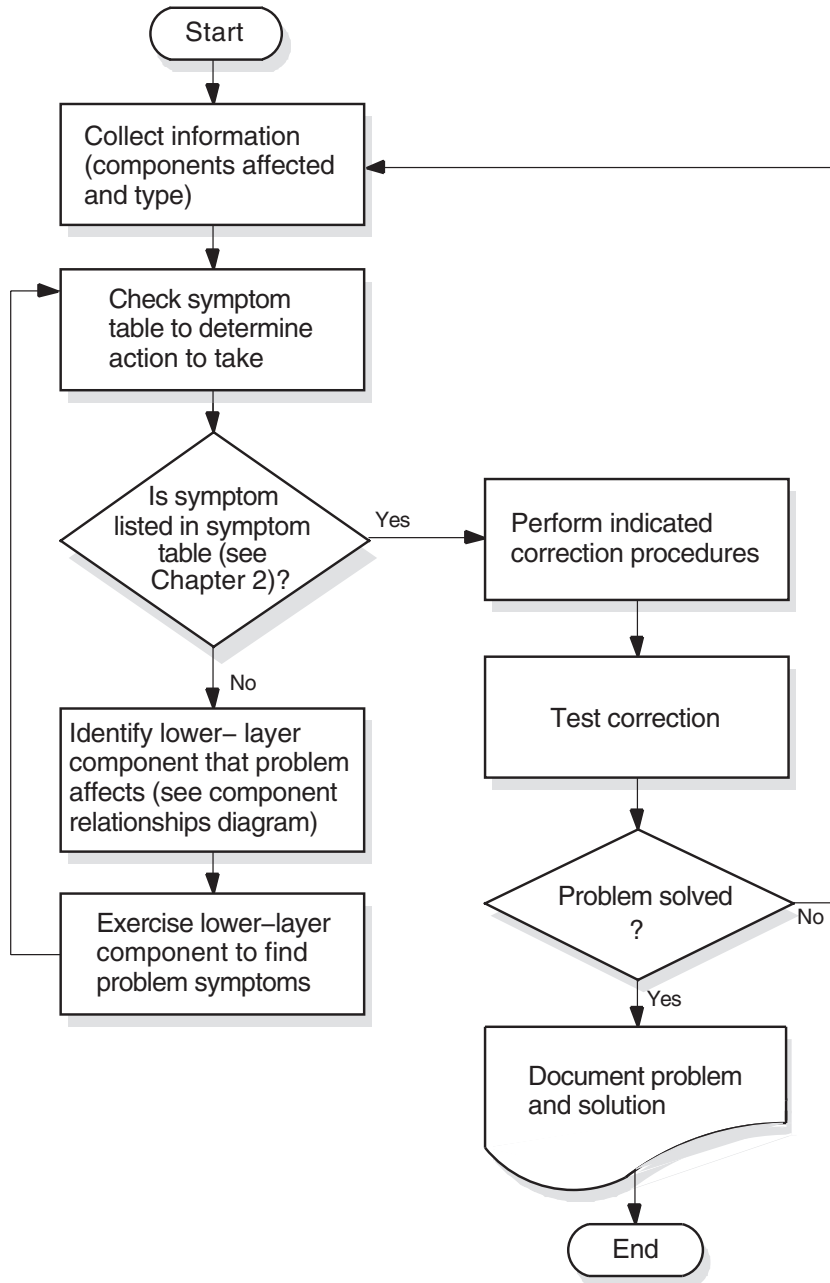

LKG-6460-96R

Fault-Isolation Overview

1.4 Methods for Isolating Faults

1.4.4 Isolating Faults for Reproducible Problems

You can use the following procedure when reproducible problems occur:

1. Find network activities that are similar, where one activity succeeds and the other fails. For example; if the OpenVMS command `set host` fails, try a similar operation to the same remote node. Then try the `set host` operation from the same local node to a different remote node.
2. Determine the most recent time when the operation succeeded. Then determine what has changed in the network since then.

1.4.5 Isolating Faults for Intermittent or Transient Problems

You can use the following procedure when intermittent or transient problems occur:

1. Collect as much information as possible regarding the state of the network when the problem appears. This information includes any type of trace information that application trace utilities provide.
2. Examine historical and trace data to determine if any patterns exist; for example, if the FTAM application fails only when attempting a directory operation on a specific vendor's system.
3. Try to reproduce the problem by re-creating the state of the system when the problem first appeared.
4. If you can reproduce the problem, follow the process described in Section 1.4.4.

1.4.6 Documenting the Fault-Isolation Process and Problem Solution

Documenting the steps you used to isolate a problem makes reporting the situation to Digital representatives easier if you are unable to solve the problem yourself.

Always record the following:

- The conditions under which problems occurred
- The hardware and software version numbers used in your network
- The processes you used to identify problems
- The information you collected about the problems
- The procedures you used to solve problems

Preparing for Problem Solving

This chapter describes the types of information that can help you isolate and correct DECnet-Plus problems.

Topics in This Chapter

The topics in this chapter are:

- DECnet-Plus Symptom Table (Section 2.1)
- Types of Problem-Solving Information (Section 2.2)
- Understanding Your Network Topology (Section 2.3)
- Recognizing Node Names and Synonyms (Section 2.4)
- Finding the Operating System and Version (Section 2.5)
- Getting DECnet-Plus Circuit Information (Section 2.6)
- Preparing to Find a Network Path (Section 2.7)
- Tracing DECnet-Plus Network Paths (Section 2.8)

Preparing for Problem Solving

2.1 DECnet-Plus Symptom Table

2.1 DECnet-Plus Symptom Table

Table 2–1 describes symptoms of common DECnet-Plus problems. Use this table when preparing to start your fault isolation process.

Table 2–1 DECnet-Plus Symptom Table

Symptom:	Possible Cause:	Refer To:
Access control rejected	Session Control application entities, proxy access, or node name validation	Chapter 6
Application failed but no errors were found in the upper layers	Transport or network error	Chapter 7 Chapter 8
Application too busy	Remote application is receiving too many connection requests before it or Session Control can process them	Chapter 6
DECnet-Plus application connection attempts fail	Application or network problem	Chapter 5 (OpenVMS only) or Chapter 8
Entities were not available when tracing a path between a routing circuit and the physical device	Routing circuit or data link is not enabled or created	Chapter 8
FTAM or Virtual Terminal responder fails (OpenVMS only)	FTAM or Virtual Terminal application	Chapter 5
FTAM file does not look correct (OpenVMS only)	FTAM application	Chapter 5
Object is unknown at remote node	Namespace problem	Chapter 6
Remote node is shut or shutting down	Remote DECnet process exited or remote node failed	Chapter 6
Remote node is unreachable	Incompatible tower information exists, or a network problem	Chapter 6 Chapter 8
Session Control has insufficient resources	All available Session Control ports are in use	Chapter 6
System configuration is correct but the routing circuit does not work	Routing connectivity	Chapter 8
Timed out	Session Control, transport or network problem	Chapter 6 Chapter 7 Chapter 8
Unable to communicate with any DECdns server	DECdns problem	DECdns manuals
Unknown application at remote node	DECnet-Plus application missing or defined incorrectly Session Control application entities or proxy access	Chapter 5 (OpenVMS only) or Chapter 6
User-written application problem affects the OSAK software (OpenVMS only)	Programming error	Chapter 5
User-written application fails	OSAK (OpenVMS only) or XTI programming error	Chapter 5 (OpenVMS only) or XTI programming manuals

(continued on next page)

Table 2–1 (Cont.) DECnet-Plus Symptom Table

Symptom:	Possible Cause:	Refer To:
User-written DECnet-Plus application terminates unexpectedly	Remote application or OSI Transport	Chapter 5 (OpenVMS only) or Chapter 7
Wrong information displayed or wrong account accessed	Proxy access problem or use of invalid username and password	Chapter 6

2.2 Types of Problem-Solving Information

The information that you often need when you try to isolate and solve DECnet-Plus problems includes:

- The type of problem (see Section 1.2)
- Network topology, including:
 - Node names and types (end node, level 1 router, level 2 router)
 - Operating system
 - Networking software in use
 - Types of routing circuits in use
 - Routing circuit adjacencies
 - The network path from one node to another
- Naming information (node names and Phase IV node synonyms)

2.2.1 Definitions

A **network topology** shows the physical and logical locations of components in a network. A current map of the physical and logical locations of all of the devices on your network is important in helping you find specific devices quickly.

A **Phase IV node synonym** is a Phase–IV–style node name that enables applications that do not support the length of a DECnet-Plus full name to continue to use a six–character Phase–IV–style node name.

A **routing circuit** is a logical path between adjacent nodes. DECnet Phase IV circuit names are based on the hardware type used by the lines connecting nodes. A DECnet-Plus circuit name can be in any format.

A **network path** is the path data takes from one end system to another end system in the same or a different area.

2.2.2 Tools and Commands to Use

Table 2–2 shows the tools and commands you can use to find information about your network.

Preparing for Problem Solving

2.2 Types of Problem-Solving Information

Table 2-2 Problem Solving Tools and Commands

To Find:	Use:	And Refer To:
Network protocol information	Common Trace Facility	<i>Common Trace Facility Use</i> manual
	DECnet-Plus application traces (OpenVMS only)	Chapter 5
	Network Control Language	NCL reference documentation
Network topology	NCP for Phase IV nodes	DECnet Phase IV documentation
	NCL for DECnet-Plus nodes	DECnet-Plus NCL reference documentation
	decnet_migrate for networks that use Digital's WANrouter products	DECnet-Plus network management documentation
Routing circuit adjacencies	NCP for Phase IV nodes	DECnet Phase IV documentation
	NCL for DECnet-Plus nodes	DECnet-Plus network management documentation
Node reachability	The following for quick reachability tests:	Chapter 3
	<ul style="list-style-type: none"> The Digital UNIX command <code>dlogin address</code> or the OpenVMS command <code>set host address</code> The Digital UNIX command <code>dls address</code> or the OpenVMS command <code>directory address</code> OSI Ping for Digital UNIX systems only 	
	Loopback and <code>dts/dtr</code> tests for more detailed testing	Chapter 3
DECnet software version	For DECnet-Plus nodes, the NCL command <code>show node node-id</code> implementation	DECnet-Plus NCL reference documentation
	For Phase IV nodes, the NCP command <code>tell node-id show exec</code>	DECnet Phase IV management documentation

2.3 Understanding Your Network Topology

There are many ways to collect network topology information. Two methods are:

- Creating reports using the `decnet_migrate` tool
- Tracing potential data paths from one end system to another using the `decnet_migrate` tool

2.3.1 The `decnet_migrate` Tool

You can use the `decnet_migrate` tool to get the following information for each node in your network:

- Basic information, including:
 - Name
 - Address
 - Type of DECnet software in use (Phase IV or DECnet-Plus)
 - Routing type
 - Node identification string
- Adjacent nodes for each node
- Defined target network applications (or objects) for each node
- Routing circuit IDs and costs for each node
- Maximum routing hops, cost, and network buffer size
- Areas known to level 2 routers in the network

You can also use the `decnet_migrate show path` function to trace network routes between one node and another.

2.3.2 When to Use the `decnet_migrate` Tool

Use this tool when you need a detailed map of parts or all of the complete network topology. If you have routers that use the Simple Network Management Protocol (SNMP), the `decnet_migrate` tool cannot collect information about them. Use the tools those routers provide to collect network topology information.

Collecting this information with the `decnet_migrate` tool can take a significant amount of time depending on the options you select.

2.3.3 References

The DECnet-Plus network management documentation explains how to use the `decnet_migrate` commands `collect`, `report`, and `show path` in detail. Sections 2.8.1 and 2.8.2 describe which NCL and NCP commands to use to trace network paths in the DECnet-Plus environment.

Preparing for Problem Solving

2.4 Recognizing Node Names and Synonyms

2.4 Recognizing Node Names and Synonyms

It is useful to have node name information when trying to isolate faults. Node names reflect either a Phase IV or DECnet-Plus style.

2.4.1 Identifying Node Names

Table 2–3 shows the differences between Phase IV and DECnet-Plus node names.

Table 2–3 Phase IV and DECnet-Plus Node Name Differences

Characteristics	Example
Phase IV node names are:	MYNODE
<ul style="list-style-type: none">• Up to six alphanumeric characters• Stored in a local network database	
DECnet-Plus node names are:	ABC:.eng.node1
<ul style="list-style-type: none">• Typically, longer than six alphanumeric characters• Divided into the following elements:<ul style="list-style-type: none">– Namespace nickname for DECdns or Local for the Local namespace– Directory names– Node name• Stored in the DECdns distributed namespace or the Local namespace.	

2.4.2 Finding Node Names and Node Synonyms

Use the following commands to find a system's node synonym or to find a DECnet-Plus full node name from a system's node synonym:

To Find A:	Use This decnet_register Command:
Phase IV synonym	<code>decnet_register>show node <i>node-id</i></code>
Full node name	<code>decnet_register>show node <i>node-id</i></code>

2.5 Finding the Operating System and Version

Do the following to find your system's current operating system and version:

1. Log in to the system and look at the system prompt.

If the Prompt Is:	Then the Operating System Is:
Username:	OpenVMS
login:	Digital UNIX

2. If the operating system version does not appear when you log in, enter one of the following commands:

If the Operating System Is:	Enter:
OpenVMS	\$ show system
Digital UNIX	# strings /vmunix grep '(Rev)'

2.6 Getting DECnet-Plus Circuit Information

To find basic routing circuit information, use Network Control Program (NCP) commands for Phase IV nodes and Network Control Language (NCL) commands for DECnet-Plus nodes. Refer to your NCP documentation for information about NCP commands.

2.6.1 Routing DECnet-Plus Circuit Information for Problem Solving

The following information can be useful when you need to solve routing circuit problems:

- Routing circuit name
- Routing circuit type
- Routing circuit state
- Routing circuit adjacencies

2.6.2 Finding Routing Circuit Names, Types, States, and Adjacencies

Do the following to find a circuit name, type, and state:

To Find Routing Circuit:	Enter This NCL Command:
Name	ncl>show node <i>node-id</i> routing circuit * name
Type	ncl>show node <i>node-id</i> routing circuit * type
State	ncl>show node <i>node-id</i> routing circuit * state

Routing circuit adjacencies result from nodes exchanging identification information. Finding circuit adjacencies is a quick way to:

- Confirm that a routing circuit is working
- Check the identity of the adjacent node

Routing circuit adjacencies exist for wide area network (WAN) circuits, and local area network (LAN) circuits. Use the following NCL command to find routing circuit adjacencies:

```
ncl>show node node-id routing circuit circuit-id -  
_ncl>adjacency * all status
```

2.6.3 Considerations for Broadcast Circuit Adjacencies

When you look at broadcast circuit adjacencies, the output can be extensive because many adjacencies can exist at one time. It can be more useful to request certain types of information rather than *all* information.

For example, you could use the following NCL command:

```
ncl>show node node-id1 routing circuit circuit-1 adjacency -  
_ncl>node-id2 type
```

Preparing for Problem Solving

2.7 Preparing to Find a Network Path

2.7 Preparing to Find a Network Path

Tracing a path from one end system to another can isolate network reachability problems and also can provide network topology information. The information in this section describes the type of information you need before you trace a network path.

2.7.1 Types of Network Information to Find

Use the Network Control Program (NCP) to get network path information from Phase IV nodes. Use the Network Control Language (NCL) to get network path information from DECnet-Plus nodes. Table 2-4 lists the information you need to trace a network path and how to identify this information.

Table 2-4 Types of Network Information to Trace

Information	Description								
Node Addresses	<p>Nodes have addresses that DECnet uses when sending data through a network. Phase IV nodes only have one node address; DECnet-Plus nodes can have up to six NSAP addresses; three that NSP use and three that OSI Transport use.</p> <p>Phase IV node addresses and NSAP addresses are different. However, you can translate a Phase IV node address into an NSAP address.</p> <hr/> <table border="0"> <tr> <td style="vertical-align: top;">Phase IV Node Addresses:</td> <td style="vertical-align: top;">NSAP Addresses:</td> </tr> <tr> <td style="vertical-align: top;">Are called node numbers.</td> <td style="vertical-align: top;">Are called network service access points (NSAPs).</td> </tr> <tr> <td style="vertical-align: top;">Are 2 bytes in length.</td> <td style="vertical-align: top;">Can be up to 20 bytes (40 hexadecimal digits) in length.</td> </tr> <tr> <td style="vertical-align: top;">Contain an area number (1 – 63) and a node number (1 – 1023).</td> <td style="vertical-align: top;"> DECnet-Plus Phase IV-compatible addresses contain: <ol style="list-style-type: none"> 1. Phase IV prefix (the IDP-Initial Domain Part). 2. Local area number - this is equivalent to a Phase IV area number. 3. ID; a 6-byte field that is formatted like a 48-bit IEEE address and uniquely identifies a node within its area. This is equivalent to a Phase IV node number. 4. A 1-byte NSAP selector that identifies the user of the Network layer, either NSP or OSI transport. The hexadecimal number %x21 indicates OSI transport; the hexadecimal number %x20 indicates NSP. </td> </tr> </table>	Phase IV Node Addresses:	NSAP Addresses:	Are called node numbers.	Are called network service access points (NSAPs).	Are 2 bytes in length.	Can be up to 20 bytes (40 hexadecimal digits) in length.	Contain an area number (1 – 63) and a node number (1 – 1023).	DECnet-Plus Phase IV-compatible addresses contain: <ol style="list-style-type: none"> 1. Phase IV prefix (the IDP-Initial Domain Part). 2. Local area number - this is equivalent to a Phase IV area number. 3. ID; a 6-byte field that is formatted like a 48-bit IEEE address and uniquely identifies a node within its area. This is equivalent to a Phase IV node number. 4. A 1-byte NSAP selector that identifies the user of the Network layer, either NSP or OSI transport. The hexadecimal number %x21 indicates OSI transport; the hexadecimal number %x20 indicates NSP.
Phase IV Node Addresses:	NSAP Addresses:								
Are called node numbers.	Are called network service access points (NSAPs).								
Are 2 bytes in length.	Can be up to 20 bytes (40 hexadecimal digits) in length.								
Contain an area number (1 – 63) and a node number (1 – 1023).	DECnet-Plus Phase IV-compatible addresses contain: <ol style="list-style-type: none"> 1. Phase IV prefix (the IDP-Initial Domain Part). 2. Local area number - this is equivalent to a Phase IV area number. 3. ID; a 6-byte field that is formatted like a 48-bit IEEE address and uniquely identifies a node within its area. This is equivalent to a Phase IV node number. 4. A 1-byte NSAP selector that identifies the user of the Network layer, either NSP or OSI transport. The hexadecimal number %x21 indicates OSI transport; the hexadecimal number %x20 indicates NSP. 								
Network entity titles (NETs)	Used to identify a node when it is not necessary to identify the transport software in use. A NET has the same format as an NSAP with a selector byte of %x00.								
System type	A system can be an end system, a level 1 router, or a level 2 router.								

2.7.2 Finding Node Addresses for Node Names

A Phase IV node has one address; a DECnet-Plus node can have multiple NSAP addresses. You can determine a node's address as follows:

For This Node Type:	Enter:
Phase IV	The NCP command: tell <i>node-spec</i> show exec
DECnet-Plus	The NCL command: show node <i>node-id</i> routing port * nsap address

If you cannot get the remote node's address in this manner, you need to log in to that system directly.

2.7.3 Determining Network Entity Titles for DECnet-Plus Nodes

A network entity title (NET) has the same format as a system's network service access point (NSAP), except the last two digits are set to 00. For example, if the NSAP is 49::00-0D:AA-00-04-00-7F-34:20, the NET is 49::00-0D:AA-00-04-00-7F-34:00.

2.7.4 Converting Phase IV Addresses to NSAPs

If you know a system's Phase IV address, you can do the following to convert it to an NSAP (see your DECnet introduction documentation for details about NSAPs):

Step	Action
1	Ensure that the NSAP local area is in the Phase IV area in hexadecimal notation. For example, the Phase IV area 1 becomes the NSAP local area 00-01, and the Phase IV area 63 becomes the NSAP local area 00-3F.
2	Convert the Phase IV node ID to the NSAP node ID: <ol style="list-style-type: none"> a. Use the formula (area * 1024) + ID to convert the Phase IV area and ID to a single decimal value. b. Convert the value from step (a) to a four-digit hexadecimal number, and swap the first and last pairs of the hexadecimal digits. c. Use the number from step (b) as the last four digits of the NSAP's node ID field, and add the prefix aa-00-04-00.

Example of Phase IV Address Conversion

In this example, the network IDP (initial domain part) is 41:45436192:, the DSP (domain-specific part) is local-area:node-id:20, the Phase IV address is 43.258, and the node uses the NSP transport. You create the NSAP as follows:

```
IDP and selector    -> 41:45436192:local-area:node-id:20
43 decimal          -> 2B      hexadecimal (local area)
(43 * 1024) + 258) -> 44290   decimal
44290 decimal       -> AD02   hexadecimal
AD02 swapped       -> 02AD   hexadecimal (node ID)
Resulting NSAP     -> 41:45436192:00-2b:aa-00-04-00-02-ad:20
```

Preparing for Problem Solving

2.7 Preparing to Find a Network Path

2.7.5 Converting NSAP Addresses to Phase IV Format

If you know a system's NSAP, you can do the following to convert it to a Phase IV address:

Step	Action
1	Check that the local area is less than or equal to 63 decimal or 3F hexadecimal and the node ID field begins with aa-00-04-00. If both of these conditions do not exist, then the NSAP does not contain a Phase IV address and cannot be converted. If it does, go to the next step.
2	Extract the last four digits of the node ID field.
3	Swap the last two pairs of digits, and convert the value to decimal.
4	Calculate the Phase IV area and ID values: a. $area = value / 1024$ b. $id = value - (area * 1024)$ If the calculated area value is not equal to the area value obtained from the NSAP's local area field, the NSAP does not contain a valid Phase IV address.

Example of NSAP Conversion

In this example, the NSAP is 37:81076541234:00-19:aa-00-04-00-62-64:21. You calculate the Phase IV address as follows:

```
19 hexadecimal (from local area)  -> 25 decimal
62-64 (from node-id)              -> 6462 hexadecimal
6462 hexadecimal                  -> 25698 decimal
25698/1024                         -> area of 25
25698 - (25 * 1024)                -> node ID of 98
Resulting Phase IV address         -> 25.98
```

2.8 Tracing DECnet-Plus Network Paths

You can trace a network path for a pure DECnet-Plus environment and for a mixed environment that has DECnet-Plus and Phase IV nodes.

2.8.1 Tracing the Network Path of DECnet-Plus Nodes

You can trace the path from one node to another with the following command:

```
$ run decnet_migrate
DECNET_MIGRATE>sho path from
NAMES:.NETA.NODEA to NAMES:.NETB.NODEB
```

Do the steps in the following table to trace a network path from one DECnet-Plus end system to another:

Step	Action
1	Find the destination NSAPs.
2	Analyze the NSAPs to find the area addresses of the destination system.

Preparing for Problem Solving 2.8 Tracing DECnet-Plus Network Paths

Step	Action
3	<p>Find a DECnet-Plus router that the source node uses. Do the following:</p> <ol style="list-style-type: none">Find the source node's routing circuits. Use the following NCL command: <pre>ncl>show routing circuit * all</pre>Select a circuit whose state is ON, and use the following NCL command to display the NET of the associated router: <pre>ncl>show routing circuit <i>circuit-id</i> - _ncl>adjacency * all</pre><p>The LAN address in the display may show the actual node name of the router. You can use this or the NET in this procedure. A LAN address is not displayed in all situations. For example, if tracing a path from an X.25 DA circuit, no LAN address is displayed.</p><p>A DECnet-Plus router may not exist. See the procedure in Section 2.8.2 if the next node in the path is a Phase IV router. If the next node in the path is not a Digital router, see that system's documentation.</p>
4	<p>If the router you find in the previous step is in the same area as your destination node, go to the next step. If the router is in a different area than the destination node, do the following:</p> <ol style="list-style-type: none">Search the router's destination area database for the destination area. Use the following NCL command (on OpenVMS systems, the <i>router-id</i> is the router's node name or the NSAP without punctuation and prefixed with net\$ – for example, net\$490013AA00040089FF20; on Digital UNIX systems, the <i>router-id</i> can be the router's NET or the node name): <pre>ncl>show node <i>router-id</i> routing - _ncl> destination area <i>destination-area</i> all</pre><hr/><p style="text-align: center;">Note</p><hr/><p style="text-align: center;">You can also use the <code>decnet_register</code> utility to display information about node names.</p><hr/>Look at the routing circuit adjacency that the previous command displays. Use the following NCL command (On Digital UNIX systems, the <i>router-id</i> can be the router's NET or the node name): <pre>ncl>show node <i>router-id</i> routing - _ncl>circuit <i>circuit-id</i> adjacency - _ncl>adjacency-<i>id</i> all</pre><p>This command displays the NET for the next router in the path. If the next router is not in the same area as the destination node, repeat steps (a) and (b) until you locate a router in the same area.</p>

Preparing for Problem Solving

2.8 Tracing DECnet-Plus Network Paths

Step	Action
5	<p>When you find a router located in the same area as the destination node, do the following:</p> <ol style="list-style-type: none"> Search the router's destination node database to find the circuit adjacency that the router uses to reach the next node in the path. Use the following NCL command: <pre>ncl>show node <i>router-id</i> routing destination - _ncl>node <i>node-id</i> all</pre> Show the routing adjacency to determine the next node in the path. Use the following NCL command: <pre>ncl>show node <i>router-id</i> routing circuit - _ncl><i>circuit-id</i> adjacency <i>adjacency-id</i> all</pre> If the adjacency leads to another router, repeat steps (a) and (b) until you reach the adjacency that connects to the destination node.

2.8.2 Tracing a Network Path in a Mixed Environment

Your network can contain DECnet-Plus and Phase IV nodes. If you start to trace a path from a DECnet-Plus node and the next router in the path is a Phase IV router, do the following:

Step	Action
1	Exit NCL and invoke NCP (or invoke NCP at the NCL prompt).
2	Use NCP to get the Phase IV node address of your destination node and the router.
3	<p>Find the next node in the path. Use the following NCP commands (the <i>router-id</i> can be the node name or the Phase IV address):</p> <pre>ncp>tell <i>phase_iv-node-id</i> show node - _ncp><i>destination-node-address</i></pre>
4	If the next node in the path is not the destination node, repeat the commands in step 3, using the next node that the show node command displays as the <i>next-node-id</i> , until you reach the destination node.
5	<p>If NCP returns an error message, the next node in the path could be a DECnet-Plus node. Do the following:</p> <ol style="list-style-type: none"> Exit NCP and invoke NCL. Repeat steps 4 or 5 in Section 2.8.1.

2.8.3 X.25 DA Circuit Considerations

If you are tracing a network path from an X.25 DA circuit, you cannot use NSAP or NET information to find the next node in the path. Use the following procedure to help you trace a path from an X.25 DA circuit:

Step	Action
1	Find the reachable address subentity that has a prefix that best matches your required destination NSAP.
2	Select a DTE from the DTE Addresses attribute and determine the node address (NSAP or Phase IV synonym) associated with the remote DTE address.

Preparing for Problem Solving

2.8 Tracing DECnet-Plus Network Paths

Step	Action
3	If you cannot determine the node address, try to log in to the remote node using X.29 (PAD) and continue tracing the network path from the remote node.

2.8.4 NCL Takes Long Time While Translating Addresses to Names

When NCL displays a node address in response to a SET or SHOW command, it uses the services of DECdns to translate the address into a node name and displays the name along with the address.

If there is a problem with accessing a remote name server that prevents the translation from completing, NCL may take a long time translating addresses to names. If this happens, enter a Ctrl/Y to terminate NCL, then make the following definition prior to executing NCL:

```
$ DEFINE NCL$ENVIRONMENT NOBACKTRANS
```

This causes NCL to bypass the address-to-name translation. To use this option on a systemwide basis, add this logical definition (with the /SYSTEM qualifier) to SYS\$MANAGER:NET\$LOGICALS.COM.

Testing Network Reachability

This chapter describes the network reachability tests you can use in the DECnet-Plus environment.

Topics In This Chapter

The topics in this chapter are:

- Types of Network Reachability Tests (Section 3.1)
- OSI Echo Function Overview (Digital UNIX Only) (Section 3.2)
- Node-Level Loopback Tests Overview (Section 3.3)
- Running Node-Level Loopback Tests (Section 3.4)
- Circuit-Level Loopback Test Overview (Section 3.5)
- Preparing for Circuit-Level Loopback Tests (Section 3.6)
- Running Circuit-Level Loopback Tests (Section 3.7)
- Running Circuit-Level Loopback Tests with Assistance (Section 3.8)
- Running LAN Loopback Tests with LLC Messages (Section 3.9)
- Running dts/dtr Tests (Section 3.10)
- Running dts/dtr Connect Tests (Section 3.11)
- Running dts/dtr Data Tests (Section 3.12)
- Running dts/dtr Disconnect Tests (Section 3.13)
- Running dts/dtr Interrupt Tests (Section 3.14)

Testing Network Reachability

3.1 Types of Network Reachability Tests

3.1 Types of Network Reachability Tests

You can use the following network reachability tests:

Test	Description
Quick reachability	Provides a fast indication that a remote node is reachable using applications such as <code>dlogin</code> or <code>set host</code> with the node address instead of the node name. If you cannot connect to a node using its node name but can connect to it using the address, the cause could be a naming service problem. For Digital UNIX systems, you can also use OSI Echo function (OSI ping).
Loopback	Loopback tests (node level, circuit level, and LAN with LLC test messages) let you thoroughly use network software and hardware by sending data through various network components and returning that data to its source for comparison.
DECnet Test Sender and Receiver (<code>dts/dtr</code>)	Throughput tests that allow you to load test the ability of different systems to exchange data. The <code>dts/dtr</code> tests are also useful if you want to check Transport layer connections. Parameters are available to regulate such variables as message length, test duration, and type of data used.
X.25 and OSI Transport IVP (OpenVMS systems only)	These tests check if the X.25 or OSI transport software is working correctly. Your installation documentation describes them.

3.1.1 Types of Loopback Tests

You can use the loopback tests described in this section for DECnet-Plus systems. Refer to your DECnet Phase IV documentation if you need details about similar tests for Phase IV systems.

Test Type	Description
Node level	Checks the logical link capabilities of a node by exchanging test data between DECnet tasks in two different nodes or in the same node. You use <code>NCL</code> to run this test, which enables you to connect to a loopback mirror application. The types of node-level tests are: <ul style="list-style-type: none">• Local-to-Local loopback tests, which evaluate the local node's DECnet software using an internal logical link path; no physical device is used.• Local-to-Remote loopback tests, which verify network operation between the local node and a remote node.
Circuit level	Checks a DECnet circuit by looping test data between a <code>mop</code> task and the communication hardware on one or two systems.

Testing Network Reachability

3.1 Types of Network Reachability Tests

3.1.2 Using Loopback Tests on Phase IV Nodes

To perform loopback tests when logged in to a Phase IV node, use NCP commands (see your DECnet Phase IV documentation for details). To perform loopback tests when logged in to a DECnet-Plus node, use NCL commands, even if you are testing a remote Phase IV node.

3.1.3 Types of dts/dtr Tests

The dts/dtr program provides the following basic tests:

Test	Description
Connect test	Verifies that the receiving node (dtr node) can process connection requests and return acceptance and rejection messages with or without optional user data.
Data test	Provides a full range of tests from very simple data sink operations through data integrity checking.
Disconnect test	Verifies that the receiving node (dtr node) can send out disconnect messages with or without optional user data.
Interrupt test	Provides a full range of test capabilities from very simple data sink operations through data integrity checking.

3.2 OSI Echo Function Overview (Digital UNIX Only)

DECnet/OSI for Digital UNIX implements an OSI Echo function (OSI ping). This function enables an ISO 8473 network-entity to generate a special type of PDU, the Echo Request PDU, also known as OSI ping, which is sent to the requested destination in order to elicit an Echo Response PDU from that destination.

This implementation supports both RFC 1139 and Amendment X to ISO 8473. It is important to realize that not all OSI systems support the OSI Echo function. Consequently, an attempt to ping such a system will not succeed even though that system is functioning normally.

3.2.1 OSI ping Command Syntax

The OSI ping command syntax is:

```
/usr/sbin/oping [options] host [datasize] [npackets]
```

The host is a DECnet/OSI node name, node synonym or NSAP (preceded by %x). For example:

```
abc:.xyz.node1
node1
%x49000caa000400192000
```

The following table describes the optional arguments for this command:

Option	Description
Options	
-l	More verbose statistics are printed, including packet sequence and round-trip time estimate.
-s	Uses the <i>short term implementation</i> of RFC 1139 (see Section 3.2.2). Same statistics as for the -l option are printed.

Testing Network Reachability

3.2 OSI Echo Function Overview (Digital UNIX Only)

Option	Description
<code>datasize</code>	If no data size is specified, the default value of 64 bytes is used for the data portion.
<code>npackets</code>	If no <code>npackets</code> are specified and the <code>-l</code> option is used, <code>oping</code> will send approximately 1 echo request per second until stopped by the user. If <code>npackets</code> is specified, exactly <code>npackets</code> echo requests will be sent.

3.2.2 Restrictions

Several different implementations of OSI Echo function exist in the industry. Before Amendment X to ISO8473 existed, various vendors implemented RFC 1139 (an Echo function for ISO 8473).

RFC 1139 offers two possible implementation mechanisms. The first, called "The Short Term Implementation Mechanism" uses special NSAP selectors in the data PDUs conveying the echo messages. The second, called "The Long Term Implementation Mechanism," uses special PDU types for Echo request and Echo Response PDUs.

Amendment X to ISO 8473 implements the "Long Term Mechanism" which OSI ping uses by default. To interoperate with the "Short Term Implementation Mechanism", use the `-s` option if an attempt to ping a system using the default mechanism fails.

3.3 Node-Level Loopback Tests Overview

Use the node-level loopback tests first; if further testing is desired, use the circuit-level loopback tests.

3.3.1 When to Use Node-Level Loopback Tests

Use the local-to-local loopback test to verify operation of the local Network, Application, Session Control, Transport layers, and part of the Routing layer.

Use the local-to-remote loopback test to verify operation of all levels of network software on the local and remote nodes you are testing.

3.3.2 Analyzing Local-to-Local Node Loopback Test Results

If a looped message returns with an error, the test stops and NCL displays a message specifying the reason for the failure. If the loopback test completes successfully, there is no output.

A failure of this test indicates a problem with the local node software, such as the network being turned off or access control to the mirror not being properly established. If the local-to-local loopback test fails, check the log file for additional information on the cause of the failure.

If the local-to-local loopback test succeeds, perform a local-to-remote loopback test. If the local-to-remote test fails, try the circuit-level tests to determine if the hardware is at fault.

3.3.3 Log File for Local-to-Local Node Loopback Tests

The OpenVMS log file for local-to-local loopback test failures is `net$server.log`. You find this file in the `mirro$server` account if you set up a mirror account when you installed the DECnet-Plus software. If the mirror account does not exist, the location of the `net$server.log` file depends on the type of account from which the test is initiated.

For example, if the account from which the test initiates has an account on the target system, then the `net$server.log` file is located in the account on the target system. If this account does not exist on the target system, the connection is not completed. Additionally, if the initiating system uses a proxy account to connect to the target system, then the `net$server.log` file is found in the proxy account.

The Digital UNIX log file for local-to-local loopback test failures is `/usr/adm/syslog.dated/dd-mmm-hh.mm/daemon.log`.

3.3.4 Local-to-Local Node Loopback Figure

Figure 3–1 illustrates a local-to-local loopback test.

Figure 3–1 Local-to-Local Loopback Test

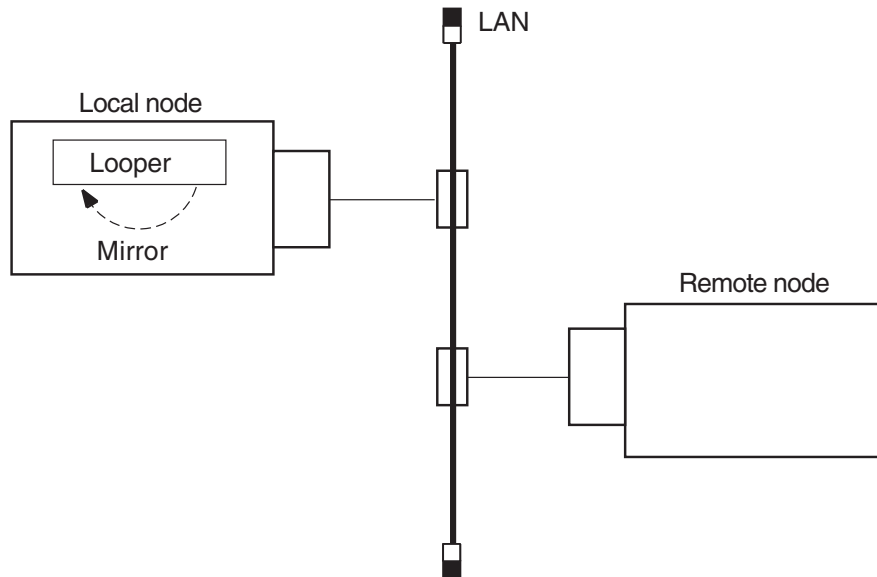

LKG-0267-96R

3.3.5 Analyzing Local-to-Remote Node Loopback Test Results

If the previous local-to-local tests were successful and this test fails, a problem exists with either the remote node or the network. Try the test again with a different remote node. If the second test succeeds, a problem with the first remote node that you used probably caused the failure. If the test fails, a network problem probably caused the failure.

Testing Network Reachability

3.3 Node-Level Loopback Tests Overview

3.3.6 Local-to-Remote Loopback Test Figure

Figure 3–2 illustrates a local-to-remote loopback test.

Figure 3–2 Local-to-Remote Loopback Test

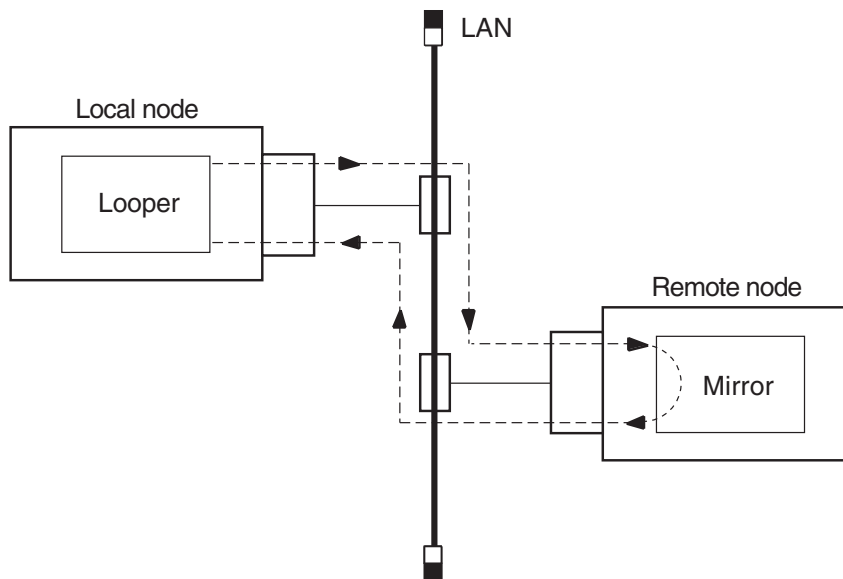

LKG-3776-96R

3.4 Running Node-Level Loopback Tests

When you start this test, identify the node to which you want to loop test messages with the node's full name. This node must be reachable over circuits that are in the On state.

Use the following NCL command to start a node-level loopback test:

```
ncl>loop [node node-id] loopback application [parameter,] -
_ncl>name node-id
```

The node *node-id* parameter identifies the node from which you start the test. The default value of this parameter is 0. The name *node-id* parameter identifies the node to which you want to loop.

3.4.1 Node-Level Loopback Command Parameters

You can specify any of the following optional parameters:

Parameter	Description
format	Specifies the type of binary information used to perform the test. Specify this value as a pair of hexadecimal digits such as format=FF. The hexadecimal value 55, a combination of ones and zeros, is the default.
count	Specifies the number of data blocks to be sent during the test. Specify a number from 1 (default) through 65,535.

Testing Network Reachability

3.4 Running Node-Level Loopback Tests

Parameter	Description
length	Specifies the length in bytes of each block to be looped. This value must be a decimal integer from 1 through n . The value of n must be less than the smaller buffer size of the two tasks involved in the test. The default is 40 bytes.

3.4.2 Example of Node-Level Loopback Test

In the following test, a network manager attempts to loop 10 messages to node BOSTON. The result is that the message is not looped because node BOSTON is unreachable.

```
ncl> loop loopback application count 10, name boston
node 0 Loopback Application at 1991-04-22-13:00:27.725-04:00I0.212

FAILED IN DIRECTIVE: Loop DUE TO: Error specific to this entity's class

REASON: Connection Failed
Description: The Connection to the remote mirror failed
ncl>
```

3.5 Circuit-Level Loopback Test Overview

These tests use a low-level data link interface rather than the logical links used by the node-level tests. They use DECnet software to loop data through the circuit-to-circuit service software in the adjacent node and back to the local node. You can specify optional parameters for assistance in testing a remote node (see Section 3.8.4).

On non-LAN circuits, you can loop test data through a passive loopback connector or through an active remote system. On LAN circuits, the remote system ultimately returns the test data.

3.5.1 Circuit-Level Loopback Test Figure

Figure 3-3 illustrates a circuit-level loopback test.

Testing Network Reachability

3.5 Circuit-Level Loopback Test Overview

Figure 3-3 Circuit-Level Loopback Test

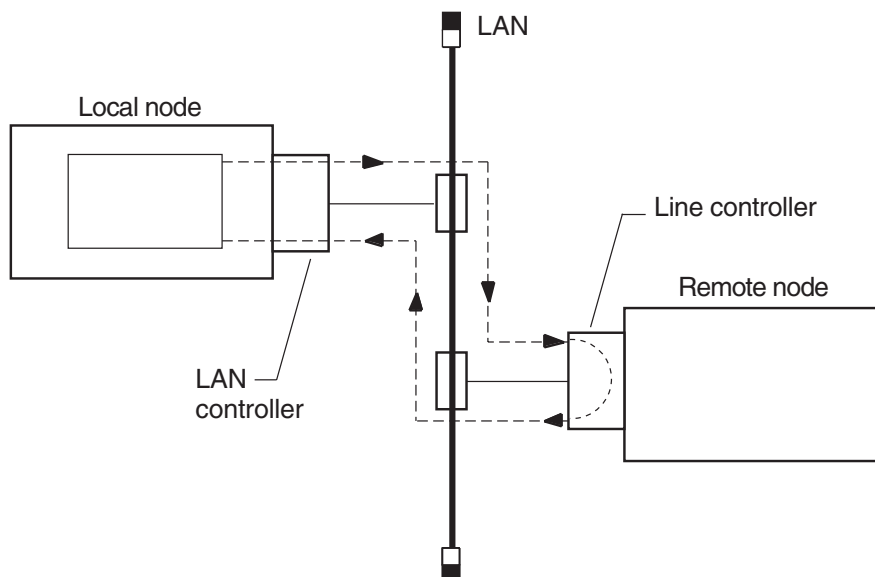

LKG-3775-96R

3.5.2 Identifying Node Addresses for Circuit-Level Loopback Tests

Unique Ethernet addresses identify nodes on Ethernet circuits. If the node is running DECnet Phase IV, or is a DECnet-Plus node that has a Phase IV node synonym, this physical address is the one that DECnet created using the DECnet node address. If the node is not running DECnet, the physical address is the default hardware address of the node.

3.6 Preparing for Circuit-Level Loopback Tests

Do the following before you run a circuit-level software loopback test:

Step	Action
1	Use the NCL command <code>show mop state</code> to check that the mop entity is in the On state.
2	Use the NCL command <code>show mop circuit * name, function</code> to check that the circuit to be tested has loop requester function enabled.
3	<p>If the mop entity or the circuit is not in the appropriate state, use the NCL commands <code>create mop circuit <i>circuit-id</i> type <i>type-id</i></code> to start them. For example, you could use the following commands:</p> <pre>ncl>create mop circuit csmacd-0 type csma-cd</pre> <p>This creates the MOP circuit, <code>csmacd-0</code>.</p> <pre>ncl>set mop circuit csmacd-0 link name - _ncl>csma-cd station csmacd-0</pre> <p>This customizes the entity definition for the circuit <code>csmacd-0</code>.</p> <p>You can also start them with an NCL command script, such as <code>/var/share/dna/scripts</code> on a Digital UNIX system.</p> <p>On an OpenVMS system, you can use: <code>@sys\$system:startup network mop</code></p>

Testing Network Reachability

3.6 Preparing for Circuit-Level Loopback Tests

Step	Action
4	Determine the physical device associated with a mop circuit as follows: <ol style="list-style-type: none">Use the NCL command <code>show mop circuit <i>circuit-id</i> all characteristics</code> to show the circuit characteristics.Use the NCL command <code>show data link all status</code> to show the status of the corresponding data link.

3.6.1 Example of Circuit-Level Loopback Preparation

In this example, the output from the NCL commands shows:

- The mop entity is in the On state.
- Circuit-1, the circuit to be tested, has the loopback function enabled.
- mop circuit circuit-1 is associated with device xna0.

```
1 ncl> show mop state
```

```
Node 0 MOP
AT 1994-1-04-1-13:27:12/325-05:00I0.176
```

```
Status
```

```
State = On
```

```
2 ncl> show mop circuit * name, function
```

```
Node 0 MOP Circuit *
AT 1994-04-1-13:27:30.095-05:00I0.178
```

```
Identifiers
```

```
Name = circuit-1
```

```
Status
```

```
Functions = {
                Loop Requester,
                Load Requester,
                Load Server,
                Dump Server
            }
```

```
3 ncl> show mop circuit circuit-1 all char
```

```
Node 0 MOP Circuit circuit-1
AT 1992-04-01-13:38:27.747-05:00I0.198
```

```
Characteristics
```

```
Type = CSMA-CD
Link Name = CSMA-CD Station csmacd-1
Retransmit Timer = 4
Known Clients Only = False
```

```
ncl> show csma-cd station csmacd-1 all status
```

```
Node 0 CSMA-CD Station csmacd-1
AT 1992-04-01-13:39:27.557-05:00I0.204
```

```
Status
```

Testing Network Reachability

3.6 Preparing for Circuit-Level Loopback Tests

```
UID      = 535AD8E0-F037-11C9-B60F-08002B16A872
Communication Port = xna0
Hardware Address   = 08-00-2b-16-a8-72
State             = On
MAC Address       = aa-00-04-00-50-30
Receive Mode      = Normal
```

3.7 Running Circuit-Level Loopback Tests

Use the NCL command `loop mop circuit circuit-id [parameter]` or `loop mop client client-id` to start a circuit-level loopback test.

Typically, you specify a client entity unless you need to test communication with a system that has no corresponding client entity. The circuit-level loopback command parameters are the same for both commands.

If you specify a LAN circuit, specify the address for the target communications hardware. For example, you enter:

```
ncl>loop mop circuit circuit-1 address -
_ncl>AA-00-04-00-79-34
```

If you specify a synchronous or asynchronous circuit (for example, HDLC or DDCMP) you do not need to specify the address.

3.7.1 Circuit-Level Loopback Command Parameters

You can specify any of the following parameters:

Parameter	Description								
format	Specifies the type of binary information used for the test. This is specified as a pair of hexadecimal digits such as <code>format=FF</code> . The hexadecimal value <code>55</code> , a combination of ones and zeros, is the default.								
count	Specifies the number of data blocks to be sent during the test. It is a number from 1 (default) through 65,535.								
length	Specifies the length (in bytes) of each block to be looped. This value must be a decimal integer in the range of 1 through <i>n</i> , where <i>n</i> is determined by the circuit and buffer sizes available on the local and remote systems. On the Ethernet, the allowable length is from 1 byte to the maximum length of the data pattern, which varies according to the level of assistance. The default is 40 bytes.								
	<table border="1"><thead><tr><th>Level of Assistance</th><th>Maximum Length</th></tr></thead><tbody><tr><td>No assistance</td><td>1486 bytes</td></tr><tr><td>Transmit or receive assistance</td><td>1478 bytes</td></tr><tr><td>Full assistance</td><td>1470 bytes</td></tr></tbody></table>	Level of Assistance	Maximum Length	No assistance	1486 bytes	Transmit or receive assistance	1478 bytes	Full assistance	1470 bytes
Level of Assistance	Maximum Length								
No assistance	1486 bytes								
Transmit or receive assistance	1478 bytes								
Full assistance	1470 bytes								
assistant address	Specifies the address of the system to be used as an assistant node. An assistant node is a remote system that helps you interrogate another remote node.								
assistant system	Specifies the <code>node-id</code> of the system to be used as an assistant node. Use this only for LANs.								
assistance type	Specifies the level of assistance you want to use (see Section 3.8.4.)								

3.7.2 Example of Circuit-Level Loopback Test

In this test, the software attempts to send 10 messages through the circuit called circuit-1.

```
ncl> loop mop circuit circuit-1 address aa-00-03-00-ff-08, count 10
```

3.8 Running Circuit-Level Loopback Tests with Assistance

DECnet supports the use of an assistant node to aid you in interrogating a remote node. You can use the assistance feature for LAN circuits only.

3.8.1 When to Use Assistance

You might choose one form of assistance over another for the following reasons:

- If the target node to which you want to transmit is not receiving messages from your node, you can request assistance in transmitting messages to it.
- If your node is able to transmit messages to the target node but unable to receive messages from it, you can send a message directly to the target node and request the assistant's aid in receiving a message back.
- If you encounter difficulties in both sending and receiving messages, you can request the assistant's aid for both operations.

3.8.2 Using Assistance for Fault Isolation

Running the circuit-level loopback tests with assistance in the following order can help you isolate connection problems:

1. Run a direct loopback test (with no assistance). If this test succeeds, the target system is reachable.
2. If the direct loopback test fails, use full assistance. If this test succeeds, the target system is reachable. The local system or the LAN could be the cause of your problem.
3. If the loopback test with full assistance fails, run loopback tests with transmit or receive assistance to determine if the problem occurs during transmittal or receipt of data.

3.8.3 Starting a Circuit-Level Loopback Test with Assistance

Use one of the following NCL commands to start a circuit-level loopback test with assistance:

```
ncl> loop mop circuit circuit-id address address -  
_ncl> assistance type [assistance type]
```

If you already defined a MOP client with circuit and address attributes, omit the circuit-id and address parameters and just identify the client as follows:

```
ncl> loop mop client client-name
```

If no MOP client is defined:

```
ncl> loop mop circuit circuit-id address address, -  
_ncl> assistance type [assistance type]
```

Testing Network Reachability

3.8 Running Circuit-Level Loopback Tests with Assistance

3.8.4 Assistance Parameters

When you specify either the assistant system or assistant address parameter without an assistance type, you receive full assistance by default. The following table describes the assistance type values:

Assistance Type Value	Description
assistance type none	No assistance is used.
assistance type full	This assistance type aids in transmitting loop messages to and receiving messages from a remote node (default value).
assistance type receive	This assistance type aids in receiving loop messages from a remote node.
assistance type transmit	This assistance type aids in transmitting loop messages to a remote node.

Example of Assistant Address Command

In this example, you request the node described by the LAN physical address AA-00-04-00-15-04 to assist you in testing the node described by the LAN physical address AA-00-04-00-18-04. Because assistant address is specified without the assistant type parameter, full assistance is given.

```
ncl>loop mop circuit circuit-1 address aa-00-04-00-18-04, -  
_ncl>assistant address aa-00-04-00-15-04
```

Example of Assistant System Command

In this example, you request node THRUSH to assist in testing node LOON by transmitting the loopback data to node LOON. THRUSH must already be defined in the MOP client database, with a value for its circuit and address.

```
ncl>loop mop client loon, assistant system -  
_ncl>thrush, assistant type transmit
```

3.8.5 Example of Circuit-Level Loopback Test with Full Assistance

Figure 3-4 illustrates a loopback test between the circuit for Node1 and Node3, with Node2 providing assistance. The NCL command is:

```
ncl>loop mop client Node3, assistant system Node2
```

Testing Network Reachability

3.8 Running Circuit-Level Loopback Tests with Assistance

Figure 3-4 Circuit-Level Loopback Test with Full Assistance

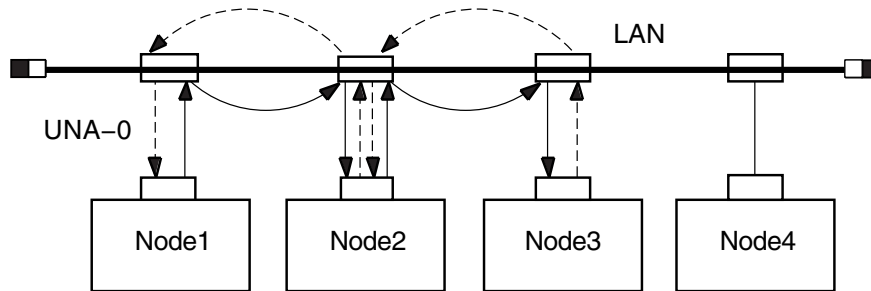

Legend:

← Shows data being looped to destination node

←--- Shows data being looped back to source node

LKG-0273-96R

3.8.6 Example of Circuit-Level Loopback Test with Transmit Assistance

Figure 3-5 illustrates a loopback test between Node1 and Node3, with Node2 providing transmit assistance. The NCL command is:

```
ncl> loop mop client Node3, assistant system Node2, -  
_ncl> assistance type transmit
```

Figure 3-5 Circuit-Level Loopback Test with Transmit Assistance

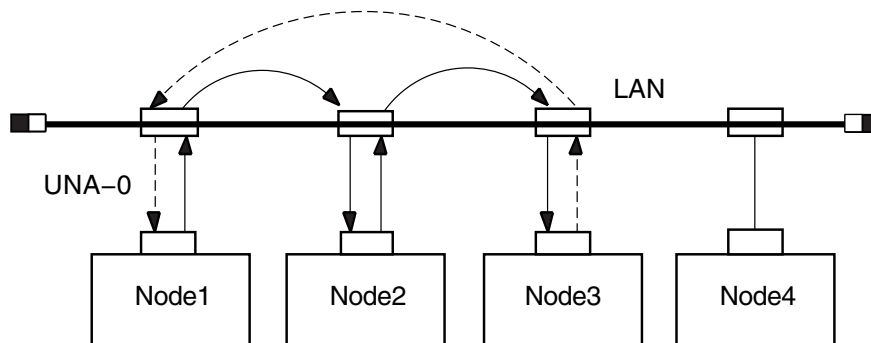

Legend:

← Shows data being looped to destination node

←--- Shows data being looped back to source node

LKG-0275-96R

3.8.7 Example of Circuit-Level Loopback Test with Receive Assistance

Figure 3-6 illustrates a loopback test between Node1 and Node3, with Node2 providing receive assistance. The NCL command is:

Testing Network Reachability

3.8 Running Circuit-Level Loopback Tests with Assistance

```
ncl>loop mop client Node3, assistant system Node2 -
_ncl>assistance type receive
```

Figure 3-6 Circuit-Level Loopback Test with Receive Assistance

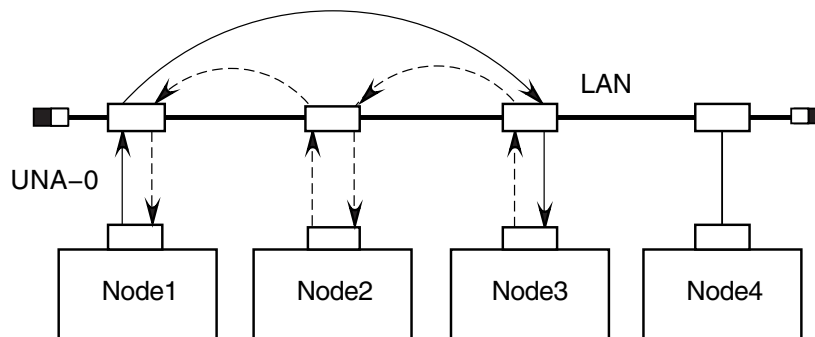

Legend:

- ← Shows data being looped to destination node
- ←--- Shows data being looped back to source node

LKG-0274-96R

3.9 Running LAN Loopback Tests with LLC Messages

This test allows you to perform LAN loopback tests that use IEEE 802.3 logical link control (LLC) test messages.

3.9.1 Starting the LAN Loopback Test

Do the following to start a LAN loopback test:

Step	Action
1	Make sure the circuit you want to test has the Test Requester function enabled.
2	Enter one of the following NCL commands: <pre>ncl>test mop circuit <i>circuit-id</i> address - _ncl>lan-address [<i>parameter</i>] ncl>test mop client <i>client-name</i> [<i>parameter</i>]</pre> Typically, you specify a client entity, unless you need to test communication with a system that has no corresponding client entity. The LAN loopback test command parameters are the same for both commands.

3.9.2 LAN Loopback Test Command Parameters

The following table describes the test command parameters for the LAN loopback test:

Testing Network Reachability

3.9 Running LAN Loopback Tests with LLC Messages

Parameter	Description
count <i>count</i>	Specifies the number of messages you want to loop. The default is 1. If the test fails, NCL displays the number of messages that successfully looped.
length <i>length</i>	Specifies the length of the data part of each test message. The maximum and minimum permitted values depend on the particular data link that you use. The default is 40.
format <i>format</i>	Specifies the value of each byte in the test data message. The hexadecimal value 55, which is a pattern of alternating ones and zeros, is the default.
sap <i>sap</i>	Specifies the service access point on the target system to which the test message is sent as 2 hexadecimal digits. The default is 00.

3.9.3 Determining Logical Link Control Types on a Remote Node

You can use the NCL command `query` to determine the logical link control (LLC) types that a remote system supports. The query command sends an IEEE 802.2 LLC XID command to a remote system and receives an XID response in return. The circuit must have the Query Requester function enabled before you can use the query command.

You can apply the `query` command to a circuit or client entity. Typically, you use a client entity, unless you need to query a system that has no corresponding client entity. You can use the same attributes for either a client or a circuit. For example, you can use either of the following commands:

```
ncl>query mop client client-name SAP sap
```

```
ncl>query mop circuit circuit-id SAP sap
```

In both commands, *sap* is the service access point on the target node, specified as 2 hexadecimal digits, to which the XID message is sent. The default is 00.

3.10 Running dts/dtr Tests

The `dtr` program functions as a slave to `dts` and exists as defined object 63 at the remote node. The `dts` program initiates each test by issuing a connect request to `dtr`. The `dts` program passes parameter information pertinent to the type of test requested to `dtr` in the optional data of the connection request. You can use the `dts` user interface to customize the test to be performed by issuing commands with options.

3.10.1 Starting dts/dtr Tests

Do the following to start `dts/dtr` tests:

Step	Action
1	Be sure that all of the DECnet protocol layers (Session Control, Transport, Routing, and Data Link) are in the on state.

Testing Network Reachability

3.10 Running dts/dtr Tests

Step	Action				
2	Enter one of the following commands: <table border="1"><thead><tr><th>OpenVMS Systems:</th><th>Digital UNIX Systems:</th></tr></thead><tbody><tr><td>\$ run sys\$system:dtsend</td><td>% dts</td></tr></tbody></table> The system responds with a message and a prompt similar to the following: <pre>DTS initiated on Mon Feb 26 13:06:22 1994 (DECnet/OSI for Digital UNIX) DTS></pre>	OpenVMS Systems:	Digital UNIX Systems:	\$ run sys\$system:dtsend	% dts
OpenVMS Systems:	Digital UNIX Systems:				
\$ run sys\$system:dtsend	% dts				
3	Enter <code>dts</code> commands at the command prompt.				
4	To end testing, type <code>exit</code> in response to the <code>dts</code> prompt. The <code>dts</code> program displays a termination message on your screen when it exits, and the system prompt reappears.				

You can also enter `dts` commands with a `dts` command file (see Section 3.10.4). You can press the up arrow key to recall previously entered commands.

3.10.2 dts Command Syntax

Use the following format to enter `dts` commands:

```
test [qualifiers][test-specific-qualifiers]
```

The following table describes the command components.

Component	Description								
<code>test</code>	Specifies the type of test, which must be one of the following: <table><tbody><tr><td><code>connect</code></td><td>Connect test</td></tr><tr><td><code>data</code></td><td>Data test</td></tr><tr><td><code>disconnect</code></td><td>Disconnect test</td></tr><tr><td><code>interrupt</code></td><td>Interrupt test</td></tr></tbody></table>	<code>connect</code>	Connect test	<code>data</code>	Data test	<code>disconnect</code>	Disconnect test	<code>interrupt</code>	Interrupt test
<code>connect</code>	Connect test								
<code>data</code>	Data test								
<code>disconnect</code>	Disconnect test								
<code>interrupt</code>	Interrupt test								

Testing Network Reachability

3.10 Running dts/dtr Tests

Component	Description
<i>qualifiers</i>	<p>Specifies any number of the following optional qualifiers. These qualifiers remain in effect for all applicable tests until you change them or exit from <code>dts</code>. A slash (/) must precede each qualifier.</p> <p style="margin-left: 40px;"><i>/nodename =node-id</i> The name or address of the DECnet node on which you want <code>dtr</code> to run. You must specify it once and then the default will be that node name. If you run <code>dtr</code> on a remote node, you must run it on a default nonprivileged account (guest account), because you cannot specify access-control information with this qualifier. The <code>node-id</code> can be 0, a Phase IV address or on a UPROD system, a DECnet-Plus NSAP address. If any part is different from the <code>dts</code> sender node default, it should be specified.</p> <p style="margin-left: 40px;"><i>/print or /noprint</i> (default) Tells <code>dts</code> whether to print (log) test results.</p> <p style="margin-left: 40px;"><i>/statistics or /nostatistics</i> (default) Tells <code>dts</code> whether to print statistics on data and interrupt tests.</p> <p style="margin-left: 40px;"><i>/display or /nodisplay</i> (default) Tells <code>dts</code> whether to print the data and interrupt messages transmitted to <code>dtr</code> during data and interrupt tests.</p> <p style="margin-left: 40px;"><i>/speed =number</i> Specifies the test line speed in bits per second (default=0); <code>dts</code> uses this data for reporting statistics.</p> <p style="margin-left: 40px;"><i>/transport = transport name</i> <i>For Digital UNIX systems only.</i> Specifies the transport protocol to use, where the transport name is either <code>dna_nsp</code> or <code>dna_tp4</code>.</p>
<i>test-specific-qualifiers</i>	<p>Specifies any number of test-specific qualifiers, as defined in the sections that describe each test. Test-specific qualifiers apply to the current test only.</p>

3.10.3 General Command Syntax Conventions

The `dts` command syntax uses the following conventions:

- All test names and qualifiers can be abbreviated to the first three or more unique characters.
- The default values for a qualifier remain in effect until a different value is specified. The specified value then becomes the new default for all following tests until that value is changed.

3.10.4 Examples of Using dts/dtr Test Command Procedures

The following OpenVMS example shows how to instruct `dts` to process the commands contained in the file `dts.com` and to redirect the output to the file `dts.log`.

```
$ run sys$system:dtsend/output=dts.log
```

The following Digital UNIX example shows how to instruct `dts` to process the commands contained in the file `dtsscript` and to redirect the output to logging file `dts.log`.

Testing Network Reachability

3.11 Running dts/dtr Connect Tests

Qualifier	Description
	reject Connect reject test
/return= <i>type</i> or noreturn	Specifies the type of data returned by dtr. The <i>type</i> can be:
	standard Standard user data
	received Received user data
	/noreturn No optional user data returned (default)
/transport=dna_nsp or dna_tp4	<i>For Digital UNIX systems only.</i> Defaults to the first available protocol tower.

3.11.2 Example of dts/dtr Connect Test Command

This command invokes a connect accept test (by default) with remote node MONTRL.

```
dts>connect/nodename=montrl/return=received
```

The dtr program returns received user data as part of the test.

3.12 Running dts/dtr Data Tests

You can perform the following data tests:

Test	Description
Sink test	The dtr program ignores all data received. No sequence or content validation is performed.
Sequence test	Data messages transmitted by dts to dtr include a 4-byte sequence number. If a message is received out of sequence, dtr aborts the logical link and the test.
Pattern test	Data messages transmitted to dtr have both a sequence number and a standard data pattern. If neither the sequence number nor the received data matches the expected data, dtr aborts the logical link and the test.
Echo test	Data messages received by dtr are transmitted back to dts, which checks the sequence number and data for the returned messages. If either is incorrect, dts aborts the link and the test.

3.12.1 dts/dtr Data Test Command Syntax

Invoke dts and use this command to start a data test:

```
data[qualifiers] [test-specific-qualifiers]
```

On OpenVMS systems, the value of the node qualifier must be a minimum of 4 characters.

The following table describes the *test-specific-qualifiers*.

Qualifier	Description
/type= <i>subtest</i>	Specifies the type of test, where <i>subtest</i> can be:

Testing Network Reachability

3.12 Running dts/dtr Data Tests

Qualifier	Description
	<p>sink Sink test (default)</p> <p>sequence Sequence test</p> <p>pattern Pattern test</p> <p>echo Echo test</p>
/size= <i>number</i>	<p>Specifies data message length in bytes.</p> <p>On OpenVMS systems, <i>number</i> is a value from 5 to 4,095.</p> <p>On Digital UNIX systems, <i>number</i> is a value from 1 to 2,048 (default=128).</p> <p>The minimum value for <i>number</i> on a sequence test is 4 and on a pattern test is 5. A size of 4,095 returns an error message on an echo test.</p>
/test-duration	<p>Specifies duration of the test in one of the following formats:</p> <p>seconds=<i>number</i> Range: 1 to 60 1 to 59 on OpenVMS</p> <p>minutes=<i>number</i> Range: 1 to 60 1 to 59 on OpenVMS</p> <p>hours=<i>number</i> Range: 1 to 24</p> <p>On OpenVMS systems, the default is seconds=30.</p> <p>On Digital UNIX systems, the default is seconds=15.</p>
/flow= <i>type</i> or /noflow (default)	<p>Specifies type of flow control, if any, where <i>type</i> can be:</p> <p>segment Segment flow control</p> <p>message Message flow control (default, if /flow is specified)</p> <p>If dtr is running on OpenVMS software, it must use the system default.</p>
/rqueue= <i>number</i> or /squeue= <i>number</i>	<p><i>For Digital UNIX systems only.</i> Specifies the number of pending receives for dtr to maintain, where <i>number</i> is a value from 1 to 16 (default = 1). If the remote system is a DECnet-Plus node, this parameter is ignored.</p>
/nak= <i>number</i> or /noack	<p><i>For Digital UNIX systems only.</i> Specifies the number of segments between negative acknowledgments (NAKs). If the remote system is a DECnet-Plus node, this parameter is ignored.</p>
/back= <i>number</i> or /noback	<p><i>For Digital UNIX systems only.</i> Specifies the number of segments before back pressuring. If the remote system is a DECnet-Plus node, this parameter is ignored.</p>
/transport=dna_nsp or dna_tp4	<p><i>For Digital UNIX systems only.</i> Defaults to the first available protocol tower.</p>

3.12.2 Example of dts/dtr Data Test Command

This command invokes the data test with the sink subtest (by default). The dts program sends messages to dtr on node JONES (by default from a previous command). The message size is 512 bytes, and the test lasts 30 seconds. The transport protocol is printed only when you specify a transport.

Testing Network Reachability

3.12 Running dts/dtr Data Tests

```
dts>data/size=512/seconds=30
DTS --I-- Test started at 11:23:30
DTS --I-- Test finished at 11:24:00

Test parameters:
  Target node      "jones"
  Test duration (sec) 30
  Message size (bytes) 512

Summary statistics:
  Total messages SENT      48
  Total bytes SENT        24576
  Messages per second     1.60
  Bytes per second        819.20
  Line throughput (baud)  6553
```

3.13 Running dts/dtr Disconnect Tests

You can perform the following disconnect tests:

Test	Description
Disconnect without data	The <code>dtr</code> node sends a disconnect message that does not contain user data to the <code>dts</code> node.
Abort without user data	The <code>dtr</code> node sends an abort message that does not contain user data to the <code>dts</code> node.
Disconnect with standard user data	The <code>dtr</code> node sends a disconnect message that contains a standard string of optional data to the <code>dts</code> node. If the transport is NSP, this is 16 bytes, and if the transport is TP4, it is 32 bytes.
Abort with standard user data	The <code>dtr</code> node sends an abort message that contains a standard string of optional data to the <code>dts</code> node. If the transport is NSP, this is 16 bytes, and if the transport is TP4, it is 32 bytes.
Disconnect with received connect user data used as disconnect user data	The <code>dts</code> node sends a message containing optional user data to the <code>dtr</code> node. The <code>dtr</code> node returns a disconnect message containing the same optional data to the <code>dts</code> node.
Abort with received connect user data used as abort user data	The <code>dts</code> node sends a message containing optional user data to the <code>dtr</code> node. The <code>dtr</code> node returns an abort message containing the same optional data to the <code>dts</code> node.

3.13.1 dts/dtr Disconnect Test Command Syntax

Invoke `dts` and use the following command to start a disconnect test:

```
disconnect [qualifiers] [test-specific-qualifiers]
```

The following table describes the *test-specific-qualifiers*.

Testing Network Reachability

3.13 Running dts/dtr Disconnect Tests

Qualifier	Description
<code>type=subtest</code>	Specifies the type of test, where <i>subtest</i> can be: synchronous Synchronous disconnect test for Digital UNIX systems only abort Disconnect abort test (default)
<code>/return=type</code> or <code>/noreturn</code>	Specifies the type of data returned by dtr. The type can be: standard Standard user data received Received user data The <code>/noreturn</code> qualifier causes no optional user data to be returned (default).

3.13.2 Example of dts/dtr Disconnect Test Command

This command invokes a synchronous disconnect test with remote node PARIS.

```
dts>disconnect/nodename=paris/type=synchronous
```

The dtr program will not return any optional user data.

3.14 Running dts/dtr Interrupt Tests

You can perform the following interrupt tests:

Test	Description
Sink test	The dtr program ignores all interrupt data received. No sequence or content validation is performed.
Sequence test	Interrupt messages transmitted by dts to dtr contain a 4-byte sequence number. If a message is received out of sequence, dtr aborts the logical link and the test.
Pattern test	Interrupt messages transmitted to dtr have both a sequence number and a standard data pattern. If neither the sequence number nor the data pattern received matches the expected data, dtr aborts the logical link and the test.
Echo test	Interrupt messages received by dtr are transmitted back to dts, which checks the sequence number and data of the returned messages. If either is incorrect, dts aborts the link and the test.

3.14.1 Interrupt Test Command Syntax

Invoke dts and use this command to start an interrupt test:

```
interrupt[qualifiers] [test-specific-qualifiers]
```

The following table describes the *test-specific-qualifiers*:

Qualifier	Description
<code>/type=subtest</code>	Specifies the type of test, where <i>subtest</i> can be: sink Sink test (default) sequence Sequence test

Solving Problems Using DECnet Over TCP/IP

This chapter describes solving problems using DECnet over TCP/IP.

Topics In This Chapter

The topics in this chapter are:

- Local IP Address Displays As 0.0.0.0 (Section 4.1)
- Troubleshooting (Section 4.2)

Solving Problems Using DECnet Over TCP/IP

4.1 Local IP Address Displays As 0.0.0.0

4.1 Local IP Address Displays As 0.0.0.0

Some TCP/IP products do not support a "read local address" function through the PWIP (PATHWORKS Internet Protocol) driver interface. As a workaround, OSI transport tells Session Control/Node Agent that the node local IP address is 0.0.0.0.

Therefore, the following address is correct:

```
NCL> SHOW NODE 0 address
```

```
Address =
{
  (
    [ DNA_CMIP-MICE ] ,
    [ DNA_SessionControlV3 , number = 19 ] ,
    [ DNA_OSITransportV1 , 'DECO'H ] ,
    [ DNA_OSInetwork , 49::00-33:AA-00-04-00-FF-FF:21 ]
  ) ,
  (
    [ DNA_CMIP-MICE ] ,
    [ DNA_SessionControlV2 , number = 19 ] ,
    [ DNA_OSITransportV1 , 'DECO'H ] ,
    [ DNA_IP , 0.0.0.0 ]
  ) ,
  (
    [ DNA_CMIP-MICE ] ,
    [ DNA_SessionControlV3 , number = 19 ] ,
    [ DNA_NSP ] ,
    [ DNA_OSInetwork , 49::00-33:AA-00-04-00-FF-FF:20 ]
  )
}
```

4.2 Troubleshooting

If you have problems getting DECnet over TCP/IP to start up properly, check the following:

1. Verify that you have an OSI transport template with network service attribute defined as RFC 1006.

Issue the command:

```
NCL> SHOW OSI TRANSPORT TEMPLATE * WITH NETWORK SERVICE = rfc1006
```

If you do not have a template defined, then you must execute NET\$CONFIGURE Option 4 and replace your OSI transport startup script.

2. Verify that you have started TCP/IP, and that your product supports the PWIP interface. If you are using Digital TCP/IP Services for OpenVMS, be sure that you have executed the following command procedure:

```
SYS$STARTUP:UCX$PWIP_STARTUP.COM
```

3. Verify that the PWIP interface is properly registered. Using the management tool of the TCP/IP product installed, verify that the RFC 1006 listener ports defined in OSI transport are known by TCP/IP.

If you are running Digital TCP/IP Services for OpenVMS, use the following command:

Solving Problems Using DECnet Over TCP/IP

4.2 Troubleshooting

```
$ UCX SHOW DEVICE
```

Device_socket	Type	Port		Service	Remote
		Local	Remote		Host
bg3	STREAM	23	0	TALENT	0.0.0.0
bg4	DGRAM	520	0		0.0.0.0
bg7	STREAM	399	0		0.0.0.0
bg9	STREAM	102	0		0.0.0.0

In this case, we are looking for the two listen ports 399 and 102.

If IP addresses work and IP names do not, use your TCP/IP management tool to verify that your BIND server knows about the name.

Solving DECnet-Plus Application Problems

This chapter describes how to isolate and correct common DECnet-Plus application problems.

Definition

In this chapter, the term **DECnet-Plus applications** refers to FTAM, Virtual Terminal (VT), and any application that uses the OSI Applications Kernel (OSAK) application programming interface (API).

This manual does not discuss other applications considered to be OSI applications, such as X.400 products.

Topics in This Chapter

The topics in this chapter are:

- Underlying Components for DECnet-Plus Applications (OpenVMS Only) (Section 5.1)
- Underlying Components for DECnet/OSI Applications (Digital UNIX Only) (Section 5.2)
- Symptoms of DECnet-Plus Application Problems (Section 5.3)
- Isolating DECnet-Plus Application Faults (Section 5.4)
- Using Event Logging and Log Files (Section 5.5)
- Isolating Faults Using Management Tools (OpenVMS Only) (Section 5.6)
- Tracing Overview (Section 5.7)
- Tracing Outbound FTAM and Virtual Terminal Connections (Section 5.8)
- Tracing Inbound FTAM and Virtual Terminal Connections (Section 5.9)
- Reading Trace Files (Section 5.10)
- Correcting FTAM Application Problems (Section 5.11)
- Correcting FTAM File-Handling Problems (Section 5.12)

Solving DECnet-Plus Application Problems

)

- Correcting General FTAM Connection Problems (Section 5.13)
- Correcting FTAM and Virtual Terminal Connection Problems (Digital UNIX Only) (Section 5.14)
- Correcting FTAM and Virtual Terminal Responder Problems (OpenVMS Only) (Section 5.15)
- Correcting FTAM and Virtual Terminal Responder Problems (Digital UNIX Only) (Section 5.16)
- Correcting FTAM Environment Problems (OpenVMS Only) (Section 5.17)
- Correcting Target SAP Connection Problems (Section 5.18)
- Correcting Problems with Applications Using OSAK (Section 5.19)

5.1 Underlying Components for DECnet-Plus Applications (OpenVMS Only)

Figure 5–1 shows the underlying DECnet-Plus components that DECnet-Plus applications on OpenVMS systems use. Use this information as a guide during fault isolation.

Solving DECnet-Plus Application Problems

5.1 Underlying Components for DECnet-Plus Applications (OpenVMS Only)

Figure 5-1 Underlying DECnet-Plus Components (OpenVMS)

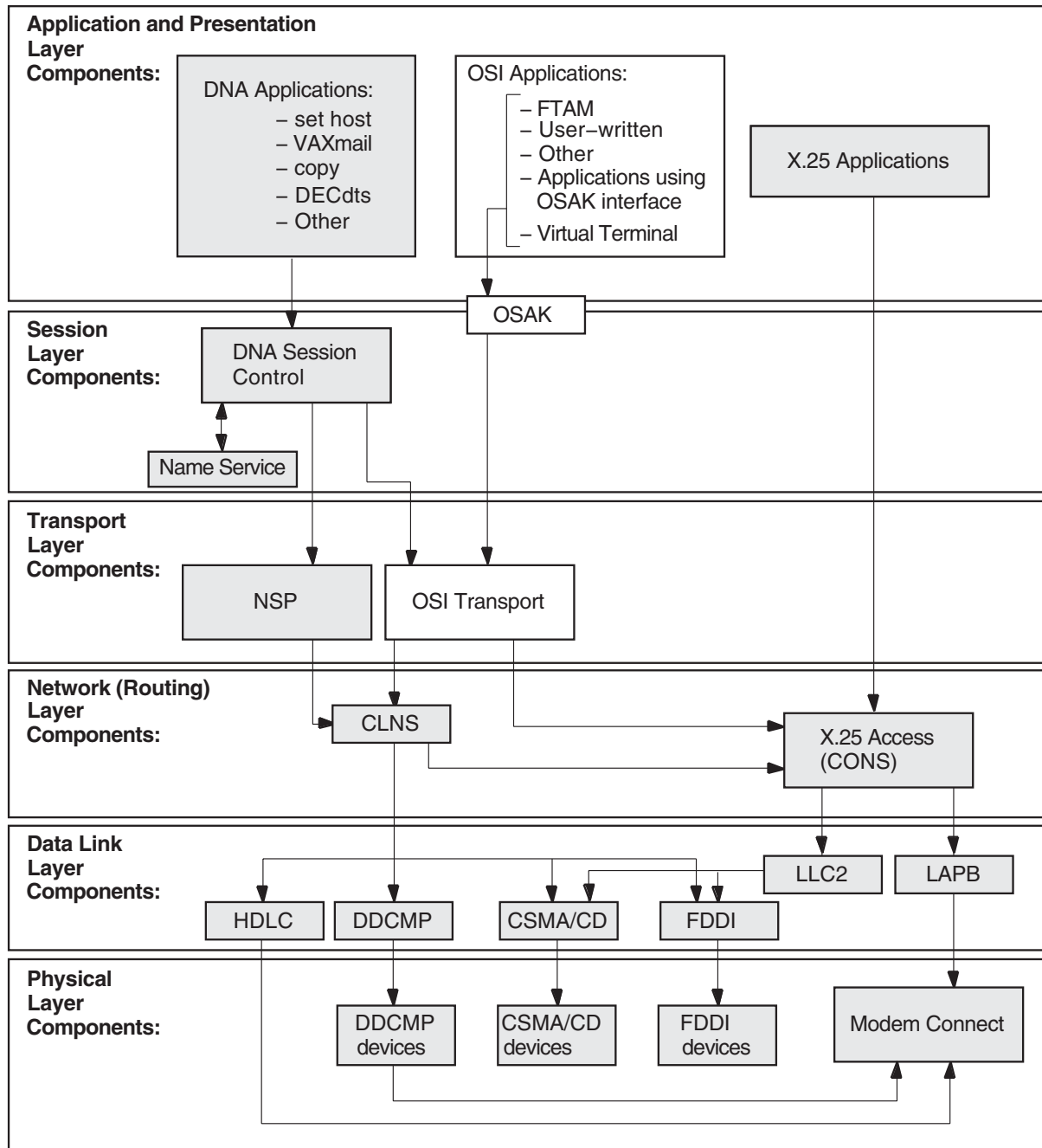

LKG-09681.96R

Solving DECnet-Plus Application Problems

5.2 Underlying Components for DECnet/OSI Applications Digital UNIX Only

5.2 Underlying Components for DECnet/OSI Applications Digital UNIX Only

Figure 5–2 shows the underlying DECnet/OSI components used by DECnet/OSI applications on Digital UNIX systems. Use this information as a guide during fault isolation.

Solving DECnet-Plus Application Problems

5.2 Underlying Components for DECnet/OSI Applications Digital UNIX Only

Figure 5-2 Underlying DECnet/OSI Components (Digital UNIX)

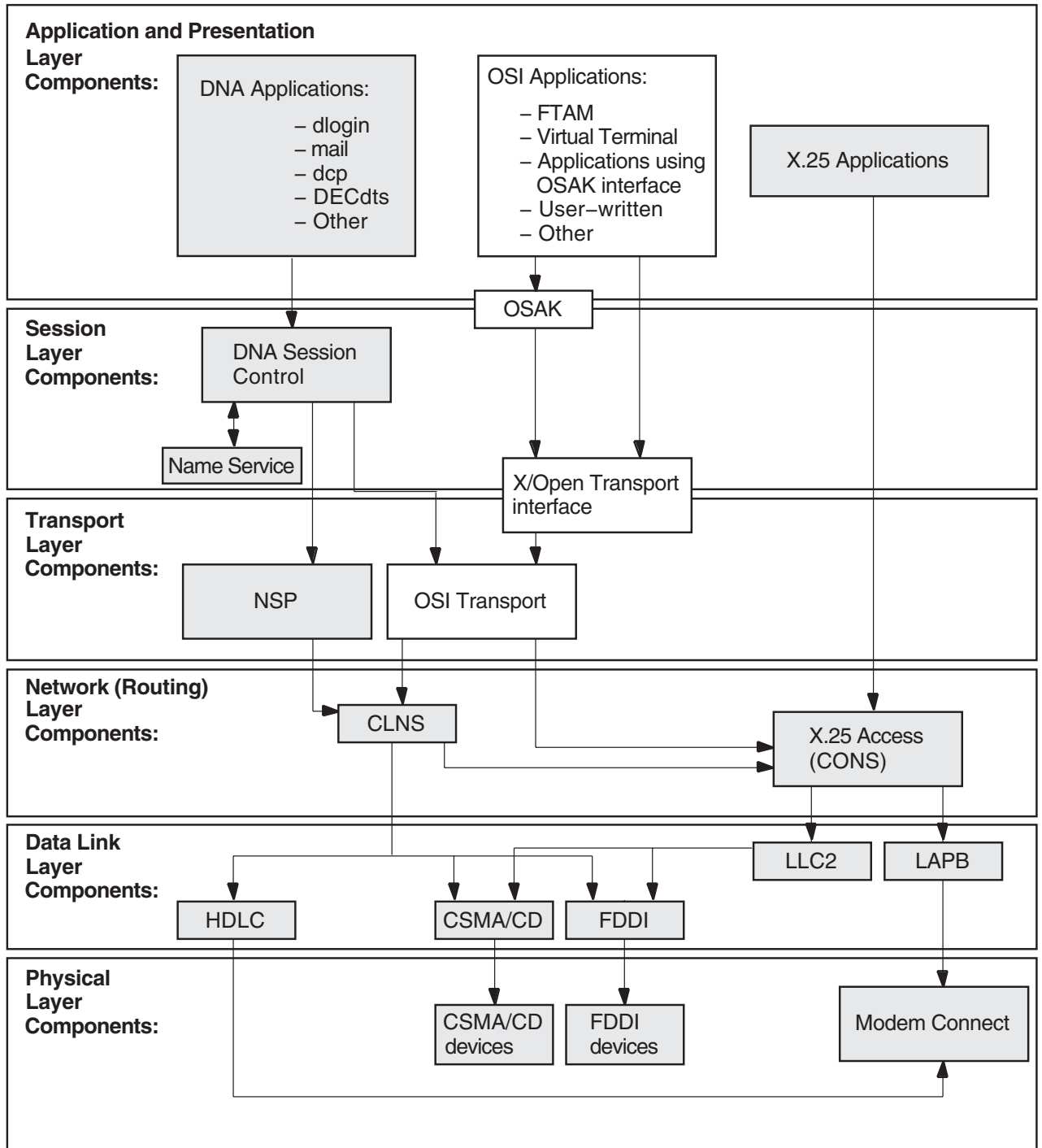

LKG-09682-96R

Solving DECnet-Plus Application Problems

5.3 Symptoms of DECnet-Plus Application Problems

5.3 Symptoms of DECnet-Plus Application Problems

The following tables show the symptoms of possible DECnet-Plus application problems on both OpenVMS and Digital UNIX systems, on OpenVMS systems only, and on Digital UNIX systems only.

5.3.1 Problem Symptoms for All Systems

Table 5–1 describes DECnet-Plus application problems that can occur on either OpenVMS or Digital UNIX systems.

Table 5–1 Symptoms and Problems for All Systems

Symptom	Possible Problem	See:
Connection attempts fail.	Reasons for failure include: <ul style="list-style-type: none"> • User name, password, or both used in commands are incorrect. • A responder is not listening on the remote address that the initiator specified. • Errors exist in the local database file. 	Section 5.11 or 5.13.
An FTAM or Virtual Terminal responder fails.	Reasons for failure include: <ul style="list-style-type: none"> • The requested transport provider is not available. • The command syntax used to start an operation was entered incorrectly. • An error exists in the format specified in the command line or the local database file. • Multiple OSI applications are using the same transport selector. 	Section 5.11, 5.14.1, or 5.16.
An FTAM file does not have the expected attributes.	Requested format is not supported and must be converted.	Section 5.12.2.
A user-written OSI application terminates unexpectedly.	Reasons for failure include: <ul style="list-style-type: none"> • Protocol • Network • Loss of network connection • Remote entry aborted connect 	Section 5.19 or FTAM API documentation.
A problem with a user-written application affects the OSAK software.	There is a coding error in the application or in the way the application uses the OSAK application programming interface.	Section 5.19 or OSAK documentation.

Solving DECnet-Plus Application Problems

5.3 Symptoms of DECnet-Plus Application Problems

5.3.2 Problem Symptoms for OpenVMS Systems Only

Table 5–2 describes DECnet-Plus application problems that can occur on OpenVMS systems only.

Table 5–2 Symptoms and Problems for OpenVMS

Symptom	Possible Problem	See:
Connection attempts fail.	Reasons for failure include: <ul style="list-style-type: none"> • OpenVMS environment is not set up correctly. • FTAM application is not set up correctly. • A responder is not listening on the remote address that the initiator specified. • A remote entity sent a refuse PDU. 	Section 5.13, 5.17, or 5.15.
An FTAM responder fails.	There is a problem with the OSAK\$SERVER_V3.	Section 5.13.
A VT responder terminates unexpectedly.	Resources are exhausted.	Section 5.15.
A VT responder will not start.	Another responder is already running.	Section 5.15.

5.3.3 Problem Symptoms for Digital UNIX Systems Only

Table 5–3 describes DECnet/OSI application problems that can occur on Digital UNIX systems only.

Table 5–3 Symptoms and Problems for Digital UNIX

Symptom	Possible Problem	See:
Connection attempts fail.	Reasons for failure include: <ul style="list-style-type: none"> • A listener and responder need to be running on the same system (for example, for a gateway node). • A listener/responder is not listening on the remote address that the initiator specified. • Syntax for alias entry in the local database file /etc/isoapplications is wrong. • An incorrect transport template was specified in the local database file /etc/isoapplications. • A remote entity sent a refuse PDU. 	Section 5.14.
An FTAM or VT responder fails.	There is a problem with the ftam_listener or vt_listener process.	Section 5.16.

Solving DECnet-Plus Application Problems

5.4 Isolating DECnet-Plus Application Faults

5.4 Isolating DECnet-Plus Application Faults

Before trying any correction procedures, confirm that you have a DECnet-Plus application problem. Use an application other than the one that failed, such as `dlogin` or `set host`, to try to establish a connection to the remote node.

If you can establish a connection, a problem with the failed application is likely the cause; use the trace utilities for further fault isolation. If you cannot establish a connection, the problem is probably not application-specific; use the network reachability tests described in Chapter 3, or check the underlying components that the application uses.

5.4.1 Tools to Use

Table 5–4 shows the tools you can use to isolate DECnet-Plus application faults.

Table 5–4 Tools for Isolating Application Faults

For Problems with:	Use:	And See:
Any DECnet-Plus application	Error messages: <ul style="list-style-type: none">• Check error messages displayed on the user's terminal.• Check error messages displayed on the system console.• On Digital UNIX, check the <code>/usr/adm/syslog.dated/*/daemon.log</code> file.• On OpenVMS for FTAM, check <code>osif\$responder.log</code> file located in your default login directory.	OSI application documentation and Section 5.5.
	Tracing utility, <code>ositrace</code> .	Section 5.8.
DECnet-Plus applications on OpenVMS systems	Event logging.	OSAK, FTAM and Virtual Terminal documentation.
FTAM and Virtual Terminal on OpenVMS systems	OSAK application database and <code>sys\$system:isoapplications.dat</code> file.	FTAM/VT documentation.
Applications that use OSAK software	OSAK trace utility.	OSI application documentation or the OSAK programming documentation.

5.4.2 References

Refer to your FTAM and Virtual Terminal documentation for further information about these applications. Refer to your OSAK documentation for information about applications that utilize the OSAK API.

5.5 Using Event Logging and Log Files

On OpenVMS systems, event logging and log files help you isolate FTAM and Virtual Terminal problems. After you enable logging, the system writes events to the `sys$manager:operator.log` file.

On Digital UNIX systems, FTAM and Virtual Terminal error messages appear on the operator's console. The system writes responder error messages to the `/usr/adm/syslog.dated/*/daemon.log` file. You do not need to do anything to enable error logging.

5.5.1 Enabling Network Event Logging (OpenVMS Only)

Enabling network event logging on an OpenVMS system can help you quickly identify FTAM or Virtual Terminal problems. Do the following to enable event logging of network and license events:

Step	Action
1	Enable OPER privileges with the following DCL command: <code>\$ set process/priv=oper</code>
2	Ensure that OPCOM is running. If you do not know how to do this, get help from your system manager.
3	Do one of the following: <ul style="list-style-type: none">To display subsequent errors on a dedicated terminal, enable error logging to the terminal by entering the following DCL command: <code>\$ reply/enable=(network,license)</code>Type the log file <code>sys\$manager:operator.log</code> and examine it.
4	For events at the Data Link layer, specify the event types you want. For both X.25 and IEEE 802.3 events, see your NCL reference documentation. For X.25 events only, see your OSI Transport and X.25 documentation.

5.5.2 Using the FTAM Responder Log File (OpenVMS Only)

Each FTAM responder process on an OpenVMS system creates a log file of its activity during a process. If you are trying to track the responder's operations, this log file may contain pertinent information, depending on where the problem occurs.

Normally, a responder process creates a log file in the `SYS$LOGIN` directory of the account specified by the user on the FTAM command line.

Responder Log Set Up

Ensure that your system is set up correctly to use the responder log:

Step	Action
1	Check for WORLD:READ protection on <code>osif\$responder.com</code> .
2	Check that the responder has WRITE access (for <code>osif\$responder.log</code>) into the login account's default directory.
3	If you are using an account other than the default FTAM responder account, make sure that the account has a BYTLM of more than 20,000. If not, you may experience "service provider abort" errors.

Solving DECnet-Plus Application Problems

5.6 Isolating Faults Using Management Tools (OpenVMS Only)

5.6 Isolating Faults Using Management Tools (OpenVMS Only)

You can use management tools to isolate FTAM or VT faults on OpenVMS systems. Do the following when you use management tools for this purpose:

For this Connection:	Do the Following:	To Verify:
Inbound to a given address (FTAM only)	Use NCL commands to check inbound address in OSAK application database: <code>show osak application</code>	The following values: <ul style="list-style-type: none">• Presentation selector• Session selector• Transport selector• File name of responder command file• User name• Login password of user name (if any) (you need system privileges to do this)• Account name (optional)• AP-title (optional, not verified)• AE-qualifier (optional, not verified)
Outbound to a given address	Examine <code>sys\$system:isoapplications.dat</code>	The following values: <ul style="list-style-type: none">• Alias• Presentation selector• Session selector• Transport selector• OSI transport address (NSAP, TSAP, Provider)• AP-title (optional)• AE-qualifier (optional)• Session version (optional)• All field delimiters

5.7 Tracing Overview

Tracing allows you to examine FTAM and Virtual Terminal connections to other OSI systems. The trace operation traces the protocol data units (PDUs) that the Application, ACSE, Presentation, and Session layers send or receive. Tracing is a two-step process. First, you create a binary trace file during a regular FTAM or VT connection. Then you use the `ositrace` utility to convert the binary file to a readable text file.

5.7.1 Trace Files

The `ositrace` utility formats the binary trace information. You can redirect output into a file using appropriate mechanisms. By default, the file is written to the default output device.

The `ositrace` utility creates a new file for each trace in the default directory of the process where tracing is enabled. It also creates a new version of the trace file for each new connection it traces.

5.7.2 Security Information in Tracing

For either initiator or responder traces, if a file specification contains security information, the output for an FTAM or VT Protocol Control Information (PCI) trace contains the initiator identity (which maps to a user name) and the filestore password (which maps to a login password) in plain ASCII text. Trace files containing this information should be securely stored or deleted immediately after the trace data is analyzed.

5.8 Tracing Outbound FTAM and Virtual Terminal Connections

This section describes how to trace FTAM and Virtual Terminal connections to other OSI initiator systems. The original file that the trace operation creates contains binary information. The `ositrace` utility converts the binary file to a readable text file.

For OpenVMS Systems:

```
define OSAK_TRACE ON
```

For Digital UNIX Systems:

```
setenv OSAK_TRACE on
```

The trace file is created in your current working directory with the name `init_xxxx.bin`, where `xxxx` is the time and date.

An alternate method of generating a trace for FTAM is to create the following definitions in the initiator process (OpenVMS only):

```
define osif$trace_enable FTAM_PCI, ACSE_PCI, PRESENTATION_PCI, SESSION  
define osif$trace osif$init.trace
```

This creates the file `osif$init.trace`. It contains the same information as the trace generated by setting `OSAK_TRACE` to `ON`, and you can use `ositrace` to generate a readable form.

Solving DECnet-Plus Application Problems

5.8 Tracing Outbound FTAM and Virtual Terminal Connections

5.8.1 Generating a Readable Trace File

The command syntax for starting the `ositrace` utility is:

For OpenVMS Systems:	For Digital UNIX Systems:
<code>ositrace input-file [output-file]</code>	<code>ositrace [options] input-file [output-file]</code>

The *input-file* specifies the binary trace file that is created when you define the trace logical names on OpenVMS systems or specify the `-T` option, or define the environment variables, on Digital UNIX systems.

The *output-file* redirects the output to the specified file instead of displaying the output on the default device or file.

On OpenVMS, define `OSITRACE`:

```
$ OSITRACE== $OSITRACE
```

5.8.2 `ositrace` Command Options (Digital UNIX Only)

The trace records of all the components are processed by default if you do not specify one or more of the command options. Table 5–5 describes the `ositrace` command options on Digital UNIX systems.

Table 5–5 `ositrace` Command Options

Option	Description
<code>-h</code>	Displays a brief help message that includes usage syntax and valid command options.
<code>-F</code>	Displays trace records only for the FTAM components. The trace monitors protocol control information (PCI) and file-access data unit (FADU) components. An FTAM PCI trace monitors the inbound and outbound FTAM service primitives. The trace output logs PCI octets and analyzes the FTAM PCI. An FTAM FADU trace monitors the inbound and outbound file structure data. The trace is formatted into two columns: the left column logs the octets of data and the right column logs the text equivalents of the octets.
<code>-V</code>	Displays trace records only for the Virtual Terminal components. The trace monitors protocol control information (PCI). A Virtual Terminal PCI trace monitors the inbound and outbound Virtual Terminal service primitives. The trace output logs PCI octets and analyzes the Virtual Terminal PCI. The trace is formatted into two columns: the right column logs the octets of data and the left column logs the text equivalents of the octets.
<code>-A</code>	Displays trace records only for the ACSE layer. The trace monitors the inbound and outbound ACSE service primitives. The trace output logs PCI octets and analyzes the ACSE PCI.
<code>-P</code>	Displays trace records only for the Presentation layer. The trace monitors the inbound and outbound presentation service primitives. The trace output logs presentation PDU (PPDU) octets and analyzes the presentation PCI.
<code>-S</code>	Displays trace records only for the session layer. The trace monitors the inbound and outbound session service primitives. The trace output logs session PDU (SPDU) octets and analyzes the session PCI.
<code>-f</code>	Filters timestamps. This option causes all timestamps to appear as the string <code>xx-xx-xxxx,xx:xx:xx</code> and allows the comparison of two trace files using the <code>diff</code> command.

5.9 Tracing Inbound FTAM and Virtual Terminal Connections

This section describes how to trace FTAM and Virtual Terminal connections from other OSI systems.

5.9.1 Inbound FTAM and VT Tracing (Digital UNIX)

- Log into the root account.
- Set the environment variable OSAK_TRACE to on.

```
setenv OSAK_TRACE on
```

- Start a VT or FTAM listener.

```
vt_listener mynode-alias
```

This creates 10 resp_XXXX.bin files, where XXXX is the time and date. The default queue length is ten for the number of outstanding transport connect indications. The oldest .bin file contains the trace of the first association, the next youngest contains the second association, and so on.

- To stop the trace, kill the current listener process, and unset the OSAK_TRACE environment variable:

```
ps auxw | grep ftam
root 3380 0.0 ftam_listener mynode-alias
kill -9 3380
unsetenv OSAK_TRACE
```

5.9.2 Inbound FTAM Tracing (OpenVMS)

Edit the file sys\$system:osif\$responder.com to contain the following line:

```
$ define osak_trace on
```

The file resp_XXXX.bin is created in the default directory of the responder process, where XXXX is the time and date.

Alternatively, you can edit the file osif\$responder.com to uncomment the following lines:

```
#! DEFINE /LOG osif$trace_enable FTAM-PCI,ACSE-PCI,PRESENTATION-PCI,SESSION
#! DEFINE /LOG osif$trace osif$responder.trace
```

The next inbound connection causes an FTAM trace file called osif\$responder.trace to be created in the default login directory (SYS\$LOGIN) of the specified account.

To trace the DAP gateway, you can choose one of the following options:

1. Define osak_trace in the file sys\$system:osif\$gtwy_login.com.
2. Define osif\$trace and osif\$trace_enable in the file sys\$system:osif\$gtwy_login.com.

The trace file will be created in the default directory of the OSIF\$GTWY account.

The trace file created may then be formatted using ositrace as discussed in Section 5.8.1.

Solving DECnet-Plus Application Problems

5.9 Tracing Inbound FTAM and Virtual Terminal Connections

5.9.3 Inbound VT Tracing (OpenVMS)

- Stop the current VT responder (`SYS$STARTUP:VT_STOP.COM`).
- Copy `SYS$SYSTEM:VTPAD.EXE` to `SYS$COMMON:[SYSEXE]VT_RESPONDER.EXE`.
- Define the logical name `OSAK_TRACE` to equate to the value `ON`.

```
$ define osak_trace on
```
- Make sure your process has the following privileges:
`CMKRNL, WORLD, SYSPRV, TMPMBX, SYSNAM, DETACH, NETMBX, SYSLCK, OPER, PRMMBX`
- Issue the command:

```
RUN SYS$SYSTEM:VT_RESPONDER.EXE
```

At this point, the VT responder is executing in your process context, and eight (or the value specified by the `VT$VT_RJOBLIM` logical name) `resp_xxxx.bin` files will be created in your current directory.

As each new connection made to the VT responder terminates, a new `resp_xxxx.bin` file is created, and a previous `resp_xxx.bin` file now contains trace information. This is done in a first in, first out manner; the oldest `.bin` file contains the trace of the first association, the next youngest contains the second association, and so on.

Once you have collected all of the required trace data, use `Ctrl/C` and terminate the VT responder. Any `resp_xxxx.bin` files with a size of 0 may be deleted. `Resp_xxxx.bin` files which have non-zero sizes may be analyzed using `ositrace` (see Section 5.8.1 for more information).

The regular VT responder may now be restarted using the `SYS$STARTUP:VT_START.COM` procedure.

The VT/LAT or VT/TELNET gateways may also be traced in a similar manner by copying `VTPAD.EXE` to `VT_LAT_GTWY.EXE` or `VT_TELNET_GTWY.EXE` respectively.

The LAT/VT or TELNET/VT gateways may be traced by copying `VTPAD.EXE` to `LAT_VT_GTWY.EXE` or `TELNET_VT_GTWY.EXE` respectively. However, the trace files produced will be named `init_xxxx.bin` to reflect the fact that we are now acting as an initiator.

5.10 Reading Trace Files

Open systems transmit PCI and file data in the form of octet strings. For each component being traced, the tracing utility logs the octets of PCI, file data, or both, sent or received by that component. The trace utility transcribes the octets into a sequence of hexadecimal digits. For PCI data, the utility also translates the data into ASN.1 (abstract-syntax notation). These translations correspond to the PCI definition of the component's service primitives. PCI definitions are part of the protocol specification of each FTAM or Virtual Terminal component.

You can compare tracing output to the corresponding PCI definition, to determine whether the encoding of PCI data is correct and whether the parameter values are valid. You can also compare the actual sequences of parameters with the valid sequences defined by the protocol. For information about FTAM and VT components, see your FTAM and Virtual Terminal documentation.

5.10.1 Interpreting Trace Information

The readable file that the `ositrace` utility creates contains the following information about the protocol data units (PDUs) for each traced layer (see the example in this section and in Appendix B):

1. A timestamp (day, date, and time) precedes the formatted textual output of the file that the trace utility generates. The timestamp indicates when the trace started. Another timestamp that indicates when the trace ended appears at the end of the file.
2. The time (hh:mm:ss) that the outbound or inbound PDUs were sent or received.
3. The direction of the PDUs: a left arrow (< -) indicates inbound PDUs and a right arrow (- >) indicates outbound PDUs.
4. The layer for which the PDUs are being traced: FTAM, Virtual Terminal (VT), ACSE, Presentation, or Session.
5. The hexadecimal dump of the PDUs formatted from left to right into eight columns of eight-character (1 octet) sequences.
6. The textual translation of PCI data in ASN.1 notation (columns 1-72), followed by the first three hexadecimal bytes of the hexadecimal sequence being described (columns 73-80).

Trace Example

```

1 10:11:57.08      OSI trace started Wed Jan 30 10:11:57 1992
2 10:11:58.20 3 --> 4 Session
5      0dff0148 05061301 00160102 14020002 33028080 34020103 c1ff0130 3180a080
      80010100 00a28081 02808082 020103a4 80308002 01010605 28c27b02 01308006
      02510100 00000030 80020103 060528c2 7b020230 80060251 01000000 00308002
      01050605 28c27b02 03308006 02510100 00000030 80020107 060528c2 7b020430
      80060251 01000000 00308002 01090606 2bce0f01 02023080 06025101 00000000
      30800201 0b060452 01000130 80060251 01000000 00000088 02060089 03054000
      61803080 02010ba0 7b6080a1 80060528 c27b0101 0000a280 06052bce 0f070100
      00a38002 01010000 be802880 020101a0 4da08082 01008302 03408403 05070085
      02058086 0100a780 4e0528c2 7b05014e 0528c27b 05024e05 28c27b05 034e062b
      ce0f0105 09000056 0776696e 63656e74 710a1908 6e69636b 73746572 00000000
      00000000 00000000 00000000
6      connect-spdu                                     0d ff 01
          connect/accept-item                           05 06
              protocol-options = NULL                   13 01
              version-number = 2                         16 01 02
          session-user-requirements = '0000000000000010'B 14 02 00
          ( duplex functional unit )
          calling-ssap-identifier =
          called-ssap-identifier =
          user-data                                       33 02 80
                                                         34 02 01
                                                         c1 ff 01

```

Solving DECnet-Plus Application Problems

5.11 Correcting FTAM Application Problems

5.11 Correcting FTAM Application Problems

Do the following if you isolate the problem as an FTAM application problem:

Step	Action
1	<p>Check that the initiator ID (user name) is a valid identifier on the responder's system.</p> <p>For the FTAM responder, the initiator ID must be a valid user name for that system. If the user name requires a password, it must be supplied as well.</p>
2	<p>Check that the filestore password is a valid account password for the user name. For a Digital FTAM responder, the filestore password must be the same as the login password.</p> <p>Not all FTAM vendors map the filestore password to the login password. If using FTAM products other than Digital's, check the appropriate documentation for further information.</p>
3	<p>If an account field is being sent to the FTAM responder on an OpenVMS system, check that the field is valid (0 to 8 characters).</p>
4	<p>On OpenVMS, check that the remote account specified by the initiator has read and execute access to the responder account's login command file.</p> <p>On OpenVMS systems, if there is no login command file, check that the symbol LGICMD points at NL: (the null device).</p>
5	<p>On OpenVMS, check that the remote account specified by the initiator has read and execute access to the responder command file (i.e., osif\$responder.com).</p>
6	<p>Check that the protection on input directories and files allows remote reading.</p>
7	<p>Check that the protection on output directories allows remote writing.</p>
8	<p>Check the following in the local database file:</p> <ul style="list-style-type: none">• For outbound connections, check that an alias is defined in the alias database.• Remember that aliases and their definitions are assumed to be all uppercase on OpenVMS, because OpenVMS is not case-sensitive. Because Digital UNIX is case-sensitive, interoperability problems between Digital UNIX and OpenVMS may occur if you do not use mixed-case address definitions carefully. Therefore, Digital recommends that you use only uppercase address definitions for PSEL, SSEL, and TSEL when trying to communicate between case-sensitive and case-insensitive operating systems such as Digital UNIX and OpenVMS.• Make sure the local database entry specifies a correct AE-qualifier, AP-title, PSEL, SSEL, TSEL, and NSAP. If the PSEL, SSEL, TSEL entries are represented as ASCII characters, be sure the case is correct.• Make sure that the NSAP, provider name, and template name are consistent and valid. For example, be careful not to mix RFC 1006 specifications with OSI specifications.

5.12 Correcting FTAM File-Handling Problems

This section contains suggestions for dealing with possible file-handling problems.

5.12.1 Checking Foreign Filename Formats

On OpenVMS systems, when specifying a foreign file name, you must enclose the name in double quotation marks (" "), so RMS does not parse the name. Enclose the file name in double quotation marks to preserve the case of the file name. It is best to ensure that all file names are in uppercase.

On UNIX systems, when specifying foreign file names, you must enclose the name in single quotation marks (' ').

Be aware that case sensitivity may be an issue when transferring files between OpenVMS and UNIX systems.

5.12.2 Correcting File Problems

If copied files appear to have extra characters, the remote FTAM implementation may be having problems handling the ISO 8859 character set. You can identify this problem if you display a file and see repeated escape sequences in the data. These escape sequences are the ISO 8859 character set identifiers. The remote FTAM implementation should have handled these. Refer to the supplier of that implementation for further information.

Other file problems may be related to the way the file was transferred. Problems can occur if the requested format is unsupported. The FTAM implementation must convert the file to a supported format before it can transfer it properly (see your FTAM management documentation). If an FTAM file on an OpenVMS system file does not look correct, the software probably transferred it as an FTAM-3 file, which is the default format.

Do the following to check FTAM file formats:

On OpenVMS Systems:	On Digital UNIX Systems:
Enter this command: <code>\$ dir/application_protocol=ftam/full filename</code>	Enter this command: <code>% ols -A application-name::file</code>

The displayed record tells you the format of the file, which can be:

- Stream – FTAM-1
- Variable Length – FTAM-2
- Undefined – FTAM-3

Solving DECnet-Plus Application Problems

5.13 Correcting General FTAM Connection Problems

5.13 Correcting General FTAM Connection Problems

If your system environment is set up correctly and a connection attempt fails, do the following:

Step	Action
1	<p>Check that the <code>osak\$server_v3.exe</code> process (OpenVMS systems only) or the <code>ftam_listener</code> process (Digital UNIX systems only) is running. Do the following:</p> <ul style="list-style-type: none">• On OpenVMS systems, do one of the following:<ul style="list-style-type: none">– Enter the OpenVMS command <code>show system</code> and look for the processes: <code>OSAK\$SERVER_V3</code> <code>OSAK\$NETMAN</code>– Enter the following DCL command: <code>\$ show process osak\$server_v3.exe</code> If <code>osak\$server_v3.exe</code> is running, a summary of the process appears.• On Digital UNIX systems, enter the following command: <code>% ps axuw grep ftam_listener</code>
2	<p>If necessary, start the <code>osak\$server_v3.exe</code> process (OpenVMS only) or the <code>ftam_listener</code> process (Digital UNIX only) by doing one of the following:</p> <ul style="list-style-type: none">• On OpenVMS systems, start the <code>osak\$server_v3.exe</code> process from a process with <code>SYS\$PRV</code> privileges by entering the following DCL commands: <code>\$ @sys\$startup:osak\$start.com</code> <code>\$ @sys\$startup:osif\$startup.com</code>• On Digital UNIX systems, run the file <code>/etc/osi_applstartup</code> as root.
3	<p>Invoke NCL and use the command <code>show node</code> to see if the OSI transport software is running. For example:</p> <pre>ncl> show node 0 osi transport state</pre> <p>If OSI transport is running, NCL displays a message stating that the status state equals <code>on</code>. For example:</p> <pre>Show Node 0 OSI Transport at 199201-10-15::53.63400 + 00:00 I 00.00000 Status State = On</pre> <p>If OSI transport is not running, NCL displays a message stating that the status state equals <code>off</code>. For example:</p> <pre>Show Node 0 OSI Transport at 1992-01-10-15:41:53.63400 + 00:00 I 00.00000 Status State = Off</pre>

Solving DECnet-Plus Application Problems

5.13 Correcting General FTAM Connection Problems

Step	Action
4	If OSI transport is not running, do one of the following: <ul style="list-style-type: none">• On an OpenVMS system, exit NCL and execute the OSI transport startup command file <code>sys\$startup:osit\$startup.com</code> from an account with SYSPRV. After restarting OSI transport, restart the <code>OSAK\$SERVER_V3.EXE</code>.• On a Digital UNIX system, exit NCL and execute the file <code>/etc/start_osi_transport.ncl</code> as root.
5	Check that the underlying DECnet software is running. From a privileged account, type the following at the NCL prompt: <pre>ncl> show session control state</pre> The state should be On.
6	If you want to make a connection over an X.25 or Internet network from an OpenVMS system, you must have the X.25 software installed and running.

5.14 Correcting FTAM and Virtual Terminal Connection Problems (Digital UNIX Only)

If no error messages appear when you try to establish a connection but the connection attempt fails, create an initiator trace for the command that failed, as described in Section 5.8.

Use the procedures in the following sections if errors appear.

5.14.1 Address in Use

If the message is Address in Use, do the following:

Step	Action
1	Examine <code>/etc/isoapplications</code> for incorrect entries. Check that all entries contain the appropriate components and delimiters. If you find errors, correct them and retry the operation. If the file is correct, go to step 2.
2	Check that another process is not listening on the same transport address. Do the following: <ol style="list-style-type: none">Use either the <code>ps axuw grep ftam</code> or <code>ps axuw grep vt</code> command to see if another process is running.If no process is running, use the following NCL command to look for descriptions of local transport selectors in use: <pre>show osi transport * all</pre> If any transport service access points (TSAPs) match the one that the <code>ftam_listener</code> or <code>vt_listener</code> is trying to use, then the <code>ftam_listener</code> or <code>vt_listener</code> must use a different one.

Solving DECnet-Plus Application Problems

5.14 Correcting FTAM and Virtual Terminal Connection Problems (Digital UNIX Only)

5.14.2 Network Is Unreachable

If the message is `Network is unreachable`, check that a listener/responder process is running on the remote node that can accept your connection request. There may be no way to reach the remote node.

Also, verify that the transport provider specified by the initiating entry is available on the responding entity.

5.14.3 Connection Refused

If the message is `Connection refused`, the Transport layer received a disconnect from the remote system. Retry the operation or specify a different remote node. You can also check a trace, if it exists, for a diagnostic message that indicates why the remote system refused the connection.

5.14.4 Connection Timed Out

If the message is `Connection timed out`, the remote node did not respond to your connection request. There may be no way to reach the remote node or no responder listening on the specified address.

5.15 Correcting FTAM and Virtual Terminal Responder Problems (OpenVMS Only)

Use the procedures in this section if an FTAM or VT responder on an OpenVMS system either terminates unexpectedly or will not start.

5.15.1 Correcting Unexpected Termination Problems

Try the following if an FTAM or Virtual Terminal responder on OpenVMS systems terminates unexpectedly:

Step	Action
1	Examine the operator log for events prior to the failure. If indicated, change system parameters.
2	If no error exists in the operator log, or if changing system parameters does not correct the problem, perform a trace of the operation.
3	Check that there are no problems with the OSI transport provider (see Chapter 7).

5.15.2 Correcting Responder Starting Problems

Try the following if an FTAM or Virtual Terminal responder on OpenVMS systems will not start:

Step	Action
1	Use the DCL command <code>show system</code> to check that a responder is not already running on the same node. The application startup file usually prevents this from happening; check the startup file to see if it was incorrectly modified.
2	Check the alias database to see if another application is using the same TSAP.
3	Check that there are no problems with the OSI transport provider (see Chapter 7).

5.16 Correcting FTAM and Virtual Terminal Responder Problems (Digital UNIX Only)

5.16 Correcting FTAM and Virtual Terminal Responder Problems (Digital UNIX Only)

Try the following if you have FTAM or Virtual Terminal responder problems on Digital UNIX systems:

Step	Action
1	If the responder does not start, check the <code>/usr/adm/syslog.dated/*/daemon.log</code> file for errors that the <code>ftam_listener</code> or <code>vt_listener</code> generated. If no errors exist, go to step 2.
2	Start the responder (using <code>ftamd</code> or <code>ologind</code>) at the terminal and use the tracing option to generate a trace file.
3	Correct errors indicated by the trace file.
4	Make sure the addresses and transport options specified in the <code>/etc/isoapplications</code> file are correct.

5.17 Correcting FTAM Environment Problems (OpenVMS Only)

FTAM connections to remote systems can fail if the OpenVMS environment is not set up correctly. If any connections fail, first check that the size of the `sysgen` parameter, `maxbuf`, is at least 2048.

If inbound connections fail, check the following items in your OpenVMS environment:

Solving DECnet-Plus Application Problems

5.17 Correcting FTAM Environment Problems (OpenVMS Only)

Step	Action
1	Check the address database: <ul style="list-style-type: none">• Make sure a valid user name and password are specified for the local application address.• Make sure the AP-title, AE-qualifier, PSAP, SSAP, TSAP, and NSAP on both the initiating and responding systems are correct and match.
2	Make sure the responder's default directory has write access and sufficient space for writing log files.
3	Check the local account where the responder runs to see that: <ul style="list-style-type: none">• BYTLM is set to at least 20,000 bytes.• The account allows network operation (NETMBX and TMPMBX privileges).• NETWORK is enabled for the account in AUTHORIZE.• If a restricted account is used, an accessible login.com file exists, or the symbol LGICMD points to NL: (the null device).
4	Check to see if maximum activity levels are being exceeded for networking processes, transport connections, X.25 connections, and other processes.
5	Check the disk to make sure it: <ul style="list-style-type: none">• Has sufficient space to receive an inbound data transfer. Use the FTAM command <code>directory/app=ftam/size=all</code> to determine the blocks used and blocks allocated for a file on any FTAM system on your open-systems network.• Is not write-locked.

5.18 Correcting Target SAP Connection Problems

Connections can fail if a problem with a specific service access point exists. The following procedures describe how to correct problems in the OSI layers.

5.18.1 Correcting FTAM Physical and Data Link Problems

Do the following to verify that the network topology can reach the remote system:

Step	Action
1	On OpenVMS systems only, look at the DECnet OPCOM messages to check that the remote system is available. On Digital UNIX systems only, check the <code>/usr/adm/syslog.dated/*/daemon.log</code> file.
2	Check that the physical network wires are connected.

5.18.2 Correcting Network Connection Problems

Use NCL commands to do the following:

Solving DECnet-Plus Application Problems

5.18 Correcting Target SAP Connection Problems

For Direct X.25 Access:

Step	Action
1	<p>Check that the X.25 address in use is correct:</p> <ul style="list-style-type: none">• For inbound connection attempts, ensure that the source system uses your DTE address and the appropriate subaddress or call value (if used). Source systems would use the transport subaddress of your X.25 transport template. If Call User Data is used in place of a subaddress, ensure that the value of the Call User Data is correct. Some systems do not send out Call User Data by default.• For outbound connection attempts, ask the target system manager to verify the DTE address and transport subaddress that form the X.25 address in your OSI transport address. Some systems require that Call User Data (03010100) be present to select the ISO transport application at the target system. Ensure that the value of the Call User Data (if used) is correct.
2	Check that both systems are using the agreed-upon call value for the network.
3	Check local DNIC usage to determine if it needs a leading zero (0) or one (1).
4	Check to see if international DNIC usage is always required.
5	See the X.25 problem-solving documentation for further assistance.

For Direct IEEE 802 Access:

Step	Action
1	<p>Check that the physical address in use is correct. Do the following:</p> <ul style="list-style-type: none">• For inbound connection attempts, ensure that the remote system uses the physical address for the Ethernet device that connects your system to the IEEE 802 subnetwork shared by your systems.• For outbound connection attempts, ask the target system manager to verify the physical address that you are using in your OSI transport address.

For Internet Access:

Step	Action
1	<p>Check that the NSAP addressing information is correct:</p> <ul style="list-style-type: none">• Check that the specified transport provider is rfc1006.• Check that the specified NSAP is a 4-byte Internet address.• For inbound connection attempts, ensure that the remote system manager is using a valid network service access point (NSAP) address in the isoapplications database.• For outbound connection attempts, ask the system manager of the target system to verify that the NSAP address specified in your OSI transport address identifies the NSAP of the target system.
2	Check that the adjacency addressing is defined and is correct:

Solving DECnet-Plus Application Problems

5.18 Correcting Target SAP Connection Problems

Step	Action
	<p>For X.25 subnetwork access:</p> <ul style="list-style-type: none">• For inbound connection attempts, ensure that the adjacent system uses your DTE address and the appropriate subaddress (if used). Adjacent systems would use the transport subaddress of your X.25.• For outbound connection attempts, ask the adjacent system manager to verify the DTE address and Internet subaddress that form the X.25 address in your adjacency address.• Check that both systems are using the agreed-upon call value for the subnetwork. <p>For IEEE 802 subnetwork access:</p> <ul style="list-style-type: none">• For inbound connection attempts, ensure that the adjacent system uses the physical address for the Ethernet device that connects your system to the IEEE 802 subnetwork shared by your systems.• For outbound connection attempts, ask the adjacent system manager to verify the physical address that you are using in your adjacency address.• Check that the routing database is correct for the current configuration. Use NCL to confirm that the target system is assigned the correct adjacency address. Also, if other types of routing information are required (as indicated in your OSI transport management documentation), ensure those values are correct. <p>Run an OSI transport trace to learn whether the Internet packets are getting through. See your OSI transport documentation for further information.</p>

Solving DECnet-Plus Application Problems

5.18 Correcting Target SAP Connection Problems

5.18.3 Correcting FTAM and VT Transport Problems

Do the following to correct transport problems:

Step	Action
1	<p>Check that the transport selectors for the initiator and responder match. The transport selector is the right-hand selector in an upper-layer address. On OpenVMS systems, display any upper-layer address defined for a responder or initiator. For example:</p> <ul style="list-style-type: none">• For inbound connections, use the NCL command <code>show osak application * address</code>.• For outbound connections, check the file <code>sys\$system:isoapplications.dat</code>. <p>On Digital UNIX systems, check the <code>/etc/isoapplications</code> file.</p>
2	<p>Check the format of the TSAP value to see if it is hexadecimal or ASCII.</p>
3	<p>Make sure that timers are not causing a disconnect too quickly; for example, the keepalive timer of the network service should be used.</p>
4	<p>Check that the correct transport template name is in use.</p>
5	<p>If you use Internet, check the addresses used and routing table entry.</p>
6	<p>If you use null Internet, check the OSI transport template to see if the inactive area address supplied matches the routing circuit.</p>
7	<p>Look at the transport counters to see if the transport software is working. See your DECnet-Plus management documentation for further information.</p>

5.18.4 Correcting FTAM and VT Session Problems (OpenVMS Only)

Do the following to correct FTAM and VT problems at the Session layer on OpenVMS systems:

Step	Action
1	<p>Check that the session selectors for inbound and outbound connections match. The session selector is the middle selector in an upper-layer address.</p> <p>For inbound connections, if you need addressing information for the FTAM responder, use the NCL command <code>show osak application</code>.</p> <p>For outbound connections, check the file <code>sys\$system:isoapplications.dat</code>.</p>
2	<p>Check that the session versions of the two systems are compatible.</p> <p>An FTAM responder can accept either version 1 or 2. If both versions are proposed on an F-INITIALIZE indication, the responder chooses version 2. By default, an FTAM initiator proposes version 2. However, you can override the default by entering version 1 or versions 1 and 2 into the alias entry for a given remote application.</p> <p>To define the session version for an alias, edit the alias entry in <code>sys\$system:isoapplications.dat</code>.</p>
3	<p>Check whether the values used are hexadecimal or ASCII, and whether the values are correct.</p>

Solving DECnet-Plus Application Problems

5.18 Correcting Target SAP Connection Problems

5.18.5 Correcting FTAM and VT Presentation Problems (OpenVMS Only)

Do the following to correct connection problems at the Presentation layer:

Step	Action
1	<p>Check that the presentation selectors on the initiator and responder systems match.</p> <p>The presentation selector is the left-hand selector in an upper-layer address.</p> <p>For inbound connections, if you need addressing information for the FTAM responder, use the NCL command <code>show osak application</code>.</p> <p>For outbound connections, check the file <code>sys\$system:isoapplications.dat</code>.</p>
2	<p>Check if there are common syntaxes for ACSE-PCI, FTAM-PCI, FTAM-FADU, unstructured binary, and unstructured text. FTAM uses the basic encoding rules of a single ASN.1 type as its transfer syntax.</p>
3	<p>Check whether the values used are hexadecimal or ASCII, and whether the values are correct.</p>

5.19 Correcting Problems with Applications Using OSAK

OSI application failures can indicate that a problem exists with their use of the OSI Applications Kernel (OSAK) software. Check the application's documentation to determine if the application has any dependencies on the OSAK software or uses the OSAK application programming interface.

Refer to the following documentation for more information about OSAK software and the OSAK application programming interface:

- DECnet-Plus network management documentation
- OSAK Programming and Programming Reference documentation
- Documentation for any applications that use the OSAK software

5.19.1 Correcting Connection Problems

Do the following if an application that uses OSAK software has connection problems:

Step	Action
1	<p>Use the Common Trace Facility or the OSAK trace utility to get a transport trace and examine the output for the following:</p> <ol style="list-style-type: none">Check that a transport connection was established. There should be a Connect Confirm (CC) transport protocol data unit (TPDU) in the trace.If no CC TPDU exists, and the application uses the OSAK programming interface, check that the <i>called_aei</i> parameter that the initiator supplies matches the local address of the responder.Check that the Data Transfer (DT) protocol data unit (PDU) containing the upper-layer connect was received.
2	<p>If possible, examine the application's log file to check that the local application received the upper-layer connect.</p>
3	<p>Check that quotas were not exceeded.</p>

Solving DECnet-Plus Application Problems

5.19 Correcting Problems with Applications Using OSAK

5.19.2 Correcting Unexpected Termination Problems

Do the following if the application terminates unexpectedly:

Step	Action
1	Check the OSAK event sink (OpenVMS only) or the NCL event sink (Digital UNIX only) for evidence of protocol errors.
2	Create a transport trace using the OSAK trace utility, with the Errors option enabled. If errors exist, report them to the originator of the PDU; this is the local system for outbound messages and the remote system for inbound messages. There can be errors in the PDU that tracing cannot detect, so you cannot assume that the PDU is correct even if no errors are reported. If no errors exist, check the lower layers of your network.

5.19.3 Correcting Programming Problems

Do the following for programming problems:

Step	Action
1	Check that optional parameters are set to null.
2	Make sure you have sufficient workspace.
3	Check that you have allocated enough buffers.
4	Make sure that the application checks returned status information.

Solving Session Control Problems

This chapter describes how to isolate and correct Digital Network Architecture (DNA) application faults that can be a result of a Session Control problem. DNA application failures can also be a result of:

- Application-specific problems (refer to the application's documentation)
- Name service problems (see Section 6.10)

Topics In This Chapter

The topics in this chapter are:

- Underlying Components for Session Control (OpenVMS Only) (Section 6.1)
- Underlying Components for Session Control (Digital UNIX Only) (Section 6.2)
- Symptoms of Session Control Problems (Section 6.3)
- Isolating Session Control Faults (Section 6.4)
- Correcting Unknown Application Problems (Section 6.5)
- Correcting Application Too Busy Problems (Section 6.6)
- Correcting Access Control Problems (Section 6.7)
- Correcting Insufficient Resource Problems (Section 6.8)
- Correcting Timed Out Problems (Section 6.9)
- Correcting Node Name Resolution Problems (Section 6.10)
- Examining the DECnet-Plus Naming Cache (OpenVMS Only) (Section 6.11)

Solving Session Control Problems

6.1 Underlying Components for Session Control (OpenVMS Only)

6.1 Underlying Components for Session Control (OpenVMS Only)

Figure 6–1 shows the direct underlying components that the Session Control software on OpenVMS systems use. Use this information as a guide during fault isolation.

Solving Session Control Problems

6.1 Underlying Components for Session Control (OpenVMS Only)

Figure 6-1 Underlying Components for Session Control (OpenVMS)

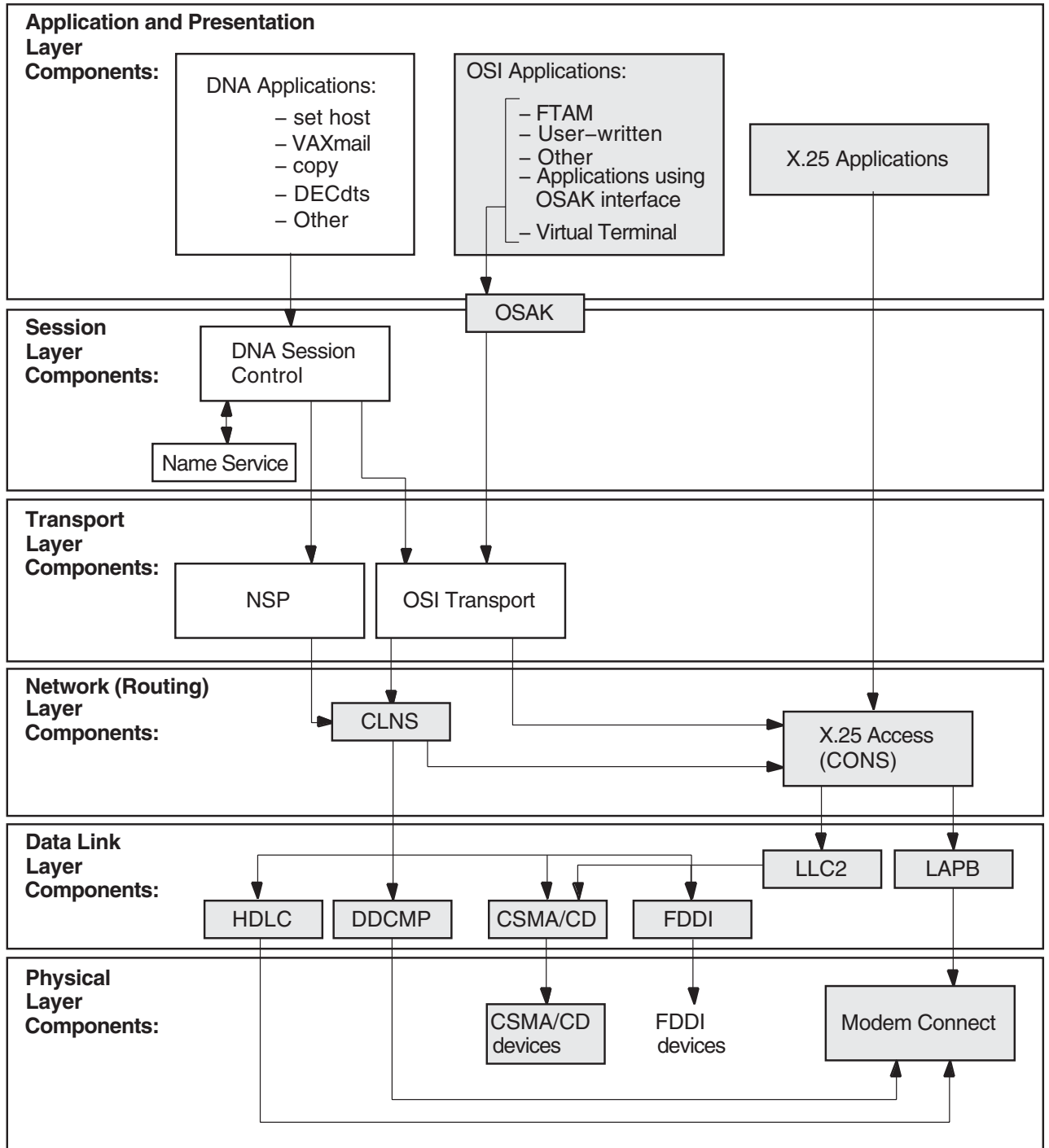

LKG-09725-96R

Solving Session Control Problems

6.2 Underlying Components for Session Control (Digital UNIX Only)

6.2 Underlying Components for Session Control (Digital UNIX Only)

Figure 6-2 shows the direct underlying components that the Session Control software on Digital UNIX systems use. Use this information as a guide during fault isolation.

Solving Session Control Problems

6.2 Underlying Components for Session Control (Digital UNIX Only)

Figure 6-2 Underlying Components for Session Control (Digital UNIX)

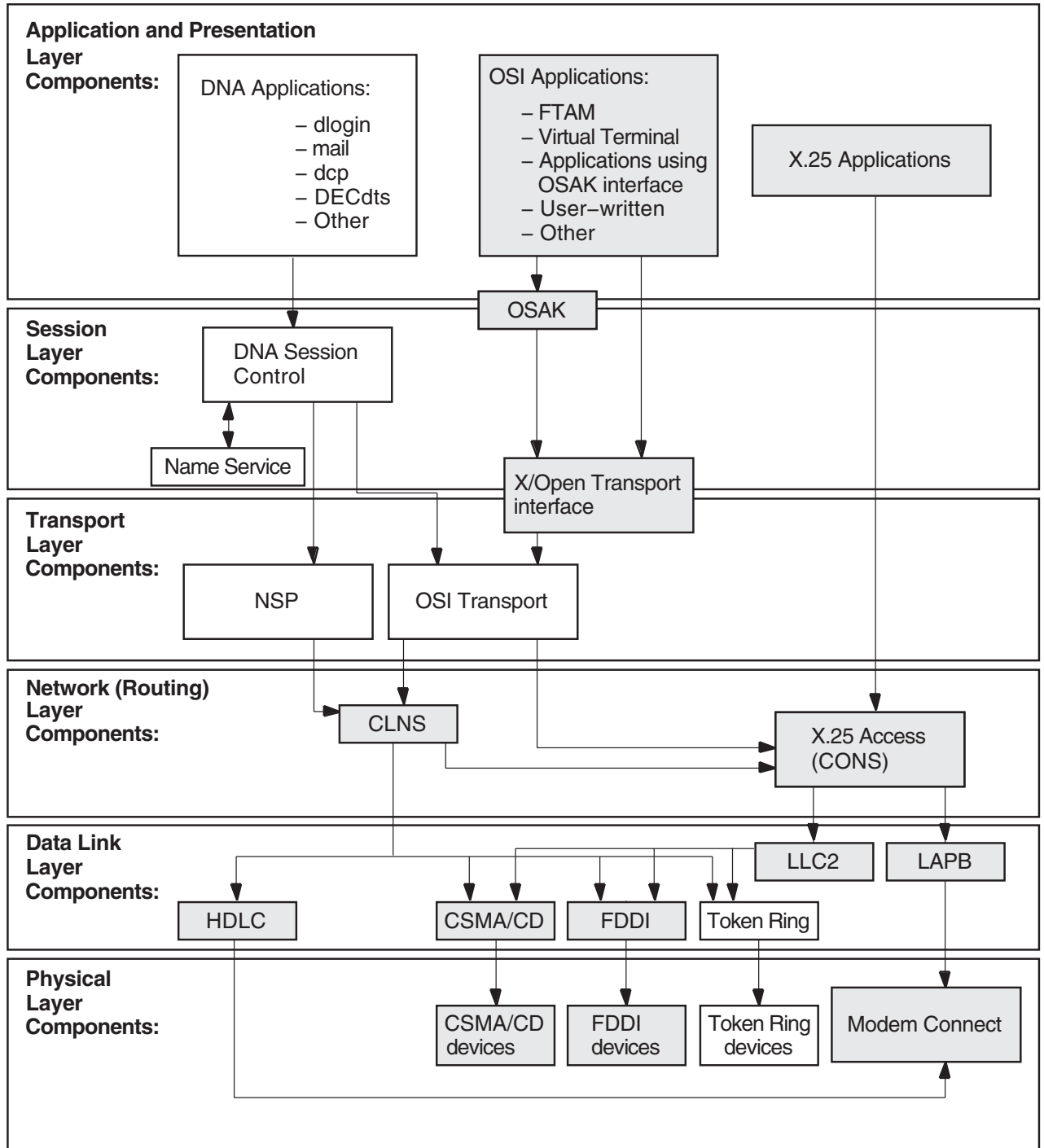

LKG-09726-96R

6.2.1 References

Refer to your application's documentation if you determine that an application-specific problem caused a failure. Refer to Section 6.10 if you determine that a name service problem caused a failure.

Solving Session Control Problems

6.3 Symptoms of Session Control Problems

6.3 Symptoms of Session Control Problems

The symptoms in Table 6–1 indicate that the local system attempted to establish a connection to the remote system, but a problem with the Session Control software, or with the naming information that Session Control uses, prevented the requested operation from completing.

Table 6–1 Symptoms of Session Control Problems

Symptom	Possible Problem	See:
Unknown application at remote node or object is unknown at remote node	The address that the application used does not match the data in the Session Control application database on the remote node. You attempted to connect to the wrong node.	Section 6.5
Access control rejected	Proxy access is not defined correctly. Node name validation on source node failed or an invalid user name or password was used.	Section 6.7 Section 6.7.3
Application too busy	The remote node is receiving too many connection requests before the application or the Session Control software can process them.	Section 6.6
Remote node is unreachable	Incompatible tower information exists for the source and destination node.	Section 6.10
Session Control has insufficient resources	Maximum number of available ports are all in use.	Section 6.8
Timed out	Local cache did not contain the correct information and Session Control took too long to retrieve naming information from a remote server. Outgoing or incoming request timer is set too low. Server application does not declare itself (for example, on an OpenVMS system, when the application used IO\$ACPCONTROL, GET_CONNECTION or during process creation).	Section 6.9 or Section 6.10
Wrong information displayed or wrong account accessed	Proxy entries on local node do not match those on the remote node and the system logs you in to a default user account.	Section 6.7.2 or 6.7.1

(continued on next page)

Solving Session Control Problems

6.3 Symptoms of Session Control Problems

Table 6–1 (Cont.) Symptoms of Session Control Problems

Symptom	Possible Problem	See:
Unable to obtain the address for a node	The name service is not available. The name service search path is not correctly set up.	Section 6.10

6.4 Isolating Session Control Faults

Session Control problems can be the cause of DNA application failures that are not application specific. Session Control problems can occur because of:

- Name service problems (see Section 6.10)
- Session Control entity problems
- Transport layer problems (see Chapter 7)
- Network layer problems (see Chapter 8)

Before trying any correction procedures, do the following to isolate the problem to the appropriate area:

Step	Action
1	<p>Try to establish a connection using a different application.</p> <p>If the connection succeeds, an application-specific problem exists. Refer to the documentation for the application that failed.</p> <p>If the connection attempt fails, Session Control cannot complete the connection request. Continue fault-isolation procedures to determine if the problem is caused by the namespace operation, Session Control entity problems, or a lower-layer problem.</p>
2	<p>Check whether the remote node is reachable. Use quick reachability or loopback tests or trace the network path between the nodes. Or, try using a different source node to connect to the remote node.</p> <p>If the source node cannot reach the remote node, check the nodes in the path to determine the problem.</p> <p>If the remote node is reachable, go to the next step.</p>
3	<p>Attempt to connect to the remote node using the remote node's address.</p> <p>If the connection succeeds, check the naming information that Session Control uses. See Section 6.10.</p> <p>If the connection fails, check the lower-layer operation on the local and remote node (see Chapters 7 and 8).</p>

6.4.1 Tools and Commands to Use

To:	Use This Tool or Command:
Quickly confirm that remote node is reachable.	set host or dlogin with node address. If test succeeds, examine your DECdns namespace or local database.
Confirm the remote node is reachable.	Loopback tests, see Section 3.1.1
Examine the Session Control component.	NCL Session Control commands

Solving Session Control Problems

6.4 Isolating Session Control Faults

To:	Use This Tool or Command:
Check naming information.	Trace facility, see Section 6.10

6.4.2 Fault-Isolation Methodology

Use Figure 6–3 as a guideline for isolating Session Control faults.

Solving Session Control Problems

6.4 Isolating Session Control Faults

Figure 6-3 Fault-Isolation Methodology (Session Control)

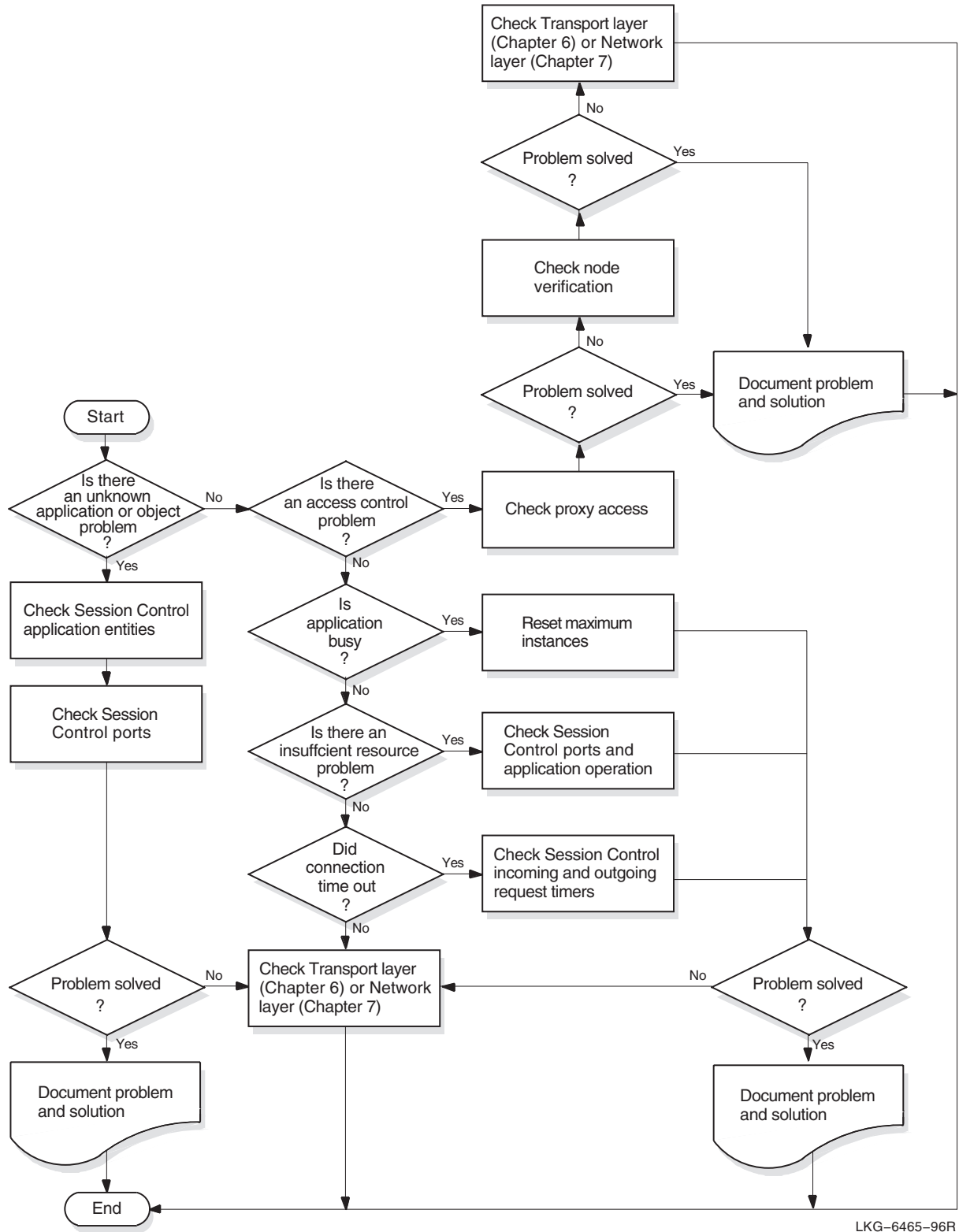

LKG-6465-96R

Solving Session Control Problems

6.5 Correcting Unknown Application Problems

6.5 Correcting Unknown Application Problems

This type of message can appear if:

- The end-user specifications on the target system do not match the end-user specifications that the application uses on the originating system.
- The file that an application invokes on an incoming request exists and the account using it cannot execute the file.

Check that you (or the application) used the correct node name. If the correct node name was used, do the following to fix this problem:

Step	Action
1	Use the following NCL command to get information about applications that activate an image file or command procedure when they receive incoming requests (referred to as initiator applications): <pre>ncl>show session control application * - _ncl>all characteristics</pre>
2	Examine the display for the following information: <ul style="list-style-type: none">• Address – This is the application's object names or numbers. <code>number=XX</code> indicates the object number; <code>name=xxx</code> indicates the object = 0, with the specified name.• User name – This is the account under which the application runs for default access.• Image name – This is the file that is the target for the connection.
3	Identify the applications that are daemons (referred to as declared responders). Use one of the following NCL commands: For OpenVMS systems: <ul style="list-style-type: none">• <pre>ncl> show session control port * all attributes, - _ncl> with creation time > <i>timestamp</i></pre>• <pre>ncl> show session control port * all attributes, - _ncl> with direction=incoming</pre> For Digital UNIX systems: <ul style="list-style-type: none">• <pre>ncl>show session control port * all attributes, - _ncl> with creation time > <i>timestamp</i></pre>• <pre>ncl>show session control port * all attributes, - _ncl> with direction=listening</pre>
4	Identify the local end user address. This address is the object name or number of the application. Use the following NCL command: <pre>ncl> show session control port * - _ncl>local end user address</pre>

Solving Session Control Problems

6.5 Correcting Unknown Application Problems

Step	Action
5	<p>Check the following:</p> <ul style="list-style-type: none">• The value of the Address attribute and the object name or number that the originator of the incoming request used match these values on the remote node.• The file indicated by the Image Name field:<ul style="list-style-type: none">– If the file does not exist, copy it from another location or reinstall the application.– If the account specified in the User Name field cannot access the file, change the file's access so the account can use it.• The value of the Local End User Address field and the object name or number that the originator of the incoming request used match these values on the remote node.

6.6 Correcting Application Too Busy Problems

If you occasionally receive an application too busy problem, retry the operation after a short wait. If you frequently receive this message, do the following:

Step	Action
1	Refer to the application's documentation to determine if the application is configured properly.
2	<p>On Digital UNIX systems: Check the maximum instance characteristic for the application. Use the following NCL command:</p> <pre>ncl>show session control application - _ncl>application-id all.</pre> <p>If the maximum instances characteristic is equal to any value other than 0, it may be set too low. Use the following NCL command to reset this characteristic:</p> <pre>ncl> set session control application - _ncl>application-id maximum instance value</pre>

Solving Session Control Problems

6.7 Correcting Access Control Problems

6.7 Correcting Access Control Problems

Access control problems can occur if proxy access is not enabled correctly or if the software cannot find or validate specified node names. Do the following to determine what type of access control problem you have:

Step	Action
1	Make sure the user name that you or an application use is defined in the application or object database on the remote node.
2	Check to see if the failed application is checking for proxy access. For OpenVMS systems, see Section 6.7.1. For Digital UNIX systems, use an NCL command similar to one of the following to look at the session control ports in use: <pre>ncl>show session control port * proxy requested, - _ncl>with direction=listening</pre> If the proxy requested status is false, either the application did not request proxy access or outgoing proxy on the remote node is not enabled. Refer to the application's documentation or the following proxy access correction procedures.
3	Check the session control tower maintenance database to ensure the node is registered correctly. Use the following NCL command: <pre>ncl>show node <i>node-id</i> session control tower - _ncl> maintenance <i>name</i> all</pre> You can use an asterisk (*) instead of the <i>name</i> to display information for all nodes.

6.7.1 Correcting Proxy Access Problems (OpenVMS Only)

Do the following to check the proxy access:

Step	Action
1	Invoke the <code>authorize</code> utility and use the following command to check the proxy account: <pre>uaf>show/proxy *</pre>
2	If the proxy account is not set up correctly, use <code>authorize</code> commands to reset the proxy account values.
3	If you cannot access the proxy account, check to see if Session Control created an intrusion record for your client account on the target node. Issue the following DCL command: <pre>\$ show intrusion</pre>
4	If login attempts exceed the set acceptable number of times for the system, a break-in record will exist and the system may have disabled the account. Check the account using the <code>authorize</code> utility to see if the account was disabled.

Solving Session Control Problems

6.7 Correcting Access Control Problems

6.7.2 Correcting Proxy Access Problems (Digital UNIX Only)

Do the following to correct proxy access problems:

Step	Action
1	Look at the Outgoing Proxy characteristic on the originating node (client system). Use the following NCL command: <pre>ncl>show session control outgoing proxy</pre>
2	If the Outgoing Proxy characteristic on the originating node is FALSE , use the following NCL command to change it to TRUE : <pre>ncl>set session control outgoing proxy true</pre>
3	Look at the Incoming Proxy characteristic on the target node. Use the following NCL commands: <pre>ncl>show session control incoming proxy ncl>show session control application _ncl>application-id incoming proxy</pre>
4	If the Incoming Proxy characteristic on the target node is set to FALSE , use the following NCL commands to change it to TRUE : <pre>ncl>set session control incoming proxy true ncl>set session control application - _ncl>application-id incoming proxy true</pre>
5	Check that Session Control Proxy entities are defined correctly. Use the following NCL command: <pre>ncl> show session control proxy name - _ncl>all characteristics</pre> <p>Look at the following characteristics:</p> <ul style="list-style-type: none">• Target user – Should specify a valid account on the target system.• Applications – If empty, any application can use the proxy. If applications are listed, only those applications can use the proxy.• Type – If explicit, the originating system must specify a target user name that matches the target name of the proxy entry. If default, the originating system does not need to specify a target user name.• Source end users – Must specify the source node and user name that matches the source node and user name on the originating system.
6	If proxy entry on remote node is not defined correctly, modify existing proxy entry. Use NCL commands similar to the following: <pre>ncl>set session control proxy - _ncl>simple-name target user latin1-string, - _ncl>type default ncl> set session control proxy simple-name - _ncl>source end users - _ncl>{ [Node=node-id, End User=address] }</pre>
7	If you need to allow more than one end user to use the proxy entry, add additional source end-user information. Use the following NCL command: <pre>ncl>add session control proxy simple-name - _ncl>source end users - _ncl>{ [node =node-id, EndUser=id] }</pre>

Solving Session Control Problems

6.7 Correcting Access Control Problems

6.7.3 Correcting Node Name Validation Problems

A failure occurring when the remote system attempts to validate a node name can cause an access control problem. Do the following:

Step	Action
1	Check that the information in the namespace is correct (see your naming service documentation). Use the <code>cdi\$trace</code> program on the destination system to obtain additional information (see Section 6.10.1).
2	If a Phase IV system cannot connect to a DECnet-Plus system, and the DECnet-Plus system is using DECdns: <ol style="list-style-type: none">Use the <code>decnet_register</code> tool to check that the backtranslation soft links exist.Check that the tower maintenance update is succeeding. Use the following NCL command:<pre>ncl>show node <i>node-id</i> session control tower - _ncl>maintenance <i>fullname</i> all status</pre>If the last failure reason status attribute shows no error, check that the namespace is being updated correctly (refer to your DECdns documentation).
3	Make sure that the correct protocol towers information exists for the Node module on the local system.
4	Check that the node name in the synonym directory is correct.

6.8 Correcting Insufficient Resource Problems

Do the following if you have insufficient Session Control resource problems on a local or remote node:

Step	Action
1	Determine if the remote node is a Phase IV system or DECnet-Plus system.
2	If the problem occurs on a Phase IV system, use NCP to examine the maximum links (or maximum alias links). Use the following command: <pre>ncp> tell <i>node-id</i> show executor characteristics</pre> If the problem occurs on a DECnet-Plus system, use NCL to look at the Session Control ports. Use the following command: <pre>ncl> show session control port * all</pre>
3	Look at links or ports currently in use on the remote system. You can increase the links if necessary. Look at the link activity and the operation of the application to determine if you need more links or ports. Otherwise, examine the application operation to ensure it is configured properly.

6.9 Correcting Timed Out Problems

If you receive occasional timed-out errors, it is possible that Session Control had to take extra time to locate a specified node address. In this case, retry the failed operation. If you receive frequent timed-out errors, do the following:

Step	Action
1	If making a connection to an OpenVMS system, see if the complete <code>login.com</code> file is executed. If the remote system executes the complete <code>login.com</code> file when it receives a connect request, edit the file so only the necessary command lines execute. If the <code>login.com</code> file is not causing a problem, go to step 2.
2	Look at the incoming and outgoing request timer values. Use the following NCL command: <code>ncl>show session control all characteristics</code>
3	If the timer values seem too low, reset the values. Use NCL commands similar to the following: <code>ncl>set session control incoming timer seconds</code>

6.10 Correcting Node Name Resolution Problems

This section describes how to monitor DECnet-Plus node name and address resolution and search path processing.

During DECnet-Plus configuration, the system administrator sets up one or more name services on each node. This setup procedure includes generation of an NCL startup script that contains the name service search path information for the node.

The name service search path describes the following information:

- The order in which the name services are to be searched for node name and address information
- One or more *naming templates* for each name service to determine how DECnet-Plus should interpret abbreviated node names entered by users

For more information on name service configuration and search paths, refer to your DECnet-Plus installation and configuration guides.

For more information on DECdns, refer to *DECnet-Plus DECdns Management*.

6.10.1 Monitoring Search Path Processing (OpenVMS Only)

You can use either the Common Trace Facility or the `cdi$trace` program to obtain naming trace information.

Use the following command to invoke the Common Trace Facility:

```
$ Trace Start "SESSION CDI *"
```

Including the `CDI` parameter restricts trace facility output to node name and address resolution messages.

Use the following command to run `cdi$trace`, a program located in `SYS$SYSTEM`. For example:

```
$ run sys$system:cdi$trace
```

Solving Session Control Problems

6.10 Correcting Node Name Resolution Problems

You can use the following procedure to redirect `cdi$trace` output to a file:

1. Define a DCL foreign command symbol:

```
$ cdi$trace == "$cdi$trace"
```

2. Specify the name of the file to contain the `cdi$trace` output:

```
$ cdi$trace trace.log
```

The output file may occasionally be missing the last few records of the trace. This is a known problem.

Although `cdi$trace` has known problems when run during a LAT terminal session (on an LT device), a workaround is to issue the DCL `spawn` command first.

6.10.2 Tracing Node Name Resolution Problems (Digital UNIX Only)

You can trace DECnet-Plus node name and address resolution and search path processing on Digital UNIX systems by setting the environment variable `CDITRACE` to a non-zero number before using DECnet-Plus applications. For example,

```
> setenv CDITRACE 2
```

6.10.3 Displaying Search Path Information

Do the following to display the forward translation (node name to address) and backtranslation (address to node name) search paths for a system:

To:	Use This Tool or Command:
Display the forward translation search path.	<code>ncl> show session control naming - _ncl>search path</code>
Display the backtranslation search path.	<code>ncl> show session control backtranslation - _ncl>search path</code>

6.10.4 Identifying Namespace Consistency Problems

Using the `decnet_register` tool, you can verify that the reverse address mapping links and the synonym links for a node are set up properly in a name service.

The following `decnet_register` command reads the information for a node from a name service, checks the information for consistency, and prints messages describing any inconsistencies:

```
decnet_register>show node node-id full
```

6.11 Examining the DECnet-Plus Naming Cache (OpenVMS Only)

DECnet-Plus uses an in-memory naming cache to improve performance of name and address resolution for all supported name services. This naming cache supersedes the existing DECdns cache for storage of name and addressing information.

DECnet-Plus uses this naming cache rather than the DECdns cache, for name and address resolution requests for all three name services: DECdns, Local, and DNS/BIND.

The DECdns cache still exists and DECnet-Plus continues to use it to resolve the special namespace *nicknames:*, *local:*, and *domain:*. The prefixes *local:* and *domain:* on a node full name, indicate to DECnet-Plus the name service where the name and addressing information is stored.

Note that the DECdns cache continues to exist. Applications other than DECnet-Plus (for example, DFS) that use DECdns directly will continue to use the existing DECdns cache.

6.11.1 Managing the Naming Cache

Using NCL commands, you can manage two naming cache parameters, the checkpoint interval and the timeout period, and flush entries from the in-memory naming cache.

Refer to your network management guide for information on managing the in-memory naming cache.

6.11.2 Dumping the Naming Cache

Use the following procedure to dump the contents of the naming cache:

1. Checkpoint the cache to disk. One way to force a checkpoint is by setting the checkpoint interval. For example:

```
$ MCR NCL Set Session Control Naming Cache Checkpoint Interval 8:0:0
```

For improved performance, CDI checkpointing is deferred for up to 15 minutes after a checkpoint request. Wait to examine the file until the checkpoint actually occurs. If you monitor the CDI activity with `cdi$trace`, you will see the checkpoint occur.

2. Dump the on-disk checkpoint file by running `cdi_cache_dump`, a program located in `SYS$SYSTEM`.

For example:

```
$ run sys$system:cdi_cache_dump
```

Refer to your network management guide for information on managing the in-memory naming cache.

Solving Transport Problems

If you determine that an application failure is neither an application-specific, Session Control, or naming service problem, the next area to examine is the Transport layer. For the DECnet-Plus product, this means a problem could exist with either the OSI transport or Network Service Protocol (NSP) software.

Topics In This Chapter

The topics in this chapter are:

- Underlying Components (OpenVMS Only) (Section 7.1)
- Underlying Components (Digital UNIX Only) (Section 7.2)
- Symptoms of Transport Problems (Section 7.3)
- Isolating Transport Layer Problems (Section 7.4)
- Correcting Connection Problems (Section 7.5)
- Correcting OSI Transport Over CLNS Connection Problems (Section 7.6)
- Correcting OSI Transport Over CONS (X.25) Connection Problems (Section 7.7)
- Troubleshooting RFC 1006 (Section 7.8)

Solving Transport Problems

7.1 Underlying Components (OpenVMS Only)

7.1 Underlying Components (OpenVMS Only)

Figure 7–1 shows the direct underlying components that the NSP and OSI transport components use on OpenVMS systems. Use this information as a guide when isolating transport problems.

Solving Transport Problems

7.1 Underlying Components (OpenVMS Only)

Figure 7-1 Underlying Components (OpenVMS)

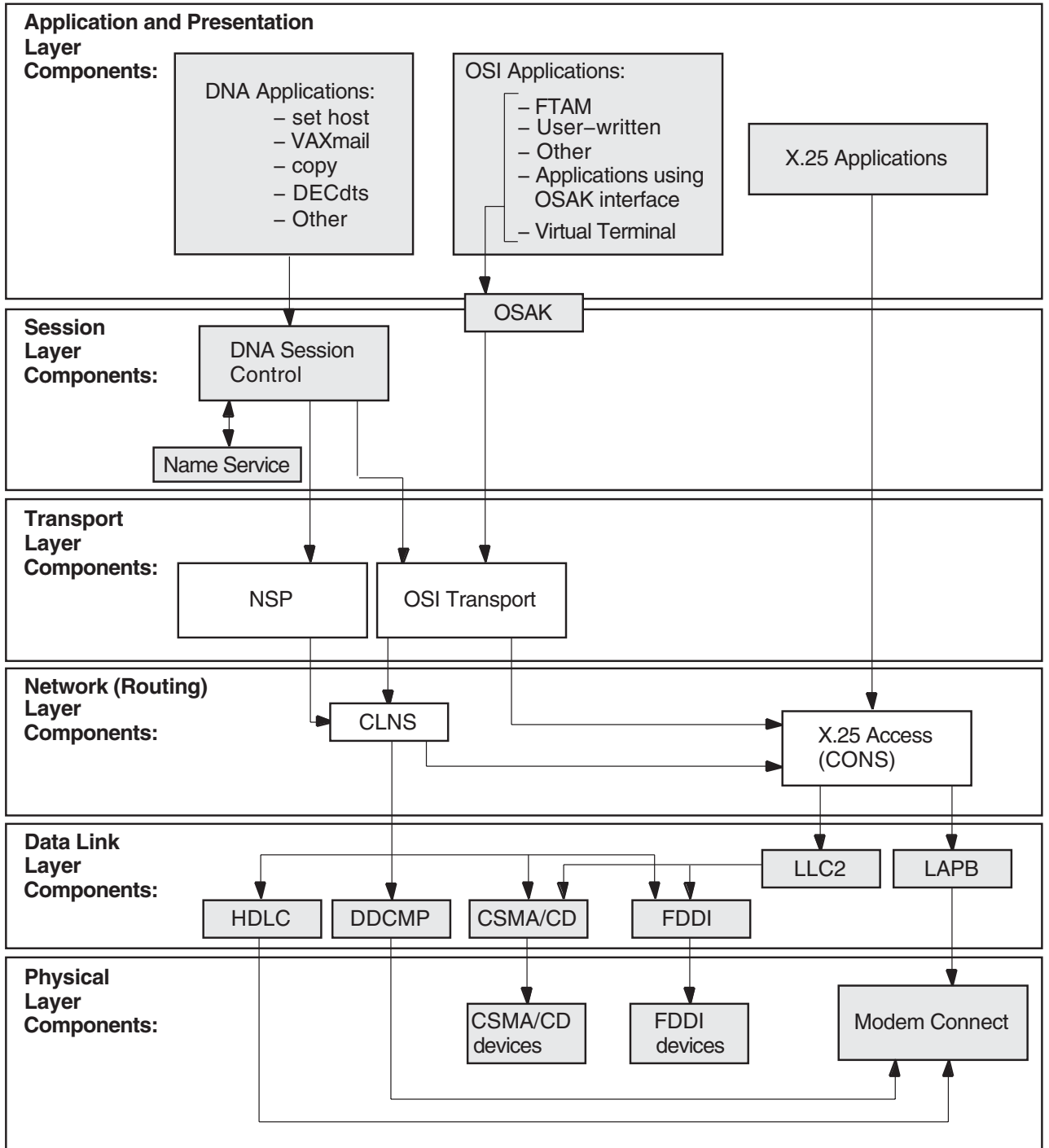

LKG-09683-96R

Solving Transport Problems

7.2 Underlying Components (Digital UNIX Only)

7.2 Underlying Components (Digital UNIX Only)

Figure 7–2 shows the direct underlying components that the NSP and OSI transport components use on DECnet-Plus systems. Use this information as a guide when isolating transport problems.

Solving Transport Problems 7.2 Underlying Components (Digital UNIX Only)

Figure 7-2 Underlying Components (Digital UNIX)

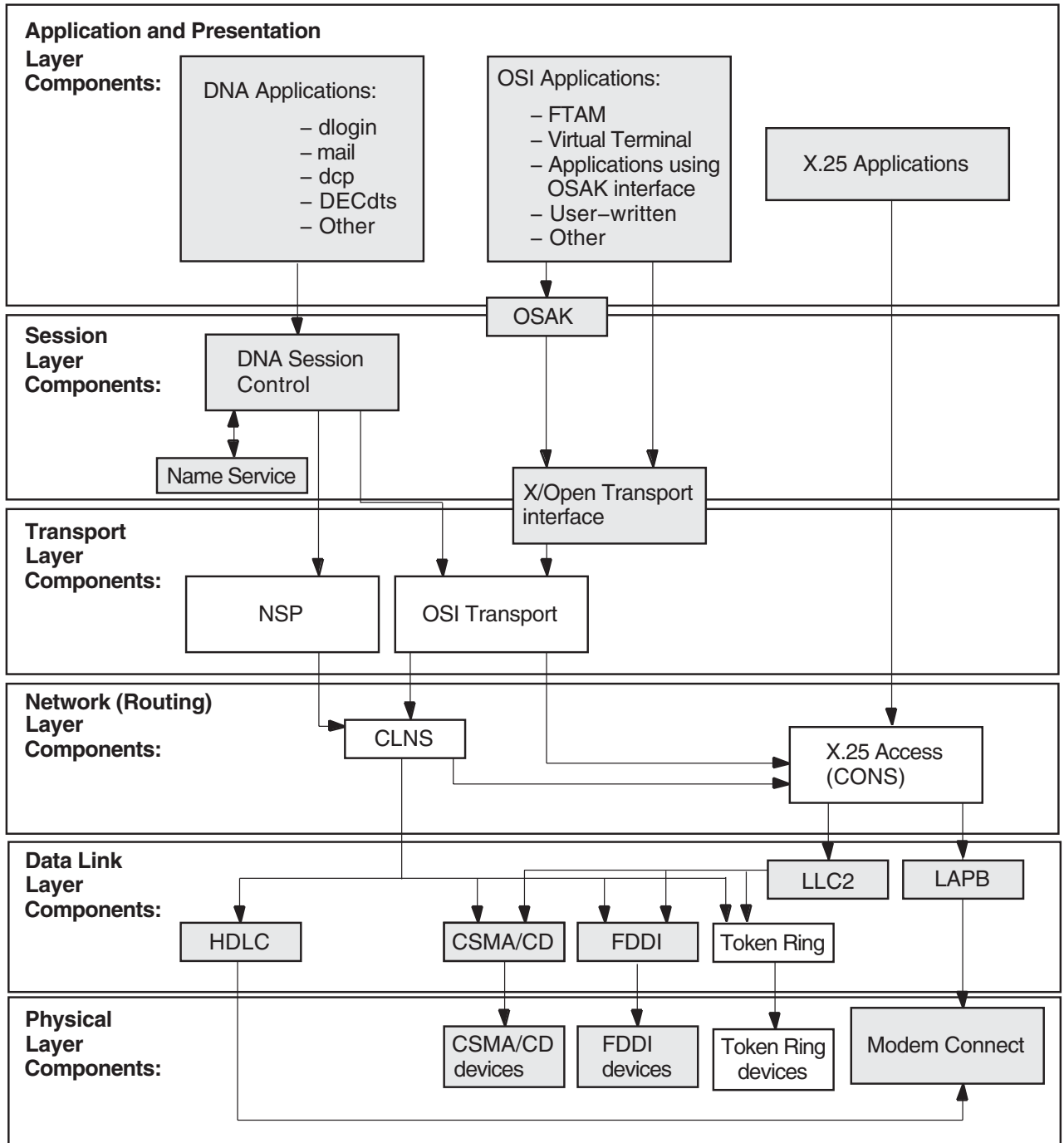

LKG-09684-96R

Solving Transport Problems

7.3 Symptoms of Transport Problems

7.3 Symptoms of Transport Problems

If attempts to connect to a remote node fail or time out and you cannot find any problems in the upper layers, it is possible that a Transport layer problem is the cause of the failure.

7.4 Isolating Transport Layer Problems

If you cannot isolate an application failure at the Session Control layer, the problem could be at the Transport layer. Or, the problem could exist at the Network layer, but examining the Transport layer provides you with information that will help you isolate the problem in the Network layer.

7.4.1 Tools to Use

Use the following tools to isolate Transport layer problems:

Tool	And Refer To:
NCL commands for the NSP and OSI transport modules	NCL reference documentation
dts/dtr tests, with /transport qualifier (DECnet-Plus)	Chapter 3
Common Trace Facility	<i>DECnet/OSI Common Trace Facility (CTF) Use</i>

7.4.2 Fault-Isolation Methodology

Use Figure 7-3 as a guideline for isolating Transport layer problems.

Figure 7-3 Fault-Isolation Methodology (Transport)

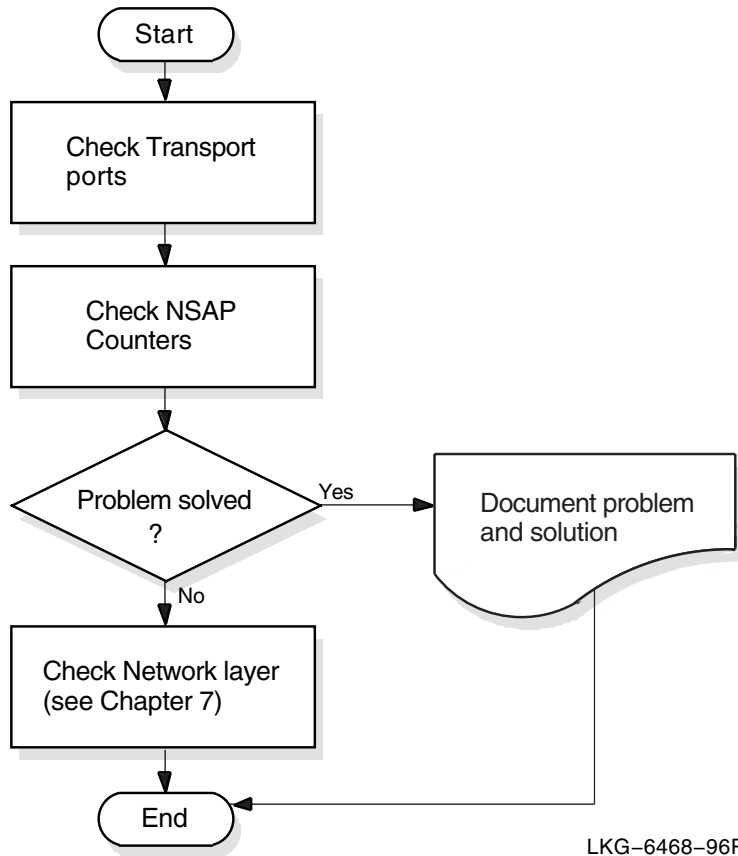

Solving Transport Problems

7.5 Correcting Connection Problems

7.5 Correcting Connection Problems

If it is unclear where transport connection problems are occurring, look at the related ports and NSAP counters. You can also use the Common Trace Facility.

7.5.1 Checking Ports

If you check OSI transport and NSP ports, you can see whether logical links between systems are being established. Do the following to check the ports:

Step	Action
1	<p>Disable the Transport layer software that you are not checking. Use one of the following NCL commands:</p> <pre>ncl>disable OSI transport ncl>disable NSP</pre> <p>If you disable either transport software, any connections that are currently using it are disconnected. The user can reconnect to the remote system (which then uses the other transport) if it supports the other transport and there are no other transport problems.</p>
2	<p>Initiate a connection to the target system.</p>
3	<p>Use the following NCL command to identify the transport port information for the Session Control ports in which you are interested (depending on which end of the connection you are checking, you specify direction as incoming or outgoing):</p> <pre>ncl> show session control port * all status, with - _ncl>direction=<i>value</i></pre>
4	<p>Display the information for the appropriate Transport layer port with one of the following NCL commands:</p> <pre>ncl>show NSP port <i>port-id</i> all attributes ncl>show OSI transport port <i>port-id</i> all attributes</pre>
5	<p>Check that the local NSAP and remote NSAP information used in the connection refers to the expected systems. Another cause of failure is incompatible NSAPs. A DECnet-Plus system needs a Phase-IV compatible address to allow communication between the DECnet-Plus system and a Phase IV system.</p>
6	<p>Examine counter information (such as user PDUs received or user PDUs sent) to determine if port is actively in use.</p>
7	<p>Reenable the transport software that you disabled. If you could not identify any connection problems, repeat this procedure with the transport software that you previously disabled.</p>

7.5.2 Checking NSAP Counters

Do the following to get information about connections between two systems:

Step	Action						
1	<p>Determine the local NSAPs for the system you want to examine. Use one of the following NCL commands:</p> <pre>ncl>show nsp local nsap * name</pre> <pre>ncl>show osi transport local nsap * name</pre> <p>Each transport can have up to three NSAPs.</p>						
2	<p>Determine the remote NSAPs for the system you want to examine. You need to examine all combinations of local and remote NSAPs. Use one or both of the following NCL commands:</p> <pre>ncl> show nsp local nsap nsap-address -</pre> <pre>_ncl>remote nsap * name</pre> <pre>ncl>show osi transport local nsap nsap-address -</pre> <pre>_ncl>remote nsap * name</pre>						
3	<p>Check the counters on the source system. Use one of the following NCL commands:</p> <pre>ncl>show nsp local nsap nsap-address -</pre> <pre>_ncl>remote nsap nsap-address all attributes</pre> <pre>ncl>show osi transport local nsap nsap-address -</pre> <pre>_ncl>remote nsap nsap-address all attributes</pre>						
4	<p>Try to establish a connection to the target system. If you cannot connect to the target system, check the remote system or try to reach the remote system from a different node.</p>						
5	<p>Check the counters on the source system.</p>						
	<table border="1" style="width: 100%;"> <thead> <tr> <th style="text-align: left;">If:</th> <th style="text-align: left;">Then:</th> </tr> </thead> <tbody> <tr> <td style="vertical-align: top;"> <p>The Connects Sent counter increments, the source node initiated a connect request to the target node.</p> </td> <td style="vertical-align: top;"> <p>Do one or both of the following:</p> <ul style="list-style-type: none"> • Check the target node for incoming connections. See step 6 of this procedure. • A network problem can exist. See Chapter 8. </td> </tr> <tr> <td style="vertical-align: top;"> <p>The Connects Sent counter does not increment, either a problem exists on the source system which prevents the system or application from attempting the connection, or a naming service problem exists.</p> </td> <td style="vertical-align: top;"> <p>Do one of the following:</p> <ul style="list-style-type: none"> • Check the application. • Check naming service operation. See your naming service documentation. </td> </tr> </tbody> </table>	If:	Then:	<p>The Connects Sent counter increments, the source node initiated a connect request to the target node.</p>	<p>Do one or both of the following:</p> <ul style="list-style-type: none"> • Check the target node for incoming connections. See step 6 of this procedure. • A network problem can exist. See Chapter 8. 	<p>The Connects Sent counter does not increment, either a problem exists on the source system which prevents the system or application from attempting the connection, or a naming service problem exists.</p>	<p>Do one of the following:</p> <ul style="list-style-type: none"> • Check the application. • Check naming service operation. See your naming service documentation.
If:	Then:						
<p>The Connects Sent counter increments, the source node initiated a connect request to the target node.</p>	<p>Do one or both of the following:</p> <ul style="list-style-type: none"> • Check the target node for incoming connections. See step 6 of this procedure. • A network problem can exist. See Chapter 8. 						
<p>The Connects Sent counter does not increment, either a problem exists on the source system which prevents the system or application from attempting the connection, or a naming service problem exists.</p>	<p>Do one of the following:</p> <ul style="list-style-type: none"> • Check the application. • Check naming service operation. See your naming service documentation. 						

Solving Transport Problems

7.5 Correcting Connection Problems

Step	Action				
6	<p>If the source node is sending outgoing connect requests, check the counters on the target system.</p> <hr/> <table><thead><tr><th>If:</th><th>Then:</th></tr></thead><tbody><tr><td><p>The Connects Received counter increments but connection fails, there is a problem on the target node.</p><p>The Connects Received counter does not increment, a network problem may exist on either system that prevents the connections.</p></td><td><p>Examine the remote node to determine the problem.</p><p>Do any of the following:</p><ul style="list-style-type: none">• Perform network reachability tests (see Chapter 3).• Trace a path from the source node to the target node to determine if all systems in the expected path are available.• Check the appropriate routing circuits and data links (see Chapter 8).</td></tr></tbody></table> <hr/>	If:	Then:	<p>The Connects Received counter increments but connection fails, there is a problem on the target node.</p> <p>The Connects Received counter does not increment, a network problem may exist on either system that prevents the connections.</p>	<p>Examine the remote node to determine the problem.</p> <p>Do any of the following:</p> <ul style="list-style-type: none">• Perform network reachability tests (see Chapter 3).• Trace a path from the source node to the target node to determine if all systems in the expected path are available.• Check the appropriate routing circuits and data links (see Chapter 8).
If:	Then:				
<p>The Connects Received counter increments but connection fails, there is a problem on the target node.</p> <p>The Connects Received counter does not increment, a network problem may exist on either system that prevents the connections.</p>	<p>Examine the remote node to determine the problem.</p> <p>Do any of the following:</p> <ul style="list-style-type: none">• Perform network reachability tests (see Chapter 3).• Trace a path from the source node to the target node to determine if all systems in the expected path are available.• Check the appropriate routing circuits and data links (see Chapter 8).				
7	<p>If you disabled transport entities, re-enable them, after checking the transport connection, with one of the following NCL commands:</p> <pre>ncl>enable nsp ncl>enable osi transport</pre> <hr/>				

7.6 Correcting OSI Transport Over CLNS Connection Problems

Do the following to correct transport problems if you are running OSI transport over CLNS connections:

Step	Action
1	Check the outgoing OSI connection. Use the following NCL command to identify the OSI transport template and network service (CONS or CLNS): <pre>ncl> show osi transport template * all attributes</pre>
2	Check to see if the source node is sending connect requests. Do the following: <ul style="list-style-type: none">• Use CTF to trace OSI transport for outgoing connect requests.• Check the OSI transport local and remote NSAP counters before and after attempting the connection. <p>If connect requests are not being sent, check the application or the Network layer of the source node.</p> <p>If connect requests are being sent, go to the next step in this procedure.</p>
3	Check to see if the destination node is receiving incoming connect requests: <ul style="list-style-type: none">• Use CTF to trace OSI transport for incoming connect requests.• Check OSI local and remote NSAP counters for connects received before and after the connect attempt. <p>If incoming requests are not received, trace the network path between the source and destination node, and check the appropriate routing circuits or data links.</p> <p>If incoming requests are received, go to the next step in this procedure.</p>
4	Check the remote node to determine if an application on the destination node is available to receive connect requests. <ol style="list-style-type: none">a. For OSI applications such as FTAM or Virtual Terminal, refer to the application documentation to check that the application is defined correctly.b. For other applications, use the NCL command <code>show session control application <i>application-id</i> all</code>. For example, to verify the application definition for system operations on an OpenVMS system, enter the following command: <pre>ncl>show session control application fal all</pre><p>Check that the node synonym characteristic is set to true, the image name is <code>sys\$system:fal.exe</code>, and the address is 17. If these values are incorrect, use NCL commands to correct them.</p>

Solving Transport Problems

7.7 Correcting OSI Transport Over CONS (X.25) Connection Problems

7.7 Correcting OSI Transport Over CONS (X.25) Connection Problems

Do the following to correct transport problems if you are running OSI transport over CONS connections:

Step	Action
1	<p>Check that the source node is using a CONS template. Use the following NCL command:</p> <pre>ncl> show osi transport template * all attributes</pre>
2	<p>Check that the CONS template exists. Use the following NCL command:</p> <pre>ncl> show x25 access template <i>template_id</i> - _ncl> all characteristics</pre> <p>If the template does not exist, create the appropriate template (see your DECnet-Plus network management documentation).</p> <p>If the template does exist, go to the next step.</p>
3	<p>Check to see if the source node is sending connect requests. Do one of the following:</p> <ul style="list-style-type: none">• Use CTF to trace OSI transport for outgoing connect requests.• Look at the OSI transport local and remote NSAP counters before and after attempting the connection. <p>If connect requests are not being sent, check the application or the network layer of the source node. See your X.25 documentation for information.</p> <p>If connect requests are being sent, go to the next step in this procedure.</p>
4	<p>Check to see if the destination node is receiving incoming connect requests:</p> <ul style="list-style-type: none">• Use CTF to trace OSI transport for incoming connect requests.• Look at the OSI transport local and remote NSAP counters for connects received before and after the connect attempt. <p>If incoming requests are not received, trace the network path between the source and destination node and check the appropriate routing circuits or data links.</p> <p>If incoming requests are received, go to the next step in this procedure.</p>
5	<p>Determine if an application on the destination node is available to receive connect requests. Do the following:</p> <ul style="list-style-type: none">• For OSI applications such as FTAM or Virtual Terminal, refer to the application documentation to check that the application is defined correctly.• For other applications, use the NCL command <code>show session control application <i>application-id</i> all</code>. For example, to verify the application definition for system operations on a Digital UNIX system, enter the following command: <pre>ncl> show session control application fal all</pre><p>Check that the node synonym characteristic is set to true, the image name is <code>usr/sbin/fal</code>, and the address is <code>number=17</code>. If these values are incorrect, use NCL commands to correct them.</p>

7.8 Troubleshooting RFC 1006

Some general techniques for RFC 1006 troubleshooting include:

- Run the `rfc1006d` daemon in `-debug` mode to obtain printed information messages about the daemon's activities.
- Use the example programs to help you isolate the application behavior that is causing the problem. Use them to test RFC 1006 connectivity with a remote node or the local node.
- During RFC 1006 application debugging, use the example programs as a way to test your assumptions about the behavior of XTI for RFC 1006 and to supplement the documentation.

RFC 1006 is layered on TCP/IP. Refer to your TCP/IP operational information for details.

7.8.1 Common Problems

While troubleshooting, you may encounter these problems:

- **rfc1006d appears to exit as soon as you run it**

Note that `rfc1006d` obeys standard UNIX daemon conventions; therefore, you will see a shell prompt immediately after running the program, even if `rfc1006d` is still running, because `rfc1006d` will run itself as a background process even if not explicitly directed to do so.

To see if it is still running, use this command:

```
# ps -aef | grep rfc1006d
```

If you start an `rfc1006d` process while another `rfc1006d` is already running, an error message will be written into the `syslog` file. The number in square brackets is the process ID. The following is an example of such an error message:

```
Jul 20 16:25:12 itsdoa rfc1006d[408]: t_bind: errno=Address already in use,  
t_errno=System error
```

- **rfc1006d is not running**

Under normal conditions, `rfc1006d` is started up at system boot time by a shell script named `/sbin/rc3.d/S28.70rfc1006`. Make sure that script is present. Run it and see whether `rfc1006d` stays running. Check the system log file for error messages from `rfc1006d`. (Check both `daemon.log` and `kern.log`.)

- **Client cannot connect to server**

Determine if the remote node can be reached by any TCP application. If it cannot, use TCP/IP network troubleshooting techniques.

If the remote node can be reached by a TCP application, make sure that the remote RFC 1006 has a daemon running and listening to the TCP port to which the local node is connected. This port should be port 102 under normal conditions.

Next, make sure that the server application is running and listening for the TSAP-ID in the client's destination RFC 1006 address.

Solving Transport Problems

7.8 Troubleshooting RFC 1006

- **Client gets TSYSEERR value in t_errno variable and ENETDOWN in errno variable**

This error is returned by the kernel to the RFC 1006 application whenever the rfc1006d daemon dies or is not running. Verify that the rfc1006d daemon is running. The TSYERR and ENETDOWN symbols are defined in the <xti.h> and <errno.h> include files respectively.

- **Connections hang**

See if the RFC 1006 kernel is having trouble getting buffer space. You can do this with the command:

```
# dbx -k /vmunix
dbx) p r1006_allocb_failures
0
dbx)
```

This value is normally zero. If it is not zero, either a large number of concurrent RFC 1006 sessions or competition with other streams applications for kernel streams buffer space could be the problem.

- **XTI RFC 1006 application gets TSYSEERR value in t_errno variable and EPROTO value in errno variable**

This means that a protocol error was detected by RFC 1006. A protocol error is an unexpected behavior by either the network or the remote application. An error message containing information about the protocol error should have been logged in the system log file. Forward this information to Digital, along with a method of reproducing the problem or a precise description of what was going on when the problem happened. The TSYERR and EPROTO errors are defined in the <xti.h> and <errno.h> include files respectively.

Solving Network Layer Problems

This chapter describes how to use routing circuit and data link information to isolate and correct simple DECnet-Plus network layer problems.

Topics In This Chapter

The topics in this chapter are:

- Underlying Entities (OpenVMS Only) (Section 8.1)
- Underlying Entities (Digital UNIX Only) (Section 8.2)
- Symptoms of Network Layer Problems (Section 8.3)
- Isolating Network Layer Problems (Section 8.4)
- Finding Underlying Entities (Section 8.5)
- Correcting Configuration Problems (Section 8.6)
- Correcting Connectivity Problems (Section 8.7)

Solving Network Layer Problems

8.1 Underlying Entities (OpenVMS Only)

8.1 Underlying Entities (OpenVMS Only)

To isolate problems at the Network layer, you need to be able to identify the data link entities that the Routing layer uses and the physical entities associated with the data link entities.

Figure 8–1 illustrates the users of the data links that you find in a DECnet-Plus for OpenVMS system.

Solving Network Layer Problems 8.1 Underlying Entities (OpenVMS Only)

Figure 8-1 Underlying Entities (OpenVMS)

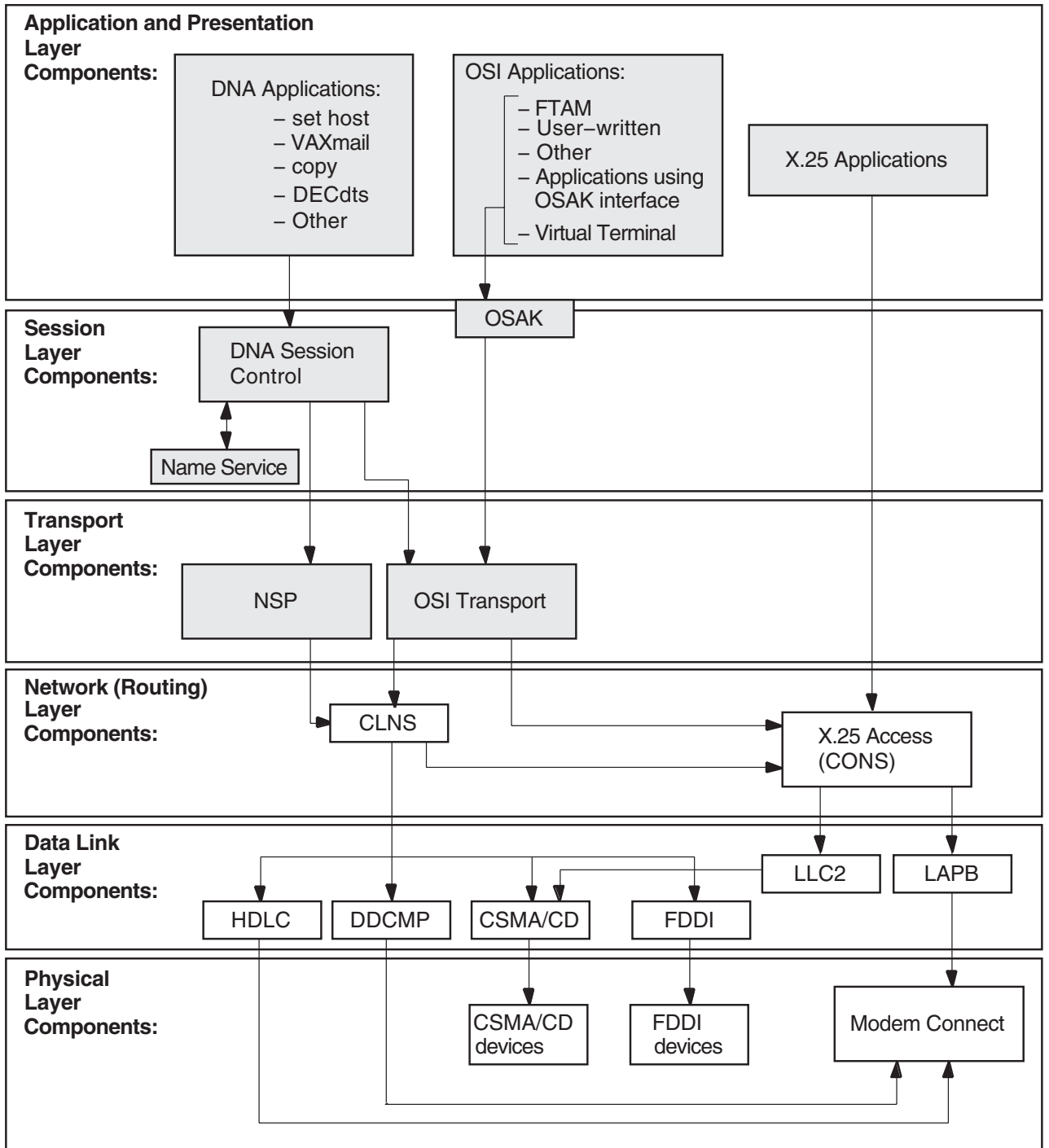

LKG-09685-96R

Solving Network Layer Problems

8.2 Underlying Entities (Digital UNIX Only)

8.2 Underlying Entities (Digital UNIX Only)

To isolate problems at the Network layer, you need to be able to identify the data link entities that the Routing layer uses and the physical entities associated with the data link entities.

Figure 8–2 illustrates the users of the data links that you find in a DECnet-Plus for Digital UNIX system.

Solving Network Layer Problems 8.2 Underlying Entities (Digital UNIX Only)

Figure 8-2 Underlying Entities (Digital UNIX)

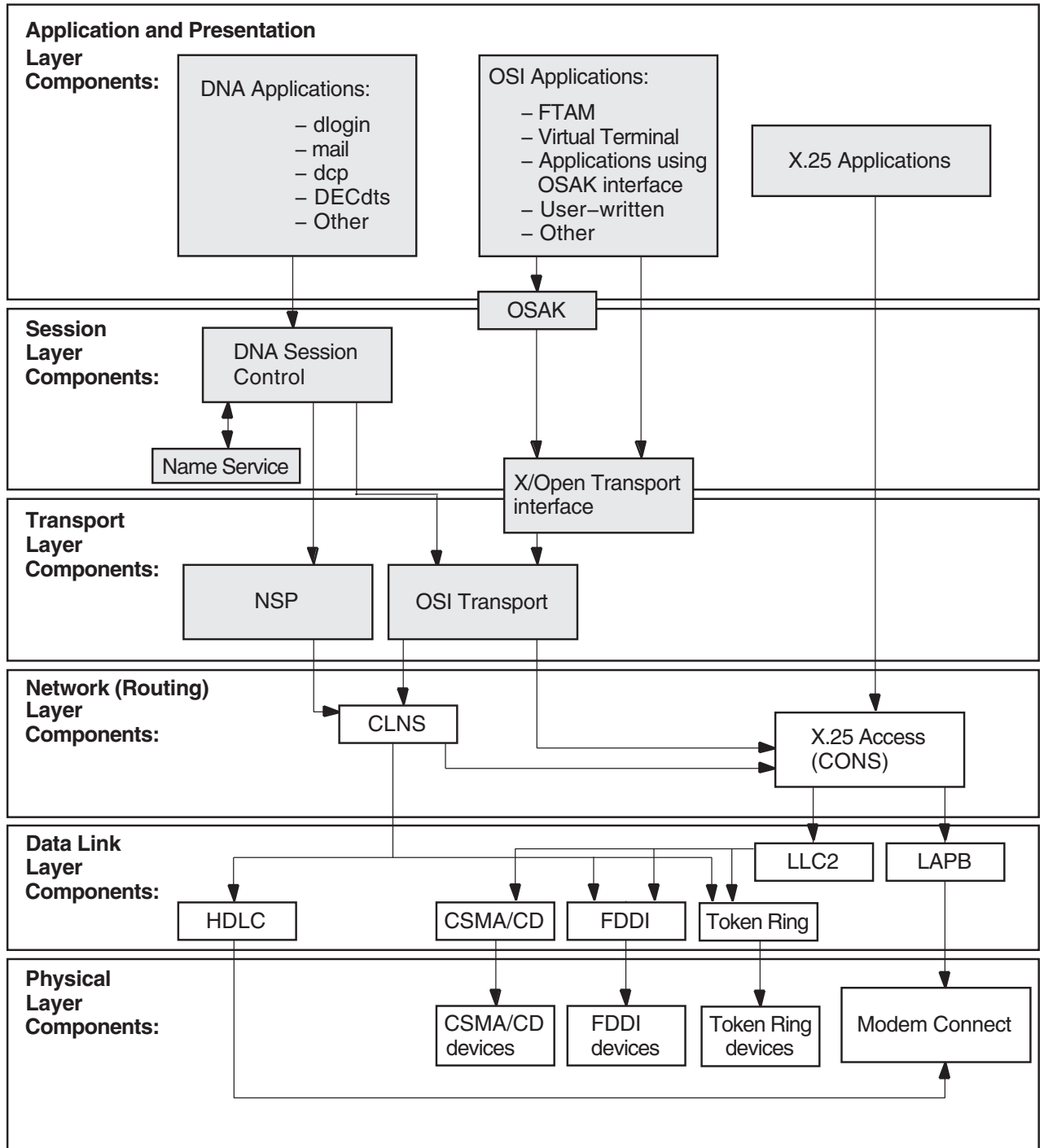

LKG-09686-96R

Solving Network Layer Problems

8.3 Symptoms of Network Layer Problems

8.3 Symptoms of Network Layer Problems

The symptoms in Table 8–1 indicate that a routing-circuit or data link problem exists.

Table 8–1 Symptoms of Network Layer Problems

Symptom	Possible Problem	See
Entities were not available when tracing a path between a routing circuit and the physical device. One or more of the entities had a State characteristic set to off. An error appeared when you tried to enable an entity.	Configuration	Section 8.6
An application failed but no errors were found in the upper layers	Configuration or connectivity	Section 8.6 or 8.7
The configuration is correct but the routing circuit does not work	Connectivity	Section 8.7

8.4 Isolating Network Layer Problems

If you think you have a Network layer problem, first check the physical connections between systems before you examine routing circuits and their underlying entities.

8.4.1 Tools to Use

Use NCL commands to check routing circuits in the Network layer.

Solving Network Layer Problems

8.4 Isolating Network Layer Problems

8.4.2 Fault-Isolation Methodology

Use Figure 8–3 as a guideline when you isolate circuit connectivity and configuration faults. The following sections in this chapter describe related correction procedures.

Figure 8–3 Fault-Isolation Methodology (Circuit Connectivity)

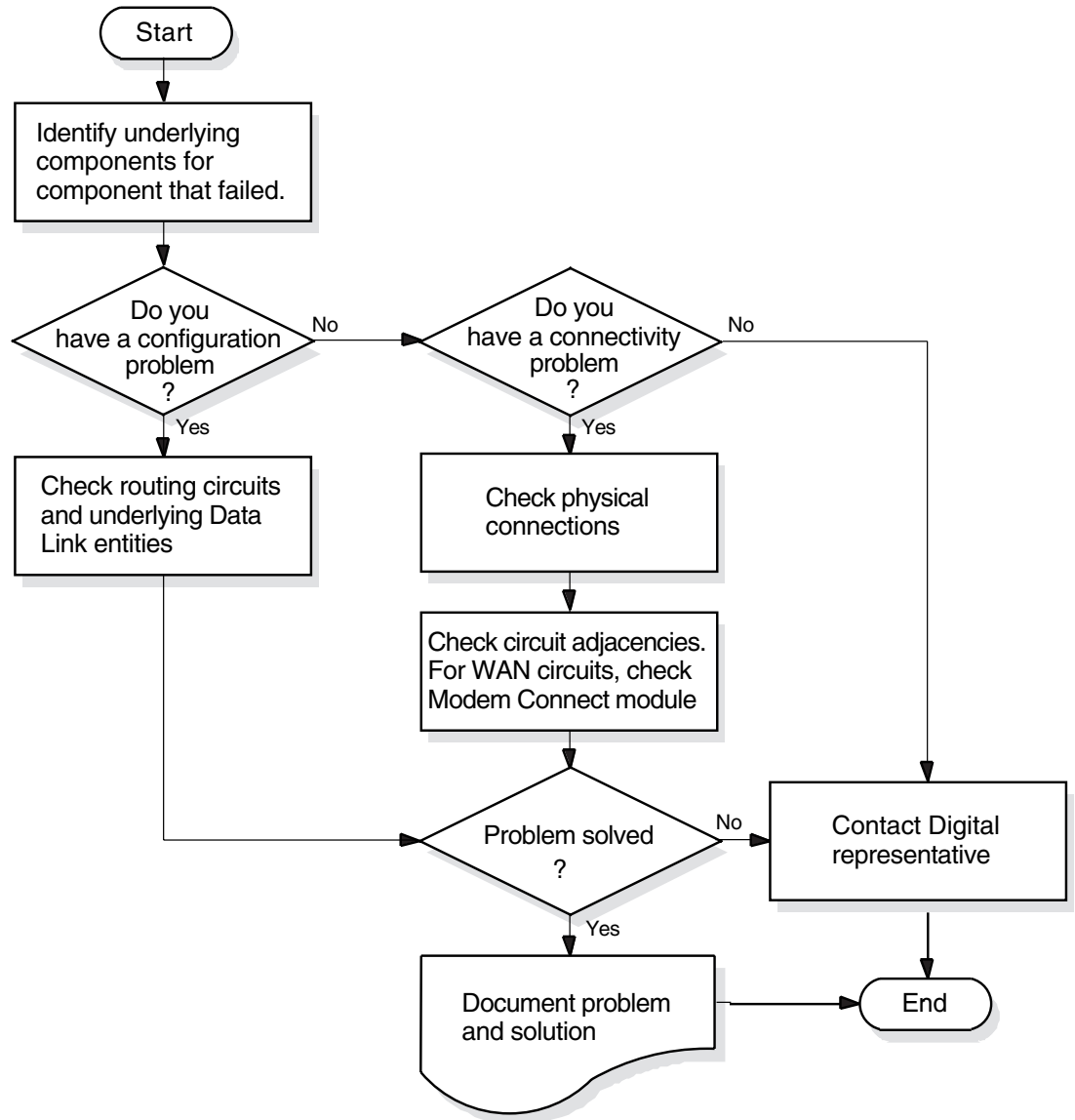

LKG-9035-96R

Solving Network Layer Problems

8.5 Finding Underlying Entities

8.5 Finding Underlying Entities

To isolate routing circuits and data link problems in the Network layer, you need to be able to identify the underlying entities for specific routing circuits.

For each routing circuit type, there is a corresponding data link entity displayed with the set of circuit characteristics. The X.25 Protocol module provides information about the associated data link entities for X.25 circuits. Refer to your NCL and X.25 documentation for more details about X.25 circuits.

8.5.1 Finding the Underlying Entities for HDLC Circuits

If you know the routing circuit ID, you can identify the associated underlying entities, including the physical device entity by doing the following:

Step	Action
1	Set the NCL default entity to the node whose circuits you want to check. If you cannot reach a remote node over the network, log into that system directly to check the circuits.
2	Find the data link entity for the routing circuit that you want to check. Use the following NCL command: <pre>ncl>show routing circuit <i>circuit-id</i> - _ncl>data link entity</pre>
3	Examine the physical line characteristic of the data link entity module. Use the following NCL command: <pre>ncl>show hdlc link <i>link-name</i> logical station</pre>
4	Examine the physical device entity to identify the communications device. Use the following NCL command: <pre>ncl>show modem connect line <i>line-id</i> - _ncl>communications port</pre>

8.5.2 Finding the HDLC Circuits for a Physical Device

If you know the physical device entity, you can identify the associated routing circuit by doing the following:

Step	Action
1	Find the Modem Connect entity connected to the physical device. Use the following NCL command: <pre>ncl>show modem connect line * comm port</pre>
2	Examine the Modem Connect data port entity for the communications port. Use the following NCL command: <pre>ncl>show modem connect data port * all status</pre>
3	Examine the HDLC port entity's attributes for one that contains the same client as displayed in the previous step. The client characteristic indicates the routing circuit. Use the following NCL command: <pre>ncl>show HLDC port * all status</pre>

8.5.3 Finding the Underlying Entities for DDCMP Circuits (OpenVMS Only)

If you know the routing circuit ID, you can identify the associated underlying entities, including the physical device entity by doing the following:

Step	Action
1	Set the NCL default entity to the node whose circuits you want to check. If you cannot reach a remote node over the network, log into that system directly to check the circuits.
2	Find the data link entity for the routing circuit that you want to check. Use the following NCL command: <pre>ncl>show routing circuit <i>circuit-id</i> - _ncl>data link entity</pre>
3	Examine the physical line characteristic of the data link entity module. Use the following NCL command: <pre>ncl>show ddcmp link <i>link-name</i> physical line</pre>
4	Examine the physical device entity to identify the communications device. Use the following NCL command: <pre>ncl>show modem connect line <i>line-id</i> comm port</pre>

8.5.4 Finding the DDCMP Circuits for a Physical Device (OpenVMS Only)

If you know the physical device entity, you can identify the associated routing circuit by doing the following:

Step	Action
1	Find the Modem Connect entity connected to the physical device. Use the following NCL command: <pre>ncl>show modem connect line * comm port</pre>
2	Examine the Modem Connect entity for the communications port. Use the following NCL command: <pre>ncl>show modem connect data port * all status</pre>
3	Examine the DDCMP port entity's attributes for the client characteristic. The client characteristic indicates the routing circuit. Use the following NCL command: <pre>ncl>show DDCMP port * all status</pre>

8.5.5 Finding the Underlying Entities for CSMA-CD Circuits

If you know the routing circuit ID, you can identify the associated underlying entities, including the physical device entity by doing the following:

Step	Action
1	Set the NCL default entity to the node whose circuits you want to check. If you cannot reach a remote node over the network, you need to log into that system directly to check the circuits.
2	Find the data link entity. Use the following NCL command: <pre>ncl>show routing circuit <i>circuit-id</i> - _ncl>data link entity</pre>

Solving Network Layer Problems

8.5 Finding Underlying Entities

Step	Action
3	Examine the communication port characteristic of the data link entity to identify the communications port. Use the following NCL command: <pre>ncl>show csma-cd station <i>station-id</i> comm port</pre>

8.5.6 Finding the CSMA-CD Circuit for a Physical Device

If you know the physical device entity, you can identify the associated routing circuit by doing the following:

Step	Action
1	Find the CSMA-CD station entity connected to the physical device. Use the following NCL command: <pre>ncl>show csma-cd station * comm port</pre>
2	Examine the CSMA-CD port entity's attributes to find the routing circuit. Use the following NCL command: <pre>ncl>show csma-cd port * client, station</pre>

8.5.7 Finding the Underlying Entities for FDDI Circuits

If you know the routing circuit ID, you can identify the associated underlying entities, including the physical device entity by doing the following:

Step	Action
1	Set the NCL default entity to the node whose circuits you want to check. If you cannot reach a remote node over the network, log into that system directly to check the circuits.
2	Find the data link entity for the routing circuit that you want to check. Use the following NCL command: <pre>ncl>show routing circuit <i>circuit-id</i> - _ncl>data link entity</pre>
3	Examine the physical port characteristic of the data link entity to identify the physical port. Use the following NCL command: <pre>ncl>show fddi station <i>station-id</i> - _ncl>communication port</pre>

8.5.8 Finding the FDDI Circuit for a Physical Device

If you know the physical device entity, you can identify the associated routing circuit by doing the following:

Step	Action
1	Find the FDDI station entity connected to the physical device. Use the following NCL command: <pre>ncl>show fddi station * - _ncl>communication port</pre>
2	Examine the FDDI port entity's attributes to find the routing circuit. Use the following NCL command: <pre>ncl>show fddi port * client</pre>

8.5.9 Finding the Underlying Entities for Token Ring Circuits (Digital UNIX Only)

If you know the routing circuit ID, you can identify the associated underlying entities, including the physical device entity by doing the following:

Step	Action
1	Set the NCL default entity to the node whose circuits you want to check. If you cannot reach a remote node over the network, log into that system directly to check the circuits.
2	Find the data link entity for the routing circuit that you want to check. Use the following NCL command: <pre>ncl>show routing circuit <i>circuit-id</i> - _ncl>data link entity</pre>
3	Examine the physical port characteristic of the data link entity to identify the physical port. Use the following NCL command: <pre>ncl>show token ring station <i>station-id</i> - _ncl>communication port</pre>

8.5.10 Finding the Token Ring Circuit for a Physical Device (Digital UNIX Only)

If you know the physical device entity, you can identify the associated routing circuit by doing the following:

Step	Action
1	Find the Token Ring station entity connected to the physical device. Use the following NCL command: <pre>ncl>show token ring station * communication port</pre>
2	Examine the Token Ring port entity's attributes to find the routing circuit. Use the following NCL command: <pre>ncl>show token ring port * client, station</pre>

8.6 Correcting Configuration Problems

If you suspect there is a routing circuit configuration problem, check the routing circuit's state. If `state=off`, use the NCL command `enable` to set the state to `on`.

If:	Then Do This:
Error appears	Check the characteristics of the data link entity associated with the routing circuit.
No error appears	Check that the routing circuit state remains on. For HDLC circuits, if the state does not remain on, the system should generate an event indicating why.

8.6.1 Correcting DDCMP (OpenVMS Only) and HDLC Data Link Configuration Problems

Do the following to correct problems with DDCMP or HDLC data links (only OpenVMS on Alpha systems support DDCMP entities):

1. Check the state of the appropriate link and logical station entities. Use the NCL commands similar to the following (use `ddcmp` instead of `hdlc` only when checking DDCMP entities for OpenVMS):

Solving Network Layer Problems

8.6 Correcting Configuration Problems

```
ncl>show hdlc link link-id state
ncl>show hdlc link link-id logical station station-id
```

- If the `state=off`, use the `enable` command to change the state to `on`.

If:	Then Do This:
Error appears	Check the characteristics of the entity indicated in the error message.
No error appears	Check that the state remains on. For HDLC circuits, if state does not remain on, check the Modem Connect module.

- If the `state=on`, check and record the value of the `protocol state` attribute of the local station entity.

If Attribute Value Is:	Then:
Running	All devices and entities appear to be operating properly.
Starting or Initializing	The data link is attempting to connect with the remote system. If the link remains in this state for a significant amount of time, it could be that the data being transmitted is not received by the remote node. This indicates you have a connectivity problem.
Halted or Inoperative	One of the related entities is disabled. Check the states of the related entities.
Error	The threshold number of attempts to synchronize the link was reached. Check the counters for the logical station entity.

8.6.2 Correcting CSMA-CD Data Link Configuration Problems

Do the following to correct CSMA-CD data link configuration problems:

Step	Action
1	Check that the CSMA-CD station exists. Use the following NCL command: <code>ncl>show csma-cd station <i>station-id</i> state</code>
2	If the device does not exist, issue the appropriate command to create the device (see your installation documentation). If an error appears when you try to create the device, check the entity specified in the message.
3	If the device does exist, check the entity's state. If the state is <code>off</code> , enable the device. If the state is <code>on</code> , and the data link still does not operate correctly, the cause is most likely a connectivity problem.

8.7 Correcting Connectivity Problems

If your configuration seems correct but the routing circuit does not work, it is possible that a connectivity problem is the cause of the failure. Do the following:

Solving Network Layer Problems

8.7 Correcting Connectivity Problems

Step	Action
1	Check the physical connections. For example: <ul style="list-style-type: none">• Check that all cables are connected correctly.• If using a modem, check the indicators to see if they provide any indication of a problem.
2	For WAN links (HDLC), check the Modem Connect status to see if the modem control leads are asserted correctly.
3	Determine if data is being sent and received. You can: <ul style="list-style-type: none">• Check entity Transmit and Receive counters to see if they are incrementing.• If there appear to be no data flows, use loopback tests to see how far data can be transmitted and received.
4	Look to see if circuit adjacencies exist. Use the following NCL command: <code>ncl>show circuit <i>circuit-id</i> * adjacency * all</code>

Using the OSAKtrace Utility

The OSAKtrace utility captures a record of what happens during an OSI information exchange. The OSAKtrace utility is not an implementation of any OSI standard; there is no ISO standard for OSI tracing.

You can use OSAKtrace to show that application programs that use the OSAK routines conform with the standards, and to identify any problems that may arise when one OSI application works with another over a network.

Information on using the OSAKtrace utility appears in *OSAK Programming*, and descriptions of the trace emitter calls appear in *OSAK Programming Reference*.

B

DECnet-Plus Application Tracing Examples

This appendix contains an example of a trace output for the FTAM and Virtual Terminal software.

The trace output for FTAM and Virtual Terminal operations on Digital UNIX and OpenVMS is very similar; this appendix shows the trace output as it appears on a Digital UNIX system.

DECnet-Plus Application Tracing Examples

B.1 DECnet-Plus Application Trace Example

B.1 DECnet-Plus Application Trace Example

This section provides an example of the default output of the `ositrace` utility. This example traces the result of the `FTAM omv` command on a Digital UNIX system.

B.1.1 Association Establishment — Initiator

The initiator requests a session connection.

```
10:11:57.08   OSI trace started Wed Jan 30 10:11:57 1994
10:11:58.20 --> Session
0dff0148 05061301 00160102 14020002 33028080 34020103 c1ff0130 3180a080
80010100 00a28081 02808082 020103a4 80308002 01010605 28c27b02 01308006
02510100 00000030 80020103 060528c2 7b020230 80060251 01000000 00308002
01050605 28c27b02 03308006 02510100 00000030 80020107 060528c2 7b020430
80060251 01000000 00308002 01090606 2bce0f01 02023080 06025101 00000000
30800201 0b060452 01000130 80060251 01000000 00000088 02060089 03054000
61803080 02010ba0 7b6080a1 80060528 c27b0101 0000a280 06052bce 0f070100
00a38002 01010000 be802880 020101a0 4da08082 01008302 03408403 05070085
02058086 0100a780 4e0528c2 7b05014e 0528c27b 05024e05 28c27b05 034e062b
ce0f0105 09000056 0776696e 63656e74 710a1908 6e69636b 73746572 00000000
00000000 00000000 00000000

connect-spdu                                     0d ff 01
  connect/accept-item                             05 06
    protocol-options = NULL                       13 01
    version-number = 2                            16 01 02
  session-user-requirements = '0000000000000010'B 14 02 00
    ( duplex functional unit )
  calling-ssap-identifier =                       33 02 80
  called-ssap-identifier =                        34 02 01
  user-data                                       c1 ff 01
```

Presentation Connection — Initiator

The initiator requests a presentation connection. The negotiation of abstract syntaxes takes place during this time.

```
10:11:58.20 --> Presentation
3180a080 80010100 00a28081 02808082 020103a4 80308002 01010605 28c27b02
01308006 02510100 00000030 80020103 060528c2 7b020230 80060251 01000000
00308002 01050605 28c27b02 03308006 02510100 00000030 80020107 060528c2
7b020430 80060251 01000000 00308002 01090606 2bce0f01 02023080 06025101
00000000 30800201 0b060452 01000130 80060251 01000000 00000088 02060089
03054000 61803080 02010ba0 7b6080a1 80060528 c27b0101 0000a280 06052bce
0f070100 00a38002 01010000 be802880 020101a0 4da08082 01008302 03408403
05070085 02058086 0100a780 4e0528c2 7b05014e 0528c27b 05024e05 28c27b05
034e062b ce0f0105 09000056 0776696e 63656e74 710a1908 6e69636b 73746572
00000000 00000000 00000000 00000000
```

DECnet-Plus Application Tracing Examples

B.1 DECnet-Plus Application Trace Example

```

CP PDU SET =                                     31 80
{
  [0] IMPLICIT SET =                             a0 80
  {
    [0] IMPLICIT mode-selector INTEGER = normal-mode 80 01 01
  }
  [2] IMPLICIT SEQUENCE =                       a2 80
  {
    [1] IMPLICIT calling-presentation-selector OCTET STRING = 81 02
        '8080'H
    [2] IMPLICIT called-presentation-selector OCTET STRING = 82 02
        '0103'H
    [4] IMPLICIT presentation-context-definition-list SEQUENCE = a4 80
    {
      SEQUENCE =                                30 80
      {
        presentation-context-identifier INTEGER = 1      02 01 01
        abstract-syntax-name OBJECT IDENTIFIER =        06 05 28
            {1 0 8571 2 1}
        SEQUENCE =                                    30 80
        {
          transfer-syntax-name OBJECT IDENTIFIER = {2 1 1} 06 02 51
        }
      }
      SEQUENCE =                                    30 80
      {
        presentation-context-identifier INTEGER = 3      02 01 03
        abstract-syntax-name OBJECT IDENTIFIER =        06 05 28
            {1 0 8571 2 2}
        SEQUENCE =                                    30 80
        {
          transfer-syntax-name OBJECT IDENTIFIER = {2 1 1} 06 02 51
        }
      }
      SEQUENCE =                                    30 80
      {
        presentation-context-identifier INTEGER = 5      02 01 05
        abstract-syntax-name OBJECT IDENTIFIER =        06 05 28
            {1 0 8571 2 3}
        SEQUENCE =                                    30 80
        {
          transfer-syntax-name OBJECT IDENTIFIER = {2 1 1} 06 02 51
        }
      }
      SEQUENCE =                                    30 80
      {
        presentation-context-identifier INTEGER = 7      02 01 07
        abstract-syntax-name OBJECT IDENTIFIER =        06 05 28
            {1 0 8571 2 4}
        SEQUENCE =                                    30 80
        {
          transfer-syntax-name OBJECT IDENTIFIER = {2 1 1} 06 02 51
        }
      }
      SEQUENCE =                                    30 80
      {
        presentation-context-identifier INTEGER = 9      02 01 09
        abstract-syntax-name OBJECT IDENTIFIER =        06 06 2b
            {1 3 9999 1 2 2}
        SEQUENCE =                                    30 80
        {
          transfer-syntax-name OBJECT IDENTIFIER = {2 1 1} 06 02 51
        }
      }
    }
  }
}

```

DECnet-Plus Application Tracing Examples

B.1 DECnet-Plus Application Trace Example

```

SEQUENCE = 30 80
{
  presentation-context-identifier INTEGER = 11 02 01 0b
  abstract-syntax-name OBJECT IDENTIFIER = {2 2 1 0 1} 06 04 52
  SEQUENCE = 30 80
  {
    transfer-syntax-name OBJECT IDENTIFIER = {2 1 1} 06 02 51
  }
}
[8] IMPLICIT presentation-requirements BIT STRING = '00'B 88 02 06
( )
[9] IMPLICIT user-session-requirements BIT STRING = 89 03 05
'0100000000'B
( duplex )
[APPLICATION 1] IMPLICIT fully-encoded-data SEQUENCE = 61 80
{
  PDV-list SEQUENCE = 30 80
  {
    presentation-context-identifier INTEGER = 11 02 01 0b
    single-asn1-type [0] ANY = a0 7b

    -- Abstract Syntax Name
    -- ACSE-PCI
    -- Presentation Context Identifier
    -- 11
  }
}

```

ACSE Association Request — Initiator

The initiator requests an ACSE association. The application context is set at this time.

```

10:11:58.20 --> ACSE
6080a180 060528c2 7b010100 00a28006 052bce0f 07010000 a3800201 010000be
80288002 0101a04d a0808201 00830203 40840305 07008502 05808601 00a7804e
0528c27b 05014e05 28c27b05 024e0528 c27b0503 4e062bce 0f010509 00005607
76696e63 656e7471 0a19086e 69636b73 74657200 00000000 00000000 00000000
000000

[APPLICATION 0] IMPLICIT aarq SEQUENCE = 60 80
{
  application-context-name [1] a1 80 06
  application-context-name OBJECT IDENTIFIER =
  {1 0 8571 1 1}
  called-ap-title [2] ap-title OBJECT IDENTIFIER = a2 80 06
  {1 3 9999 7 1}
  called-ae-qualifier [3] ae-qualifier INTEGER = 1 a3 80 02
  [30] IMPLICIT user-information SEQUENCE = be 80
  {
    IMPLICIT EXTERNAL SEQUENCE = 28 80
    {
      indirect-reference INTEGER = 1 02 01 01
      single-asn1-type [0] ANY = a0 4d

      -- Abstract Syntax Name
      -- FTAM-PCI
      -- Presentation Context Identifier
      -- 1
    }
  }
}

```

DECnet-Plus Application Tracing Examples B.1 DECnet-Plus Application Trace Example

FTAM Initialization Request — Initiator

The initiator requests an FTAM initialization to establish the FTAM regime. The negotiating of service class and functional unit, the listing of supported document types, and the passing of the initiator ID and password occur at this time.

```
10:11:58.20 --> FTAM
a0808201 00830203 40840305 07008502 05808601 00a7804e 0528c27b 05014e05
28c27b05 024e0528 c27b0503 4e062bce 0f010509 00005607 76696e63 656e7471
0a19086e 69636b73 74657200 00000000 00000000 00000000 00000000 00000000

[0] IMPLICIT f-initialize-request SEQUENCE =      a0 80
{
  [2] IMPLICIT present-context-management          82 01 00
      BOOLEAN = false
  [3] IMPLICIT service-class BIT STRING =         83 02 03
      '01000'B
      ( management-class )
  [4] IMPLICIT functional-units BIT STRING =      84 03 05
      '00000111000'B
      ( limited-file-management,
        enhanced-file-management,
        grouping )
  [5] IMPLICIT attribute-groups BIT STRING =      85 02 05
      '100'B
      ( storage )
  [6] IMPLICIT ftam-quality-of-service            86 01 00
      INTEGER = no-recovery
  [7] IMPLICIT contents-type-list SEQUENCE =      a7 80
  {
    [APPLICATION 14] IMPLICIT document-type-name 4e 05 28
      OBJECT IDENTIFIER = {1 0 8571 5 1}
      (ftam-1)
    [APPLICATION 14] IMPLICIT document-type-name 4e 05 28
      OBJECT IDENTIFIER = {1 0 8571 5 2}
      (ftam-2)
    [APPLICATION 14] IMPLICIT document-type-name 4e 05 28
      OBJECT IDENTIFIER = {1 0 8571 5 3}
      (ftam-3)
    [APPLICATION 14] IMPLICIT document-type-name 4e 06 2b
      OBJECT IDENTIFIER = {1 3 9999 1 5 9}
      (nbs-9)
  }
  [APPLICATION 22] IMPLICIT initiator-identity   56 07
      GRAPHIC STRING = smith
  filestore-password [APPLICATION 17]           71 0a 19
      GraphicString GRAPHIC STRING = mypassword
}
}
}
}
}
```

DECnet-Plus Application Tracing Examples

B.1 DECnet-Plus Application Trace Example

B.1.2 Association Establishment — Responder

The peer FTAM application response indicates that the session connect request is accepted.

```
10:11:58.70 <-- Session
0ee40506 13010016 01021402 00023402 0103c1d2 3180a080 80010100 00a280a5
80308080 01008102 51010000 30808001 00810251 01000030 80800100 81025101
00003080 80010081 02510100 00308080 01008102 51010000 30808001 00810251
01000000 00880206 00890305 40006180 30800201 0ba06761 80a18006 0528c27b
01010000 a2030201 00a305a1 03020100 be802880 020101a0 3fa18080 02078082
01008302 03408403 05070085 02058086 0100a780 4e0528c2 7b05014e 062bce0f
0105094e 0528c27b 05034e05 28c27b05 02000088 01010000 00000000 00000000
00000000 0000

accept-spdu                                0e e4
  connect/accept-item                       05 06
    protocol-options = NULL                 13 01
    version-number = 2                      16 01 02
  session-user-requirements = '000000000000010'B 14 02 00
    ( duplex functional unit )
  called-ssap-identifier =                  34 02 01
  user-data                                  c1 d2
```

Presentation Connect Request — Responder

The responder accepts the presentation connection request and notifies the requestor of the status of the negotiated abstract and transfer syntaxes.

```
10:11:58.70 <-- Presentation
3180a080 80010100 00a280a5 80308080 01008102 51010000 30808001 00810251
01000030 80800100 81025101 00003080 80010081 02510100 00308080 01008102
51010000 30808001 00810251 01000000 00880206 00890305 40006180 30800201
0ba06761 80a18006 0528c27b 01010000 a2030201 00a305a1 03020100 be802880
020101a0 3fa18080 02078082 01008302 03408403 05070085 02058086 0100a780
4e0528c2 7b05014e 062bce0f 0105094e 0528c27b 05034e05 28c27b05 02000088
01010000 00000000 00000000 00000000 0000

cpa-ppdu SET =                               31 80
{
  [0] IMPLICIT SET =                           a0 80
  {
    [0] IMPLICIT mode-selector INTEGER = normal-mode 80 01 01
  }
  [2] IMPLICIT SEQUENCE =                       a2 80
  {
    [5] IMPLICIT presentation-context-definition-result-list
    SEQUENCE =                                  a5 80
    {
      SEQUENCE =                                30 80
      {
        [0] IMPLICIT result INTEGER = acceptance 80 01 00
        [1] IMPLICIT transfer-syntax-name OBJECT IDENTIFIER = 81 02 51
            {2 1 1}
      }
      SEQUENCE =                                30 80
      {
        [0] IMPLICIT result INTEGER = acceptance 80 01 00
        [1] IMPLICIT transfer-syntax-name OBJECT IDENTIFIER = 81 02 51
            {2 1 1}
      }
    }
    SEQUENCE =                                  30 80
    {
      [0] IMPLICIT result INTEGER = acceptance 80 01 00
      [1] IMPLICIT transfer-syntax-name OBJECT IDENTIFIER = 81 02 51
          {2 1 1}
    }
  }
}
```

DECnet-Plus Application Tracing Examples

B.1 DECnet-Plus Application Trace Example

```

SEQUENCE =                                     30 80
{
  [0] IMPLICIT result INTEGER = acceptance      80 01 00
  [1] IMPLICIT transfer-syntax-name OBJECT IDENTIFIER = 81 02 51
        {2 1 1}
}
SEQUENCE =                                     30 80
{
  [0] IMPLICIT result INTEGER = acceptance      80 01 00
  [1] IMPLICIT transfer-syntax-name OBJECT IDENTIFIER = 81 02 51
        {2 1 1}
}
SEQUENCE =                                     30 80
{
  [0] IMPLICIT result INTEGER = acceptance      80 01 00
  [1] IMPLICIT transfer-syntax-name OBJECT IDENTIFIER = 81 02 51
        {2 1 1}
}
}
[8] IMPLICIT presentation-requirements BIT STRING = '00'B 88 02 06
( )
[9] IMPLICIT user-session-requirements BIT STRING =      89 03 05
'0100000000'B
( duplex )
[APPLICATION 1] IMPLICIT fully-encoded-data SEQUENCE = 61 80
{
  PDV-list SEQUENCE =                             30 80
  {
    presentation-context-identifier INTEGER = 11      02 01 0b
    single-asn1-type [0] ANY =                      a0 67

    -- Abstract Syntax Name
    -- ACSE-PCI
    -- Presentation Context Identifier
    -- 11
  }
}

```

ACSE Association Request Accepted — Responder

The peer application accepts the ACSE association request.

```

10:11:58.70 <-- ACSE
6180a180 060528c2 7b010100 00a20302 0100a305 a1030201 00be8028 80020101
a03fa180 80020780 82010083 02034084 03050700 85020580 860100a7 804e0528
c27b0501 4e062bce 0f010509 4e0528c2 7b05034e 0528c27b 05020000 88010100
00000000 00000000 00000000 00000000

[APPLICATION 1] IMPLICIT aare SEQUENCE =           61 80
{
  application-context-name [1]                     a1 80 06
    application-context-name OBJECT IDENTIFIER =
      {1 0 8571 1 1}
  result [2] associate-result INTEGER = accepted    a2 03 02
  result-source-diagnostic [3] acse-service-user [1] a3 05 a1
    INTEGER INTEGER = null
  [30] IMPLICIT user-information SEQUENCE =         be 80
  {
    IMPLICIT EXTERNAL SEQUENCE =                   28 80
    {
      indirect-reference INTEGER = 1                 02 01 01
      single-asn1-type [0] ANY =                     a0 3f

      -- Abstract Syntax Name
      -- FTAM-PCI
      -- Presentation Context Identifier
      -- 1
    }
  }
}

```

DECnet-Plus Application Tracing Examples

B.1 DECnet-Plus Application Trace Example

Initialization Request Accepted — Responder

The peer application accepts the FTAM initialization request by sending an F-INITIALIZE response. If the state and action results are absent, then success is the default.

```
10:11:58.70 <-- FTAM
a1808002 07808201 00830203 40840305 07008502 05808601 00a7804e 0528c27b
05014e06 2bce0f01 05094e05 28c27b05 034e0528 c27b0502 00008801 01000000
00000000 00000000 00000000 00

[1] IMPLICIT f-initialize-response SEQUENCE = a1 80
{
[0] IMPLICIT protocol-version BIT STRING = 80 02 07
'1'B
( version-1 )
[2] IMPLICIT present-context-management BOOLEAN = 82 01 00
BOOLEAN = false
[3] IMPLICIT service-class BIT STRING = 83 02 03
'01000'B
( management-class )
[4] IMPLICIT functional-units BIT STRING = 84 03 05
'00000111000'B
( limited-file-management,
enhanced-file-management,
grouping )
[5] IMPLICIT attribute-groups BIT STRING = 85 02 05
'100'B
( storage )
[6] IMPLICIT ftam-quality-of-service INTEGER = 86 01 00
INTEGER = no-recovery
[7] IMPLICIT contents-type-list SEQUENCE = a7 80
{
[APPLICATION 14] IMPLICIT document-type-name 4e 05 28
OBJECT IDENTIFIER = {1 0 8571 5 1}
(ftam-1)
[APPLICATION 14] IMPLICIT document-type-name 4e 06 2b
OBJECT IDENTIFIER = {1 3 9999 1 5 9}
(nbs-9)
[APPLICATION 14] IMPLICIT document-type-name 4e 05 28
OBJECT IDENTIFIER = {1 0 8571 5 3}
(ftam-3)
[APPLICATION 14] IMPLICIT document-type-name 4e 05 28
OBJECT IDENTIFIER = {1 0 8571 5 2}
(ftam-2)
}
[8] IMPLICIT checkpoint-window INTEGER = 1 88 01 01
}
}
}
}
}
}
```

Passing User Data — Initiator

Session and presentation protocol data units (PDUs) carry the FTAM PDUs.

```
10:11:59.05 --> Session
01000100 61803080 020101a0 07b68080 01030000 00003080 020101a0 19a68073
80a08019 07657861 6d706c65 00000000 43020002 00000000 30800201 01a01db0
806880a0 80190f72 656e616d 65645f65 78616d70 6c650000 00000000 00003080
020101a0 04a88000 00000030 80020101 a004b880 00000000 0000

data-spdu 01 00
give-tokens-spdu 01 00
```

DECnet-Plus Application Tracing Examples B.1 DECnet-Plus Application Trace Example

```

10:11:59.05 --> Presentation
61803080 020101a0 07b68080 01030000 00003080 020101a0 19a68073 80a08019
07657861 6d706c65 00000000 43020002 00000000 30800201 01a01db0 806880a0
80190f72 656e616d 65645f65 78616d70 6c650000 00000000 00003080 020101a0
04a88000 00000030 80020101 a004b880 00000000 0000

[APPLICATION 1] IMPLICIT fully-encoded-data SEQUENCE =          61 80
{
  PDV-list SEQUENCE =                                          30 80
  {
    presentation-context-identifier INTEGER = 1                02 01 01
    single-asn1-type [0] ANY =                                a0 07

    -- Abstract Syntax Name
    --   FTAM-PCI
    -- Presentation Context Identifier
    --   1
  }
}

```

FTAM PDUs Grouping

The FTAM PDUs are packaged inside one P-DATA through grouping by the F-BEGIN-GROUP and F-END-GROUP primitives. The virtual filestore actions requested are selecting a file, renaming the file, and deselecting the file.

```

10:11:59.05 --> FTAM
b6808001 03000000 00308002 0101a019 a6807380 a0801907 6578616d 706c6500
00000043 02000200 00000030 80020101 a01db080 6880a080 190f7265 6e616d65
645f6578 616d706c 65000000 00000000 00308002 0101a004 a8800000 00003080
020101a0 04b88000 00000000 00

    [22] IMPLICIT f-begin-group-request SEQUENCE =          b6 80
    {
      [0] IMPLICIT threshold INTEGER = 3                      80 01 03
    }
  }
  PDV-list SEQUENCE =                                          30 80
  {
    presentation-context-identifier INTEGER = 1                02 01 01
    single-asn1-type [0] ANY =                                a0 19

    -- Abstract Syntax Name
    --   FTAM-PCI
    -- Presentation Context Identifier
    --   1
  }
}

```

```

10:11:59.05 --> FTAM
a6807380 a0801907 6578616d 706c6500 00000043 02000200 00000030 80020101
a01db080 6880a080 190f7265 6e616d65 645f6578 616d706c 65000000 00000000
00308002 0101a004 a8800000 00003080 020101a0 04b88000 00000000 00

```

DECnet-Plus Application Tracing Examples

B.1 DECnet-Plus Application Trace Example

```

[6] IMPLICIT f-select-request SEQUENCE =          a6 80
{
  [APPLICATION 19] IMPLICIT attributes SEQUENCE = 73 80
  {
    [0] IMPLICIT select-attributes SEQUENCE =     a0 80
    {
      filename-attribute GRAPHIC STRING = example 19 07
    }
  }
  [APPLICATION 3] IMPLICIT requested-access BIT STRING = 43 02 00
  '00000010'B
  ( change-attributes )
}
}
PDV-list SEQUENCE =                              30 80
{
  presentation-context-identifier INTEGER = 1     02 01 01
  single-asn1-type [0] ANY =                     a0 1d
  -- Abstract Syntax Name
  -- FTAM-PCI
  -- Presentation Context Identifier
  -- 1
}

10:11:59.05 --> FTAM
b0806880 a080190f 72656e61 6d65645f 6578616d 706c6500 00000000 00000030
80020101 a004a880 00000000 30800201 01a004b8 80000000 00000000
[16] IMPLICIT f-change-attributes-request SEQUENCE = b0 80
{
  [APPLICATION 8] IMPLICIT attributes SEQUENCE = 68 80
  {
    [0] IMPLICIT filename SEQUENCE =             a0 80
    {
      filename-attribute GRAPHIC STRING = renamed_example 19 0f
    }
  }
}
}
PDV-list SEQUENCE =                              30 80
{
  presentation-context-identifier INTEGER = 1     02 01 01
  single-asn1-type [0] ANY =                     a0 04
  -- Abstract Syntax Name
  -- FTAM-PCI
  -- Presentation Context Identifier
  -- 1
}

10:11:59.05 --> FTAM
a8800000 00003080 020101a0 04b88000 00000000 00
[8] IMPLICIT f-deselect-request SEQUENCE =       a8 80
{
}
}
PDV-list SEQUENCE =                              30 80
{
  presentation-context-identifier INTEGER = 1     02 01 01
  single-asn1-type [0] ANY =                     a0 04
  -- Abstract Syntax Name
  -- FTAM-PCI
  -- Presentation Context Identifier
  -- 1
}

```

DECnet-Plus Application Tracing Examples

B.1 DECnet-Plus Application Trace Example

```
10:11:59.05 --> FTAM
      b8800000 00000000
          [24] IMPLICIT f-end-group-request SEQUENCE =          b8 80
          {
          }
      }
```

B.1.3 Passing User Data — Responder

Session and presentation protocol data units (PDUs) carry the FTAM PDUs.

```
10:11:59.42 <-- Session
      01000100 61803080 020101a0 04b78000 00000030 80020101 a028a780 7380a080
      191a2f75 73722f75 73657273 2f76696e 63656e74 2f657861 6d706c65 00000000
      00000000 30800201 01a01db1 806880a0 80190f72 656e616d 65645f65 78616d70
      6c650000 00000000 00003080 020101a0 04a98000 00000030 80020101 a004b980
      00000000 0000
      data-spdu                                          01 00
      give-tokens-spdu                                  01 00
```

```
10:11:59.42 <-- Presentation
      61803080 020101a0 04b78000 00000030 80020101 a028a780 7380a080 191a2f75
      73722f75 73657273 2f76696e 63656e74 2f657861 6d706c65 00000000 00000000
      30800201 01a01db1 806880a0 80190f72 656e616d 65645f65 78616d70 6c650000
      00000000 00003080 020101a0 04a98000 00000030 80020101 a004b980 00000000
      0000
      [APPLICATION 1] IMPLICIT fully-encoded-data SEQUENCE =          61 80
      {
      PDV-list SEQUENCE =          30 80
      {
      presentation-context-identifier INTEGER = 1          02 01 01
      single-asnl-type [0] ANY =          a0 04
      -- Abstract Syntax Name
      -- FTAM-PCI
      -- Presentation Context Identifier
      -- 1
```

Sending Responses to Requests — Responder

The FTAM responder sends one response for each of the requests that the initiator sent. Each response must be successful or the whole group fails. Since the state and action results are not present, the default of success is assumed.

```
10:11:59.42 <-- FTAM
      b7800000 00003080 020101a0 28a78073 80a08019 1a2f7573 722f7573 6572732f
      76696e63 656e742f 6578616d 706c6500 00000000 00000030 80020101 a01db180
      6880a080 190f7265 6e616d65 645f6578 616d706c 65000000 00000000 00308002
      0101a004 a9800000 00003080 020101a0 04b98000 00000000 00
          [23] IMPLICIT f-begin-group-response SEQUENCE =          b7 80
          {
          }
      }
      PDV-list SEQUENCE =          30 80
      {
      presentation-context-identifier INTEGER = 1          02 01 01
      single-asnl-type [0] ANY =          a0 28
      -- Abstract Syntax Name
      -- FTAM-PCI
      -- Presentation Context Identifier
      -- 1
```

DECnet-Plus Application Tracing Examples B.1 DECnet-Plus Application Trace Example

```
-- Abstract Syntax Name
--   FTAM-PCI
-- Presentation Context Identifier
--   1

10:11:59.42 <-- FTAM
    b9800000 00000000

        [25] IMPLICIT f-end-group-response SEQUENCE =          b9 80
        {
        }
    }
```

Association Termination — Initiator

The initiator requests the termination of the FTAM regime. Session sends a finish-spdu, ACSE sends an association release request, and FTAM sends an F-TERMINATE request.

```
10:11:59.53 --> Session
    092a1101 01c12561 80308002 010ba018 62808001 00be8028 80020101 a004a280
    00000000 00000000 00000000

    finish-spdu                                               09 2a
        transport-disconnect = '00000001'B                    11 01 01
            ( transport connection is released )
        user-data                                             c1 25
```

```
10:11:59.53 --> Presentation
    61803080 02010ba0 18628080 0100be80 28800201 01a004a2 80000000 00000000
    00000000 00

    [APPLICATION 1] IMPLICIT fully-encoded-data SEQUENCE =    61 80
    {
        PDV-list SEQUENCE =                                    30 80
        {
            presentation-context-identifier INTEGER = 11      02 01 0b
            single-asn1-type [0] ANY =                          a0 18

            -- Abstract Syntax Name
            --   ACSE-PCI
            -- Presentation Context Identifier
            --   11
```

```
10:11:59.53 --> ACSE
    62808001 00be8028 80020101 a004a280 00000000 00000000 00000000

    [APPLICATION 2] IMPLICIT rlrq-ppdu SEQUENCE =             62 80
    {
        [0] IMPLICIT reason INTEGER = normal                   80 01 00
        [30] IMPLICIT user-information SEQUENCE =              be 80
        {
            IMPLICIT EXTERNAL SEQUENCE =                       28 80
            {
                indirect-reference INTEGER = 1                  02 01 01
                single-asn1-type [0] ANY =                       a0 04

                -- Abstract Syntax Name
                --   FTAM-PCI
                -- Presentation Context Identifier
                --   1
```

DECnet-Plus Application Tracing Examples

B.1 DECnet-Plus Application Trace Example

```

10:11:59.53 --> FTAM
a2800000 00000000 00000000 0000
    [2] IMPLICIT f-terminate-request SEQUENCE =          a2 80
    {
    }
  }
}

```

Association Termination — Responder

The responder sends a response for each of the initiator's requests. Session sends a disconnect-spdu, ACSE sends an association release response, and FTAM sends an F-TERMINATE response.

```

10:11:59.65 <-- Session
0a27c125 61803080 02010ba0 18638080 0100be80 28800201 01a004a3 80000000
00000000 00000000 00
  disconnect-spdu          0a 27
  user-data                c1 25

10:11:59.65 <-- Presentation
61803080 02010ba0 18638080 0100be80 28800201 01a004a3 80000000 00000000
00000000 00
  [APPLICATION 1] IMPLICIT fully-encoded-data SEQUENCE =      61 80
  {
  PDV-list SEQUENCE =          30 80
  {
  presentation-context-identifier INTEGER = 11              02 01 0b
  single-asn1-type [0] ANY =    a0 18
  -- Abstract Syntax Name
  -- ACSE-PCI
  -- Presentation Context Identifier
  -- 11

10:11:59.65 <-- ACSE
63808001 00be8028 80020101 a004a380 00000000 00000000 00000000
  [APPLICATION 3] IMPLICIT rlre-ppdu SEQUENCE =              63 80
  {
  [0] IMPLICIT reason INTEGER = normal                      80 01 00
  [30] IMPLICIT user-information SEQUENCE =                  be 80
  {
  IMPLICIT EXTERNAL SEQUENCE =                              28 80
  {
  indirect-reference INTEGER = 1                             02 01 01
  single-asn1-type [0] ANY =                                a0 04
  -- Abstract Syntax Name
  -- FTAM-PCI
  -- Presentation Context Identifier
  -- 1

10:11:59.65 <-- FTAM
a3800000 00000000 00000000 0000

```

DECnet-Plus Application Tracing Examples B.1 DECnet-Plus Application Trace Example

```
      [3] IMPLICIT f-terminate-response SEQUENCE =          a3 80
      {
      }
    }
  }
}
10:11:59.77  OSI trace ended Wed Jan 30 10:11:59 1994
```

A

- Access control rejected, 2-2, 6-6
- Address in use (Digital UNIX), 5-19
- An FTAM file does not have the expected attributes, 5-6
- Application cannot connect to remote OSI system, 5-6
- Application connection fails, 7-6, 8-6
- Application failed, 2-2
- Application too busy, 2-2, 6-6
 - correcting, 6-11
- Applications using OSAK, 5-1
 - correcting connection problems, 5-26
 - correcting problems, 5-26
 - correcting programming problems, 5-27
 - correcting unexpected termination problems, 5-27
 - fault isolation, 5-8
 - fault-isolation tools, 5-8
 - problem symptoms, 5-6
 - related documentation, 5-8
 - underlying components (Digital UNIX) (figure), 5-4
 - underlying components (OpenVMS Only) (figure), 5-2

C

- Circuit adjacencies, 2-7
 - finding, 2-7
- Circuit-level loopback tests, 3-7
 - assistance command parameters, 3-12
 - Assistant address command example, 3-12
 - Assistant system command example, 3-12
 - command parameters, 3-10
 - example, 3-11
 - figure, 3-7
 - full assistance (figure), 3-12
 - identifying node addresses, 3-8
 - preparation example, 3-9
 - preparing for, 3-8
 - receive assistance (figure), 3-13
 - running, 3-10
 - running with assistance, 3-11
 - starting test with assistance, 3-11
 - transmit assistance (figure), 3-13

- Circuit-level loopback tests (cont'd)
 - using assistance for fault isolation, 3-11
 - when to use assistance, 3-11
- Component relationships, 1-4
 - Digital UNIX (figure), 1-6
 - OpenVMS (figure), 1-4
- Configuration problems, 8-11
 - correcting, 8-11
 - correcting CSMA-CD data link problems, 8-12
 - correcting DDCMP and HDLC data link problems, 8-11
- Connect tests, 3-18
 - command example, 3-19
 - command syntax, 3-18
 - running, 3-18
- Connection refused (Digital UNIX), 5-20
- Connection timed out (Digital UNIX), 5-20
- Connectivity problems, 8-12
 - correcting, 8-12

D

- Data tests, 3-19
 - command example, 3-20
 - command syntax, 3-19
 - echo test, 3-19
 - pattern test, 3-19
 - running, 3-19
 - sequence test, 3-19
 - sink test, 3-19
- DECnet-Plus application connection attempts fail, 2-2
- DECnet-Plus application using OSAK fails, 5-6
- DECnet-Plus applications, 5-1
 - correcting FTAM problems (Digital UNIX), 5-19
 - correcting general FTAM connection problems, 5-18
 - correcting problems with application using OSAK, 5-26
 - correcting Virtual Terminal problems (Digital UNIX), 5-19
 - event logging and log files, 5-9
 - fault isolation, 5-8
 - fault-isolation tools, 5-8
 - FTAM fault isolation with management tools (OpenVMS Only), 5-10
 - ositrace utility, 5-11

DECnet-Plus applications (cont'd)

- problem, 5-6
 - problem symptoms (OpenVMS only), 5-7
 - related documentation, 5-8
 - tracing example, B-2
 - tracing examples, B-1
 - tracing overview, 5-11
 - underlying components (figure), 5-2
- ## DECnet-Plus problems, 1-8
- fault-isolation processes, 1-8
 - network model (figure), 1-2
 - problem categories, 1-4
 - symptom table, 2-2
- ## DECnet/OSI applications
- problem symptoms (Digital UNIX only), 5-7
 - underlying components (figure), 5-4
- ## decnet_migrate tool, 2-5
- ## decnet_register tool, 6-16
- ## Disconnect tests, 3-21
- abort with received connect user data, 3-21
 - abort with standard user data, 3-21
 - abort without user data, 3-21
 - command example, 3-22
 - command syntax, 3-21
 - disconnect with standard user data, 3-21
 - running, 3-21
 - with received connect user data, 3-21
 - without data, 3-21
- ## DNA functions, 1-3
- ## dts/dtr tests, 3-3, 3-15
- command syntax, 3-16
 - command syntax conventions, 3-17
 - connect test command example, 3-19
 - connect test command syntax, 3-18
 - data test command example, 3-20
 - data test command syntax, 3-19
 - disconnect test command example, 3-22
 - disconnect test command syntax, 3-21
 - disconnect tests, 3-21
 - interrupt test command example, 3-23
 - interrupt test command syntax, 3-22
 - interrupt tests, 3-22
 - running, 3-15
 - running connect tests, 3-18
 - running data tests, 3-19
 - starting, 3-15
 - types, 3-15
 - using command procedures, 3-17

E

- Entity not available when tracing a network path, 2-2, 8-6
- Event logging, 5-9
 - FTAM and Virtual Terminal (OpenVMS Only), 5-9
 - OpenVMS Only, 5-9

F

- ## Fault isolation, 1-1
- categorizing problems, 1-4
 - component relationships (Digital UNIX) (figure), 1-6
 - component relationships (OpenVMS) (figure), 1-4
 - considerations for intermittent problems, 1-10
 - considerations for reproducible problems, 1-10
 - DECnet-Plus applications, 5-8
 - DECnet-Plus environment considerations, 1-8
 - DECnet-Plus network model, 1-2
 - documenting the process, 1-10
 - intermittent problems, 1-4
 - methodology (figure), 1-8
 - methods, 1-8
 - network layer methodology, 8-7
 - questions to ask, 1-8
 - reproducible problems, 1-4
 - Session Control methodology, 6-8
 - symptom table, 2-2
 - transient problems, 1-4
 - Transport layer methodology, 7-7
- ## Finding circuit adjacencies, 2-7
- ## FTAM, 5-1
- checking foreign filename formats, 5-17
 - correcting connection problems (Digital UNIX), 5-19
 - correcting environment problems (OpenVMS Only), 5-21
 - correcting file problems, 5-17
 - correcting file-handling problems, 5-17
 - correcting general connection problems, 5-18
 - correcting network connection problems, 5-22
 - correcting physical and data link problems, 5-22
 - correcting presentation problems (OpenVMS only), 5-26
 - correcting responder problems (Digital UNIX), 5-21
 - correcting responder problems (OpenVMS Only), 5-20
 - correcting session problems (OpenVMS only), 5-25
 - correcting target SAP connection problems, 5-22
 - correcting transport problems, 5-25
 - event logging (OpenVMS Only), 5-9
 - event logging and log files, 5-9
 - fault isolation, 5-8
 - fault-isolation tools, 5-8
 - generating readable trace file, 5-12
 - IEEE 802 network connection problems (OpenVMS only), 5-23
 - IEEE 802 subnetwork connection problems (OpenVMS only), 5-24

FTAM (cont'd)

- Internet connection problems (OpenVMS only), 5-23
 - management tools (OpenVMS only), 5-10
 - OpenVMS responder log file, 5-9
 - set up, 5-9
 - ositrace command options (Digital UNIX), 5-12
 - problem symptoms, 5-6
 - problem symptoms (Digital UNIX only), 5-7
 - problem symptoms (OpenVMS only), 5-7
 - reading trace files, 5-14
 - related documentation, 5-8
 - security information, 5-11
 - solving application problems, 5-16
 - tracing, 5-11
 - tracing example, B-2
 - tracing overview, 5-11
 - underlying components (figure), 5-2, 5-4
 - X.25 network connection problems (OpenVMS Only), 5-23
 - X.25 subnetwork connection problems (OpenVMS only), 5-24
- FTAM file does not look correct, 2-2
- FTAM responder fails, 2-2, 5-6

I

- IEEE 802 direct access, 5-23
 - FTAM connection problems (OpenVMS only), 5-23
- IEEE 802 subnetwork access, 5-24
 - FTAM connection problems (OpenVMS only), 5-24
- Insufficient resource problems, 6-14
 - correcting, 6-14
- Intermittent problems, 1-4, 1-10
- Internet access, 5-23
 - FTAM connection problems (OpenVMS only), 5-23
- Interrupt tests, 3-22
 - command example, 3-23
 - command syntax, 3-22
 - echo test, 3-22
 - pattern test, 3-22
 - running, 3-22
 - sequence test, 3-22
 - sink test, 3-22

L

- LAN loopback tests, 3-14
 - command parameters, 3-14
 - determining LLC types on remote node, 3-15
 - with LLC messages, 3-14
- Local-to-Local node loopback tests, 3-4
 - figure, 3-5
 - log files, 3-5

- Local-to-Remote node loopback tests, 3-5
 - analyzing results, 3-5
 - figure, 3-6
- Log files, 5-9
 - FTAM and Virtual Terminal, 5-9
- Loopback tests, 3-2
 - circuit level, 3-7
 - node-level, 3-4
 - running node-level tests, 3-6
 - running with assistance, 3-11
 - using on Phase IV nodes, 3-3

M

- Management tools, 5-10

N

- Name Service problems, 6-15
- Network entity titles, 2-9
- Network is unreachable (Digital UNIX), 5-20
- Network layer, 8-1
 - correcting configuration problems, 8-11
 - correcting connectivity problems, 8-12
 - fault-isolation methodology, 8-7
 - finding CSMA-CD circuit underlying entities, 8-9
 - finding CSMA-CD circuits for a physical device, 8-10
 - finding DDCMP circuit underlying entities (OpenVMS only), 8-9
 - finding DDCMP circuits for a physical device (OpenVMS only), 8-9
 - finding FDDI circuit underlying entities, 8-10
 - finding FDDI circuits for a physical device, 8-10
 - finding HDLC circuit underlying entities, 8-8
 - finding HDLC circuits for a physical device, 8-8
 - finding token ring circuit underlying entities, 8-11
 - finding token ring circuits for a physical device, 8-11
 - finding underlying entities, 8-8
 - isolating problems, 8-6
 - problems symptoms, 8-6
 - tools for fault isolation, 8-6
 - underlying entities (OpenVMS Only)(figure), 8-2, 8-4
- Network model, 1-2
 - DNA functions, 1-3
 - figure, 1-2
 - OSI functions, 1-2
 - TCP/IP interoperability, 1-3
- Network path, 2-3, 2-8
 - converting NSAP addresses to Phase IV format, 2-10
 - converting Phase IV address to NSAPs, 2-9

Network path (cont'd)

- determining network entity titles, 2-9
 - determining node addresses for node names, 2-9
 - needed information, 2-8
 - NSAP IV address conversion example, 2-10
 - Phase IV address conversion example, 2-9
 - tracing a DECnet-Plus path, 2-10
 - tracing a mixed environment path, 2-12
 - tracing a path, 2-10
 - X.25 DA network path considerations, 2-12
- ## Network reachability, 3-1
- dts/dtr tests, 3-3, 3-15
 - loopback tests, 3-2
 - node-level loopback tests, 3-4
 - OSI ping, 3-3
 - types of tests, 3-2
- ## Network topology, 2-3
- dechnet_migrate tool, 2-5
 - method for understanding, 2-5
 - references, 2-5
 - when to use dechnet_migrate, 2-5

Node name validation, 6-14

correcting, 6-14

Node names, 2-6

- determining node addresses, 2-9
- identifying, 2-6
- recognizing, 2-6

Node synonyms, 2-6

Node-level loopback tests, 3-4

- analyzing local-to-local test results, 3-4
- analyzing local-to-remote test results, 3-5
- command parameters, 3-6
- example, 3-7
- local-to-local node log files, 3-5
- local-to-local node loopback test (figure), 3-5
- local-to-remote loopback test (figure), 3-6
- running tests, 3-6
- when to use, 3-4

NSAP addresses, 2-9

- converting to Phase IV format, 2-10
- creating from Phase IV address, 2-9
- Phase IV address conversion example, 2-9, 2-10

NSAP counters, 7-9

O

Object is unknown at remote node, 2-2, 6-6

Operating system, 2-6

- finding type and version, 2-6

OSAK

- tracing information, A-1

OSAKtrace

- examples, A-1
- utility, A-1

OSI Echo Function (OSI ping), 3-3

- command syntax, 3-3

restrictions, 3-4

OSI functions, 1-2

OSI transport, 7-11

- CONS problems, 7-12

correcting CLNS problems, 7-11

RFC 1006, 7-13

ositrace utility, 5-11

- command options, 5-12

command syntax, 5-12

reading trace files, 5-14

sample FTAM trace file, B-2

P

Phase IV addresses, 2-9

- converting to NSAP, 2-9

creating from NSAP, 2-10

NSAP conversion example, 2-9

Phase IV node synonyms, 2-3

- finding, 2-6

recognizing, 2-6

Ping, 3-3

Problem categories, 1-4

- intermittent, 1-4

reproducible, 1-4

transient, 1-4

Problem solving, 2-1

- converting NSAP addresses to Phase IV format, 2-10

converting Phase IV address to NSAPs, 2-9

definitions, 2-3

determining network entity titles, 2-9

determining node addresses for node names, 2-9

finding operating system and version, 2-6

getting circuit information, 2-7

needed information, 2-3

network paths, 2-8

NSAP address conversion example, 2-10

Phase IV address conversion example, 2-9

preparing for, 2-1

recognizing node names and synonyms, 2-6

tools to use, 2-3

tracing a DECnet-Plus network path, 2-10

tracing a mixed environment network path, 2-12

tracing a network path, 2-10

understanding network topology, 2-5

useful network path information, 2-8

X.25 DA network path considerations, 2-12

Proxy access, 6-12

correcting (Digital UNIX Only), 6-13

correcting (OpenVMS), 6-12

R

- Remote node is shutting down, 2-2
- Remote node is unreachable, 2-2, 6-6
- Reproducible problems, 1-4, 1-10
- RFC 1006
 - troubleshooting, 7-13
- Routing circuit does not work, 2-2
- Routing circuit is configured correctly but fails, 8-6
- Routing circuits, 2-3, 2-7
 - finding circuit adjacencies, 2-7
 - finding names, types, and states, 2-7
 - getting information, 2-7
 - useful information, 2-7
- Running dts/dtr tests, 3-15

S

- Search path, 6-15
 - tracing, 6-15
- Session Control, 6-1
 - application too busy, 6-11
 - correcting timed out problems, 6-15
 - Digital UNIX proxy access, 6-13
 - fault isolation, 6-7
 - fault-isolation methodology (figure), 6-8
 - fault-isolation tools and commands, 6-7
 - insufficient resource problems, 6-14
 - node name validation, 6-14
 - OpenVMS proxy access correction procedure, 6-12
 - problem symptoms, 6-6
 - related documentation, 6-5
 - underlying components (figure), 6-4
 - underlying components (OpenVMS)(figure), 6-2
 - unknown application, 6-10
- Session Control has insufficient resources, 2-2, 6-6
- Symptom table, 2-2

T

- TCP/IP
 - troubleshooting using DECnet, 4-2
- Timed out, 2-2, 6-6, 7-6
 - correcting, 6-15
- Tracing, 6-15
 - DECnet-Plus network path, 2-10
 - examples, B-1
 - file, 5-11
 - FTAM example, B-2
 - generating a DECnet-Plus application readable trace file, 5-12
 - mixed environment network path, 2-12
 - network path, 2-10

Tracing (cont'd)

- ositrace command options (Digital UNIX), 5-12
 - ositrace utility, 5-11
 - overview, 5-11
 - reading trace file, 5-14
 - security information, 5-11
 - X.25 DA network path considerations, 2-12
- Transient problems, 1-4
 - Transport layer, 7-1
 - checking NSAP counters, 7-9
 - correcting connection problems, 7-8
 - checking ports, 7-8
 - correcting OSI transport over CLNS problems, 7-11
 - correcting OSI transport over CONS problems, 7-12
 - fault-isolation methodology (figure), 7-7
 - fault-isolation tools, 7-6
 - isolating problems, 7-6
 - problem symptoms, 7-6
 - troubleshooting RFC 1006, 7-13
 - underlying components (Digital UNIX Only) (figure), 7-4
 - underlying components (OpenVMS Only) (figure), 7-2

U

- Unable to communicate with DECdns server, 2-2
- Unknown application, 6-10
 - at remote node, 2-2, 6-6
- User-written application fails, 2-2
- User-written application problem affects OSAK, 2-2, 5-6
- User-written DECnet-Plus application terminates unexpectedly, 2-3, 5-6

V

- Virtual Terminal, 5-1
 - correcting connection problems (Digital UNIX), 5-19
 - event logging (OpenVMS Only), 5-9
 - event logging and log files, 5-9
 - fault isolation, 5-8
 - fault-isolation tools, 5-8
 - generating readable trace file, 5-12
 - ositrace command options (Digital UNIX), 5-12
 - problem symptoms, 5-6
 - problem symptoms (Digital UNIX only), 5-7
 - problem symptoms (OpenVMS only), 5-7
 - reading trace files, 5-14
 - related documentation, 5-8
 - responder problems (Digital UNIX), 5-21
 - responder problems (OpenVMS Only), 5-20
 - security information, 5-11
 - tracing, 5-11
 - tracing example, B-2

Virtual Terminal (cont'd)
tracing overview, 5-11
underlying components (Digital UNIX) (figure),
5-4
underlying components (OpenVMS Only)
(figure), 5-2
Virtual Terminal responder fails, 2-2, 5-6

W

Wrong information displayed, 2-3, 6-6

X

X.25 access, 5-23
FTAM connection problems (OpenVMS Only),
5-23
X.25 subnetwork access, 5-24
FTAM connection problems (OpenVMS only),
5-24