

Indigo²™ Workstation Owner's Guide

Document Number 007-9096-050

CONTRIBUTORS

Written by Karin Borda, Judy Muchowski and Amy Smith
Illustrated by Maria Mortati and Dany Galgani
Production by Cindy Stief

© 1996, Silicon Graphics, Inc.— All Rights Reserved

The contents of this document may not be copied or duplicated in any form, in whole or in part, without the prior written permission of Silicon Graphics, Inc.

RESTRICTED RIGHTS LEGEND

Use, duplication, or disclosure of the technical data contained in this document by the Government is subject to restrictions as set forth in subdivision (c) (1) (ii) of the Rights in Technical Data and Computer Software clause at DFARS 52.227-7013 and/or in similar or successor clauses in the FAR, or in the DOD or NASA FAR Supplement. Unpublished rights reserved under the Copyright Laws of the United States. Contractor/manufacturer is Silicon Graphics, Inc., 2011 N. Shoreline Blvd., Mountain View, CA 94043-1389.

Silicon Graphics, IRIS, and the Silicon Graphics logo are registered trademarks, and Indigo Magic, IRIS InSight, and IRIX are trademarks of Silicon Graphics, Inc. Macintosh and ImageWriter are registered trademarks of Apple Computer, Inc. Spaceball is a trademark of Spatial Systems, Inc. UNIX is a registered trademark in the United States and other countries, licensed exclusively through X/Open Company, Ltd. PS/2 is a registered trademark of International Business Machines Corporation.

Contents

List of Figures ix

List of Tables xv

- 1. Introduction** 3
 - Finding the Information You Need 4
 - Indigo² Workstation Owner's Guide 5
 - Software Installation Administrator's Guide 5
 - IRIS InSight Online Documentation and Help 5
 - Conventions 6
 - Where to Go from Here 7
- 2. Getting Started** 11
 - Selecting a Site 12
 - Checking Your Shipment 12
 - About the CD Software Media 14
 - Putting the Pieces Together 14
 - Installing the System Disk, Any Internal Drives, and Additional Memory 14
 - Setting Up the System 20
 - Connecting the Monitor, Keyboard, Mouse, and Microphone 22
 - Attaching the Ethernet Cable 25
 - Attaching an Ethernet AUI Cable 26
 - Attaching an Ethernet 10-BASE T Cable 27
 - Attaching the Power Cables 28
 - Turning On the Indigo² Workstation 30
 - Logging In to the Workstation 31
 - Creating Your Login Account and Network Connection 32

- Using the Indigo Magic User Environment 35
 - Mouse Techniques and Shortcuts 35
 - The Desktop and the Icons 36
 - Console Window 37
 - The Toolchest 37
 - IRIS InSight and Online Help 38
- Shutting Down and Powering Off Your Indigo² Workstation 39
 - Using the Power Switch to Shut Down the System 39
 - Using the Toolchest to Shut Down the System 41
- Locking Your Indigo² Workstation 44
- 3. Installing and Removing Memory 49**
 - Installing Memory 49
 - Shutting Down and Powering Off the System 50
 - Removing the Cover 50
 - Installing the SIMMs 51
 - Replacing the Cover 54
 - Checking New Memory 55
 - Removing Memory 57
 - Shutting Down the System 57
 - Removing the Cover 58
 - Locating the Memory SIMMs 60
 - Removing the 5-1/4" Drive Tray 60
 - Removing the Memory SIMMs 63
 - Replacing the 5-1/4" Drive Tray 64
 - Replacing the Cover 65
- 4. Installing and Removing EISA Boards 69**
 - Installing EISA Boards 69
 - Shutting Down and Powering Off the System 69
 - Removing the Cover 70
 - Installing the EISA Board 71
 - Replacing the Cover 74

Removing EISA Boards	75
Shutting Down and Powering Off the System	76
Removing the Cover	76
Removing the EISA Board	77
Replacing the Cover	79
5. Installing Peripherals	83
Installing an Internal Drive	83
Shutting Down and Powering Off the System	84
Removing the Front Bezel	84
Installing the Drive	85
Replacing the Cover and Turning On the Power	86
Testing the Internal Drive	88
If You Installed a CD-ROM Drive	88
If You Installed a Floppy or Floptical Disk Drive	89
Ejecting a Floppy or Floptical Disk	89
If You Installed a Tape Drive	89
Cleaning DAT Drives	90
Removing Internal Drives	90
Installing External SCSI Devices	90
Assigning a SCSI Address to the External Device	91
Setting the SCSI Address on the External Device	91
Attaching the Device	92
Testing the External Device	97
If You Installed a Floppy or Floptical Drive	98
If You Installed a CD-ROM Drive	98
If You Installed a Tape Drive	99
If You Installed a Printer	99

- Installing Serial Devices 100
 - Attaching the Device 100
 - Configuring the Device 102
 - Other Serial Cables 102
 - Printer/Dumb Terminal Serial Cable 102
 - Modem Cable 103
 - Serial Devices Using a Silicon Graphics Adapter Cable 104
 - Serial Devices Using a PC Adapter Cable 105
- Installing Audio Devices 106
- 6. Installing Software 109**
 - About the Software Installation Tools 109
 - Installing a New Version of the Operating System Software 110
 - Choosing Subsystems to Install or Remove 115
 - Troubleshooting Software Installation 119
 - System Cannot Find the New Software 119
 - System Cannot Complete an Installation 120
 - System Reports Errors After an Installation 121
- 7. Troubleshooting 125**
 - Diagnosing Hardware Problems 125
 - Power-on Tests 126
 - No Visible Light from the LED with No Error Message 127
 - A Blinking Amber LED with No Error Message 128
 - A Blinking Amber LED with an Error Message 128
 - A Solid Amber LED with No Error Message 130
 - A Solid Amber LED with an Error Message 130
 - Green LED but the Keyboard Doesn't Work 133
 - Green LED but the Mouse Doesn't Work 133
 - Interactive Diagnostic Environment (IDE) Tests 133

Confidence Tests	137
Audio	138
Dial and Button, Tablet, Genlock, and Spaceball	139
CD-ROM Drive	139
Floppy Drive	141
Keyboard	142
Monitor	143
Mouse	144
Quarter Inch Tape and Digital Audio Tape Drives	144
Recovering from a System Crash	145
Disabling the System Maintenance Password	150
Service and Support Information	152
8. Ordering, Removing, and Installing Replacement Parts	155
Ordering Replacement Parts	156
Replacing Internal Parts	157
Shutting Down the System	157
Removing the Cover	158
Attaching the Wrist Strap	159
Replacing the Part	159
Replacing the Graphics Board Set	160
Removing and Replacing the XZ or Extreme Graphics Board Set	161
Removing and Replacing the XL Board	165
Replacing the CPU Module	169
Replacing the Power Supply	176
Checking and Replacing Faulty SIMMs	183
Replacing Internal Drives	184
Replacing the CPU Baseboard	185
Replacing the Cover	200
Replacing External Parts	202
Shutting Down and Powering Off the System	202
Replacing the Keyboard or Mouse	202
Replacing External SCSI Devices	203

- 9. Safety, Maintenance, and Regulatory Information 207**
 - Maintaining Your Hardware and Software 207
 - Hardware Do's and Don'ts 207
 - Software Do's and Don'ts 208
 - Human Factors Guidelines for Setting up Your Indigo² Workstation 209
 - ANSI Standard for Visual Display Terminal (VDT) Workstations 209
 - Computer Aided Design (CAD) Operator Preferences 212
 - Tips for Setting Up and Using Your Workstation 213
 - Facilities Selection 213
 - Adjusting Your Chair, Work Surface, and Indigo² 213
 - Workstation Usage 214
 - Manufacturer's Regulatory Declarations 215
 - Manufacturer's Declaration of Conformity 215
 - Electromagnetic Emissions 216
 - Radio and Television Interference 217
 - Shielded Cables 218
 - Electrostatic Discharge 218
 - Limited User Warranty 219
- A. Cable Pinout Assignments 223**
 - Serial Ports 224
 - Parallel Port 225
 - Ethernet 10-BASE T 227
 - Ethernet AUI 228
 - Keyboard 229
 - Mouse 230
 - SCSI Port 231
 - Audio 233
- B. International Keyboard Support 237**
 - Glossary 241**
 - Index 257**

List of Figures

Figure 1-1	Sources of Information for the Indigo ² Workstation	4
Figure 1-2	Workstation Owner's Guide	5
Figure 1-3	Software Installation Guide	5
Figure 1-4	IRIS InSight Icon	6
Figure 2-1	Indigo ² Parts	13
Figure 2-2	Opening the Front Cover of the Indigo ² Chassis	15
Figure 2-3	Removing the Front Bezel From the Indigo ² Chassis	16
Figure 2-4	Installing the System Disk	17
Figure 2-5	Installing an Option Drive	18
Figure 2-6	Replacing the Front Bezel on the Indigo ² Chassis	19
Figure 2-7	Placing the Monitor on Top of the Indigo ² Workstation	20
Figure 2-8	Attaching the Workstation Stand to the System	21
Figure 2-9	Connecting the Monitor Cable to the Indigo ² Chassis	22
Figure 2-10	Connecting the Keyboard Cable to the Indigo ² Chassis	23
Figure 2-11	Connecting the Mouse Cable to the Indigo ² Chassis	24
Figure 2-12	Connecting the Microphone to the Indigo ² Chassis	25
Figure 2-13	Ethernet AUI Port on the Back of the Indigo ² Chassis	26
Figure 2-14	Connecting the Standard Ethernet Cable	27
Figure 2-15	Attaching an Ethernet 10-BASE T Cable to the Indigo ² Chassis	27
Figure 2-16	Attaching the Power Cable to the Monitor	28
Figure 2-17	Attaching the Power Cable to the Indigo ² Chassis	29
Figure 2-18	Turning on the Indigo ² Workstation	30
Figure 2-19	Running the Power-On Diagnostics Notifier	30
Figure 2-20	System Startup Notifier	31
Figure 2-21	System is Coming Up Notifier	31
Figure 2-22	The Login Screen	32
Figure 2-23	The EZsetup Screen	33

Figure 2-24	Desktop Icons	36
Figure 2-25	CD Player Icon	37
Figure 2-26	The Minimized Console Window	37
Figure 2-27	The Toolchest	38
Figure 2-28	IRIS InSight Icon	38
Figure 2-29	Opening the Front Cover	39
Figure 2-30	Pressing and Releasing the Power Switch	40
Figure 2-31	System Power Off Notifier	40
Figure 2-32	The Toolchest	41
Figure 2-33	System Shutdown Caution Message	42
Figure 2-34	System Shutdown Notifier	42
Figure 2-35	Okay to Power Off Notifier	43
Figure 2-36	Starting Up the System Notifier	43
Figure 2-37	Installing the Lockbar	44
Figure 2-38	Locking the Indigo ² Workstation	45
Figure 3-1	Removing the Front Bezel From the Indigo ² Chassis	50
Figure 3-2	Removing the Top Cover From the Indigo ² Chassis	51
Figure 3-3	Locating the SIMM Sockets	52
Figure 3-4	Orienting the SIMM When Facing the Rear of the Chassis	53
Figure 3-5	Tilting the SIMM up to a Vertical Position	53
Figure 3-6	Replacing the Top Cover on the Indigo ² Chassis	54
Figure 3-7	Replacing the Front Bezel on the Indigo ² Chassis	55
Figure 3-8	System Startup Notifier	56
Figure 3-9	System is Coming up Notifier	56
Figure 3-10	Removing the Front Bezel from the Indigo ² Chassis	58
Figure 3-11	Removing the Top Cover From the Indigo ² Chassis	59
Figure 3-12	Locating the Memory SIMMs	60
Figure 3-13	Loosening the Screws on the 5-1/4" Drive Tray	61
Figure 3-14	Removing the 5-1/4" Drive Tray From the Indigo ² Chassis	62
Figure 3-15	Removing a SIMM	63
Figure 3-16	Replacing the 5-1/4" Drive Tray in the Indigo ² Chassis	64
Figure 3-17	Replacing the Top Cover on the Indigo ² Chassis	65
Figure 3-18	Replacing the Front Bezel on the Indigo ² Chassis	66

Figure 4-1	Removing the Front Bezel from the Indigo ² Chassis	70
Figure 4-2	Removing the Top Cover From the Indigo ² Chassis	70
Figure 4-3	Locating the EISA Slots	71
Figure 4-4	Opening the Metal Panel in Front of the EISA Slots	72
Figure 4-5	Installing the EISA Board	73
Figure 4-6	Closing the Metal Panel in Front of the EISA Slots	74
Figure 4-7	Replacing the Top Cover of the Indigo ² Chassis	74
Figure 4-8	Replacing the Front Bezel on the Indigo ² Chassis	75
Figure 4-9	Removing the Front Bezel From the Indigo ² Chassis	76
Figure 4-10	Removing the Top Cover From the Indigo ² Chassis	77
Figure 4-11	Opening the Metal Panel in Front of the Expansion Slots	78
Figure 4-12	Removing the EISA Board From the Indigo ² Chassis	78
Figure 4-13	Replacing the Top Cover on the Indigo ² Chassis	79
Figure 4-14	Replacing the Front Bezel on the Indigo ² Chassis	80
Figure 5-1	Removing the Front Bezel From the Indigo ² Chassis	84
Figure 5-2	Locating the Drive Slots in the Front of the Chassis	85
Figure 5-3	Installing an Internal Drive	86
Figure 5-4	Replacing the Top Cover on the Indigo ² Chassis	87
Figure 5-5	Replacing the Front Bezel on the Indigo ² Chassis	87
Figure 5-6	Removing the Terminator From the Indigo ² Workstation	93
Figure 5-7	Removing the Terminator From the Last Device on the Daisy-Chain	94
Figure 5-8	Connecting an External SCSI Device to the Indigo ² Chassis	94
Figure 5-9	Daisy-chaining an External SCSI Device to Another External SCSI Device	95
Figure 5-10	Attaching a Terminator to an External SCSI Device	96
Figure 5-11	Connecting the Power Cable to an External Device	96
Figure 5-12	CD-ROM Icon	98
Figure 5-13	Locating the Serial Ports on the Back of the Indigo ² Chassis	100
Figure 5-14	Connecting the Serial Cable to the Serial Port on the Indigo ² Workstation	101
Figure 5-15	Connecting an Audio Device to the Indigo ² Workstation	106
Figure 7-1	System Shutdown Caution Notifier	134
Figure 7-2	System Shutdown Notifier	134

Figure 7-3	Okay to Power Off Notifier	135
Figure 7-4	Pressing the Reset Button	135
Figure 7-5	Starting up the System Notifier	136
Figure 7-6	Confidence Tests Form	138
Figure 7-7	Audio Confidence Test Form	139
Figure 7-8	Keyboard Test	142
Figure 7-9	Pressing the Reset Button	146
Figure 7-10	System Startup Notifier	146
Figure 7-11	System Recovery Menu	147
Figure 7-12	Media Request Notifier	147
Figure 7-13	Enter Password Prompt	150
Figure 7-14	Locating the Password Jumper	151
Figure 7-15	Disabled Password Notifier	151
Figure 8-1	Removing the Front Cover From the Indigo ² Chassis	158
Figure 8-2	Removing the Front Bezel From the Indigo ² Chassis	158
Figure 8-3	Removing the Top Cover From the Indigo ² Chassis	159
Figure 8-4	Lowering the Metal Panel in Front of the Expansion Slots	161
Figure 8-5	Removing the Screws From the Metal Extension	162
Figure 8-6	Pulling the Board Set out of the Chassis	163
Figure 8-7	Replacing the Graphics Board Set	164
Figure 8-8	Opening the Metal Panel in Front of the Expansion Slots	165
Figure 8-9	Removing the Screw From the Metal Extension	166
Figure 8-10	Orientation of the Wrenches	167
Figure 8-11	Removing the XL Board From the Chassis	167
Figure 8-12	Replacing the XL Graphics Board in the Chassis	168
Figure 8-13	Loosening the Screws on the 5-1/4" Drive Tray	169
Figure 8-14	Removing the 5-1/4" Drive Tray From the Indigo ² Chassis	170
Figure 8-15	Removing the R4000 CPU Module	171
Figure 8-16	Removing the R4400 150 MHz CPU Module	172
Figure 8-17	Removing the R4400 200 MHz CPU Module	173
Figure 8-18	Removing the R4600 133 MHz CPU Module	174
Figure 8-19	Replacing the 5-1/4" Drive Tray	175
Figure 8-20	Removing the Power Supply Screw	176

Figure 8-21	Disconnecting the SCSI Cable from the 5-1/4" Drive Tray	177
Figure 8-22	Removing the 5-1/4" Drive Tray From the Indigo ² Chassis	178
Figure 8-23	Locating the Three Power Supply Cables	179
Figure 8-24	Moving the Power Supply Toward the Front of the Chassis	180
Figure 8-25	Removing the Power Supply From the Indigo ² Chassis	180
Figure 8-26	Connecting the Power Cable Located Close to the Disk Drives	181
Figure 8-27	Installing the Power Supply	182
Figure 8-28	Connecting the Power Cables	183
Figure 8-29	Loosening the Screws on the 5-1/4" Drive Tray	185
Figure 8-30	Removing the 5-1/4" Drive Tray	186
Figure 8-31	Lowering the Metal Panel in Front of the Expansion Slots	187
Figure 8-32	Removing the Screws From the Graphics Board Set	188
Figure 8-33	Removing the XZ or Extreme Graphics Board Set	189
Figure 8-34	Orientation of the Wrenches	190
Figure 8-35	Removing the XL Graphics Board	190
Figure 8-36	Removing the EISA Board Backplane From the Indigo ² Chassis	191
Figure 8-37	Removing the R4400 150 MHz CPU Module From the CPU Baseboard	192
Figure 8-38	Disconnecting the Cables From the CPU Baseboard	193
Figure 8-39	Removing the Screws From the Back of the Chassis	194
Figure 8-40	Installing the CPU Baseboard in the Indigo ² Chassis	195
Figure 8-41	Installing the R4400 150 MHz CPU Module in the Indigo ² Chassis	196
Figure 8-42	Installing the EISA Board Backplane in the Indigo ² Chassis	197
Figure 8-43	Installing the Graphics Board Set in the Indigo ² Chassis	198
Figure 8-44	Installing the 5-1/4" Drive Tray in the Indigo ² Chassis	199
Figure 8-45	Replacing the Top Cover on the Indigo ² Chassis	200
Figure 8-46	Replacing the Front Bezel on the Indigo ² Chassis	201
Figure 9-1	Basic Parameters of VDT Workstation Adjustment (Adapted From ANSI/HFS 100-1988)	211
Figure A-1	Serial Port Pinout Assignments	224
Figure A-2	Serial Port Pinout Assignments	225
Figure A-3	Parallel Port Pinout Assignments	227
Figure A-4	Ethernet 10-BASE T Port Pinout Assignments	228

Figure A-5	Ethernet AUI Port Pinout Assignments	229
Figure A-6	Keyboard Port Pinout Assignments	230
Figure A-7	Mouse Port Pinout Assignments	230
Figure A-8	SCSI Port Pinout Assignments	233
Figure B-1	Opening the Door on the Front of the Indigo ² Workstation	237
Figure B-2	Turning on the Indigo ² Workstation	238
Figure B-3	System Startup Notifier	238
Figure B-4	Keyboard Layout Form	239

List of Tables

Table 5-1	Cable Connector Pinout Assignments for Printer/Dumb Terminal Serial Cable	102
Table 5-2	Cable Connector Pin Assignments for a Modem Cable	103
Table 5-3	Cable Connector Pinout Assignments for the Silicon Graphics Adapter Cable	104
Table 5-4	Cable Connector Pinout Assignments for the PC Adapter Cable	105
Table 7-1	Troubleshooting Symptoms and Probable Causes	126
Table 9-1	ANSI/HFS 100-1988 Guidelines for VDT Workplace Adjustment	210
Table 9-2	Workstation Adjustments Preferred by CAD Users	212
Table A-1	4D Compatible Pin Assignments (RS-232)	224
Table A-2	Macintosh SE Compatible Pin Assignments (RS-422)	224
Table A-3	Parallel Port (25-pin DSUB Connector)	225
Table A-4	Ethernet 10-BASE T Port	227
Table A-5	Ethernet AUI Port (Thicknet)	228
Table A-6	Keyboard Port (6-pin MINIDIN)	229
Table A-7	Mouse Port (6-pin MINIDIN)	230
Table A-8	SCSI Port	231
Table A-9	Audio Ports	233
Table B-1	Keyboard Layout Language Choices	240

Introduction

This chapter explains where to find the information you need to set up and use your Indigo² workstation. It explains when to use this manual, and when to use the online documentation and help.

Introduction

Welcome to the Indigo²[™] workstation. The *Indigo² Workstation Owner's Guide* is your complete guide to installing, diagnosing, and repairing your Indigo² workstation. Specifically, it tells you how to:

- set up your Indigo² workstation and turn it on
- install and remove memory SIMMs
- install and remove EISA boards
- install peripherals
- install and remove software
- diagnose hardware problems
- replace faulty parts
- correctly maintain your workstation

Refer to this guide to set up the system, install hardware options, or find a solution when you suspect there is a hardware problem. Basic information on installing software is also included. For more advanced information on installing software, refer to the *Software Installation Administrator's Guide*.

The system and all the procedures in this guide are designed so that you may maintain and repair the system without the help of a trained technician. However, do not feel that you *must* work with the hardware yourself. You can always contact your service provider to have an authorized service provider work with the hardware instead.

Finding the Information You Need

The Indigo² workstation ships with the following sources of information, as shown in Figure 1-1.

- *Indigo² Workstation Owner's Guide* and pictorial setup poster
- *Software Installation Administrator's Guide*
- IRIX[™] *Release Notes* (on the CD)
- *IRIS InSight[™]* online documentation and help

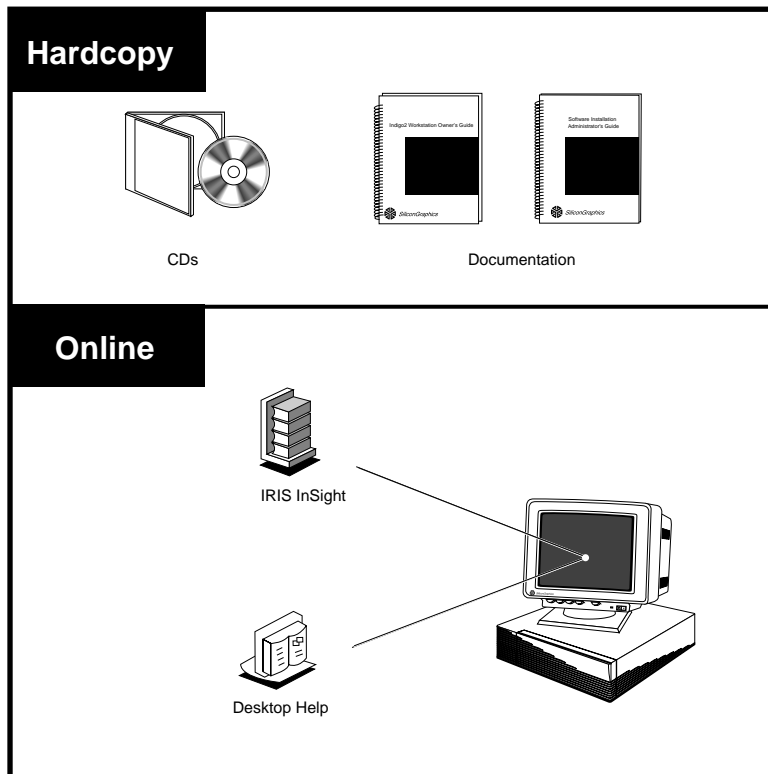

Figure 1-1 Sources of Information for the Indigo² Workstation

The following sections contain information on options that can help you get your workstation up and running and help you become productive as soon as possible.

Indigo² Workstation Owner's Guide

Refer to this manual (shown in Figure 1-2) to set up the system and install hardware options, or find solutions when you suspect there is a hardware problem. In addition, it contains basic information on installing and removing optional software.

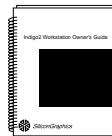

Figure 1-2 Workstation Owner's Guide

Software Installation Administrator's Guide

The *Software Installation Administrator's Guide* is the complete reference guide on using the installation program, *inst*, to install software. For information on using the Software Manager to install software, refer to the online *Personal System Administration Guide*.



Figure 1-3 Software Installation Guide

IRIS InSight Online Documentation and Help

The online documentation package is called IRIS InSight. The InSight icon is shown in Figure 1-4. To view the manuals, go to the Help toolchest and choose "Online Books." You see bookshelves for end-user, developer, and administration manuals that ship online with the system. Double-click on a book to open it.

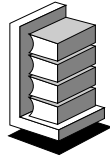

Figure 1-4 IRIS InSight Icon

For a description of the manuals and a listing of manuals that are available to purchase in hard copy, double-click on the *Documentation Catalog*.

Conventions

The documentation uses these conventions:

- References to other documents are in *italics*.
- References to other chapters and sections within this guide are in quotation marks.
- Names of buttons are in *italics*.
- Names of menu choices are in quotation marks.
- Numbered sentences are steps that you follow to complete a task. Below a step, sentences preceded by a box describe in detail how to do the step. For example:
 1. Remove the front cover.
 - Face the front of the Indigo² chassis.
 - Snap the cover away from the top edge of the chassis and tip it down.

Where to Go from Here

To set up the Indigo² workstation, go to Chapter 2, “Getting Started.” This chapter tells you how to choose a site, put all the pieces together, turn the system on, and set up your login account and network connection software.

To install extra SIMMs, go to Chapter 3, “Installing and Removing Memory.”

To install EISA boards, go to Chapter 4, “Installing and Removing EISA Boards.”

To install peripherals, go to Chapter 5, “Installing Peripherals.” This chapter tells you how to install internal and external drives, serial devices, and audio peripherals. You’ll also learn which modems, printers, and other cables you can use with your IRIS Indigo² workstation.

To install Silicon Graphics software, go to Chapter 6, “Installing Software.”

If you have a problem while powering on or using your Indigo² workstation, go to Chapter 7, “Troubleshooting.”

To order and replace parts, see Chapter 8, “Ordering, Removing, and Installing Replacement Parts.”

For information on maintenance and some tips on making your work environment comfortable, see Chapter 9, “Safety, Maintenance, and Regulatory Information.”

In addition to this manual, the Indigo² workstation ships with an online documentation package called IRIS InSight. To open IRIS InSight, choose “Online Books” from the Help toolchest.

Getting Started

This chapter explains how to connect the parts of your Indigo² workstation, turn the system on, log in, and set yourself up on a network. It also explains how to use the Indigo Magic User Environment.

Getting Started

This chapter tells you how to set up your Indigo² workstation. It includes instructions on:

- selecting a site
- checking your shipment
- putting all the pieces together
- turning on your system
- creating your login account
- setting up your network software
- shutting down and turning off your system
- locking your system

If you've already set up your Indigo² workstation and want to learn how to use the IRIX system software, go to "Using the Indigo Magic User Environment" on page 35.

If you want to mechanically secure your workstation, follow the instructions in "Locking Your Indigo² Workstation" on page 44.

Selecting a Site

Indigo² is designed to sit on or beside your desk. The monitor fits easily on top of the system. If you prefer to keep the system on the floor, you can attach the workstation stand that shipped with the system and set the system beside your desk.

Install any internal drives or memory first before placing your monitor on top of the system or placing the system beside your desk.

Select a site using these suggestions:

- Place Indigo² and the monitor within 6 feet of each other; you'll connect them with cables that are 10 feet long.
- Place Indigo² within 8 feet of a standard three-pronged (grounded) electrical outlet.
- Do not place Indigo² within a small, enclosed area, such as a closet, or it may overheat. It is important not to block the vents.
- Do not drape anything, such as a jacket or blanket, over Indigo².

Checking Your Shipment

The Indigo² workstation is shipped with the pieces shown in Figure 2-1. If you ordered extra memory or internal drives, they will be in separate boxes.

A fold-out poster ships in the box that contains the Indigo² chassis. This poster has pictorial instructions on how to unpack and set up the system. You can use the poster to set up your Indigo² or, if you prefer, you can follow the step-by-step instructions in this chapter.

After you unpack your Indigo² workstation and its parts, make sure you have all the parts shown in Figure 2-1.

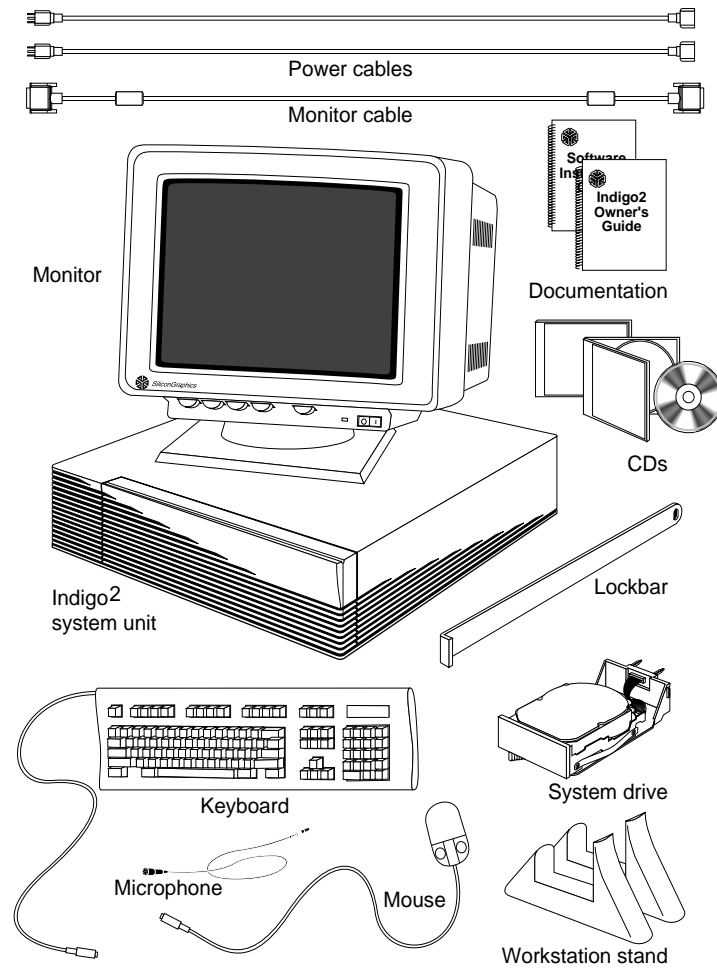

Figure 2-1 Indigo² Parts

About the CD Software Media

You received one or more compact discs (CDs) with your Indigo² workstation. The CDs include optional software that you might find useful, and a copy of the operating system and software installation tools that are already on your system disk. You don't need the compact discs to set up and use your system. Store them in a safe and convenient place so you can find them if you need to install new software, or if the system fails.

Note: Not all the software on these CDs is pre-installed on your system disk.

For more information on installing software, refer to Chapter 6, "Installing Software."

Putting the Pieces Together

Place the monitor next to the Indigo² chassis, near the site you selected, then follow the instructions in the next sections to:

- install the system disk in the lower right slot if the disk is not already installed in your system
- install any internal drives
- install optional memory (turn to Chapter 3, "Installing and Removing Memory," for instructions)
- set up the system
- attach the monitor, keyboard, mouse, and microphone to the system chassis
- attach the Ethernet cable if you will be attaching your system to a network
- attach the power cables to the system and monitor
- turn on your workstation and create your login account

Installing the System Disk, Any Internal Drives, and Additional Memory

If you are running your Indigo² as a diskless system or if you do not need to install the system disk, an internal drive, or memory, turn to "Setting Up the System" on page 20.

If you need to install memory, turn to Chapter 3, “Installing and Removing Memory,” for instructions.

If you need to install the system disk or other internal drives, follow the steps below.

1. Open the front cover.
 - Face the front of the Indigo² chassis.
 - Snap the cover away from the top edge of the chassis and tip it down, as shown in Figure 2-2.

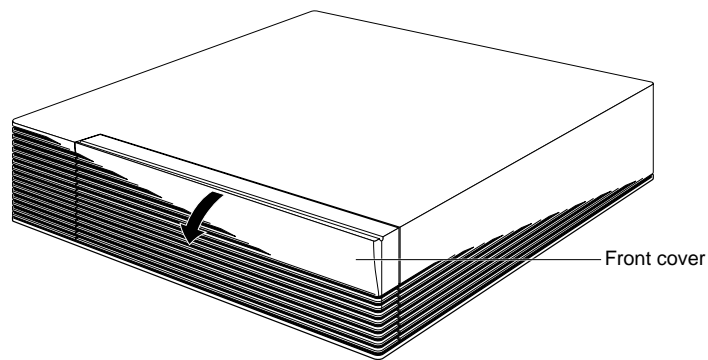

Figure 2-2 Opening the Front Cover of the Indigo² Chassis

2. Remove the front bezel.
 - Press down on the tabs on each side of the bezel, as shown in Figure 2-3.
 - Pull the bezel down and away from the chassis.

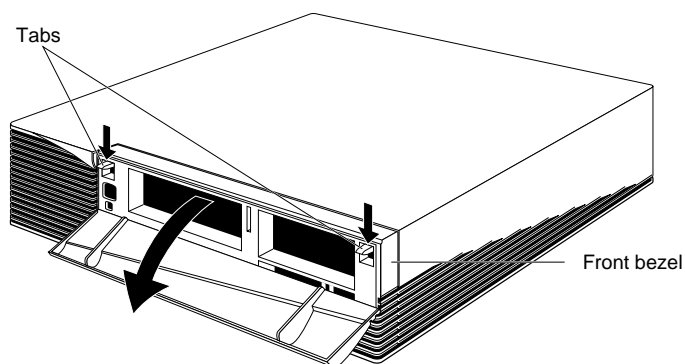

Figure 2-3 Removing the Front Bezel From the Indigo² Chassis

3. Install the system disk, as shown in Figure 2-4. If you are not installing a system disk, skip to step 4.

The system disk contains the operating system software that makes your workstation run. It's labeled:

```
SYSTEM DISK
Install in bottom slot
```

It has a black front panel with a green LED.

- Pick up the drive so the lever is facing you and is on the bottom of the drive.
- Slide the drive into the slot, making sure that the guides underneath the drive line up with the guides in the Indigo² chassis. As you slide the drive in, the lever moves to the right.
- Push the drive in firmly until you feel solid resistance.
- Push the lever all the way to the right. This locks the drive in place. The lever should be flush with the front of the drive.

Note: If the drive does not slide all the way into the slot, it may not be lined up with the guides in the Indigo² chassis. Take the drive out and reinstall it, making sure the guides on the bottom of the drive line up with the guides in the Indigo² chassis.

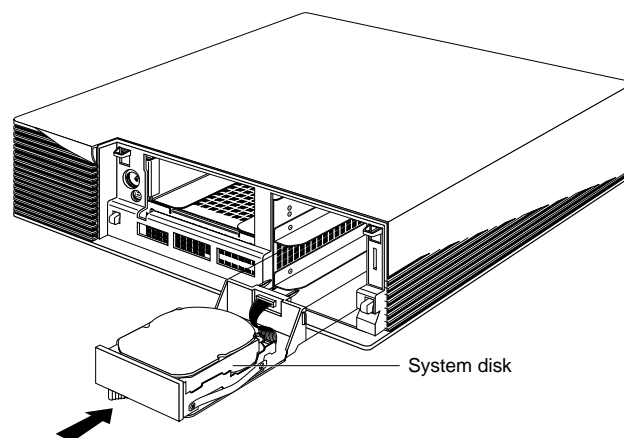

Figure 2-4 Installing the System Disk

4. Install any internal option drives.

An internal option drive is any drive other than the system disk. Option drives include floppy drives, secondary hard disk drives, QIC tape drives, CD-ROM drives, or DAT drives.

- Install option drives the same way you installed the system disk, as shown in Figure 2-5.
- You can install a floppy, secondary hard disk, or DAT drive in the 3-1/2" drive slot above the system drive slot. You can install a QIC tape drive, a hard disk drive, or a CD-ROM drive in the 5 1/4" drive slot to the left.
- Pick up the drive so the lever is facing you and is on the bottom of the drive.
- Slide the drive into the slot, making sure that the guides underneath the drive line up with the guides in the Indigo² chassis. As you slide the drive in, the lever moves to the right.
- Push the drive in firmly until you feel solid resistance.
- Push the lever all the way to the right. This locks the drive in place. The lever should be flush with the front of the drive.

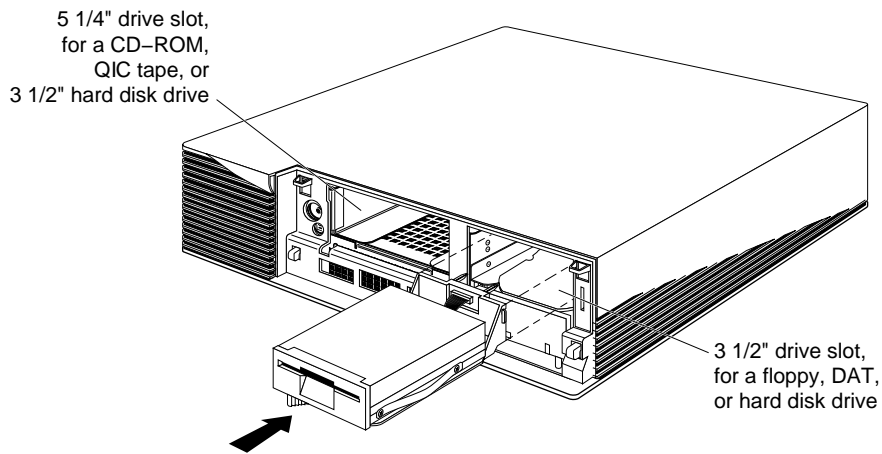

Figure 2-5 Installing an Option Drive

5. Replace the front bezel.
 - Place the tabs on the bottom of the cover in the grooves in the front of the chassis, as shown in Figure 2-6.
 - Tilt the bezel up until it snaps into place.

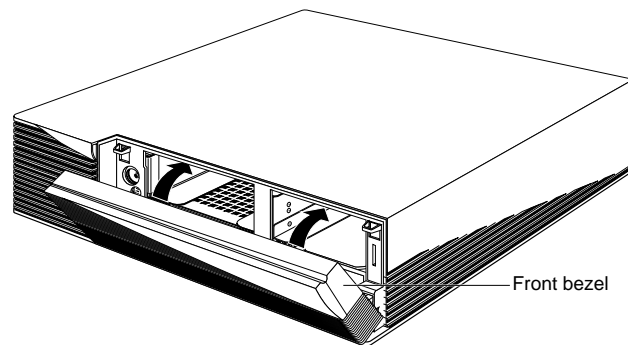

Figure 2-6 Replacing the Front Bezel on the Indigo² Chassis

You are finished installing the drives and are ready to set up the system.

Setting Up the System

You can place the monitor on top of your system, as shown in Figure 2-7, or you can place the system on the floor and set it in the workstation stand that came with your shipment.

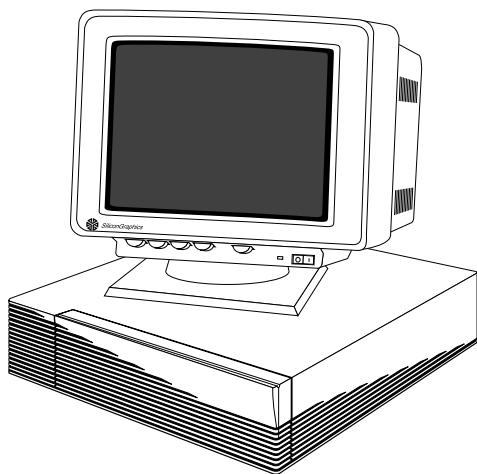

Figure 2-7 Placing the Monitor on Top of the Indigo² Workstation

To set the system in the workstation stand, follow these steps:

1. Face the front of the system.
2. Push the system so the left side is hanging off the edge of your work surface.

3. Look at the underside of the system. You will see guides for the workstation stand, as shown in Figure 2-8.
4. Press each piece of the workstation stand onto the system, aligning the pieces with the guides, as shown in Figure 2-8.
5. Tip the system down onto the floor so that it rests on the stand.

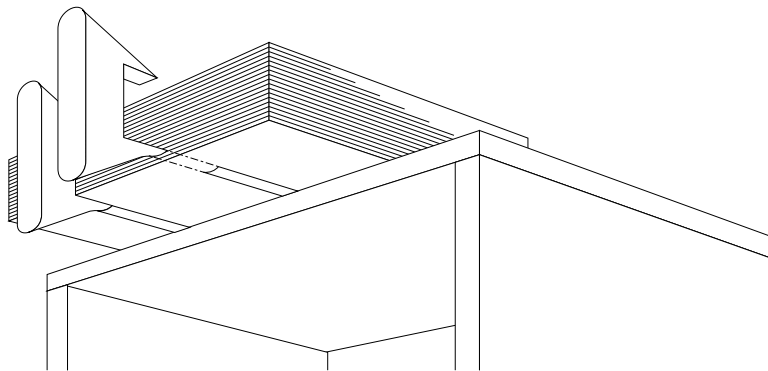

Figure 2-8 Attaching the Workstation Stand to the System

Connecting the Monitor, Keyboard, Mouse, and Microphone

To connect the monitor, keyboard, mouse, and microphone to the Indigo² chassis, follow these steps:

1. Connect the monitor cable to the monitor and the Indigo² chassis.
 - Connect one end of the cable to the connector on the back of the monitor, as shown in Figure 2-9. Screw in the thumbscrews on both sides of the connector.
 - Connect the other end of the cable to the connector with the monitor icon on the back of the Indigo² chassis, as shown in Figure 2-9. Screw in the thumbscrews on both sides of the connector.

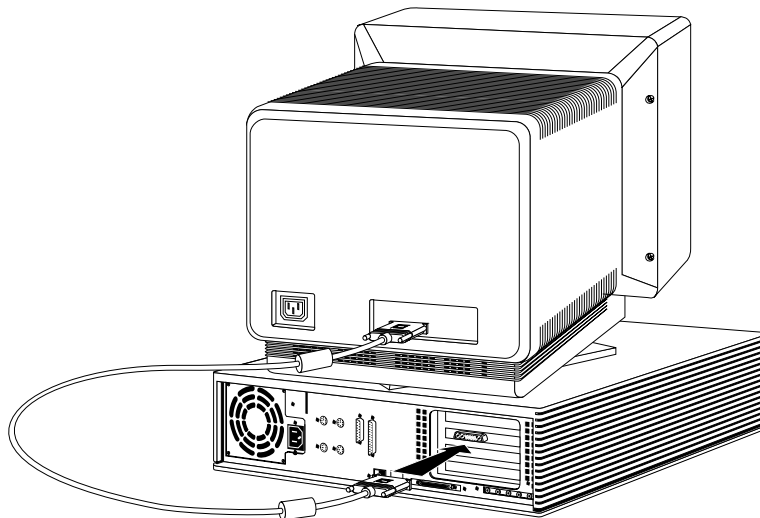

Figure 2-9 Connecting the Monitor Cable to the Indigo² Chassis

2. Connect the keyboard cable to the connector below the keyboard icon on the back of the Indigo² chassis, as shown in Figure 2-10.

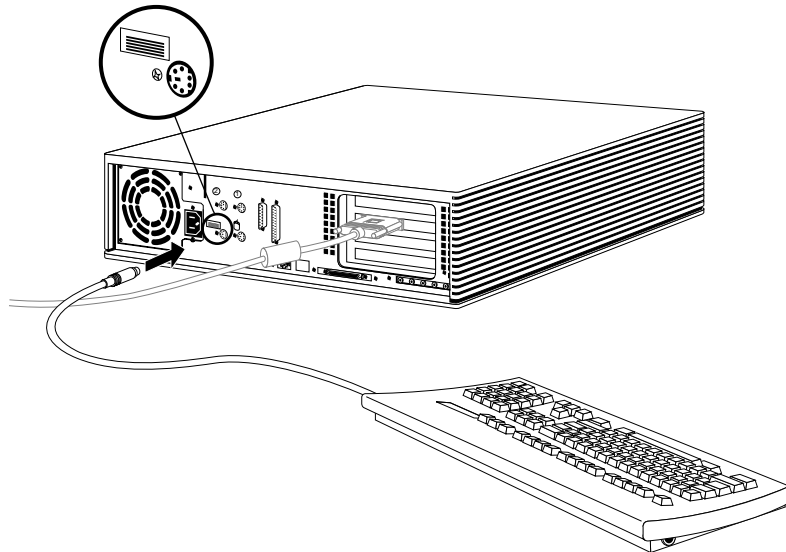

Figure 2-10 Connecting the Keyboard Cable to the Indigo² Chassis

3. Connect the mouse cable to the connector below the mouse icon on the back of the Indigo² chassis, as shown in Figure 2-11.

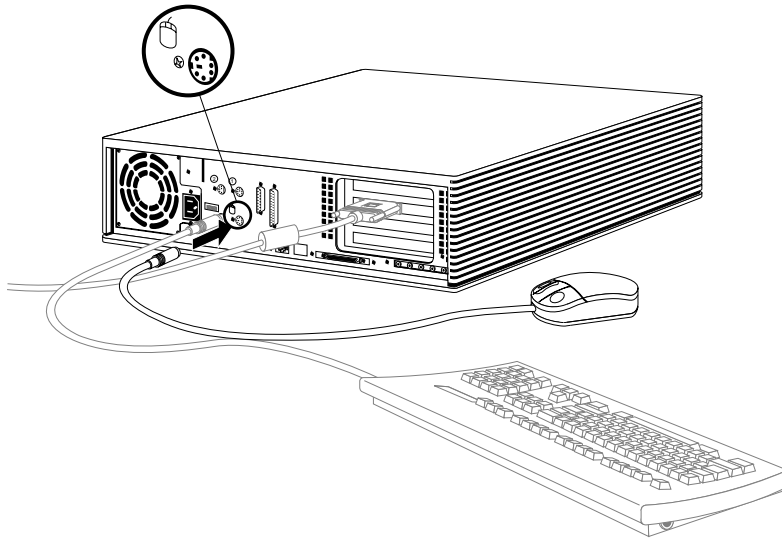

Figure 2-11 Connecting the Mouse Cable to the Indigo² Chassis

Note: The Indigo² workstation uses mice and keyboards that are PS/2 compatible. They are not interchangeable with older Silicon Graphics mice and keyboards. For a listing of some off-the-shelf PC keyboards that work with Indigo², type `man pckeyboard` from a shell window.

The default keyboard language is U.S. English. Since the Indigo² system uses a PS/2 compatible keyboard that does not automatically identify the varied international keyboard languages that Silicon Graphics offers, you must set the nationality manually if you want to change the keyboard language. To find out how to do this, see Appendix B, “International Keyboard Support.”

4. Connect the microphone to the connector above the microphone icon on the back of the Indigo² chassis, as shown in Figure 2-12.

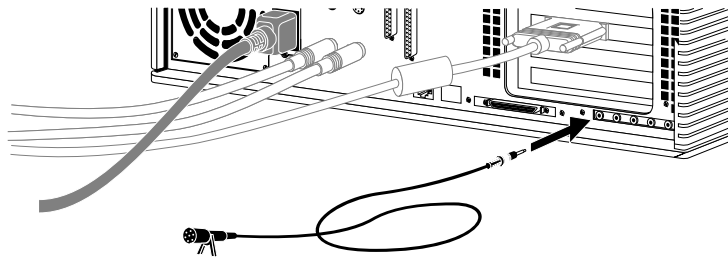

Figure 2-12 Connecting the Microphone to the Indigo² Chassis

Attaching the Ethernet Cable

The Indigo² workstation supports two types of Ethernet connections on the main system (only one of which may be connected):

- Ethernet AUI (electrically Ethernet type 2)
- Ethernet 10-BASE T

For information on which type of Ethernet to use, see your network administrator.

To attach an Ethernet AUI cable, see below. To attach an Ethernet 10-BASE T cable, turn to “Attaching an Ethernet 10-BASE T Cable” on page 27.

Note: If you attach both an Ethernet AUI cable and an Ethernet 10-BASE T cable to your system, and if the Ethernet 10-BASE T connection is “live,” the system will use Ethernet 10-BASE T.

Attaching an Ethernet AUI Cable

To attach an Ethernet AUI cable to your system, follow these steps:

1. From your network administrator, obtain a drop cable that is long enough to reach the back of your Indigo², but no longer than 75 feet, for correct operation.
2. Attach the Ethernet cable to the Ethernet port on the back of the Indigo² chassis, as shown in Figure 2-13.

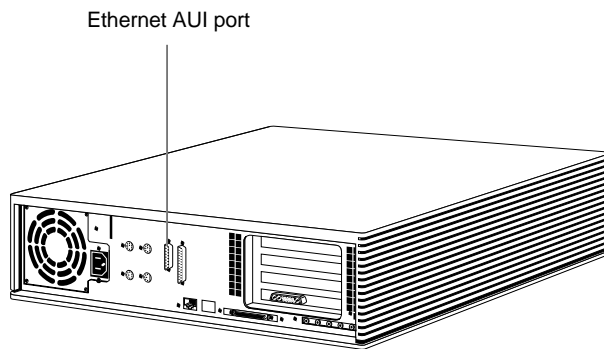

Figure 2-13 Ethernet AUI Port on the Back of the Indigo² Chassis

- Make sure the sliding bracket on the Ethernet port on the system is pushed all the way down, as shown in Figure 2-14.
- Plug the cable into the port.
- Slide the bracket up to hold it in place.

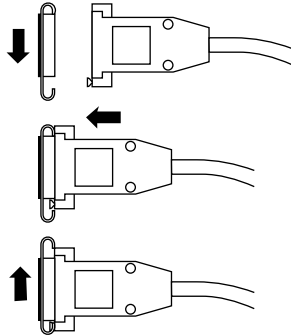

Figure 2-14 Connecting the Standard Ethernet Cable

You are finished installing the Ethernet AUI cable. Turn to “Attaching the Power Cables” on page 28 to attach the power cables.

Attaching an Ethernet 10-BASE T Cable

If you are attaching an Ethernet 10-BASE T cable to your system, follow these steps:

- 1. From your network administrator, obtain a 10-BASE T cable that reaches from the wall to the back of your Indigo².
- 2. Plug one end of the cable into the Ethernet 10-BASE T port on the back of the Indigo² chassis, as shown in Figure 2-15.

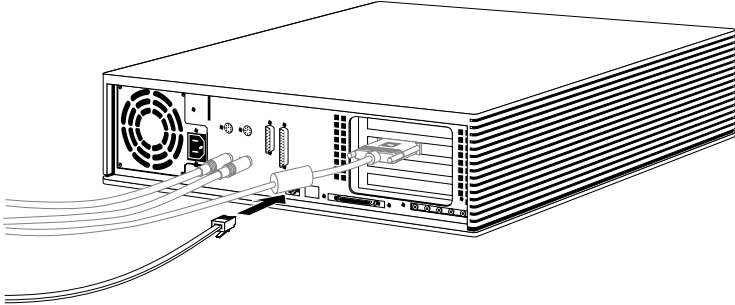

Figure 2-15 Attaching an Ethernet 10-BASE T Cable to the Indigo² Chassis

Note: There are earlier versions of cabling similar to 10-BASE T. These may mechanically fit the Indigo² connector, but do not work electrically.

Attaching the Power Cables

You received two identical power cables—one for the monitor and one for the Indigo² workstation. Silicon Graphics monitors and Indigo² base systems accept 90-240 V and 50 or 60 Hz.

To attach the power cables, follow these steps:

1. Connect one power cable to the monitor, as shown in Figure 2-16.
 - Connect the socket end of the power cable to the power connector on the back of the monitor.
 - Plug the other end into a three-pronged grounded electrical outlet.

Note: For voltage and frequency requirements, see the manual that came with your monitor.

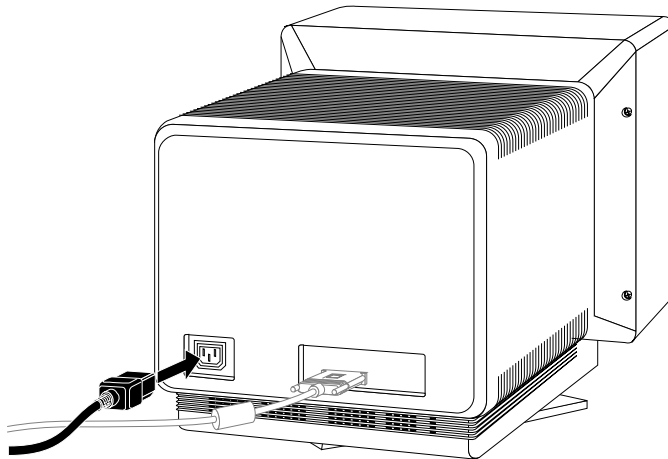

Figure 2-16 Attaching the Power Cable to the Monitor

2. Connect the other power cable to the system, as shown in Figure 2-17.
 - Connect the socket end of the power cable to the power connector on the back of the Indigo² chassis.
 - Plug the other end into a three-pronged grounded electrical outlet.

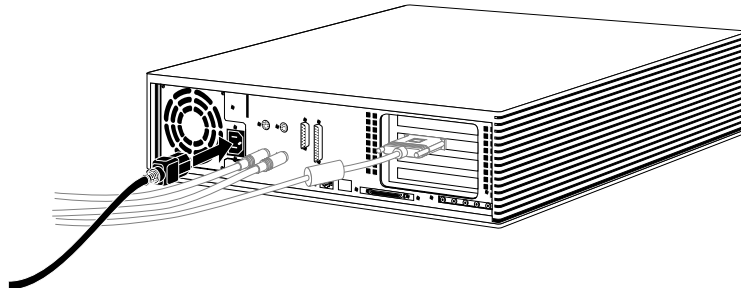

Figure 2-17 Attaching the Power Cable to the Indigo² Chassis

You are finished setting up your Indigo² and are ready to power up the system.

Turning On the Indigo² Workstation

Once you've connected all of the pieces, as described in the last section, power up and log in to your workstation by following these steps:

1. Turn on the monitor.

The monitor's power switch is on the front of the monitor in the lower right corner. The LED next to the switch lights up when you turn on the monitor.

2. Turn on the system power.

- Open the front cover by snapping it away from the top edge of the chassis and tipping it down.
- Press the power switch to turn on the system, as shown in Figure 2-18.

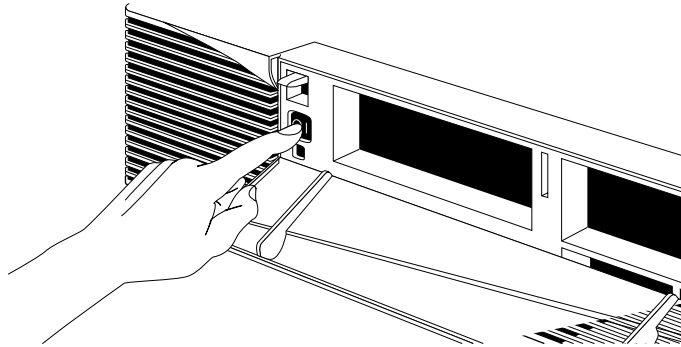

Figure 2-18 Turning on the Indigo² Workstation

When you power on your system, you hear the boot “tune” and see the LED on the front of the machine turn on. While the system is running power-on diagnostics, you see an orange light. Then you see the notifier shown in Figure 2-19. If you don't see the notifier, go to Chapter 7, “Troubleshooting.”



Figure 2-19 Running the Power-On Diagnostics Notifier

If the system passes all of the diagnostics tests, the light turns green, the system continues booting, and you see the startup notifier shown in Figure 2-20.



Figure 2-20 System Startup Notifier

After a few seconds, you see the notifier shown in Figure 2-21.



Figure 2-21 System is Coming Up Notifier

If you do not hear the boot tune or the LED does not turn green, there may be a problem. Go to Chapter 7, "Troubleshooting" to run some tests.

The system now boots the operating system and then you see the login screen.

Logging In to the Workstation

Welcome to your new system. Once you create a user login account for yourself and set up networking software, your system has the basic information it needs to create a personal work area for you and to let you communicate with other systems and people on your network.

If this is the first time the system is being booted, you see a login screen similar to the one shown in Figure 2-22.



Figure 2-22 The Login Screen

If you already have a login account, you'll see an icon with your login name. Double-click the icon. If you do not have a login account, double-click the *EZsetup* icon and go to the next section, "Creating Your Login Account and Network Connection."

Creating Your Login Account and Network Connection

After double-clicking the *EZsetup* icon, you see the EZsetup screen shown in Figure 2-23.

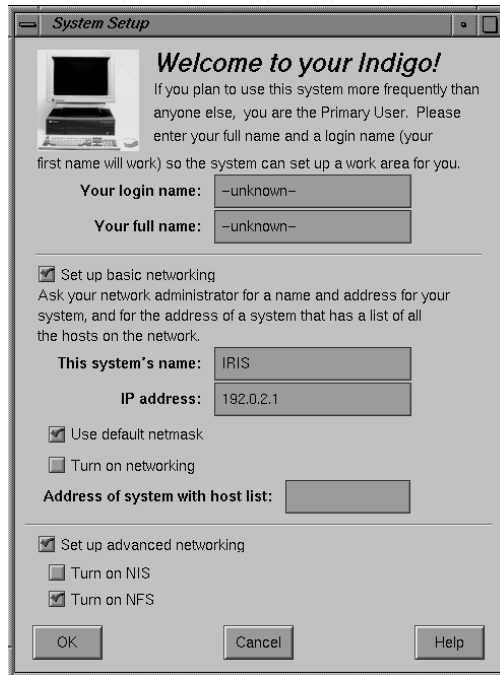

Figure 2-23 The EZsetup Screen

Setting up your login account through EZsetup gives you administrative (root) privileges.

- If you plan to connect to an existing network, contact your network administrator for a login name for yourself, a hostname and IP address for your system, and the IP address of another system on the network that has a master list of all systems on the network. Then go to Step 1 below.
- If you don't have the network information, you can complete the *login name* and *full name* fields, and click the *OK* button to set up your login account. Your network administrator can set up your network connection later. Or you can set it up yourself by choosing "System Manager" from the System toolchest and double-clicking the *Network Setup* icon.

For more information on setting yourself up on a network, log in and select "Online Books" from the Help toolchest. Then select the *Personal System Administration Guide* and look in Chapter 3, "Setting up Network, Peripheral, and Printer Connections."

Follow the steps below to set up your login account and network connection.

Note: If you change your mind at any time while entering the information, click the *Cancel* button. The system makes no changes, logs you out of the EZsetup account, and shows the login screen again.

1. Type your login name (usually a shorter version of your name; for example, your first name or initials) in the field labeled *Your login name*.
2. Type your full name in the field labeled *Your full name*.
3. If your system is already physically connected to a network, and you have the necessary network information from your network administrator, go on to step 4. If your system is not connected to a network, skip to step 5.
4. Move the cursor over the box next to *Set up basic networking*, and click the mouse button. Enter the network information that your network administrator provided.
 - Type the hostname in the field labeled *This system's name*.
 - Type the IP address in the IP address field. Make sure it consists of two to four numbers, separated by periods, such as 192.0.2.2
 - The box next to *Use default netmask* is checked by default. Do not remove the check mark unless your network administrator wants to specify a custom netmask.
 - Click the box next to *Turn on networking*. The system will not turn on the networking software until you click *OK*.
 - In the field labeled *Address of system with host list*, type the IP address of a system on the network that contains a master list of all other systems on the network, if there is one. If not, use a system that has your system listed.

5. When all the information is correct, click the OK button.

The system sets up the software, logs you out of the EZsetup account, and shows the login screen displaying people who have accounts on the system.

6. When you see the login screen, log in to your new account by double-clicking the icon that's labeled with your login name.

Now that you have a login account, go to the next section to learn about the desktop management system called the Indigo Magic User Environment.

Using the Indigo Magic User Environment

Once you're logged in, you are in the Indigo Magic User Environment. Before learning about the environment, however, you may be interested in learning a few tips and shortcuts for using the mouse.

Mouse Techniques and Shortcuts

To get started, you need to know a few basic techniques for using the mouse and working with icons.

- To *select an icon*, place the cursor over the icon and then press the left mouse button. Icons turn yellow when they are selected.
- To *select several icons*, press the <shift> key while selecting the icons, or press the left mouse button in the background and drag the mouse. A box is created as you drag the mouse. All icons touched by the box you create are selected.
- To *open an icon*, place the cursor over the icon and then double-click the left mouse button. When you open an application icon, you run the application; when you open a folder icon, you open a window that shows the contents of that directory.
- To *drag and drop icons*, place the cursor on an icon, press the left mouse button, and move the mouse. Release the mouse button to drop the icon.

This drag-and-drop technique lets you copy icons from one directory to another and launch applications with a particular file.

- To *display a pop-up menu that contains commands from the Selected menu*, place the cursor over a window and then press the right mouse button. (Not all windows have pop-up menus.)

Now you are ready to use the desktop management system called the Indigo Magic User Environment.

Reading the following sections will give you a quick overview of the new environment and help you become productive rapidly.

The Desktop and the Icons

When you log in, a collection of windows and icons (small pictures) appears on your screen by default. If you don't see any items on your screen, contact your system administrator to see if the *desktop* has been disabled.

The screen background is called the desktop. It's a place for you to set frequently used icons so you have quick and easy access to them. In this way, the desktop is similar to an actual office desk. For example, on your desk you might have a telephone, a container of pens and pencils, and a stack of folders or notebooks related to the projects on which you're currently working. Other, less frequently used items are stashed away in desk drawers. Your online *desktop* mimics this arrangement using icons.

The default *desktop* contains:

- the console window
- the toolchest
- the *desktop* and the icons that appear on it

By default, several icons (small pictures) appear on the *desktop*: a folder icon representing your home directory, a dumpster icon, and icons for peripherals you have installed. (See Figure 2-24.)



Figure 2-24 Desktop Icons

The peripheral icons show the current state of the devices they represent. For example, if you place a music CD into the compact disc player, the icon changes to display a few musical notes. (See Figure 2-25.) When you double-click the icon, it opens CD Manager, a utility that lets you play and record from a compact disc.



Figure 2-25 CD Player Icon

Console Window

The small box next to the stack of toolchests is the console window. It looks like a small box because it has been minimized. You can open it to its full size by clicking on it with the left mouse button. Many of the error messages that the system generates appear in this window.



Figure 2-26 The Minimized Console Window

Clicking on the console brings up the IRIX™ shell where you can type IRIX commands. For information on IRIX commands, from the Help toolchest, choose “Online Books.” Select *IRIS Essentials* and look for “Using IRIX Commands.”

The Toolchest

The toolchest in the top left hand corner of the screen (shown in Figure 2-27) provides a listing of most of the system functions and programs. Under the System toolchest is the

System Manager, which provides hardware information about your workstation. From the Help toolchest you can access the library of online documentation and online help.



Figure 2-27 The Toolchest

To pop up a menu, move the cursor over a label on a toolchest, then press the left or right mouse button.

IRIS InSight and Online Help

The Indigo² workstation includes IRIS InSight, a library of online documentation and extensive online help that is available from the desktop and from most Silicon Graphics applications. From the desktop, you access the online help and documentation from the Help toolchest as follows:

- From the Help toolchest, choose “Online Books” and the IRIS InSight Document Library appears. Once the IRIS InSight Document Library is open, you can open a manual and read it, or you can type in a word or phrase and quickly find the information you need. See the IRIS InSight online help for instructions.
- From the Help toolchest, choose “Desktop Help.” A listing of system-level help appears. Additionally, each application provides a Help button or Help menu so that you can get help on a particular application.

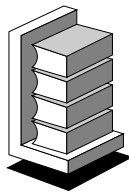

Figure 2-28 IRIS InSight Icon

Shutting Down and Powering Off Your Indigo² Workstation

There are two ways to shut down and power off your Indigo² system:

- use the power switch to shut down the system software and power off
- use the Toolchest menu to shut down the system software and return to the System Maintenance menu or power off

Using the Power Switch to Shut Down the System

To use the power switch to shut down the software and power off the system, follow these steps:

1. Open the front cover of the chassis, as shown in Figure 2-29.
 - Face the front of the Indigo² chassis.
 - Snap the cover away from the top edge of the chassis and tip it down, as shown in Figure 2-29.

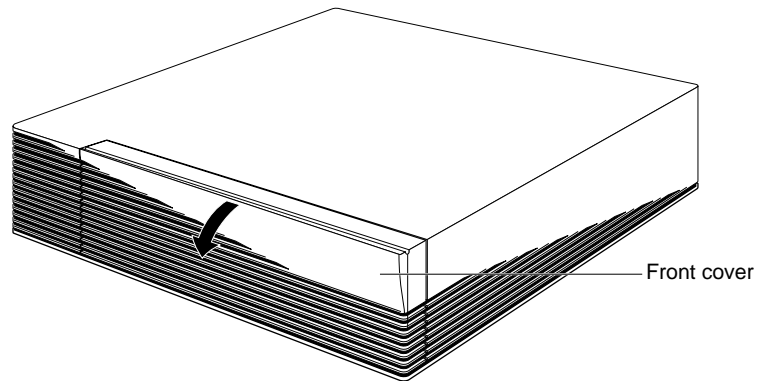

Figure 2-29 Opening the Front Cover

2. Press and release the power switch, as shown in Figure 2-30.

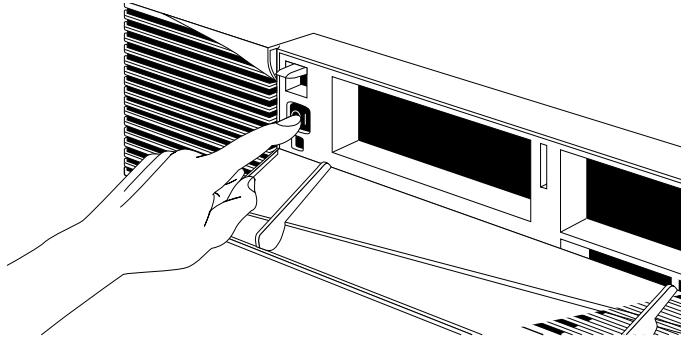

Figure 2-30 Pressing and Releasing the Power Switch

3. The notifier shown in Figure 2-31 appears on your screen within a few seconds. Then the system powers off automatically within the next minute.

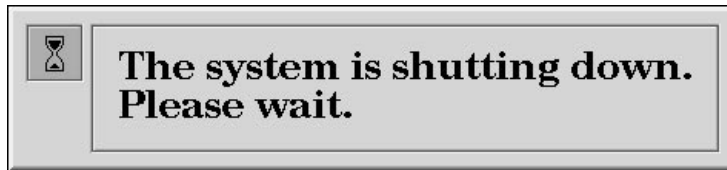

Figure 2-31 System Power Off Notifier

4. Turn off the monitor by pressing the monitor power switch.

If the system does not power off, either the system never came up all the way, or the operating system is hung. If you do not see any activity for several minutes, follow the steps below.

1. Press and hold the power button again.

Note: If you press the power button a second time, the system powers off immediately, but it is not a clean shutdown. Avoid using this method unless the system does not respond for several minutes after you press the power button the first time.

2. If that doesn't work, press the reset button, wait a few seconds, and then press the power button.
3. If the system still fails to power off, unplug the power cord from the back of the system and contact your maintenance provider.

Using the Toolchest to Shut Down the System

You can use the System menu in the Toolchest to shut down the system. You can also choose to power off the system. To do this, follow these steps:

1. Choose "System Shutdown" from the System menu in the Toolchest.
 - Place the cursor over the word "System" in the Toolchests and click the left or right mouse button. The toolchests are shown in Figure 2-32.
 - Place the cursor over the words "System Shutdown" and click the mouse button.



Figure 2-32 The Toolchest

After a few seconds you see the notifier shown in Figure 2-33.

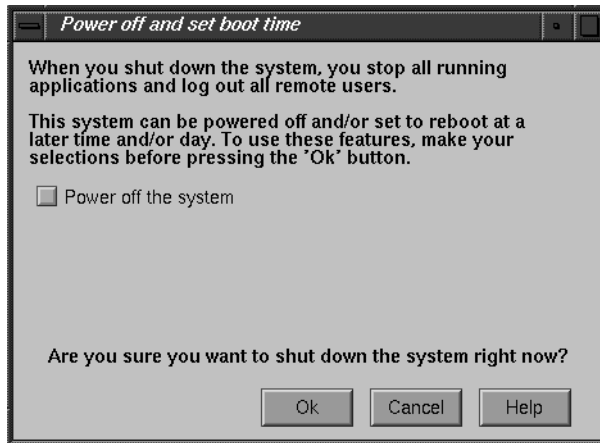

Figure 2-33 System Shutdown Caution Message

At this point you can either power off the system, or shut down the system and get the System Maintenance Menu.

2. To power off the system, click *Power Off the System* and then click *OK*.
The screen clears and you see the notifier shown in Figure 2-34. After a few seconds, the system powers off.
3. To shut down the system and get the System Maintenance Menu, do the following:
 - At the notifier shown in Figure 2-33, click *OK*. The screen clears and you see the notifier shown in Figure 2-34.

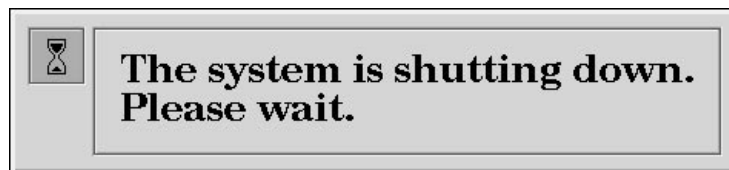

Figure 2-34 System Shutdown Notifier

Next you see the message shown in Figure 2-35.

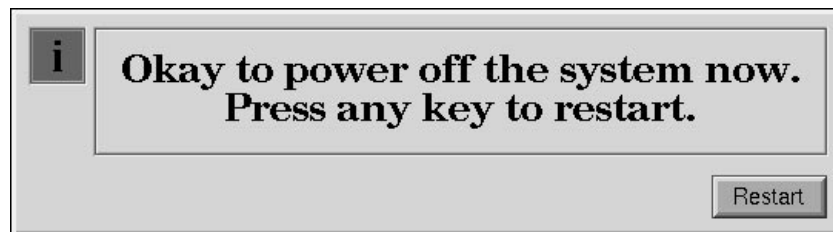

Figure 2-35 Okay to Power Off Notifier

- Click *Restart*. You see the system startup message shown in Figure 2-36.

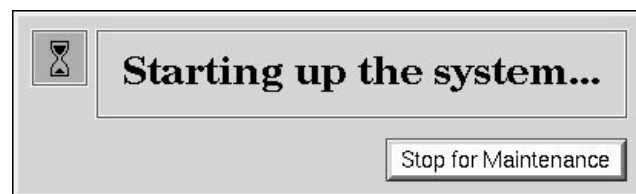

Figure 2-36 Starting Up the System Notifier

- Click *Stop for Maintenance* or press <Esc> to bring up the System Maintenance menu.

Locking Your Indigo² Workstation

To lock your Indigo², follow these steps:

1. Snap the front cover away from the top edge of the chassis and tip it down.
2. Place the straight end of the lockbar into the opening in between the disk drive slots in the front of the chassis, and push the lockbar all the way through the system, as shown in Figure 2-37.

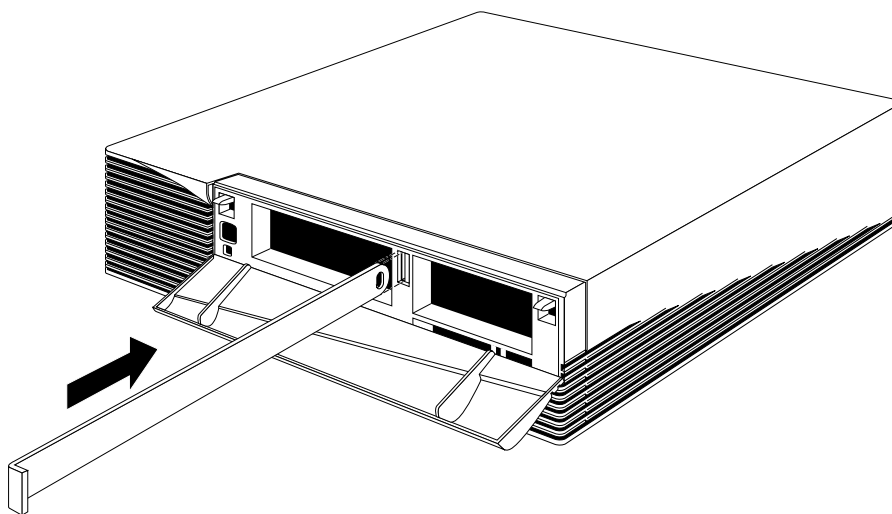

Figure 2-37 Installing the Lockbar

3. Attach a lock through the hole in the lockbar in the back of the system to lock the system, as shown in Figure 2-38.

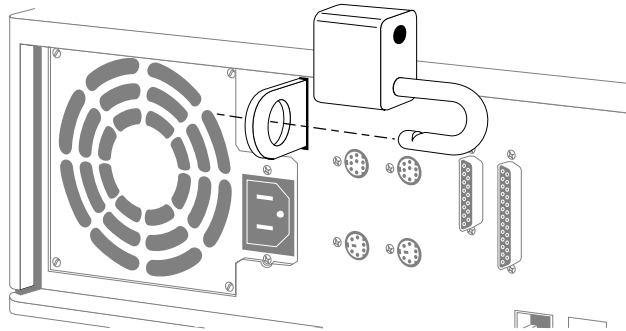

Figure 2-38 Locking the Indigo² Workstation

4. Close the front cover.

Congratulations! You have finished setting up your Indigo² workstation.

Installing and Removing Memory

This chapter describes how to install and remove SIMMs (Single Inline Memory Modules) in your Indigo² workstation.

Installing and Removing Memory

This chapter tells you how to install and remove single in-line memory modules (SIMMs). You may need to remove and replace SIMMs if you are upgrading the memory in your system. Also, if diagnostic tests report failures, or if you get memory parity errors (see Chapter 7, “Troubleshooting”), you may need to remove and replace SIMMs.

Installing Memory

Many customers order additional memory for their systems. You may have received extra SIMMs with your Indigo² shipment or later in a separate package.

Carefully follow all steps in the following sections to shut down your system, remove the cover, install the SIMMs, replace the cover, and test to make sure the SIMMs are installed and working properly.

Shutting Down and Powering Off the System

To shut down and power off the system, follow these steps:

1. Open the front cover.
2. Press and release the power switch on the front of the system to shut down the software and power off the system.

The system powers off automatically.

3. Press the monitor power switch to turn off your monitor.
4. Disconnect the power cable from back of the Indigo².

Removing the Cover

Once the system is shut down and the power cable is disconnected, follow these steps:

1. Remove the front bezel.
 - Press down on the tabs on each side of the bezel, as shown in Figure 3-1.
 - Pull the bezel down and away from the chassis.

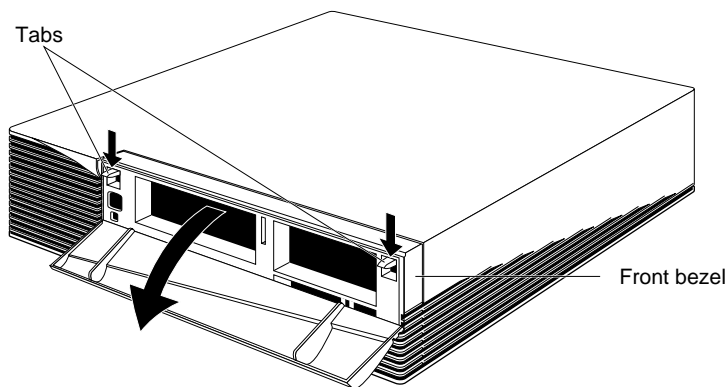

Figure 3-1 Removing the Front Bezel From the Indigo² Chassis

- Remove the top cover, as shown in Figure 3-2.
- Press up on the tabs on each side of the drive openings.
- Pull up on the cover and rotate it back and away from the chassis.

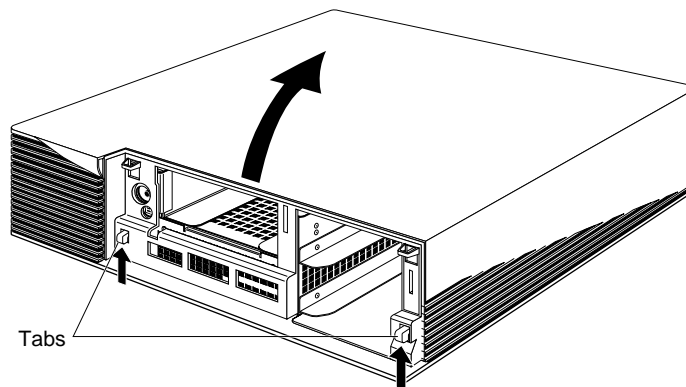

Figure 3-2 Removing the Top Cover From the Indigo² Chassis

Installing the SIMMs

To install SIMMs, follow these steps:

1. Ground yourself to a metal part of the chassis.
 - Put the wrist strap over your wrist, making sure it's tight against your arm.
 - Attach its alligator clip to a metal part of the chassis.

Caution: The system's internal components are sensitive to static electricity. Handle the parts carefully, and wear the wrist strap to avoid the flow of static electricity.

2. Face the back of the chassis and locate the SIMM sockets.

The sockets are located in the center of the system, toward the back, as shown in Figure 3-3. There are twelve sockets, split into three banks—A, B, and C. Bank C are the four sockets farthest away from you. Bank B are the next four sockets. Bank A are the four sockets closest to you.

Install SIMMs consecutively, in groups of four, beginning with the open slot farthest away from you (from C to A).

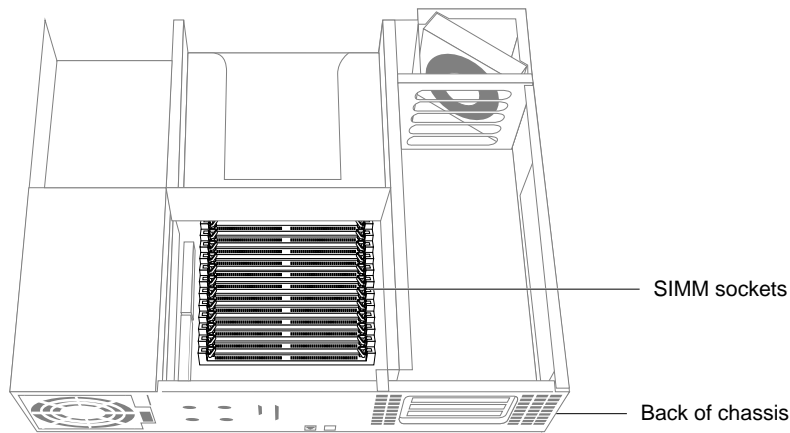

Figure 3-3 Locating the SIMM Sockets

3. Disconnect the SCSI cable from the back of the 5-1/4" drive tray. This allows better access to the SIMM slots.
4. Install the first SIMM.

Note: If you are installing SIMMs in bank C, you will must remove the 5-1/4" drive tray first, before installing the SIMMs. Turn to "Removing the 5-1/4" Drive Tray" on page 60 for instructions.

- Facing the rear of the system and using both hands, grasp the top of the SIMM so the notch in the bottom corner of the SIMM is on your left, as shown in Figure 3-4.

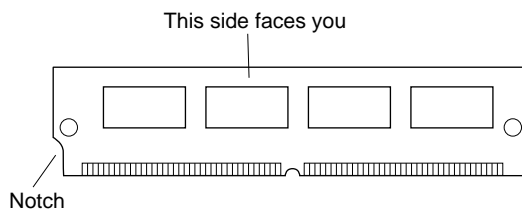

Figure 3-4 Orienting the SIMM When Facing the Rear of the Chassis

- Tip the top of the SIMM toward you, as shown in Figure 3-5, and press the SIMM securely into the socket at a 45-degree angle to the board.
- Tilt the SIMM up into a vertical position.
- The SIMM is positioned correctly when the latches on both sides of the SIMM socket are hugging the edges of the SIMM.

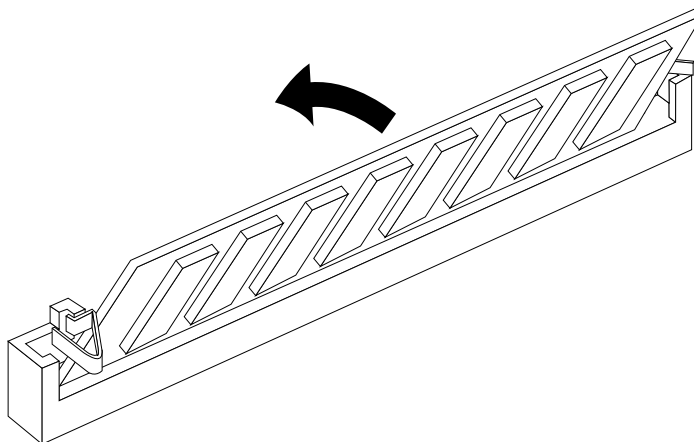

Figure 3-5 Tilting the SIMM up to a Vertical Position

5. Install the other SIMMs.
6. Visually check the tops of the SIMMs to make sure they are installed all the way.

If a SIMM is not sitting vertically, push it farther upward.

7. Reconnect the SCSI cable on the back of the 5-1/4" drive tray.

You are ready to replace the cover.

Replacing the Cover

It is important to replace the cover before testing the SIMMs. This ensures proper airflow through the system while the system is running the test.

To replace the cover, follow these steps:

1. Replace the top cover.
 - Facing the front of the system, place the prongs on the underside of the cover into the slots under the top ridge of the backplane of the chassis, as shown in Figure 3-6.
 - Lower the cover down onto the chassis until it snaps into place.

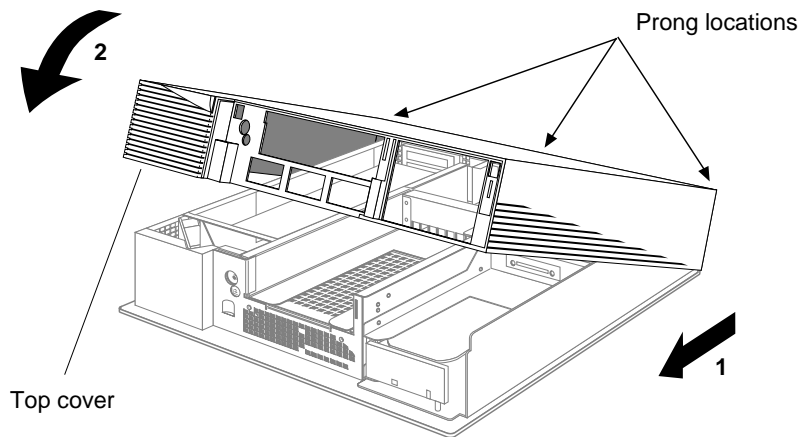

Figure 3-6 Replacing the Top Cover on the Indigo² Chassis

2. Replace the front bezel.
 - Place the tabs on the bottom of the bezel in the grooves in the front of the chassis, as shown in Figure 3-7.
 - Tilt the bezel up until it snaps into place.

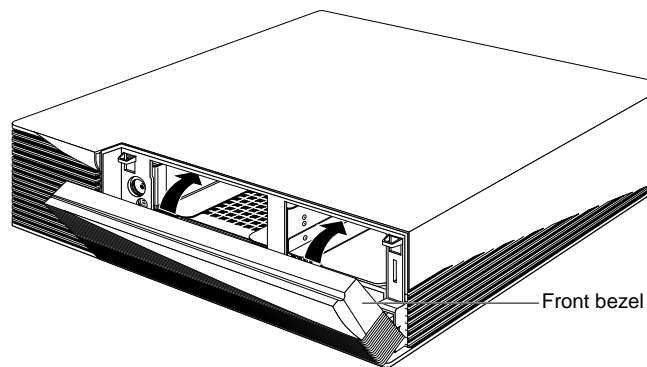

Figure 3-7 Replacing the Front Bezel on the Indigo² Chassis

3. Reconnect the power cable to the connector on the back of the system.

You are now ready to power up the system and check the new memory.

Checking New Memory

Now make sure the system recognizes the new memory. To check the amount of memory on your system, follow these steps:

1. If your Indigo² is new, make sure you've already installed the system disk before turning on the system.
2. Press the power switch to turn on the power.

After the power-on diagnostics run, you'll see a notifier, as shown in Figure 3-8.

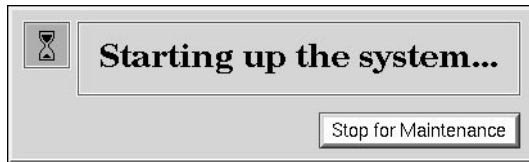

Figure 3-8 System Startup Notifier

After a few seconds, you see the notifier shown in Figure 3-9.



Figure 3-9 System is Coming up Notifier

The system boots up and brings up the login screen.

If no picture appears on your screen and the yellow fault light blinks, one or more SIMMs are not installed correctly. Turn off the system, remove the cover, and check that the SIMMs are installed correctly. Then try this procedure again. If it still fails, see Chapter 7, "Troubleshooting."

3. Log in to your account. For more information on logging in, refer to "Logging In to the Workstation" on page 31.

When you log in, the default desk appears. In the upper left-hand corner of the screen are the toolchests.

4. Choose "System Manager" from the System toolchest.

You see a window showing Hardware and Shared Resources.

5. Look under the Hardware listing for the line showing memory. The amount of memory shown in megabytes should equal the amount of memory that came with the Indigo² plus the amount of memory you installed.

For example, if you had 32 MB of memory on the Indigo² when you started and you installed another 32 MB, you should have a total of 64 MB.

Note: If the amount of memory you just installed is not added to the original amount, the SIMMs are not installed correctly. Make sure that all of the SIMMs are all the way in. Return to “Installing Memory” on page 49 to check the SIMMs. Then try this procedure again.

Now you are ready to use the Indigo2 workstation.

Removing Memory

You may need to remove SIMMs if one fails or if you want to upgrade the memory in your system.

Caution: SIMMs and the system’s internal components are sensitive to static electricity. Handle the SIMMs carefully, and wear the wrist strap to avoid the flow of static electricity.

To remove memory SIMMs, you must shut down the system, remove the cover, remove the 5-1/4" drive tray (if necessary), and remove the SIMMs. Then, replace the 5-1/4" drive tray (if you removed it) and the cover. You’ll need a phillips screwdriver to remove the 5-1/4" drive tray.

Shutting Down the System

To shut down the system, follow these steps:

1. Open the front cover.
2. Press and release the power switch on the front of the system to shut down the software and power off the system.

The system powers off automatically.

3. Disconnect the power cable from back of the Indigo².

Removing the Cover

Once the system is shut down and the power cable is disconnected, follow these steps:

1. Remove the front bezel.
 - Press down on the tabs on each side of the bezel, as shown in Figure 3-10.
 - Pull the bezel down and away from the chassis.

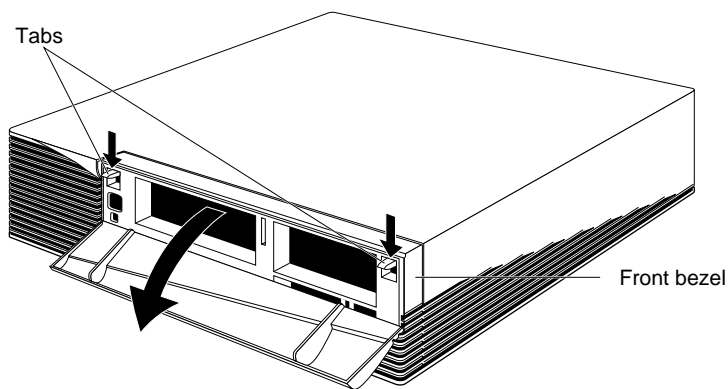

Figure 3-10 Removing the Front Bezel from the Indigo² Chassis

2. Remove the top cover.
 - Press up on the tabs on each side of the drive openings.
 - Pull up on the cover and rotate it back and away from the chassis, as shown in Figure 3-11.

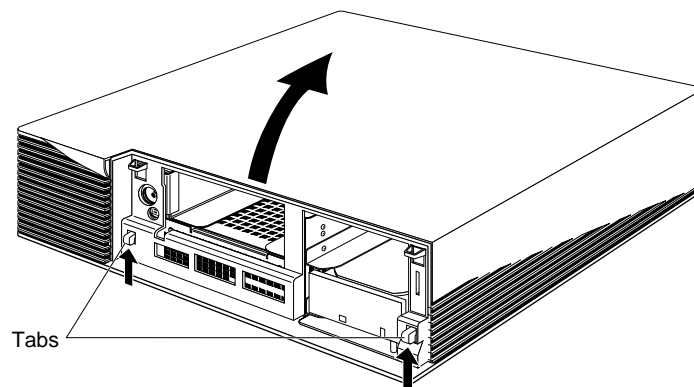

Figure 3-11 Removing the Top Cover From the Indigo² Chassis

Locating the Memory SIMMs

The SIMMs are located in the center of the system, toward the back, as shown in Figure 3-12.

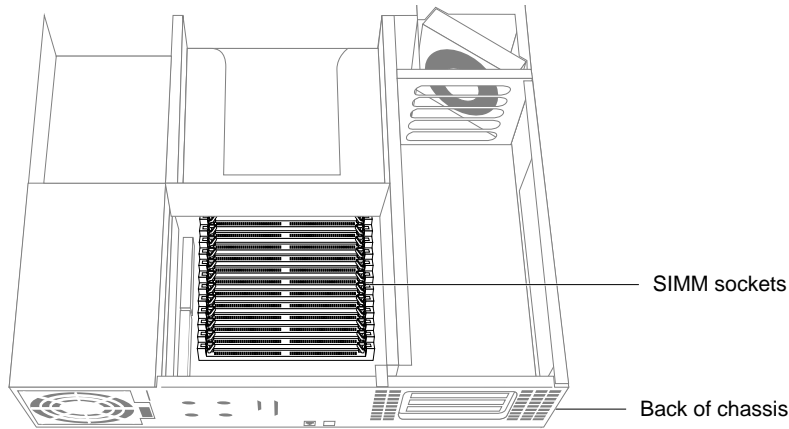

Figure 3-12 Locating the Memory SIMMs

Removing the 5-1/4" Drive Tray

The first few SIMMs are located beneath the 5-1/4" drive tray. If you need to remove these SIMMs, you must first remove the drive tray. See “Removing the 5-1/4" Drive Tray” on page 60 for instructions.

If the SIMMs you are removing are not covered by the 5-1/4" drive tray, *you do not need to remove the tray*. Turn to “Removing the Memory SIMMs” on page 63 for instructions on how to remove the SIMMs.

To remove the 5-1/4" drive tray, follow these steps:

1. Ground yourself to the system.
 - Attach the alligator clip of the wrist strap to a metal part of the chassis. Make sure the wrist strap is tight around your arm.

Caution: The system’s internal components are sensitive to static electricity. Handle the parts carefully, and wear the wrist strap to avoid the flow of static electricity.

2. Disconnect the SCSI cable from the connector on the back of the 5-1/4" drive tray, as shown in Figure 3-13.
3. Use a phillips screwdriver to loosen the two screws holding the 5-1/4" drive tray to the chassis.

Note: If there is a drive installed, there is no need to remove the drive from the tray.

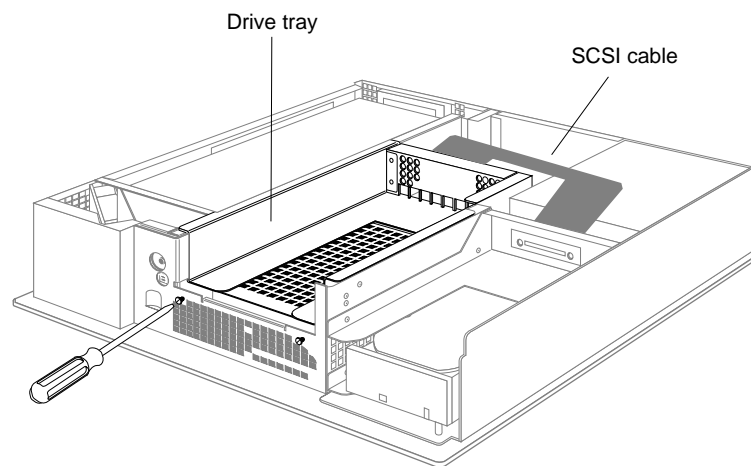

Figure 3-13 Loosening the Screws on the 5-1/4" Drive Tray

- 4. Push the drive tray assembly backward, and pull up to remove it, as shown in Figure 3-14.

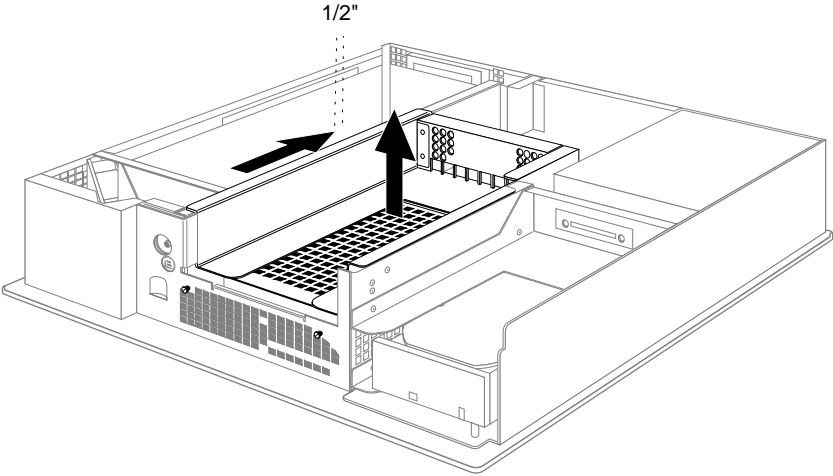

Figure 3-14 Removing the 5-1/4" Drive Tray From the Indigo² Chassis

Removing the Memory SIMMs

To remove the memory SIMMs, follow these steps:

1. Make sure your wrist strap is attached to a metal part of the system and the elastic is secure around your arm.
2. Remove the SIMMs.

- Face the back of the system.
- Locate the memory SIMMs you want to remove.

Note: In order to replace a faulty SIMM, you need to remove the SIMM closest to you first, then remove the following SIMMs until you reach the SIMM you want to replace.

- Use the SIMM removal tool that came with your SIMMs. Place the flat side of the tool against the side of the SIMM (as shown in Figure 3-15) and press down on the latches on each side of the SIMM.

The SIMM releases and tips toward you about 45 degrees.

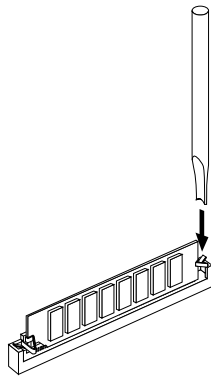

Figure 3-15 Removing a SIMM

- Pull the SIMM out of the socket.
- Remove the other SIMMs.

To replace the SIMMs, turn to “Installing the SIMMs” on page 51.

Replacing the 5-1/4" Drive Tray

If you removed the drive tray, follow these steps to replace it:

1. Make sure your wrist strap is attached to a metal part of the system and the elastic is secure around your arm.
2. Replace the 5-1/4" drive tray assembly.
 - Position the drive and tray so the tabs on the sides of the tray fit inside the slot openings in the chassis, and the open side of the tray faces the front of the system. (See Figure 3-16.)
 - Push the tray forward about a 1/2" to lock it in place.
 - Tighten the two captive screws.
 - Reattach the SCSI cable to the connector on the back of the drive tray.

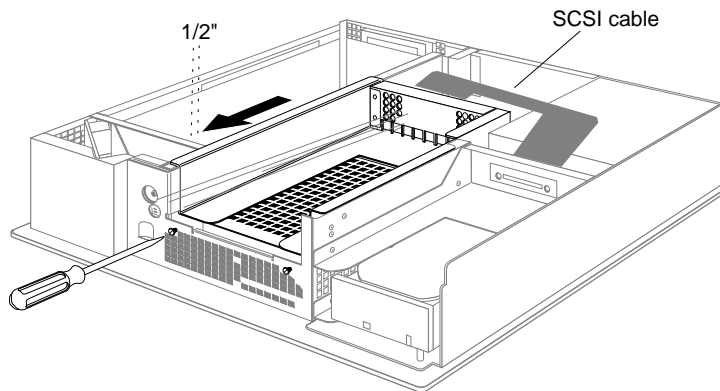

Figure 3-16 Replacing the 5-1/4" Drive Tray in the Indigo² Chassis

Replacing the Cover

To replace the cover, follow these steps:

1. Place the prongs on the underside of the cover into the slots under the top ridge of the backplane of the chassis, as shown in Figure 3-17.
2. Lower the cover onto the chassis until it snaps into place.

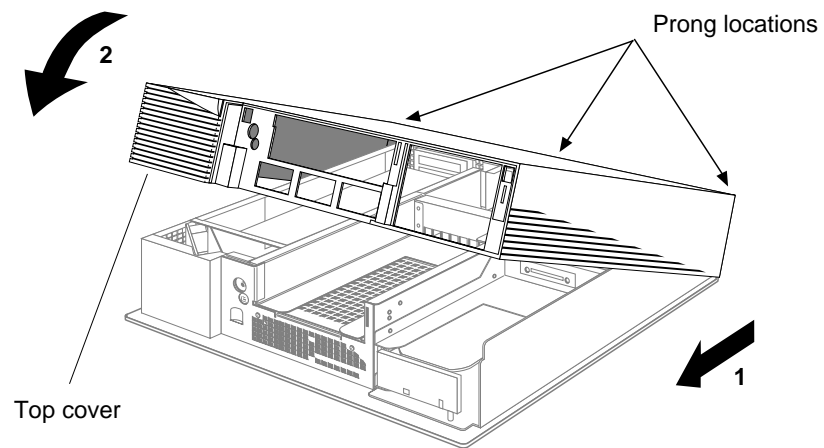

Figure 3-17 Replacing the Top Cover on the Indigo² Chassis

3. Replace the front bezel.
 - Place the tabs on the bottom of the bezel in the grooves in the front of the chassis, as shown in Figure 3-18.
 - Tilt the bezel up until it snaps into place.

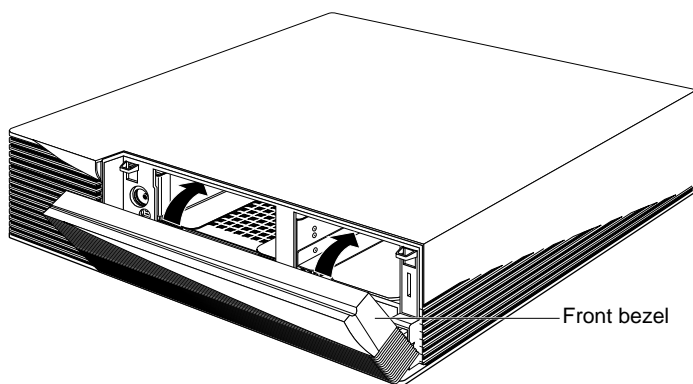

Figure 3-18 Replacing the Front Bezel on the Indigo² Chassis

4. Reconnect the power cable to the connector on the back of the Indigo² chassis.

You are finished removing the SIMMs and are ready to power up the system.

Installing and Removing EISA Boards

This chapter describes how to install and remove Extended Industry Standard Architecture (EISA) expansion boards in your Indigo² workstation.

Installing and Removing EISA Boards

This chapter tells you how to install and remove EISA (Extended Industry Standard Architecture) boards. EISA boards are expansion boards that add functionality to your system through a standard bus.

Note: PC software device drivers are not compatible with the Indigo² workstation.

Installing EISA Boards

To install an EISA board, you must shut down the system, remove the cover, install the EISA board, and replace the cover.

Shutting Down and Powering Off the System

To shut down and power off the system, follow these steps:

1. Open the front cover.
2. Press and release the power switch on the front of the system to shut down the software and power off the system.

The system powers off automatically.

3. Disconnect the power cable from back of the system.

Removing the Cover

To remove the cover, follow these steps:

1. Remove the front bezel.
 - Press down on the tabs on each side of the bezel, as shown in Figure 4-1.
 - Pull the bezel down and away from the chassis.

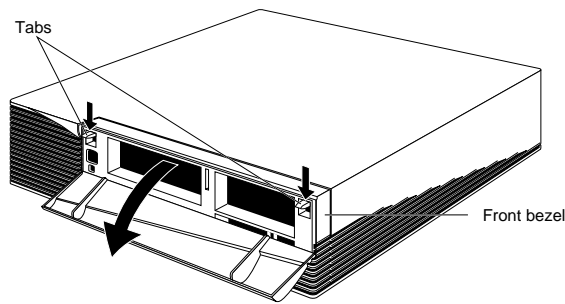

Figure 4-1 Removing the Front Bezel from the Indigo² Chassis

2. Remove the top cover.
 - Press up on the tabs on each side of the drive openings and pull up on the cover.
 - Rotate the cover back and away from the chassis, as shown in Figure 4-2.

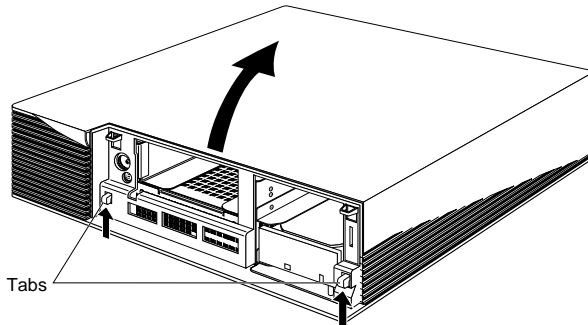

Figure 4-2 Removing the Top Cover From the Indigo² Chassis

Installing the EISA Board

To install the EISA board, follow these steps:

1. Ground yourself to a metal part of the Indigo² chassis.

Caution: The EISA board is extremely sensitive to static electricity; you must wear the wrist strap while installing it. The wrist strap prevents the flow of static electricity, which could damage the board.

- Put the wrist strap over your wrist, making sure it is tight against your arm.
- Attach its alligator clip to a metal part of the Indigo² chassis.

2. Move the system or position yourself so that you are facing the EISA slots.

The EISA slots are located on the left side of the system, behind the internal fan, as shown in Figure 4-3.

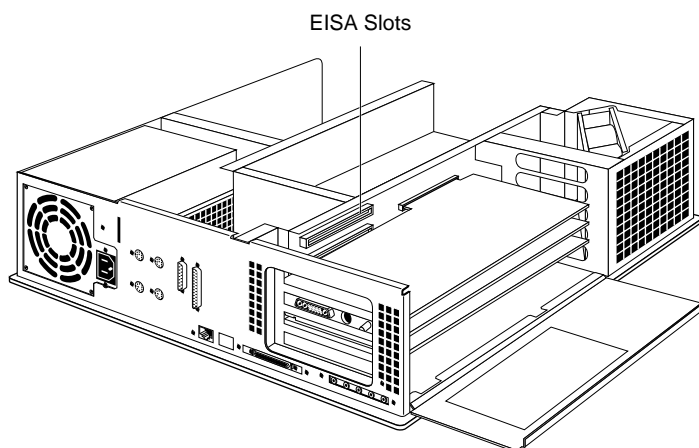

Figure 4-3 Locating the EISA Slots

3. Open the metal panel located in front of the EISA slots by pulling up on the door and lowering it, as shown in Figure 4-4.

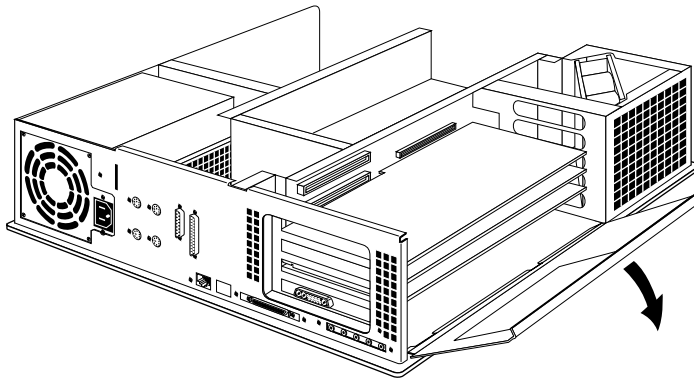

Figure 4-4 Opening the Metal Panel in Front of the EISA Slots

4. Remove the small cover that covers the slot in the back of the system in which you are installing the EISA board.
 - Remove the screw that attaches the cover to the system. The screw is located inside the system on the outer end of the cover.

5. Install the board.
 - Align the right side of the board with the metal grooves on the right.
 - Align the connector on the left side of the board with the connector opening on the left. Push the board into the slot until the connector on the back of the board is securely connected to the port on the backplane, as shown in Figure 4-5.
6. Insert and tighten the screw that holds the board to the chassis.

The screw opening is located on the metal bracket on the upper left side of the board.

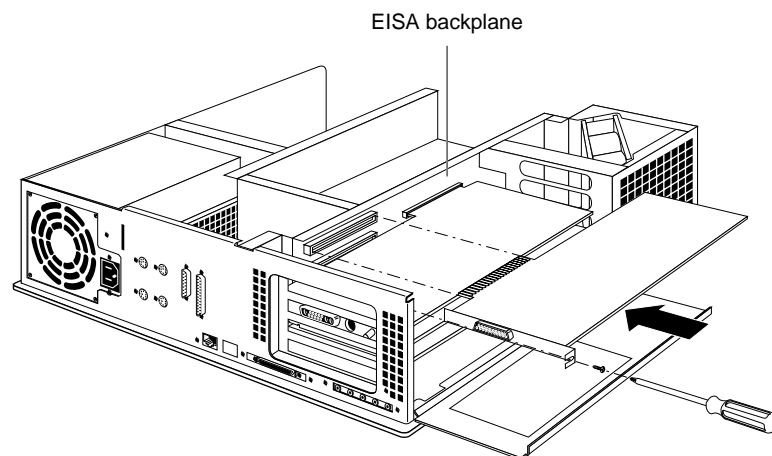

Figure 4-5 Installing the EISA Board

7. Tip the metal panel up until it snaps into place, as shown in Figure 4-6.

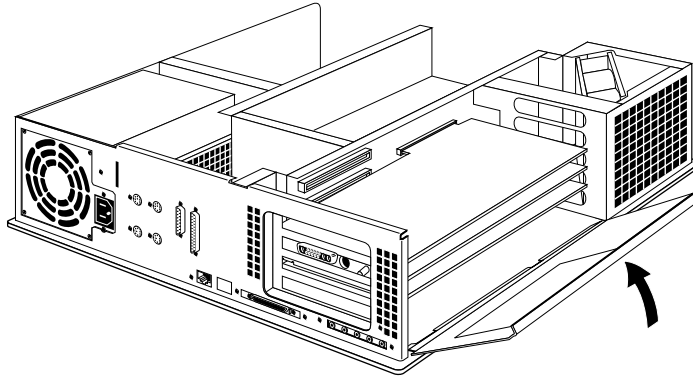

Figure 4-6 Closing the Metal Panel in Front of the EISA Slots

Replacing the Cover

To replace the cover, follow these steps:

1. Place the prongs on the underside of the cover into the slots under the top ridge of the backplane of the chassis, as shown in Figure 4-7.
2. Lower the cover down onto the chassis until it snaps into place.

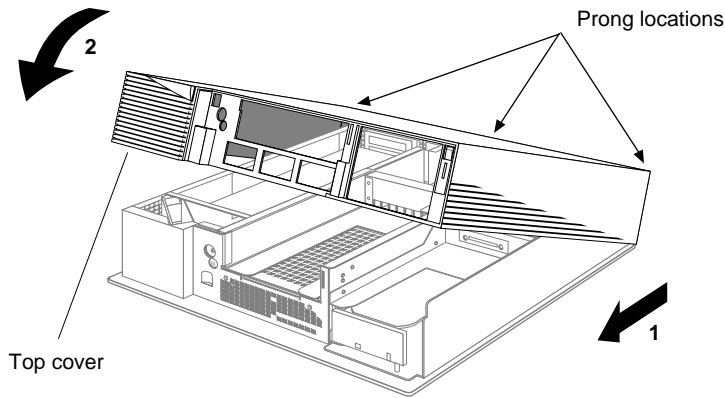

Figure 4-7 Replacing the Top Cover of the Indigo² Chassis

3. Replace the front bezel.
 - Place the tabs on the bottom of the bezel in the grooves in the front of the chassis, as shown in Figure 4-8.
 - Tilt the bezel up until it snaps into place.

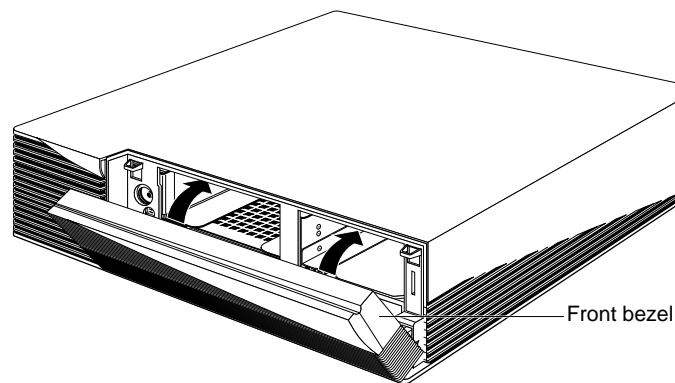

Figure 4-8 Replacing the Front Bezel on the Indigo² Chassis

4. Reconnect the power cable to the connector on the back of the system.

You are finished installing the EISA board and are ready to start up the system.

Removing EISA Boards

To remove an EISA board from the Indigo² chassis, you must shut down the system, remove the cover, remove the EISA board, and replace the cover.

Shutting Down and Powering Off the System

To shut down and power off the system, follow these steps:

1. Open the front cover.
2. Press and release the power switch on the front of the system to shut down the software and power off the system.

The system powers off automatically.

3. Disconnect the power cable from back of the Indigo².

Removing the Cover

To remove the cover, follow these steps:

1. Remove the front bezel.
 - Press down on the tabs on each side of the bezel, as shown in Figure 4-9.
 - Pull the bezel down and away from the chassis.

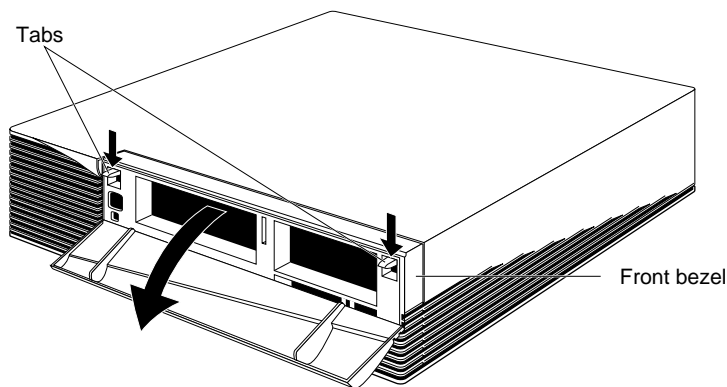

Figure 4-9 Removing the Front Bezel From the Indigo² Chassis

2. Remove the top cover.
 - Press up on the tabs on each side of the drive openings and pull up on the cover.
 - Rotate the cover back and away from the chassis, as shown in Figure 4-10.

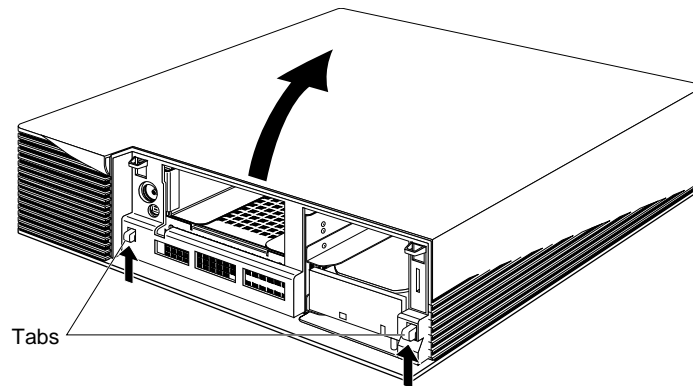

Figure 4-10 Removing the Top Cover From the Indigo² Chassis

Removing the EISA Board

To remove the EISA board, follow these steps:

1. Ground yourself to a metal part of the Indigo².
 - Put the wrist strap over your wrist making sure it is tight against your arm.
 - Attach its alligator clip to a metal part of the Indigo².

Caution: The EISA board is extremely sensitive to static electricity; you must wear the wrist strap while installing it. The wrist strap prevents the flow of static electricity, which could damage the board.
2. Move the system or position yourself so that you are facing the EISA slots.

The EISA slots are located on the left side of the system, behind the internal fan.
3. Open the metal panel located in front of the EISA expansion slots by pulling up on the panel and lowering it down, as shown in Figure 4-11.

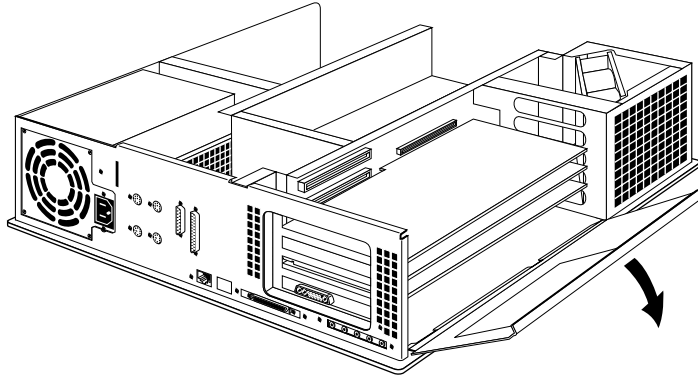

Figure 4-11 Opening the Metal Panel in Front of the Expansion Slots

4. Remove the screw attaching the EISA board to the system slot, as shown in Figure 4-12.

The screw is located on the upper left side of the board.

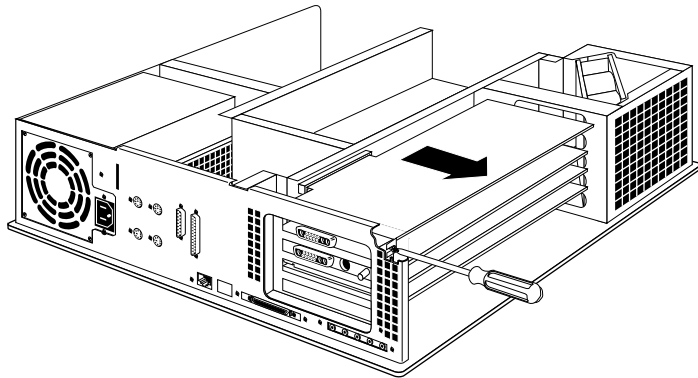

Figure 4-12 Removing the EISA Board From the Indigo² Chassis

5. Pull the board out of the system.
 - Grasp the board with both hands, and pull it out of the slot.
 - Set the board down on a flat, antistatic surface so that the side with the chips on it faces up.

Replacing the Cover

To replace the cover on the Indigo² chassis:

1. Place the back of the cover into the grooves in the back of the chassis, as shown in Figure 4-13.
2. Lower the cover down onto the chassis until it snaps into place.

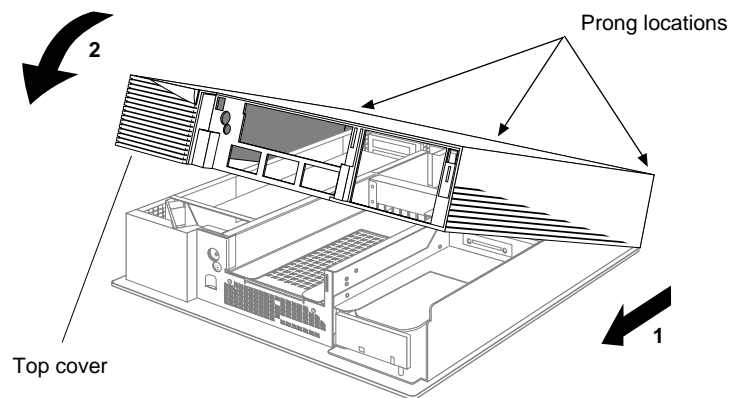

Figure 4-13 Replacing the Top Cover on the Indigo² Chassis

3. Replace the front bezel.
 - Place the tabs on the bottom of the bezel in the grooves in the front of the chassis, as shown in Figure 4-14.
 - Tilt the bezel up until it snaps into place.

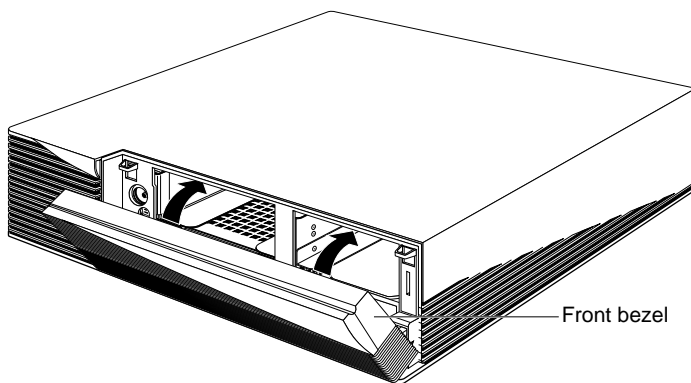

Figure 4-14 Replacing the Front Bezel on the Indigo² Chassis

4. Reconnect the power cable to the connector on the back of the system.
- You are finished removing the EISA board and are ready to power up the system.

Installing Peripherals

This chapter describes how to install internal drives in your Indigo² workstation and how to connect external audio and SCSI devices.

Installing Peripherals

This chapter tells you how to install:

- internal drives
- external SCSI drives
- serial devices
- audio devices

To install a peripheral, you'll first install the hardware, then bring up the system software so that the system can recognize the peripheral.

Installing an Internal Drive

This section tells you how to install internal drives in the Indigo² workstation. Internal drives include the system disk drive, a secondary hard disk drive, a floppy drive, a CD-ROM, a tape drive, and a DAT drive.

Caution: Drives can be easily damaged. Handle your drive carefully. Do not drop it or otherwise abuse it.

Shutting Down and Powering Off the System

To shut down and power off the system, follow these steps:

1. Open the front cover.
2. Press and release the power switch on the front of the system to shut down the software and power off the system.

The system powers off automatically.

3. Press the monitor power switch to turn off your monitor.
4. Disconnect the power cable from back of the Indigo2.

Removing the Front Bezel

To remove the front bezel, follow these steps:

1. Press down on the tabs on each side of the bezel, as shown in Figure 5-1.
2. Pull the bezel away from the chassis.

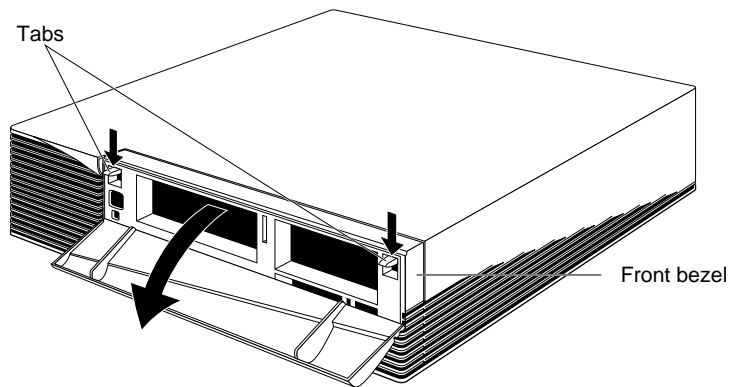

Figure 5-1 Removing the Front Bezel From the Indigo² Chassis

Installing the Drive

To install a drive, follow these steps:

1. Choose a slot in which to install the drive. The slots are shown in Figure 5-2.

Caution: Install only the system disk in the bottom slot.

- Install a hard disk, floppy drive, or a DAT drive in the 3-1/2" drive slot above the system drive slot.
- Install a hard disk, CD-ROM, or QIC tape drive in the 5 1/4" drive slot on the left. Do not use 3-1/2" drives with removable media (such as floppy or DAT) in this slot, or the system cooling may not work correctly.

Note: If you are upgrading drives from the Indigo R3000® or Indigo R4000™ workstation to the Indigo² workstation, 1.2 gigabyte drives with the following part numbers will not fit on the Indigo² drive sled: SD3-S12-4.05, SD3-S12X-4.05, SD7-S12-4.05, SD7-S12X-4.05, P3-D12S, and P7-D12S.

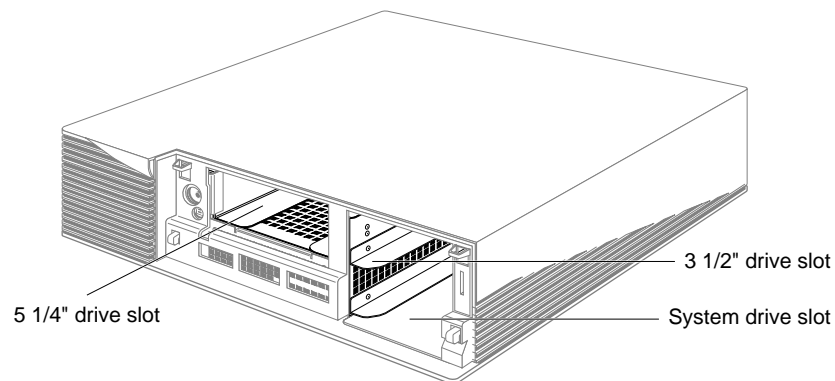

Figure 5-2 Locating the Drive Slots in the Front of the Chassis

2. Install the drive, as shown in Figure 5-3.
 - Pick up the drive so that the lever is facing you and is on the bottom of the drive.
 - Slide the drive into the slot, making sure that the guides underneath the drive line up with the guides in the Indigo² chassis. As you slide the drive in, the lever moves to the right.
 - Push the drive in firmly until you feel solid resistance.
 - Push the lever all the way to the right. This locks the drive in place. The lever should be flush with the front of the drive.

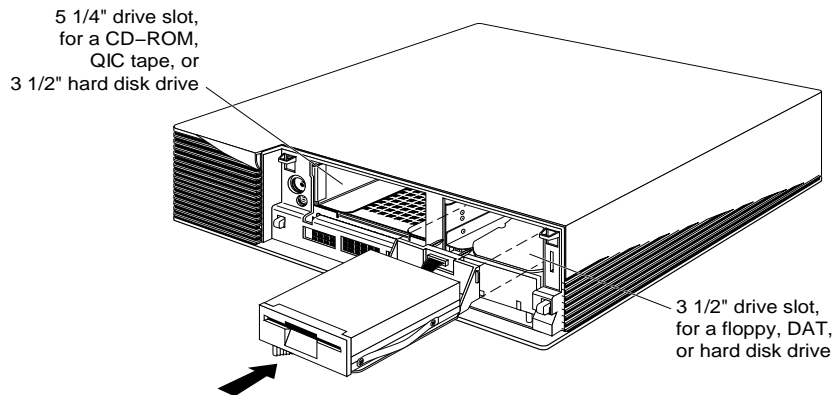

Figure 5-3 Installing an Internal Drive

Replacing the Cover and Turning On the Power

To replace the cover, follow these steps:

1. Remove the blanking panel from the front bezel.

This allows you to insert media into the drive without removing the bezel.

 - Push the blanking panel out from the back of the bezel. The panel falls out. Save the panel in case you ever remove and do not replace your drive.
2. Replace the top cover.

- Place the prongs on the underside of the cover into the slots under the top ridge of the backplane of the chassis, as shown in Figure 5-4.
- Lower the cover onto the chassis until it snaps into place.

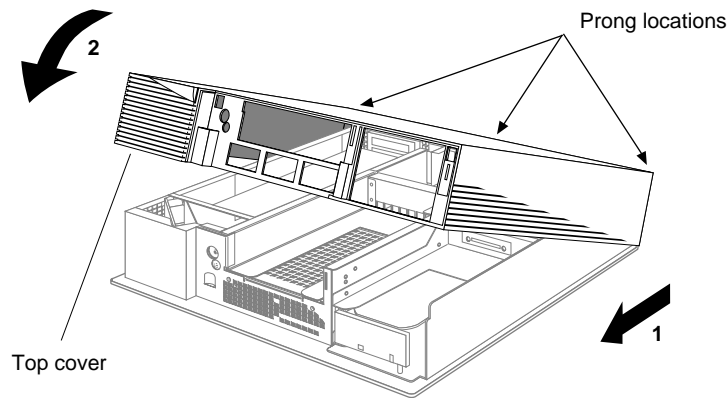

Figure 5-4 Replacing the Top Cover on the Indigo² Chassis

3. Replace the front bezel.
 - Placing the tabs on the bottom of the bezel in the grooves in the front of the chassis, as shown in Figure 5-5.
 - Tip the bezel up until it snaps into place.

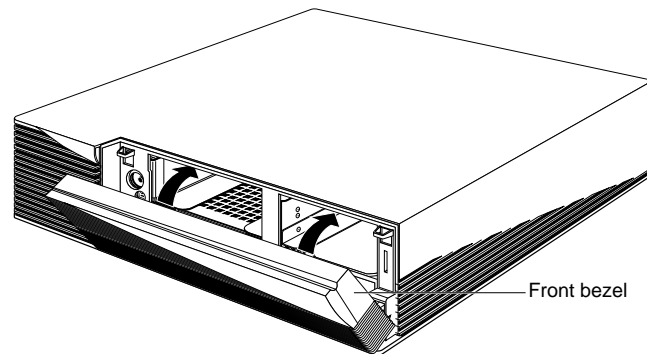

Figure 5-5 Replacing the Front Bezel on the Indigo² Chassis

4. Press and release the power switch on the front of the Indigo² chassis.

When you see the login screen, you are ready to log in. Go to the next section.

Testing the Internal Drive

The system automatically sets up the system software for most internal devices you install and places an icon on the desktop.

Once you install the drive, follow these steps to check that the system recognizes the new drive.

1. Log in to your account. For more information on logging in, refer to “Logging In to the Workstation” on page 31.
2. If the device is installed correctly, you should see an icon for it on the desktop. Double-click the icon to set up the drive.
3. You can also use the System Manager to check that the drive is shown correctly.
 - From the System toolchest, select “System Manager.” You see a window showing Hardware and Shared Resources.
 - Pull down the Hardware menu and select “Disks.” You see a list of installed drives.

If the drive you installed does not appear, power down the system and make sure the drive is installed all the way in the slot. Then restart the system and check the System Manager listing again.

If You Installed a CD-ROM Drive

If other users are going to access your CD-ROM drive, refer to the online *Personal System Administration Guide* for special instructions. Select “Online Books” from the Help Toolchest. Then select the *Personal System Administration Guide*, and search for “Setting Up SCSI Peripherals.”

If You Installed a Floppy or Floptical Disk Drive

If you are using the drive as an IRIX device, follow these steps to format a floppy or floptical disk, if necessary:

1. Choose “Disk Manager” from the System toolchest.
You see a photo of the drive with a labeled button underneath it.
2. Click the button beneath the photo of your floppy or floptical drive.
You see the “Disk Information” window.
3. Click the “Initialize” button.

Floppy disks take about 2 minutes to format; floptical disks take about 10 minutes.

For more information on formatting disks, select “Online Books” from the Help toolchest and search for “Formatting Floppy and Floptical Disks” in the *Personal System Administration Guide*.

You are finished formatting the floppy or floptical disk.

Ejecting a Floppy or Floptical Disk

Follow these steps to eject a floppy or floptical disk from the disk drive.

1. On your *desktop*, make sure the *floppy* or *floptical* icon is selected.
2. Press the right mouse button, and select “Eject Floptical.” Or, from the Selected toolchest, choose “Eject Floptical.”

If You Installed a Tape Drive

The software automatically recognizes any tape drives you install. The tape drive is ready to use.

For information on backing up data onto a tape, select “Online Books” from the Help toolchest. Then select the *Personal System Administration Guide*, and search for “Backing Up and Restoring Files.”

Cleaning DAT Drives

If you use your DAT drive frequently, magnetic dust or debris can collect on the heads of the drive. This can make your DAT tapes unreadable or unwritable.

If the green LED on the front of the DAT drive flashes at about 5-second intervals, you should clean the DAT drive heads. You should clean your DAT drive after about every 30 hours of use.

Follow these steps to clean your DAT drive:

1. Insert a Datagrad cleaning DAT tape.

Note: Be sure to use a data cleaning tape only. An audio cleaning tape does not work. Use a cleaning DAT tape authorized by the DAT drive manufacturer.

The drive loads the tape and starts cleaning the heads.

2. After about 10 seconds, the drive ejects the tape.

Note: If the LED on the front of the DAT drive still flashes after you have cleaned the drive heads, you may have a worn out cleaning DAT tape. Try using a new cleaning DAT tape.

Removing Internal Drives

For instructions on removing internal drives, go to “Replacing Internal Drives” on page 184.

If you remove a secondary hard drive or floppy drive and do not intend to replace it, you need to inform the system that the drive is no longer there. For more information, select “Online Books” from the Help toolchest, and search for “Removing a Disk” in the *Personal System Administration Guide*.

Installing External SCSI Devices

This section explains how to connect external SCSI devices to the Indigo² workstation. External devices include a QIC tape drive, CD-ROM drive, SCSI scanners, or other external SCSI devices.

Follow the steps below to connect an external SCSI device to your Indigo².

Assigning a SCSI Address to the External Device

Before shutting down your system and installing an external device, you need to assign an address to the device.

- If you currently do not have any extra internal devices or external devices attached to your system, you can assign any number from 1 to 7 to the new device. Do not use address 0, as this is the system SCSI ID. Skip to “Setting the SCSI Address on the External Device.”
- If you have at least one or more internal or external devices attached to your system and you are adding another device, you must check which addresses are assigned to the existing external devices and then choose a number between 1 and 7 that has not already been assigned.

To check available addresses for external devices, follow these steps:

1. If the Indigo² is powered off, turn on the system power.
 - Open the front cover by snapping it away from the top edge of the chassis and tipping it down.
 - Press and release the power switch to turn on the system.
2. Log in to your account. For more information on logging in, refer to “Logging In to the Workstation” on page 31.
3. When the system comes up, select “System Manager” from the System toolchest.
4. Pull down the Hardware menu and select “Summary.”

You see a listing of your system’s hardware devices and their address numbers.
5. Choose a number from 1 to 7 that is not assigned to your current devices and then go to the next section, “Setting the SCSI Address on the External Device.”

Setting the SCSI Address on the External Device

Now you must manually set the address you chose in step 5 above on the external device.

This is done in a number of ways, depending on the device. Most SCSI devices have a push-button switch, dial, or jumpers that you set to determine the SCSI address.

If the device has a switch or dial on the back, follow the steps below. If there is no switch or dial on the device, see the instructions included with the device.

1. Take the device out of its box and locate the push-button switch or address dial. It may be on the rear or bottom of the device.
2. Use a small screwdriver or pencil tip to set the dial or push the buttons to assign the address number you chose in step 5.

Caution: Do not assign number 0! This number is reserved for the SCSI controller.

Attaching the Device

You can attach one or more external devices to the SCSI port on the back of your workstation. Connecting more than one device is called *daisy chaining*. The devices are connected together in a chain, with the first device attached to the SCSI port on the workstation. If any of the external devices are FAST SCSI-2, do not daisy-chain more than two devices.

If one or more of the devices you are attaching to your workstation is a FAST SCSI-2 device, then the maximum combined cable length of all SCSI cables should not exceed 3 meters. If you are not attaching any FAST SCSI-2 devices, then the maximum combined cable length of all SCSI cables should not exceed 6 meters.

Additionally, if any of the external devices are FAST SCSI-2, it is extremely important that you use a cable of controlled impedance, and with impedance-matched connectors. Not all cables with the correct connector will work. This is particularly important if you have more than one external device.

Note: Use the cables and active terminator that came with the FAST SCSI-2 device, or purchase an active terminator, if necessary. You must use an active terminator. (The terminator provided with the system is an active terminator.) Using other types of cables or terminators can result in data loss. If you have a device that you want to attach to your system, but you do not have the appropriate cables, you can order them by contacting your service provider.

To attach an external device, follow these steps:

1. Shut down and power off the system.
 - Open the front cover.

- Press and release the power switch on the front of the system to shut down the software and power off the system.
The system powers off automatically.
 - Press the monitor power switch to turn off your monitor.
2. Remove the active SCSI terminator from the workstation or from the last external device attached to your workstation.
- If you are attaching the device to the workstation, remove the terminator from the SCSI connector on the Indigo² chassis by squeezing the clips on both sides of the terminator and pulling it off. (See Figure 5-6.) Save the terminator. You must reattach it to the SCSI connector if you remove and do not replace the external device.

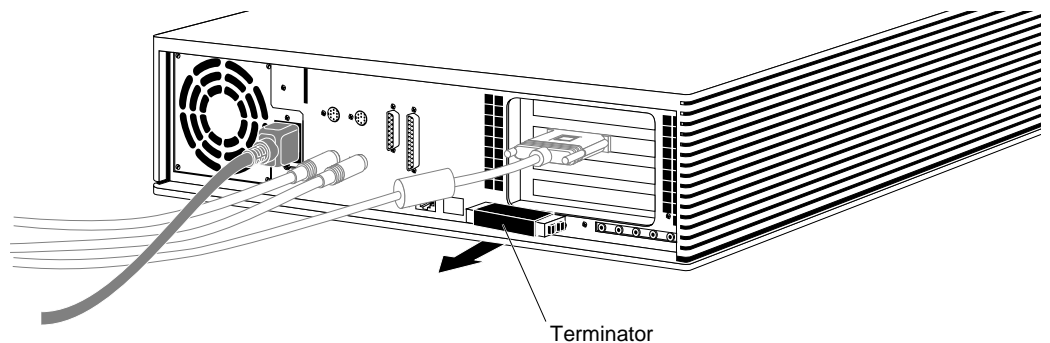

Figure 5-6 Removing the Terminator From the Indigo² Workstation

- If you are daisy-chaining a device to another device, remove the terminator from the connector on the last device in the chain by squeezing the clips on both sides of the terminator and pulling it off. (See Figure 5-7.)

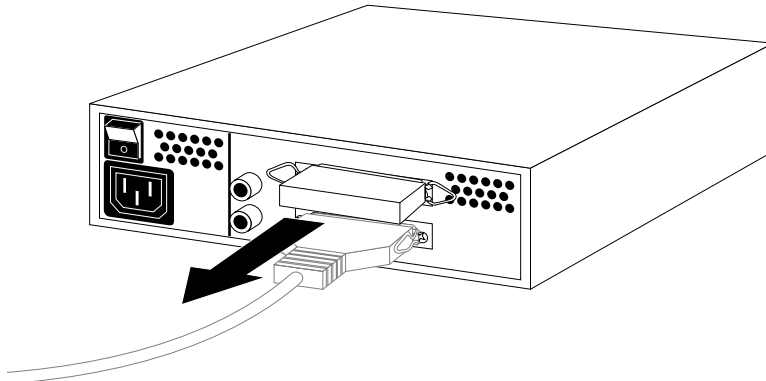

Figure 5-7 Removing the Terminator From the Last Device on the Daisy-Chain

3. Attach the appropriate SCSI cable. Silicon Graphics devices ship with two cables; one with identical connectors at each end, and one with different connectors at each end.
 - If you are attaching the device to the workstation, use the cable that has a different connector on each end. Attach the flat, smaller end of the cable to the SCSI port on the workstation, as shown in Figure 5-8.
 - Connect the other end of the SCSI cable to one of the SCSI connectors on the back of the device and secure the clips on each side of the connector.

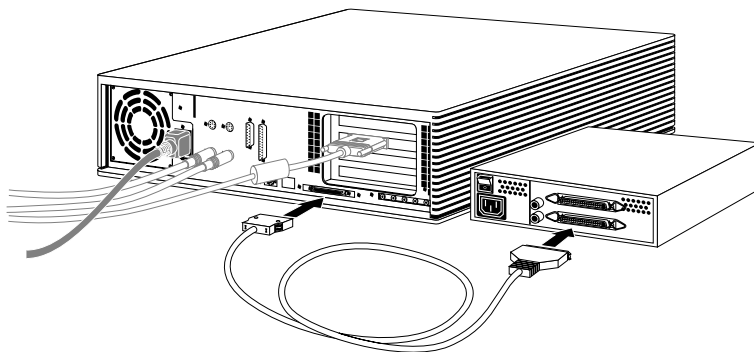

Figure 5-8 Connecting an External SCSI Device to the Indigo² Chassis

- If you are daisy-chaining a Silicon Graphics device to another Silicon Graphics device, use the cable that has identical connectors at each end. (The connectors on the cable must match the connectors on the devices you are attaching.)
- Connect one end of the cable to the open connector on the first device, as shown in Figure 5-9.
- Attach the other end to one of the connectors on the device you are adding.

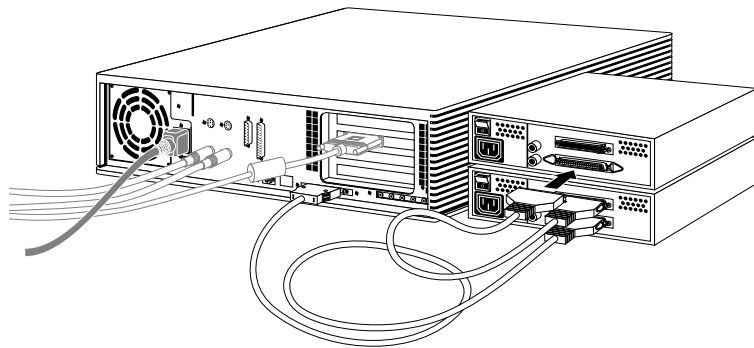

Figure 5-9 Daisy-chaining an External SCSI Device to Another External SCSI Device

4. Gently place the terminator you received with the device onto the open SCSI connector on the back of the last device on the daisy-chain, as shown in Figure 5-10, and secure the clips on each side of the terminator.

The SCSI connector is designed so that you can put the terminator on only one way, if not forced.

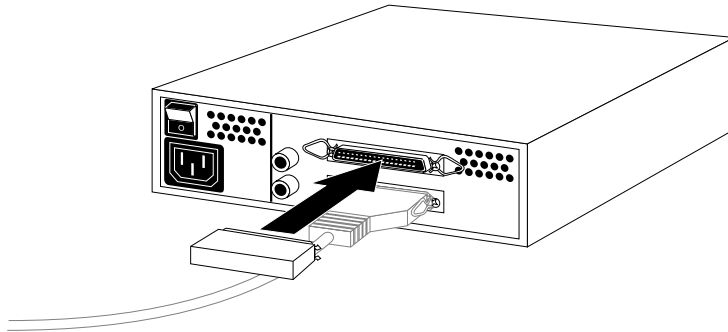

Figure 5-10 Attaching a Terminator to an External SCSI Device

5. Connect one end of the power cable that came with your device to the power connector on the back of the device, as shown in Figure 5-11.

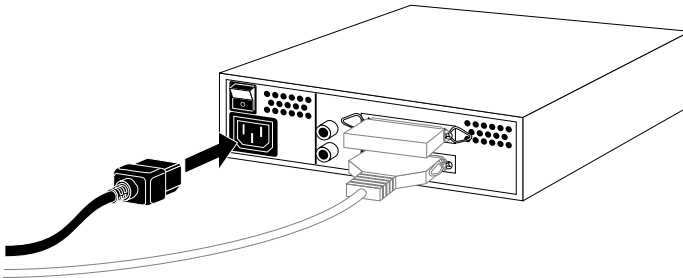

Figure 5-11 Connecting the Power Cable to an External Device

6. Plug the other end of the power cable into a grounded three-pronged electrical outlet.

Note: Remember to turn on the external devices first and then your system to make sure the devices are recognized.

You are now ready to power up your system and check to make sure that the device is recognized.

Testing the External Device

After you've attached the device to your system, check to make sure your system recognizes the device.

The system automatically sets up the system software for most external devices you install and places an icon on the desktop.

To check the system configuration, follow these steps:

1. Turn on the external device first. External devices can be turned on in any order, as long as you turn them on before the system. The power switch is on the back of the device.

Hint: Always turn on the external device *before the system*; otherwise, the system does not recognize the device.

2. If the Indigo² is powered off, turn on the system power.
 - Open the front cover by snapping it away from the top edge of the chassis and tipping it down.
 - Press and release the power switch to turn on the system.

After a few moments, the system starts up.

3. When you see the login screen, log in to your account. For more information on logging in, go to “Logging In to the Workstation” on page 31.

If the device is installed correctly, you see an icon for it on the desktop. Figure 5-12 shows the icon for a CD-ROM drive.



Figure 5-12 CD-ROM Icon

You can also use the System Manager to check that the drive is shown correctly.

1. From the System toolchest, select “System Manager.” You see a window showing Hardware and Shared Resources.
2. Look for the device you installed under Shared Resources.

If the device you installed does not appear, do the following:

1. Power down the system.
2. Check that you’ve connected the correct SCSI cable to the drive.
3. If the drive is the last SCSI device on the daisy-chain, make sure it has a terminator installed on it.
4. Restart the system and check the System Manager listing again

If You Installed a Floppy or Floptical Drive

If you are using the drive as an IRIX device, see “If You Installed a Floppy or Floptical Disk Drive” on page 89 for instructions on formatting and ejecting a floppy disk.

If You Installed a CD-ROM Drive

The software automatically recognizes any CD-ROM drives you install. If other users are going to access your CD-ROM drive, refer to the online *Personal System Administration Guide* for special instructions. Select “Online Books” from the Help Toolchest. Then select the *Personal System Administration Guide*, and search for “Setting Up SCSI Peripherals.”

If You Installed a Tape Drive

The software automatically recognizes any tape drives you install. The tape drive is ready to use.

For information on cleaning DAT drives, see “If You Installed a Tape Drive” on page 89.

For information on backing up data onto a tape, select “Online Books” from the Help toolchest. Select the *Personal System Administration Guide*, and search for “Backing Up and Restoring Files.”

If You Installed a Printer

If you installed a printer, select “Printer Manager” from the System toolchest, and set up the printer. For more information on setting up the printer, select “Online Books” from the Help toolchest. Select the *Personal System Administration Guide*, and search for “Setting Up Network, Peripheral, and Printer Connections.”

Installing Serial Devices

This section tells you how to install serial devices. Serial devices include:

- dial and button boxes
- dials box
- digitizer tablet
- console terminals
- modems

Attaching the Device

To install a serial device, follow these steps:

1. Unpack the serial device and cables.
2. Locate the serial ports on the back of the Indigo² chassis, as shown in Figure 5-13.

The serial ports are labeled **1** and **2** and are MINIDIN 8 connectors.

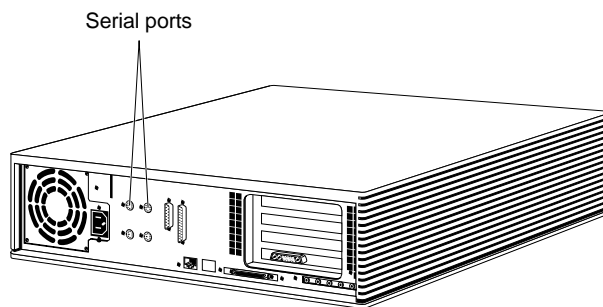

Figure 5-13 Locating the Serial Ports on the Back of the Indigo² Chassis

3. Plug in the serial cable.

If you are attaching a console terminal, attach it to serial connector 1 only. If you are attaching any other device, you can attach it to either connector.

- Plug one end of the serial cable into the connector on the back of the serial device.
- See the instructions that came with the serial device for detailed instructions on how to connect the cable to the device.
- Plug the other end of the cable to the serial connector on the back of the Indigo2 chassis, as shown in Figure 5-14.

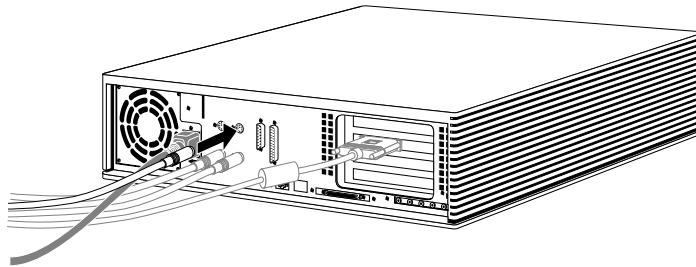

Figure 5-14 Connecting the Serial Cable to the Serial Port on the Indigo2 Workstation

Note: If you are installing a dial and button box, a small serial adapter cable came with the box. First connect the serial adapter cable to the serial cable. Then connect the other end of the serial adapter cable to the Indigo² chassis.

4. Plug in the serial device's power cable, (if any).

- Plug the socket end of the power cable into the power connector on the back of the serial device.
- Plug the other end into a grounded three-pronged wall outlet or power strip. (Do not use a two-pronged adapter.)

Note: For information on using other serial cables, see "Other Serial Cables" on page 102.

Configuring the Device

Once the device is connected to the workstation, you need to configure it. Select “Online Books” from the Help toolchest. Select the *Personal System Administration Guide*, and search for “Setting up Serial Peripherals.”

Other Serial Cables

You may want to connect other serial devices to your Indigo². Below you’ll find information on which serial cables you can use with your Indigo².

Printer/Dumb Terminal Serial Cable

To use serial printers and dumb terminals, use a 3-wire standard Macintosh[®] (Plus, SE, or II) to ImageWriter[®] I cable. (The ImageWriter II cable does not work.) The cable connector pinout assignments for this cable are shown in Table 5-1.

Table 5-1 Cable Connector Pinout Assignments for Printer/Dumb Terminal Serial Cable

Signal Description	Pin Number DIN-8 Connector (male)	Pin Number DB-25 Connector (male)
	1	N/C
	2	N/C
TXD	3	3
GND	4	7
RXD	5	2
	6	N/C
	7	N/C
GND	8	7

Note: For a 3-wire cable and no hardware flow control modem, you must use the `/dev/ttyd*` command devices in the configuration files. For more detailed information, see the *serial* man page. To access the man page, place the cursor in the console window and type

```
man serial
```

Modem Cable

Use a full-handshake (includes RTS and CTS) serial cable for a modem with RTS/CTS flow control. You can use this cable for all serial devices except terminals and serial printers (any application that doesn't need RTS flow control). For example, you can use this cable for a 3-wire application. It can be used with a null modem adapter for serial printers and dumb terminals. You can purchase the full-handshake serial cable from Silicon Graphics or your local service provider.

The cable connector pinout assignments are shown in Table 5-2.

Note: Do not use a standard Macintosh serial cable. It does not have the correct number of connectors for full flow control.

Table 5-2 Cable Connector Pin Assignments for a Modem Cable

Signal Description	Pin Number DIN-8 Connector (male)	Pin Number DB-25 Connector (male)
DTR	1	20
CTS	2	5
TXD	3	2
GND	4	7
RXD	5	3
RTS	6	4
DCD	7	8
GND	8	7

Note: If you are attaching a modem with modem signals and RTS/CTS flow control, you must use the `/dev/ttyf*` command devices in the configuration files. For more detailed information, see the *serial* man page. To access this man page, place the cursor in the console window and type

```
man serial
```

Serial Devices Using a Silicon Graphics Adapter Cable

To use the devices below, you'll need a serial adapter cable supplied by Silicon Graphics.

- dial and button box
- dials box
- digitizer tablet
- Spaceball™

The Silicon Graphics adapter cable is used to convert the serial cable that came with the device to a Silicon Graphics DIN-8 serial cable connector. This cable then connects to the serial connector on the back of the Indigo² chassis. The cable connector pinout assignments are shown in Table 5-3.

Table 5-3 Cable Connector Pinout Assignments for the Silicon Graphics Adapter Cable

Signal Description	Pin Number DIN-8 Connector (male)	Pin Number DB-9 Connector (female)
DTR	1	9
CTS	2	5
TXD	3	2
GND	4	7
RXD	5	3
RTS	6	4
DCD	7	8
GND	8	7

Table 5-3 (continued) Cable Connector Pinout Assignments for the Silicon Graphics Adapter

Signal Description	Pin Number DIN-8 Connector (male)	Pin Number DB-9 Connector (female)
	N/C	6
	N/C	1

Serial Devices Using a PC Adapter Cable

To use a serial device designed for use with personal computers using a DB-9 connector, you'll need a PC adapter cable supplied by Silicon Graphics. This adapter cable is used to convert from the PC's DB-9 pinout to the Indigo² workstation's DIN-8 pinout.

The cable connector pinout assignments for the PC adapter cable are shown in Table 5-4.

Table 5-4 Cable Connector Pinout Assignments for the PC Adapter Cable

Signal description	Pin Number DIN-8 (male)	Pin Number DB-9 (male)
DTR	1	4
CTS	2	8
TXD	3	3
GND	4	5
RXD	5	2
RTS	6	7
DCD	7	1
DSR	8	6
	N/C	9

Installing Audio Devices

The following audio ports are located on the back of the Indigo² workstation:

- Microphone In
- Line In
- Line Out
- Headphone Out
- Digital I/O

Audio jacks accept stereo 3.5-mm phone plugs. See Appendix A, “Cable Pinout Assignments,” for cable pinout information.

To connect an audio device, plug the device cable into the appropriate port, as shown in Figure 5-15.

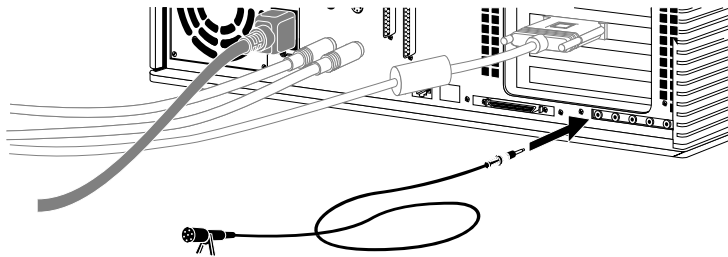

Figure 5-15 Connecting an Audio Device to the Indigo² Workstation

For information on audio tools available on your workstation, choose “Online Books” from the Help toolchest and select the *Media Tools User’s Guide*.

Installing Software

This chapter describes how to install and remove Silicon Graphics software products on your Indigo² workstation.

Installing Software

This chapter describes the software installation tools that you use to install a new version of the operating system, and to install optional software products that you received from Silicon Graphics, Inc. To install products from other vendors, please see the software installation instructions that accompany the products.

You can install software from:

- a CD-ROM drive that's connected either to your own system or to another Silicon Graphics system on your network.
- A remote directory on another Silicon Graphics system or any system that supports *bootp* and *tftp*.

Only the Administrator can install or remove software if there is a password on the Administrator (root) account.

If you need advanced information on software installation or troubleshooting, please see the online *Software Installation Administrator's Guide*.

About the Software Installation Tools

Silicon Graphics, Inc. ships two software installation tools:

- *Inst* is a command-line tool for installing new versions of the operating system. This tool works when the system is running a small version of the operating system (the miniroot) to minimize the possibility of installation errors. You can also use this tool to install optional products that do not require miniroot installation, but Silicon Graphics, Inc. recommends using the graphical Software Manager.
- Software Manager is a graphical tool for installing optional products. This tool works only when the system is up and running; you start it by choosing "Software Manager" from the System toolchest.

Note: Software Manager is available on systems running IRIX release 5.3 and greater.

For more information on installing optional products, see the Software Manager's online help, or choose "Online Books" from the Help toolchest, and see Chapter 4 of the online *Personal System Administration Guide*.

For information on installing a new version of the operating system software, see the next section in this chapter. For detailed information on using *Inst*, see the online *Software Installation Administrator's Guide*.

Installing a New Version of the Operating System Software

The Administrator can install a new version of the IRIX operating system and any optional software by following these steps:

1. Make a full system backup. For more information, select "Online Books" from the Help toolchest and search for "Backing Up and Restoring Files" in the online *Personal System Administration Guide*.
2. If you do not have a CD drive connected directly to your system, find a CD drive on your network.
 - Choose "Disk Drives" from the Search For rollover menu in the Find toolchest.
 - In the Search window, choose "Type" from the Match menu, and choose "CD-ROM" from the menu button next to *whose type is*. See the online help in the Search window for details.
 - Click the *Search* button to find the drive.
 - When the drive's icon appears, it is labeled *systemname:cdrom*. *systemname* is the name of the system to which the drive is connected.

Note: If the search does not find a device that you know is available, choose "Online Books" from the Help toolchest and see "Troubleshooting Network Errors" in the online *Personal System Administration Guide*.

- Contact the administrator of the system to which the drive is connected, and make sure remote installations are allowed from that CD drive. For more information, select "Online Books" from the Help toolchest and search for "Allowing Remote Users to Install Software From Your CD Drive" in the online *Personal System Administration Guide*.

3. Insert the operating system CD into the drive you are going to use.
4. Check the full pathname of the drive.
 - If you're using a drive that's connected to your own system, double-click the drive's icon. The title bar shows the full pathname (for example, */CDROM*); write down the pathname because you will need this in step 7.
 - If you're using a remote drive, double-click its icon. A window appears in which the field labeled "Open Remote Directory" shows the full pathname of the CDROM directory (for example, */CDROM*). Write down the full name, then click the *Cancel* button to close this window.
5. Read and, if you like, print all or part of the online release notes.
 - If you're using a drive that's connected to your own system, double-click the drive's icon, then, in the directory view window that appears, double-click the CDgrelnotes icon to view the release notes. To print all or part of the release notes, choose "Print" from the File menu.
 - If you're using a remote drive, double-click its icon. In the Open Remote Directory window, click the *OK* button, then, in the directory view window that appears, double-click the CDgrelnotes icon to view the release notes. To print all or part of the release notes, choose "Print" from the File menu.

6. Shut down the system, restart it, and start the software installation tool.
 - Choose “System Shutdown” from the System toolchest.
 - When you see the dialog box that says *Are you sure you want to shut down the system right now*, click on the *OK* button.

You see a dialogue box that says *System is Shutting Down*.
 - When you see a dialogue box or message that says *Okay to power off*, click the *Restart* button in the dialogue box, or press any key.
 - When you see a dialogue box or message that says *Starting up the system*, click the *Stop for Maintenance* button, or press <Esc>.
 - Click the icon labeled *Install System Software*.
7. Specify the location of the new software to install.
 - If the CD is in a drive connected to your system, click the *Local CD-ROM* icon. When the notifier appears asking you to insert the CD, insert the CD in the drive, and click *Continue*.
 - If the CD is in a drive that’s connected to another system on the network, click the *Remote Directory* icon. When a notifier appears asking you for the remote hostname, type the system’s name, a colon(:), the full pathname of the CD (which you found in step 4), and add *dist* to the end. For example, to access a CDROM on the system mars, type:

```
mars:/CDROM/dist
```

When the notifier appears asking you to insert the CD, insert the CD in the drive and click *Continue*.

Note: If you see error messages after you specify the location, see “System Cannot Find the New Software” on page 119.

8. When the system finds the software, it takes several minutes to copy the software installation tools onto your system. The system is ready to install software when you see the *Inst* menu:

```
1. from [source]
2. list [keywords] [names]
3. go
4. install [keywords] [names]
5. remove [keywords] [names]
6. keep [keywords] [names]
7. step [keywords] [names]
8. view [args]
9. conflicts [choice...]
10. help [topic]
11. admin
12. quit
```

```
Inst>
```

9. Install all or some of the subsystems that make up the operating system and optional software.

- To install all of the default subsystems, type:

```
go
```

- To install all optional and required subsystems that are available on the CD, type:

```
install all
```

```
go
```

Note: Usually you do not want to install all subsystems, as they occupy a very large amount of disk space. See the online release notes for product sizes.

- To select only required subsystems or to select all required subsystems plus some optional subsystems, see “Choosing Subsystems to Install or Remove” on page 115.

If you see an error message that says the system cannot find the software, see “System Cannot Find the New Software” on page 119. If you see any other messages, see “System Cannot Complete an Installation” on page 120.

During the installation, you see several progress report messages. The installation is complete when you see this message:

```
Installation and removals were successful
```

```
1. Continue with the session
```

```
2. Quit now
Please enter a choice [1]:
```

If you see any other messages, see “System Cannot Complete an Installation” on page 120.

- To quit *Inst*, go on to the next step.
- To install optional software from another CD, press <Enter>. You may see several messages as *Inst* rebuilds its internal data files. Manually eject the CD from your CDROM drive by pushing the eject button; insert the next CD in the drive, then type:

```
from /CDROM/dist
```

Go back to step 7 to install the software.

10. When all the software is installed, quit *Inst* by typing:

```
2
```

You may see several messages as *Inst* communicates your changes to the operating system, and configures the new kernel.

During its exit procedure, *Inst* may “requickstart” your machine. This process synchronizes the libraries and executables on your machine. This process can take up to 20 minutes. During this time you may see these messages:

```
Building one time quickstart database.
Requickstarting necessary files.
Automatically reconfiguring the operating system.
```

11. The software is successfully installed and your system is ready to restart when you see this message:

```
Ready to restart the system. Restart? [y, n]
```

Type **y** then press <Enter>.

If you see a different message or question, see “System Reports Errors After an Installation” on page 121.

The system starts up as usual.

12. When the login window appears, log in to your own account.
13. See your Release Notes by choosing “Release Notes” from the Help toolchest, then by choosing products from the Products menu.

The Release Notes for each product list the directories where applications are stored on your disk so you can drag icons onto your desktop or onto a particular page of the Icon Catalog. The Release Notes also cover new features and known problems with the product.

Choosing Subsystems to Install or Remove

When you are running *Inst*, you can see all the subsystems that make up the products, and check whether they have been selected for installation by typing:

```
list
```

You see one or more screens of information.

- To see the next screen, press the `<spacebar>`.
- To stop the listing, press `<q>`; you see the `Inst>` prompt.
- To see the *Inst* menu again, press `<?>`.
- To see online help, type: `help`

Note: *The remainder of this chapter contains detailed examples of Inst listings and commands that apply to only the IRIX 5.3 version of Inst. If you are running an earlier or later version of Inst, please use the online help that is available by typing help at the Inst> prompt.*

list displays a key to the listing, followed by the list of available subsystems. The first three columns of the listing show:

- whether the available (usually newer) version of a subsystem is selected for installation (i) or is not selected (k)

Note: If you have a version of a subsystem already installed and you would like to remove it while other software is being installed. To do this, type `remove <subsystem>` at the `Inst>` prompt.

- whether the available software is a new product that has never been installed (N), or is an upgrade to (U), is the same version as (S), or is an older version of (O) a product that is already installed. If no character appears in this column, the product has been available for installation before, but has never been installed; it is considered a 'Not Installed' product.

Here are some samples of the first three columns of subsystem listings:

i U nfs.sw.nis
A newer, upgrade version (U) of this subsystem (nfs.sw.nis) is available and is selected for installation (i). It is part of the NFS product (nfs).

k S pfa.sw.lib
An identical (same) version (S) of this subsystem (pfa.sw.lib) is available, so *Inst* assumes you want to keep (k) the currently installed version. It is part of the Power Fortran product (pfa).

k D insight.sw.client
The version of this subsystem (insight.sw.client) that is available is a downgrade (D) to the subsystem that is already installed, so *Inst* assumes you want to keep (k) the currently installed version. It is part of the IRIS Insight product (insight).

i N dmedia_tools.sw.soundtools
The subsystem (dmedia_tools.sw.soundtools) that is available is a new product (N), which means it has never been installed or available for installation before. It is selected for installation (i) because it is a default subsystem. It is part of the Digital Media Tools product (dmedia_tools).

systour.sw.eoe
This subsystem (systour.sw.eoe) has been available for installation before but has never been installed, and it is not selected for installation (no letters precede it). It is part of the System Tour product (systour).

The other columns of the listing show:

- the name of the subsystem
- if the subsystem is required for system operation (r), is selected as a default subsystem by the manufacturer (d), and/or must be installed when the system is running the miniroot (b)

Note: Most software that is required for system operation must be installed from the miniroot, as well as some optional products. The steps in “Installing a New Version of the Operating System Software” on page 110 detail a miniroot installation.

- how much additional disk space (in blocks, where 1 KB = 2 blocks) the subsystem will occupy (a positive number such as +100 shows that it will take an additional 50 KB, while a negative number such as -60 shows that the new version of the subsystem is smaller than the old version and will free 30 KB)
- a brief description of the subsystem

At the end of the listing, *Inst* shows whether you have enough disk space to install all the subsystems that are selected for installation, including temporary overhead needed for the installation process. For more information on the products and subsystems, see the product’s release notes.

You can change which subsystems are selected for installation in these ways:

- To select a subsystem for installation, type:

```
install subsystem
```

For example, when a new version of a product is available and you have an older version installed, *list* shows you this information:

```
U dmedia_tools.sw.soundtools
U dmedia_tools.sw.movietools
U dmedia_tools.data.prosonus
```

To select one subsystem for installation, type:

```
install dmedia_tools.sw.soundtools
```

To select all subsystems of the product for installation, type:

```
install dmedia_tools
```

list then shows this information:

```
i U dmedia_tools.sw.soundtools
i U dmedia_tools.sw.movietools
i D U dmedia_tools.data.prosonus
```

- To prevent a new subsystem or a different version of an existing subsystem from being installed, type:

keep *subsystem*

For example, when a large, new subsystem that you do not want to install is selected for installation, *list* shows this information:

```
i N dmedia_tools.data.prosonus
```

To prevent *Inst* from installing it, type:

keep **dmedia_tools.data.prosonus**

list then shows this information:

```
N dmedia_tools.data.prosonus
```

- To remove a subsystem that is currently installed, and to prevent a new version from being installed in its place, type:

remove *<subsystem>*

For example, when a subsystem is already installed and a newer version is available, *list* shows this information:

```
i U dmedia_tools.data.prosonus
```

To remove the current version and prevent *Inst* from installing the new version, type:

remove **dmedia_tools.data.prosonus**

list then shows this information:

```
U dmedia_tools.data.prosonus
```

When you have made your choices, start the installation. At the `Inst>` prompt, type:

go

Troubleshooting Software Installation

This section covers the three most common problems that may arise during software installation. See the section that describes the problem you have encountered.

- “System Cannot Find the New Software” on page 119
- “System Cannot Complete an Installation” on page 120
- “System Reports Errors After an Installation” on page 121

For comprehensive troubleshooting information, see the online *Software Installation Administrator's Guide*.

System Cannot Find the New Software

The system cannot find the software when:

- There is no CD in a drive that you specified.
- The remote CD drive that you specified is not enabled for remote software installation. Contact the administrator of the system to which the drive is connected, and make sure remote installations are allowed from that CD drive. For more information, select “Online Books” from the Help toolchest and search for “Allowing Remote Users to Install Software From Your CD Drive” in the online *Personal System Administration Guide*.
- Your system cannot contact the system on the network that has the software. Select “Online Books” from the Help toolchest and search for “Troubleshooting General Network Errors” in the online *Personal System Administration Guide*.
- You entered an incorrect directory name.

This typically happens when you are installing from a remote CD drive, and the drive is not accessible from (is not mounted at) the */CDROM* directory. Choose “Disk Drives” from the Find toolchest to find the drive, insert the CD into the drive, then double-click it to see the directory from which you can access it.

Also, be sure to complete the full pathname with *dist*, which is the name of the directory on the CD in which the software is stored. For example, the full pathname for new software on a CD whose pathname is */drives/cdrom* on a system named *mars* typically is *mars:/drives/cdrom/dist*

System Cannot Complete an Installation

Typically the system cannot complete an installation when:

- There is not enough disk space to install all the products you selected for installation. In this case, you could:
 - Select fewer subsystems to install (see “Choosing Subsystems to Install or Remove” on page 115).
 - Remove subsystems that are already installed (see “Choosing Subsystems to Install or Remove” on page 115).
 - If your system is up and running (that is, if it is not doing a miniroot installation such as installing new system software), quit *Inst* and remove or archive files or directories. For more information, select “Online Books” from the Help toolchest, and see “Freeing Up Disk Space” in the online *Personal System Administration Guide*.
- You need to install companion or prerequisite subsystems, or you have chosen to remove subsystems that are prerequisites for subsystems that are already installed or are selected for installation. In this case, you may see this error message:

```
ERROR: Conflicts must be resolved.
```

After this message, *Inst* lists each subsystem that is causing a conflict, and presents options for resolving the conflict. Read the description of each conflict and its resolution options, then choose an option using these guidelines:

- When you have selected an optional product that is incompatible with the rest of the operating system, do not install it.
- When you have selected incompatible products, choose to install the newer version of a product.
- When the system is missing a prerequisite product or subsystem, choose to install the prerequisite.

Each option is numbered; for example, option 1 for the first conflict is numbered 1a; option 2 for the same conflict is 1b. You can choose only one option per conflict. (For more information, or if your system is not running the IRIX 5.3 release, type: `help conflicts`.) To choose option 1a, at the `Inst>` prompt type:

```
conflicts 1a
```

If you have several conflicts, you can enter your choices all at once. For example, to choose 1a, 2b, and 3b, type:

```
conflicts 1a 2b 3b
```

When all conflicts are resolved, you see this message:

```
No conflicts
```

To resume the installation, type:

```
go
```

System Reports Errors After an Installation

If the system reports errors after an installation is complete, read the error message carefully, and follow its instructions. The message suggests that you type `help <topic>` for online instructions.

Warning: If the errors occur after you install new system software, do not turn off the system or press the Reset button. This could result in a system that cannot restart.

If you cannot solve the problem using the online help, contact your local support organization.

Troubleshooting

This chapter describes how to diagnose hardware problems on your Indigo² workstation. It also explains how to run diagnostic tests.

Troubleshooting

This chapter tells you how to:

- use system tests to diagnose hardware problems
- recover from a system crash
- disable the workstation password

To order and replace parts, see Chapter 8, “Ordering, Removing, and Installing Replacement Parts.”

Diagnosing Hardware Problems

There are four ways to diagnose hardware problems:

- **Power-on tests**—tests your major hardware parts as the system is booting up. If a part is faulty, the system notifies you with the LED and error messages.
- **Diagnostic tests**—more comprehensive tests of your system’s hardware. The system informs you if it finds a faulty part.
- **Confidence tests**—used if you think you have a problem with your keyboard, mouse, monitor, or a peripheral. The confidence tests verify which parts are working correctly.

Power-on Tests

Table 7-1 briefly lists symptoms and probable causes during power-on diagnostics.

Table 7-1 Troubleshooting Symptoms and Probable Causes

Symptom	System State	Cause
No LED	No power to unit	Power supply failure—check rear of unit for fan operation. Check system disk (green LED should flash during power-on). Possible CPU failure. Backplane not seated.
Solid amber LED		CPU board or graphics board failure.
Flashing amber LED	No memory found	SIMM failure. Check error messages for faulty SIMM.
No boot tune	No audio	Faulty speaker. Faulty CPU board. Volume set too low or zero.
Solid green LED	System menu displayed on booting up	Diagnostics successful.
No LED on system disk at any time	No system boot	Drive not all the way into slot—check drive. Drive failure—see your site administrator.
Diagnostic error messages, no login icons	Diagnostic failure No graphics	CPU failure. Graphics board failure. Monitor failure.

When you turn on the power switch, your system should go through these steps:

- The LED on the front of the machine blinks green, then turns amber, and then the system initiates power-on diagnostics.
- The system runs power-on diagnostics for about five seconds; then the disks spin up. This takes about 15 seconds for each hard disk.
- When the system passes all power-on tests, the LED turns green.
- The system boots IRIX or brings up a menu, if you configured your system to do so.

If the LED comes on, but there is no image on your monitor, try connecting an ASCII terminal (at 9600 baud) to serial port 1 on the back of your system. On the ASCII terminal you may see error messages that will help you diagnose the problem.

If your system does not operate as described above, you may have a problem. Below is a list of possible symptoms, error messages, and cures to fix your system or locate the faulty part.

No Visible Light from the LED with No Error Message

During power-on, if the system LED doesn't light up and no error message appears on the screen, follow these steps:

1. Disconnect the power cable from the back of the system.
2. Remove the top cover from the system and make sure the EISA backplane is firmly seated by pressing down on top of it.

The backplane is the gold-colored metal wall that extends from the fan in the front of the system, along the back of the expansion board slots, to the back of the chassis. It's okay to press quite firmly on the top of the backplane wall.

3. Check to make sure the internal power connectors are attached correctly to the system board.
4. Replace the top cover and reattach the power cable to the back of the system.
5. Check all cables.

Make sure the cables are securely connected and the power cable is plugged into an outlet that works.

6. Adjust the brightness control knob on the monitor to test for adequate light on the screen.

7. Make sure you've pressed the power switch to turn on the system.

If all of the cables are connected and the symptoms remain, you may have a faulty power supply.

To see if you have a faulty power supply, follow these steps:

1. Check to see if the fans are running. Feel if there is airflow from the vents and listen for the sound of the fans running.

One fan is in the front of the system on the left. The other fan is in the back of the system inside the power supply.

If the fans are not running, the power supply is faulty or overloaded. Early power supplies may not be adequate for newer configurations.

2. Go to "Replacing the Power Supply" on page 176 to remove the power supply.
3. Follow the instructions in "Ordering Replacement Parts" on page 156 to order a new power supply.
4. Contact your service provider for further instructions.

A Blinking Amber LED with No Error Message

If the LED keeps blinking and no error message appears on the screen, one or more memory SIMMs may be faulty. Go to "Replacing Internal Parts" on page 157 to check that all SIMMs are seated all the way into the sockets. Then power on the system again.
service

If the LED still blinks and the screen is blank, replace all four SIMMs. Follow the instructions in "Ordering Replacement Parts" on page 156 to order new SIMMS and "Replacing Internal Parts" on page 157 to remove the faulty SIMMs. Then contact your service provider for further instructions.

A Blinking Amber LED with an Error Message

If the LED stays blinking and a message appears on the screen, one or more pieces of hardware may be faulty. Below is a list of messages and where to go from there:

1. If you see this message:

No usable memory found. Make sure you have a full bank (4 SIMMs)

- Go to “Replacing Internal Parts” on page 157 to check that all of your SIMMs are seated all the way into the sockets.
 - Power the system on again.
If you get the same message, the SIMMs are faulty.
 - Remove the faulty SIMMs.
 - Go to “Ordering Replacement Parts” on page 156 to order replacement SIMMs.
 - Contact your service provider for further instructions.
2. If you see this message:
Check or replace: SIMM#
- Follow the instructions in “Replacing Internal Parts” on page 157 to make sure the indicated SIMM is seated all the way into its socket.
represents the SIMM number that failed the test (for example, SIMM 1, SIMM 2).
 - Power on the system again. If you get the same message, the SIMM is faulty.
 - Remove the faulty SIMM.
 - Go to “Ordering Replacement Parts” on page 156 to order a replacement SIMM.
 - Contact your service provider for further instructions.
3. If you see this message:
Memory is not usable. Check or replace all SIMMs.
- Follow the instructions in “Replacing Internal Parts” on page 157 to check that all of your SIMMs are seated all the way into the sockets and that they are installed in the correct slots.
 - Power on the system again.
If you get the error message, then all SIMMs are faulty.
 - Remove the faulty SIMMs.
 - Follow the instructions in “Ordering Replacement Parts” on page 156 to order new SIMMs.
 - Contact your service provider for further instructions.

A Solid Amber LED with No Error Message

If the amber LED stays on without blinking or turning green, the memory is working but some other part is faulty.

1. If you hear a dissonant piano chord sound from the speaker, the graphics board has failed the test. Check to make sure the graphics board is installed properly.
 - Follow the instructions in “Replacing Internal Parts” on page 157 to remove the graphics board and then reinstall it.
 - Power on the system.
If no message is displayed on the monitor, the graphics board is faulty.
 - Remove the board.
 - Follow the instructions in “Ordering Replacement Parts” on page 156 to order a replacement board.
 - Contact your service provider for further instructions.
2. If you do not hear a dissonant piano chord sound from the speaker:
 - Make sure the monitor is plugged in and turned on and the brightness control knob on the monitor is turned to provide adequate light to the screen.
 - Check to make sure that the system disk is seated all the way in its slot.
 - Try powering on again.
If an error message is still not displayed, the graphics board is faulty.
 - Remove the board.
 - Follow the instructions in “Ordering Replacement Parts” on page 156 to order a replacement board.
 - Contact your service provider for further instructions.

A Solid Amber LED with an Error Message

If the LED stays amber and a message appears on the screen, one of your parts is faulty.

1. If you see this message:
Check or replace: Graphics board.
The graphics board has failed. First, make sure the board is seated properly.

- Follow the instructions in “Replacing Internal Parts” on page 157 to remove the graphics board and reinstall it.
 - Power on the system.
If you get the same error message, the graphics board is faulty.
 - Remove the board.
 - Follow the instructions in “Ordering Replacement Parts” on page 156 to order a replacement board.
 - Contact your service provider for further instructions.
2. If you see this message:
Check or replace: CPU module
The CPU module has failed. First, make sure the module is seated properly.
- Follow the instructions in “Replacing Internal Parts” on page 157 to remove the CPU module and reinstall it.
 - Power on the system.
If you get the same error message, you have a faulty CPU module.
 - Remove the module.
 - Follow the instructions in “Ordering Replacement Parts” on page 156 to order a replacement module.
 - Contact your service provider for further instructions.
3. If you see this message:
Check or replace: CPU baseboard
The CPU baseboard has failed.
- Follow the instructions in “Replacing Internal Parts” on page 157 to remove the CPU baseboard and reinstall it.
 - Power on the system.
If you get the same error message, you have a faulty CPU baseboard.
 - Remove the board.service
 - Follow the instructions in “Ordering Replacement Parts” on page 156 to order a replacement board.
 - Contact your service provider for further instructions.

4. If the screen looks unusual:

- Make sure all of the cables are firmly connected and that the brightness control knob on the monitor is turned to provide adequate light to the screen.

If the screen has lines through it, measles, or looks unusual, the graphics board is faulty.

- Remove the board.
- Follow the instructions in “Ordering Replacement Parts” on page 156 to order a replacement board.
- Contact your service provider for further instructions.

Green LED but the Keyboard Doesn't Work

If the keys on the keyboard don't work, the keyboard is failing.

1. Shut down your system and make sure that the keyboard cable is firmly connected to the keyboard (not the mouse) connector.
2. Power on the system again.

If the keyboard still doesn't work, the keyboard is faulty.

3. Remove the keyboard.
4. Follow the instructions in "Ordering Replacement Parts" on page 156 to order a replacement keyboard.
5. Contact your service provider for further instructions.

Green LED but the Mouse Doesn't Work

If the mouse doesn't work, the mouse is failing.

1. Shut down your system and make sure the cable is firmly connected to the mouse (not the keyboard) connector.
2. Power on the system again.

If the mouse still doesn't work, you have a faulty mouse.

3. Follow the instructions in "Ordering Replacement Parts" on page 156 to order a replacement part.
4. Contact your service provider for further instructions.

Interactive Diagnostic Environment (IDE) Tests

When you power on the system, power-on tests check the system's essential hardware components. Diagnostic tests give you a greater depth of testing capabilities. Diagnostic tests take about 30 minutes to run. (It takes 15-30 minutes longer for each additional hard disk.)

You can stop the tests at any time by pressing the <Esc> key.

The system stops the testing if it finds any errors and reports any failures on the screen. To run the diagnostic tests, follow these steps:

1. Shut down the system.
 - Place the cursor over the word “System” in the Toolchest in the upper left corner of your screen.
 - Click the left or right mouse button so that you see the menu.
 - Place the cursor over the words “System Shutdown” and click the mouse button.

After a few seconds you see the notifier shown in Figure 7-1.

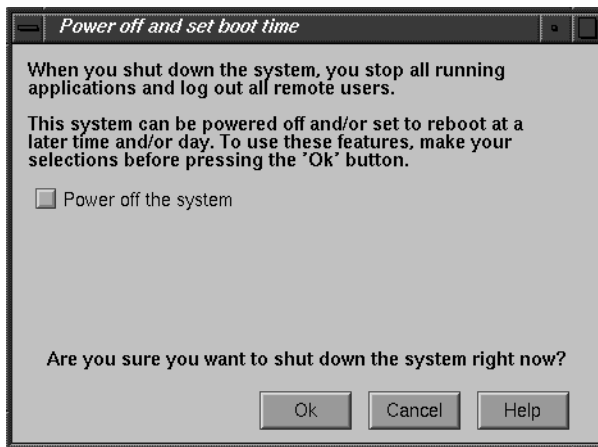

Figure 7-1 System Shutdown Caution Notifier

2. Click *OK*. The screen clears and you see the notifier shown in Figure 7-2.

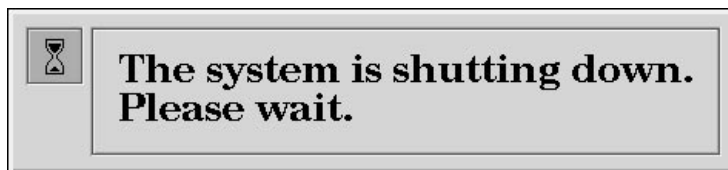

Figure 7-2 System Shutdown Notifier

3. After a few seconds, the screen clears and when you see the notifier shown in Figure 7-3, click on the *Restart* button.

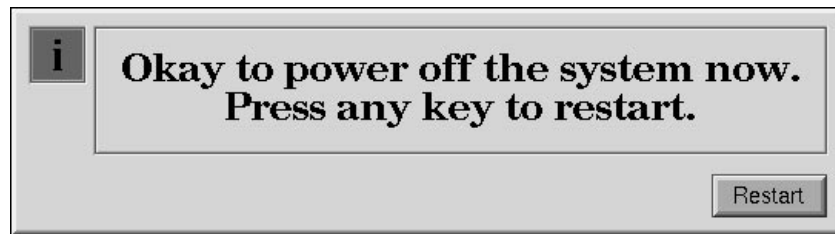

Figure 7-3 Okay to Power Off Notifier

Note: If the system is malfunctioning and you cannot communicate with it using the mouse, keyboard, or over the network, then press the **Reset** button located behind the front door on the front of the Indigo² chassis, as shown in Figure 7-4.

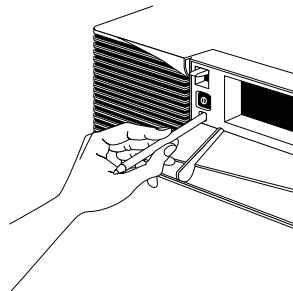

Figure 7-4 Pressing the Reset Button

4. When you see the notifier shown in Figure 7-5, click *Stop for Maintenance*, or press **<Esc>**.

If you cannot reach this menu, your system is faulty. Contact your service organization.

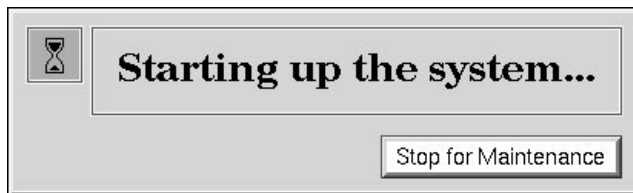

Figure 7-5 Starting up the System Notifier

The System Maintenance menu appears.

5. Start diagnostics by clicking the *Diagnostics* icon or by typing:

3

6. You see a message similar to this:

```
SGI Version 5.3 IP22 IDE field
October 22 1994
+
```

Note: If you do not see this message, you cannot run the diagnostics. You may have a faulty disk. Contact your service organization.

The character on the last line (next to the cursor) shows a spinning combination of slashes and dashes while the tests are running. Also, the LED on the front of the main unit blinks slowly throughout the testing process.

Included in the diagnostics is a series of graphics tests. During these tests, the screen goes blank and displays various images.

7. Watch for messages.

If the system's hardware is completely healthy, after 10 to 30 minutes (could be more if you have more than one hard disk) you'll see this message:

```
Diagnostic tests completed with no failures detected.
Press <Enter> to continue.
```

- Press **<Enter>** to return to the System Maintenance menu, where you can restart the system by selecting 1. If problems persist, or if you still cannot restart the system, you may have a software problem. See "Recovering from a System Crash" on page 145.

If the diagnostics find a problem, you see a message like this:

```
ERROR: Failure detected on the CPU module
```

or a message indicating a failure with the CPU baseboard, audio board, or graphics board.

- This means the part indicated has failed. Record this information.

You may also see other messages that report faulty peripherals or subsystems. If an error message is displayed, follow the instructions in “Ordering Replacement Parts” on page 156 to order a replacement part. Then follow the instructions to remove the faulty part and contact your service provider for further instructions.

Confidence Tests

If your keyboard, mouse, monitor, audio subsystem, or one of the SCSI peripherals (excluding hard disks) isn't working properly, use the confidence tests to verify that each device is working. Your system must be booted and running the IRIX operating system to run these tests.

To run the confidence tests, choose “Run Confidence Tests” from the System toolchest. You see the Confidence Tests form shown in Figure 7-6, with icons for each device for which a confidence test exists. Instructions on how to run each test are contained in the sections below.



Figure 7-6 Confidence Tests Form

If you run the confidence tests and you find that one of the devices is faulty, follow the instructions in “Ordering Replacement Parts” on page 156 to order a replacement part. Then contact your service provider for further instructions.

Audio

If you are running an audio application and you do not hear the audio output, first make sure all cables are connected properly. Then use the confidence test to make sure the audio is functioning properly.

To test audio, follow these steps:

1. From the System toolchest, choose “Run Confidence Tests.” You see the Confidence Tests form, as shown in Figure 7-6.
2. Select the Audio icon and click *Open* or double-click the icon.

3. Click on the *Start Test* button.

You see the form shown in Figure 7-7. The Audio Control Panel is also displayed.

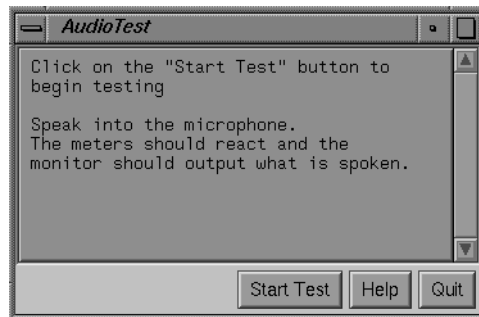

Figure 7-7 Audio Confidence Test Form

4. Follow the instructions on the form.
5. If your audio is still not responding, you may have a bad audio system. If this is the case, you must replace the CPU board. Follow the instructions in "Ordering Replacement Parts" on page 156 to order a replacement part.
6. Contact your service provider for further instructions.

Dial and Button, Tablet, Genlock, and Spaceball

You'll find instructions on how to run the confidence test for the dial and button box, digitizer tablet, Spaceball, and Genlock options in the installation booklet that comes with each option.

CD-ROM Drive

Before you run a confidence test on a CD-ROM drive, make sure it is correctly installed in your system. "Installing External SCSI Devices" on page 90 tells you how to install a CD-ROM drive. If you suspect that there is a problem with the drive, remove it and then reinstall it. If you still have problems, run the CD-ROM drive confidence test.

To run a CD-ROM drive confidence test, follow these steps:

1. From the System toolchest, choose “Run Confidence Tests.” You see the Confidence Tests form, as shown in Figure 7-6.
2. Select the CD-ROM icon and click *Open* or double-click the icon.
You see the CD-ROM drive confidence test form.
3. Start the CD-ROM drive test.
 - When you test the CD-ROM drive, load a CD into the drive.
 - Double-click the CD-ROM icon to start the test. You see CD-ROM drive test in progress.When the test is complete, you see the CD-ROM drive test completion notifier.
4. Click *Continue* to dismiss the notifier.

If the drive doesn't pass the test, follow the instructions in “Ordering Replacement Parts” on page 156 to order a replacement part. Then contact your service provider for further instructions.

Floppy Drive

Before you run a confidence test on a floppy drive, make sure it is correctly installed in your system. “Installing an Internal Drive” on page 83 tells you how to install a floppy drive. If you suspect that there is a problem with the floppy drive, first remove it and then reinstall it. If you still have problems, run the floppy drive confidence test.

To run a floppy drive confidence test, follow these steps:

1. From the System toolchest, choose “Run Confidence Tests.” You see the Confidence Tests form, shown in Figure 7-6.
2. Select the Floppy icon and click *Open* or double-click the icon.
3. Select the icon that represents your floppy drive and click *Open* or double-click the icon.
4. Select the density of the floppy you are using.

Caution: When you test the floppy drive, use a floppy that is blank or doesn't have information that you need to keep. The floppy drive destroys any information on the floppy in the process of testing the hardware.

5. Insert the floppy into the floppy drive and click “*Test.*”

When the test is complete, you see the floppy drive test completion notifier.

6. Click *Continue* to dismiss the notifier.

If the drive doesn't pass the test, follow the instructions in “Ordering Replacement Parts” on page 156 to order a replacement part. Then contact your service provider for further instructions.

Keyboard

The keyboard confidence test is useful if the keyboard is not responding to input. Before you run the confidence test on the keyboard, make sure that the cable that connects the keyboard to the system is firmly connected. Once you're sure the connection is good, use the confidence test to make sure that the keyboard is working correctly.

To test the keyboard, follow these steps:

1. From the System toolchest, choose "Run Confidence Tests." You see the Confidence Tests form, as shown in Figure 7-6.
2. Select the Keyboard icon and click *Open* or double-click the icon.

You see the form shown in Figure 7-8.

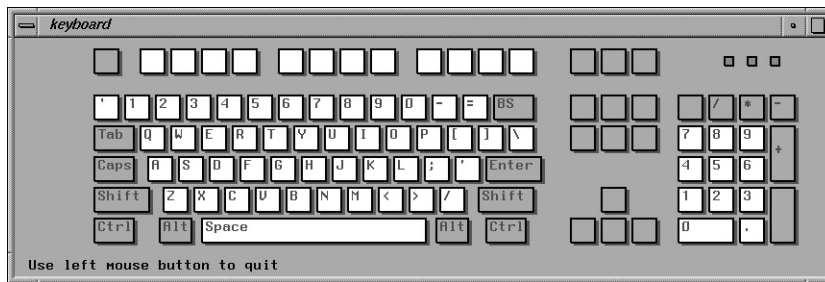

Figure 7-8 Keyboard Test

3. To use the test, press the different keys on the keyboard. The picture on the screen should highlight the key that you press.

If the graphic doesn't reflect the key that you press, you may have a problem with the keyboard or with the cable that connects the keyboard to the system.

If you're using a keyboard other than the one supplied by Silicon Graphics, the key layout may be different.

4. Close the keyboard test by clicking the button in the upper left-hand corner of the keyboard graphic and selecting "Quit." The screen goes back to the way it was before you launched the confidence test.

If your keyboard does not work, follow the instructions in "Ordering Replacement Parts" on page 156 to order a replacement part. Then contact your service provider for further instructions.

Monitor

If the monitor isn't working properly or the display is distorted, first check the cable that connects the monitor to the system. Also check to make sure that the brightness knob is providing sufficient light to the screen, that the monitor video cable is firmly connected to both the monitor and the Indigo² chassis, and that the thumbscrews are screwed in all the way.

If you still have problems, use the confidence test to check that the monitor is working properly. Follow these steps to test the monitor:

1. From the System toolchest, choose "Run Confidence Tests." You see the Confidence Tests form, as shown in Figure 7-6.
2. Select the monitor icon and click *Open*, or double-click the icon.
The monitor test takes over the entire screen.
3. To run one of the tests from the menu, click the mouse over the menu choice and see how the monitor responds.
4. Click *Quit* when you are finished.

When you click *Quit*, the screen goes back to the way it was before you launched the confidence test.

If the monitor tests indicate a failure, follow the instructions in "Ordering Replacement Parts" on page 156 to order a replacement part. Then contact your service provider for further instructions.

Mouse

If the buttons on your mouse do not work, make sure that the mouse cable is firmly connected to the back of the system. If the buttons still don't work, you have a faulty mouse. Follow the instructions in "Ordering Replacement Parts" on page 156 to order a replacement mouse. Then contact your service provider for further instructions.

If the mouse is behaving strangely or only one of the mouse buttons works, make sure that the mouse cable is firmly connected to the system. If the buttons still don't work, try running the mouse confidence test.

Follow these steps:

1. From the System toolchest, choose "Run Confidence Tests." You see the Confidence Tests form, as shown in Figure 7-6.
2. Select the mouse icon and click *Open*, or double-click the icon. When you start the mouse test, you see only a mouse on the screen.
3. Test the mouse by moving it around and pressing each button.

As you press each of the mouse buttons and move the mouse around, the movement is reflected on the screen.

4. If the screen doesn't respond as you move the mouse or press the mouse buttons, the mouse may be faulty. If the mouse does not respond correctly, follow the instructions in "Ordering Replacement Parts" on page 156 to order a replacement mouse.
5. Press the <Esc> to quit the mouse test.

The screen goes back to the way it was when you launched the confidence test. Contact your service provider for further instructions.

Quarter Inch Tape and Digital Audio Tape Drives

Before you run a confidence test on a tape drive, make sure it is correctly installed on your system. If you suspect that there is a problem with the tape drive, first remove it and install it again. If you still have problems, run the appropriate tape drive confidence test.

To run a tape drive confidence test, follow these steps:

1. From the System toolchest, choose “Run Confidence Tests.” You see the Confidence Tests form, as shown in Figure 7-6.
2. Select the tape icon and click *Open* or double-click on the icon.
3. Click on the icon for the tape drive you have.
4. Insert a blank tape, or one that has information you don’t need, into the drive.
Caution: The tape drive destroys any information on the tape in the process of testing the hardware.
5. Start the tape drive test by double-clicking the tape icon to start the test.
When the test is complete, you see the tape drive test completion notifier.
6. Click *Continue* to dismiss the notifier.

If the drive doesn’t pass the test, follow the instructions in “Ordering Replacement Parts” on page 156 to order a replacement drive. Then contact your service provider for further instructions.

Recovering from a System Crash

If your system crashes because of a software malfunction, you first need to find a CD with the IRIX operating system release that matches the IRIX release you are running on your system. Then you can recover your data from your most recent full backup tape. The backup tape must be one that has been made using the System Manager backup tool, or with the `/usr/sbin/Backup` script. You can restore other types of backups, but must do so manually from a shell prompt. (Type `sh` at any question prompt to get a shell prompt.)

To recover from a system crash, follow these steps:

1. If the system is malfunctioning and you cannot communicate with it using the mouse, or keyboard, or over the network, press the **Reset** button located behind the front door, as shown in Figure 7-9.

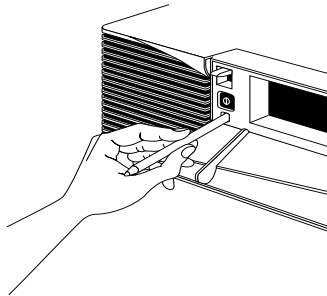

Figure 7-9 Pressing the Reset Button

2. When the system startup notifier appears, as shown in Figure 7-10, click *Stop for Maintenance* or press <ESC> to bring up the System Maintenance menu.

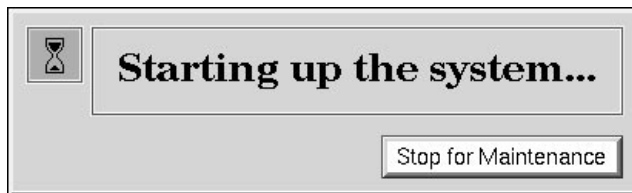

Figure 7-10 System Startup Notifier

3. Click the Recover System icon in the System Maintenance menu, or type:
4

Note: If you are using an ASCII terminal, type 4 at the System Maintenance menu. The System Recovery menu appears, as shown in Figure 7-11.



Figure 7-11 System Recovery Menu

4. Click the appropriate drive icon from which you want to recover the software.

For example, if you have a CD-ROM drive connected to your system, click the *Local CD-ROM* icon. Then click *Accept* to start.

You then see the notifier shown in Figure 7-12, prompting you to insert the media into the drive.

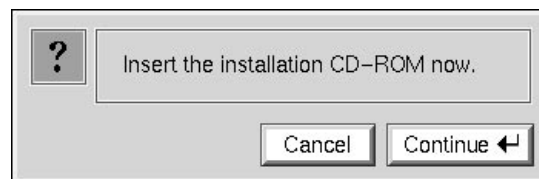

Figure 7-12 Media Request Notifier

If you don't have a CD-ROM drive, you can use a drive that is connected to another system on the network. At the System Recovery menu, click the *Remote Directory* icon. When a notifier appears asking you for the remote hostname, type the system's name, a colon (:), and the full pathname of the CD-ROM drive, followed by */dist*. For example, to access a CD-ROM drive on the system *mars*, you would type:

```
mars:/CDROM/dist
```

5. Insert the IRIX CD that came with your system, then click *Continue*.

The CD-ROM drive begins reading information from the CD. The system takes approximately 5 minutes to copy the information from the CD that it needs.

6. After everything is copied from the CD to the system disk, you can restore your data from a recent full backup tape. The backup must be one that has been made using the System Manager backup tool, or with the `/usr/sbin/Backup` script.

Note: If you need to check something on your system or do anything special, you can get a shell prompt by typing `sh` at most question prompts.

You see the following messages.

```
*****
SYSTEM RECOVERY
*****
```

7. If you have a local tape device, you see this message:

```
Restore will be from <tapename> OK? ([Y]es, [N]o): [Y]
<tapename> is the name of the local tape device.
```

8. If you have a remote (network) tape device, when no tape device is found, or when you answered “No” to the question in the previous bullet, you see this message:

```
Remote or local restore ([r]emote, [l]ocal):
```

- If you answer “remote,” you have chosen to restore from the network, and you are then asked to enter the following information:

- the hostname of the remote system
- the name of the tape device on the remote system
- the IP address of the remote system
- the IP address of your system

The IP address must consist of two to four numbers, separated by periods, such as 192.0.2.1

- If you answer “local,” you have chosen a tape device that is connected to your system, and you are then asked to enter the name of the tape device.

9. When you see the following message, remove the CD-ROM, insert your most recent full backup tape, then press `<Enter>`.

```
Insert the first backup tape in the drive, then press <Enter>,
[q]uit (from recovery), [r]estart:
```

10. There is a pause while the program retrieves several files from the tape describing the system state at the time the backup was made. Then you see this message:

```
Erase /x filesystem and make new one (y,n)? [n]
```

where *x* is the file system. It prompts you for every file system that was known at the time of the backup.

Answer by typing either *y* or *n*.

- If you answer no to this question, the system tries to salvage as many files as possible, then it uses your backup tape to replace the files it could not salvage. Usually you should answer *n* for no, especially if your backup tape is not very recent. If the file systems were badly damaged, or the backup was from a different level operating system, you may need to answer yes.
- If you answer *y* for yes, the system erases the file system and copies everything from your backup tape to the disk. The system loses any information on that filesystem that you created between now and when you made your backup tape.

11. You see this message:

```
Starting recovery from tape.
```

After two or three minutes, the names of the files that the system is copying to the disk start scrolling. When the recovery is complete, you see this message:

```
Recovery complete, restarting system.
```

Then the system restarts.

When you see the login screen, the system is ready to go.

Note: If your backup tapes were old, or you were changing your operating system level, you should reinstall the operating system from the IRIX CD that came with your system after system recovery is complete. When you see the “Starting up the system” notifier, press <Esc>, or click on *Stop for Maintenance*. Then click the *Install System Software* icon. For more information on installing the operating system, go to Chapter 6, “Installing Software.”

Disabling the System Maintenance Password

If you are in the System Maintenance menu, and you choose the Install System Software, Run Diagnostics, Recover System, or Enter Command Monitor icon, you may be prompted for a password, as shown in Figure 7-13.



Figure 7-13 Enter Password Prompt

If you do not know the password, you can disable it by removing a jumper from the inside of the workstation.

Note: If you are able to boot your system and are running IRIX, you can log in as root, and disable the password by typing `/etc/nvram passwd_key ""` at the shell prompt.

To remove the jumper and disable the password, follow these steps:

1. Shut down the system.
 - Press and release the power switch to shut down the software and power off the system.
 - Press and release the power switch on your monitor to turn off the monitor.
 - Disconnect the power cable from the back of the system.
2. Remove the cover.
3. Remove the 5-1/4" drive tray.

The jumper is located on the front and center edge of the CPU baseboard, as shown in Figure 7-14.

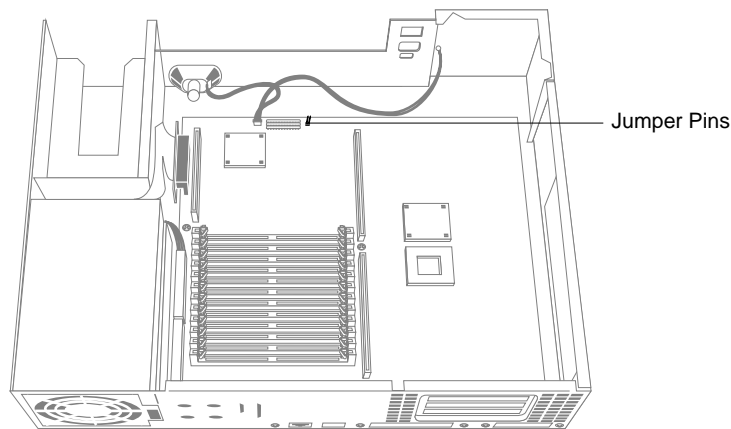

Figure 7-14 Locating the Password Jumper

4. Remove the jumper and save it. You must reinstall it if you choose to reset the password.
5. Replace the 5-1/4" drive tray.
6. Replace the cover.
7. Reconnect the power cable to the back of the system.

When you return to the System Maintenance menu and choose one of the four icons mentioned before, you see the notifier shown in Figure 7-15.

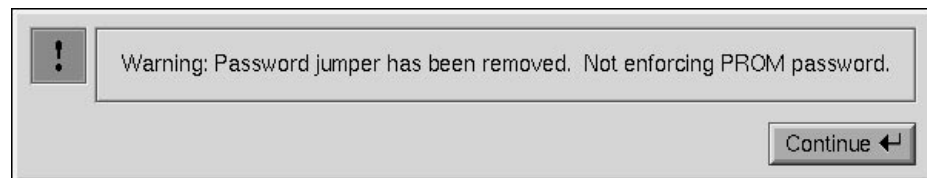

Figure 7-15 Disabled Password Notifier

If you want to reenable the password, you can do so by entering the command monitor and giving the command *resetpw* to clear the password. Then power the system down,

remove the top cover, and replace the jumper. Replace the top cover and power up the system.

Service and Support Information

When you purchased your system you may have purchased a support program from either Silicon Graphics, or a vendor who supplies software. Whenever you encounter any problems that you cannot solve using the methods in this chapter, contact the organization from which you purchased the support program.

If you would like support for your Silicon Graphics products, contact your service provider.

Ordering, Removing, and Installing Replacement Parts

This chapter describes how to remove and replace parts in your Indigo² workstation. It also explains how to return the part or the system to your service provider.

Ordering, Removing, and Installing Replacement Parts

This system is designed to be user maintainable. If diagnostic tests identify a faulty part, you must order a replacement part, remove the faulty part, and install a replacement part. Contact your service organization before removing the faulty part.

This chapter tells you how to replace the following parts:

- graphics board set
- CPU module
- power supply
- SIMM modules
- internal drives
- CPU baseboard
- keyboard or mouse
- external SCSI drives

Ordering Replacement Parts

If diagnostics have identified a faulty part, remove the faulty part, then follow these steps to order a replacement:

1. Copy the “Part Request Form” directly from the last page of this guide.
2. Note the name of the faulty part on the copy of the form.
3. Note the serial number of your system. The number is on a label on the back of the system.
4. Identify the part number of the faulty part.
5. Contact your service provider for further instructions.

Your service provider will ask you for the system serial number, configuration information, the faulty part’s part number, and a description of the problem.

6. Pack and ship the faulty part to your service provider if requested.

For maximum protection to the part, use two sturdy boxes for shipping. Graphics boards, CPU modules and SIMM modules are extremely sensitive to static electricity. Whenever possible, package them in antistatic bags.

- Place the faulty part and “Part Request Form” into one of the two boxes. Pack them in plenty of packing material so the part won’t sustain further damage. Tape the box securely.
- Place the box containing the faulty part into a larger box and fill the empty space with packing materials. Tape the box securely and affix a mailing label. Ship the box to your service provider.

Replacing Internal Parts

Internal replacement parts include the graphics board, CPU module, power supply, SIMM modules, internal drives, and CPU baseboard.

To replace an internal part, follow the steps below to shut down the system, remove the cover, attach the wrist strap, replace the part, replace the cover, and start up the system.

Shutting Down the System

To shut down the system, follow these steps:

1. Open the front cover.
2. Press and release the power switch on the front of the system to shut down the software and power off the system.

The system powers off automatically.

3. Press the monitor power switch to turn off your monitor.
4. Disconnect the power cable from back of the Indigo².

Removing the Cover

Once the system is shut down and all of the cables are disconnected, follow these steps:

1. Remove the front cover.
 - Face the front of the Indigo² chassis.
 - Open the front cover by snapping it away from the top edge of the chassis and tipping it down, as shown in Figure 8-1.

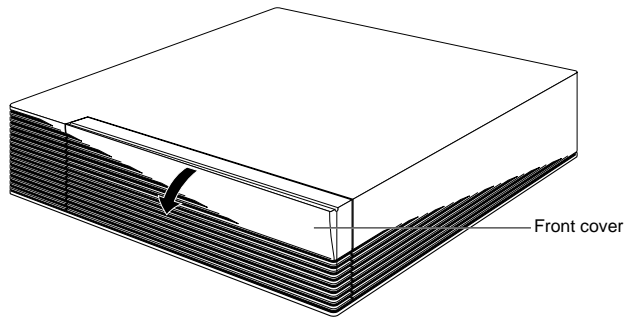

Figure 8-1 Removing the Front Cover From the Indigo² Chassis

2. Remove the front bezel.
 - Press down on the tabs on each side of the bezel, as shown in Figure 8-2.
 - Pull the bezel away from the chassis.

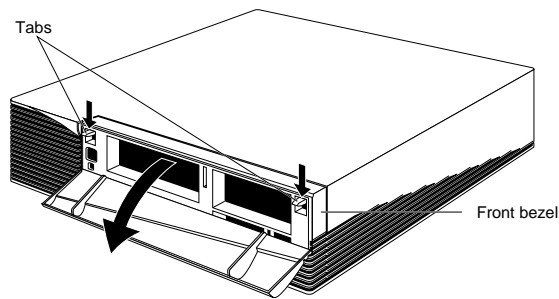

Figure 8-2 Removing the Front Bezel From the Indigo² Chassis

3. Remove the top cover.

- Press up on the tabs on each side of the drive openings.
- Pull up on the cover and rotate it back and away from the chassis, as shown in Figure 8-3.

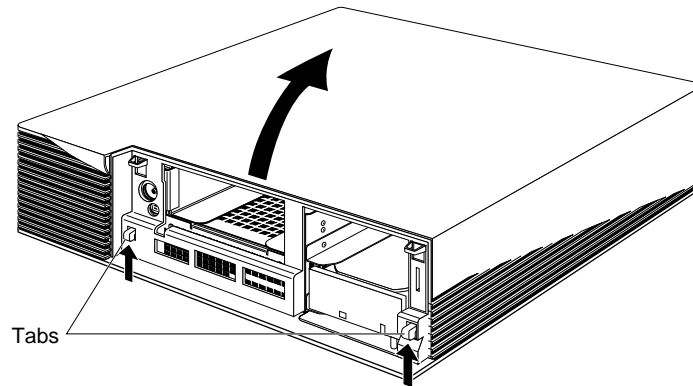

Figure 8-3 Removing the Top Cover From the Indigo² Chassis

Attaching the Wrist Strap

Wear the wrist strap to prevent the flow of static electricity, which can damage the board.

Caution: The components inside the Indigo² are extremely sensitive to static electricity; you must wear the wrist strap while replacing parts inside the system.

To attach the wrist strap, follow these steps:

1. Put the wrist strap over your wrist, making sure it is tight against your arm.
2. Attach the alligator clip to a metal part of the Indigo².

You are now ready to replace the part.

Replacing the Part

After you've shut down the system, removed the cover, and attached the wrist strap, turn to one of the following sections to replace the part you need to replace:

- “Replacing the Graphics Board Set” on page 160
- “Replacing the CPU Module” on page 169
- “Replacing the Power Supply” on page 176
- “Checking and Replacing Faulty SIMMs” on page 183
- “Replacing Internal Drives” on page 184
- “Replacing the CPU Baseboard” on page 185

Replacing the Graphics Board Set

To replace the graphics board set, follow these steps:

1. If you have not already shut down the system, removed the cover, and attached the wrist strap, go to “Replacing Internal Parts” on page 157 for instructions.
2. Move the system or position yourself so that you are facing the expansion slots.
The expansion slots are located on the left side of the system, behind the internal fan.
 - To replace an XZ or Extreme graphics board set, go to “Removing and Replacing the XZ or Extreme Graphics Board Set” on page 161.
 - To replace an XL graphics board, go to “Removing and Replacing the XL Board” on page 165.

Removing and Replacing the XZ or Extreme Graphics Board Set

To remove the XZ or Extreme graphics board set, follow these steps:

1. Make sure the wrist strap is attached to a metal part of the system.
2. Move the system or position yourself so that you are facing the expansion slots, as shown in Figure 8-4.
3. Open the metal panel in front of the expansion slots by pulling up on the panel and lowering it. Figure 8-4 shows an XZ graphics board set.

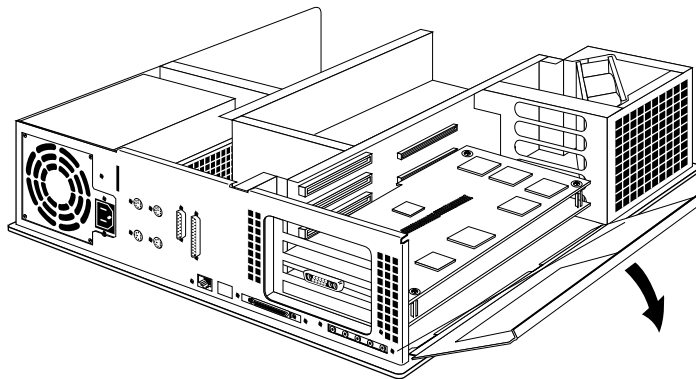

Figure 8-4 Lowering the Metal Panel in Front of the Expansion Slots

4. Remove the screws attaching the board to the system slots as shown in Figure 8-5.

The screws are located on the metal extension on the left side of each board.

Note: Figure 8-5 shows an XZ graphics board set. If your system has the Extreme graphics board set, there will be three screws to remove.

- Loosen each screw first with the Phillips screwdriver.
- Then unscrew it all the way with your hand, and remove it.

The screws are very small. If you drop a screw into the chassis, remove it to prevent the possibility of shorting the system.

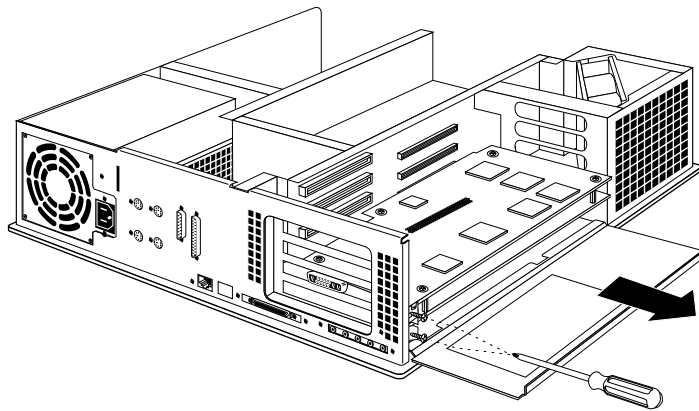

Figure 8-5 Removing the Screws From the Metal Extension

5. Pull the board set out of the system, as shown in Figure 8-6.
 - Turn both hands inward so that your thumbs point to the floor,
 - Place your index fingers behind the small metal posts on each side of the board.
 - Brace your thumbs against the chassis, and pull the board out of the slot. You may need to use some force.
 - Place the board set down on a flat, antistatic surface so the side with the chips faces up. An empty antistatic bag or a clean, dry desktop works well.

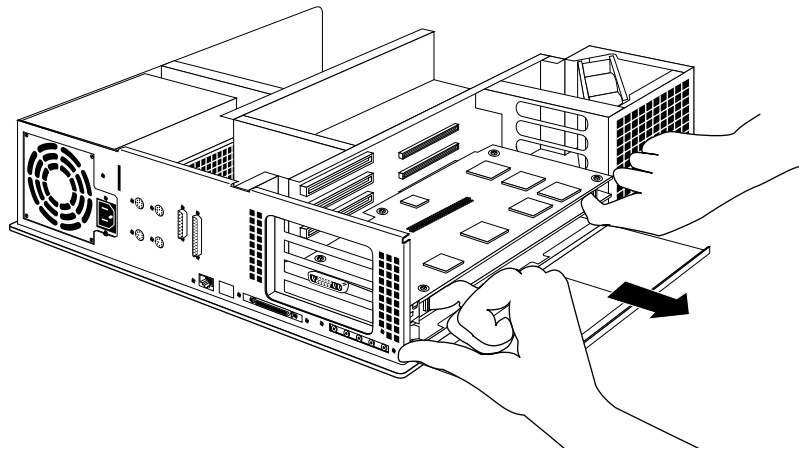

Figure 8-6 Pulling the Board Set out of the Chassis

6. Position the replacement board set in the lowest available slot, as shown in Figure 8-7.
 - Grasp the board set with metal extensions on the left and the sides with the chips facing up.
 - Align the metal extensions on the left of the board set with the slots on the chassis. At the same time align the right edge of the board set with the metal grooves on the right of the chassis, as shown in Figure 8-7.
 - Push the board set into the slot until the connector on the back of the board is securely connected to the connector on the EISA backplane.
7. Insert and tighten the screws that hold the board set to the chassis. The screw openings are located on the metal extension on the left side of each board. Make sure that the EMI lining is not damaged and remains between the chassis and the XZ graphics board's metal extension.

Note: Figure 8-7 shows an XZ graphics board set. If you have an Extreme graphics board set, there will be three screws to insert and tighten.
8. Tip the metal panel up in front of the boards you just installed until it snaps into place.

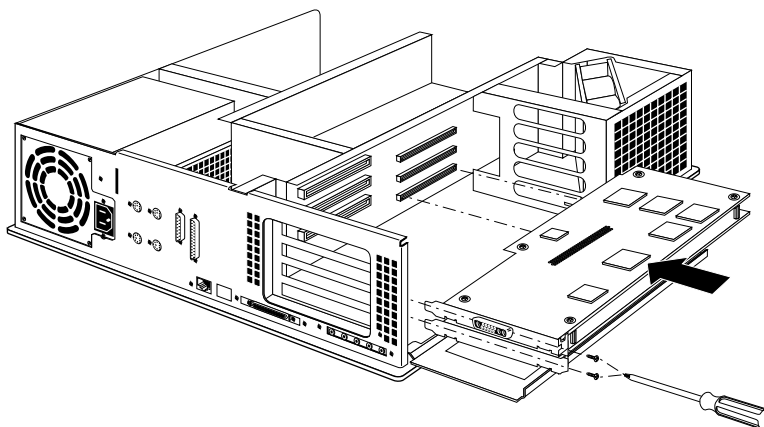

Figure 8-7 Replacing the Graphics Board Set

You are finished replacing the XZ or Extreme graphics board set. To replace the top cover, turn to “Replacing the Cover” on page 200.

Removing and Replacing the XL Board

To remove the XL graphics board, follow these steps:

1. Make sure the wrist strap is attached to a metal part of the system.
2. Move the system or position yourself so that you are facing the expansion slots.
3. Open the metal panel in front of the expansion slots by pulling up on the panel and lowering it, as shown in Figure 8-8.

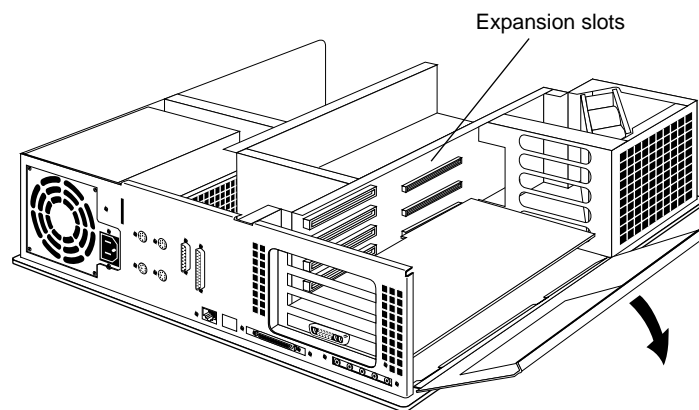

Figure 8-8 Opening the Metal Panel in Front of the Expansion Slots

4. Remove the screw attaching the graphics board to the system slot as shown in Figure 8-9.

The screw is located on the metal extension on the left side of the board.

- Loosen the screw first with the Phillips screwdriver.
- Then unscrew it all the way with your hand, and remove it.

Note: The screw is very small. If you drop it into the chassis, remove it to prevent the possibility of shorting the system.

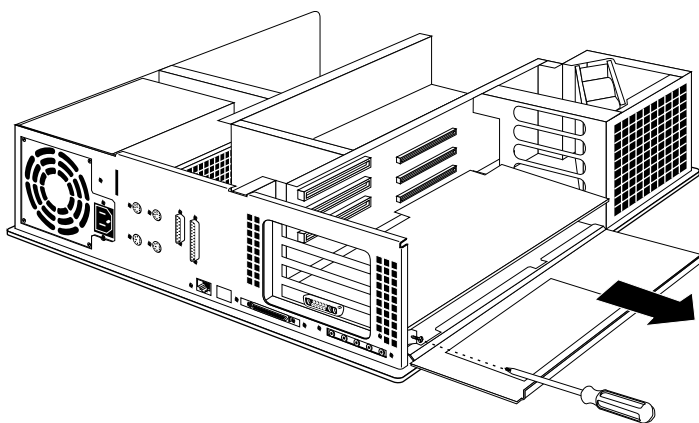

Figure 8-9 Removing the Screw From the Metal Extension

5. Remove the board from the chassis, using the two open-ended wrenches provided with the system. Note that if your XL board has handles attached, use them to extract the board instead of the wrenches.
 - Grasp the wrenches as shown in Figure 8-10. The orientation of the wrenches is important.

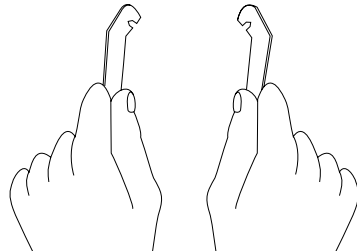

Figure 8-10 Orientation of the Wrenches

- Hook the ends of the wrenches in the small holes on each side of the front of the board, as shown in Figure 8-11.
- Brace your index fingers against the chassis and pry the wrenches outward. The board comes out.

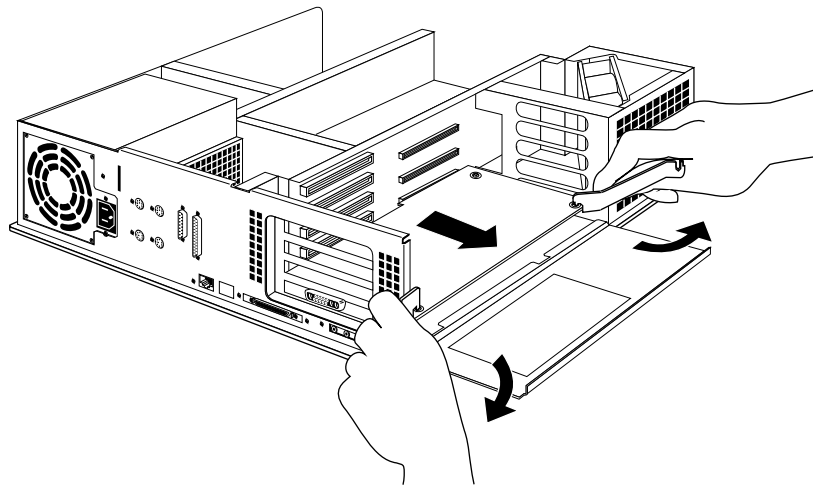

Figure 8-11 Removing the XL Board From the Chassis

- Place the board on a flat, antistatic surface so the side with the chips faces up. An empty antistatic bag or a clean, dry desktop works well.
6. Install the replacement board.
- Grasp the board with the metal extension on the left and the side with the chips facing up.
 - Align the metal extension on the left of the board with the slot on the chassis. At the same time align the right edge of the board with the metal grooves on the right of the chassis, as shown in Figure 8-12.

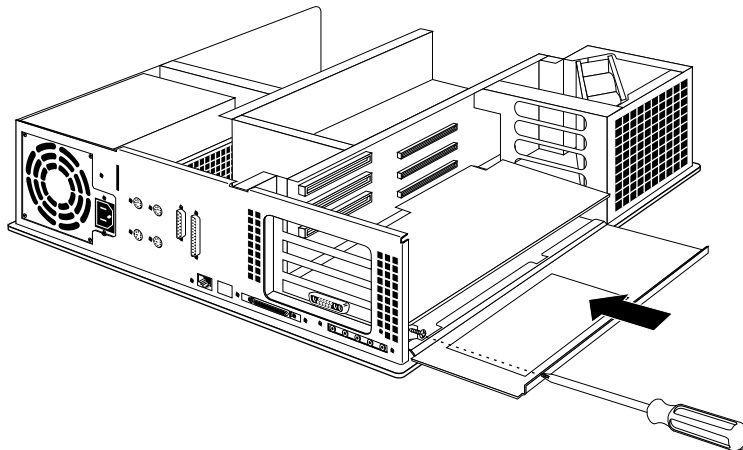

Figure 8-12 Replacing the XL Graphics Board in the Chassis

- Push the board into the slot until the connector on the back of the board is securely connected to the connector on the EISA backplane. Make sure that the EMI lining is not damaged and remains between the chassis and the XL graphics board's metal extension.
7. Insert and tighten the screw that holds the board to the chassis. The screw opening is located on the metal extension on the left side of the board. (See Figure 8-12).
8. Tip the metal panel up in front of the board you just installed until it snaps into place.

You are finished replacing the XL graphics board. To replace the top cover, turn to “Replacing the Cover” on page 200.

Replacing the CPU Module

To replace the CPU module, follow the steps below to remove the 5-1/4" drive tray, remove the CPU module, install the new CPU module, and install the drive tray.

1. If you have not already shut down the system, removed the cover, and attached the wrist strap, go to "Replacing Internal Parts" on page 157 for instructions.
2. Remove the 5-1/4" drive tray. If there is a drive installed, there is no need to remove the drive from the tray.
 - Disconnect the SCSI cable from the connector on the back of the 5-1/4" drive tray. (See Figure 8-13.)
 - Using a phillips screwdriver, loosen the two captive screws that hold the 5-1/4" drive tray to the chassis.

The screws are located below the drive tray in the center front of the system.

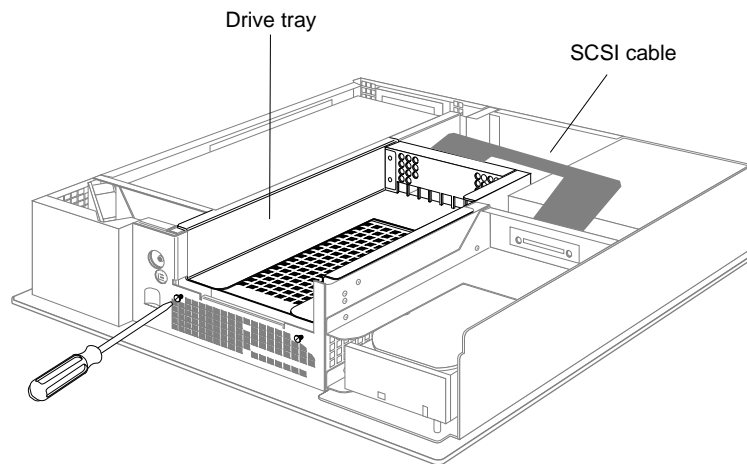

Figure 8-13 Loosening the Screws on the 5-1/4" Drive Tray

- Push the drive tray toward the back of the system, and pull up to remove the tray, as shown in Figure 8-14.

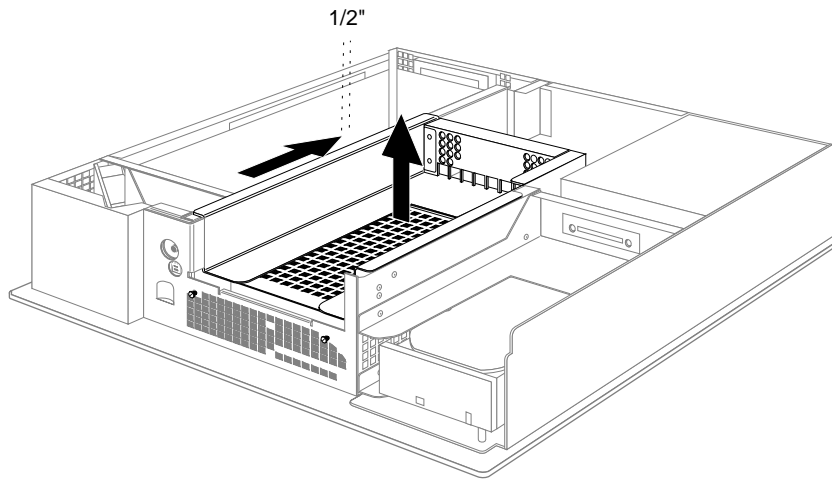

Figure 8-14 Removing the 5-1/4" Drive Tray From the Indigo² Chassis

3. Locate the CPU module.

The CPU module is the large elevated module on the CPU board that is protected by a textured heat sink. It contains the CPU chip, cache, and CPU clock crystal.

The Indigo² workstation supports several CPU module shapes.

- If your system has the R4000 100 MHz CPU module, go to step 4.
- If your system has the R4400 150 MHz CPU module, go to step 5.
- If your system has the R4400 200 MHz CPU module, go to step 6.
- If your system has the R4600 133 MHz CPU module, go to step 7.

4. Remove the R4000 100 MHz CPU module, as shown in Figure 8-15. (Some R4000 modules may look like the module shown in Figure 8-16.)
 - Remove the screws on the corners of the module that attach the CPU module to the board.
 - Disconnect the module connector from the socket on the board by lifting up on the sides of the module and gently rocking it back and forth.
 - Lift the module up and away from the board.
 - Skip to step 8.

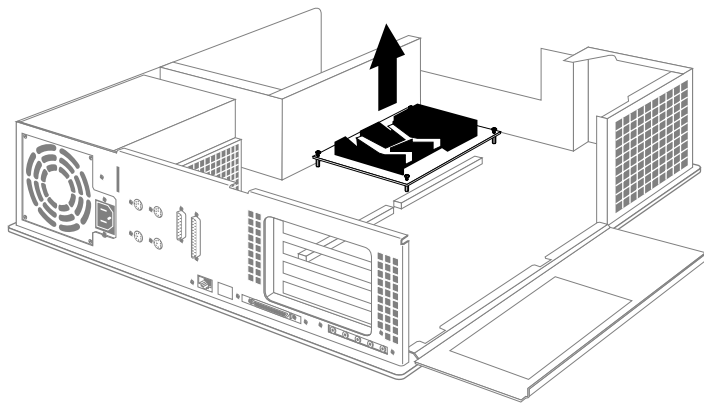

Figure 8-15 Removing the R4000 CPU Module

5. Remove the R4400 150 MHz CPU module, as shown in Figure 8-16.
 - Loosen the four captive screws on the corners of the module that attach it to the system board.
 - Disconnect the module connector from the socket on the system board by lifting up on the edges of the module and gently rocking it back and forth.
 - Lift the module up and away from the board.
 - Skip to step 8.

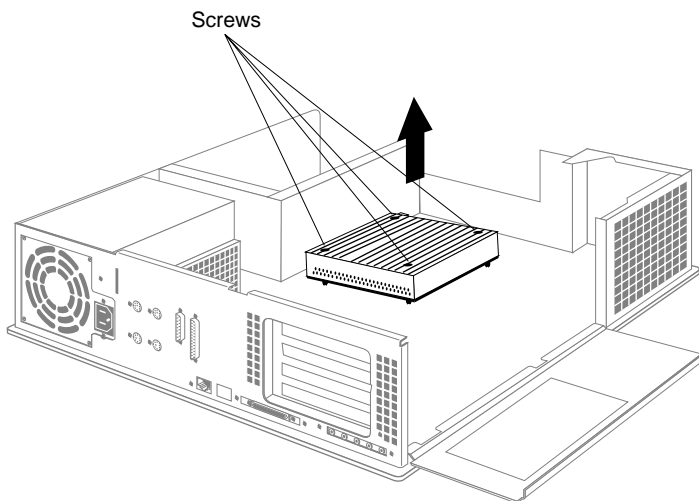

Figure 8-16 Removing the R4400 150 MHz CPU Module

6. Remove the R4400 200 MHz CPU module, as shown in Figure 8-17.
 - Loosen the four captive screws on top of the heat sink.
 - Remove the two Phillips screws on the corners of the module that attach the CPU module to the system board.
 - Disconnect the module connector from the socket on the system board by lifting up on the edges of the module and gently rocking it back and forth.
 - Lift the module up and away from the board.
 - Skip to step 8.

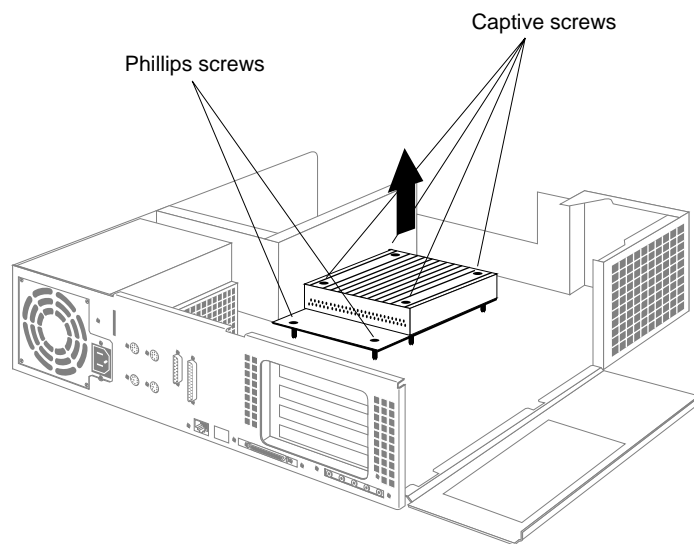

Figure 8-17 Removing the R4400 200 MHz CPU Module

7. Remove the R4600 133 MHz CPU module, as shown in Figure 8-18.
 - Remove 6 Phillips screws that attach the CPU module to the system board.
 - Disconnect the module connector from the socket on the system board by lifting up on the edges of the module and gently rocking it back and forth.
 - Lift the module up and away from the board.

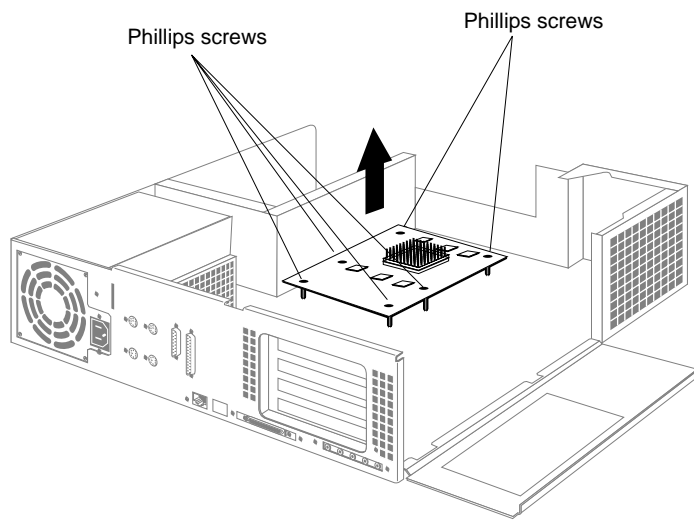

Figure 8-18 Removing the R4600 133 MHz CPU Module

8. Install the new CPU module.
 - Position the new module so that the connector on the bottom of the module aligns with the socket on the board.
 - Press down on top of the module connector until it is securely attached to the socket on the board.
 - If the CPU module has captive screws, tighten the four screws.
 - Insert and tighten any Phillips screws you removed. (The R4400 150 MHz CPU has only captive screws.)

9. Replace the 5-1/4" drive and tray, as shown in Figure 8-19.
 - Position the drive tray so that the tabs on the sides of the tray fit inside the slot openings in the chassis and so that the open side of the tray faces the front of the system.

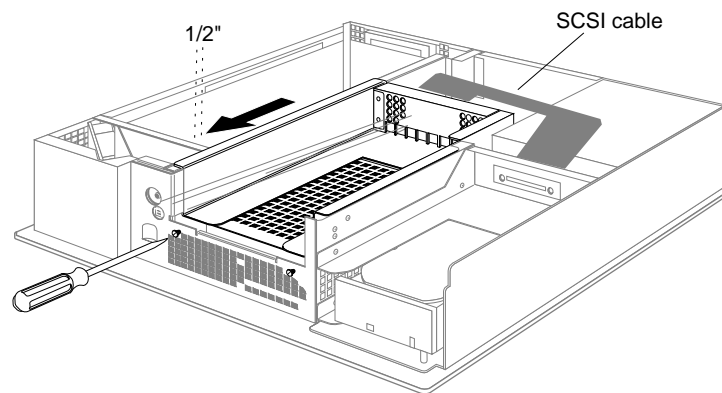

Figure 8-19 Replacing the 5-1/4" Drive Tray

- Push the tray forward about 1/2" to lock it in place.
- Tighten the two captive screws.
- Reattach the SCSI cable to the connector on the back of the drive tray.

You are finished replacing the CPU module. To replace the top cover, turn to "Replacing the Cover" on page 200.

Replacing the Power Supply

To replace the power supply, follow these steps:

1. If you have not already shut down the system, removed the cover, and attached the wrist strap, go to “Replacing Internal Parts” on page 157 for instructions.
2. Remove the power supply.
 - Face the back of the system. The power supply is located on the left, as shown in Figure 8-20.
 - Remove the two screws from the back and side of the chassis.

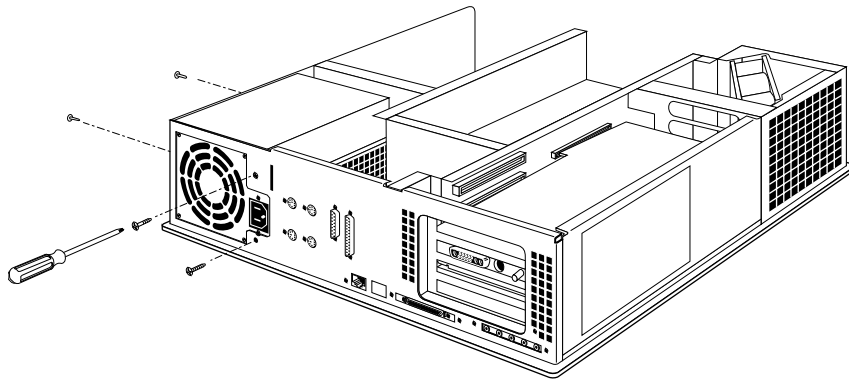

Figure 8-20 Removing the Power Supply Screw

3. Move the system, or position yourself so that you are facing the front of the system, as shown in Figure 8-21.
4. Remove the 5-1/4" drive tray. Removing the drive tray makes it easier to remove the power supply and install the new one. If there is a drive installed, there is no need to remove the drive from the tray.
 - Disconnect the SCSI cable from the connector on the back of the 5-1/4" drive tray. (See Figure 8-21.)
 - Loosen the two captive screws that hold the 5-1/4" drive tray to the chassis. The screws are located below the drive tray in the center front of the system.

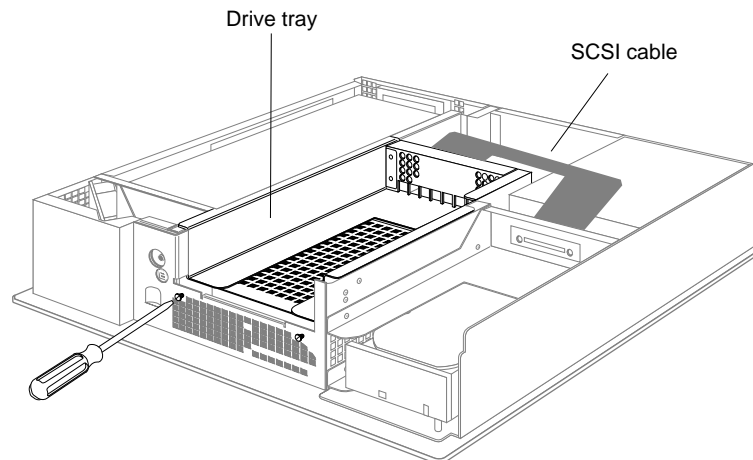

Figure 8-21 Disconnecting the SCSI Cable from the 5-1/4" Drive Tray

- Push the drive tray toward the back of the system, and pull up to remove the tray, as shown in Figure 8-22.

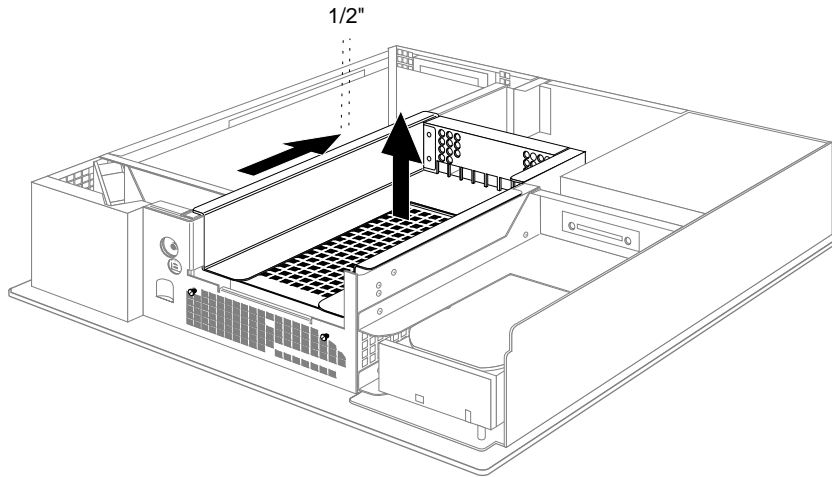

Figure 8-22 Removing the 5-1/4" Drive Tray From the Indigo² Chassis

5. Move the system, or position yourself so that you are facing the back of the system, as shown in Figure 8-23.
6. Disconnect the three power connectors, as shown in Figure 8-23.
 - Disconnect the two connectors located on the side of the power supply near the memory modules by grasping each connector and pulling it straight up.
 - Disconnect the connector located near the disk drives by grasping it and pulling it straight back.

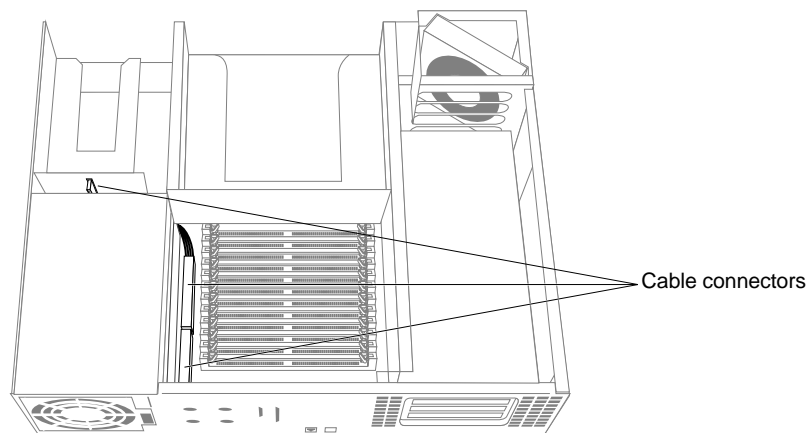

Figure 8-23 Locating the Three Power Supply Cables

7. Remove the power supply.

- Move the power supply toward the front of the system about 1/4", as shown in Figure 8-24, by pushing on the flat surfaces around the fan.

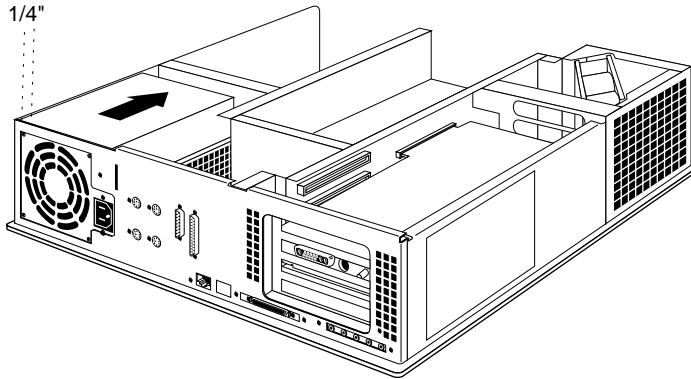

Figure 8-24 Moving the Power Supply Toward the Front of the Chassis

- Lift the power supply up and out of the chassis, as shown in Figure 8-25.

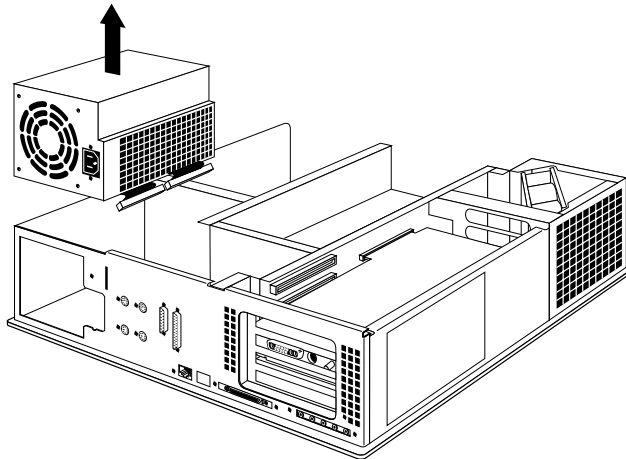

Figure 8-25 Removing the Power Supply From the Indigo² Chassis

8. Before installing the new power supply, connect the power cable located close to the disk drives.

- Hold the power supply with one hand, and with your other hand connect the free end of the power cable shown in Figure 8-26 to the connector located close to the disk drives.

The connector is keyed so that you can connect it only one way if you don't force it.

- Press the connector firmly until seated. Check that it is seated all the way in the socket.

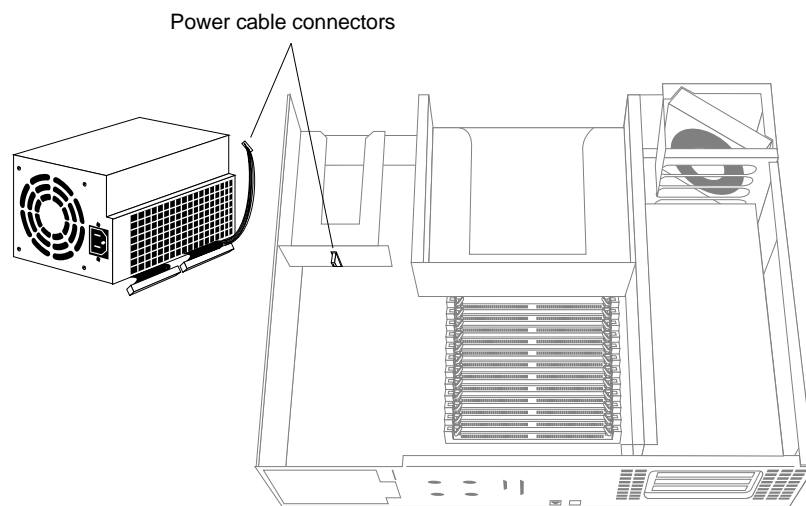

Figure 8-26 Connecting the Power Cable Located Close to the Disk Drives

9. Install the new power supply, as shown in Figure 8-27.
 - Hold the power supply so that the fan faces the back of the chassis and the power cables are at the bottom.
 - Lower the power supply into the Indigo² chassis as close to the disk drives as possible. Make sure that the power supply is flat against the bottom of the chassis.
 - Shove the power supply toward the back of the Indigo² chassis, as far as it will go, making sure the metal tabs on the floor of the chassis engage in the slot underneath the power supply.

If the tabs do not engage in the slot, raise the power supply and lower it again, making sure it is flat against the bottom of the chassis.

Hint: A good test is to lift up the power supply. If the chassis comes up with it, the metal tabs are engaged.

- Replace the four screws that hold the power supply, in the locations shown in Figure 8-27.

If the screw holes do not line up, verify that the power supply is seated all the way, and is pushed all the way against the back of the chassis.

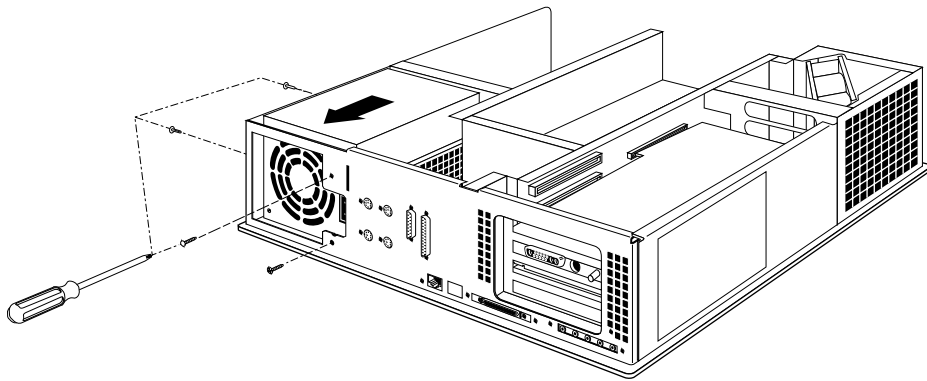

Figure 8-27 Installing the Power Supply

10. Connect the remaining two power cables.

- Connect the two power cables located close to the memory modules, as shown in Figure 8-28. These connectors are not keyed, so make sure you align them correctly before pressing firmly to seat them.
- Check that the two connectors are seated all the way in the sockets.

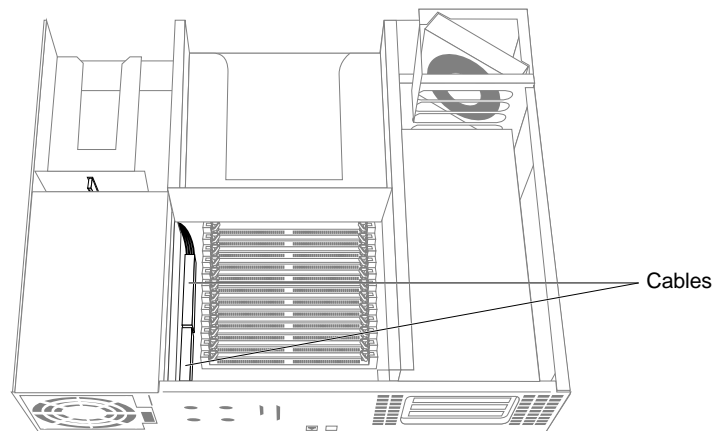

Figure 8-28 Connecting the Power Cables

You are finished replacing the power supply. Turn to “Replacing the Cover” on page 200 to replace the top cover.

Checking and Replacing Faulty SIMMs

Before replacing memory SIMMs, check to make sure that all SIMMs are seated correctly in their slots.

1. If you have not already shut down the system, removed the cover, and attached the wrist strap, go to “Replacing Internal Parts” on page 157 for instructions.

2. Check to see that all the SIMMs are installed correctly.
 - A SIMM is installed correctly when it is vertical and perpendicular to the CPU baseboard, and when the latches on the sides of the SIMM fit snugly around it.
 - If the SIMM appears to be leaning, push it up into a vertical position.
3. Once the SIMMs are all the way in, replace the cover and power up the system. See “Replacing the Cover” on page 200 for instructions.
4. If the error message still says:
Check or replace SIMM#
You have a faulty SIMM. Follow the instructions in “Ordering Replacement Parts” on page 156. Then contact your service provider for further instructions.

Replacing Internal Drives

To replace an internal drive, follow these steps:

1. If you have not already shut down the system, go to “Replacing Internal Parts” on page 157 for instructions.
2. Remove the drive.
 - Push on the ribbed portion of the lever below the drive.
 - Pull the lever all the way to the left.
This releases the drive.
 - Pull the drive all the way out of the slot.
3. Install the new drive.
To install the new drive, follow the instructions in “Installing an Internal Drive” on page 83.

Replacing the CPU Baseboard

To replace the CPU baseboard, follow the steps below to remove the 5-1/4" drive tray, the graphics board set and any EISA boards, the EISA board backplane, the CPU module, and the CPU baseboard. Then replace each item in reverse order.

1. If you have not already shut down the system, removed the cover, and attached the wrist strap, go to "Replacing Internal Parts" on page 157 for instructions.
2. Remove the 5-1/4" drive tray and drive, as shown in Figure 8-29. (There is no need to remove the drive from the tray first.)

- Disconnect the SCSI cable from the connector on the back of the drive tray.
- Loosen the two captive screws holding the 5-1/4" drive tray to the chassis.

The screws are located below the drive tray in the center front of the system.

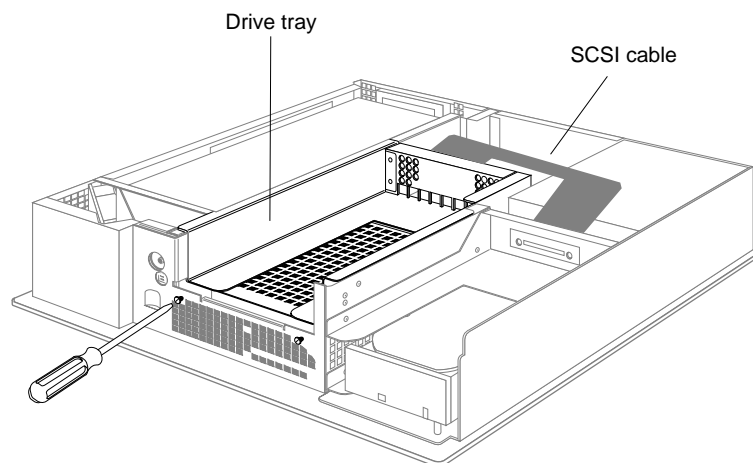

Figure 8-29 Loosening the Screws on the 5-1/4" Drive Tray

- Push the drive tray toward the back of the system about 1/2", and pull up to remove the tray and the drive, as shown in Figure 8-30.

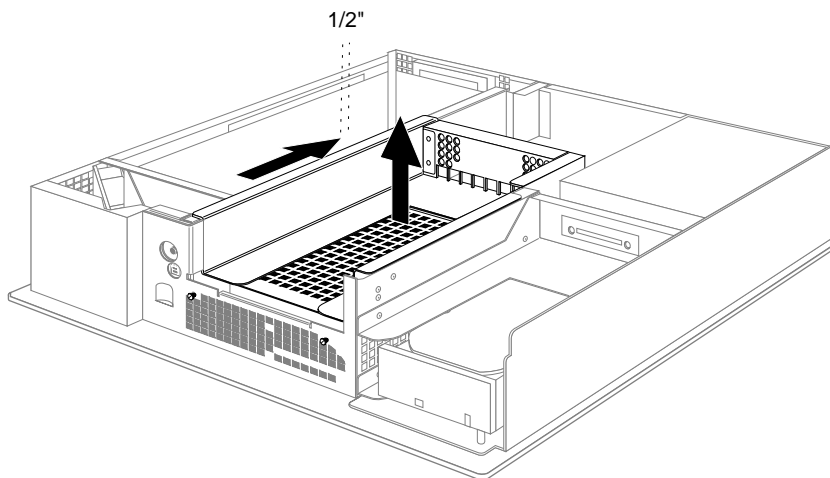

Figure 8-30 Removing the 5-1/4" Drive Tray

3. Remove the graphics board set and any EISA boards.
 - Move the system or position yourself so that you are facing the expansion slots. The slots are located on the left side of the system, behind the internal fan.
 - Open the metal panel in front of the slots by pulling up on the panel and lowering it down, as shown in Figure 8-31.

Figure 8-31 shows an XZ graphics board set. Your system may have an XL (single) or Extreme (triple) graphics board set.

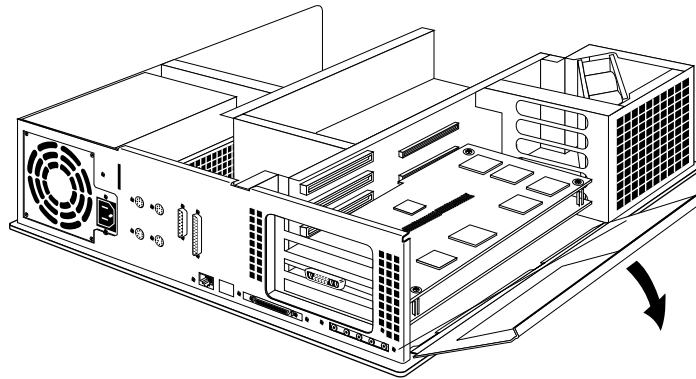

Figure 8-31 Lowering the Metal Panel in Front of the Expansion Slots

4. Remove the screw or screws attaching each board to its expansion slot, as shown in Figure 8-32.

Each board layer has a screw located on the metal extension on the upper left side of the board.

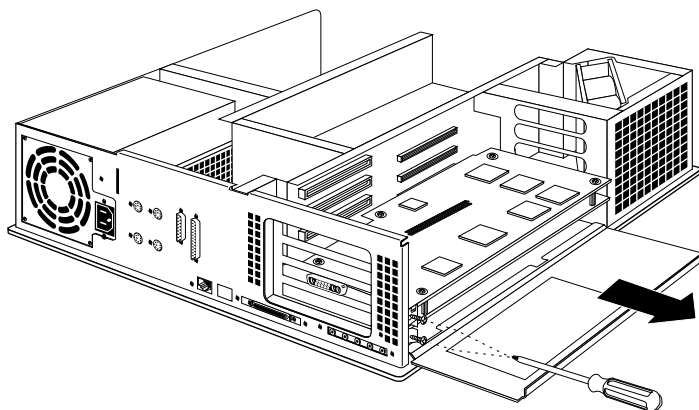

Figure 8-32 Removing the Screws From the Graphics Board Set

5. To remove an XZ or Extreme board set, follow these steps:
 - Turn both hands inward so that your thumbs point to the floor, and place your index fingers behind the small metal posts on each side of the board set. (See Figure 8-33.)
 - Brace your thumbs against the chassis, and pull the board out of the slot. You may need to use some force.
 - Place the board set down on a flat, antistatic surface so the side with the chips faces up. An empty antistatic bag or a clean, dry desktop works well.

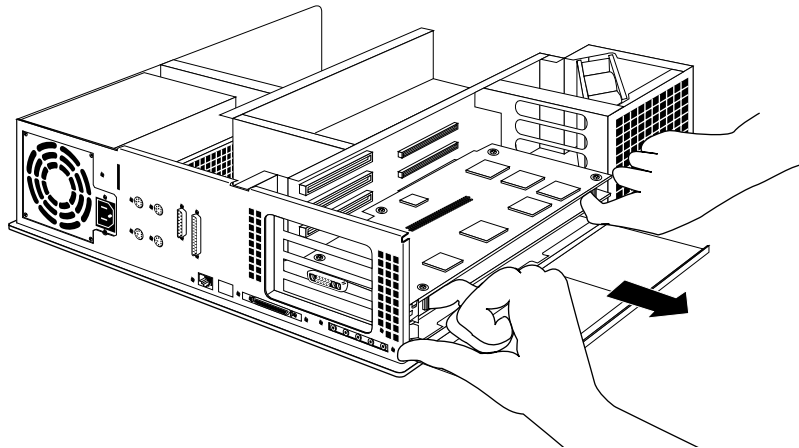

Figure 8-33 Removing the XZ or Extreme Graphics Board Set

6. To remove an XL graphics board, use the two open-ended wrenches provided with the system. (If your XL board has handles attached, use them to extract the board instead of the wrenches.) Follow these steps:

- Grasp the wrenches as shown in Figure 8-34. The orientation of the wrenches is important.

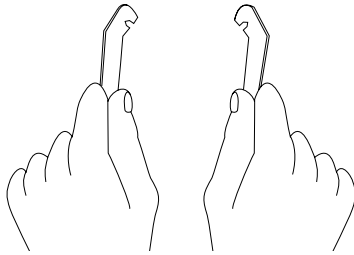

Figure 8-34 Orientation of the Wrenches

- Hook the ends of the wrenches in the small holes on each side of the front of the board, as shown in Figure 8-35.
- Brace your index fingers against the chassis and pry the wrenches outward. The board comes out.

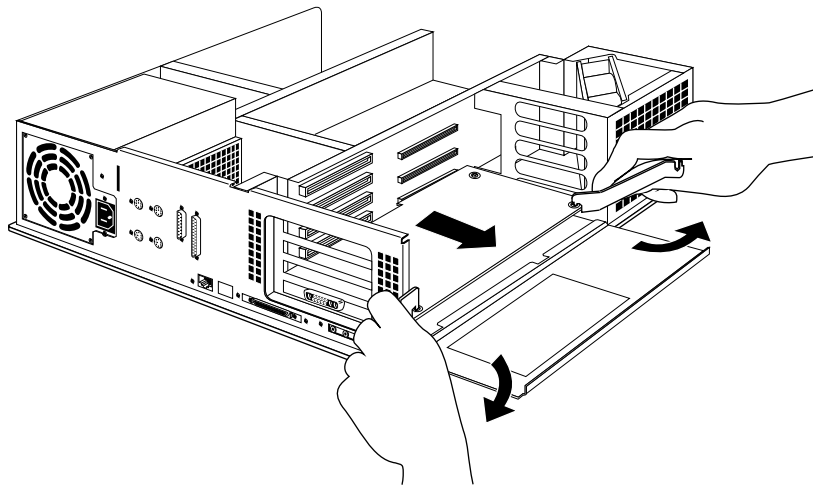

Figure 8-35 Removing the XL Graphics Board

7. Remove the EISA board backplane, as shown in Figure 8-36.

The backplane is the gold-colored metal wall that extends from the fan in the front of the system, along the back of the expansion board slots, to the back of the chassis. The fan is attached to the backplane.

- Remove the screw from the back of the chassis that holds the backplane to the chassis.
- Remove the screw from the center of the backplane that holds the backplane to the CPU baseboard.

Note: Some older Indigo² systems may not have the above two screws.

- Facing the front of the system, remove the backplane by pulling up on the metal tabs located to the right of the fan and on the back of the backplane.

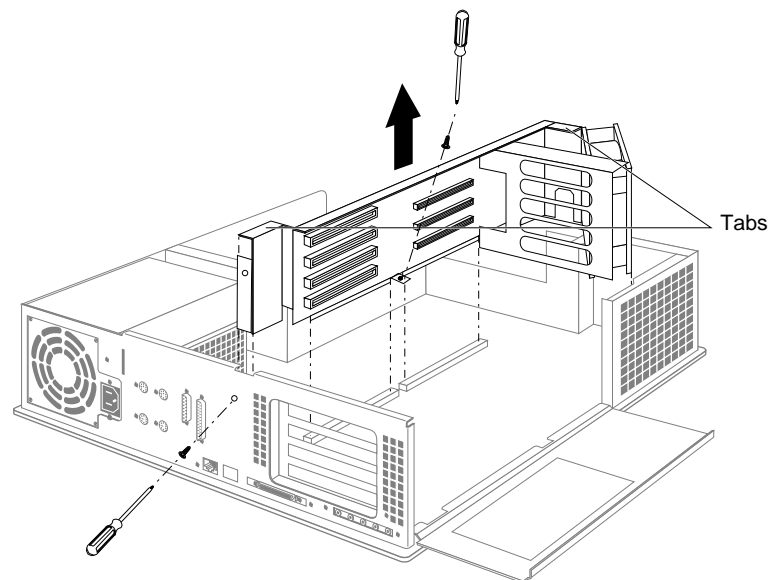

Figure 8-36 Removing the EISA Board Backplane From the Indigo² Chassis

8. Remove the CPU module.

The CPU module is the large, elevated module on the CPU baseboard that is protected by a textured black heat sink. It is located in the middle section of the chassis, in front of the memory SIMMs.

Note: Several CPU module shapes are supported on the Indigo² workstation. Figure 8-37 shows the R4400 150 MHz CPU module. The CPU module on your system may look different, but is located in the same place.

- Loosen any captive screws on the CPU module.
- Use a phillips screwdriver to remove any phillips screws that attach the CPU module and shield to the board. (The R4400 150 MHz has no phillips screws to remove.)
- Disconnect the module connector from the socket on the board by lifting up on the sides of the module and gently rocking it back and forth.
- Lift the module up and away from the board.

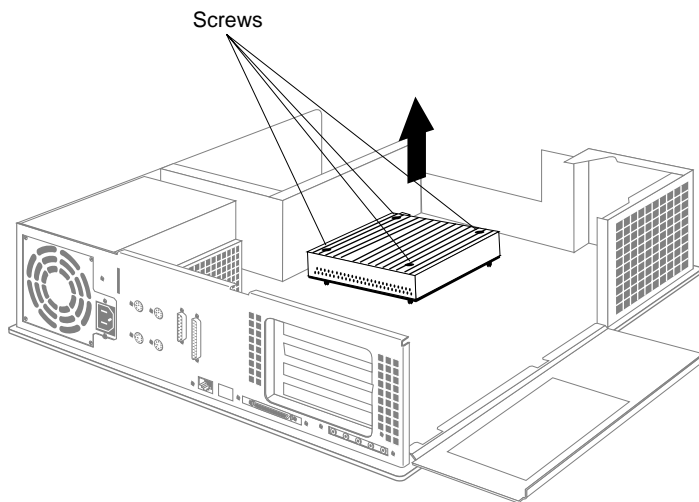

Figure 8-37 Removing the R4400 150 MHz CPU Module From the CPU Baseboard

9. Remove the CPU baseboard.

- Facing the back of the system, disconnect the SCSI cable, the two power supply cables, and the speaker cable from the board, as shown in Figure 8-38.

The speaker cable is attached to the front of the board, toward the front of the system. The SCSI flex cable is attached to the left side of the board, toward the front of the system. The power supply cables are attached to the left side of the board, toward the back of the system.

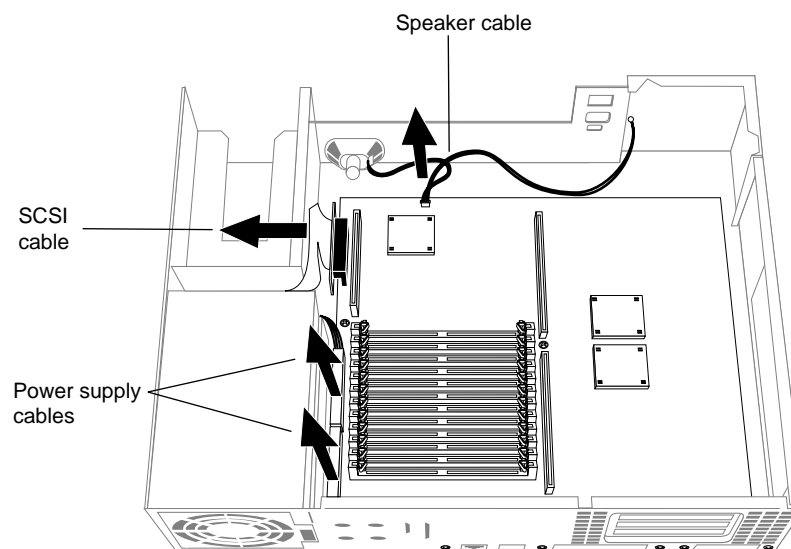

Figure 8-38 Disconnecting the Cables From the CPU Baseboard

- Remove the five screws from the back of the chassis that hold the board to the chassis, as shown in Figure 8-39.

Two of the screws are located on either side of the Ethernet 10-BASE T port. The Ethernet 10-BASE T port looks like a telephone jack. The third screw is located to the right of the SCSI connector. The fourth and fifth screws are located on either side of the audio ports.

- Remove the small screw from the left side of the baseboard, as shown in Figure 8-39.

Note: In some older Indigo² systems the gold screw in the center of the CPU baseboard (as shown in Figure 8-39) should also be removed. In newer systems this screw was already removed when you removed the backplane earlier.

- Pull the board toward the front of the chassis. Then lift it up and out.

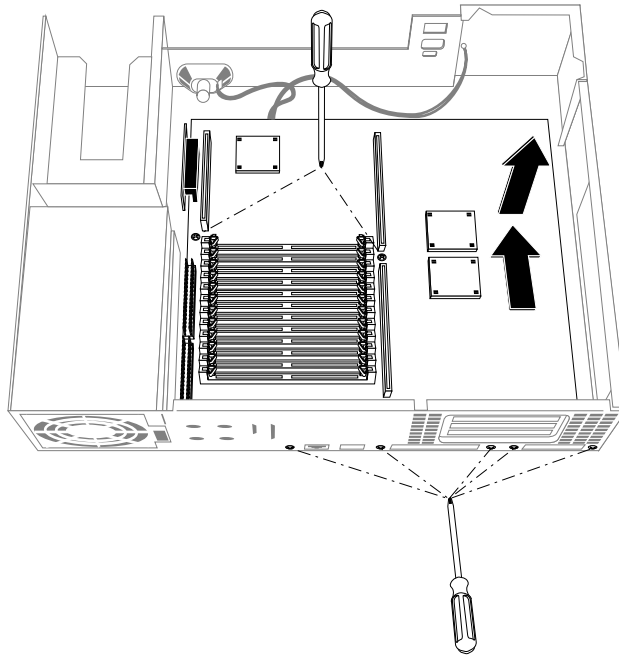

Figure 8-39 Removing the Screws From the Back of the Chassis

10. Install the new CPU baseboard, as shown in Figure 8-40.

- Position the board so that the small connector protruding from the back of the board is facing the back of the chassis.
- Align the open slots in the sides of the board over the slot pins and slide the board down onto the pins. You may need to hold up the connectors toward the back right side of the chassis in order to slide the board into position.
- Slide the board toward the back of the chassis as far as it will go.

Hint: If you don't push the board all the way back, the connectors on the backplane may not align correctly with the ports on the board.

- Insert and tighten the five screws that you removed from the back of the chassis.
- Insert and tighten the screw that you removed from the CPU baseboard.

Note: If you have an older Indigo² system that does not have a bracket on the EISA backplane, also insert and tighten the gold screw in the center of the CPU baseboard.

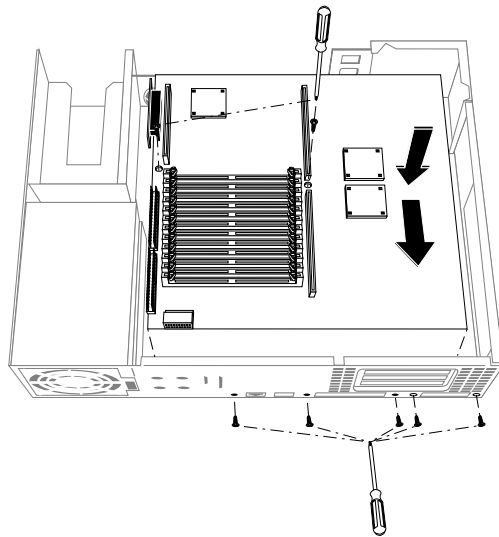

Figure 8-40 Installing the CPU Baseboard in the Indigo² Chassis

- Reattach the SCSI flex cable connector to the port on the forward right side of the board.
 - Reattach the power cables and speaker cable to the board.
11. Replace the CPU module. Figure 8-41 shows the R4400 150 MHz CPU module. Your CPU module may look different, but is installed in the same location.
- Position the module so that the connector on the bottom of the module aligns with the connector on the board, as shown in Figure 8-41.

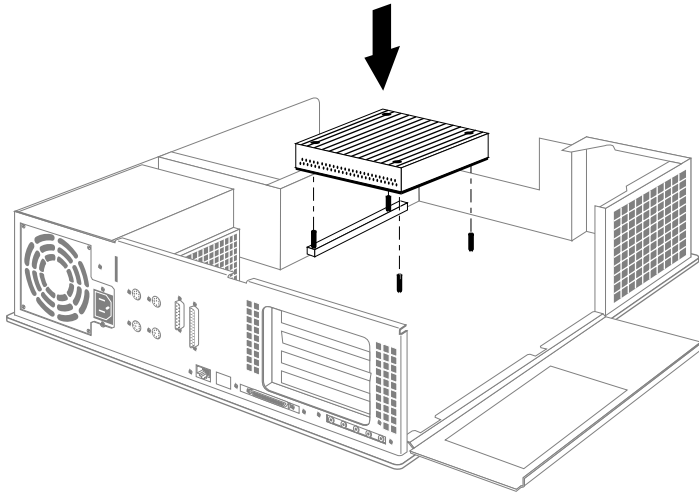

Figure 8-41 Installing the R4400 150 MHz CPU Module in the Indigo² Chassis

- Press down on the top of the module connector until it is firmly attached to the socket on the board.
- Tighten each of the captive screws to secure the module to the board. If your CPU module has additional phillips screws, insert and tighten them.

12. Replace the EISA board backplane, as shown in Figure 8-42.

- Position the backplane so that the fan is aligned over the slot openings in the forward left side of the chassis, and the back end of the backplane is aligned over the slot in the back side of the chassis.
- Slide the backplane down into the chassis.
- Press firmly so that the connectors on the backplane fit securely into the ports on the CPU baseboard. If the connectors do not align correctly with the ports, the CPU baseboard may not be pushed all the way back

Hint: If you're having trouble inserting the EISA backplane, tilt up the chassis and place one hand underneath the center of the chassis while you push down on the backplane.

- Insert and tighten the screws that hold the EISA backplane to the back of the chassis and the center of the CPU baseboard. (Some older Indigo² systems may not have these screws.)

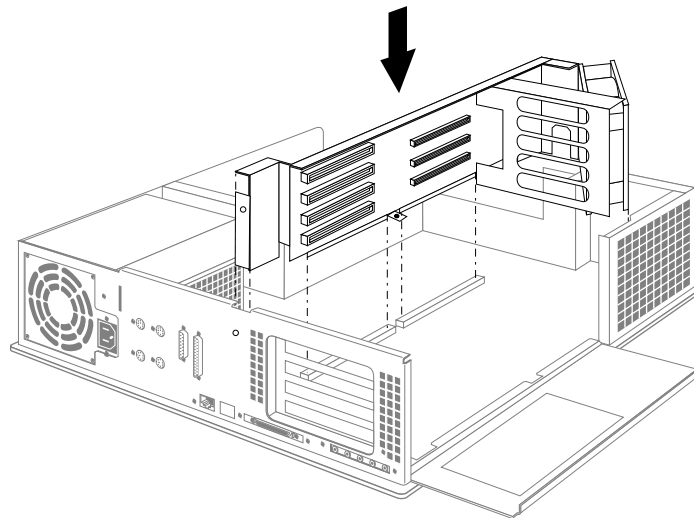

Figure 8-42 Installing the EISA Board Backplane in the Indigo² Chassis

13. Replace the graphics board or board set and any EISA boards.

- Move the system or position yourself so that you are facing expansion slots. Expansion slots are located on the left side of the system, behind the internal fan.

Note: Figure 8-43 shows an XZ board set. You install an XL board or Extreme board set the same way.

- Align the right side of the board or board set with the metal grooves on the right. Align the connector on the left side of the board or board set with the connector opening on the left, as shown in Figure 8-43.

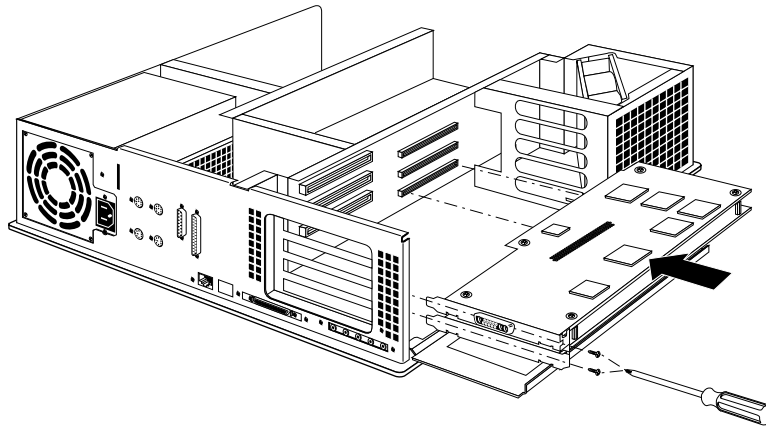

Figure 8-43 Installing the Graphics Board Set in the Indigo² Chassis

- Push the board or board set into the slot until the connector on the back of the board is securely connected to the port on the backplane.
- Insert and tighten the screws that hold the board or board set to the chassis. The screw openings are located on the metal extension on the upper left side of each board.

14. Install the 5-1/4" drive and tray, as shown in Figure 8-44.

- Position the drive tray so that the tabs on the sides of the tray fit inside the slot openings in the chassis and so that the open side of the tray faces the front of the system.
- Push the tray forward to lock it in place.
- Tighten the two captive screws.
- Reattach the SCSI cable to the connector on the back of the drive tray.

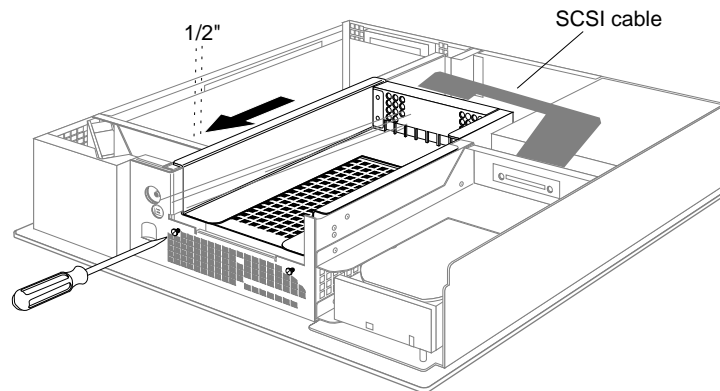

Figure 8-44 Installing the 5-1/4" Drive Tray in the Indigo² Chassis

You are now finished replacing the CPU baseboard. Turn to "Replacing the Cover" on page 200 to replace the cover.

Replacing the Cover

To replace the top cover, follow these steps:

1. Place the prongs on the underside of the cover into the slots under the top ridge of the backplane of the chassis, as shown in Figure 8-45.
2. Lower the cover down onto the chassis until it snaps into place.

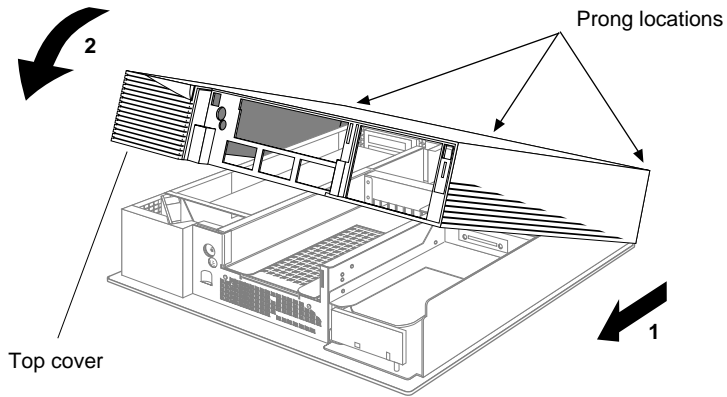

Figure 8-45 Replacing the Top Cover on the Indigo² Chassis

3. Replace the front bezel.
 - Place the tabs on the bottom of the bezel in the grooves in the front of the chassis, as shown in Figure 8-46.
 - Tilt the bezel up and snap it into place.
4. Reconnect the power cable to the back of the system.

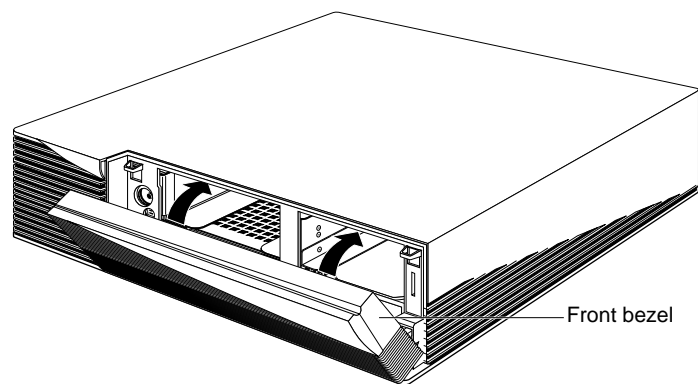

Figure 8-46 Replacing the Front Bezel on the Indigo² Chassis

You are finished replacing the part and are ready to start up the system.

Replacing External Parts

External replacement parts include the keyboard, mouse, and external SCSI devices. To replace an external part on the Indigo², shut down the system, replace the part, then start up the system.

Shutting Down and Powering Off the System

To shut down and power off the system, follow these steps:

1. Open the front cover.
2. Press and release the power switch on the front of the system to shut down the software and power off the system.

The system powers off automatically.

3. Press the monitor power switch to turn off your monitor.
4. Disconnect the power cable from back of the Indigo² workstation.

To replace the keyboard or mouse, see below for instructions. To replace an external SCSI device, turn to “Replacing External SCSI Devices” on page 203.

Replacing the Keyboard or Mouse

To replace the keyboard or mouse, follow these steps:

1. See “Shutting Down and Powering Off the System” on this page to shut down the system.
2. Disconnect the cable from the main unit.
3. Connect the new mouse or keyboard to the main unit.
4. Reconnect the power cable to the back of the system.
5. Press and release the power switch on the monitor. Then press and release the power switch on the front of the system to power up the system.

Replacing External SCSI Devices

To replace an external SCSI device, follow these steps:

1. Turn to “Shutting Down and Powering Off the System” on page 202 to shut down the system.
2. Disconnect the power cable from the SCSI device.
3. Disconnect the SCSI cable from the back of the Indigo² chassis.
 - Squeeze the clips on both sides of the connector.
 - Pull off the connector.
4. If you are not going to install another external device, replace the terminator that came with your workstation on your Indigo².

Note: The terminator that shipped with your Indigo² is a high-density active terminator. The terminator on an external drive may be a low-density terminator. Use only an active high-density terminator to terminate the Indigo².

- Gently put the terminator on the SCSI connector on the back of the Indigo² chassis.

The SCSI connector is designed so that you can put the terminator on only one way, if you do not force it.

- Secure the clips on each side of the terminator.
5. Reconnect the power cable to the back of the system.
 6. Press and release the power switch on the monitor. Then press and release the power switch on the front of the system to power up the system.

To install a replacement external SCSI device, follow the instructions in “Installing External SCSI Devices” on page 90.

Safety, Maintenance, and Regulatory Information

This chapter provides guidelines for adjusting your work surface and environment to increase your comfort and safety. It also contains regulatory statements.

Safety, Maintenance, and Regulatory Information

This chapter gives you information on safety and comfort and some helpful hints on maintaining your IRIS Indigo². It also gives you important regulatory information.

Maintaining Your Hardware and Software

This section gives you some basic guidelines to follow to keep your hardware and the software that runs on it in good working order.

Hardware Do's and Don'ts

To keep your workstation in good running order, follow these guidelines:

Do not

- enclose the workstation in a small, poorly ventilated area (such as a closet), crowd other large objects around it, or drape anything (such as a jacket or blanket) over the workstation
- use the workstation as a shelf or a table
- run the workstation with the front bezel or top open or off; this alters the air flow
- connect cables (other than audio) or add hardware components while the workstation is turned on
- move the workstation while it is running, or within 1 minute of powering it down; it contains a hard disk that may be damaged
- use an adapter to plug the workstation into a two-pronged (ungrounded) outlet
- place liquids or food on the workstation or keyboard
- lay the workstation on its side without using the workstation stand that shipped with the system

- dangle the mouse by its cable or throw the mouse at co-workers

Do

- plug in all cables completely
- plug the workstation into a power surge protection strip (if possible)

Software Do's and Don'ts

When your system is up and running, follow these guidelines:

Do not

- use the root account unless you are performing administrative tasks

Do

- make regular backups (weekly for the whole system, nightly for individual users) of all information
- protect the root account with a password
- protect all open accounts (such as lp, guest, and so on) with a password, if your system is connected to the Internet

Human Factors Guidelines for Setting up Your Indigo² Workstation

You can increase the comfort and safety of your work environment, and decrease your chances of cumulative trauma disorders, by following the guidelines given below. These guidelines will help you to create a healthy and productive work environment by:

- using your Indigo² workstation correctly
- properly choosing a site for your system and its components
- setting up your desk and chair correctly

ANSI Standard for Visual Display Terminal (VDT) Workstations

Table 9-1 shows recommended guidelines for furniture and system adjustment, as developed by the American National Standards Institute (ANSI).¹

¹ *American National Standard for Human Factors Engineering of Visual Display Terminal Workstations.* ANSI/HFS 100-1988. Available through the Human Factors Society, Inc. P.O. Box 1369, Santa Monica CA 90406, USA.

Local VDT guidelines issued by country, state, or municipality may apply and supercede the guidelines in Table 9-1.

Table 9-1 ANSI/HFS 100-1988 Guidelines for VDT Workplace Adjustment

Adjustment	Small Female cm (in)	Midpoint cm (in)	Large Male cm (in)
Seat pan height	40.6 (16.0)	46.3 (18.2)	52.0 (20.5)
Work surface height (keyboard and mouse)	58.5 (23.0)	64.75 (25.5)	71.0 (28.0)
Screen viewing height	103.1 (40.6)	118.1 (46.5)	133.1 (52.4)
Screen viewing distance	>30.5 (>12)	>30.5 (>12)	>30.5 (>12)
Screen viewing angle	0-60 degrees	0-60 degrees	0-60 degrees

Adjustment parameters are defined in Figure 9-1. Guidelines are shown for small females (standing height of 150 cm or 59 in.) and large males (standing height of 185 cm or 73 in.). Midpoints are also interpolated for persons of more average height.

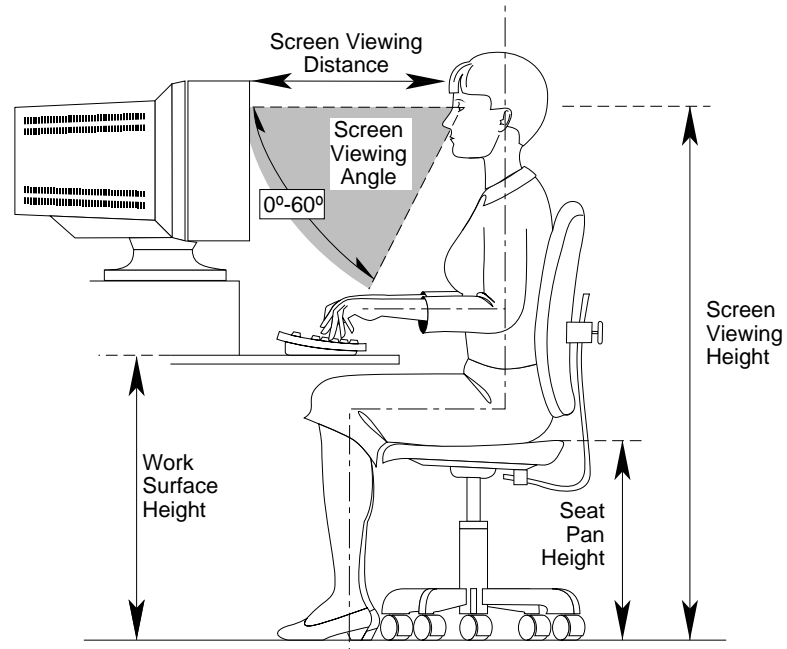

Figure 9-1 Basic Parameters of VDT Workstation Adjustment (Adapted From ANSI/HFS 100-1988)

Computer Aided Design (CAD) Operator Preferences

If you work on a CAD system, you may feel more comfortable using the ranges of adjustment shown in Table 9-2.

Table 9-2 Workstation Adjustments Preferred by CAD Users^a

Adjustment cm (in.)	Mean cm (in.)	Range cm (in.)
Seat pan height	54 (21.3)	50-57 (19.7-22.4)
Work surface height	73 (28.7)	70-80 (27.6 -31.5)
Monitor center above floor	113 (44.5)	107-115 (42.1-45.3)
Screen viewing distance	70 (27.6)	59-78 (23.2-30.7)
Work surface tilt	8.6 degrees	2-13 degrees
Monitor tilt ^b	-7.7 degrees	-15 - +1 degrees

a. Derived from Grandjean, Etienne. *Ergonomics in Computerized Offices*. London: Taylor & Francis Ltd., 1987, p. 148.

b. negative tilt = a forward monitor inclination (top of the screen toward the operator)

Tips for Setting Up and Using Your Workstation

The following tips may be useful for setting up an ergonomic work environment that is safe, comfortable, and productive. Although you may be able to perform this procedure yourself, it is useful to work with a friend to achieve the best fit.

Facilities Selection

1. A good work chair should swivel, and you should be able to adjust the seat height while sitting. The seat should have a rounded front edge. The chair should have a large enough base to remain stable when adjusted to its maximum height. It should have castors or glides. Many chairs rock, which may partially relieve the muscle tension from sitting in a fixed position. Some chairs can also be adjusted for seat tilt and depth, armrest height, backrest angle, and lower back support. Check the instructions that came with your chair to take advantage of its adjustability features.
2. Select a work surface that provides enough space to do your work without excessive turning, twisting, or stretching. The height of the work surface should be adjustable and, if possible, it should be wide enough to use the mouse and keyboard at the same height. This helps your neck, shoulders, and upper arms to stay relaxed while you work.
3. Indirect lighting should be used, whenever possible, to prevent glare on the display screen. If you prefer lower levels of lighting (for example, 200-250 lx) than usually found in offices, separate task lighting may be needed for reading documents. Wearing darker-colored clothing helps minimize glare reflections on the screen.

Adjusting Your Chair, Work Surface, and Indigo²

1. Adjust your chair first, from a seated position if possible. Your lower leg and thigh should form approximately a 90-degree angle at the knee, and your feet should rest flat on the floor. If you are short, you may want to use a footrest for better comfort.
2. Once your chair is adjusted, raise or lower your work surface to a height that allows you to keep the wrists flat and straight while using the keyboard and mouse. The angle between your lower and upper arm should be 70-90 degrees at the elbow. If necessary, use a padded wrist rest under the keyboard to support your wrists.
3. To minimize screen glare, position your monitor screen perpendicular to overhead lighting sources and windows. Do not set the monitor in front of or behind a window, or parallel to other sources of light. Tilting the screen forward slightly

helps avoid glare. Adjusting the monitor controls to minimize brightness and maximize contrast may also reduce the effects of glare.

4. Adjust your monitor height so that your line of sight in your regular seated position is at or near the top the screen. You should be able to see the whole screen without tilting your head forward or backward, within a 60-degree viewing angle of the normal line of sight. With smaller monitors, this may require using a display stand under the monitor base. With larger monitors, it may require a longer viewing distance (see Table 9-2).
5. These adjustment steps should be done each time a different person uses the workstation.

Workstation Usage

1. When using the keyboard, mouse, or other input devices, keep the wrists flat as much as possible, and do not rotate the hands inward toward the thumbs or outward toward the fingers.
2. Electronic keyboards and input devices do not require as much force to operate as manual typewriters. Type or click lightly on the keyboard or mouse.
3. Document stands can be mounted on the work surface or swing out on an arm to position documents next to the display. These can be helpful in maintaining a healthy posture for using the workstation (head in approximately a straight line with the body).
4. You may find it helpful to take rest breaks of several minutes every one to two hours. During breaks, focus your eyes on objects or scenery at least 30 feet away, stretch, and move around.

Manufacturer's Regulatory Declarations

Note: Your workstation has several governmental and third-party approvals, licenses, permits. Do not modify this product in any way that is not expressly approved by Silicon Graphics. If you do, you may lose these approvals and your governmental agency authority to operate this device.

The Indigo² workstation conforms to several national and international specifications and European Directives listed on the "Manufacturer's Declaration of Conformity." The CE insignia displayed on each device is an indication of conformity to the European requirements.

Manufacturer's Declaration of Conformity

A "Manufacturer's Declaration of Conformity" is available on the World Wide Web. Look on your system (regulatory) label on the rear of your workstation to determine your CMN (model) number which you will need to identify your Declaration of Conformity.

To locate the information on the World Wide Web, enter the following in your Web browser location window:

`http://www.sgi.com/Products/compliance/index.html`

Locate and print or save your Declaration of Conformity. For future reference, make a note of your CMN number and the date on the Declaration of Conformity here:_____.

Electromagnetic Emissions

This device complies with the Class A limits of Part 15 of the FCC Rules. Operation is subject to the following two conditions:

- This device may not cause harmful interference.
- This device must accept any interference received, including interference that may cause undesired operation.

This equipment does not exceed the Class B limits of Canada's Department of Communications Radio Interference Regulations for radio noise emissions.

This device complies with Class B electromagnetic emissions limits of C.I.S.P.R. Publication 22, Limits and Methods of Measurement of Radio Interference Characteristics of Information Technology Equipment, Germany's BZT Class B limits for Information Technology Equipment, and with Japan's VCCI Class 2 limits.

この装置は、第二種情報装置（住宅地域又はその隣接した地域において使用されるべき情報装置）で住宅地域での電波障害防止を目的とした情報処理装置等電波障害自主規制協議会（VCCI）基準に適合しております。

しかし、本装置をラジオ、テレビジョン受信機に近接してご使用になると、受信障害の原因となることがあります。

取扱説明書に従って正しい取り扱いをして下さい。
VCCI-2、CISPR-22 Class B

Caution: Do not modify this product in any way that is not expressly approved by Silicon Graphics. If you do, you may lose your FCC or other government agency authority to operate this device.

Radio and Television Interference

The equipment described in this guide generates and uses radio frequency energy. If it is not installed and used in accordance with the instructions in this guide, it can cause radio and television interference.

This equipment has been tested and complies with the limits for a Class A computing device in accordance with the specifications in Part 15 of FCC rules. These specifications are designed to provide reasonable protection against such interference in an industrial or office installation. However, there is no guarantee that the interference will not occur in a particular installation. This system is not certified for home use.

You can determine whether your system is causing interference by turning it off. If the interference stops, it was probably caused by the workstation or one of the peripherals. To tell if the interference is caused by one of the peripherals, try disconnecting one peripheral at a time to see if the interference stops. If it does, that peripheral is the cause of the interference.

If your workstation does cause interference to radio or television reception, try to correct the interference by using one or more of the following suggestions:

- Turn the television or radio antenna until the interference stops.
- Move the workstation to one side or the other of the radio or television.
- Move the system farther away from the radio or television.
- Plug the system into an outlet that is on a different circuit from the radio or television. (That is, make certain the workstation and the radio or television are on circuits controlled by different circuit breakers or fuses.)

Shielded Cables

The Indigo² workstation is FCC-compliant under test conditions that include the use of shielded cables between Indigo² and its peripherals. Your Indigo² and any peripherals you purchase from Silicon Graphics have shielded cables. Shielded cables reduce the possibility of interference with radio, television, and other devices. If you use any cables that are not from Silicon Graphics, make sure they are shielded. Telephone cables do not need to be shielded.

In Germany, a shielded cable must be used on the Ethernet 10-BASE T port.

The monitor cable supplied with your system uses additional filtering molded into the cable jacket to reduce radio frequency interference. Always use the cable supplied with your system. If your monitor cable becomes damaged, a replacement cable should be obtained from Silicon Graphics.

Electrostatic Discharge

Silicon Graphics designs and tests its products to be immune to effects of electrostatic discharge (ESD). ESD is a source of electromagnetic interference and can cause problems ranging from data errors and lockups to permanent component damage.

It is important that while you are operating your IRIS Indigo² you keep all the covers and doors, including the plastics, in place. The shielded cables that came with the system and its peripherals should be installed correctly, with all thumbscrews fastened securely.

An ESD wrist strap is included with some products, such as memory and graphics upgrades. The wrist strap is used when installing these upgrades to prevent the flow of static electricity, and it should protect your system from ESD damage.

Limited User Warranty

Silicon Graphics, Inc. warrants this IRIS hardware product, option or accessory against defects in material and workmanship for a period of ninety (90) days after the date of its original retail purchase (the "Warranty Period"). If you discover a defect in the Product during the Warranty Period, Silicon Graphics will, at its sole option, repair or replace the Product at no charge to you, provided that you (i) return the product (transportation charges prepaid) during the Warranty Period to the authorized Silicon Graphics dealer (or Silicon Graphics service center, if purchased directly from Silicon Graphics) from whom it was purchased, or return it to another authorized Silicon Graphics dealer in the country of its original purchase, and (ii) have included a copy of a bill of sale bearing the appropriate Silicon Graphics serial number as proof of the original date and location of the Product's purchase. This warranty applies only to hardware products manufactured by or for Silicon Graphics and distributed under Silicon Graphics' trademarks, and does not apply to any (i) Silicon Graphics software accompanying the Product, which is licensed under a separate statement included with the software, (ii) Product that has been damaged by abuse, accident, misuse, misapplication or improper installation, and (iii) any Product that has been modified or has had its serial number removed or defaced.

The warranties and remedies specified above are exclusive, and are in lieu of, and Silicon Graphics disclaims, all others, express, implied, oral or otherwise, including, without limitation, any warranty of merchantability or fitness for a particular purpose. No oral or written information or advice given by Silicon Graphics, or its dealers or distributors, will create a warranty or increase the scope of this warranty, and you may not rely on such information or advice. Some states do not allow the exclusion of implied warranties, so the exclusion above may not apply to you. Any applicable implied warranties are limited in duration to the period of time specified above. This warranty gives you specific legal rights, and you may have other rights that vary from state to state. Silicon Graphics is not liable for any special, consequential, incidental or indirect damages of any kind (including without limitation loss of profits, data or goodwill, or property damage), whether or not Silicon Graphics has been advised of the possibility of such loss, however caused and on any theory of liability, arising out of the use of the product, or resulting from a breach of this warranty. These limitations shall apply notwithstanding the failure of the essential purpose of any limited remedy. Silicon Graphics' liability for actual damages for any cause whatsoever, regardless of the form of action, will be limited to the net amount paid by you for the purchase of the Product that caused the damages or is directly related to the cause of action. Some states do not allow the limitation or exclusion of liability for incidental or consequential damages, so this limitation may not apply to you.

Silicon Graphics, Inc.
2011 N. Shoreline Blvd.
Mountain View, CA 94039-7311

Appendix A

Cable Pinout Assignments

This appendix provides cable pinout assignments for the external ports on the Indigo² workstation.

Cable Pinout Assignments

This appendix contains cable pinout information for the following ports located on the back of the Indigo² workstation:

- serial
- parallel
- Ethernet 10-BASE T
- Ethernet AUI
- keyboard
- mouse
- SCSI
- audio

Serial Ports

Tables A-1 and A-2 show cable pinout assignments for the serial ports.

Table A-1 4D Compatible Pin Assignments (RS-232)

Pin	Assignment	Description
1	DTR	Data Terminal Ready
2	CTS	Clear To Send
3	TD	Transmit Data
4	SG	Signal Ground
5	RD	Receive Data
6	RTS	Request To Send
7	DCD	Data Carrier Detect
8	SG	Signal Ground

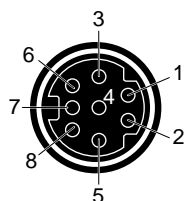

Figure A-1 Serial Port Pinout Assignments

Table A-2 Macintosh SE Compatible Pin Assignments (RS-422)

Pin	Assignment	Description
1	HSKo	Output Handshake
2	HSKi	Input Handshake Or External Clock
3	TxD-	Transmit Data -

Table A-2 Macintosh SE Compatible Pin Assignments (RS-422)

Pin	Assignment	Description
4	GND	Signal Ground
5	RxD-	Receive Data -
6	TxD+	Transmit Data +
7	GPi	General Purpose Input
8	RxD+	Receive Data +

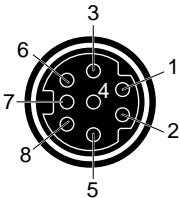

Figure A-2 Serial Port Pinout Assignments

Parallel Port

Table A-3 shows the cable pinout assignments for the parallel port.

Table A-3 Parallel Port (25-pin DSUB Connector)

Pin	Assignment
1	STROBE
2	DATA(0)
3	DATA(1)
4	DATA(2)
5	DATA(3)
6	DATA(4)

Table A-3 (continued) Parallel Port (25-pin DSUB Connector)

Pin	Assignment
7	DATA(5)
8	DATA(6)
9	DATA(7)
10	ACK
11	BUSY
12	PE (Paper End)
13	SELECT
14	AUTOFEED
15	ERROR/FAULT
16	INIT/RESET
17	SELECT-IN (Direction)
18	GROUND
19	GROUND
20	GROUND
21	GROUND
22	GROUND
23	GROUND
24	GROUND
25	GROUND

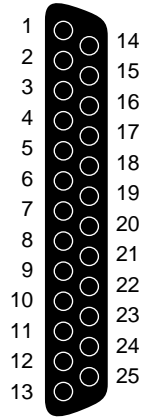

Figure A-3 Parallel Port Pinout Assignments

Ethernet 10-BASE T

Table A-4 shows the cable pinout assignments for the Ethernet 10-BASE T port.

Table A-4 Ethernet 10-BASE T Port

Pin	Assignment
1	TRANSMIT+
2	TRANSMIT-
3	RECEIVE+
4	(Reserved)
5	(Reserved)
6	RECEIVE-
7	(Reserved)
8	(Reserved)

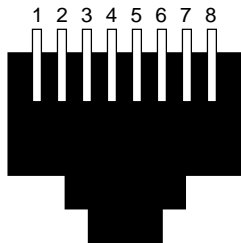

Figure A-4 Ethernet 10-BASE T Port Pinout Assignments

Ethernet AUI

Table A-5 shows the cable pinout assignments for the Ethernet AUI port.

Table A-5 Ethernet AUI Port (Thicknet)

Pin	Assignment
1	GROUND
2	COLLISION+
3	TRANSMIT+
4	GROUND
5	RECEIVE+
6	GROUND
7	(Reserved)
8	GROUND
9	COLLISION-
10	TRANSMIT-
11	GROUND
12	RECEIVE-
13	+12V

Table A-5 Ethernet AUI Port (Thicknet)

Pin	Assignment
14	GROUND
15	(Reserved)

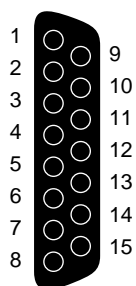
**Figure A-5** Ethernet AUI Port Pinout Assignments

Keyboard

Table A-6 shows the cable pinout assignments for the keyboard port.

Table A-6 Keyboard Port (6-pin MINIDIN)

Pin	Assignment
1	KEYBOARD DATA
2	(Reserved)
3	GROUND
4	KEYBOARD POWER (+5V)
5	KEYBOARD CLOCK
6	(Reserved)

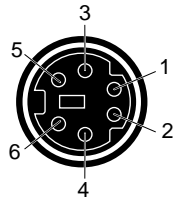

Figure A-6 Keyboard Port Pinout Assignments

Mouse

Table A-7 shows the cable pinout assignments for the mouse port.

Table A-7 Mouse Port (6-pin MINIDIN)

Pin	Assignment
1	MOUSE DATA
2	(Reserved)
3	GROUND
4	MOUSE POWER (+5V)
5	MOUSE CLOCK
6	(Reserved)

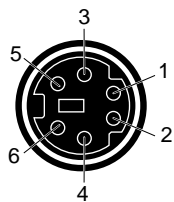

Figure A-7 Mouse Port Pinout Assignments

SCSI Port

Table A-8 shows the cable pinout assignments for the SCSI port.

Table A-8 SCSI Port

Pin	Assignment
1	GROUND
2	GROUND
3	GROUND
4	GROUND
5	GROUND
6	GROUND
7	GROUND
8	GROUND
9	GROUND
10	GROUND
11	GROUND
12	Reserved
13	Open
14	Reserved
15	GROUND
16	GROUND
17	GROUND
18	GROUND
19	GROUND
20	GROUND
21	GROUND

Appendix A: Cable Pinout Assignments

Table A-8 (continued) SCSI Port

Pin	Assignment
22	GROUND
23	GROUND
24	GROUND
25	GROUND
26	DB(0)
27	DB(1)
28	DB(2)
29	DB(3)
30	DB(4)
31	DB(5)
32	DB(6)
33	DB(7)
34	DB(P)
35	GROUND
36	GROUND
37	Reserved
38	TERMPWR
39	Reserved
40	GROUND
41	ATN
42	GROUND
43	BSY
44	ACK
45	RST

Table A-8 (continued) SCSI Port

Pin	Assignment
46	MSG
47	SEL
48	C/D
49	REQ
50	I/O

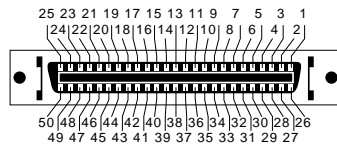

Figure A-8 SCSI Port Pinout Assignments

Audio

Table A-9 shows the cable pinout assignments for the audio ports.

Table A-9 Audio Ports

Connector	Tip	Ring	Sleeve
Digital Input/Output	Out	In	GROUND
Headphone Output	L	R	GROUND
Line Output	L	R	GROUND
Line Input	L	R	GROUND
Microphone Input	L	R	GROUND

International Keyboard Support

This appendix provides information on selecting an international keyboard layout for the language of your choice on your Indigo² workstation.

International Keyboard Support

The Indigo² system uses a PC-compatible keyboard that does not support software identification for the varied international keyboard languages that Silicon Graphics offers.

Instead, you can select the keyboard layout from the System Maintenance menu. To do this, follow these steps:

1. After you've assembled the workstation, turn on the power.
 - Press the power switch on the front of the monitor to turn on your monitor.
 - Open the door on the front of the Indigo² by snapping it away from the top edge of the chassis and tipping it down, as shown in Figure B-1.

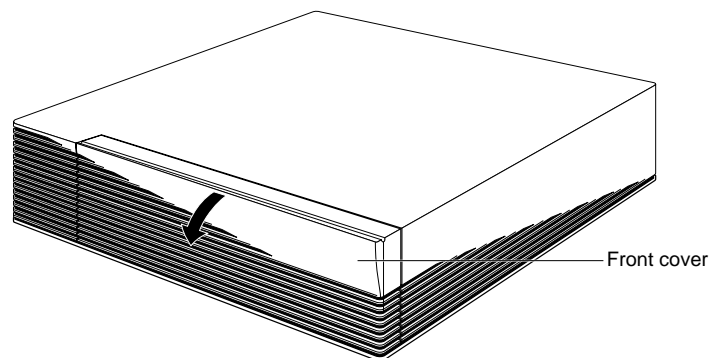

Figure B-1 Opening the Door on the Front of the Indigo² Workstation

- Press the power switch to turn on the system, as shown in Figure B-2.

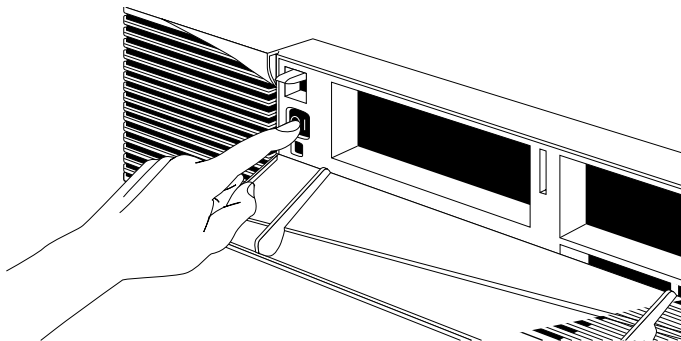

Figure B-2 Turning on the Indigo² Workstation

2. While the system is powering up, you see the notifier shown in Figure B-3 on your monitor screen.

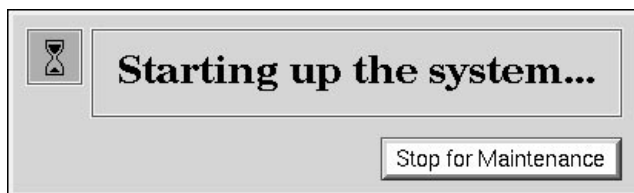

Figure B-3 System Startup Notifier

3. Click *Stop for Maintenance* to display the System Maintenance menu icons.
4. Click the Select Keyboard Layout icon.

The keyboard layout menu is displayed, as shown in Figure B-4.



Figure B-4 Keyboard Layout Form

5. Click the box next to the name that describes your keyboard, then click *Apply*.

Table B-1 lists the keyboard layout choices and their corresponding languages.

Table B-1 Keyboard Layout Language Choices

Keyboard Layout	Language
BE	Belgian
DE	German
de_CH	Swiss German
DK	Danish
ES	Spanish
FI	Finnish
FR	French
fr_CH	Swiss French
GB	Great Britain
IT	Italian
NO	Norwegian
PT	Portuguese
SE	Swedish
US	United States
Custom	Language you select

To test if the correct layout was selected, click the Command Monitor icon, and try typing some sample text, including special characters specific to your keyboard.

Glossary

account

See login account.

active window

The only window that recognizes input (activity) from the keyboard and mouse; only one window is active at a time.

address dial

See SCSI address dial.

administrator

See system administrator and network administrator.

back up

To copy a certain set of files and directories from your hard disk to a tape.

backup tape

A tape that contains a copy of the files and directories that are on your hard disk. A full backup tape contains a copy of all files and directories, including IRIX, that are on your hard disk.

baud rate

The speed (calculated as bits per second) at which the computer sends information to a serial device, such as a modem or terminal.

blanking panel

A piece of black plastic attached to the front plastic panel of the Indigo chassis that covers either the top or middle drive slot. You remove a blanking panel after you install a drive in the slot that it was covering.

boot

To start up the system by turning on the workstation and monitor; the system is fully booted when you see the `console login:` prompt or the login screen.

button

On a mouse, a button is a switch that you press with a finger. In a window on your screen, a button is a labelled rectangle that you click using the cursor and mouse.

CD-ROM disc (CD)

A flat metallic disk that contains information that you can view and copy onto your own hard disk; you cannot change or add to its information. CD-ROM is short for *compact-disc: read-only memory*.

CPU board

The printed circuit board within your workstation chassis that contains the central processing unit(s). When you open the front metal panel of the Indigo chassis, it is the board on the left.

card guides

Narrow metal tracks at the top and bottom of the chassis into which you slide printed circuit boards.

choose

To press the left mouse button to bring up a pop-up menu, move the cursor to highlight the command that you want to run, then release the button.

click

To hold the mouse still, then press and immediately release a mouse button.

configuration file

A system file that you change to customize the way your system behaves. Such files are sometimes referred to as customization files.

confidence test

A test that you run to make sure a particular device (such as the keyboard, mouse, or a drive) is set up and working properly.

connector

Hardware at the end of a cable that lets you fasten the cable to an outlet, port, or other connector.

console window

The window that appears as a stowed icon each time you log in; IRIX reports all status and error messages to this window.

current working directory

The directory within the file system in which you are currently located when you are working in a shell window.

cursor

The small red arrow or other shape on the screen that follows the movements of the mouse. It may change shape depending on its location on the screen.

DAT

Digital Audio Tape. The Silicon Graphics DAT drive can be used with both audio and digital media.

default printer

The printer to which the system directs a print request if you do not specify a printer when you make the request. You set the default printer using the Print Manager.

defaults

A set of behaviors that Silicon Graphics specifies on every system. You can later change these specifications, which range from how your screen looks to what type of drive you want to use to install new software.

diagnostics

A series of tests that check the hardware components of your system.

directory

A special file in the file system in which you store other directories and files.

disk use

The percentage of space on your disk that contains information.

disk resource

Any disk (hard, CD-ROM, or floppy) that you can access either because it is physically attached to your workstation with a cable, or because it is available over the network using NFS.

double-click

To hold the mouse still, then press and release it twice, very rapidly. When you double-click an icon, it opens into a window; when you double-click the *Window menu* button, the window closes.

drag

To press and hold down a mouse button, then move the mouse. This drags the cursor to move icons or to highlight menu items.

drive

A hardware device that lets you access information on various forms of media, such as hard and floppy disks, CD-ROM discs, and magnetic tapes.

drive address

See SCSI address.

external device

Any piece of hardware that is attached to the workstation with a cable.

export

To use NFS software to make all or part of your file system available to other users and systems on the network.

female connector

A connector that has indentations or holes into which you plug a male connector. An example of a female connector is an electrical wall outlet that accepts an electrical plug.

field

An area in a window in which you can type text.

file

A set of disk blocks in which you store information such as text, programs, or images that you created using an application.

file system

A hierarchy of directories and files. Directories contain other directories and files; files cannot contain directories. The *root* (/) directory is at the top of the hierarchy.

form

A window containing buttons that you must click and/or editable fields that you must fill in.

graphics board

The printed circuit board within your workstation that contains the graphics processors. When you open the front metal panel of the Indigo chassis, it is the board on the right.

grounded electrical outlet

An electrical wall outlet that accepts a plug with a grounding prong. In the U.S.A., all three-prong outlets are grounded.

handshake

The protocol that controls the flow of information between a workstation and a printer.

highlight

To change the color of an item on the screen by positioning the cursor over it (locate-highlight), or by positioning the cursor over it and pressing a mouse button.

home directory

The directory into which IRIX places you each time you log in. It is specified in your login account; you own this directory and, typically, all its contents.

host

Any system connected to the network.

hostname

The name that uniquely identifies each host (system) on the network.

Human Factors guidelines

A set of standards and suggestions for making your working environment more comfortable and healthy.

icon

A small picture that represents a stowed or closed file, directory, application, or IRIX process.

internal drive

A drive that fits inside the workstation and connects to an internal port; it is never connected with a cable to a visible external port. An internal drive is occasionally referred to as a front-loading drive.

IP address

A number that uniquely identifies each host (system) on a TCP/IP network.

IRIS

A graphics workstation manufactured by Silicon Graphics, Inc.

IRIX

The Silicon Graphics version of the UNIX operating system. *See also* system software.

jot

A mouse and window based text editor that is included as part of the IRIX operating system.

KB (kilobyte)

A standard unit for measuring the information storage capacity of disks and memory (RAM and ROM); 1024 bytes make one kilobyte, in most uses.

LED

Light Emitting Diode. A light on a piece of hardware that indicates status or error conditions.

launch

To start up an application, often by double-clicking an icon.

local workstation

The physical workstation whose keyboard and mouse you are using, all hardware that is connected to that workstation, and all software that resides on that hardware or its removable media.

lockbar

A long piece of metal with a lock icon on the end that you attach to the chassis. It allows you to secure the workstation with a lock and locking cable.

log in

To give the system your login name so you can start a session on the workstation.

log out

To end a session on the workstation.

login account

A database of information about each user that, at the minimum, consists of the login name, user ID, and home directory.

login name

A name that uniquely identifies a user to the system.

login screen

The window that you see after powering on the system, before you can access files and directories. The window contains one icon for each login account on the system.

MB (megabyte)

A standard unit for measuring the information storage capacity of disks and memory (RAM and ROM); 1024 kilobytes make one megabyte, in most uses.

male connector

A connector that has raised edges, pins, or other protruding parts that you plug into a female connector. An example of a male connector is an electrical plug that you plug into a wall outlet.

man page

An online document that describes how to use a particular IRIX command.

menu

A list of operations or commands that the workstation can carry out on various objects on the screen.

monitor

A hardware device that displays the images, windows, and text with which you interact to use the system. It is also called a video display terminal (VDT).

monitor video cable

The cable that connects the monitor to the workstation to transmit video signals. It is thick and beige, with large connectors on both ends.

monitor power cable

The cable that connects the monitor to the workstation to provide power to the monitor. It is thick and beige, with a male connector on one end and a female connector on the other.

mount point

The directory on your workstation from which you access information that is stored on a local or remote disk resource.

mount

To make a file system that is stored on a local or remote disk resource accessible from a specific directory on your workstation.

mouse

A hardware device that you use to communicate with windows and icons. You move the mouse to move the cursor on the screen, and you press its buttons to initiate operations.

mouse pad

For an optical mouse, this is the rectangular, metallic surface that reads the movements of the mouse. For a mechanical mouse, this is a clean, soft, rectangular surface that makes the mouse's track ball roll efficiently.

network

A group of computers and other devices (such as printers) that can all communicate with each other electronically to transfer and share information.

network administrator

The individual(s) responsible for setting up, maintaining, and troubleshooting the network, and for supplying setup information to system administrators of each system.

notifier

A form that appears when the system requires you to confirm an operation that you just requested, or when an error occurs.

open

To double-click an icon, or to select an icon, then choose "Open" from a menu in order to display a window that contains the information that the icon represents.

option drive

Any internal drive other than the system disk. Option drives include floppy disk drives, secondary hard disk drives, or DAT drives.

outlets

Openings in the hardware to which you attach connectors to make an electrical connection.

PROM monitor

The interface that you use to communicate with the system after it is powered up, but before it is booted up and running IRIX.

Printer Manager

A tool that you access through either the System toolchest or the System Manager. You use it to set up printer software and monitor jobs that you send to the printer.

parallel port

An outlet on the workstation to which you connect external printers and similar devices.

password

A combination of letters and/or numbers that only you know; it is an optional element of your login account. If you specify a password for your account, you must type it after you type your login name before the system will let you access files and directories.

pathname

The list of directories that leads you from the *root* (/) directory to a specific file or directory in the file system.

peripheral

A hardware device that adds more functionality to the basic workstation, such as a tape drive. *See also* external devices and internal drives.

port

An outlet to which you attach cable connectors.

power-on diagnostics

A series of tests that automatically check the hardware components of your system each time you turn it on.

power cable

The cable that connects the workstation to a grounded electrical outlet.

power down

To turn off the power switches on the workstation chassis and the monitor.

power supply

The piece of hardware within the Indigo chassis that directs power from an electrical outlet to the chassis, the monitor, and internal SCSI devices. It also contains the power switch, reset button, and fan.

power up

To turn on the workstation and monitor by pressing their power switches.

prompt

A character or word that the system displays in an IRIX shell; it indicates that the system is ready to accept commands. The default prompt for regular user accounts is %; the default prompt for the root account is #.

quit

To stop running an application.

remote workstation, drive, disk, file system, or printer

A hardware device, or the information or media it contains, that you can access across the network; they are not physically connected to your workstation.

reset button

A physical button on the workstation that you can press, which cuts off power to the workstation, and then immediately restores it. You should never press this button while IRIX is running, unless all attempts fail to shut down the system using software. *See also* shut down.

restore (files)

To copy files that once resided on your hard disk from another disk or a tape back onto your hard disk.

root account

The standard IRIX login account reserved for use by the system administrator. This account's home directory is the *root* (/) directory of the filesystem; the user of the *root* account has full access to the entire filesystem (that is, can change and delete any file or directory). The user of this account is sometimes referred to as the *superuser*.

root (/) directory

The directory at the top of the file system hierarchy.

SCSI

Small Computer System Interface (pronounced "scuzzy"). SCSI is a high speed input/output specification for small computers. Indigo² is SCSI-2 compliant and supports two fast/narrow/single-ended SCSI buses, each capable of transferring data at 10 MB per second.

SCSI address

A number from one to seven that uniquely identifies a SCSI device to a system. No two SCSI devices that are physically connected to the same SCSI bus can have the same SCSI address.

SCSI address dial

A small plastic dial connected to some Silicon Graphics external SCSI devices. You click on its small buttons to select a SCSI address for a new SCSI device.

SCSI bus length

The combined length of all internal and external SCSI cables in a system for each SCSI bus.

SCSI cable

A cable that connects a SCSI device to a SCSI port on a workstation.

SCSI device

A hardware device that uses the SCSI protocol to communicate with the system. Hard disk and floppy disks, CD-ROM discs, and tape drives are all SCSI devices. *See also* SCSI.

SCSI terminator

An electronics device, often an external plug, that is required at the end of each SCSI bus. Indigo² uses active terminators.

SIMM

A small printed circuit board with DRAM (Dynamic Random Access Memory) chips.

SIMM removal tool

An L-shaped metal tool that you use to loosen SIMMs installed in the SIMM sockets.

SIMM socket

A long, thin, female connector located on the CPU board into which you insert a SIMM.

System Manager

A set of tools that the administrator uses to set up and manage the Silicon Graphics workstation. You access the System Manager through the System toolchest.

System toolchest

The toolchest in the upper left-hand corner of the screen, labelled "System." You start system tools, such as System Manager, using this menu.

screen

The portion of the monitor that displays information.

select

To position the cursor over an icon, then click the (left) mouse button. Once an icon is selected, it is the object of whatever operation you select from a menu.

serial device

Any hardware device that requires a serial cable connection to communicate with the workstation.

serial port

An outlet on the workstation to which you connect external serial devices.

server

A system that other systems on the network access to use its disk space, software, or services.

shell

A window into which you type IRIX commands.

shielded cable

A cable with a protective covering that reduces the possibility of interference with radio, television, and other devices.

shut down

To safely close all files, log out, and bring the workstation to a state where you can safely power it down. You choose "System Shutdown" from the System toolchest menu to do this.

software option

Any software product that you buy from Silicon Graphics other than the standard system software that comes on your system disk.

stand-alone workstation

A workstation that is not connected to a network.

static electricity

Whenever your body comes in physical contact with metal parts (including printed circuit boards) of computer equipment there is the potential for you to feel an electrical shock (electro-static discharge, or ESD) which could damage the equipment. To prevent this, you must always wear a wrist strap when working with internal parts of a workstation.

superuser

A user with root privileges. You become a superuser by logging in as root, by typing `su` at the shell prompt, or by running programs set up to run as root. *See also* system administrator.

system

All the hardware and software that makes up the workstation.

system administration

The tasks associated with setting up, maintaining, and troubleshooting a networked or stand-alone system.

system administrator

The individual responsible for setting up, maintaining, and troubleshooting a system. The system administrator uses the *root* login account to perform most administrative tasks.

system crash

When the IRIX operating system fails and the system will not accept any keyboard or mouse input.

system disk

The physical disk that contains the standard IRIX operating system software (the software that makes your workstation run).

system software

The standard IRIX operating system software and Silicon Graphics tools. These come on the system disk and on the CD that you use in the event of a system crash.

TCP/IP

The standard networking software that is included in the system software.

thumbscrew

The ridged knob attached to a screw in a cable connector. You turn it to secure the connector to an outlet.

upgrade

Hardware that you add to the basic workstation to increase performance, such as additional memory (SIMMs) or faster graphics boards.

unmount

To make a file system that is accessible from a specific directory on your workstation temporarily inaccessible.

user ID (UID)

A number that uniquely identifies a user to the system.

window

A portion of the screen that you can manipulate that contains text or graphics.

workstation

The physical hardware that contains the CPU and graphics boards, a system disk, and a power supply. You connect it to a monitor, keyboard, and mouse to configure a working system. The workstation is also sometimes referred to as the chassis.

wrist strap

A coiled cable with a loop at one end and an alligator clip at the other. You place the loop around your wrist and fasten the clip to a metal part of the workstation whenever you work with internal components of the workstation. This prevents electrical shocks to yourself and the components. *See also* static electricity.

Index

A

addresses for external drives, 91
audio ports cable pinouts, 233

B

backups, 145, 148, 208
bezel, removing front, 16
bezel, replacing front, 19
boards
 installing, 69
 removing, 75

C

cable pinout assignments, 223
 audio ports, 233
 Ethernet 10-BASE T port, 227
 Ethernet AUI port, 228
 keyboard port, 229
 mouse port, 230
 parallel port, 225
 SCSI port, 231
 serial ports, 224
cables
 dial and button boxes, 101
 monitor cable, 22
 serial cables, 101
 serial power cables, 101

 standard Ethernet cable, 26
 system power cables, 28
 using shielded, 218
confidence tests, 137
 dial and button boxes, 139
 digitizer tablets, 139
 Genlock options, 139
 keyboards, 142
 monitors, 143
 mouse, 144
 tape drives, 144
Console window, 37
cover (front), opening, 39
cover, top
 removing, 51
 replacing, 54
CPU baseboard
 replacing, 157
CPU boards
 error messages, 131
CPU module
 replacing, 157

D

diagnostic tests, 133
 See also confidence tests
 power-on, 30, 31, 126
dial and button boxes, 100, 101
 confidence tests, 139

dials boxes, 100
digitizer tablets, 100
 confidence tests, 139
disk drives. *See* drives
disks
 ejecting floppy, 89
 formatting floppy, 89
documentation, 5
drive addresses, for external drives, 91
drives
 installing, 83
 installing external, 90
 removing, 90
 testing new, 88

E

EISA boards
 installing, 69
 removing, 75
error messages
 CPU boards, 131
 electronics modules, 137
 graphics boards, 130
 memory, 128, 184
<Esc> key, to perform system maintenance, 146
Ethernet
 attaching to Ethernet 10-BASE T, 27
 attaching to standard Ethernet, 26
Ethernet 10-BASE T cable, 27
Ethernet 10-BASE T port cable pinouts, 227
Ethernet AUI port cable pinouts, 228
external drives
 checking drive address, 91
 installing, 90
 replacing, 202
EZsetup, creating login, 32

F

floppy disk drives, 89
floppy disks
 ejecting, 89
 formatting, 89
format command
 tape drives, 89
front cover, opening, 39

G

Genlock options, 139
graphics board
 error messages, 130
 installing, 69
 replacing, 157
graphics tests, 136

H

hardware
 maintenance, 207
Help, 5
help
 service and support, 152

I

InSight documentation, 5
installing
 EISA boards, 69
 Ethernet 10-BASE T, 27
 external drives, 90
 internal drives, 83
 memory, 49
 serial devices, 100

- software subsystems, 115
- standard Ethernet, 26
- system disk, 17
- system power cable, 28
- workstation, 14

interference to radios and televisions, 217

internal drives

- installing, 83
- replacing, 157
- turning on software, 88

international keyboards, 237

IRIX shell, 37

K

keyboard

- confidence tests, 142
- replacing, 202
- troubleshooting, 133

keyboard port cable pinouts, 229

keyboards

- international, 237

L

limited user warranty, 219

locking up the workstation, 30, 44

login account

- setting up, 32

M

maintenance, 207

manuals, 5

memory

- checking after installation, 55

- checking and replacing SIMMs, 157
- indicator of problems, 128
- installing, 49
- removing SIMMs, 57

monitors

- confidence tests, 143
- installing, 22

monitor video cables, 22

mouse

- confidence test, 144
- replacing, 202
- shortcuts with, 35
- troubleshooting, 133

mouse port cable pinouts, 230

O

online

- documentation, 5

opening front cover, 39

orange LED, 30, 128, 130

P

parallel port cable pinouts, 225

parts

- replacement, 156

password, disabling system maintenance, 150

peripherals

- See also* drives
- confidence tests, 137
- error messages, 137
- internal drives, 83
- serial devices, 100

power cables

- SCSI devices, 97
- serial devices, 101

- powering down the workstation, 39
- powering up the workstation, 30
- power-on diagnostics, 30, 126
- power supply
 - replacing, 157
- power switch, 39

R

- radio interference, 217
- recovery from system crashes, 145
- removing
 - drives, 90
 - EISA boards, 75
 - front bezel, 16
 - memory, 57
 - software subsystems, 115
 - top cover, 51
- replacement parts, 156
- replacing
 - CPU baseboard, 157
 - CPU module, 157
 - external drives, 202
 - external parts, 202
 - front bezel, 19
 - graphics board, 157
 - internal drives, 157
 - internal parts, 157
 - keyboard, 202
 - mouse, 202
 - power supply, 157
 - SIMMs, 157
 - top cover, 54

S

- safety, 207

- screens
 - looking strange, 132
- SCSI
 - addresses for drives, 91
 - connectors, 96
 - port cable pinouts, 231
- serial
 - cable pinouts for ports, 224
 - cables, 101
 - connectors, 100
 - installing devices, 100
- service information, 152
- shielded cables, 218
- shutting down the workstation, 39, 134
- Silicon Graphics, Inc.
 - replacement parts, 156
 - service and support, 152
- site selection for the workstation, 12
- software
 - installation manual, 5
 - internal drives, 88
 - maintenance, 208
 - on CDs, 14
 - serial devices, 102
 - system crashes, 145
- subsystems
 - installing and removing, 115
- support information, 152
- system
 - maintenance, 146
 - power cables, 28
 - recovering from a crash, 145
- system disk, installing, 17
- System Maintenance Menu, 146
- System toolchest
 - to shut down the workstation, 41
- system voltage requirements, 28

T

- tape drives
 - confidence tests, 144
- television interference, 217
- Toolchest, to shut down workstation, 41
- top cover
 - removing, 51
 - replacing, 54
- troubleshooting
 - checking and replacing memory, 157
 - confidence tests, 137
 - diagnostic tests, 133
 - dial and button boxes, digitizer tablets and Genlock options, 139
 - keyboards, confidence tests, 142
 - monitors, confidence tests, 143
 - mouse, confidence tests, 144
 - power-on tests, 126
 - recovery from system crashes, 145
 - replacement parts, 156
 - replacing CPU base, 157
 - replacing CPU module, 157
 - replacing external drives, 202
 - replacing graphics board, 157
 - replacing internal drives, 157
 - replacing keyboard, 202
 - replacing mouse, 202
 - replacing power supply, 157
 - service and support, 152
 - tape drives, confidence tests, 144
- turning off the workstation, 39
- turning on the workstation, 30

V

- video cables, 22
- voltage requirements, 28

W

- warranty, 219
- workstations
 - checking your shipment, 12
 - installing, 14
 - installing memory, 49
 - locking up, 30, 44
 - powering up, 30
 - radio and television interference caused by, 217
 - service and support information, 152
 - shutting down, 39
 - site selection for, 12
 - turning off, 39
 - turning on, 30
- wrist strap, 159

Part Request Form

RMA#
Closed _/_/_/

Company Name
Street Address
City/State/Zip Code
Contact
Phone
Fax
Purchase Order Number

Call ID #	Model Type	Warranty	System Serial # (as found on back panel)
		Y N	

System Configuration Information:

System S/W Version _____	Type of failure: <input type="checkbox"/> Solid <input type="checkbox"/> Intermittent	Peripherals: <input type="checkbox"/> DAT <input type="checkbox"/> CD-ROM <input type="checkbox"/> Floptical <input type="checkbox"/> Other_____	Voltage: <input type="checkbox"/> 110 <input type="checkbox"/> 220	Disk (MB/GB) _____	Memory (MB): _____
-----------------------------	---	--	--	-----------------------	-----------------------

Problem description (please describe symptoms, error messages and actions taken):

Date _____

Failed part information:

Part Number:	Revision:	Date:
□□□□ - □□□□□□ - □□□□	□□□□	_/_/_/
□□□□ - □□□□□□ - □□□□	□□□□	_/_/_/
□□□□ - □□□□□□ - □□□□	□□□□	_/_/_/
□□□□□□□□	□□□□	_/_/_/
□□□□□□□□	□□□□	_/_/_/
□□□□□□□□	□□□□	_/_/_/

For fast service, please complete this form in its entirety!

Tell Us About This Manual

As a user of Silicon Graphics products, you can help us to better understand your needs and to improve the quality of our documentation.

Any information that you provide will be useful. Here is a list of suggested topics:

- General impression of the document
- Omission of material that you expected to find
- Technical errors
- Relevance of the material to the job you had to do
- Quality of the printing and binding

Please send the title and part number of the document with your comments. The part number for this document is 007-9096-050.

Thank you!

Three Ways to Reach Us

- To send your comments by **electronic mail**, use either of these addresses:
 - On the Internet: techpubs@sgi.com
 - For UUCP mail (through any backbone site): *[your_site]!sgi!techpubs*
- To **fax** your comments (or annotated copies of manual pages), use this fax number: 650-932-0801
- To send your comments by **traditional mail**, use this address:

Technical Publications
Silicon Graphics, Inc.
2011 North Shoreline Boulevard, M/S 535
Mountain View, California 94043-1389

