

DIGITAL TLZ09/TLZ10 Cassette Tape  
Drive and TLZ9L Autoloader

---

Owner's Manual

Part Number: EK-TLZXX-OM. A01

**August 1997**

---

**August 1997**

Digital Equipment Corporation makes no representations that the use of its products in the manner described in this publication will not infringe on existing or future patent rights, nor do the descriptions contained in this publication imply the granting of licenses to make, use, or sell equipment or software in accordance with the description.

© Digital Equipment Corporation 1997. All rights reserved.

The following FCC and VCCI notices apply to the tabletop devices. Embedded versions will be covered by similar notices in the documentation for the system or storage enclosure in which they reside.

**FCC NOTICE:** The equipment described in this manual has been certified to comply with the limits for a Class B computing device, pursuant to Subpart J of Part 15 of FCC Rules. Only peripherals (computer input/output devices, terminals, printers, et cetera) certified to comply with the Class B limits may be attached to this computer. Operation with noncertified peripherals may result in interference to radio and television reception. This equipment generates and uses radio frequency energy and if not installed and used properly, that is, in strict accordance with the manufacturer's instructions, may cause interference to radio and television reception. It has been type tested and found to comply with the limits for a Class B computing device in accordance with the specifications in Subpart J of Part 15 of FCC Rules, which are designed to provide reasonable protection against such interference in a residential installation. However, there is no guarantee that interference will not occur in a particular installation. If this equipment does cause interference to radio or television reception, which can be determined by turning the equipment off and on, the user is encouraged to try to correct the interference by one or more of the following measures:

- Reorient the receiving antenna.
- Move the computer away from the receiver.
- Plug the computer into a different outlet so computer and receiver are on different branch circuits.

The tabletop versions require a shielded interface cable in order to comply with FCC emissions limits.

The following are trademarks of Digital Equipment Corporation: DECdirect, DECmailer, DECservice, DECstation, DIGITAL, OpenVMS, Q-bus, SERVICenter, StorageWorks, ULTRIX, VAXstation, VMS, and the DIGITAL logo.

Novell and NetWare are registered trademarks of Novell, Inc.

Microsoft is a registered trademark and Windows NT is a trademark of Microsoft Corporation.

Sony is a registered trademark of Sony Corporation.

Sun and Solaris are registered trademarks and SunOS is a trademark of Sun Microsystems, Inc.

IBM and AIX are registered trademarks and RS/6000 is a trademark of International Business Machines Corporation.

Hewlett-Packard and HP-UX are registered trademarks of Hewlett-Packard Company.

Für Bundesrepublik Deutschland

For Federal Republic of Germany

Pour la République fédéral d'Allemagne

#### BESCHEINIGUNG DES HERSTELLERS/IMPORTEURS

Dieses Gerät ist in Übereinstimmung mit den Bestimmungen der BMPT Vfg.243/1991 und Vfg.46/1992 in Verbindung mit EN55022:1987 (DIN VDE 0878-3:11.89), oder Vfg.1046/1984 mit Vfg. 483/1986, funkentstört. Es trägt als Nachweis der EMV-Konformität entweder eine Konformitätskennzeichnung oder das VDE-Funkschutzzeichen.

Der vorschriftsmäßige Betrieb mancher Geräte (z.B. Meßsender) kann allerdings gewissen Einschränkungen unterliegen. Beachten Sie deshalb die unten aufgeführten Hinweise.

Für Geräte die nicht mit dem VDE-Funkschutzzeichen versehen sind wurde dem Bundesamt für Zulassungen in der Telekommunikation (BZT) das Inverkehrbringen dieses Gerätes angezeigt und die Berechtigung zur Überprüfung der Serie auf Einhaltung der Bestimmungen eingeräumt.

#### Betreiberhinweis

Wir sind verpflichtet, Sie auf folgende Fakten hinzuweisen (BMPT-Amtsblattverfügung 243/91 bzw. 1046/84 §2, Abschnitt 5):

Dieses Gerät wurde funktechnisch sorgfältig entstört und geprüft. Wird dieses Gerät innerhalb einer Anlage zusammen mit anderen Geräten betrieben, muß bei Inanspruchnahme der "Allgemeinen Betriebsgenehmigung" nach BMPT-AmtsblVfg. 243/91 bzw. 1046/84 die gesamte Anlage den unter §2, Abschnitt 1, genannten Voraussetzungen entsprechen.

#### Externe Datenkabel

Sollte ein Austausch der von Digital spezifizierten Datenkabel nötig werden, muß der Betreiber für eine einwandfreie Funkentstörung sicherstellen, daß Austausch kabel im Aufbau und Abschirmqualität dem Digital Originalkabel entsprechen.

**VCCI:**

この装置は、第二種情報処理装置（住宅地域又はその隣接した地域において使用されるべき情報装置）で住宅地域での電波障害防止を目的とした情報処理装置等電波障害自主規制協会（VCCI）基準に適合しております。

しかし、本装置をラジオ、テレビジョン受信機に近接してご使用になると、受信障害の原因となることがあります。

取扱説明書に従って正しい取り扱いをして下さい。

---

# Table of Contents

## 1 TLZ09/9L and TLZ10 Cassette Tape Device Product Description

1.1 Overview .....	1-1
1.1.1 System Support .....	1-2
1.2 Design Features.....	1-2
1.2.1 What is Digital Audio Tape (DAT)?.....	1-2
1.2.2 What is Digital Data Storage (DDS)? .....	1-2
1.2.3 What is the Media Recognition System (MRS)?.....	1-3
1.3 Drive/Loader Models .....	1-3
1.3.1 Checking Your Shipment for Model TLZ09/TLZ10 Tabletop Drives .....	1-8
1.3.2 Checking your Shipment for Model TLZ9L-DA/DB .....	1-8
1.3.3 Ordering Additional Cassettes .....	1-9
1.3.4 Visiting Web Site for the Latest Information .....	1-9

## 2 Installing the Tabletop Drive or Autoloader

2.1 General .....	2-1
2.2 Shut Down, Halt, and Power Off the System .....	2-1
2.3 Selecting the SCSI Address.....	2-2
2.4 Connecting a SCSI Signal Cable --- Device to System .....	2-3
2.5 Adding Another Tabletop Device --- Device to Device .....	2-4
2.6 Connecting the Power Cable .....	2-4

## 3 Installing the 3.5-Inch or 5.25-Inch Cassette Tape Drive

3.1 General .....	3-1
3.2 Shut Down, Halt, and Power Off the System .....	3-1
3.3 Selecting the Jumper and Switch Configuration for the Drive .....	3-1
3.3.1 SCSI ID Address Jumpers .....	3-2

3.3.2 Other Optional Jumper Settings.....	3-4
3.3.3 Drive Switch Settings.....	3-4
3.4 Connecting a SCSI Signal Cable --- Drive to System.....	3-6
3.5 Connecting the Power Cable and Mounting .....	3-6

## 4 Verifying TLZ09/TLZ10 Cassette Tape Drive Installation

4.1 General.....	4-1
4.1.1 Execute POST.....	4-1

## 5 Using the TLZ09/TLZ10 Cassette Tape Drive

5.1 General.....	5-1
5.2 Power Switch.....	5-1
5.3 Unload Button .....	5-1
5.4 Tape Drive LEDs.....	5-2
5.4.1 Status LED.....	5-2
5.4.2 Tape LED .....	5-2
5.4.3 Busy LED .....	5-2
5.5 Using the Cassette Tape.....	5-5
5.5.1 Proper Handling of Cassette Tapes.....	5-5
5.5.2 Setting the Write-Protect Tab on the Cassette Tape.....	5-6
5.5.3 Inserting a Cassette Tape into the Drive .....	5-7

## 6 Preventive Maintenance and Problem Solving

6.1 Introduction .....	6-1
6.2 Cleaning the Heads.....	6-1
6.3 Problem Solving .....	6-3
6.3.1 System-Based Diagnostics .....	6-4
6.4 Service Offerings.....	6-4

## 7 Using the TLZ9L Cassette Tape Autoloader

7.1 Overview .....	7-1
7.2 LED Indicators .....	7-2
7.3 LCD Panel .....	7-6
7.3.1 Warning Indicator .....	7-7
7.3.2 Write Protect Indicator.....	7-8
7.3.3 Error Indicator .....	7-9
7.3.4 7-Segment Numeric Display .....	7-9
7.3.5 Cartridge Number Indicators .....	7-10

7.4 TLZ9L Operation.....	7-10
7.4.1 Automatic Operations.....	7-10
7.4.2 Manual Operations .....	7-11
7.4.3 Magazine Operations.....	7-11
7.4.3.1 Eight Cartridge Mode .....	7-11
7.4.3.2 Seven Cartridge Mode .....	7-12
7.4.3.3 Single Cartridge Mode.....	7-13
7.4.3.4 Loading Cartridges Into the Magazine .....	7-14
7.4.3.5 Loading the Magazine Into the TLZ9L.....	7-15
7.4.3.6 Ejecting the Magazine .....	7-16
7.4.3.7 Unloading Cartridges From the Magazine.....	7-17
7.4.3.8 Autoload Function .....	7-18
7.5 Switch Settings .....	7-18
7.5.1 Switchpack Settings .....	7-18
7.5.2 SCSI ID Select Switch (TLZ9L-DA/DB Only).....	7-19
7.6 Cleaning Requirements .....	7-19

## A Cassette Tape Drive and Autoloader Specifications

## B Product Notes for DIGITAL UNIX, OpenVMS, and Windows NT

DIGITAL UNIX TLZ09/TLZ10 Compression and Noncompression Modes .....	B-1
DIGITAL UNIX DUMP Utility .....	B-1
OpenVMS TLZ09/TLZ10 Compression and Noncompression Modes.....	B-2
Windows NT TLZ09/TLZ10 Compression and Noncompression Modes.....	B-2
DIGITAL Operating System Support.....	B-3

## C Product Notes for Non-DIGITAL Platforms

Product Notes for Novell NetWare and Microsoft Windows NT .....	C-1
Host SCSI Interface .....	C-1
Product Notes for Sun .....	C-3
General Information.....	C-3
Modifications Required for SunOS 4.1.x.....	C-4
Installation Procedure.....	C-4
System Modification .....	C-4
Rebuilding of Kernel.....	C-5
Installation of Tape Drive.....	C-6
Rebooting of System .....	C-6
Testing the Tape Drive.....	C-7
Verification.....	C-7

Dump Parameters for the Tape Drive .....	C-7
Modifications Required for Solaris 2.3 (or later) .....	C-8
Installation Procedure .....	C-8
System Modification .....	C-8
System Shutdown .....	C-10
Installation of the Tape Drive .....	C-10
Rebooting of System .....	C-11
Test .....	C-12
Verification .....	C-12
Dump Parameters for the Tape Drive .....	C-12
Product Notes for IBM RS/6000 .....	C-13
Modifications Required to Operate the Tape Drive with AIX 3.2.5 (or later) .....	C-13
Installing the Tape Drive Using the SMIT Command .....	C-13
Installing the Tape Drive Using Command-Line Interface .....	C-14
Using the Tape Drive to Install AIX .....	C-15
Product Notes for Hewlett-Packard .....	C-16
General Information .....	C-16
Modifications Required .....	C-16
Installation Procedure .....	C-17
Installation of Tape Drive .....	C-17
System Modification .....	C-17
System Device Files .....	C-17
HP-UX 9.05 .....	C-18
HP-UX 10.x .....	C-19
Testing the Tape Drive .....	C-20
Verification .....	C-20
Dump Parameters for the Tape Drive .....	C-21

## Index

## Figures

Figure 1-1 Model TLZ09-DA/DB and DS-TLZ10-DB (Tabletop) .....	1-4
Figure 1-2 Model TLZ09-AA/AB and TLZ10-AB (3.5-inch Chassis) .....	1-5
Figure 1-3 Model TLZ09-BA/BB and TLZ10-BB (5.25-inch Chassis) .....	1-6
Figure 1-4 TLZ09/TLZ10 Chassis - Underside with Switch Pack .....	1-7
Figure 3-1 Configuration Jumper Block .....	3-3
Figure 3-2 Drive Switch Settings .....	3-5
Figure 5-1 TLZ09/TLZ10 Cassette Tape .....	5-6
Figure 7-1 Model TLZ9L-AA (Front and Rear View) .....	7-3



Figure 7-2 Model TLZ9L-AA Bottom View .....	7-4
Figure 7-3 Model TLZ9L-DA/DB (Front and Rear View).....	7-5
Figure 7-4 TLZ9L LCD Panel.....	7-6
Figure 7-5 TLZ9L Cassette Magazine.....	7-8
Figure 7-6 Eight Cartridge Mode .....	7-12
Figure 7-7 Seven Cartridge Mode .....	7-12
Figure 7-8 Single Cartridge Mode.....	7-13
Figure 7-9 Loading Cartridges Into the Magazine .....	7-14
Figure 7-10 Loading the Magazine Into the TLZ9L-DA/DB .....	7-15
Figure 7-11 Unloading Cartridges From the Magazine.....	7-17

## Tables

Table 3-1 SCSI ID Jumper Settings (0=Removed, 1=Installed).....	3-3
Table 3-2 Drive Switch Default Settings .....	3-5
Table 5-1 TLZ09/TLZ10 LED Status.....	5-2
Table 6-1 Problem Solving .....	6-3
Table 7-1 BUSY and TAPE LEDs Status.....	7-2
Table 7-2 Warning Indications.....	7-7
Table 7-3 Error Indications .....	7-9
Table 7-4 Autoloader Switchpack Settings.....	7-18
Table A-1 TLZ09/TLZ10 Cassette Tape Drive Specifications .....	A-1
Table A-2 TLZ09/TLZ10 Cassette Tape Drive Dimensions .....	A-3
Table A-3 TLZ09/TLZ10 Tabletop Noise Declaration.....	A-3
Table A-4 TLZ9L Cassette Tape Autoloader Specifications .....	A-4
Table A-5 TLZ9L Cassette Tape Autoloader Dimensions.....	A-5
Table A-6 TLZ9L-DA/DB Noise Declaration .....	A-6
Table B-1 Operating System Support.....	B-3



---

# TLZ09/9L and TLZ10 Cassette Tape Device Product Description

## 1.1 Overview

The TLZ09/9L and TLZ10 Digital Audio Tape (DAT) devices provide you with high capacity, off-line data storage. Depending on the 4 mm data cassette tape used, these units can typically store the following amounts of data on each tape:

<b>Tape Type</b> (NOTES 1 and 2)	<b>No Compression</b>	<b>Compression</b>
TLZ04-CA (60 m, DDS-1)	1.3 GB	2.6 GB (see Note 3.)
TLZ06-CA (90 m, DDS-1)	2.0 GB	4.0 GB (see Note 3.)
TLZ07-CA (120 m, DDS-2)	4.0 GB	8.0 GB (see Note 3.)
TLZ10-CA (125 m, DDS-3)	12.0 GB	24.0 GB (see Notes 3 and 4.)

---

### Note

---

1. The TLZ09/9L and TLZ10 are compatible with 60 m cassette tapes written on the TLZ04 in the noncompressed mode only.
  2. The TLZ09/9L and TLZ10 are compatible with the TLZ06/6L using 60 m and 90 m tapes only, and with the TLZ07/7L using 60 m, 90 m, and 120 m tapes.
  3. The compression measurements are typical for a 2-to-1 data compression ratio, but the actual ratio is dependent on the data.
  4. DDS-3 media is supported only by the TLZ10.
-

## TLZ09/9L and TLZ10 Cassette Tape Device Product Description

The maximum time to back up (read or write) on a TLZ09/9L or TLZ10 cassette tape in a continual (streaming) mode is system dependent. The efficient use of streaming mode is determined by your operating system. Please refer to your system software documentation. See Appendix A for typical transfer rates.

### 1.1.1 System Support

As of this printing, the TLZ09/9L and TLZ10 devices are supported by a variety of DIGITAL systems. Consult your DIGITAL Sales Support representative for a list of supported systems. Your particular system must have an available standard SCSI (Small Computer System Interconnect) port in order to connect these devices.

## 1.2 Design Features

The TLZ09/9L and TLZ10 cassette tape devices use state of the art technology. Their design incorporates the Digital Data Storage (DDS) recording format and Digital Audio Tape (DAT) recording technologies. The TLZ09/9L is designed to provide a transfer rate that is twice that of standard DDS-2 DAT drives while still maintaining full DDS compatibility. The TLZ10 design provides the highest DDS-3 transfer rate available in the industry, while providing full backward compatibility to DDS-1.

### 1.2.1 What is Digital Audio Tape (DAT)?

DAT technology provides a high recording density with a very low error rate through the helical scan recording method. With this method of recording, both the tape and the recording head move simultaneously. The read and write heads are located on a rapidly rotating cylinder, or drum that is tilted at an angle in relation to the vertical axis of the tape. This causes the tracks to be recorded diagonally across the tape, resulting in an extremely high recording density, far higher than what is achievable with stationary-head devices.

### 1.2.2 What is Digital Data Storage (DDS)?

DDS uses a recording format that supports the use of digital audio tape for computer applications. The objectives of DDS are to maximize storage capacity and performance, facilitate data interchange, and provide very fast random access. In addition, this format has three levels of error correction, which ensures high data integrity. The DDS-DC format, which is a superset of the basic DDS DAT format, allows you to back up 8 gigabytes of data in approximately 1.5 hours minimum with no operator intervention, assuming 2:1 compression ratio with the TLZ09/9L. The fast transfer rate of the TLZ10 reduces the time to backup 8 gigabytes to under 1 hour, assuming the same 2:1 compression ratio.

## TLZ09/9L and TLZ10 Cassette Tape Device Product Description

---

### Note

---

Use of non-DDS media may result in degraded drive performance and is not recommended by Digital Equipment Corporation.

---

### 1.2.3 What is the Media Recognition System (MRS)?

MRS refers to a series of alternate opaque and clear stripes at the beginning of a tape. This striping is used to classify the media as data grade rather than audio grade media. Use of MRS helps to ensure that only data grade tapes are used in computer applications. All 120-meter and 125-meter cartridges support MRS. Shorter media are available in both MRS and non-MRS types.

## 1.3 Drive/Loader Models

The drives are available in several configurations:

- Model TLZ09-DA/DB and DS-TLZ10-DB (tabletop) --- a compact external unit with a built-in power supply and fan (see Figure 1-1).
- Model TLZ09-AA/AB and TLZ10-AB--- a 3 1/2-inch, half-height drive that mounts internally (see Figure 1-2 and Figure 1-4).
- Model TLZ09-BA/BB and TLZ10-BB --- a 3 1/2-inch drive in a 5 1/4-inch, half-height form factor allowing the drive to be mounted internally (see Figure 1-3 and Figure 1-4).
- Model TLZ09-VA and DS-TLZ10-VA--- a TLZ09-AA or TLZ10-AB mounted in a 3 1/2-inch StorageWorks SBB.
- Model TLZ09-AX --- a field spare unit that is configurable to an -AA, -AB, -BA, or -BB model. Includes bezel and rail installation procedures.
- Model TLZ10-AX --- a field spare unit that is configured as a -BB model, but can be reconfigured to satisfy installations needing a 3.5 in. white bezel or a 5.25 in. gray bezel. Includes bezels and rail installation procedures.

---

### Note

---

All TLZ09 and TLZ9L models have a drive buffer size of 1 MB of memory, while the TLZ10 models have a drive buffer size of 2 MB of memory.

---

## TLZ09/9L and TLZ10 Cassette Tape Device Product Description

The TLZ9L autoloader is available in several configurations:

- Model TLZ9L-AA --- a 5 1/4-inch, full-height autoloader that mounts internally (see Figure 7-1). This unit comes with a light gray (DEC 217) bezel installed and a dark gray (DEC 277) bezel in the shipping carton, along with bezel removal/mounting procedures.
- Model TLZ9L-DB (tabletop) --- a dark gray (DEC 277) external unit with a built-in power supply and fan (see Figure 7-2).
- Model TLZ9L-VA/VB --- a TLZ9L-AA mounted in a 5 1/4-inch StorageWorks SBB.

**Figure 1-1 Model TLZ09-DA/DB and DS-TLZ10-DB (Tabletop)**

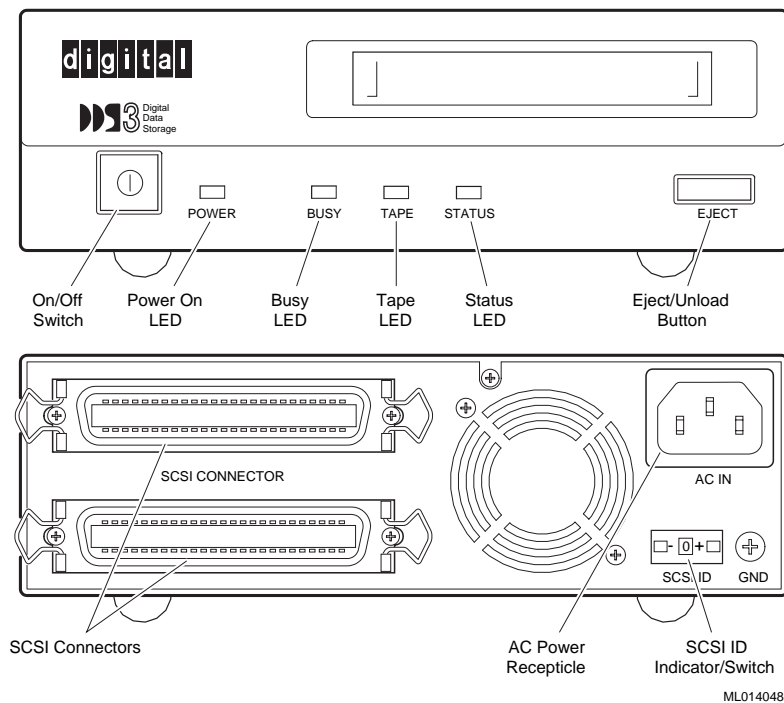

---

### Note

Names for bezel LEDs, Eject button, Power button, and the DDS-3 logo appear only on the TLZ10 bezel.

---

## TLZ09/9L and TLZ10 Cassette Tape Device Product Description

**Figure 1-2 Model TLZ09-AA/AB and TLZ10-AB (3.5-inch Chassis)**

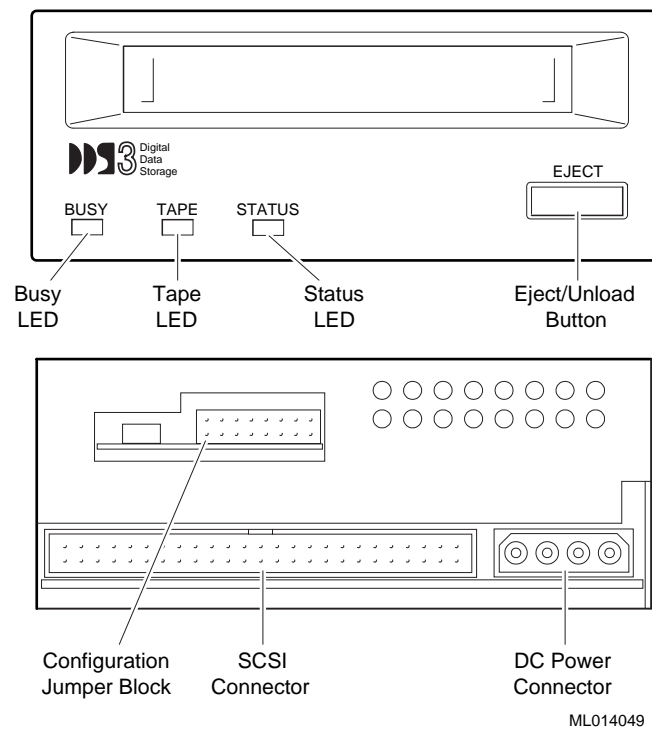

---

### Note

Names for bezel LEDs, Eject button, and the DDS-3 logo appear only on the TLZ10 bezel.

---

## TLZ09/9L and TLZ10 Cassette Tape Device Product Description

**Figure 1-3 Model TLZ09-BA/BB and TLZ10-BB (5.25-inch Chassis)**

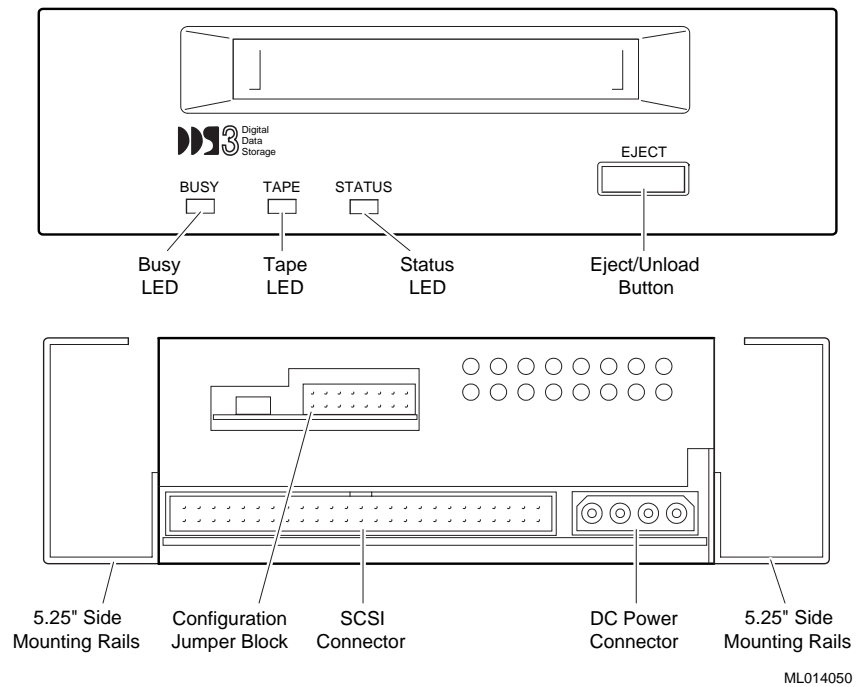

---

### Note

Names for bezel LEDs, Eject button, and the DDS-3 logo appear only on the TLZ10 bezel.

---



## TLZ09/9L and TLZ10 Cassette Tape Device Product Description

**Figure 1-4 TLZ09/TLZ10 Chassis - Underside with Switch Pack**

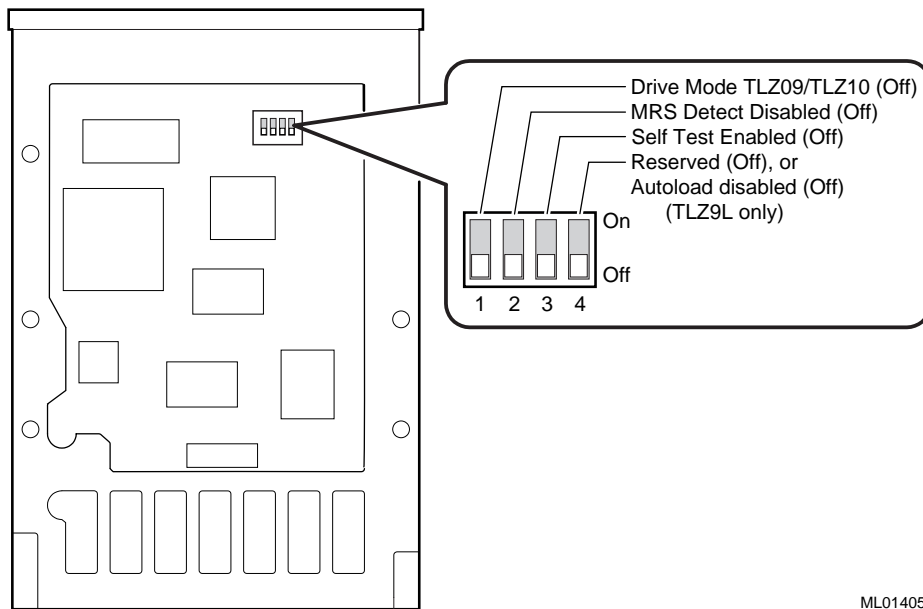

ML014051

## TLZ09/9L and TLZ10 Cassette Tape Device Product Description

### 1.3.1 Checking Your Shipment for Model TLZ09/TLZ10 Tabletop Drives

In addition to this manual, make sure that your shipment includes the following:

- One TLZ09-DA/DB or DS-TLZ10-DB tabletop cassette tape drive
- For TLZ09 only, one 50-pin to 50-pin (low density to high density connector) SCSI signal cable for drive to system connections. PN 17-04356-01 is frost white and is packaged with the TLZ09-DB, while PN 17-03742-09 is gray and is packaged with the TLZ09-DA. In the future, black cables may be substituted for both of these variations. No SCSI cable ships with the TLZ10 tabletop (DS-TLZ10-DB).
- AC power cable
- One blank cassette tape (4 mm x 120 m), (PN TLZ07-CA) for TLZ09 or (4 mm x 125 m), (PN TLZ10-CA) for TLZ10
- One head cleaning cassette (PN TLZ04-HA)
- Active SCSI terminator [PN 12-44026-01 (frost white) for TLZ09 only or PN 12-41807-01 (gray)]. In the future, black terminators may be substituted.

If your shipment is incomplete, please contact your DIGITAL sales representative.

### 1.3.2 Checking your Shipment for Model TLZ9L-DA/DB

In addition to this manual, make sure that your shipment includes the following:

- One TLZ9L-DA/DB tabletop autoloader
- One 50-pin to 50-pin (low density to high density) SCSI signal cable for drive to system connections. PN 17-04356-01 is shipped at present, but may be replaced with a black cable in the future.
- AC power cable
- Eight blank cassette tapes (4 mm x 120 m, PN TLZ07-CA) preloaded in an eight-slot tape cassette magazine (PN TLZ9L-08)
- One head cleaning cassette tape (PN TLZ04-HA)
- Active SCSI terminator. PN 12-44026-01 is shipped at present, but may be replaced with a black terminator in the future.

If your shipment is incomplete, please contact your DIGITAL sales representative.

## TLZ09/9L and TLZ10 Cassette Tape Device Product Description

### 1.3.3 Ordering Additional Cassettes

To order additional blank cassette tapes and head cleaning cassettes, contact your DIGITAL sales representative or DECdirect. Refer to the following part numbers.

Five blank cassette tapes (4 mm x 60 m) (PN TLZ04-CB)

Five blank cassette tapes (4 mm x 90m) (PN TLZ06-CB)

Ten blank cassette tapes (4 mm x 120m) (PN TLZ07-CB)

Ten blank cassette tapes (4 mm x 125m) (PN TLZ10-CB)

One head cleaning cassette (PN TLZ04-HA)

### 1.3.4 Visiting Web Site for the Latest Information

Check the storage web page for the latest drivers, technical tips, and documentation. This information can be found in the technical area of the storage web page at:

<http://www.storage.digital.com/>



---

## **Installing the Tabletop Drive or Autoloader**

### **2.1 General**

This chapter shows you how to install the TLZ09-DA/DB or DS-TLZ10-DB tabletop cassette tape drive or TLZ9L-DA/DB tabletop cassette tape autoloader on systems with an external SCSI connector. Read the following sections to complete the installation.

### **2.2 Shut Down, Halt, and Power Off the System**

If you are installing a TLZ09-DA/DB or DS-TLZ10-DB tabletop cassette tape drive or a TLZ9L-DA/DB tabletop cassette tape autoloader on a running system, have your system manager perform the following steps:

1. Shut down the operating system.
2. Halt the system.
3. Set all system power switches off.

## Installing the Tabletop Drive or Autoloader

### 2.3 Selecting the SCSI Address

To familiarize yourself with the TLZ09 or TLZ10 drive and the TLZ9L autoloader:

1. Refer to Figure 1-1 for the location of the buttons, switches, and connectors on the tabletop drive and to Figure 7-2 for the location of the buttons, switches, and connectors on the tabletop autoloader.
2. Note that all connections are made at the rear of the tabletop enclosure.

Your system uses a SCSI ID switch to identify, or address, the drive. The SCSI ID is factory set at **0**. If you are installing the drive on a system that is already using SCSI ID 0, use any available SCSI ID. (You may have to consult your system manager.)

To set/change the SCSI address:

1. Locate the SCSI address switch at the rear of the tabletop enclosure.
2. Select the SCSI address for the drive or autoloader. Press the + or - button until the desired address (0 through 7) appears in the window. See Figure 1-1 for the drive and Figure 7-2 for the autoloader.

---

#### Note

---

If you are installing any other drive variant, refer to Chapter 3.  
Turn off all power before connecting the cables and the terminator.  
The drive must be turned off and then on for switch settings to take effect, or a SCSI bus reset must be received.

---

The tabletop devices provide two SCSI connectors to allow daisy chaining. Either connector can connect to the host computer or any SCSI device in a daisy chain.

- If the tabletop is the last device in the chain, an interface cable is attached to one connector and an active SCSI terminator is installed in the other connector.
- If the device is within the chain, the interface cable from the preceding device is connected in one connector; an interface cable is also connected from the other connector to the following device.

## Installing the Tabletop Drive or Autoloader

---

### Note

---

Make sure that the last SCSI device on the bus is terminated correctly and is jumpered to supply termination power. Also ensure that cable lengths are within SCSI specification requirements (see Section 2.5).

---

## 2.4 Connecting a SCSI Signal Cable --- Device to System

You should use a cable supplied by Digital Equipment Corporation. Failure to do so can result in degraded performance of your tabletop device. If you do not have a DIGITAL supplied SCSI cable, contact your DIGITAL sales representative.

To connect a SCSI cable --- device to system --- perform the following:

1. Connect one end of the cable to the system SCSI connector.
2. Connect the other end of the SCSI signal cable to either SCSI connector on the rear of the device.
3. Secure the SCSI cable by snapping the wire cable clamps (on either side of the SCSI connector) into place.
4. Connect the SCSI terminator to the other SCSI connector on the rear of the device.
5. Secure the terminator by snapping the wire cable clamps (on either side of the SCSI connector) into place.

## Installing the Tabletop Drive or Autoloader

### 2.5 Adding Another Tabletop Device --- Device to Device

If you have one SCSI tabletop device already connected to your system, you can connect the TLZ09-DA/DB or DS-TLZ10-DB drive or the TLZ9L-DA/DB autoloader to that device. For device to device connections, use a 50-pin low density to 50-pin low density SCSI signal cable [PN 17-03926-02 (gray), 17-04370-01 (frost white), or equivalent].

Care should be taken to ensure that total SCSI cable length is well within the SCSI specification limit of 6 meters for 5 MB/s transfer speeds (including cable length within the system enclosure). When operating at FAST SCSI (10 MB/s) transfer speeds, the total cable length *must not* exceed 3 meters. It is also important to ensure that the drive is configured to supply terminator power to the bus (default configuration). See Chapter 3 or Chapter 7 for jumper/switch configurations.

1. If present, remove the SCSI terminator from the existing SCSI drive.
2. Connect one end of the SCSI signal cable (see part numbers above) to the existing SCSI device, observing the correct orientation of the cable connector.
3. Secure the SCSI cable by snapping the wire cable clamps (on either side of the SCSI connector) into place.
4. Connect the other end of the SCSI signal cable to either SCSI connector on the device, observing the correct orientation of the cable connector.
5. Secure the SCSI cable by snapping the wire cable clamps (on either side of the SCSI connector) into place.
6. Connect the SCSI terminator (PN 12-44026-01 or 12-41807-01) to the other SCSI connector on the device, observing the correct orientation of the cable connector.

### 2.6 Connecting the Power Cable

The tabletop devices have an autoranging power supply. Refer to Table A-1 or Table A-4 for voltage specifications.

To connect the power cable, proceed as follows:

1. Be sure that the device power switch is off (0).
2. Connect the power cable to the device power connector.
3. Connect the other end of the power cable to a nearby ac outlet.

Proceed to Chapter 4.



---

## Installing the 3.5-Inch or 5.25-Inch Cassette Tape Drive

### 3.1 General

This chapter shows you how to install the TLZ09-AA/AB or TLZ10-AB 3.5-inch form factor and the TLZ09-BA/BB or TLZ10-BB 5.25-inch form factor cassette tape drives in a system enclosure or external expansion box. Read the following sections to complete the installation.

### 3.2 Shut Down, Halt, and Power Off the System

If you are installing a TLZ09 or TLZ10 drive on a running system, have your system manager perform the following steps:

1. Shut down the operating system.
2. Halt the system.
3. Set all system power switches off.

### 3.3 Selecting the Jumper and Switch Configuration for the Drive

To familiarize yourself with the TLZ09 or TLZ10 drive:

1. Refer to Figure 1-2 through Figure 1-4 for the location of the buttons, switches, and connectors on the drive.
2. Note that all connections are made at the rear of the drive.

## Installing the 3.5-Inch or 5.25-Inch Cassette Tape Drive

### 3.3.1 SCSI ID Address Jumpers

Your system uses a SCSI ID jumper block to identify, or address, the drive. The SCSI ID is factory set at **0**. If you are installing the TLZ09 or TLZ10 on a system that is already using SCSI ID 0, use any available SCSI ID. (You may have to consult your system manager.)

To set/change the SCSI address, refer to Figure 1-2 and Figure 1-3 for jumper block location, then:

1. Refer to Figure 3-1 for jumper configuration.
2. Select a unique address number with the first three jumpers on the left.

Table 3-1 shows the SCSI IDs (0 through 7) and Figure 3-1 shows a close-up view of the jumpers.

---

#### Note

---

If you are installing the tabletop variant, refer to Chapter 2.  
Turn off all power before connecting the cables.  
The drive must be power cycled for switch settings to take effect, or a SCSI bus reset must be received.

---

---

#### Note

---

Make sure that both ends of the SCSI bus are terminated correctly. For the drive, termination is enabled by installing a jumper on pins 13 and 14 of the jumper block.

---

## Installing the 3.5-Inch or 5.25-Inch Cassette Tape Drive

**Table 3-1 SCSI ID Jumper Settings (0=Removed, 1=Installed)**

SCSI ID	Pins 1 and 2	Pins 3 and 4	Pins 5 and 6
0	0	0	0 (default setting)
1	0	0	1
2	0	1	0
3	0	1	1
4	1	0	0
5	1	0	1
6	1	1	0
7	1	1	1

**Figure 3-1 Configuration Jumper Block**

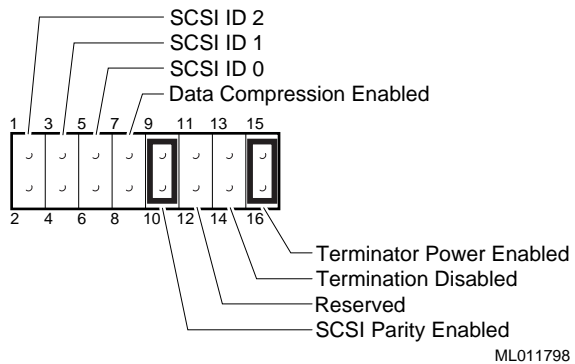

**Note**

The drive must be powered down and then powered up for new jumper settings to take effect.

## Installing the 3.5-Inch or 5.25-Inch Cassette Tape Drive

### 3.3.2 Other Optional Jumper Settings

The remaining jumpers allow you to set up the following configuration options:

- Parity enable/disable (jumper 9--10): Default = parity enabled (jumper installed on pins 9--10)
- Compression enable/disable at power up (jumper 7--8): Default = compression enabled at power up (jumper removed from pins 7--8)
- Termination enable/disable (jumper 13--14): Default = termination disabled (jumper removed from pins 13--14)
- Terminator power enable/disable (jumper 15--16): Default = terminator power enabled (jumper installed on pins 15--16)

Figure 3-1 shows the default settings for these jumpers.

---

#### Note

---

The drive must be turned off and then on for switch settings to take effect, or a SCSI bus reset must be received.

Although jumper 7--8 is removed by default (compression enabled), you may turn compression on and off with a software switch. Consult Appendix B or Appendix C for the command format or refer to your system documentation.

---

### 3.3.3 Drive Switch Settings

The drive switch (see Figure 3-2) allows you to configure the following options:

- Drive Mode (S1): Switch defaults to off for TLZ09 or TLZ10 mode (on indicates generic mode).
- Media Recognition System Detect Enable/Disable (S2): Switch defaults to off for no MRS detection.
- Self-Test Enable/Disable (S3): Switch defaults to off to enable diagnostic self-test a power-up and reset.
- Reserved (S4): This switch is reserved and should be in the off position for the standalone drive. When the drive is embedded within the TLZ9L autoloader, this switch enables the autoloader function of the TLZ9L (see Section 7.4.3.8).

## Installing the 3.5-Inch or 5.25-Inch Cassette Tape Drive

Table 3-2 lists the four drive switches with the default settings. Figure 3-2 shows the location of the drive switch pack.

**Table 3-2 Drive Switch Default Settings**

Switch	Default Setting	Function
SW1	OFF	Drive Mode/Loader Mode (TLZ09, TLZ10, or TLZ9L)
SW2	OFF	MRS Detect Disabled
SW3	OFF	Self-Test Enabled
SW4	OFF	Reserved (TLZ09 and TLZ10), Autoload Disabled (TLZ9L)

**Figure 3-2 Drive Switch Settings**

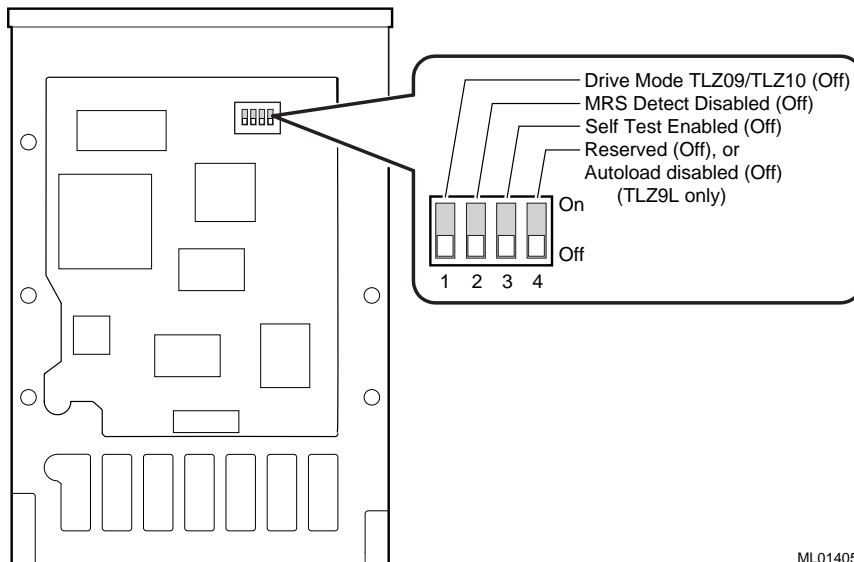

ML014051

## Installing the 3.5-Inch or 5.25-Inch Cassette Tape Drive

### **3.4 Connecting a SCSI Signal Cable --- Drive to System**

You should use a cable supplied by Digital Equipment Corporation. Failure to do so can result in degraded performance of your TLZ09 or TLZ10 drive. If you do not have a DIGITAL supplied SCSI cable, contact your DIGITAL sales representative.

To connect a SCSI cable --- drive to system --- perform the following:

1. Connect one end of the cable to the system SCSI connector.
2. Connect the other end of the SCSI signal cable to the SCSI connector on the rear of the drive (see Figure 1-2 and Figure 1-3).

### **3.5 Connecting the Power Cable and Mounting**

Connect the system internal power cable located at the rear of the drive (see Figure 1-2 and Figure 1-3).

---

## Verifying TLZ09/TLZ10 Cassette Tape Drive Installation

### 4.1 General

To verify successful installation of the TLZ09 or TLZ10 drive, execute the power-on self-test (POST).

#### 4.1.1 Execute POST

To execute POST:

1. For a tabletop unit, press the power switch to the on or | position (see Figure 1-1). For a drive in a system enclosure, turn the system power source to the ON position.
2. Observe that after a two second delay, with no cassette in the drive, the LEDs will flash off and on twice, followed by each LED lighting in a sequence from left to right until the completion of self-tests.

With a cassette in the drive, the Tape and Busy indicators will continue flashing (approximately 20 seconds) after completion of the above sequence until the cassette is loaded.

3. After successful completion of POST, all LEDs will be extinguished. If a cassette is loaded, the Tape LED will remain on. If the cassette is write-protected, the Status LED will also remain on.

## Verifying TLZ09/TLZ10 Cassette Tape Drive Installation

4. If the Status LED flashes twice every 1.25 seconds with the flashes occurring close together followed by some delay, then POST failed. Attempt to clear the failure by re-executing POST. (Power off and power on the drive.) If the failure repeats itself, call Multivendor Customer Services.

After successful execution of POST, have your system manager restart the system and assign a device name to your TLZ09 or TLZ10 drive if necessary. Optionally, you can run a full system or SCSI bus test. See your system owner's manual for specific instructions.

---

### **Note**

---

If a tape is loaded, the Tape indicator stays on. If the tape is write-protected, the Status indicator will also remain on.

---



---

## Using the TLZ09/TLZ10 Cassette Tape Drive

### 5.1 General

This chapter describes how to use the TLZ09 and TLZ10 drives, buttons, and indicators (see Figure 1-1 through Figure 1-3). It also describes how to use cassette tapes.

### 5.2 Power Switch

For a tabletop unit, press the power switch to turn the drive on or off. If you are not using the drive for prolonged periods of time, check with your system manager for the correct procedure to shut down your system or power off the drive.

### 5.3 Unload Button

Press and hold the unload button for 1 to 2 seconds to eject the cassette tape.

---

**Caution**

---

Pressing the unload button during normal tape operations will halt the tape operation in progress.

---

## Using the TLZ09/TLZ10 Cassette Tape Drive

### 5.4 Tape Drive LEDs

The Busy, Tape, and Status LEDs provide information on a variety of operational conditions on the drive. Table 5-1 describes these indicators. The LED color is green for all three LEDs. See Figure 1-1 through Figure 1-3 for LED locations on the bezel.

#### 5.4.1 Status LED

This indicator comes on solid when the cassette is write-protected. It also has other indications as documented in Table 5-1.

#### 5.4.2 Tape LED

This indicator comes on solid when a cassette is loaded. It flashes during loading and unloading. It also has other indications as documented in Table 5-1.

#### 5.4.3 Busy LED

This indicator comes on during SCSI, or drive activity. See also Table 5-1.

**Table 5-1 TLZ09/TLZ10 LED Status**

Condition	Busy LED	Tape LED	Status LED
No tape loaded	Off	Off	Off
Tape loaded, write-enabled	Off	On	Off
Tape loaded, write-protected	Off	On	On
No SCSI/Drive activity	Off	Tape load status	Write-protect status
SCSI/Drive activity	On during SCSI activity, flashes twice per second on drive activity	Tape load status	Write-protect status
Load/Unload sequence	Flashes twice per second during sequence, then indicates activity	Flashes twice per second, then indicates either tape loaded (on) or unloaded (off)	Write-protect status

## Using the TLZ09/TLZ10 Cassette Tape Drive

**Table 5-1 (Cont.) TLZ09/TLZ10 LED Status**

<b>Condition</b>	<b>Busy LED</b>	<b>Tape LED</b>	<b>Status LED</b>
Reset sequence	Flashes on for 1 second	Off, then indicates tape load status.	Off, then indicates write-protect status.
Power-on with POST enabled	Off for two seconds, then flashes twice in one second. Then flashes in sequence with Tape and Status LEDs left to right. This repeats until self-tests complete.	Off for two seconds, then flashes twice in one second. Then flashes in sequence with Busy and Status LEDs, left to right. This repeats until self-tests complete.	Off for two seconds, then flashes twice in one second. Then flashes in sequence with Busy and Tape LEDs, left to right. This repeats until self-tests complete.
Tests Complete, No Failure	Normal operation	Normal operation	Normal operation
Self-Test failure	Not applicable	Not applicable	Flashes twice every 1.25 seconds with the flashes occurring close together, then some delay.
Power-On with POST disabled	Off for two seconds, then flashes twice in one second	Same as Busy	Same as Busy
Error Rate Warning	Not applicable	One long flash every four seconds. Media may need changing or drive needs to be cleaned.	Not applicable
Drive mechanism failure (may be recoverable)	Not applicable	Not applicable	Flashes once every 1.25 seconds
Drive mechanism failure (unrecoverable, fatal error)	Flashes once every 1.25 seconds	Not applicable	Not applicable
Drive cleaning request (timer expired)	Not applicable	Not applicable	One long flash every four seconds. Clean drive.

## Using the TLZ09/TLZ10 Cassette Tape Drive

**Table 5-1 (Cont.) TLZ09/TLZ10 LED Status**

<b>Condition</b>	<b>Busy LED</b>	<b>Tape LED</b>	<b>Status LED</b>
Cleaning tape inserted (good tape)	Flashes twice per second during cleaning cycle, then indicates activity. On during subsequent unload sequence.	On	On if drive was not requesting a cleaning. One long flash every four seconds if drive was requesting a cleaning cycle. On during subsequent unload sequence.
Cleaning tape inserted (expired tape)	Off	On	Flashes twice per second. Continues until eject button is pushed, at which time a normal unload cycle is initiated.
Firmware upgrade tape loaded is not for this device	Not applicable	Flashes twice every 1.25 seconds with the flashes occurring close together, then some delay.	Not applicable

## Using the TLZ09/TLZ10 Cassette Tape Drive

### 5.5 Using the Cassette Tape

Digital Equipment Corporation recommends that you use only DDS certified tapes. The following sections describe how to:

- Handle and store tape (Section 5.5.1)
- Write-protect tape (Section 5.5.2)
- Insert and remove tape (Section 5.5.3)

---

#### **WARNING**

---

**Always place the tape label in the recessed area on the cassette. Never place one label on top of another label, or the tape could get jammed.**

---

---

#### **Note**

---

Use of non-DDS media may result in degraded drive performance. We recommend the use of Digital Equipment Corporation media.

---

#### 5.5.1 Proper Handling of Cassette Tapes

To ensure optimal performance from your cassette tapes, observe the following guidelines when handling them.

- Avoid placing the cassette tapes near sources of electromagnetic interference, such as terminals, and video or X-ray equipment. Emissions from such equipment can erase data on the tape.
- Keep cassette tapes out of direct sunlight and away from heaters and other sources of heat.
- Store cassette tapes (and cleaning cassette) where the room temperatures are between 5 and 32°C (40 and 90°F).
- Store cassette tapes in a dust-free environment where the relative humidity is 20 to 60% RH.

## Using the TLZ09/TLZ10 Cassette Tape Drive

### 5.5.2 Setting the Write-Protect Tab on the Cassette Tape

If you are using the tape to read or are copying from the tape, we recommend that you set the write-protect tab to write-protected. This disables writing to tape, and ensures that data will not be accidentally overwritten. The write-protect tab contrasts in color to the cartridge body. Use a pen (NOT A PENCIL) to set the write-protect tab (Figure 5-1) to the desired position.

---

#### Note

---

The tab is not visible when the cassette tape is loaded in the drive.

---

**Figure 5-1 TLZ09/TLZ10 Cassette Tape**

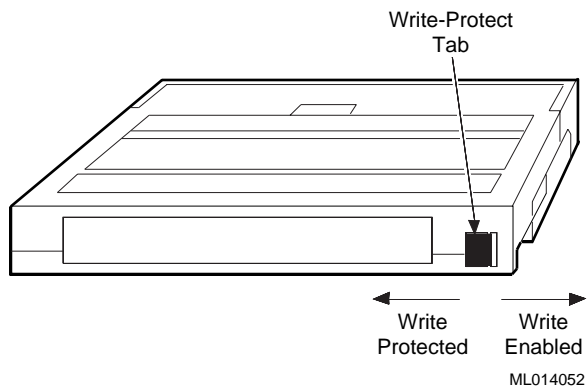

Observe the following guidelines when setting the write-protect tab.

- If you are reading data (copying from the tape), set the write-protect tab to write-protected by sliding the tab to the left.
- If you are writing data, set the write-protect tab to write-enabled by sliding the tab to the right.
- The write-protect tab position is shown on the front panel Write-Protect indicator. Status LED remains lit to indicate Write Protected.

## Using the TLZ09/TLZ10 Cassette Tape Drive

### 5.5.3 Inserting a Cassette Tape into the Drive

Insert the cassette tape into the drive with the cassette's write-protect tab on the right, facing you. Remove the tape by depressing the tape eject button.

---

#### **Caution**

---

The drive should never be transported with a tape loaded in the drive. Tape damage and possible loss of data may result. Always unload the tape prior to transporting the drive.

---





---

# Preventive Maintenance and Problem Solving

## 6.1 Introduction

This chapter describes preventive maintenance and problem solving for the TLZ09 and TLZ10 cassette tape drives. Preventive maintenance involves periodic head cleaning. Problem solving is described in Table 6-1.

Statistics show that over 90% of drive-related problems are associated with the media. Therefore, Digital Equipment Corporation strongly recommends that you follow the instructions for handling cassette tapes and cleaning the heads of the drive.

## 6.2 Cleaning the Heads

This section describes how to perform drive head cleaning. The heads are the components that physically read and write data to and from the media (in this case, a cassette tape).

**Digital Equipment Corporation recommends that you perform the head cleaning procedure once every 2 weeks, or after every 24 hours of drive usage, whichever comes first.**

**Under normal conditions, it should not be necessary to exceed this cleaning schedule. If media related errors begin to occur after only a few hours of use with a new cartridge, you may either have a particularly “dirty” tape or the application you are running may be harder on the media than most typical applications. If this occurs, you may want to revise the cleaning schedule with new tapes, such that a cleaning cycle is executed after 4 or 5 hours of use, then continue with the normal 24 hour interval from that point forward. If a particular data cassette causes problems, try changing to another data cassette.**

## Preventive Maintenance and Problem Solving

---

### Caution

---

Never attempt to clean the heads in a manner other than described. Doing so will void the product warranty.

---

To clean the heads, use the head cleaning cassette as follows:

1. Apply power to the drive by pressing the power switch to the ON position on the system external storage expander box, the tabletop drive unit, or the system enclosure for embedded drives.
2. Insert the head cleaning cassette (PN TLZ04-HA) into the drive.
3. With the head cleaning cassette inserted, the drive automatically executes head cleaning. The drive ejects the head cleaning cassette after approximately **30 seconds** if head cleaning is successful.
4. On the card enclosed with the head cleaning cassette, record every time you use the cassette.

Under normal conditions, the head cleaning cassette is used for about 25 cleanings. Additional cassettes are available from your DIGITAL sales representative or DECdirect.

If the number of cleaning cycles of a particular head cleaning cassette has expired, the drive will signal the user by flashing the Status LED while the Busy LED is off and the Tape LED is on (see Table 5-1). Press the eject button to remove the cleaning cassette, as the drive will not automatically eject an expired cleaning cartridge. No cleaning action will have occurred.

## Preventive Maintenance and Problem Solving

### 6.3 Problem Solving

Table 6-1 describes drive problems and possible solutions. See also Table 5-1.

**Table 6-1 Problem Solving**

Symptom	Probable Cause	Possible Solution
Unable to back up or copy data to cassette tape.	Cassette write-protected.	1. Set write-protect tab on cassette to write-enabled.
	No tape in drive.	2. Insert tape.
	Dirty head or bad media.	3. Clean head or replace media.
Tape LED flashes twice per 1.25 seconds with flashes occurring close together.	Error rate warning	Perform head cleaning procedure (see Section 6.2). If error repeats, try another tape.
Status LED flashes once every four seconds.	Cleaning interval timer expired.	Eject tape. Perform head cleaning procedure (see Section 6.2).
Status LED flashes once every 1.25 seconds.	Drive mechanism failure	Eject tape. Power off and power on the drive. If error repeats, call Multivendor Customer Services.
After applying power and self-test has completed successfully, the Tape LED is not lit.	No tape loaded.	Load tape.
Drive not available to system.	Drive not plugged in.	1. Make sure power cable is plugged in and check power.
	SCSI ID jumpers set to incorrect address.	2. Check SCSI ID jumpers.
	Defective SCSI cable.	3. Be sure SCSI cable connections are secure.
	Incorrect termination, or no term power	4. Verify termination and that term power is being supplied to both ends of the bus.
Poor performance or low capacity.	Dirty head or worn media.	1. Clean heads or replace media.
	Operating in non-buffered mode.	2. Host is putting the drive in non-buffered mode. Use SCSI Mode Select command with buffered mode enabled in host software.
	Drive not being kept streaming.	3. Too much other activity in process, or dumping to tape from slow device.

## Preventive Maintenance and Problem Solving

### 6.3.1 System-Based Diagnostics

Your system has system-based diagnostics that can be used to test the TLZ09 and TLZ10 drive.

System-based diagnostics are usually referred to in your system owner's manual as *console-based diagnostics, self-tests, or system exercisers*. Refer to your system documentation for information about these diagnostics.

Before calling Multivendor Customer Services, you can execute system diagnostics to test the drive.

---

#### Note

---

Some system-based diagnostics are subject to software licensing. Consult your DIGITAL sales representative.

---

### 6.4 Service Offerings

DIGITAL offers a wide range of flexible service plans. For the type of plans available and plan details, contact your local DIGITAL service representative.

---

## Using the TLZ9L Cassette Tape Autoloader

### 7.1 Overview

The TLZ9L cassette tape autoloader (Figure 7-1 and Figure 7-3) provides very high capacity unattended backup, as well as support for the full random access command set as defined by SCSI-2. It is packaged in a 5 1/4-inch, full-height form factor with an embedded TLZ09 cassette tape drive, and provides all the functionality and features of the TLZ09.

The TLZ9L autoloader is NOT a field upgrade option for the TLZ09 tape drive. It must be purchased as a single unit. With the 8-cartridge magazine (PN TLZ9L-08), the TLZ9L autoloader provides up to 64 gigabytes of storage.

## Using the TLZ9L Cassette Tape Autoloader

### 7.2 LED Indicators

The basic TLZ9L autoloader has two LEDs labeled BUSY and TAPE. The tabletop TLZ9L autoloader has an additional LED indicator labeled POWER which illuminates when power is applied.

The status of the BUSY and TAPE LEDs during various conditions is described in Table 7-1.

**Table 7-1 BUSY and TAPE LEDs Status**

<b>Condition</b>	<b>BUSY LED Status</b>	<b>TAPE LED Status</b>
Idle	OFF	N/A
SCSI active	Steady green	N/A
Drive active	Flashing green	N/A
Write in progress	Flashing amber	Steady green
Firmware upgrade in progress	Flashing amber	Flashing amber
No cartridge in drive	N/A	OFF
Cartridge in drive	N/A	Steady green
Loading or unloading	N/A	Flashing green

## Using the TLZ9L Cassette Tape Autoloader

**Figure 7-1 Model TLZ9L-AA (Front and Rear View)**

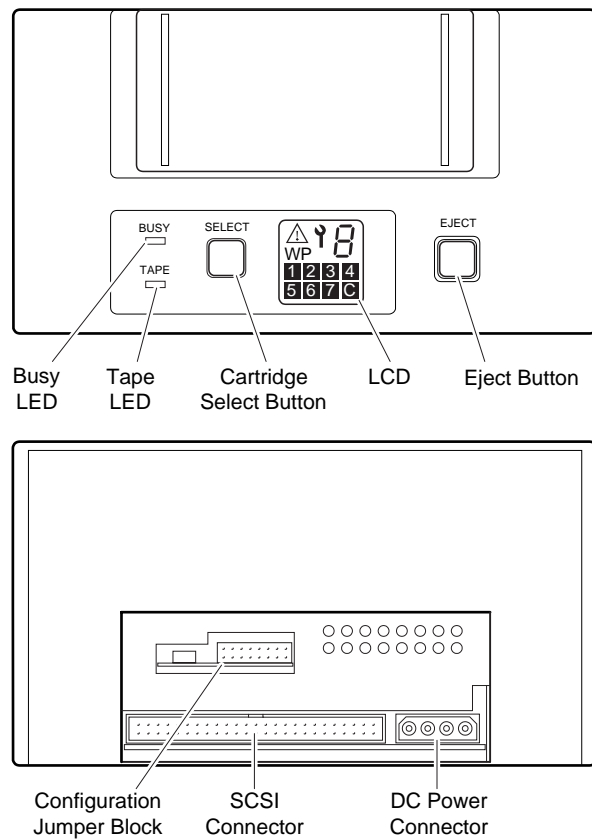

ML014053

---

### Note

See Section 3.3.1 and Section 3.3.2 for embedded drive jumper functions.

---

## Using the TLZ9L Cassette Tape Autoloader

**Figure 7-2 Model TLZ9L-AA Bottom View**

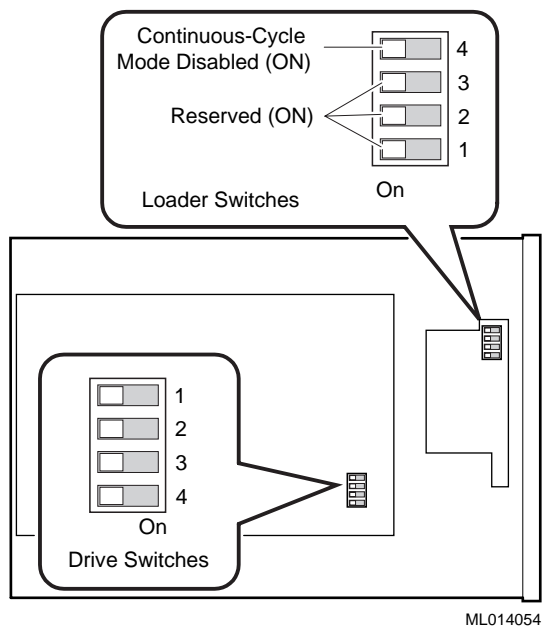

---

**Note**

See Section 7.5.1 for autoloader switch functions and Section 3.3.3 for embedded drive switch functions.

---



## Using the TLZ9L Cassette Tape Autoloader

**Figure 7-3 Model TLZ9L-DA/DB (Front and Rear View)**

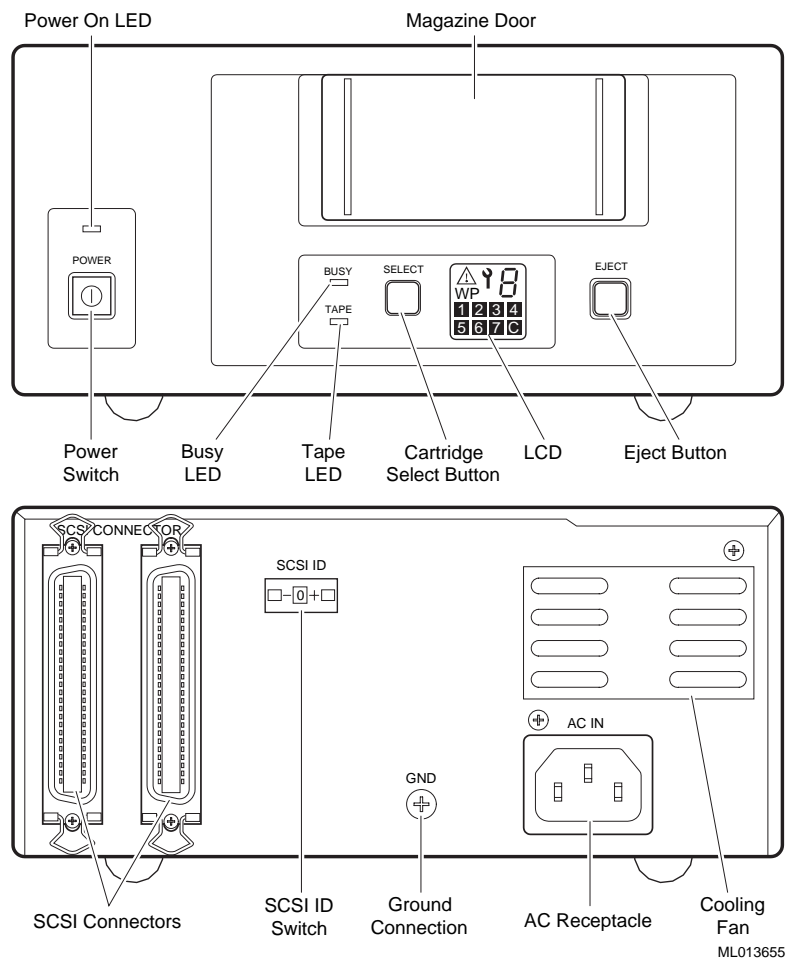

### Note

Embedded drive switches can be accessed via a cutout in the underside of the enclosure beginning with revision A02. See Section 3.3.3 and Figure 3-2 for switch functions. Access to the autoloader switchpack requires the removal of the front bezel.

## Using the TLZ9L Cassette Tape Autoloader

### 7.3 LCD Panel

The liquid crystal display (LCD) panel on the TLZ9L autoloader contains five separate indicators that provide status as well as error information to the user (see Figure 7-4).

**Figure 7-4 TLZ9L LCD Panel**

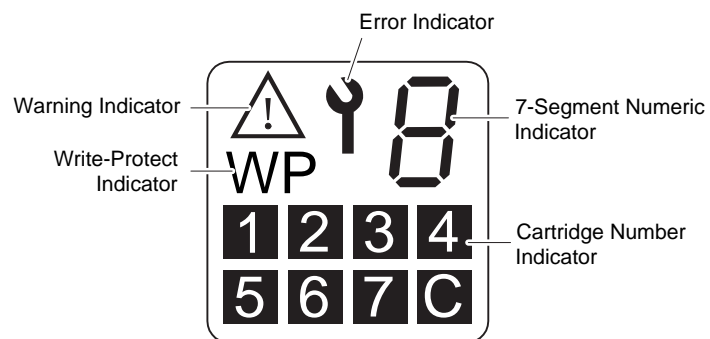





ML013656

## Using the TLZ9L Cassette Tape Autoloader

### 7.3.1 Warning Indicator

The warning indicator is illuminated upon occurrence of a warning condition. When this indicator is lit in combination with a number in the 7-segment display, a particular warning or caution can be indicated. Table 7-2 lists the warning and numeric combinations with a description of what they indicate when lit.

**Table 7-2 Warning Indications**

Indicator and Number	Indication
 1	Indicates a cleaning request. (Drive needs cleaning.) Illuminated upon expiration of a 24 hour timer as well as with the occurrence of certain medium errors. Insert the cleaning tape to clear.
 2	End of tape reached during cleaning. Cleaning did not occur. Discard the cleaning tape, replace with a new cleaning tape, and retry cleaning.
 3	DDS cartridge loaded with incorrect orientation or slide shutter is positioned incorrectly. Remove all cartridges from the magazine, then reload them correctly.
 4	Magazine does not contain correct number of cartridges. Reload magazine with 1, 7, or 8 cartridges.
 5	Firmware upgrade tape inserted is not for TLZ9L.

## Using the TLZ9L Cassette Tape Autoloader

### 7.3.2 Write Protect Indicator

The Write-Protect indicator (WP) is illuminated when a write-protected data cartridge is inserted into the drive. Write-protect can be set by the write-protect tab on either the magazine (write-protects all cartridges in the magazine) or the individual tape cartridge (write-protects the individual data cartridge). Figure 5-1 shows the write-protect tab on the individual tape cartridge and Figure 7-5 shows the write-protect tab on the magazine.

**Figure 7-5 TLZ9L Cassette Magazine**

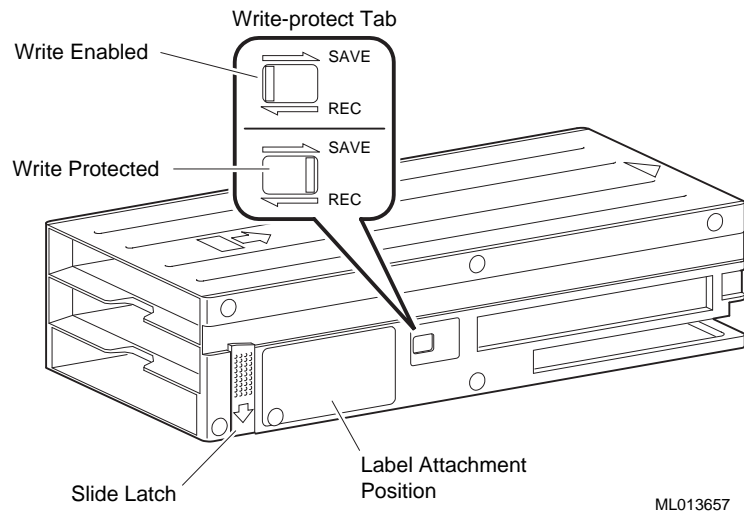

---

#### Caution

---

The write protection status of the magazine is determined by checking the reflective plate on the write-protect tab. In order to ensure correct determination of the status, keep the plate reasonably clean, and never affix labels or the like over the write-protect tab.

If a magazine label is used, ensure that it is properly positioned in the recessed "label attachment area." Improper positioning could cause the magazine to jam.





---

## Using the TLZ9L Cassette Tape Autoloader

### 7.3.3 Error Indicator

The error indicator is illuminated when certain errors occur. When this indicator is lit in combination with a number in the 7-segment display, a particular error can be indicated. Table 7-3 lists the error and numeric combinations with a description of what they indicate when lit.

**Table 7-3 Error Indications**

Indicator and Number	Error Message
 1	Loader mechanism error. Call service personnel.
 2	Embedded drive error. Call service personnel.
 3	Media error. Replace tape cartridge.
 4	Cartridge stuck in the drive. Call service personnel.

### 7.3.4 7-Segment Numeric Display

The 7-segment display normally displays the number of the data cartridge that is currently loaded in the drive.

When the Select button is pushed, this 7-segment display shows the number of the cartridge that has been selected. After 5 seconds, the selected cartridge will be loaded into the drive.

When either the Warning or Error indicators are lit, the 7-segment display indicates the specific type of warning or error (see Table 7-2 and Table 7-3).

## Using the TLZ9L Cassette Tape Autoloader

### 7.3.5 Cartridge Number Indicators

The eight boxes at the bottom of the LCD panel are individually lit to indicate which slots in the magazine contain cartridges. The boxes will blink to indicate that a cartridge is being loaded. A box that is not lit indicates that a cartridge is not in that slot of the magazine (for example, the cartridge is loaded in the drive). The box will become lit again once the cartridge is returned to that slot in the magazine.

## 7.4 TLZ9L Operation

The TLZ9L cassette tape autoloader can operate in two ways; automatically or manually. It can also be operated in two modes; sequential or random access.

---

### Caution

---

Never transport the autoloader with a magazine installed. Damage to the tapes, autoloader, or magazine may result due to movement of the magazine. Data loss may occur if a tape is loaded in the drive. Always unload the magazine prior to transporting the autoloader.

---

### 7.4.1 Automatic Operations

During automatic operations, the TLZ9L cassette tape autoloader can function in sequential and random access modes at the same time.

In sequential mode, upon receipt of a SCSI unload command, the autoloader unloads the current cassette and automatically cycles to the next cassette in the magazine. It continues to unload and cycle to the next cassette until the last cassette has been unloaded. When this process is complete, the magazine stops to prevent accidental overwrite of data unless the continuous cycle switch (see Section 7.5.1 and Figure 7-1) is set. When the magazine stops, it may then be unloaded.

In random access mode, the autoloader responds to all of the SCSI random access commands.

## Using the TLZ9L Cassette Tape Autoloader

### 7.4.2 Manual Operations

Manual operations are performed from the front panel of the TLZ9L autoloader.

To load a magazine, simply insert the magazine into the magazine door (see Figure 7-9). Once the magazine has been inserted part way, the mechanism will pull it into the autoloader automatically. If there is already a magazine in the autoloader, it must first be ejected by pressing the Eject button on the front panel. This ejects any cartridge in the drive and then ejects the magazine. Once the magazine is inserted, the autoloader scans the magazine checking each slot for the presence of a cartridge and verifying proper cartridge orientation. This scanning process can take up to 90 seconds.

To load a cartridge into the drive, press the Select button on the front panel until the desired cartridge/slot number is indicated in the 7-segment display. The autoloader delays loading a cartridge for 5 seconds to give the user time to cycle to another cartridge if desired. If a cartridge is already loaded in the drive, the autoloader will unload that cartridge, place it back in the magazine, and then load the selected cartridge.

### 7.4.3 Magazine Operations

The TLZ9L cassette tape autoloader supports three basic magazine configurations. These configurations are 8, 7, and single-cartridge modes. Any other number of cartridges is not supported and will cause the magazine to eject. See Section 7.4.3.4 for the procedure on loading cartridges into the magazine and Section 7.4.3.7 for the procedure on unloading cartridges from the magazine.

#### 7.4.3.1 Eight Cartridge Mode

In eight cartridge mode the magazine accommodates either eight data cartridges or seven data cartridges and one cleaning cartridge. The sequence in which the cartridges are inserted into the magazine determines the numbers by which they are managed as indicated in Figure 7-6. The letter C indicates the cleaning cartridge. If a cleaning cartridge is not used, the C slot can be populated with the eighth data cartridge to provide the highest capacity per magazine.

## Using the TLZ9L Cassette Tape Autoloader

**Figure 7-6 Eight Cartridge Mode**

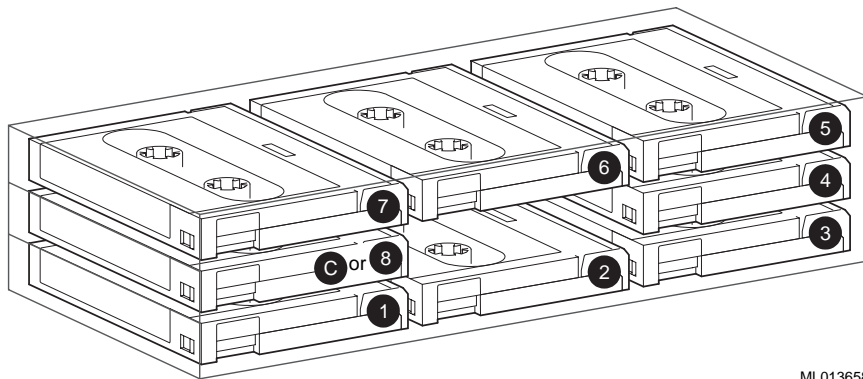

ML013658

### 7.4.3.2 Seven Cartridge Mode

In seven cartridge mode the C slot is left vacant as shown in Figure 7-7. When the magazine is inserted into the autoloader, the C slot is not available for use by the autoloader. Any attempt to access the C slot will generate an error.

**Figure 7-7 Seven Cartridge Mode**

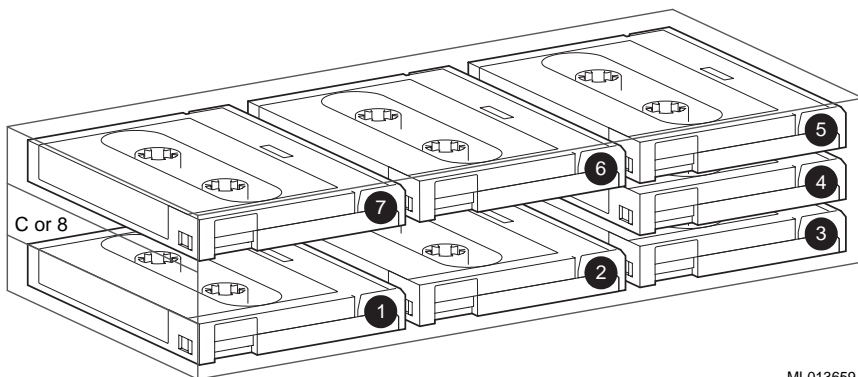

ML013659



## Using the TLZ9L Cassette Tape Autoloader

### 7.4.3.3 Single Cartridge Mode

In single cartridge mode, either a data cartridge or a cleaning cartridge is inserted into the C slot position of the magazine as shown in Figure 7-8.

**Figure 7-8 Single Cartridge Mode**

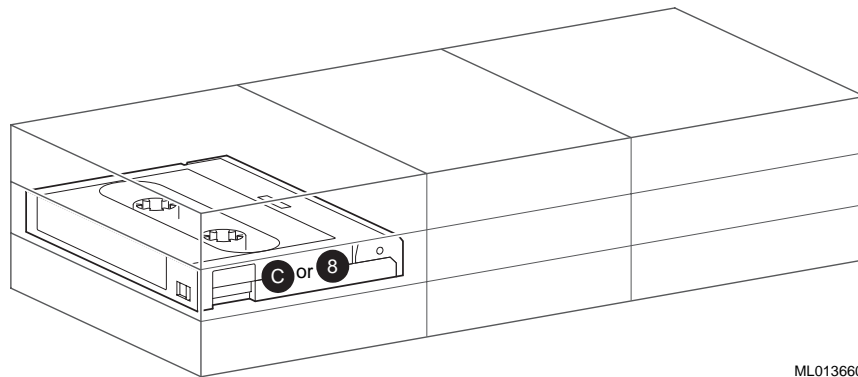

ML013660

## Using the TLZ9L Cassette Tape Autoloader

### 7.4.3.4 Loading Cartridges Into the Magazine

When loading data cartridges into the magazine, the bottom shelf of the magazine should be loaded first. Ensure that the cartridges are oriented correctly as shown in Figure 7-9. Load cartridge 3 in the bottom shelf first, followed by cartridge 2 and then cartridge 1 in that order. It is highly recommended that you number each cartridge by placing a numbered label on the cartridges in order to keep track of each cartridge.

After loading the bottom shelf, start loading the top shelf of the magazine beginning with cartridge 4 and proceeding with cartridge 5, cartridge 6, and cartridge 7 in that order.

If either an 8th data cartridge or a cleaning cartridge is to be used, load it into middle shelf of the magazine.

**Figure 7-9 Loading Cartridges Into the Magazine**

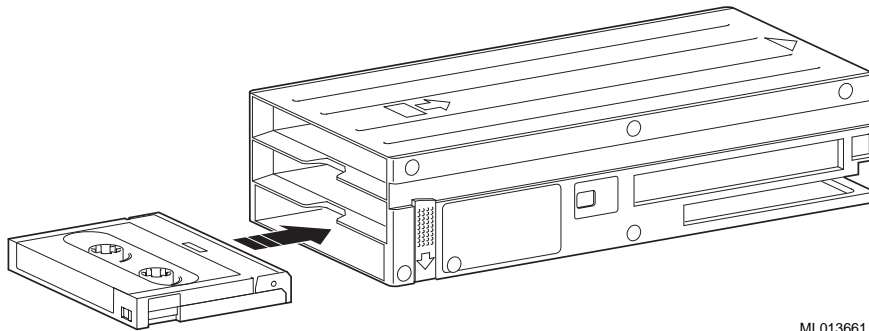

ML013661

## Using the TLZ9L Cassette Tape Autoloader

### 7.4.3.5 Loading the Magazine Into the TLZ9L

To load a magazine into the TLZ9L cassette tape autoloader, first apply power to the autoloader by powering on the system for an embedded autoloader, or by pressing the power switch on the tabletop autoloader. The BUSY and TAPE LED indicators blink as a self-test is performed. When the BUSY and TAPE LED indicators stop blinking, the magazine can be inserted into the autoloader as shown in Figure 7-10. When the magazine is inserted, the TAPE LED indicator lights. If the magazine is write-protected, the write-protect (WP) indicator also lights.

Once the magazine is inserted, the autoloader will cycle through and count the cartridges in the magazine. If any of the cartridges are misoriented, or if the number of cartridges present is other than 1, 7, or 8, the magazine will be ejected. At the end of this initialization, if all of the cartridges are oriented correctly and the correct number of cartridges are present, the autoloader goes to the idle state unless autoload mode is enabled (see Section 7.4.3.8). A cartridge can then be selected and loaded into the drive either manually or through software control.

**Figure 7-10 Loading the Magazine Into the TLZ9L-DA/DB**

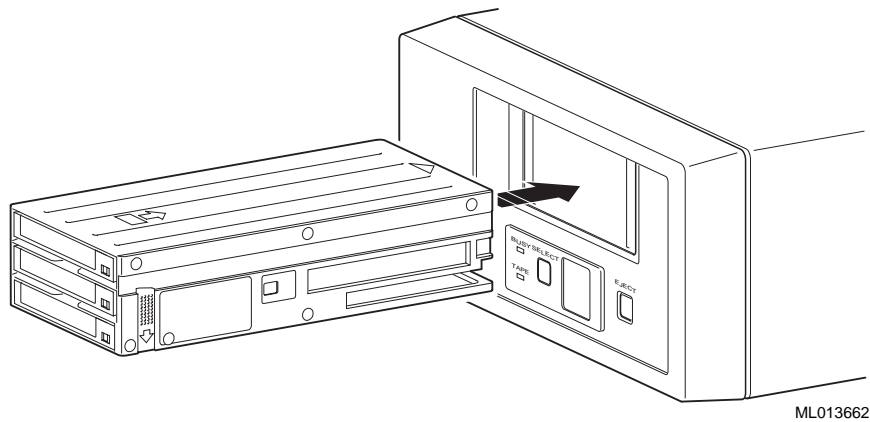

## Using the TLZ9L Cassette Tape Autoloader

### 7.4.3.6 Ejecting the Magazine

Under normal conditions, the magazine can be ejected by simply pressing the Eject button on the front panel. Any cartridge that may be in the drive at the time the Eject button is pressed will be rewound and unloaded back into the magazine. The cartridges are then moved to their original locations within the magazine and the magazine is ejected.

If the TLZ9L autoloader encounters a certain type of fatal error, you may not be able to eject the magazine in a normal manner. However, you still may be able to eject the magazine using an emergency eject. To invoke the emergency eject, press and hold the Eject button for ten seconds while the error indication is displayed in the 7-segment display. If a cartridge is stuck in the drive, the magazine will be ejected without this cartridge being present. The LCD panel will then indicate an error code of 4 and service personnel will need to be called.

## Using the TLZ9L Cassette Tape Autoloader

### 7.4.3.7 Unloading Cartridges From the Magazine

When unloading cartridges from a magazine, it is recommended that the magazine be held over a table or bench so that the cartridges will fall gently to the table top and not fall on the floor where they could be damaged.

Perform the unloading process by pressing down on the magazine slide latch with the thumb of your left hand and then placing the finger of your right hand in the hole at the rear of the magazine and pushing the cartridges toward the front of the magazine (see Figure 7-11). Continue pushing the cartridges all the way to the front of the magazine by using the slot in the bottom of the magazine. This should remove the first five cartridges from the magazine.

Next, orient the magazine with the open end pointing upward and gently tap the magazine against the palm of your hand. This moves the remaining cartridges to the bottom shelf where they can be removed by following the same procedure used for removing the first five cartridges.

Finally, the cartridge in the middle shelf can be removed by grasping it with your thumb and index finger and pulling it out of the magazine while continuing to press down on the magazine slide latch.

**Figure 7-11 Unloading Cartridges From the Magazine**

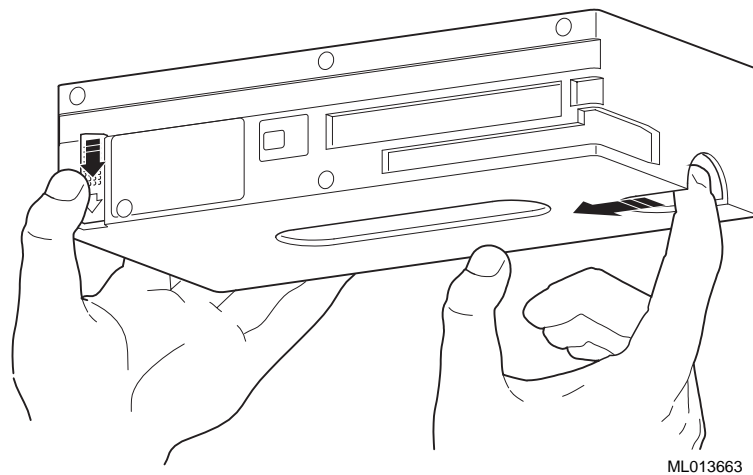

## Using the TLZ9L Cassette Tape Autoloader

### 7.4.3.8 Autoload Function

Switch four on the embedded drive within the TLZ9L autoloader controls the autoload function (see Figure 7-1 and Table 3-2). When this switch is in the ON position, autoload is enabled. For the TLZ9L revision A01, this switch only controls autoload for 7 or 8 cartridge mode. In single tape mode, the tape in the magazine will always be automatically loaded regardless of the position of this switch.

Beginning with revision A02, if the autoload switch is in the OFF position, no tape will be automatically loaded after magazine insertion in 8, 7, or single cartridge mode. If the switch is in the ON position, the first tape will be automatically loaded in 8, 7, or single cartridge mode.

## 7.5 Switch Settings

The following sections describe the switchpack settings on the TLZ9L autoloader and the SCSI ID select switch on the TLZ9L-DA/DB autoloader. It should be noted that all of the drive switches and jumpers still function as documented in Chapter 3 for the drive mounted internal to the autoloader except where noted otherwise. For example, to enable MRS detection on the autoloader, place drive switch S2 to the ON position (see Section 3.3.3 and Figure 3-2).

### 7.5.1 Switchpack Settings

There are two switchpacks on the TLZ9L autoloader. One is on the autoloader and the other is on the embedded drive. The autoloader switchpack contains four switches and is located on the bottom of the autoloader toward the front (see Figure 7-1). It is accessible through a cutout in the sheet metal chassis. If the autoloader is configured as a -VA, a cosmetic panel covering a portion of the cutout will need to be removed by removing two screws. For the tabletop version, access to this switchpack can be gained by removing the front bezel. The top cover will have to be removed in order to remove the front bezel.

Table 7-4 lists the four switches, their default settings, and the function of each. The default setting for all four switches is the ON position.

**Table 7-4 Autoloader Switchpack Settings**

Switch	Default	Function
SW1	ON	Reserved
SW2	ON	Reserved
SW3	ON	Reserved
SW4	ON	Continuous cycle mode disabled. OFF for enabled.

## Using the TLZ9L Cassette Tape Autoloader

---

### Caution

---

Enabling continuous cycle mode (SW4 OFF) may overwrite existing data. This feature is used for diagnostic purposes only.

---

### 7.5.2 SCSI ID Select Switch (TLZ9L-DA/DB Only)

The SCSI ID select switch is located on the rear panel of the TLZ9L-DA/DB tabletop autoloader (see Figure 7-3). The SCSI ID is set by pressing the + or - button until the desired address is displayed. .

## 7.6 Cleaning Requirements

A cleaning tape preventive maintenance program is required. Head cleaning shall be the only preventive maintenance required and shall be accomplished with a tape cleaning cartridge. The DIGITAL part number for the cleaning cartridge is TLZ04-HA. A cleaning cycle should be performed at the following times:

- After every 24 hours of tape use
- When a *request a cleaning cartridge* warning is indicated on the LCD of the operator front panel (i.e. warning sign with a flashing 1). See Table 7-2.

---

### Note

---

If the cleaning request indicator (warning indicator with a flashing 1) appears frequently for a particular cartridge, it is recommended that the cartridge be replaced. Also see Section 6.2.

---

There are basically four methods of accomplishing a cleaning cycle for the TLZ9L.

- Manual:
- Place single cleaning cartridge into slot 8 of magazine (other slots are empty).
  - Insert the magazine into the autoloader.
  - If the autoloader switch is in the OFF (default) position, you will need to push the Select button to select slot 8. After 5 seconds, the cleaning tape will be loaded into the drive and a cleaning cycle will be executed. The cartridge will then be returned to the magazine and the magazine will be ejected from the autoloader.
  - If the autoloader switch is in the ON position, the autoloader will automatically load the cartridge into the drive, execute the cleaning cycle, then return the cartridge to the magazine, and eject the magazine.

## Using the TLZ9L Cassette Tape Autoloader

- Sequential Mode:
- Place the cleaning cartridge into any magazine slot along with data cartridges appropriate for the mode of operation (i.e. 7 cartridge mode, or 8 cartridge mode).
  - Insert the magazine into the autoloader.
  - Use the select button to select the slot with the cleaning cartridge.
  - Autoloader will load the cartridge into the drive, execute the cleaning cycle, then return the cartridge to the magazine.
  - If you then press the select button once, it will select the next sequential data cartridge after the data cartridge that was loaded into the drive last. (i.e. If you had cartridge 3 loaded, then pushed the select button to select and load the cleaning cartridge from its slot, the next time you push the select button after the cleaning cycle has completed, it will load cartridge 4.)
- Sequential Backup Mode:
- Place the cleaning cartridge into any magazine slot along with data cartridges.
  - Execute sequential backup via chosen software utility.
  - When EOD is reached and reported to host, host will issue UNLOAD command for each cartridge. This will cause the next sequential cartridge to be automatically loaded into the drive. If this is a cleaning cartridge, a cleaning cycle will be executed and the cleaning cartridge will automatically be put back into the magazine. The next cartridge will then be automatically loaded into the drive to continue backup operation.
- Random Mode:
- Host sends the MOVE MEDIUM command to move the cleaning cartridge from the magazine to the drive.



# A

---

## Cassette Tape Drive and Autoloader Specifications

The following tables list the TLZ09 and TLZ10 cassette tape drive specifications.

**Table A-1 TLZ09/TLZ10 Cassette Tape Drive Specifications**

Characteristic	Specification(s)
Mode of operation	Streaming, and start/stop
Drive interface	Small Computer System Interconnect (SCSI-2)
Dimensions	See Table A-2
Supported Media (read/write)	DDS-1, 1.3 GB/ 2.6 GB, 4 mm x 60 m (TLZ04-CA) DDS-1, 2.0 GB/4.0 GB, 4 mm x 90 m (TLZ06-CA) DDS-2, 4.0 GB/8.0 GB, 4 mm x 120 m (TLZ07-CA) DDS-3, 12 GB/24 GB, 4 mm x 125 m (TLZ10-CA, TLZ10 only)
Bit density	114 Mbits per square inch (DDS-1) 171 Mbits per square inch (DDS-2) 341 Mbits per square inch (DDS-3) (TLZ10 only)
Transfer rate (typical)	778 Kbyte/s noncompression (DDS-2) (TLZ09) 1556 Kbyte/s compression (DDS-2) (TLZ09) 1.18 Mbyte/s noncompression (DDS-3) (TLZ10) 2.36 Mbyte/s compression (DDS-3) (TLZ10)
Recording format	Digital data storage (DDS-3 for TLZ10 only, DDS-2, DDS-DC, DDS-1)

## Cassette Tape Drive and Autoloader Specifications

**Table A-1 (Cont.) TLZ09/TLZ10 Cassette Tape Drive Specifications**

<b>Characteristic</b>	<b>Specification(s)</b>
Cassette capacity (typical)	4 Gbytes with 120 meter tape in native mode 8 Gbytes (typical) with 120 meter tape and data compression 12 Gbytes with 125 meter tape in native mode (TLZ10 only) 24 Gbytes (typical) with 125 meter tape and data compression (TLZ10 only)
Operating temperature <sup>1</sup>	5°C to 45°C (41°F to 113°F) for DDS-1 and DDS-2 15°C to 55°C (59°F to 131°F) for DDS-3
Nonoperating temperature	-40°C to 70°C (-40°F to 158°F)
Operating humidity <sup>1</sup>	20% to 80% RH maximum, noncondensing, maximum wet bulb temperature 26°C (79°F) for DDS-1 and DDS-2 10% to 80% RH maximum, noncondensing, maximum wet bulb temperature 26°C (79°F) for DDS-3
Nonoperating humidity	5% to 95% RH maximum, noncondensing
Operating altitude	0 to 4.6 km (0 to 15,000 ft)
Nonoperating altitude	0 to 4.9 km (0 to 16,000 ft) (TLZ09) 0 to 12.2 km (0 to 40,000 ft) (TLZ10)
Internal SCSI cable length (TLZ09/TLZ10 tabletop)	145 mm
Passes per cassette tape	2000
Power consumption (average)	
Tabletop	22 W
Drive	7.4 W
Power requirements (typical)	
Tabletop (TLZ09/TLZ10)	100 to 240 V ac, 0.3 A
3.5 Inch Drive	+5 V dc, 1.5 A (TLZ09), 1.0 A (TLZ10)
5.25 Inch Drive	+12 V dc, 0.2 A (TLZ09), 0.21 A (TLZ10)

<sup>1</sup> These values are media dependent.

## Cassette Tape Drive and Autoloader Specifications

**Table A-2 TLZ09/TLZ10 Cassette Tape Drive Dimensions**

<b>Dimensions</b>	<b>3.5 Inch Drive</b>	<b>5.25 Inch Drive</b>	<b>Tabletop</b>
Height	41.2 mm (1.6 in)	41.2 mm (1.6 in)	52.4 mm (2.07 in)
Width	101.6 mm (4.0 in)	146 mm (5.7 in)	160 mm (6.3 in)
Length	146 mm (5.7 in)	146 mm (5.7 in)	300 mm (11.8 in)
Weight	0.66 kg (1.5 lb) (TLZ09) 0.62 kg (1.4 lb) (TLZ10)	0.91 kg (2.0 lb) (TLZ09) 0.87 kg (1.9 lb) (TLZ10)	2.2 kg (4.85 lb)

**Table A-3 TLZ09/TLZ10 Tabletop Noise Declaration**

<b>Acoustics - declared values per ISO 9296 and ISO 7779:</b>		
	LwAd	LpAm (bystander positions)
Idle	4.8 B	39 dBA
Operating	4.9 B	40 dBA
<b>Schallemissionswerte - Werteangaben nach ISO 9296 und ISO 7779/DIN EN27779:</b>		
	LwAd	LpAm (Zuschauerpositionen)
Leerlauf	4,8 B	39 dBA
Betrieb	4,9 B	40 dBA)

**Note**

Current values for specific configurations are available from DIGITAL representatives. 1 B = 10 dBA.  
 Aktuelle Werte für spezielle Ausrüstungsstufen sind über die Digital Equipment Vertretungen erhältlich. 1 B = 10 dBA.

## Cassette Tape Drive and Autoloader Specifications

The following tables list the TLZ9L cassette tape autoloader specifications.

**Table A-4 TLZ9L Cassette Tape Autoloader Specifications**

<b>Characteristic</b>	<b>Specification(s)</b>
Mode of operation	Streaming, and start/stop
Drive interface	Small Computer System Interconnect (SCSI-2)
Dimensions	See Table A-5
Media (4 mm x 60 m)	TLZ04-CA cassette tape
Media (4 mm x 90 m)	TLZ06-CA cassette tape
Media (4 mm x 120 m)	TLZ07-CA cassette tape
Bit density	114 Mbits per square inch (DDS-1) 171 Mbits per square inch (DDS-2)
Transfer rate (typical)	778 Kbyte/s noncompression 1556 Kbyte/s compression
Recording format	Digital data storage (DDS-2, DDS-DC, DDS-1)
Cassette capacity (typical)	4 gigabytes with 120 meter tape in native mode 8 gigabytes (typical) with 120 meter tape and data compression
Magazine capacity	32 gigabytes with 120 meter tape in native mode 64 gigabytes (typical) with 120 meter tape and data compression
Operating temperature	10°C to 45°C (50°F to 113°F)
Nonoperating temperature	-40°C to 70°C (-40°F to 158°F)
Operating humidity	20% to 80% RH maximum, noncondensing, maximum wet bulb temperature 26°C (79°F)
Nonoperating humidity	5% to 95% RH maximum, noncondensing
Operating altitude	0 to 4.6 km (0 to 15,000 ft)
Nonoperating altitude	0 to 4.9 km (0 to 16,000 ft)
Internal SCSI cable length (TLZ9L-DA/DB)	145 mm
Passes per cassette tape	2000

## Cassette Tape Drive and Autoloader Specifications

**Table A-4 (Cont.) TLZ9L Cassette Tape Autoloader Specifications**

Characteristic	Specification(s)
Power consumption (typical, write mode)	
Tabletop	30 W
Embedded	8.4 W
Power requirements (typical)	
Tabletop (TLZ9L-DA/DB)	100 V ac, 0.3 A 240 V ac, 0.14 A
Embedded (TLZ9L-AA)	+5 V dc, 1.2 A
Embedded (TLZ9L-AA)	+12 V dc, 0.2 A

**Table A-5 TLZ9L Cassette Tape Autoloader Dimensions**

Dimensions	TLZ9L-AA	TLZ9L-DA/DB
Height	82.5 mm (3.25 in)	109 mm (4.29 in)
Width	146.0 mm (5.75 in)	211 mm (8.31 in)
Length	241.6 mm (9.51 in)	296 mm (11.65 in)
Weight	2.4 kg (5.30 lb)	5.0 kg (11.0 lb)

## Cassette Tape Drive and Autoloader Specifications

**Table A-6 TLZ9L-DA/DB Noise Declaration**

<b>Acoustics - declared values per ISO 9296 and ISO 7779:</b>		
	LwAd	LpAm (bystander positions)
Idle	4.7 B	33 dBA
Operating	4.8 B	34 dBA
<b>Schallemissionswerte - Werteangaben nach ISO 9296 und ISO 7779/DIN EN27779:</b>		
	LwAd	LpAm (Zuschauerpositionen)
Leerlauf	4,7 B	33 dBA
Betrieb	4,8 B	34 dBA)

**Note**

Current values for specific configurations are available from DIGITAL representatives. 1 B = 10 dBA.  
Aktuelle Werte für spezielle Ausrüstungsstufen sind über die Digital Equipment Vertretungen erhältlich. 1 B = 10 dBA.

---

## Product Notes for DIGITAL UNIX, OpenVMS, and Windows NT

### DIGITAL UNIX TLZ09/TLZ10 Compression and Noncompression Modes

The default mode for the TLZ09/TLZ10 tape drives is for compression enabled. For software control of compression, use the following commands. To use the drive in compression mode, specify the device as:

```
/dev/rmt?h or /dev/rmt?m
```

To use the drive in noncompression mode, specify the device as:

```
/dev/rmt?1 or /dev/rmt?a
```

### DIGITAL UNIX DUMP Utility

It should be noted that the numbers returned by the DUMP utility are not accurate. However, use of the following parameters will ensure proper operation.

The parameters that should be used when running the DUMP utility on a DDS-2 tape in compressed and noncompressed mode are as follows:

Noncompressed Mode:

density = 61000 effective tape length (with 120 meter tape)

size = 76586 (with 120 meter tape)

Example: dump 0dsf 61000 76586 /dev/rmt?1 /dev/rrz0g

## Product Notes for DIGITAL UNIX, OpenVMS, and Windows NT

### Compressed Mode:

density = 61000 effective tape length (with 120 meter tape)  
size = 76586 (with 120 meter tape) × compression (which, for most cases is 2)  
Example: dump 0dsf 61000 153172 /dev/rmt?h /dev/rrz0g

---

#### Note

---

You must type UNIX commands using lowercase characters. For DDS-3 (125 meter tape), the size field should be multiplied by 3 in each of the previous cases (TLZ10 only).

---

## OpenVMS TLZ09/TLZ10 Compression and Noncompression Modes

The default mode for the TLZ09/TLZ10 tape drive is for compression mode. For software control of compression, use the following commands. To use the drive in compression mode, specify:

```
MEDIA_FORMAT=COMPACT software switch
```

To use the drive in noncompression mode, specify:

```
MEDIA_FORMAT=NOCOMPACT software switch
```

Examples for enabling/disabling compression are:

```
INIT/MEDIA_FORMAT=(NO)COMPACT MKx# :  
MOUNT/MEDIA_FORMAT=(NO)COMPACT MKx# :  
BACKUP/MEDIA_FORMAT=(NO)COMPACT MKx# :
```

---

#### Note

---

To be sure that the compression is enabled/disabled, you should include the correct software switch with each command line.

---

## Windows NT TLZ09/TLZ10 Compression and Noncompression Modes

Compression mode is enabled/disabled via drive configuration setup in Windows NT. See your Windows NT documentation for more details.



## DIGITAL Operating System Support

Table B-1 lists the minimum operating system version for full support for the TLZ09/TLZ10 tape drives and the TLZ9L cassette tape autoloader.

**Table B-1 Operating System Support**

Device	Minimum Operating System Version for Full Support		
	DIGITAL UNIX	OpenVMS	Windows NT
TLZ09	V3.2	V6.1-1H2	V3.51, V4.0 ServicePack5
TLZ9L	V3.2G	V6.2-1H3	V4.0 ServicePack2
TLZ10	V4.0A <sup>1</sup>	V6.2-1H3	V4.0 with DIGITAL supplied Windows NT driver kit (PN QZ- 012AA-UC)

<sup>1</sup> V3.2G and V4.0 provide full support with available patch kits.



---

## Product Notes for Non-DIGITAL Platforms

---

### Note

---

Check DIGITAL's storage web page for up-to-date information about support for non-DIGITAL platforms at: <http://www.storage.digital.com>

---

## Product Notes for Novell NetWare and Microsoft Windows NT

This section provides information for the system administrator who should read this material before installing and using the TLZ09/TLZ10 DAT tape drives or TLZ9L autoloader with a host system operating under the Novell NetWare or Microsoft Windows NT operating systems.

### Host SCSI Interface

The tape drive uses the standard SCSI-2 command set to interface to the PC-based host system. The host system thus must be equipped with a SCSI adapter to properly interface the tape drive with the host. For example, the host SCSI adapter might interface the computer's PCI bus to the SCSI-2 port of the tape drive.

A host PC SCSI adapter is normally supplied with a compatible software driver for use with its operating system. When operating under the Novell NetWare or the Microsoft Windows NT operating systems, the software driver must be pre-loaded in accordance with the SCSI adapter manufacturer's installation procedure to ensure a proper interface between the tape drive and the host. In addition, a user-level tape read/write software program may be required to implement tape support under the NetWare or Windows NT environments. There are many commercial software products available that provide for host or network-based data backup and restore, archiving, data logging, etc. for these operating systems.

## Product Notes for Non-DIGITAL Platforms

Before purchasing a user-level software product, ensure that the tape drive or tape loader is supported by that product. Commercial software vendors usually publish a supported hardware list, or have telephone technical support personnel who will answer questions regarding compatibility of a particular tape drive or other storage devices. When choosing a software product suitable for your application, follow the software vendor's installation procedure to implement support for your tape drive.

The TLZ09 is supported only under Windows NT version 3.51 by adding the "4 millimeter Sony drive" tape device option. Follow the Windows NT "Add/Remove Tape Devices" procedure to add this support. The TLZ10 is not supported under Windows NT version 3.51.

The TLZ09 is supported only under Windows NT version 4.0 by adding the "4 millimeter DAT drive" tape device option. Follow the Windows NT "Tape Devices" procedure to add this support. The TLZ10 is supported only under Windows NT version 4.0 by adding the "4 millimeter Sony drive" tape device option. Follow the Windows NT "Add/Remove Tape Devices" procedure to add this support.

The Novell NetWare operating system provides tape backup software called SBACKUP which will work with the product. Refer to the NetWare documentation for instructions on configuring this product and operating the SBACKUP utility.

---

### Notes

---

SBACKUP does not support autoloaders. You will need to use a commercially available backup software package for the TLZ9L autoloader.

Please check the Novell web page for TLZ10 support information.

---

Native tape support (that is, the tape support supplied in the operating system) for Windows NT or NetWare will support the functions of a single drive. Limited tape loader support (manual or sequential mode) is also provided as native support.

## Product Notes for Sun

This section describes how to include the TLZ09 tape drive or TLZ9L autoloader in a Sun SPARC system running Solaris™ 2.3 (or later) or SunOS™ 4.1.x. The information covers configuration of the host system to communicate with the tape drive.

### General Information

---

#### Note

---

This tape drive supports a variable block size and a small number of fixed block sizes. Maximum performance is obtained by using the variable block size mode whenever possible. Selecting this mode is based on two variables in the configuration file (st\_conf.c and st.conf) - "block size", which should be set to 0, and the "ST\_VARIABLE" switch which must be OR'd with the other switches. Depending on your version of the Solaris operating system, you may not be able to use the variable block size mode.

If your operating system version is:

- SunOS 4.1.x or Solaris 2.3, set the block size in the tape configuration file to 8192.
- Solaris 2.4 or 2.5, set the block size in the tape configuration file to 0.

These recommendations are for use with system utilities. For third party software, follow the recommendations of the manufacturer. Use the following steps to implement this information.

---

You must rebuild your kernel, with the parameters given, to ensure that your device functions properly.

When using the **dump** utility under SunOS 4.1.x, you must supply the correct "d bpi" (density code) and "s size" tape length for **dump** to calculate the correct number of tapes required. The "b factor" (blocking factor) is of less importance, and we recommend a value of 128 for that parameter.

Compression can be enabled/disabled at any time by selecting the appropriate device file. See the following sections on "st\_conf.c" and "st.conf" for details on how we configure density codes.

## Product Notes for Non-DIGITAL Platforms

In general, the density code hex value **0xfd** turns off compression and the code **0xfe** turns it on. Since four driver variations are created, a number of combinations are possible. We configured our systems for two drivers without compression and two drivers with compression; you may decide that some other combination is more suitable for your system.

## Modifications Required for SunOS 4.1.x

### Installation Procedure

---

#### Note

---

In order to support the addition of this device, your system's `/sys/scsi/targets/st_conf.c` file must contain the applicable drive information. For additional information on this requirement, read the **man** pages for "st".

---

### System Modification

Perform the following steps to modify the system for communication with the TLZ9L autoloader (see notes at the end of this sub-section for TLZ09 differences):

1. From the command line, type:

```
cd /sys/scsi/targets
```

2. Edit the "st\_conf.c" file and carefully add the following structure before the "/\* TLZ9 4mm 8GB \*/" entry:

```
/* Entry for DEC TLZ9L. DAT 4mm Helical Scan tape drive, /w
Compression. */
{
    "DEC 8GB 4mm Helical Scan", 12, "DEC^^^^^TLZ9",
    ST_TYPE_DEFAULT, 8192,
    (ST_VARIABLE <VBAR> ST_BSF <VBAR> ST_BSR <VBAR>
    ST_LONG_ERASE <VBAR> ST_KNOWS_EOD),
    5000, 5000,
    { 0xfd, 0xfd, 0xfe, 0xfe },
    { 0, 0, 0, 0 }
},
```

## Product Notes for Non-DIGITAL Platforms

3. Verify that the above entry is added to the `st_conf.c` file correctly.

Where,

- The first parameter (`DEC 8GB 4mm Helical Scan`) is the name given to the drive.
- The second parameter (`12`) is the length of the vendor ID provided by the "inquiry" command.
- The third parameter (`DEC^^^^^TLZ9`) is the vendor ID. (Ensure that five spaces, represented by the ^, are included between "DEC" and "TLZ9" elements.)
- The fourth parameter (`ST_TYPE_DEFAULT`) is the drive type for the driver.
- The fifth parameter (`8192`) is a block size in bytes.
- The sixth parameter (`ST_VARIABLE <VBAR> ST_BSF <VBAR> ST_BSR <VBAR> ST_LONG_ERASE <VBAR> ST_KNOWS_EOD`) comprises the drive options.
- The seventh parameter (`5000`) is the maximum number of read retries.
- The eighth parameter (`5000`) is the maximum number of write retries.
- The ninth parameter (`0xfd, 0xfd, 0xfe, 0xfe`) comprises the density codes (low \_ hi) as defined below:
  - `0xfd` is the vendor-unique density code for the 120-m DDS2 tape in the uncompressed mode (4.0 GB).
  - `0xfe` is the vendor-unique density code for the 120-m DDS2 tape in the compressed mode (8.0 GB, assuming a 2:1 compression ratio).
- The tenth parameter (`0, 0, 0, 0`) is the speed code (not used).

For the TLZ09 tape drive, perform the same steps as for the TLZ9L, with the following exceptions:

In step 2, instead of

```
"DEC 8GB 4mm Helical Scan", 12, "DEC^^^^^TLZ9",
```

Substitute:

```
"DEC 8GB 4mm Helical Scan", 13, "DEC^^^^^TLZ09", for the TLZ09
```

### Rebuilding of Kernel

After you have edited the "`st_conf.c`" file and added the above entry, rebuild the kernel using the standard procedure (for further help, refer to the man pages of the `config` command).

## Product Notes for Non-DIGITAL Platforms

### Installation of Tape Drive

Install the tape drive into the storage subsystem and power on the workstation. We recommend that the tape drive's SCSI device address be set to ID 4 or to ID 5.

---

#### Note

---

If your SCSI host adapter is supported by the "probe-scsi" command, you can use this command at the boot prompt to verify that the connected device is correctly attached to the system.

---

### Rebooting of System

Reboot the system, using the following command at the boot prompt:

```
>boot
```

The system reboots with the newly compiled kernel and creates special files in **/dev** so that it can communicate with the tape drive. Verify that "DEC 8GB 4mm Helical Scan" is displayed for the TLZ09 or TLZ9L as a target when the system is booting.

At this time the tape is configured in the **/dev** directory with "**rst**" (rewind on close) and "**nrst**" (no rewind on close) format. If the entry in the kernel configuration file for the tape drive were **st0**, for example, then "**rst**" would be "**rst0, rst8, rst16, rst24**" and "**nrst**" would be "**nrst0, nrst8, nrst16, nrst24**".

- **rst0** and **nrst0** correspond to the **0xfd** density mode (120-m DDS2 tape, uncompressed format).
- **rst8** and **nrst8** correspond to the **0xfd** density mode (120-m DDS2 tape, uncompressed format).
- **rst16** and **nrst16** correspond to the **0xfe** density mode (120-m DDS2 tape, compressed format).
- **rst24** and **nrst24** correspond to the **0xfe** density mode (120-m DDS2 tape, compressed format).



## Product Notes for Non-DIGITAL Platforms

### Testing the Tape Drive

To test the tape drive, back up the "**passwd**" file to tape using the "**tar**" command, as follows:

```
tar cvf /dev/rst0 /etc/passwd
```

The system responds with something similar to the following:

```
a /etc/passwd 1 blocks
```

Note that depending on the size of the file, a different number of blocks may be reported.

### Verification

Verify that the "**passwd**" file was written to tape using the following command:

```
tar tvf /dev/rst0
```

The system responds with something similar to the following:

```
rw-r--r-- 0/10 535 Mar 23 16:31 1994 /etc/passwd
```

The installation and verification procedure is now complete.

### Dump Parameters for the Tape Drive

The parameters that should be used when running the dump utility with the tape drive are:

```
density = 61000 (for DDS1 or DDS2 tapes)
size    = one of the following, as appropriate:
          6656 (for 60 meter tapes)
          10240 (for 90 meter tapes)
          20480 (for 120 meter tapes)
          61440 (for 125 meter tapes)
blocking factor = 128
```

### Example

The following example shows the command for backing up an entire disk partition onto the tape drive, using a 120-meter tape:

```
dump 0dsbf 61000 20480 128 /dev/rst0 /dev/sd0g
```

For further help, refer to **man** pages of the **dump** command.

## Modifications Required for Solaris 2.3 (or later)

### Installation Procedure

---

#### Note

---

In order to support the addition of this device, drive information must be supplied in the `/kernel/drv/st.conf` file as global properties that apply to each of the targets, or as properties that are applicable to one target only. The "st driver" looks for the property called "tape-config-list". For additional information, read the **man** page "st". We recommend here the use of the global properties approach.

---

### System Modification

Perform the following steps to modify the system to communicate with the autoloader (see notes at the end of this sub-section for TLZ09 differences):

1. From the command line, type:

```
cd /kernel/drv
```

2. Edit the "**st.conf**" file by adding the following before the first occurrence of "name=":

```
# entry for TLZ9L tape drive
tape-config-list = "DEC^^^^^TLZ9",
" DEC 8GB 4mm Helical Scan", "TLZ9-data";
TLZ9-data = 1,0x34,0,0x1639,4,0xfd,0xfd,0xfe,0xfe,3;
```

Where:

In the "**tape-config-list**" parameter:

- The first parameter (`DEC^^^^^TLZ9`) is the parameter returned by the tape drive on a SCSI inquiry command. (There should be five spaces between the "DEC" and "TLZ9" elements.)
- The second parameter (`DEC 8GB 4mm Helical Scan`) is a *nickname* for the tape drive.

## Product Notes for Non-DIGITAL Platforms

- The third parameter is defined as follows:

In the "TLZ9-data" string:

- The first parameter (1) is the revision level of the software and is set to 1.
- The second parameter (0x34) is the tape type, specifying "other" tape drive. (This is defined in /usr/include/sys/mtio.h.)
- The third parameter (0) is the block size in bytes (see note at beginning of this section).
- The fourth parameter (0x1639) defines the options selected. The 0x1639 value represents the following options:

```
ST_VARIABLE      = 0x0001
ST_BSF           = 0x0008
ST_BSR           = 0x0010
ST_LONG_ERASE    = 0x0020
ST_KNOWS_EOD     = 0x0200
ST_UNLOADABLE   = 0x0400
ST_LONG_TIMEOUTS = 0x1000
```

- The fifth parameter (4) defines the number of densities. The maximum definable number of densities is 4<sup>1</sup>.
- The sixth through ninth parameters (0xfd, 0xfd, 0xfe, 0xfe) comprise the density codes (low \_ hi) as defined below:
  - 0xfd is the vendor-unique density code for the 120-m DDS2 tape in the *uncompressed* mode (4.0 GB).
  - 0xfe is the vendor-unique density code for the 120-m DDS2 tape in the *compressed* mode (8.0 GB).
- The last parameter in the data string is the default density of 3 for the 120-m DDS2 tape in the compressed mode.

---

<sup>1</sup> This maximum definable number of densities is a Sun Operating System limitation.

## Product Notes for Non-DIGITAL Platforms

For the TLZ09 tape drives, perform the same steps as for the TLZ9L with the following exceptions:

In step 2, instead of

```
"tape-config-list = "DEC^^^^^TLZ9",
```

Substitute:

```
"tape-config-list = "DEC^^^^^TLZ09", for the TLZ09
```

### System Shutdown

After you have edited the "**st.conf**" file, shut down the system as follows:

```
sync  
cd /  
shutdown -i0 -g0 -y
```

### Installation of the Tape Drive

Install the tape drive into the storage subsystem and power on the workstation. We recommend that the tape drive's SCSI device address be set to ID 4 or to ID 5.

---

#### Note

---

If your SCSI host adapter is supported by the "probe-scsi" command, then you can use this command at the boot prompt to verify that the connected device is correctly attached to the system.

---

## Product Notes for Non-DIGITAL Platforms

### Rebooting of System

Reboot the system using the following command at the boot prompt:

```
>boot -rv
```

Note that the switch "**r**" forces the kernel to be re-configured, and switch "**v**" enables a display of the system configuration at boot time.

The system compiles the kernel and creates special files in **/dev** so that it can communicate with the tape drive. Since you booted the system using the verbose switch, the system displays all of its SCSI targets. Verify that "DEC 8GB 4mm Helical Scan" is displayed for the TLZ09 or TLZ9L as a target when the system is booting.

At this time, the tape drive is configured in the **/dev** directory in two ways: **rmt** format, and **rst** format.

#### "rmt" format

In this format, the drive is configured with various options. For further explanations, see the man pages on "**st**" (the modes are **x**, **xl**, **xm**, **xh**, **xc**, and **xu**, where **x** is the **rmt** number).

- Options **x**, **xh**, **xu**, and **xc** correspond to the **0xfe** density mode (120-m DDS2 tape, *compressed* format).
- Options **xl** and **xm** correspond to the **0xfd** density mode (120-m DDS2 tape, *uncompressed* format).
- Option **b** associates with the BSD behavior and is for backward compatibility on all of the above options. For further information, refer to the man pages of "**mtio**".

The **n** option provides access to the device with **no rewind**, similar to **nrst** (below), and is also applicable to all of the above options.

#### "rst" format

Special files "**rst**" (rewind on close) and "**nrst**" (no rewind on close) are also built and reside in the **/dev** directory. For example, if the SCSI target ID for the tape drive is 4 and the drive is connected to the native SCSI bus, then "**rst**" will be "**rst4**, **rst12**, **rst20**, and **rst28**" and "**nrst**" will be "**nrst4**, **nrst12**, **nrst20**, and **nrst28**".

- **rst4** and **nrst4** correspond to the **0xfd** density mode (120-m DDS2 tape, *uncompressed* format)
- **rst12** and **nrst12** correspond to the **0xfd** density mode (120-m DDS2 tape, *uncompressed* format)

## Product Notes for Non-DIGITAL Platforms

- **rst20** and **nrst20** correspond to the **0xfe** density mode (120-m DDS2 tape, *compressed* format)
- **rst28** and **nrst28** correspond to the **0xfe** density mode (120-m DDS2 tape, *compressed* format)

### Test

To test the tape drive, back up the "**passwd**" file to tape using the "**tar**" command, as follows:

```
tar cvf /dev/rst4 /etc/passwd
```

The system responds with:

```
a /etc/passwd 1 blocks
```

Note that, depending on the size of the file, a different number of blocks may be reported.

### Verification

Verify that the "**passwd**" file was saved to tape using the following command:

```
tar tvf /dev/rst4
```

The system responds with:

```
rw-r--r-- 0/10 535 Mar 23 16:31 1994 /etc/passwd
```

The installation and verification procedure is now complete.

### Dump Parameters for the Tape Drive

The parameters that should be used when running the **ufsdump** utility with the tape drive are as follows:

```
density (d) = 61000 (BPI)  
blocking factor = 128
```

#### Example

The following parameter is an example of the command for backing up an entire disk partition (`/dev/rdisk/c0t3d0s6`) onto the tape drive:

```
ufsdump 0dbfo 61000 128 /dev/rmt/2 /dev/rdisk/c0t3d0s6
```

## Product Notes for IBM RS/6000

This section provides information for the system administrator. It should be read before installing and using the TLZ09 tape drive or TLZ9L autoloader with a host system with the AIX 3.2.5 (or later) operating system. The TLZ10 is not supported on IBM systems.

### Modifications Required to Operate the Tape Drive with AIX 3.2.5 (or later)

After the TLZ09 tape drive or TLZ9L autoloader has been properly attached to the SCSI bus, install the device using "smit" or by executing specific commands while logged into the root account. The Section "Installing the Tape Drive Using the SMIT Command" describes how to install the tape drive using the fast-path command (`smit dev`). The Section "Installing the Tape Drive Using Command-Line Interface" describes how to install the device using the command-line interface.

#### Installing the Tape Drive Using the SMIT Command

1. From the command line, type:  

```
# smit dev
```
2. Select menu entry "Configure the devices you have added after the IPL."
3. Select menu entry "Tape Drive."
4. Select menu entry "Change/show the characteristics."
  - a. Select the entry that matches the controller and target ID of your installation.  
Example: `rmt1 available 00-03-00-50 other SCSI tape drive`  
where 3 is the SCSI controller number and 5 is the SCSI target ID
  - b. On the menu, change the settings of the "BLOCK size", "DENSITY setting #1", and "DENSITY setting #2":  

```
Set "BLOCK size" to 0.  
Set "DENSITY setting # 1" to 254.  
Set "DENSITY setting #2" to 253.
```
  - c. Accept the changes.

## Product Notes for Non-DIGITAL Platforms

### Installing the Tape Drive Using Command-Line Interface

1. From the command line, type:

```
# cfgmgr
```

2. To determine which rmt has been added, type:

```
# lsdev -Cc tape
```

Example:

```
# lsdev -Cc tape
Name      Status      Location      Description
rmt0      Available   00-03-00-50   Other SCSI Tape Drive
```

3. Next, type:

```
# chdev -l <rmt*> -a density_set_1=254 -a density_set_2=253
```

4. Finally, type the following:

```
# chdev -l <rmt*> -a block_size=<SIZE> -a rwtimeout=<SEC>
```

Example:

```
# chdev -l rmt0 -a block_size=0 -a rwtimeout=300
rmt0 changed
```

where,

<rmt\*> is the tape drive added as shown by the lsdev command.

<SIZE> is the fixed block size (0 = variable, 0 is suggested).

<SEC> is timeout in seconds, (300 seconds recommended).

---

Density Code	Description
0 (00h)	Default density.
19 (13h)	DDS-1 format.
36 (24h)	DDS-2 format.
127 (7Fh)	Use current density.
253 (FDh)	Current density with data compression disabled.
254 (FEh)	Current density with data compression enabled.

---



## Product Notes for Non-DIGITAL Platforms

The files that are created are:

---

Tape Drive Special File Characteristics			
Special File Name	Rewind-on-Close	Retention-on-Open	Bytes-per-Inch
/dev/rmt*	Yes	No	Density Setting # 1
/dev/rmt*.1	No	No	Density Setting # 1
/dev/rmt*.2	Yes	Yes	Density Setting # 1
/dev/rmt*.3	No	Yes	Density Setting # 1
/dev/rmt*.4	Yes	No	Density Setting # 2
/dev/rmt*.5	No	No	Density Setting # 2
/dev/rmt*.6	Yes	Yes	Density Setting # 2
/dev/rmt*.7	No	Yes	Density Setting # 2

---

---

### Note

---

IBM-supplied tape drives default to a block size of 0 while tape drives from other manufacturers default to a block size of 512. DIGITAL recommends changing the block size of the TLZ09 or TLZ9L to 0 (variable size) to increase performance.

---

## Using the Tape Drive to Install AIX

1. Perform the installation procedure as described in *AIX, version 3.2, Installation Guide* (SC23-2341), Chapter 1, ending after completing step F.5.c of the procedure.
2. If the tape device is displayed as "defined" instead of "available", then enter the following:

```
# mkdev -l <LITERAL>(<rmt*>)
```

Example:

```
# mkdev -l rmt0
rmt0 Available
```

Continue with step F.5.d in the *AIX Installation Guide* until the installation is completed.

## Product Notes for Hewlett-Packard

This section describes how to include the TLZ09 tape drive or TLZ9L autoloader in an HP 9000 Series 700 system running HP-UX 9.05, 10.01, or 10.10 and Series 800 system running HP-UX 10.10. The information covers configuration of the host system to communicate with the tape drive.

### General Information

#### Tape Drivers:

If the necessary drivers are not already built into your existing kernel, you will need to rebuild your kernel. To determine which drivers are currently installed, issue the `lsdev` command.

The following drivers are used by the accompanying operating system:

OS Version	Driver
9.05	scsitape
10.01, 10.10	stape

#### Note

The S800 tape2 driver is not supported. The stape driver is generally only available on newer model S800 computers.

When using the **dump** utility, you must supply the correct density code and tape length size for **dump** to use in its calculations. Refer to the Section “Dump Parameters for the Tape Drive” for details.

Compression can be enabled/disabled at any time by selecting the appropriate device file name. See the Section “System Device Files” for device names.

### Modifications Required

#### Operating System Patches:

The following software patches should be applied for proper operation of the tape drive. All of the patches may be obtained directly from Hewlett-Packard. For OS Release 9.05, install patches PHCO\_2983 and PHCO\_6738. For OS Release 10.01, install patch PHCO\_7272. For OS release 10.10, install patch PHCO\_7271, PHKL\_7853 and PHKL\_8360.

## Product Notes for Non-DIGITAL Platforms

### Installation Procedure

---

#### Note

---

The "DEC TLZ09" or "DEC TLZ9" designation returned in response to SCSI inquiry during performance of the following procedure is the internal name for the tape drive, as incorporated in and used by the firmware.

---

### Installation of Tape Drive

Install the tape drive into the StorageWorks enclosure and power-on the workstation. Ensure that the address of the tape drive does not conflict with the address of any other device on that SCSI bus.

Issue the `ioscan -f` command to determine if the kernel attached to the tape driver to the device on boot. If UNKNOWN or UNCLAIMED is displayed in the class column, proceed to the Section "System Modification." If the driver is attached, skip that section.

### System Modification

Enter the System Administration Manager (SAM) as superuser. From the first-level menu, choose **Peripheral Devices**. From the second-level menu, choose **Tape Drives**. The system's hardware will be scanned, and the "available tape drives" window will identify the tape drive as a SCSI tape drive (HP-UX 9.05), or as a DEC TLZ9 or DEC TLZ09 (HP-UX 10.x) with the appropriate hardware path. Highlight that selection and then pull down the **Actions** menu and select the **Add** function. The program at this time will check the kernel to determine if the necessary drivers are built in, displaying the results.

If necessary, the program will rebuild the kernel. If this occurs, you will have to reboot the system in order to use the tape drive.

For further information on adding tape devices, refer to Hewlett-Packard's *Installing Peripherals* manual (P/N B2355-40041) and to *Configuring HP-UX for Peripherals* manual (P/N B2355-90053).

### System Device Files

The System Administration Manager program automatically creates the appropriate special device files and places them in the `/dev/rmt` directory when adding the device through SAM. Additionally, if the appropriate drivers are built into the kernel, the device files will be created automatically upon system initialization.

## Product Notes for Non-DIGITAL Platforms

### HP-UX 9.05

The following naming convention is used for the DDS-format tape drive, as shown in the examples listed below:

```
/dev/rmt/c#d#[hlmc][n][b]
```

Where:

- c# specifies the controller designation, which may contain either two or three characters, specifies the following:  
where # is sc[f], in accordance with the following:
- s is the system bus module:
    - 2 = core I/O (the default)
    - 4 = EISA SCSI
  - c is the slot number:
    - 0 for core I/O
    - n for EISA, the value is determined by the slot number as reported by the H/W path reported by "ioscan".
  - f is the function number. This value identifies the location on the core I/O bus. For the SCSI interface, the value is 1. If you are using the EISA SCSI interface, the value is 0.
- d# designates the SCSI address of the tape drive, where # here identifies a number value.
- h/l/m/c specifies density, with h meaning high density, l meaning low density, m meaning standard DDS format, and c meaning data compression<sup>2</sup>
- n specifies no rewind on close.
- b specifies Berkeley behavior.

For additional information about DDS tapes, refer to **mt(7)** of the *HP-UX Reference manual* (P/N B 2355-90033) or the *man* pages.

---

<sup>2</sup> The h, l, and m device designations all yield the same results. The c device designation enables compression.

## Product Notes for Non-DIGITAL Platforms

### Examples:

For a tape drive installed in slot location 4 of the Digital StorageWorks SWXSE-02 expansion enclosure connected to the main (core) SCSI bus, the following device files would be produced in the directory **/dev/rmt**:

c201d4c	c201d4l	c201d4cb	c201d4lb
c201d4cn	c201d4ln	c201d4cnb	c201d4lnb
c201d4h	c201d4m	c201d4hb	c201d4mb
c201d4hn	c201d4mn	c201d4hnb	c201d4mnb

For a tape drive installed in slot location 4 of the digital StorageWorks SWXSE-02 expansion enclosure connected to a SCSI adapter in EISA slot 1, the following device files would be produced in the directory **/dev/rmt**:

c410d4c	c410d4l	c410d4cb	c410d4lb
c410d4cn	c410d4ln	c410d4cnb	c410d4lnb
c410d4h	c410d4m	c410d4hb	c410d4mb
c410d4hn	c410d4mn	c410d4hnb	c410d4mnb

### HP-UX 10.x

The following naming convention is used on systems which support long filenames for the DAT format tape drive as shown in the examples below:

```
/dev/rmt/c#t#d#BEST[n][b]
```

#### Where:

c#	specifies the instance number of the interface card
t#	specifies the SCSI address of the tape drive
d#	specifies the device unit number (LUN) at the SCSI address
BEST	specifies the highest capacity density, which for this device is the compressed format (8 GB)
n	specifies no rewind on close
b	specifies Berkeley behavior

## Product Notes for Non-DIGITAL Platforms

### Examples:

For the tape drive, set to SCSI address 4 connected to the main (core) SCSI bus, the following device files would be produced in the directory `/dev/rmt`:

```
c0t4d0BEST          c0t4d0BESTnb
c0t4d0BESTb        c0t4d0BESTnb
```

For systems which do not support long filenames, the following device naming convention is used:

```
#m      #mb      #mn      #mnb
```

### Where:

- # specifies an arbitrary number to distinguish this tape drive from others.
- n specifies no rewind on close
- b specifies Berkeley behavior

To list the device files associated with each device, issue the command:

```
ioscan -f -n|more
```

## Testing the Tape Drive

To test the tape drive, back up the "passwd" file to tape using the "tar" command as follows (assuming that you installed the drive in accordance with the first preceding example):

```
tar cvf /dev/rmt/c201d4h /etc/passwd
```

The system responds with something similar to the following:

```
a /etc/passwd 1 blocks
```

Note that depending on the size of the file, a different number of blocks may be reported.

## Verification

Use the following command to verify that the "passwd" file was written to tape:

```
tar tvf /dev/rmt/c201d4h
```

The system responds with something similar to the following:

```
rw-r--r-- 0/10 535 Mar 23 16:31 1994 /etc/passwd
```

The installation and verification procedure is now complete.

## Product Notes for Non-DIGITAL Platforms

### Dump Parameters for the Tape Drive

The parameters that should be used when running the dump utility with the tape drive are:

```
density = 61000 (for DDS1 or DDS2 tapes)
```

```
size = one of the following, as appropriate:
```

```
6656 (for 60 meter tapes)
```

```
10240 (for 90 meter tapes)
```

```
20480 (for 120 meter tapes)
```

```
blocking factor = 128
```

#### Example:

The following example shows the command for backing up an entire disk partition onto the tape drive using a 120-meter tape (use the correct filename for the operating system in use):

```
dump 0dsbf 61000 20480 128 /dev/rmt/c201d4h /usr
```

For further help, refer to *man* pages of the **dump** command.





---

# Index

## B

---

Busy LED, 5-2

## C

---

Cartridge number indicators, 7-10

Cassette magazine  
setting the write-protect tab, 7-8

Cassette tape  
handling of, 5-5  
setting the write-protect tab, 5-6

Checking your shipment for Model  
TLZ9L-DA/DB, 1-8

Checking your shipment for tabletop  
drives, 1-8

Cleaning requirements, 7-19

## D

---

Design features, 1-2

Diagnostics  
console-based or self-tests, 6-4

Digital audio tape (DAT), 1-2

Digital data storage (DDS), 1-2

DIGITAL service, 6-4

## E

---

Enabling/Disabling Data Compression,  
B-1

Error indicator, 7-9

## H

---

Head cleaning, 6-1

Head cleaning cassette, 6-2

## I

---

Inserting a cassette tape into the drive,  
5-7

Installing

DS-TLZ10-DB tabletop drive, 2-1

TLZ09-AA/AB cassette tape  
drive, 3-1

TLZ09-BA/BB cassette tape drive,  
3-1

TLZ09-DA/DB tabletop drive, 2-1

TLZ10-AB cassette tape drive, 3-  
1

TLZ10-BB cassette tape drive, 3-  
1

TLZ9L-DA/DB tabletop  
autoloader, 2-1

## L

---

LCD panel, 7-6

LED indicators, 7-2

## M

---

Media Recognition System (MRS), 1-3

## Index

### O

---

Ordering additional cassettes, 1–9

### P

---

Power cable, 2–4, 3–6

Power switch, 5–1

Power-on self-test, 4–1

Preventive maintenance, 6–1

Problem solving, 6–3

Product description, 1–1

### S

---

SCSI signal cable

device to device, 2–4

device to system, 2–3

drive to system, 3–6

Status LED, 5–2

System support, 1–2

### T

---

Tape LED, 5–2

TLZ09 cassette tape drive

busy LED, 5–2

indicators, 5–6

installation verification, 4–1

location of buttons, switches,  
connectors, 2–2

power switch, 5–1

specifications, A–1

status LED, 5–2

tape LED, 5–2

unload button, 5–1

using, 5–1

TLZ09 models, 1–3

TLZ10 cassette tape drive

busy LED, 5–2

indicators, 5–6

installation verification, 4–1

location of buttons, switches,  
connectors, 2–2

power switch, 5–1

specifications, A–1

status LED, 5–2

tape LED, 5–2

unload button, 5–1

using, 5–1

TLZ10 models, 1–3

TLZ9L cassette tape autoloader

7-segment display, 7–9

autoload function, 7–18

automatic operations, 7–10

cartridge number indicators, 7–10

eight cartridge mode, 7–11

ejecting magazine, 7–16

error indicator, 7–9

LCD panel, 7–6

LED indicators, 7–2

loading cartridges into magazine,  
7–14

loading magazine, 7–15

location of buttons, switches,

connectors, 2–2

magazine operations, 7–11

manual operations, 7–11

operation, 7–10

SCSI ID select switch, 7–19

seven cartridge mode, 7–12

single cartridge mode, 7–13

specifications, A–4

switch settings, 7–18

switchpack settings, 7–18

unloading cartridges from  
magazine, 7–17

using, 7–1

warning indicator, 7–7

write-protect indicator, 7–8

TLZ9L models, 1–4

### U

---

Unload button, 5–1

### W

---

Warning indicator, 7–7

Write-protect indicator, 7–8

Write-protect tab, 5–6, 7–8